

SECTION 3. PARTS INFORMATION

3-1. INTRODUCTION

This section lists the replaceable parts of the Henny Penny Model 291 fryer.

3-2. GENUINE PARTS

Use only genuine Henny Penny parts in your fryer. Using a part of lesser quality or substitute design may result in damage to the unit or personal injury.

3-3. WHEN ORDERING PARTS

Once the parts that you want to order have been found in the parts list, write down the following information:

Item Number	<u>2</u>	
Part Number	<u>16738</u>	Example:
Description	<u>High Limit</u>	

From the data plate, list the following information:

Product Number	<u>01100</u>	
Serial Number	<u>0001</u>	Example:
Voltage	<u>208</u>	

3-4. PRICES

Your distributor has a price parts list and will be glad to inform you of the cost of your parts order.

3-5. DELIVERY

Commonly replaced items are stocked by your distributor and will be sent out when your order is received. Other parts will be ordered, by your distributor, from Henny Penny Corporation. Normally, these will be sent to your distributor within three working days.

3-6. WARRANTY

All replacement parts (except lamps and fuses) are warranted for 90 days against manufacturing defects and workmanship. If damage occurs during shipping, notify the carrier at once so that a claim may be properly filed. Refer to warranty in the front of this manual for other rights and limitations.

3-7. RECOMMENDED SPARE PARTS FOR DISTRIBUTORS

Recommended replacement parts, stocked by your distributor, are indicated with ✓ in the parts lists. Please use care when ordering recommended parts, because all voltages and variations are marked. Distributors should order parts based upon common voltages and equipment sold in their territory.

3-8. INDEX OF PARTS LIST ILLUSTRATIONS

Title	Fig. No.	Page No.
FRAME AND COVER ASSEMBLY	3-1	3-3
ELEMENT ASSEMBLY	3-2	3-5
COUNTERWEIGHT SYSTEM	3-3	3-6
LID ASSEMBLY	3-4	3-7
CONTROL PANEL ASSEMBLY	3-5	3-8
BEHIND CONTROL PANEL COMPONENTS	3-6	3-9
FILTER PUMP ASSEMBLY (BELOW SN: BE0401001)	3-7A	3-10
FILTER PUMP ASSEMBLY (SN: BE0401001 & ABOVE)	3-7B	3-12
DRAIN VALVE & DRAIN SWITCH ASSEMBLIES	3-8	3-14
DRAIN PAN AND FILTER ASSEMBLY	3-9	3-15
CARRIER, RACKS & JUNCTION BOX ASSY	3-10	3-17
OPTIONAL RINSE HOSE ATTACHMENTS (BELOW SN: BE0401001) ..	3-11A	3-18
OPTIONAL RINSE HOSE ATTACHMENTS (SN: BE0401001 & ABOVE)	3-11B	3-19
OPTIONAL DIRECT-CONNECT KIT (SN: BE0401001 & ABOVE only) ..	3-12	3-20

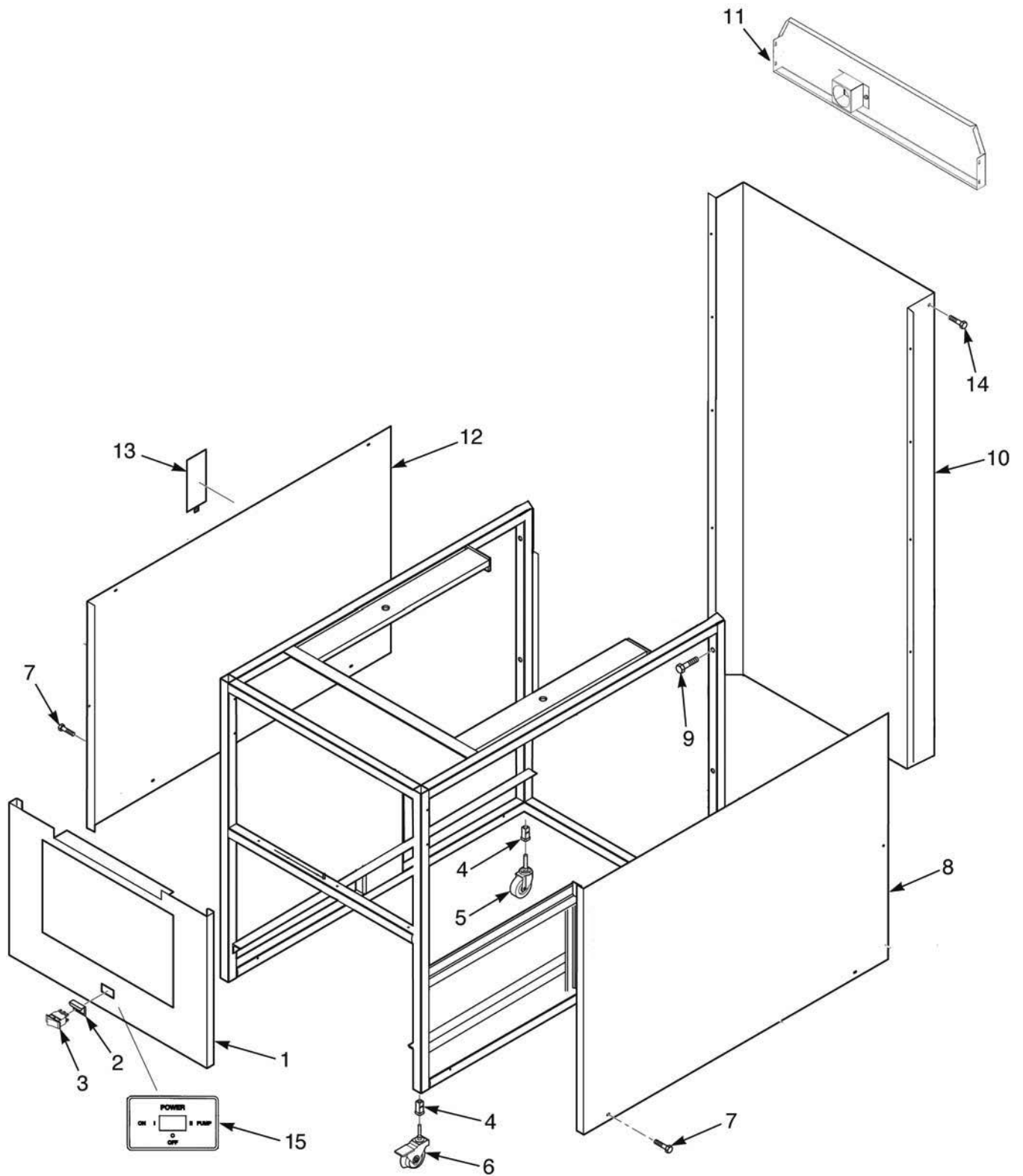

Figure 3-1. Frame and Cover Assembly

Figure & Item No.	Part No.	Description	Qty.
3-1		FRAME & COVER ASSEMBLY	
1	39796	WELDMENT – CONTROL PANEL FRONT	1
2	53669	GUARD – POWER SWITCH	1
√ 3	29898	SWITCH – POWER	1
4	54225	1" INSERT – LEG MACHINED	4
5	53673	CASTER, SWIVEL 4"	2
6	37246	CASTER W/BRAKE & SWIVEL LOCK	2
7	SC03-005	SCREW - - #8 x 1/2" PH PHD	4
8	66934	SIDE PANEL – RIGHT	1
9	SC01-215	SCREW - 5/16-18 x 2.5" HEX HD BOLT	4
10	37291	REAR SHROUD – ACCESS ASSEMBLY	1
11	35726	TOP COVER – REAR SHROUD	1
12	66933	SIDE PANEL – LEFT	1
13	36337	DOOR – ACCESS	1
14	SC02-023	SCREW - #8-B x 3/8" PH THD SS	5
15*	14457	KIT - SOUND DEADENING (PUMP NOISE)	1

√ recommended parts

* not shown

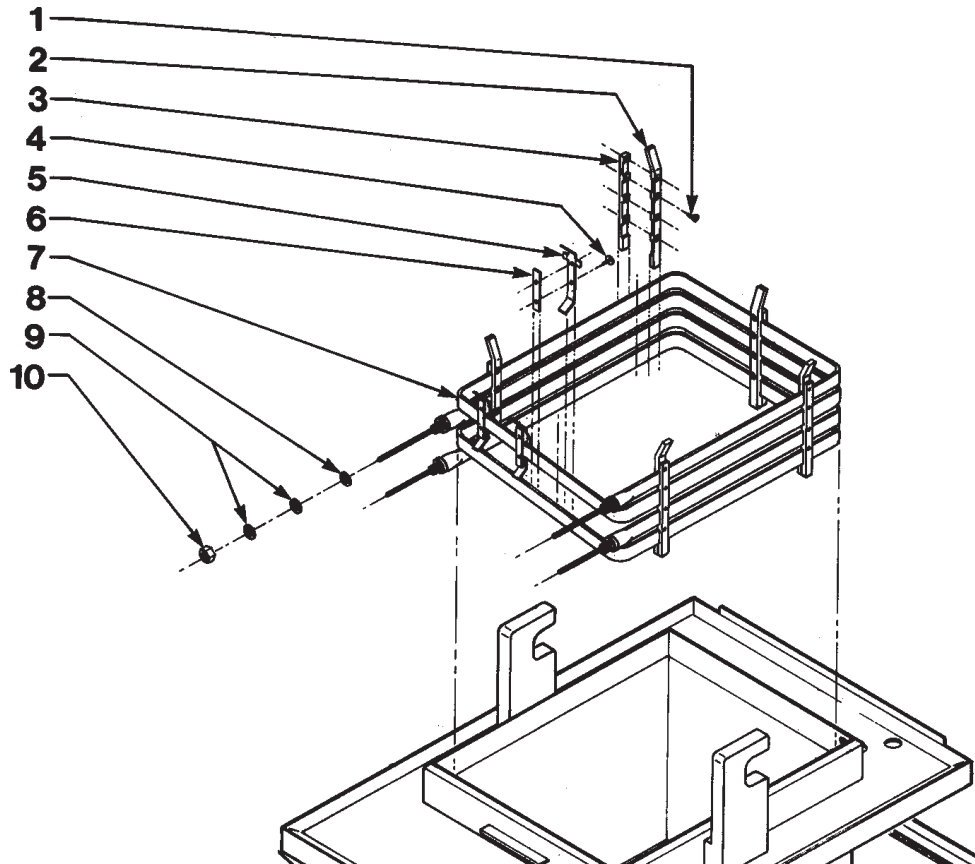

Figure & Item No.	Part No.	Description	Qty.
3-2		ELEMENT ASSEMBLY	
1	SC01-083	SCREW, (#10-32 x 1/2 PH FHD)	As Required
2	35101	SUPPORT, ELEMENT - LONG	5
3	35100	SUPPORT, ELEMENT - SHORT	5
4	SC01-074	SCREW, (#10-32 x 1/2 PH THD S)	As Required
5	35435	BRACKET, HI LIMIT PROBE	3
6	35462	BRACKET, HI LIMIT PROBE	3
√ 7	35234	HEAT ELEMENT ASSEMBLY, 8.5 KW 208V	2
√ 7	35598	HEAT ELEMENT, 8.5 KW 240V	2
√ 7	48367	HEAT ELEMENT, 230 V(Int'l Only)	2
√ 7	36290	HEAT ELEMENT, 220 V(Int'l Only)	2
8	16855	SEAL, O-RING	4
9	WA01-005	WASHER, (5/8 DIA. TYPE A - SERIES N)	8
10	NS01-017	NUT, (5/8-18 B HEX)	4

√ recommended parts

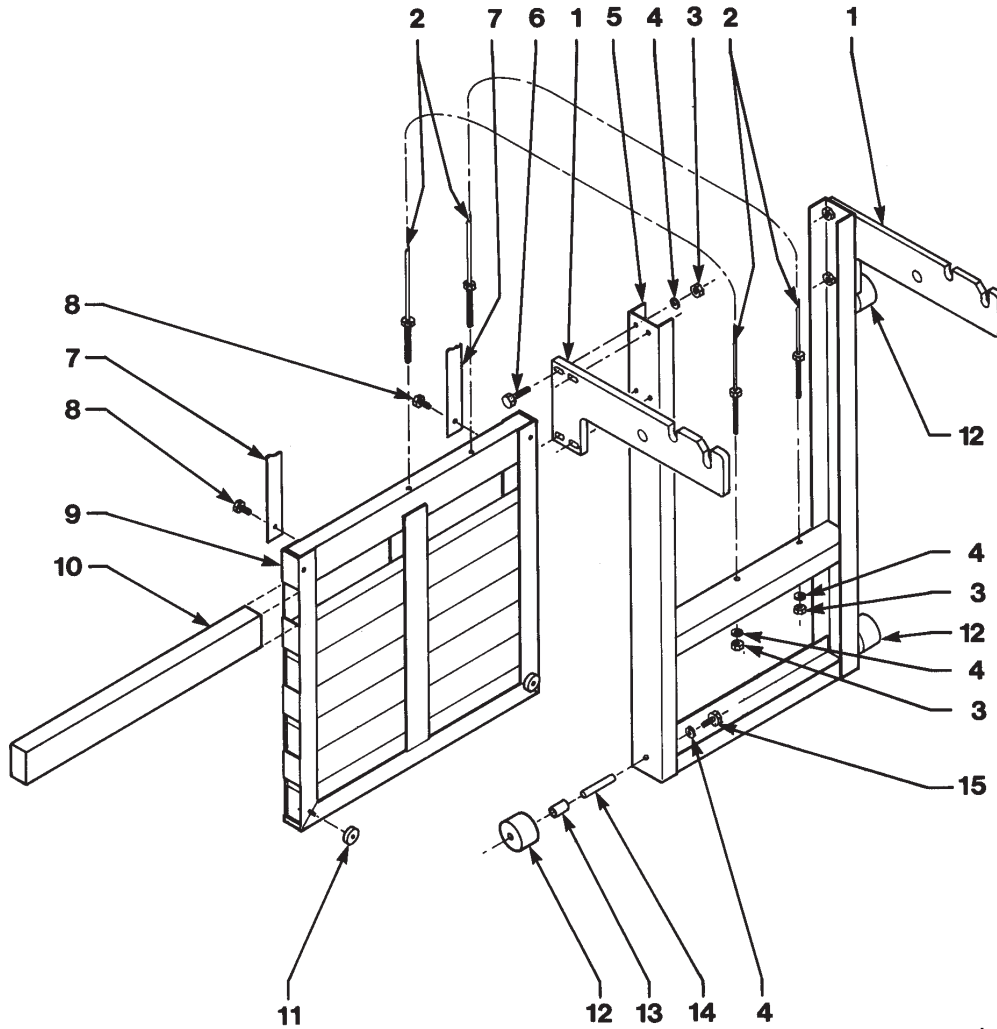

Figure & Item No.	Part No.	Description	Qty.
3-3		COUNTERWEIGHT SYSTEM	
1	35026	ARM, LID SUPPORT	2
√ 2	35207	CABLE	2
3	NS01-025	NUT, HEX 5/16-18 SS	10
4	LW01-010	WASHER, 3/8 SPLIT RING SS	10
5	35092	CARRIAGE	1
6	SC01-069	SCREW, 3/8-16 X 1-1/2 HEX HD S2P	8
7	36839	SLIDE	2
8	SC01-042	SCREW, 3/8-16 X 1 HEX C	2
9	36625	WELD ASSEMBLY, C/W CARRIAGE	1
10	36627	COUNTERWEIGHT BAR	4
11	36626	SPACER, C/W FRAME	2
12	37362	WHEEL, CARRIAGE	4
13	37363	SPACER, CARRIAGE WHEEL	4
14	37364	SPINDLE	4
15	SC01-081	SCREW, 3/8-24 X 3/4 HEX HD SS	4

√ recommended parts

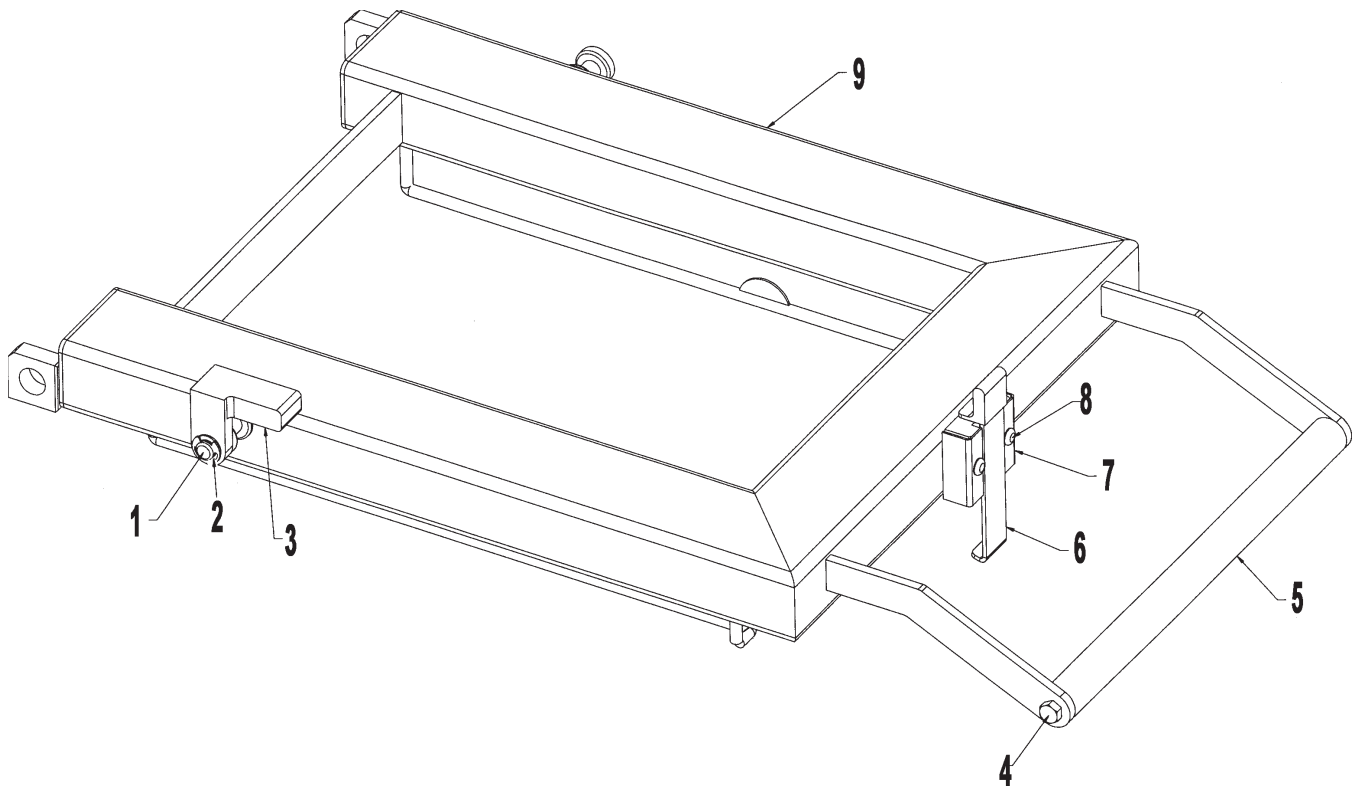

Figure & Item No.	Part No.	Description	Qty.
3-4	65818	Lid Assembly Complete	
1	RR01-004	Ring - Retaining - 1/2 in.	1
2	WA01-020	Washer - .513 ID-.750 OD-.05 THK	1
3	51531	Stop - Lid, Cast	1
4	SC01-041	Screw - 5/16"-18 x 1 HEX HD C	2
5	55754	Handle Weld Assembly	1
6	55756	Assy. - Latch/Sleeve Coat	1
7	59169	Lid Latch Bracket	1
7a	52498	Spring - Lid Latch	1
7b	51707	Lid Latch Bracket	1
8	SC01-248	Screw 10-32 x 1.25 PH THD SS	2
9	65817	Weldment 290 Lid	1

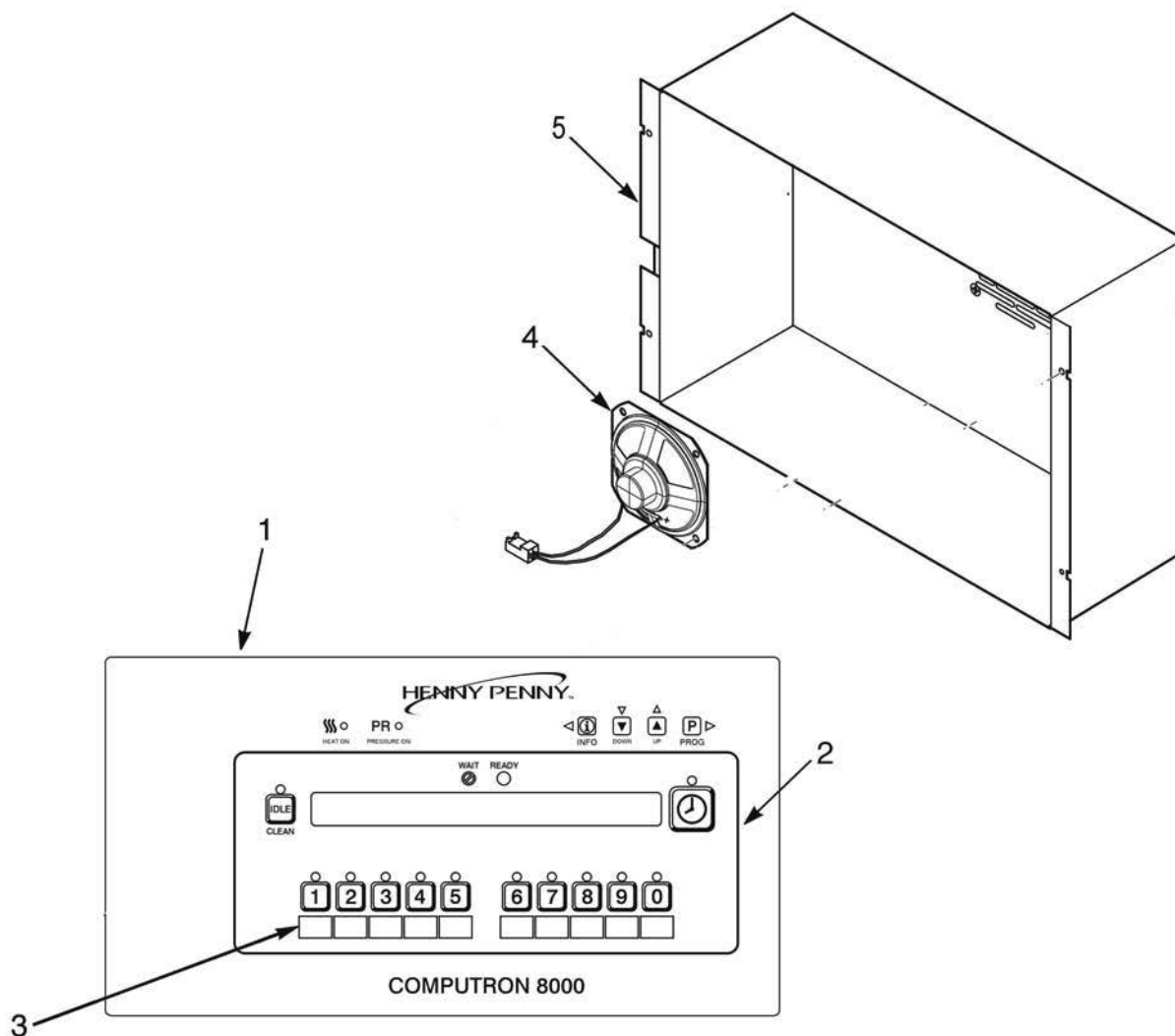

Figure & Item No.	Part No.	Description	Qty.
3-5		CONTROL PANEL ASSEMBLY	
√ 1	65279RB	ASSY - 8 HEAD C8000 CONTROL	1
2	65236	DECAL - 8 HEAD C8000	1
3	32634	MENU CARD C8000 BLANK	1
3	65922	MENU CARD C8000 8-HD HP GM	1
√ 4	26974	WIRE/SPEAKER ASSY	1
5	65661	STUD ASSY-8-HEAD-C8000- COVER	1
6*	65893RB	ASSY - I/O BOARD	1
7*	14688	KIT, 290 TO 291 CONVERSION	1
7*	14692	KIT, 292 TO 291 CONVERSION	1

√ recommended parts

* not shown



Figure & Item No.	Part No.	Description	Qty.
3-6		BEHIND CONTROL PANEL COMPONENTS	
√ 1	29942	CONTACTOR - MERCURY 208/240 VAC	1
√ 1*	65075	ASSY.-240V E/M HEAT CONTACTOR-CE-240V (UK)	1
√ 1*	65074	ASSY.-240V E/M HEAT CONTACTOR-CE-230V ..	1
√ 2	29901	CAPACITOR-RESISTOR ASSY	1
√ 3	19405	CONTACTOR KIT - 208/240 VAC	1
4	17216	BRACKET ASSY-HIGH LIMIT	1
√ 5	16738	450° F HIGH LIMIT	1
√ 5	60241	425° F HIGH LIMIT - CE	1
√ 6	EF02-125	BREAKER-PUSH BUTTON RESET-15 AMP	2
		SN: BE0608003 & ABOVE	
√ 6	18364	FUSE HOLDER ASSY - 15 AMP	2
		SN: BE0608002 & BELOW	
√ 6	EF02-006	FUSE HOLDER	2
√ 6	EF02-007	FUSE - 15 AMP	2
√ 6	EF02-104	FUSE HOLDER - 20A-250V	1
√ 6	EF02-007	FUSE - 15 AMP - CE	1
√ 7	14335	PROBE KIT	1
√ 8*	72854	ASSY - TRANSFORMER - 24VAC - C8000	1

√ recommended parts/* not shown

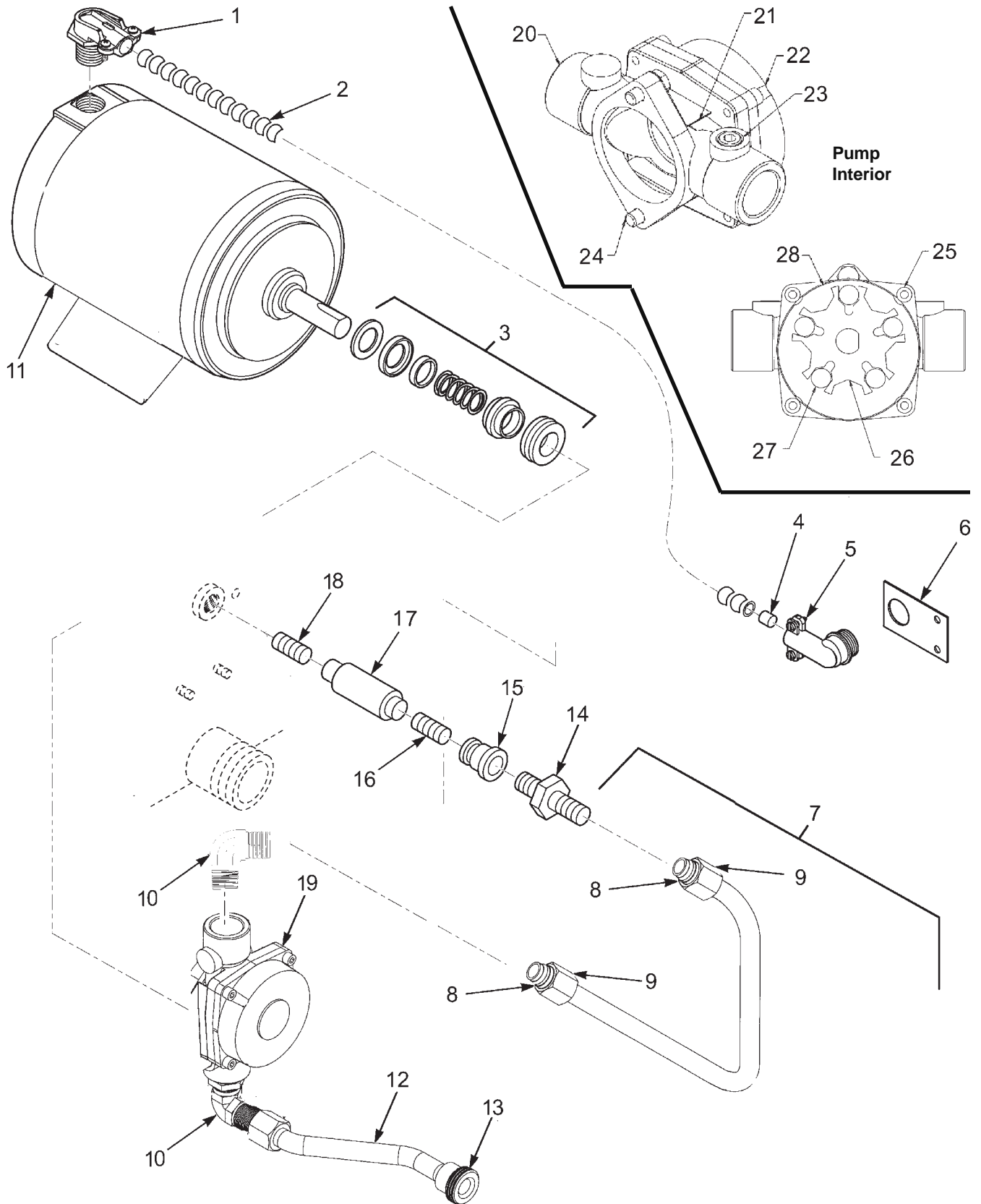

3-7A. FILTER PUMP ASSEMBLY (BELOW SN: BE0401001)

Figure & Item No.	Part No.	Description	Qty.
3-7A		FILTER PUMP ASSEMBLY	
1	18107	CONDUIT CONNECTOR 3/8 X 90	1
2	54484	BLOWER/PUMP – FLEXIBLE CONDUIT	1
√ 3	17476	PUMP SEAL KIT	1
4	18105	ANTI SHORT 3/8 INCH	2
5	18644	CONDUIT CONNECTOR 3/8 X 90	1
6	51831	PUMP CONDUIT BRACKET	1
7	55836	ASSY – OIL RETURN LINE	1
8	16808	SLEEVE, FITTING	2
9	16809	NUT, FITTING	2
10	17407	CONNECTOR, 1/2 MALE ELBOW	2
√ 11	67583	MOTOR – FILTER PUMP	1
12	62206	ASSY - TUBE - PUMP TO DISCON - 590	1
√ 13	17430(use 69289)	UNION, MALE FITTING	1
14	16807	FITTING, CONNECTOR MALE	1
15	FP01-122	REDUCER, 3/8 TO 1/2	1
16	FP02-024	NIPPLE, CLOSE 3/8	1
17	35472	CHECK VALVE - PRESSURE	1
18	FP02-007	NIPPLE 3/8 X 1-1/2	1
19	17437	PUMP SUBASSY 8GPM	1
√ 20	17454	BODY - PUMP	1
√ 21	17456	PUMP SHIELD	2
√ 22	17451	COVER - PUMP	1
√ 23	SC01-016	PLUG 1/4 HEX COUNTERSUNK	1
√ 24	SC01-026	SCREW 5/16-18 X 3/4 HEX HD C	2
√ 25	SC01-132	1/4-20 X 5/8 SOC HD CAP SCREW	4
√ 26	17447	ROTOR - PUMP	1
√ 27	17446	ROLLER - TEFLON SET	1
√ 28	17453	PUMP O RING GASKET	1
29*	14676	KIT, 1/2" PUMP AND MOTOR	1

√ recommended parts

* not shown

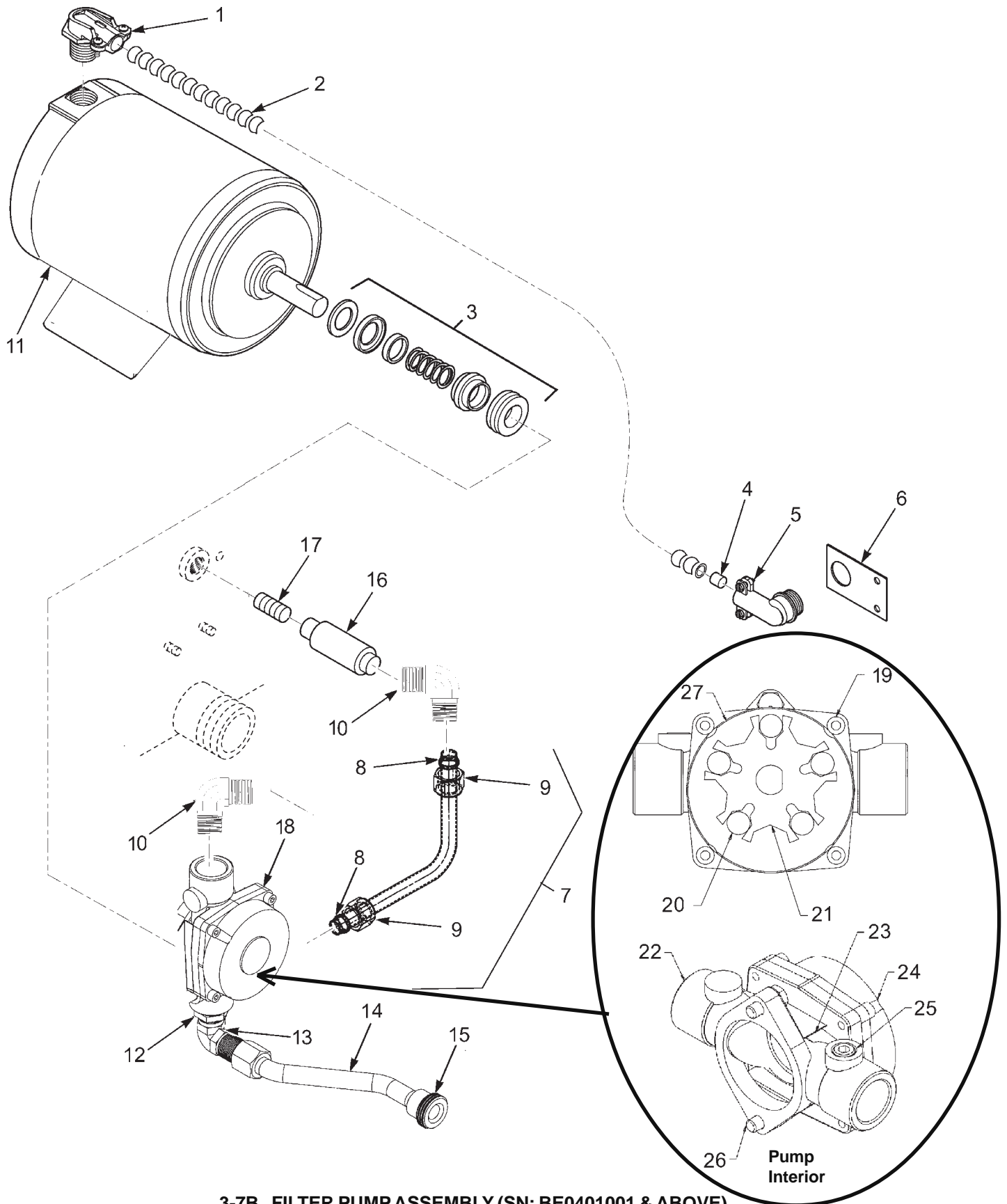

3-7B. FILTER PUMP ASSEMBLY (SN: BE0401001 & ABOVE)

Figure & Item No.	Part No.	Description	Qty.
3-7B		FILTER PUMP ASSEMBLY	
1	18107	CONDUIT CONNECTOR 3/8 X 90	1
2	54484	BLOWER/PUMP – FLEXIBLE CONDUIT	1
√ 3	17476	PUMP SEAL KIT	1
4	18105	ANTI SHORT 3/8 INCH	2
5	18644	CONDUIT CONNECTOR 3/8 X 90	1
6	51831	PUMP CONDUIT BRACKET	1
7	66618	ASSY – OIL RETURN LINE	1
8	16808	SLEEVE, FITTING	2
9	16809	NUT, FITTING	2
10	FP01-169	CON-90 MALE 3/4 TUBE 3/4 NPT	2
√ 11	67583	MOTOR – FILTER PUMP	1
12	FP01-089	BUSHING - REDUCING 3/4M TO 1/2F	1
13	17407	CONNECTOR, 1/2 MALE ELBOW	1
14	62206	ASSY - TUBE - PUMP TO DISCON	1
√ 15	17430(use 69289)	UNION, MALE FITTING	1
16	21800	VALVE - 3/4 CHECK	1
17	FP02-021	NIPPLE - 3/4 NPT X 3 IN LG BL	1
18	64218	PUMP SUBASSY 8GPM	1
√ 19	SC01-132	1/4-20 X 5/8 SOC HD CAP SCREW	4
√ 20	23469	ROLLER - 7 GPM PUMP	5
√ 21	23468	ROTOR - 7GPM PUMP	1
√ 22	23647	BODY - 7 GPM PUMP	1
√ 23	17456	PUMP SHIELD	2
√ 24	23470	CAP - 7 GPM PUMP	1
√ 25	FP01-020	PLUG 1/4-18 HEX LEVEL SEAL	1
√ 26	SC01-026	SCREW 5/16-18 X 3/4 HEX HD C	2
√ 27	17453	PUMP O RING GASKET	1
28*	69356	ASSY, 3/4” PUMP AND MOTOR	1

√ recommended parts

* not shown

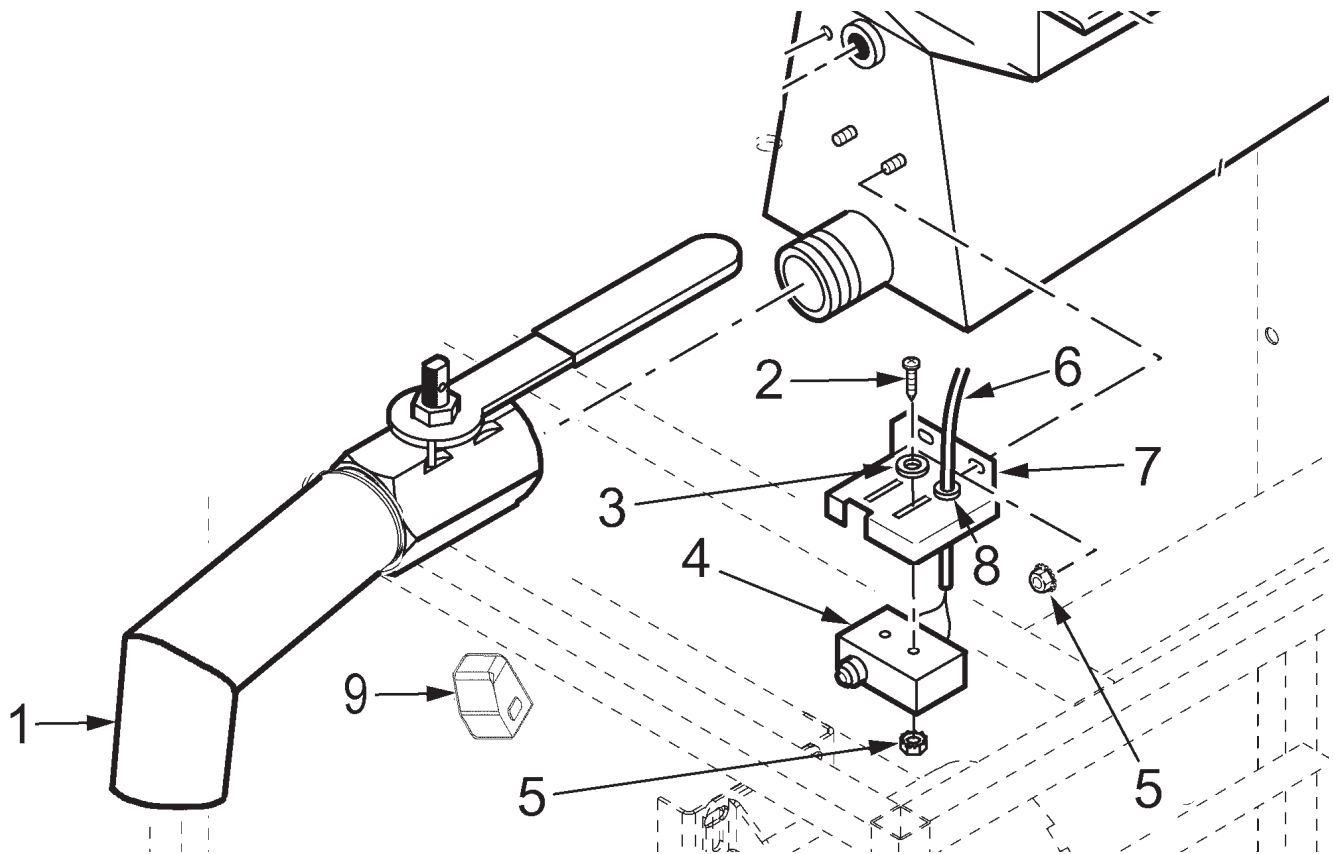
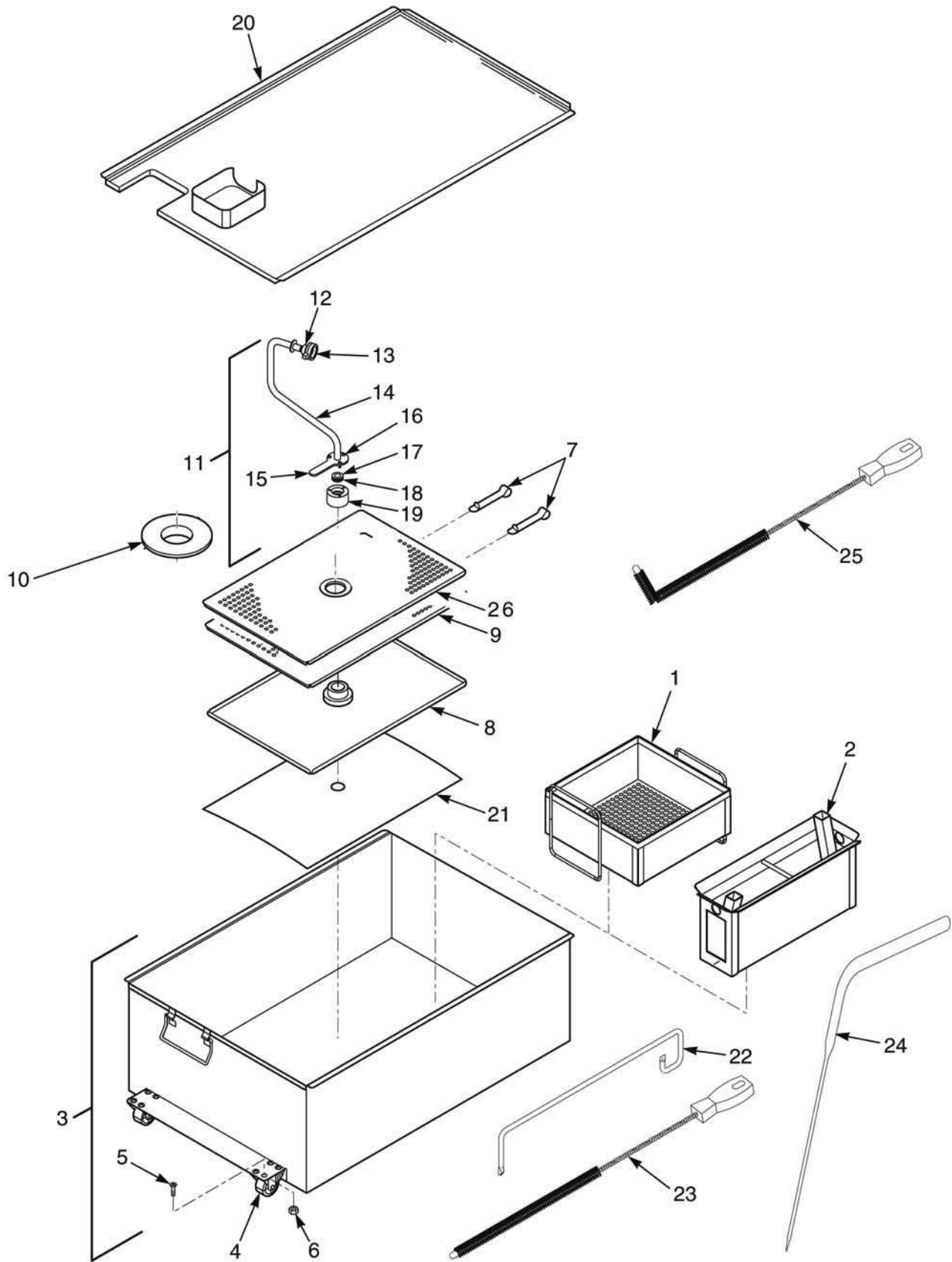

Figure & Item No.	Part No.	Description	Qty.
3-8		DRAIN VALVE & DRAIN SWITCH ASSEMBLIES	
1	65520	DRAIN VALVE ASSEMBLY (BELOW SN: BE0401001) .	1
1	66553	DRAIN VALVE ASSEMBLY (SN: BE0401001 & ABOVE)	1
2	SC01-058	SCREW #6-32 X 1 PH. PAN HD.	2
3	WA01-006	WASHER #6 TYPE A	2
√ 4	54228	DRAIN SWITCH W/BOOT	1
5	NS02-005	NUT #6-32 HEX	2
6	52519	CORD ASSY., DRAIN INTERLOCK	1
7	65522	BRACKET, SWITCH (BELOW SN: BE0404001)	1
7	67619	BRACKET, SWITCH (SN: BE0404001 & ABOVE)	1
8	EF02-017	STRAIN RELIEF	2
9	67617	BRACKET - MICROSWITCH TRIGGERING	1

√ recommended parts



3-9. DRAIN PAN AND FILTER ASSEMBLY

Figure & Item No.	Part No.	Description	Qty.
3-9		DRAIN PAN AND FILTER ASSEMBLY	
1	52194	CRUMB CATCHER (OPTIONAL)	1
2	03204	CRUMB CATCHER BASKET W/HANDLE (OPTIONAL)	1
2	21010	CRUMB CATCHER BASKET ASSEMBLY	1
2	24429	HANDLE - CRUMB BASKET	1
3	52496	FILTER DRAIN PAN ASSEMBLY	1
4	52487	CASTER	2
5	SC01-009	SCREW 1/4-20 X 1/2	8
6	NS02-002	NUT 1/4-20	8
7	17505	FILTER CLIPS	2
8	17503(use 14674)	BOTTOM FILTER SCREEN (SN:BE0503009 AND BELOW) ..	1
8	65447	BOTTOM FILTER SCREEN (SN: BE0503010 AND ABOVE) ..	1
9	17502(use 14674)	TOP FILTER SCREEN (SN:BE0503009 AND BELOW)	1
10	36305	WASHER & STANDPIPE	1
11	24212	STANDPIPE ASSEMBLY (SN:BE0503009 AND BELOW)	1
11	14658	KIT, 8 HEAD PICK-UP TUBE (SN: BE0503010 AND ABOVE)	
√ 12	17431(use 69289)	UNION - MALE FITTING	1
√ 13	17432(use 69289)	UNION - HANDLE FITTING	1
14	24211	WELDMENT, FILTER TUBE AND WASHER	1
15	23740	HANDLE, STANDPIPE 8 HEAD	1
16	SC01-245	SCREW 10-32 X 1/2	3
17	23804	INSERT, FILTER NUT	1
18	OR01-007	O-RING, FILTER NUT INSERT	1
19	23803	FILTER NUT (SN:BE0503009 AND BELOW)	1
19	66535	FILTER NUT (SN: BE0503010 AND ABOVE)	1
20	62082	FILTER DRAIN PAN COVER ASSEMBLY	1
√ 21	12102	FILTER ENVELOPE PAPER (100 PER CARTON) .	1
22	65776	ROD - LONG CLEAN OUT	1
√ 23	35771	BRUSH	1
24	35310	STIRRER	1
√ 25	12126	BLACK L-BRUSH	1
26	65211	CRUMB CATCHER	1

√ recommended parts

* not shown

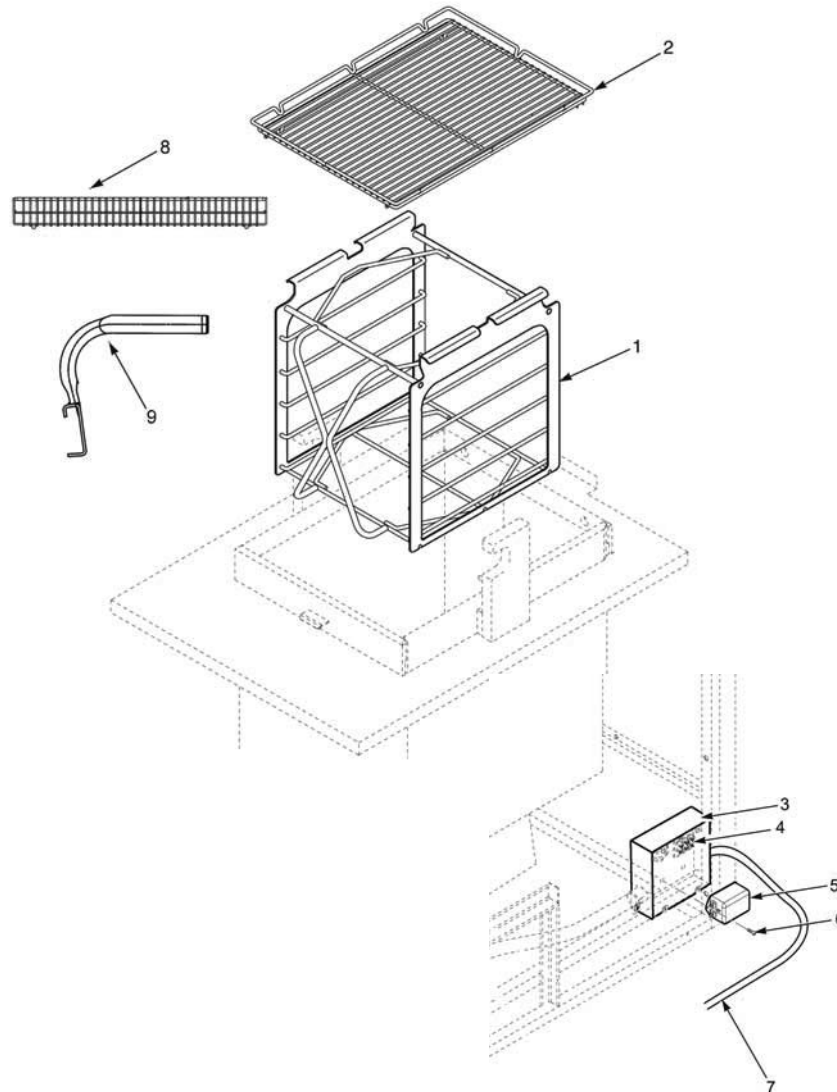
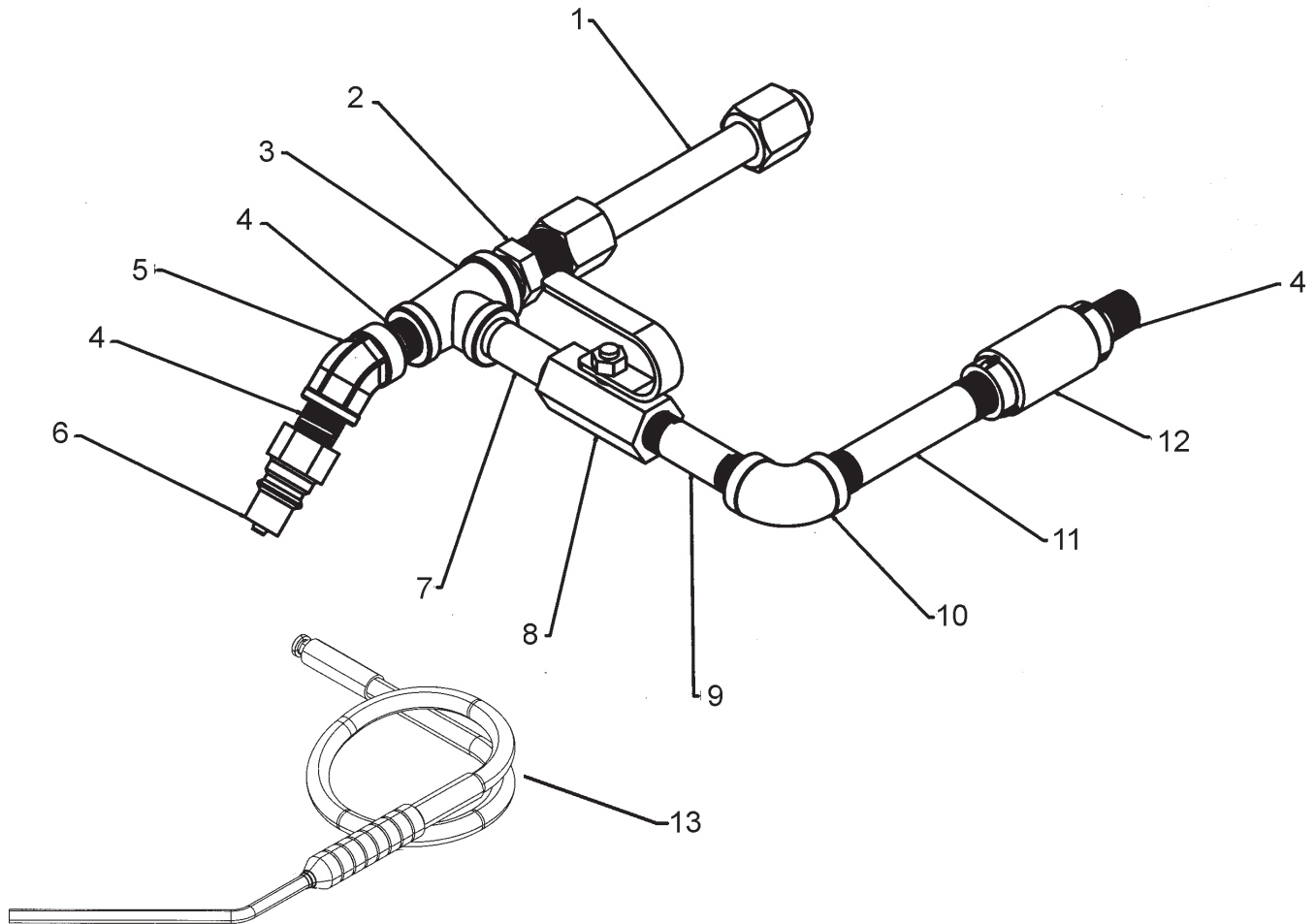

Figure & Item No.	Part No.	Description	Qty.
3-10		CARRIER, RACKS & JUNCTION BOX ASSY	
1	62183	CARRIER ASSY	1
2	44782	RACK HALF SIZE – 8 HEAD FRYER	1
3	62126	JUNCTION BOX ASSY	1
3	62127	JUNCTION BOX ASSY - CE	1
4	65427	ASSY - 5-POLE TERMINAL BLOCK - CE	1
√ 5	51057	ASSY - EMC FILTER - CE	1
6	SC01-023	SCREW #6-32 X 1/4 PH RHD C	8
7	65180	ASSY - MAIN POWER CORD	1
7	65181	CORD - 291/591 POWER	1
	58146*	PLUG-90, 60A, 3PH, 250V, #15-60P	1
8	36404	WIRE BASKET - GM 8 HEAD	4
9	36374	ASSY - BASKET HANDLE WELD	1
10*	19923	TRANSFORMER - LARGE - 480 VOLT	1

√ recommended parts/* not shown



3-11A. OPTIONAL RINSE HOSE ATTACHMENTS (BELOW SN: BE0401001)

Figure & Item No.	Part No.	Description	Qty.
3-11A		OPTIONAL RINSE HOSE ATTACHMENTS	
1	66677	ASSY - RINSE HOSE - TUBE - 291	1
2	16807	FITTING - MALE CONNECTOR	1
3	17306	PIPE TEE FITTING	1
4	FP02-024	NIPPLE - 3/8 NPT - CLOSE B. I.	3
5	FP01-133	ELBOW - 3/8 NPT X 45 - FEMALE	1
6	17334	RINSE HOSE DISCONNECT - MALE	1
7	FP02-042	NIPPLE - 3/8 X 2 LG B. I.	1
8	59185	VALVE - FILTER (SMALL C HANDLE)	1
9	FP02-043	NIPPLE - 3/8 NPT X 2.5 B. I.	1
10	17319	PIPE ELBOW - 3/8	1
11	FP01-116	NIPPLE - 3/8 NPT X 4" LG B. I.	1
12	35472	CHECK VALVE - PRESSURE	1
13	03003	DETACHABLE HOSE ASSEMBLY	1

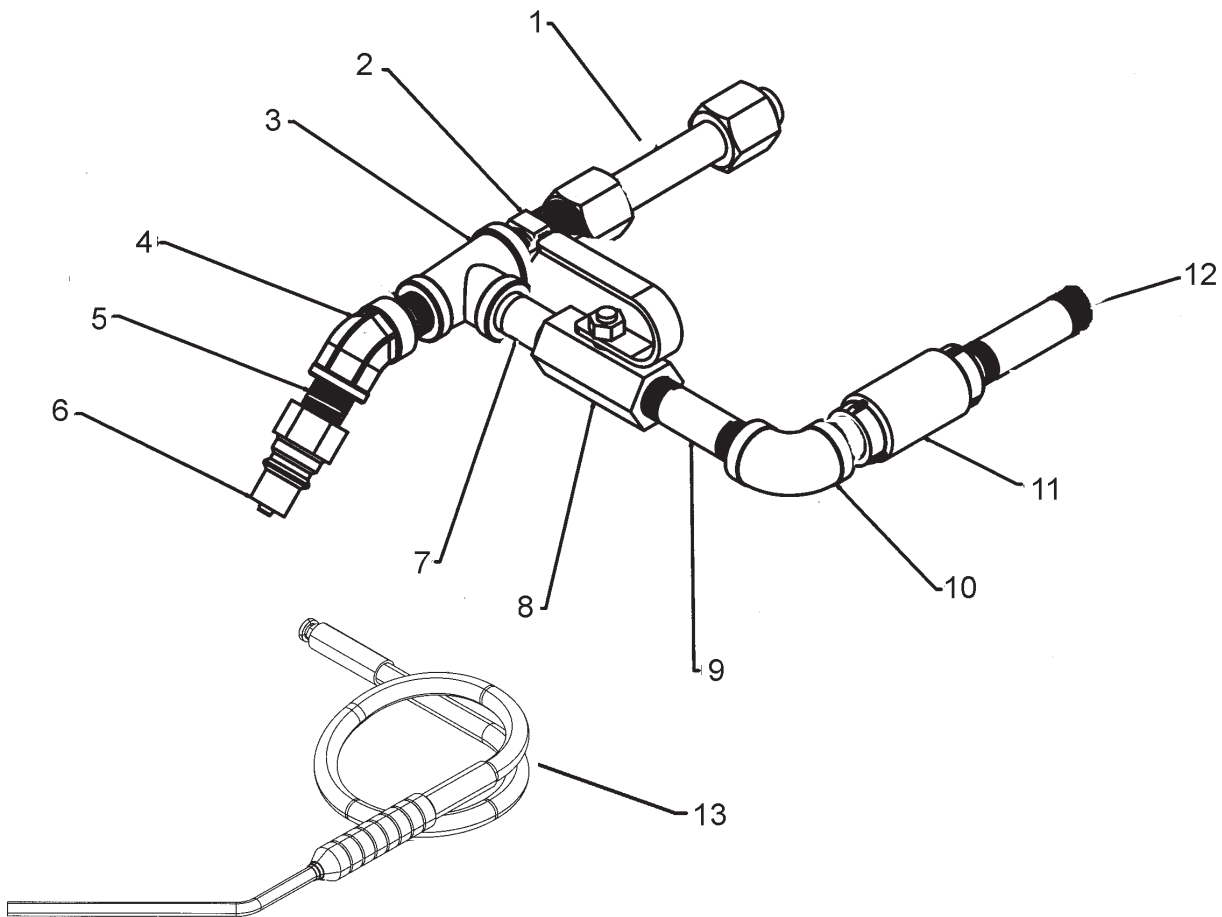

3-11B. OPTIONAL RINSE HOSE ATTACHMENTS(SN: BE0401001 & ABOVE)

Figure & Item No.	Part No.	Description	Qty.
3-11B		OPTIONAL RINSE HOSE ATTACHMENTS	
1	66450	ASSY -PUMP TO VALVE TUBE - 291	1
2	FP01-170	CON - 90 MALE 3/4 TUBE 3/4 NPT	1
3	FP01-171	TEE - 3/8 X 3/4 X 3/4 B. I.	1
4	FP01-172	ELBOW - 45 STREET 3/8 NPT B. I.	1
5	FP02-024	NIPPLE - 3/8 NPT - CLOSE B. I.	1
6	17334	RINSE HOSE DISCONNECT - MALE	1
7	FP02-044	NIPPLE - 3/4 X 2 LG B. I.	1
8	23430	VALVE - 3/4 INLET - E34X	1
9	16282	NIPPLE - 3/4 X CLOSE	1
10	FP01-100	ELBOW - STREET 3/4 NPT B. I.	1
11	21800	VALVE - 3/4 CHECK	1
12	FP02-021	NIPPLE - 3/4 NPT X 3 IN LG B. I.	1
13	03003	DETACHABLE HOSE ASSEMBLY	1

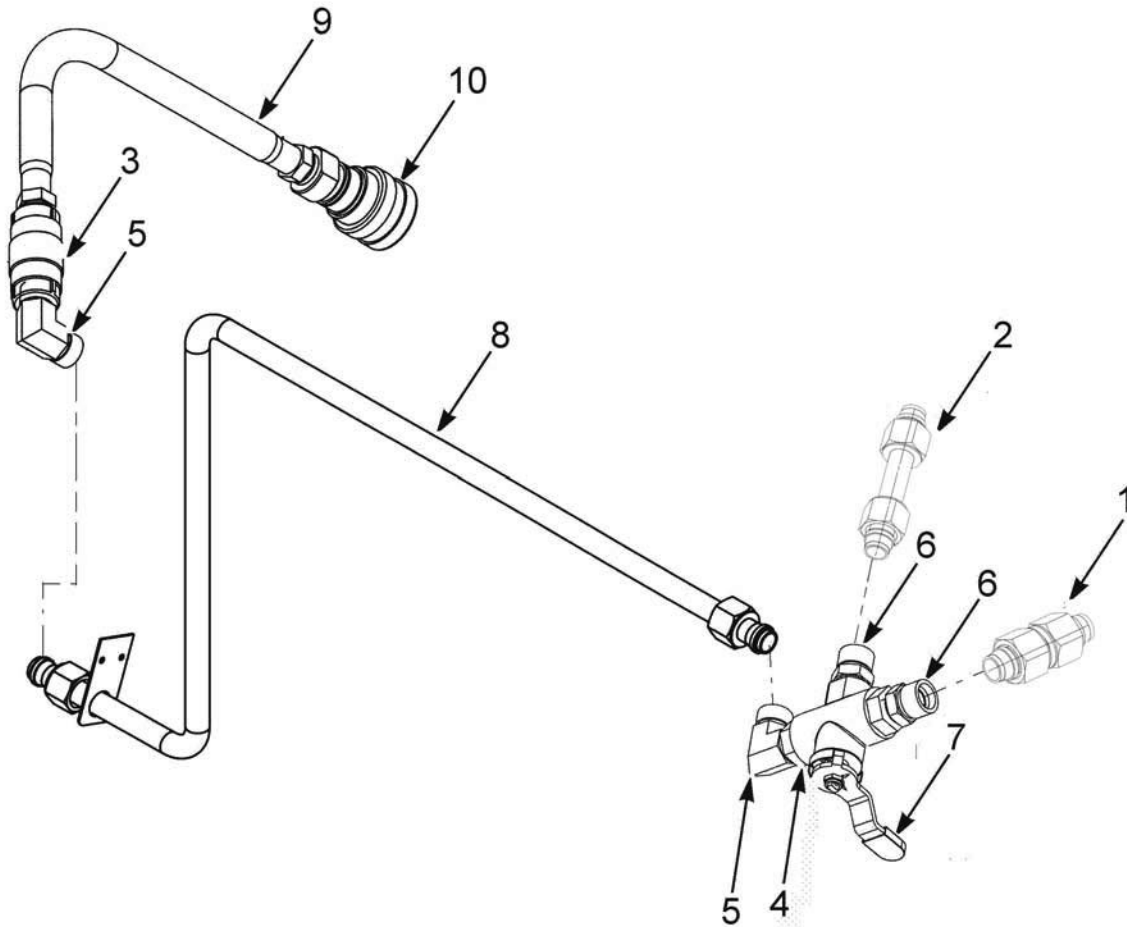

Figure & Item No.	Part No.	Description	Qty.
3-12	14638	OPTIONAL DIRECT-CONNECT KIT	1
		(SN: BE0401001 & ABOVE only)	
1	67695	ASSY - TUBE DC POT TO DIVERTER	1
2	66450	ASSY - TUBE DC DIVERTER TO POT	1
3	21800	VALVE - 3/4 CHECK	1
4	68510	VALVE - 3/4 DIVERTER W/O HANDLE	1
5	FP01-169	CON - 90 MALE 3/4 TUBE 3/4 NPT	2
6	FP01-170	CON - STR MALE 3/4 NPT	1
7	68126	HANDLE - 8 HEAD DIRECT CONNECT	1
8	67692	ASSY - DIRECT CONN TUBE 8 HEAD	1
9	21753	HOSE - SHORTENING DISCARD	1
10	21612	DISCONNECT - FEMALE	1