

SECTION 2. PARTS INFORMATION

2-1. INTRODUCTION

This section identifies and lists the replaceable parts of the Henny Penny Multipurpose Holding Cabinets.

2-2. GENUINE PARTS

Use only genuine Henny Penny parts in your cabinet. Using a part of lesser quality or substitute design may result in cabinet damage or personal injury.

2-3. HOW TO ORDER

Once the part you want to order has been found in the Parts List, write down the following information:

1. From the Parts List:

(Sample)

Item Number	<u>1</u>
Part Number	<u>51718</u>
Description	<u>Gasket – Drawer</u>

2. From the data plate:

(Sample)

Product Number	<u>05882</u>
Serial Number	<u>0001</u>
Voltage	<u>120V</u>

2-4. PRICES

Your independent Henny Penny distributor has a price parts list and will be glad to inform you of the cost of your parts order.

2-5. DELIVERY

Commonly replaced items are stocked by your independent Henny Penny distributor and will be sent out when your order is received. Other parts will be ordered by the distributor from Henny Penny Corporation. Normally, these will be sent to your distributor within three working days.

2-6. WARRANTY

All replacement parts (except lamps and fuses) are covered under warranty for 90 days against manufacturing defects and workmanship. If damage occurs during shipping, notify the carrier at once so that a claim may be properly filed. Refer to warranty on the front of this section for other rights and limitations.

2.7. RECOMMENDED SPARE PARTS FOR DISTRIBUTORS

Recommended replacement parts, stocked by your distributor, are indicated with √ in the parts lists. Please use care when ordering recommended parts, because all voltages and variations are marked. Distributors should order parts based upon common voltages and equipment sold in their territory.

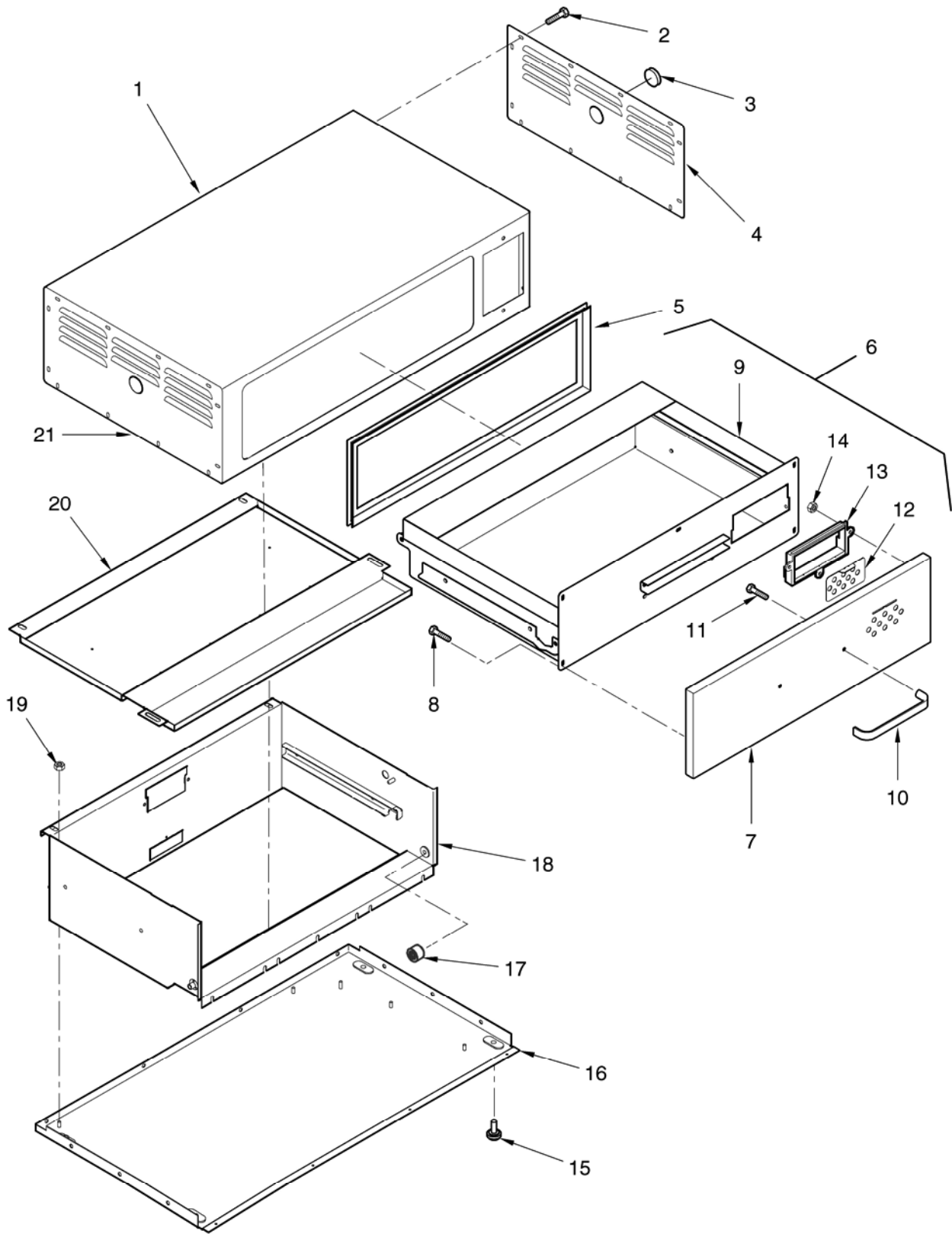

Figure 2-1. Shell and Drawer

FIG. & ITEM NO.	PART NO.	DESCRIPTION	QTY 941	QTY 942	QTY 943	QTY 944
2-1		SHELL AND DRAWER				
1	51514	SHELL ASSY. - 941	1	-	-	-
1	52626	SHELL ASSY. - 942 - RH	-	1	-	-
1	52649	SHELL ASSY. - 942 - LH	-	1	-	-
1	52650	SHELL ASSY. - 943 - RH	-	-	1	-
1	52651	SHELL ASSY. - 943 - LH	-	-	1	-
1	52652	SHELL ASSY. - 944 - RH	-	-	-	1
1	52653	SHELL ASSY. - 944 - LH	-	-	-	1
2	SC01-034	SCREWS	10	10	10	10
3	PL01-014	PLUG - 1 1/16"	2	3	3	1
4	51306	PANEL - ACCESS - RH	1	1	1	-
4	51912	PANEL - RH - SIDE ACCESS - 944	-	-	-	1
√	5	51718 GASKET - DRAWER	1	2	3	4
6	49548	DRAWER ASSY.	1	2	3	4
7	49554	. DRAWER FRONT ASSY.	1	2	3	4
8	SC02-016	. SCREW, FRONT RETAINING	5	10	15	20
9	49550	. DRAWER WELD ASSY.	1	2	3	4
10	31395	. DRAWER HANDLE	1	2	3	4
11	SC01-144	. SCREW, HANDLE RETAINING	2	4	6	8
12	51497	. SLIDE VENT	1	2	3	4
13	27501	. MOLDED BLOCK - VENT	1	2	3	4
14	NS02-006	. NUT	3	6	9	12
15	26411	FOOT	4	4	5	-
16	51503	BASE ASSY. - 941	1	-	-	-
16	53639	BASE ASSY. - 942 - RH	-	1	-	-
16	52640	BASE ASSY. - 942 - LH	-	1	-	-
16	52641	BASE ASSY. - 943 - RH	-	-	1	-
16	52642	BASE ASSY. - 943 - LH	-	-	1	-
√	17	14113 BEARING KIT	1	2	3	4
18	51505	LINER WELD ASSY.	1	2	3	4
19	NS02-002	NUT	4	8	12	16
20	52131	LINER - TOP STUD ASSY.	1	2	3	4
21	51097	PANEL - ACCESS - LH	1	1	1	-
21	51912	PANEL - ACCESS - LH	-	-	-	1
22*	52701	DECAL - TEMP. CALIBRATION	1	1	1	1

√ recommended parts
*not shown

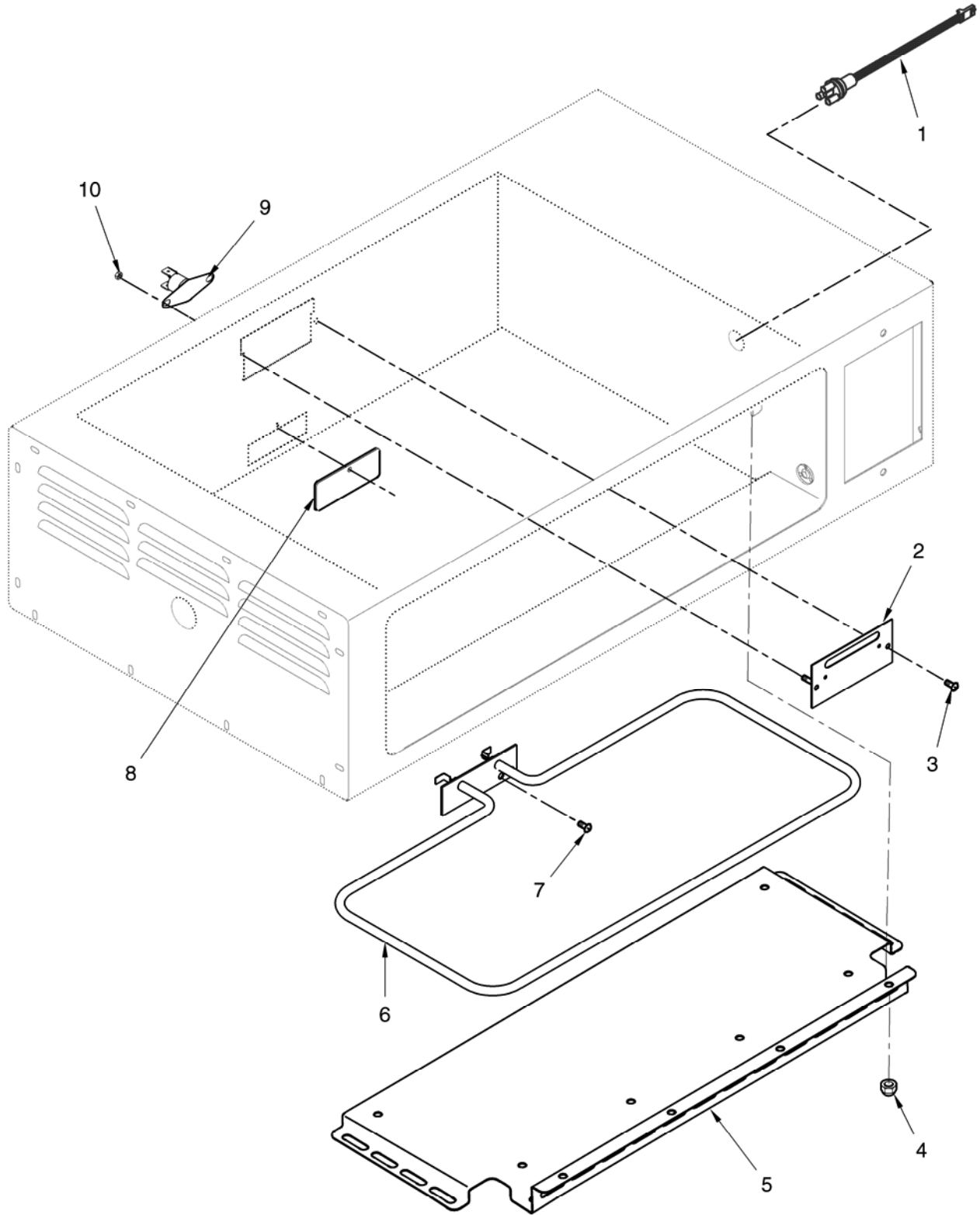

Figure 2-2. Heater and Cover Plate

FIG. & ITEM NO.	PART NO.	DESCRIPTION	QTY 941	QTY 942	QTY 943	QTY 944
2-2		HEATER AND COVER PLATE				
√ 1	52100	TEMPERATURE SENSOR ASSY.	1	2	3	4
2	51951	BRACKET – HEATER (BEFORE SN: GA0407031)	1	2	3	4
3	SC01-034	SCREW	2	4	6	8
4	NS03-024	ACORN NUT	3	6	9	12
5	51329	DEFLECTOR – HEAT(BEFORE APRIL 1, 2001)	1	2	3	4
5	70793	DEFLECTOR – HEAT(APRIL 1, 2001 & AFTER)	1	2	3	4
√ 6	51796	HEATER - 475 W. - 120 V.	1	2	3	4
√ 6	51932	HEATER - 475 W. - 240 V.	1	2	3	4
7	SC02-041	SCREW	2	2	2	2
8	51325	PLATE - HEATER COVER	1	2	3	4
√ 9	18201	HIGH LIMIT - 335° F	1	2	3	4
10	NS02-005	NUT	2	2	2	2
11*	51468	INSULATION - NON-CONTROL SIDE RH	1	1	1	-
11*	52689	INSULATION - LINER - CONTROL SIDE LH	-	1	1	-
11*	51473	INSULATION - LINER - CONTROL SIDE RH	-	-	-	1
11*	52691	INSULATION - LINER - CONTROL SIDE LH	-	-	-	1
11*	51469	INSULATION - SHELL TOP	1	2	3	4
11*	51470	INSULATION - LINER - BOTTOM	1	2	3	4
11*	51471	INSULATION - LINER - REAR - LOWER	1	2	3	4
11*	51472	INSULATION - LINER - REAR - TOP	1	2	3	4
11*	51474	INSULATION - LINER - TOP	1	2	3	4
11*	52093	INSULATION - LINER - TOP	1	-	-	4
11*	51475	INSULATION - CONTROL SIDE RH	1	1	1	-
11*	52690	INSULATION - LINER - NON-CONTROL SIDE LH	-	1	1	-
11*	51116	INSULATION - LINER - NON-CONTROL SIDE RH	-	-	-	1
11*	52692	INSULATION - LINER - NON-CONTROL SIDE LH	-	-	-	1

√ recommended parts
*not shown

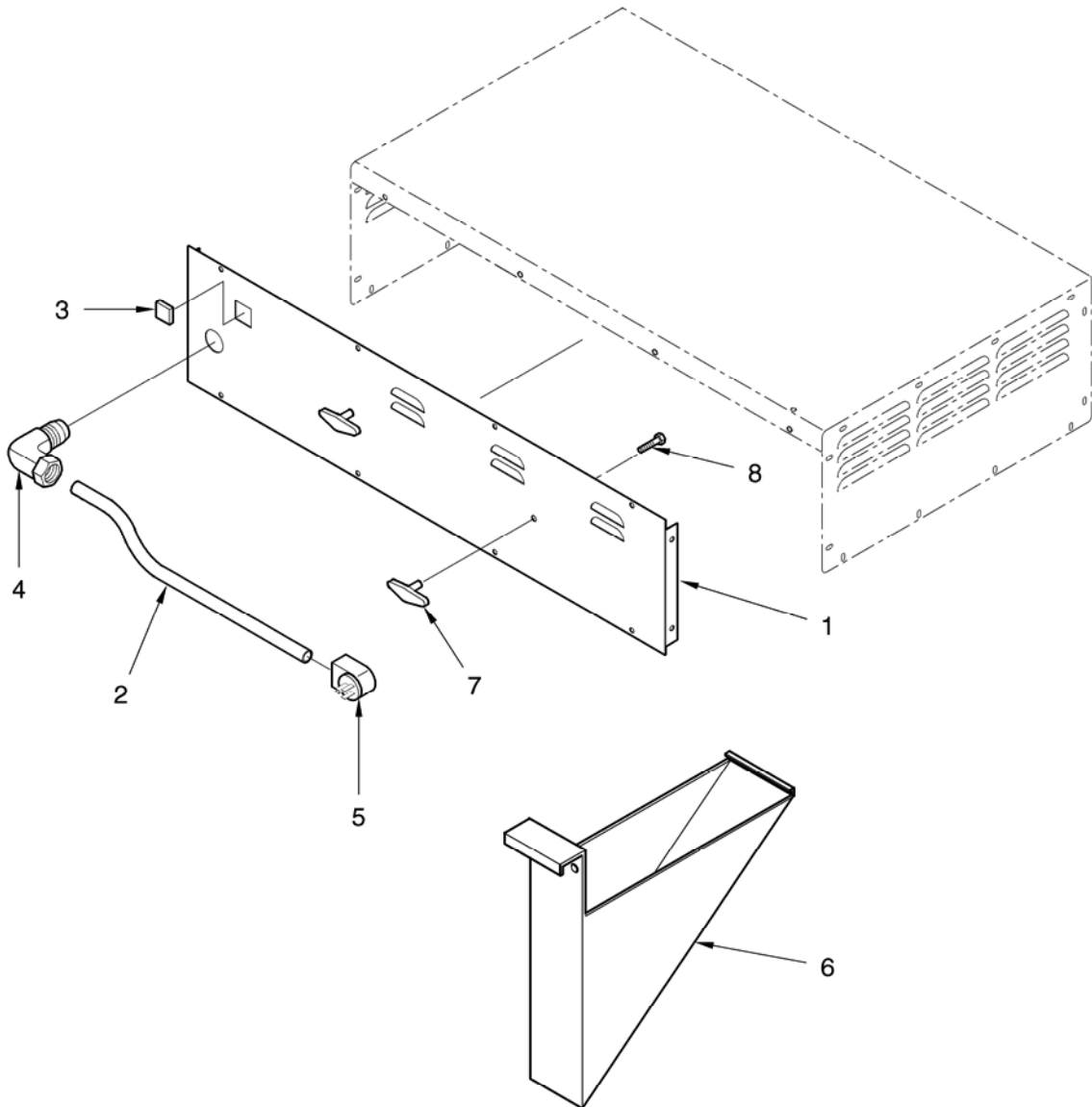

Figure 2-3. Rear Panel

FIG. & ITEM NO.		PART NO.	DESCRIPTION	QTY 941	QTY 942	QTY 943	QTY 944
2-3			REAR PANEL				
3	1	51297	REAR ACCESS PANEL - 941	1	-	-	-
3	1	51351	REAR ACCESS PANEL - 942	-	1	-	-
3	1	51947	REAR ACCESS PANEL - 943	-	-	1	-
3	1	52647	REAR ACCESS PANEL STUD ASSY.	-	-	-	1
3	2	40297	POWER CORD ASSY.	1	1	1	-
3	2	27555	POWER CORD ASSY. - 944	-	-	-	1
3	2	63837	POWER CORD ASSY. - CE	1	2	3	4
3	3	MS01-197	RECEPTACLE - NEMA 5-15 R	1	-	-	-
3	4	27639	STRAIN RELIEF	1	1	1	1
3	5	40298	PLUG - ANGLED - 125 V. - 15 AMP	1	1	1	-
3	5	27692	PLUG - ANGLED - 125 V - 20 AMP	-	-	-	1
3	6	52676	MIDDLE SUPPORT BRACKET - 944	-	-	-	1
3	7	27645	KNOB - CORD WRAP - 941	2	-	-	-
3	8	SC01-172	SCREW	4	-	-	-

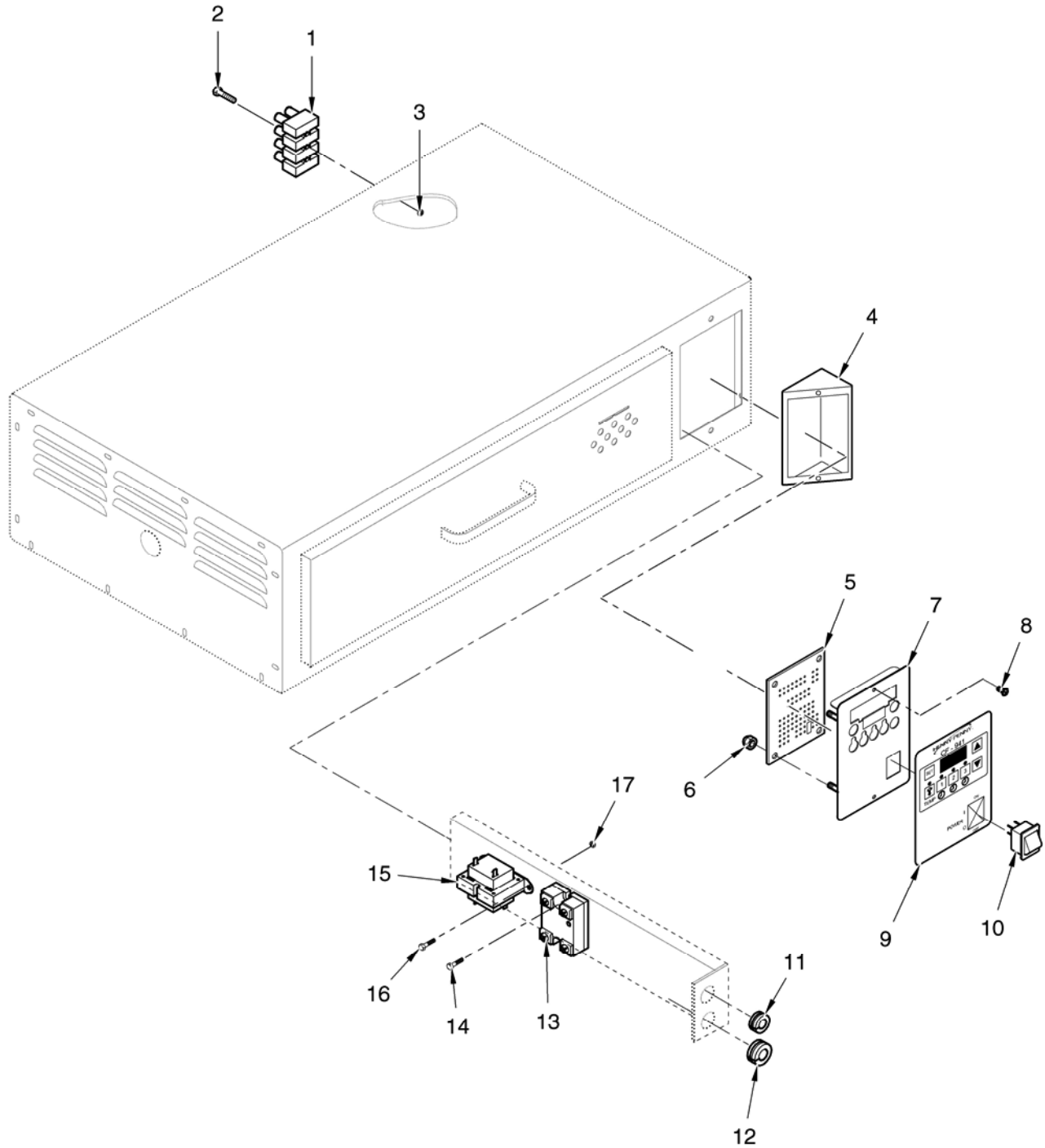

Figure 2-4. Electrical Controls

**FIG. &
ITEM**

NO.	PART NO.	DESCRIPTION	QTY 941	QTY 942	QTY 943	QTY 944
2-4		ELECTRICAL CONTROLS				
1	33073	TERMINAL BLOCK – 4 POLE	1	1	1	1
2	SC01-053	SCREW	3	3	3	3
3	NS02-007	NUT	3	3	3	3
4	51925	CONTROL BRACKET WELD ASSY.	-	-	-	1
√ 5	52755RB	PC BOARD ASSY. – GEN. MKT.	1	1	1	1
√ 5	51102	PC BOARD ASSY. – WENDY’S	1	1	1	1
6	NS02-005	NUT	4	4	4	4
7	51924	CONTROL PANEL STUD ASSY.	-	-	-	1
7	51545	CONTROL PANEL STUD ASSY.	1	2	3	-
8	SC04-003	SCREW	2	2	2	2
9	51463	DECAL - CONTROL - 941 - WENDY’S	1	-	-	-
9	52695	DECAL - CONTROL - 941 - GEN. MKT.	1	-	-	-
9	52699	DECAL - CONTROL - 941 - DAIRY QUEEN	1	-	-	-
9	51560	DECAL - CONTROL - 942 - WENDY’S	-	1	-	-
9	52696	DECAL - CONTROL - 942 - GEN. MKT.	-	1	-	-
9	51561	DECAL - CONTROL - 943 - WENDY’S	-	-	1	-
9	52697	DECAL - CONTROL - 943 - GEN. MKT.	-	-	1	-
9	51464	DECAL - CONTROL - 944 - WENDY’S	-	-	-	1
9	52698	DECAL - CONTROL - 944 - GEN. MKT.	-	-	-	1
√ 10	43768	POWER SWITCH	1	1	1	1
√ 10	52224	POWER SWITCH – CE	1	1	1	1
11	EF02-072	BUSHING - SPLIT	1	1	1	1
12	EF02-040	BUSHING - SNAP	1	1	1	1
√ 13	40645	RELAY 1	2	3	4	
14	SC04-003	SCREW	2	2	2	2
√ 15	28979	TRANSFORMER - 208/240 V.	1	1	1	1
√ 15	30978	TRANSFORMER - 120 V.	1	1	1	1
16	SC01-034	SCREW	2	2	2	2
17	NS02-007	NUT	2	2	2	2
√ 18*	51390	EMC FILTER – CE	1	1	1	1
√ 18*	FA53-005	FUSE – CE 1	1	1	1	
√ 19*	EF02-114	FUSE HOLDER	1	1	1	1

√ recommended parts
*not shown

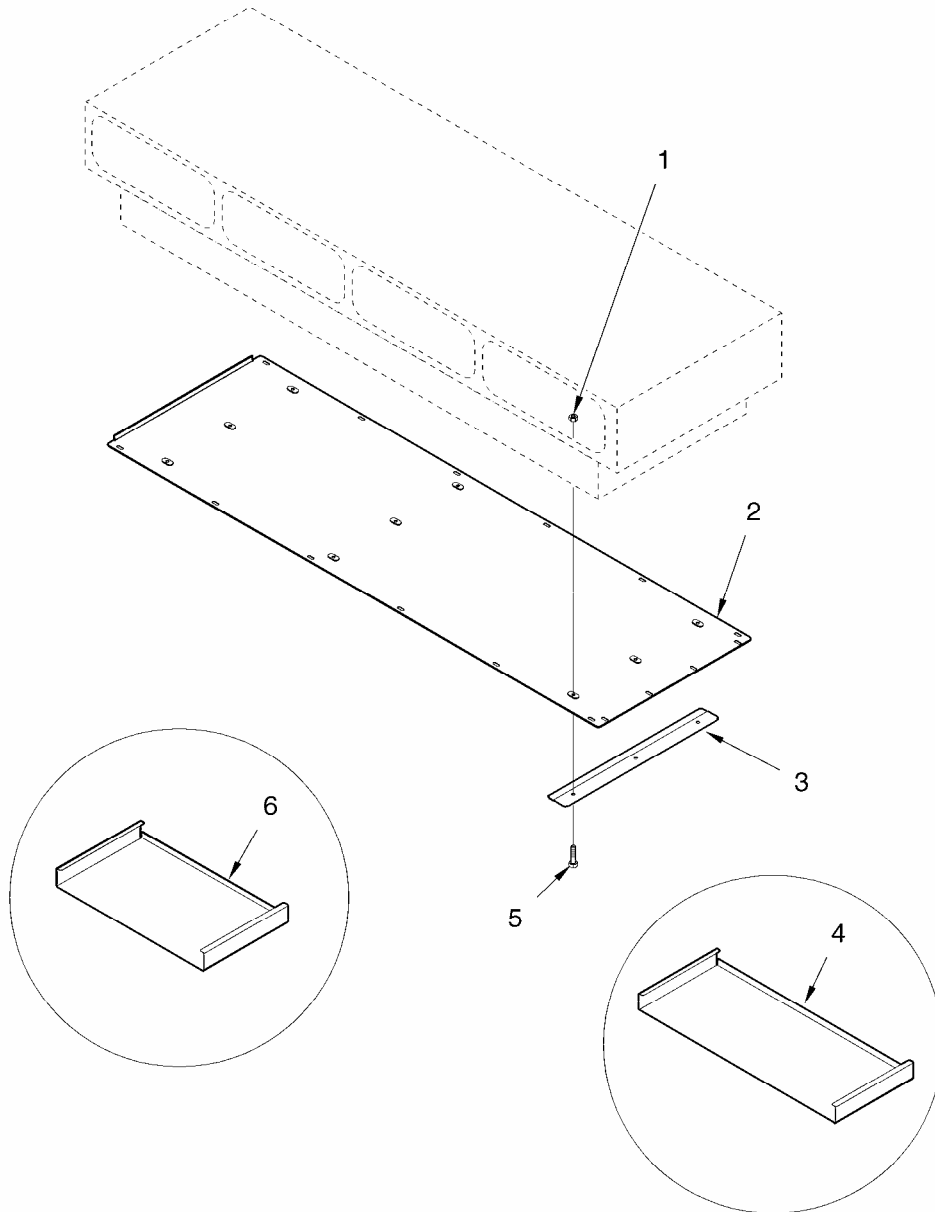

Figure 2-5. Paper Tray

FIG. & ITEM NO.	PART NO.	DESCRIPTION	QTY	QTY	QTY	QTY
			941	942	943	944
2-5		PAPER TRAY				
1	NS-02-007	NUT	-	-	-	12
2	52854	PANEL - BOTTOM ACCESS	-	-	-	1
3	52845	BRACKET – PAPER TRAY	-	-	-	4
4	05940	3 PAPER TRAY – WENDY’S	-	-	-	2
5	SC01-153	SCREW	-	-	-	12
6	05941	2 PAPER TRAY – WENDY’S	-	-	-	2