

HENNY PENNY®
Global Foodservice Solutions

Henny Penny
Multipurpose Holding Cabinet

Model CF-941

TECHNICAL MANUAL

TABLE OF CONTENTS

Section	Page
Section 1. MAINTENANCE	1-1
1-1. Introduction	1-1
1-2. Safety	1-1
1-3. Test Instruments	1-2
1-4. Error Codes.....	1-2
1-5. Control Board.....	1-3
1-6. Power Switch	1-3
1-7. Transformer	1-4
1-8. Relays	1-5
1-9. Heating Elements	1-6
1-10. Temperature Probe	1-7
1-11. Drawer Gasket.....	1-8
1-12. High Limit	1-9
1-13. Wiring Diagram.....	1-10
Section 2. PARTS INFORMATION	2-1
2-1. Introduction	2-1
2-2. Genuine Parts	2-1
2-3. How To Order Parts	2-1
2-4. Prices	2-1
2-5. Delivery	2-1
2-6. Warranty	2-1
2-7. Recommended Spare Parts for Distributors	2-1

SECTION 1. MAINTENANCE

1-1. INTRODUCTION

This section provides procedures for checking and replacement of the various parts used within the cabinet.

1-2. SAFETY

Where information is of particular importance or is safety related, the words NOTICE, CAUTION, or WARNING are used. Their usage is described below:



SAFETY ALERT SYMBOL is used with DANGER, WARNING, or CAUTION which indicates a personal injury type hazard.



NOTICE is used to highlight especially important information.



CAUTION used without the safety alert symbol indicates a potentially hazardous situation which, if not avoided, may result in property damage.



CAUTION used with the safety alert symbol indicates a potentially hazardous situation which, if not avoided, may result in minor or moderate injury.



WARNING indicates a potentially hazardous situation which, if not avoided, could result in death or serious injury.

1-3. TEST INSTRUMENTS

You may use two test instruments to check the electrical components.

1. A continuity light.
2. An ohmmeter.

When the manual refers to the circuit being closed, the continuity light will be illuminated or the ohmmeter should read zero unless otherwise noted. When the manual refers to the circuit being open, the continuity will not illuminate or the ohmmeter will read one or infinite resistance.

NOTICE

An ohmmeter must be used to check coils.

1-4. ERROR CODES

DISPLAY	CAUSE	PANEL BOARD CORRECTION
"E-4"	Control board overheating	Turn switch to OFF position, then turn switch back to ON; if display shows "E-4", the control board is getting too hot; make sure unit is not overheating
"E-6"	Faulty temperature probe	Check to see if unit is set to the correct number of drawers, ex: "MP-942=2" drawers (see Operation and Programming Section in Operator's Manual)
"E-41"	Memory scrambled	Press and release the UP and DOWN buttons to initialize the program; if "E-41" persists, replace the control board
"Hi"	Unit over-heating; faulty relay or control board	Have relay or control board replaced

1-5. CONTROL BOARD

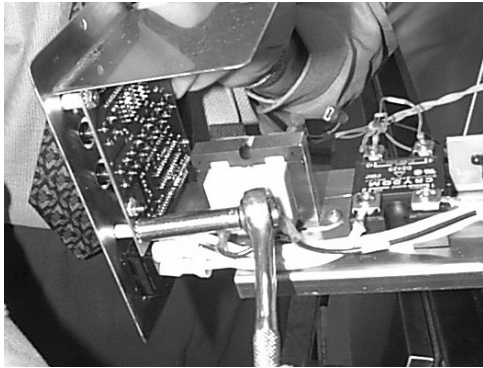

Step 3

1. Disconnect the electrical supply to the cabinet.



To avoid electrical shock or property damage, move the POWER switch to OFF and disconnect main circuit breaker, or unplug cord at wall receptacle.

2. Remove the two screws on the front of the control panel and pull control drawer out.
3. Using a 5/16" socket, remove nuts securing the board and remove board from the panel.
4. Remove the wires from the control board.
5. Install new control board in reverse order.

NOTICE

Do not over-tighten nuts securing the control board, or the buttons on the controls may not function.

1-6. POWER SWITCH

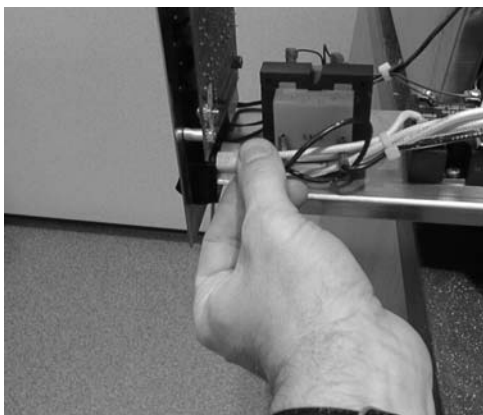

Step 3

1. Disconnect the electrical supply to the cabinet.



To avoid electrical shock or property damage, move the POWER switch to OFF and disconnect main circuit breaker, or unplug cord at wall receptacle.

2. Remove the two screws on the front of the control panel and pull control drawer out.

NOTICE

Mark the wires when removing them from the switch to be sure the switch is rewired correctly.

3. Remove the wires from the switch. Check for continuity across the top and bottom terminals, on both left and right side of the switch. With the switch in the ON position, the circuit should be closed. With the switch in the OFF position, the circuit should be open. If the switch is defective, replace it by continuing with this section.

1-6. POWER SWITCH (Continued)

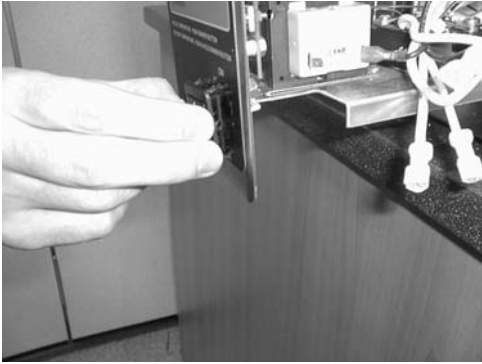

Step 4

4. Squeeze the tabs on the back of the switch and pull the switch out from the front of the panel.
5. Install new switch in reverse order.

1-7. TRANSFORMER



Step 3

1. Disconnect the electrical supply to the cabinet.



To avoid electrical shock or property damage, move the POWER switch to OFF and disconnect main circuit breaker, or unplug cord at wall receptacle.

2. Remove the two screws on the front of the control panel and pull control drawer out.
3. Label wires and remove them from the transformer.
4. Using a Phillips head screwdriver, remove the two screws securing the transformer and remove the transformer.
5. Install the new transformer in reverse order.

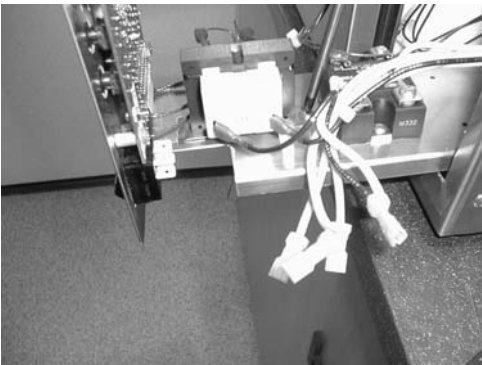

Step 5

1-8. RELAYS

1. Disconnect the electrical supply to the cabinet.



To avoid electrical shock or property damage, move the POWER switch to OFF and disconnect main circuit breaker, or unplug cord at wall receptacle.

2. Remove the two screws on the front of the control panel and pull control panel out.

Checkout:

3. With no power going to the relay, 120 volts should show on the output side of the relay, and 0 volts on the input.



To avoid electrical shock, make connections before applying power, take reading, and remove power before removing meter leads. The following checks are performed with the wall circuit breaker closed and the POWER switch in the ON position.

4. With the component energized, 0 volts should show on the output side of the relay, and 5 volts on the input side.
5. If voltage varies from steps 3 and 4, remove power to unit, pull input wires from relay and place leads of meter onto input wires. Reapply power to unit. When unit is running, the input wires to relay should show 5 vdc. If this proves true, the relay is faulty.

1-8. RELAYS (Continued)



Step 8

Replacement:

6. Remove power supplied to unit.
7. Label and remove wires from the appropriate relay.
8. Using a Phillips head screwdriver, remove the screws securing the relay and remove the relay from the unit.
9. Coat the back of the relay with the thermal joint compound and install new relay.

CAUTION

Failure to use the thermal joint compound will shorten the life of the relay.

10. Replace control panel and unit is now ready for use.

1-9. HEATING ELEMENTS

1. Disconnect the electrical supply to the cabinet.



To avoid electrical shock or property damage, move the POWER switch to OFF and disconnect main circuit breaker, or unplug cord at wall receptacle.

2. Remove the drawer from the liner.
3. Using a 3/8" socket, remove the 4 acorn nuts securing the front of the bracket.
4. Using a Phillips head screwdriver, remove the ten screws securing the bracket and remove the bracket.



Step 4

1-9. HEATING ELEMENTS
(Continued)



Step 5

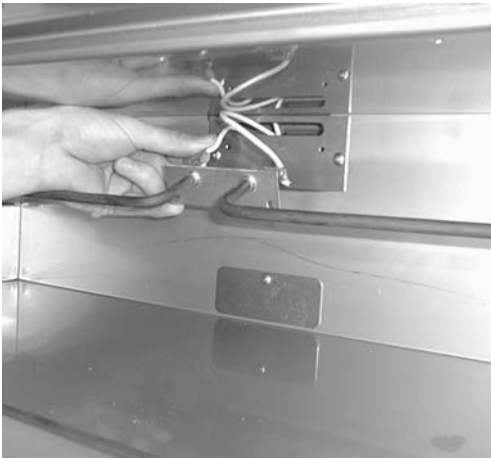

Step 7

5. Using a Phillips head screwdriver, remove the two screws securing the element to the back of the liner.
6. Pull the element out towards you until the terminals are exposed.
7. Pull the wires off of the terminals and remove element from the unit.
8. Install new element in reverse order.

1-10. TEMPERATURE PROBE

1. Disconnect the electrical supply to the cabinet.



To avoid electrical shock or property damage, move the POWER switch to OFF and disconnect main circuit breaker, or unplug cord at wall receptacle.

2. Remove the drawer.

1-10. TEMPERATURE PROBE (Continued)



Step 3



Step 5

3. Using a flat blade screwdriver, pry the rubber strain relief from the liner.
4. Pull the probe wires out of the unit, far enough to access the connector, incased in a protective cover.
5. Cut the wire ties on the ends of the cover and slide the protective cover up and out of the way.
6. Disconnect the wires at the connector.
7. Reconnect the new temperature probe assembly to the unit and pull protective cover back over the connector, then secure with wire ties.
8. Thread the wire back through the hole and push the strain relief back into the liner.
9. Place drawer back into unit and the unit is now ready for use.

1-11. DRAWER GASKET



Step 2

1. Remove the drawer from the unit.
2. Using a Phillips-head screwdriver, remove the drawer handle by removing the two screws fastening the handle to the drawer.

1-11. DRAWER GASKET
(Continued)

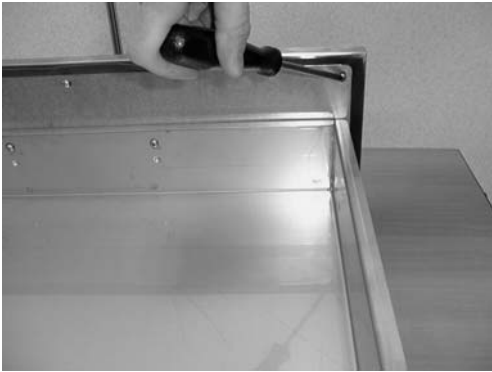

Step 3

3. Using a Phillips head screwdriver, remove the six screws that secure the backing plate and gasket to the drawer front.
4. Separate the drawer frame from the drawer front.
5. Remove the gasket from the drawer front.
6. Reassemble the drawer frame and drawer front in reverse order of disassembly. Make sure the two drawer handle spacers between the drawer front and backing plate remain centered over the holes so that the handle screws will pass through the spacers.

1-12. HIGH LIMIT



Step 4



Step 7

1. Disconnect the electrical supply to the cabinet.



To avoid electrical shock or property damage, move the POWER switch to OFF and disconnect main circuit breaker, or unplug cord at wall receptacle.

2. Remove the drawer from the liner.
3. Using a Phillips head screwdriver, remove the ten screws securing the bracket and remove the bracket. (See photos in section 1-9.)
4. Using a Phillips head screwdriver, remove the two screws securing the plate to the back of the liner.
5. Pull the element out towards you until the terminals are exposed.
6. Label and pull the wires off of the element terminals and high limit.
7. Using a 5/16" socket, remove the nuts securing the high limit and remove the high limit from the unit.
8. Install new high limit in reverse order.

1-13. WIRING DIAGRAM

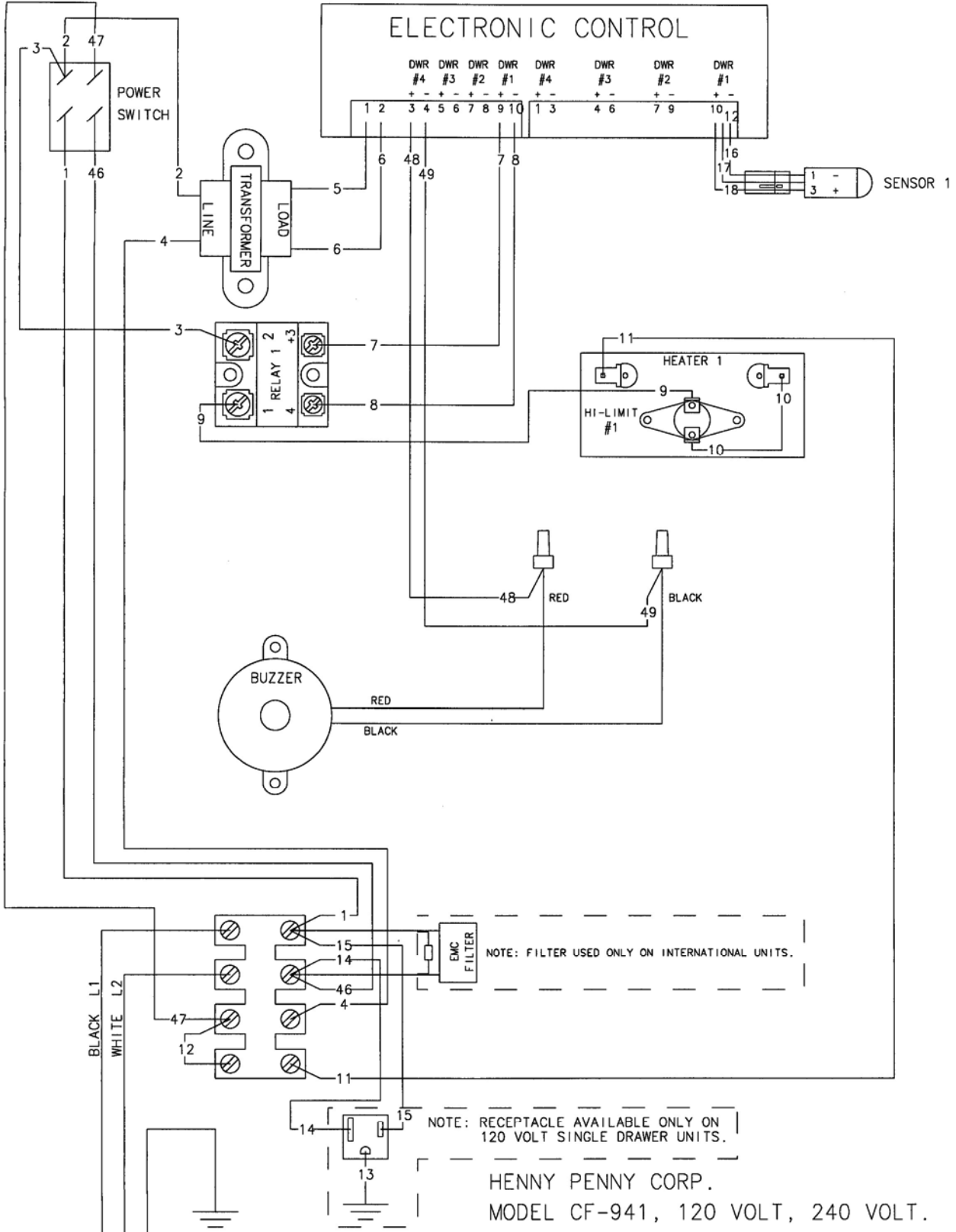

LIMITED WARRANTY FOR HENNY PENNY EQUIPMENT

Subject to the following conditions, Henny Penny Corporation makes the following limited warranties to the original purchaser only for Henny Penny appliances and replacement parts:

NEW EQUIPMENT: Any part of a new appliance, except baskets, lamps, and fuses, which proves to be defective in material or workmanship within two (2) years from date of original installation, will be repaired or replaced without charge F.O.B. factory, Eaton, Ohio, or F.O.B. authorized distributor. Baskets will be repaired or replaced for ninety (90) days from date of original installation. Lamps and fuses are not covered under this Limited Warranty. To validate this warranty, the registration card for the appliance must be mailed to Henny Penny within ten (10) days after installation.

FILTER SYSTEM: Failure of any parts within a fryer filter system caused by the use of the non-OEM filters or other unapproved filters is not covered under this Limited Warranty.

REPLACEMENT PARTS: Any appliance replacement part, except lamps and fuses, which proves to be defective in material or workmanship within ninety (90) days from date of original installation will be repaired or replaced without charge F.O.B. factory, Eaton, Ohio, or F.O.B. authorized distributor.

The warranty for new equipment covers the repair or replacement of the defective part and includes labor charges and maximum mileage charges of 200 miles round trip for a period of one (1) year from the date of original installation.

The warranty for replacement parts covers only the repair or replacement of the defective part and does not include any labor charges for the removal and installation of any parts, travel, or other expenses incidental to the repair or replacement of a part.

EXTENDED FRYPOT WARRANTY: Henny Penny will replace any frypot that fails due to manufacturing or workmanship issues for a period of up to seven (7) years from date of manufacture. This warranty shall not cover any frypot that fails due to any misuse or abuse, such as heating of the frypot without shortening.

0 TO 3 YEARS: During this time, any frypot that fails due to manufacturing or workmanship issues will be replaced at no charge for parts, labor, or freight. Henny Penny will either install a new frypot at no cost or provide a new or reconditioned replacement fryer at no cost.

3 TO 7 YEARS: During this time, any frypot that fails due to manufacturing or workmanship issues will be replaced at no charge for the frypot only. Any freight charges and labor costs to install the new frypot as well as the cost of any other parts replaced, such as insulation, thermal sensors, high limits, fittings, and hardware, will be the responsibility of the owner.

Any claim must be presented to either Henny Penny or the distributor from whom the appliance was purchased. No allowance will be granted for repairs made by anyone else without Henny Penny's written consent. If damage occurs during shipping, notify the sender at once so that a claim may be filed.

THE ABOVE LIMITED WARRANTY SETS FORTH THE SOLE REMEDY AGAINST HENNY PENNY FOR ANY BREACH OF WARRANTY OR OTHER TERM. BUYER AGREES THAT NO OTHER REMEDY (INCLUDING CLAIMS FOR ANY INCIDENTAL OR CONSEQUENTIAL DAMAGES) SHALL BE AVAILABLE.

The above limited warranty does not apply (a) to damage resulting from accident, alteration, misuse, or abuse; (b) if the equipment's serial number is removed or defaced; or (c) for lamps and fuses. THE ABOVE LIMITED WARRANTY IS EXPRESSLY IN LIEU OF ALL OTHER WARRANTIES, EXPRESS OR IMPLIED, INCLUDING MERCHANTABILITY AND FITNESS, AND ALL OTHER WARRANTIES ARE EXCLUDED. HENNY PENNY NEITHER ASSUMES NOR AUTHORIZES ANY PERSON TO ASSUME FOR IT ANY OTHER OBLIGATION OR LIABILITY.

Revised 01/01/07

SECTION 2. PARTS INFORMATION

2-1. INTRODUCTION

This section identifies and lists the replaceable parts of the Henny Penny Multipurpose Holding Cabinets.

2-2. GENUINE PARTS

Use only genuine Henny Penny parts in your cabinet. Using a part of lesser quality or substitute design may result in cabinet damage or personal injury.

2-3. HOW TO ORDER

Once the part you want to order has been found in the Parts

List, write down the following information:

1. From the Parts List:

(Sample)

Item Number	<u>1</u>
Part Number	<u>51718</u>
Description	<u>Gasket – Drawer</u>

2. From the data plate:

(Sample)

Product Number	<u>05882</u>
Serial Number	<u>0001</u>
Voltage	<u>120V</u>

2-4. PRICES

Your independent Henny Penny distributor has a price parts list and will be glad to inform you of the cost of your parts order.

2-5. DELIVERY

Commonly replaced items are stocked by your independent Henny Penny distributor and will be sent out when your order is received. Other parts will be ordered by the distributor from Henny Penny Corporation. Normally, these will be sent to your distributor within three working days.

2-6. WARRANTY

All replacement parts (except lamps and fuses) are covered under warranty for 90 days against manufacturing defects and workmanship. If damage occurs during shipping, notify the carrier at once so that a claim may be properly filed. Refer to warranty on the front of this section for other rights and limitations.

2.7. RECOMMENDED SPARE PARTS FOR DISTRIBUTORS

Recommended replacement parts, stocked by your distributor, are indicated with √ in the parts lists. Please use care when ordering recommended parts, because all voltages and variations are marked. Distributors should order parts based upon common voltages and equipment sold in their territory.

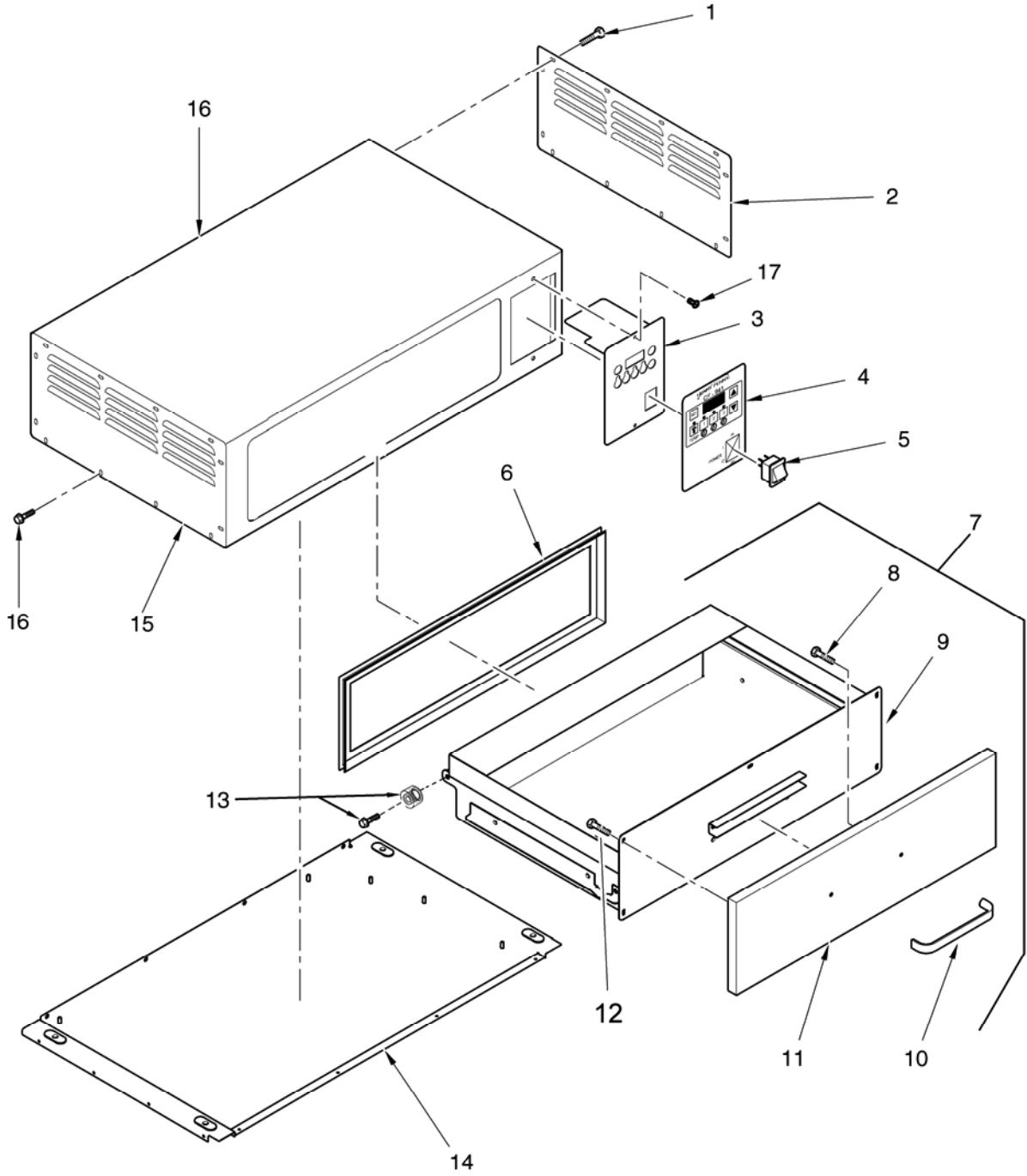

Figure 2-1. Drawer and Shell

FIG. & ITEM NO.	PART NO.	DESCRIPTION	Qty.
2-1		DRAWER AND SHELL	
1	SC01-034	SCREW	10
2	54432	PANEL - RH ACCESS	1
3	51545	CONTROL PANEL STUD ASSY.	1
4	51562	DECAL - CONTROL	1
√ 5	43768	POWER SWITCH	1
√ 6	51718	GASKET - DRAWER	1
7	52668	DRAWER ASSY.- NO VENT	1
8	SC01-144	. SCREW	2
9	52670	. WELD ASSY - DRAWER	1
10	31395	. DRAWER HANDLE	1
11	14716	. KIT - DRAWER FRONT	1
12	SC01-074 SCREW - #10-32 X ½ PH THD S	5
√ 13	14113	. BEARING KIT	1
14	52645	BASE ASSY.	1
15	54434	PANEL - ACCESS - LH	1
16	SC01-034	SCREW	10
17	52654	SHELL ASSY.	1
18*	52658	INSULATION - LINER - REAR - UPPER	1
19*	52659	INSULATION - LINER BOTTOM	1
20*	52660	INSULATION - SHELL - TOP	1
21*	53661	INSULATION - LEFT SIDE	1
22*	63835	INSULATION - LINER SIDE	1
23*	52663	INSULATION - RIGHT SIDE	1
24*	51471	INSULATION - LINER - REAR - LOWER	1
25*	51474	INSULATION - LINER - TOP	1
26*	52093	INSULATION - TOP - LINER - FRONT	1

√ recommended parts
 *not shown

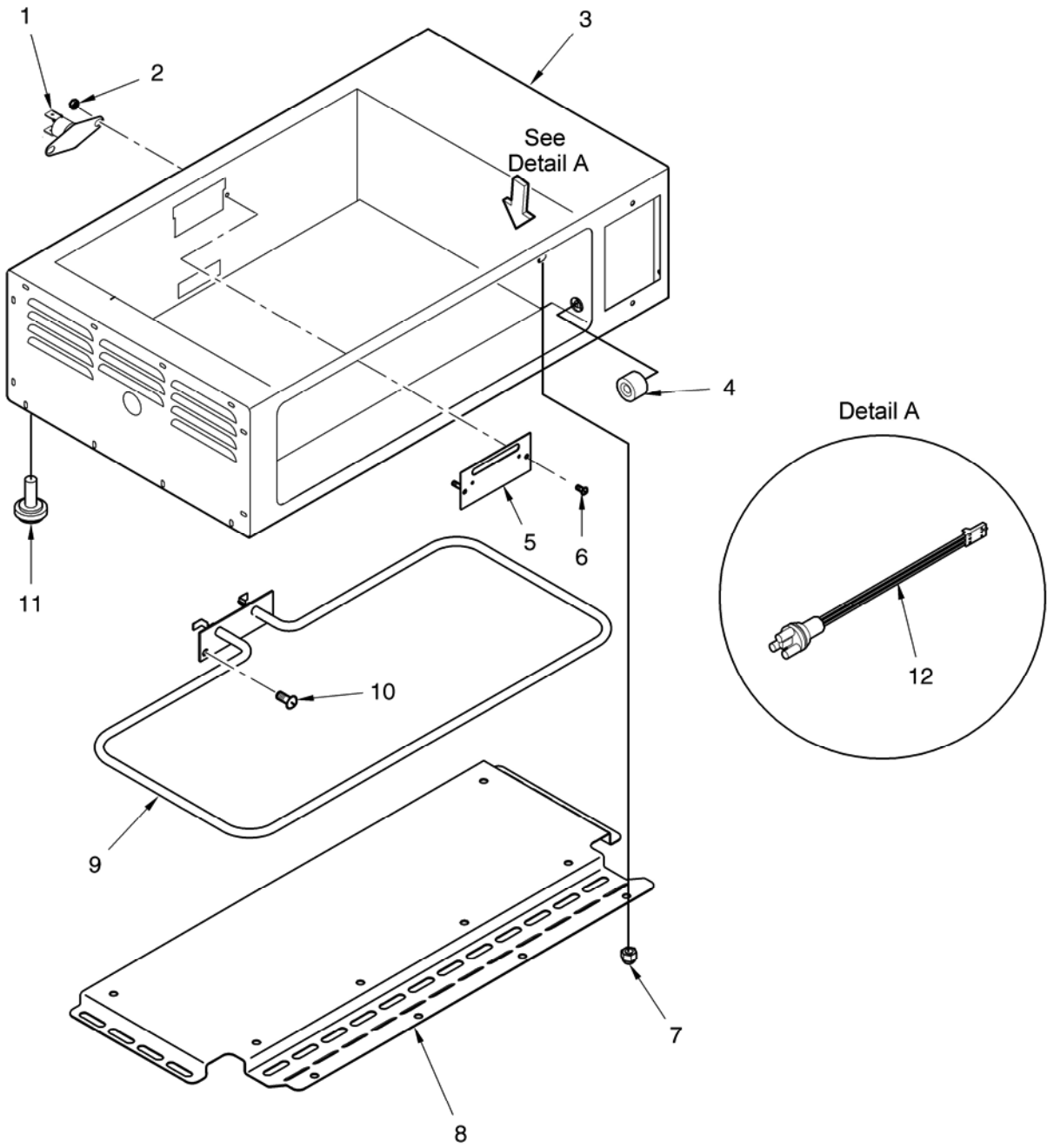

Figure 2-2. Heater and High Limit

FIG. & ITEM NO.	PART NO.	DESCRIPTION	Qty.
2-2		HEATER AND HIGH LIMIT	
√ 1	18201	HIGH LIMIT - 335° F (BEHIND HEATER PLATE)	1
2	NS02-005	NUT	2
3	54583	LINER WELD ASSY.	1
√ 4	14113	BEARING KIT	1
5	51951	BRACKET – HEATER (BEFORE SN: GA0407031)	1
6	SC01-034	SCREW	2
7	NS03-024	ACORN NUT	3
8	54465	DEFLECTOR – HEAT (BEFORE APRIL 1, 2001)	1
8	71001	DEFLECTOR – HEAT (APRIL 1, 2001 & AFTER)	1
√ 9	51796	HEATER - 475 W. - 120 V.	1
10	SC02-041	SCREW	2
11	26411	FOOT	4
√ 12	52100	TEMPERATURE SENSOR ASSY.	1
13*	NS02-002	NUT	4
14*	05031	1/3 SIZE PAN	2
15*	05208	1/6 SIZE PAN	2
16*	44341	PAN INSERT - 1/3 SIZE	2
17*	48001	PAN INSERT - 1/6 SIZE	2

√ recommended parts

*not shown

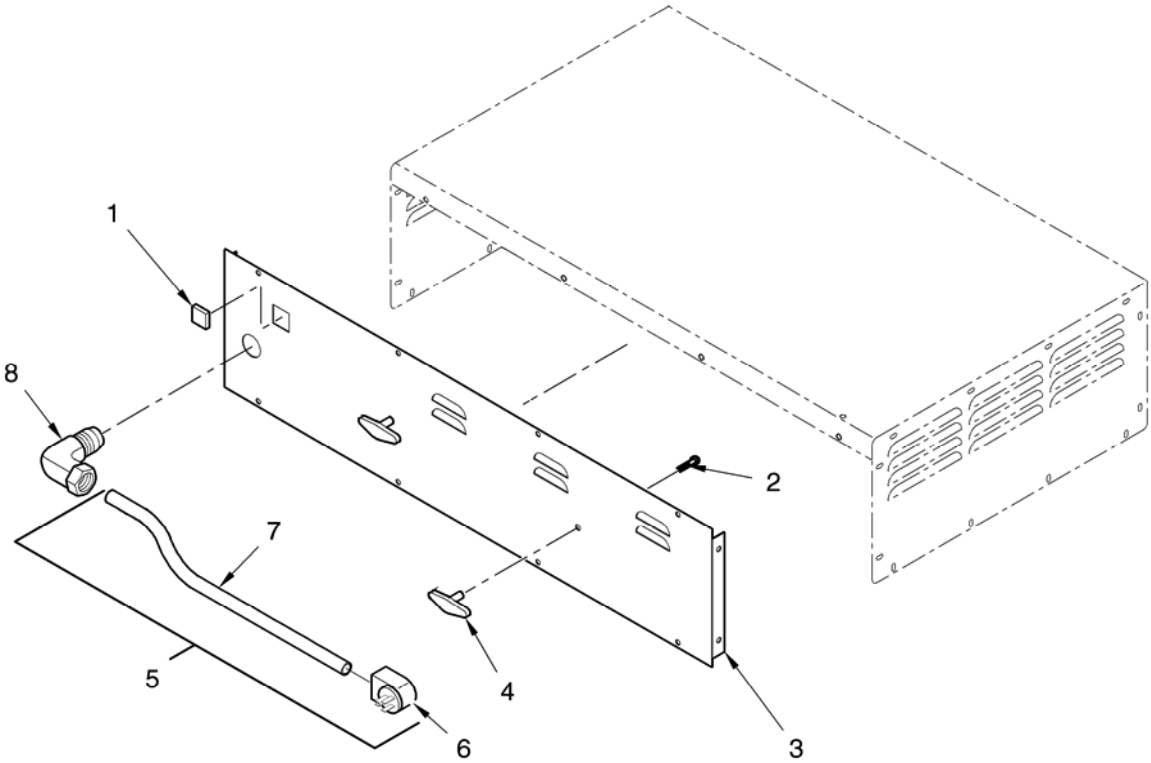

Figure 2-3. Rear Panel

FIG. & ITEM NO.	PART NO.	DESCRIPTION	Qty.
2-3		REAR PANEL	
1	MS01-197	RECEPTACLE - NEMA 5-15 R	1
2	SC01-172	SCREW	2
3	54443	PANEL - REAR ACCESS	1
4	27645	KNOB, CORD WRAP	2
5	54502	POWER CORD ASSY.	1
6	40298	. PLUG - ANGLED - 125 V.- 15 AMP	1
7	54501	. POWER CORD	1
8	27639	STRAIN RELIEF	1

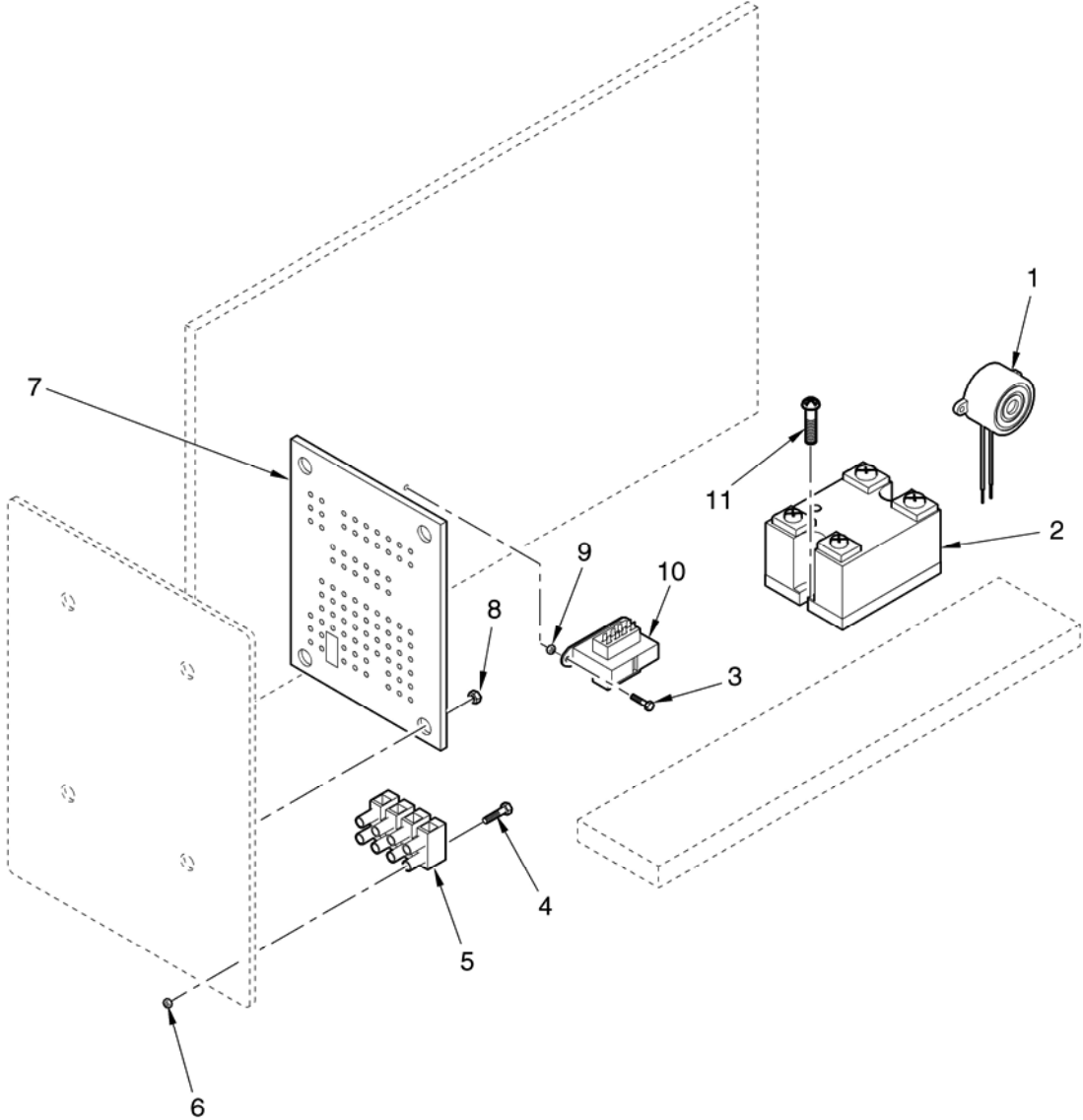

Figure 2-4. Electrical Parts

FIG. & ITEM NO.	PART NO.	DESCRIPTION	Qty.
2-4		ELECTRICAL PARTS	
√ 1	52664	BUZZER	1
√ 2	40645	RELAY	1
3	SC01-034	SCREW	2
4	SC01-053	SCREW	3
5	32871	TERMINAL BLOCK	1
6	NS02-007	NUT	3
√ 7	51103RB	PC BOARD 1	
8	NS02-005	NUT	4
9	NS02-007	NUT	2
√ 10	30978	TRANSFORMER - 12VAC	1
11	SC04-003	SCREW	2

√ recommended parts
 *not shown

