



Henny Penny Express Profit Center

Model EPC-2
Model EPC-3
Model EPC-4

(Translated Documents Available On CD within Manual)

OPERATOR'S MANUAL

REGISTER WARRANTY ONLINE AT WWW.HENNYPENNY.COM

LIMITED WARRANTY FOR HENNY PENNY EQUIPMENT

Subject to the following conditions, Henny Penny Corporation makes the following limited warranties to the original purchaser only for Henny Penny appliances and replacement parts:

NEW EQUIPMENT: Any part of a new appliance, except baskets, lamps, and fuses, which proves to be defective in material or workmanship within two (2) years from date of original installation, will be repaired or replaced without charge F.O.B. factory, Eaton, Ohio, or F.O.B. authorized distributor. Baskets will be repaired or replaced for ninety (90) days from date of original installation. Lamps and fuses are not covered under this Limited Warranty. To validate this warranty, the registration card for the appliance must be mailed to Henny Penny within ten (10) days after installation.

FILTER SYSTEM: Failure of any parts within a fryer filter system caused by the use of the non-OEM filters or other unapproved filters is not covered under this Limited Warranty.

REPLACEMENT PARTS: Any appliance replacement part, except lamps and fuses, which proves to be defective in material or workmanship within ninety (90) days from date of original installation will be repaired or replaced without charge F.O.B. factory, Eaton, Ohio, or F.O.B. authorized distributor.

The warranty for new equipment covers the repair or replacement of the defective part and includes labor charges and maximum mileage charges of 200 miles round trip for a period of one (1) year from the date of original installation.

The warranty for replacement parts covers only the repair or replacement of the defective part and does not include any labor charges for the removal and installation of any parts, travel, or other expenses incidental to the repair or replacement of a part.

EXTENDED FRYPOT WARRANTY: Henny Penny will replace any frypot that fails due to manufacturing or workmanship issues for a period of up to seven (7) years from date of manufacture. This warranty shall not cover any frypot that fails due to any misuse or abuse, such as heating of the frypot without shortening.

0 TO 3 YEARS: During this time, any frypot that fails due to manufacturing or workmanship issues will be replaced at no charge for parts, labor, or freight. Henny Penny will either install a new frypot at no cost or provide a new or reconditioned replacement fryer at no cost.

3 TO 7 YEARS: During this time, any frypot that fails due to manufacturing or workmanship issues will be replaced at no charge for the frypot only. Any freight charges and labor costs to install the new frypot as well as the cost of any other parts replaced, such as insulation, thermal sensors, high limits, fittings, and hardware, will be the responsibility of the owner.

Any claim must be presented to either Henny Penny or the distributor from whom the appliance was purchased. No allowance will be granted for repairs made by anyone else without Henny Penny's written consent. If damage occurs during shipping, notify the sender at once so that a claim may be filed.

THE ABOVE LIMITED WARRANTY SETS FORTH THE SOLE REMEDY AGAINST HENNY PENNY FOR ANY BREACH OF WARRANTY OR OTHER TERM. BUYER AGREES THAT NO OTHER REMEDY (INCLUDING CLAIMS FOR ANY INCIDENTAL OR CONSEQUENTIAL DAMAGES) SHALL BE AVAILABLE.

The above limited warranty does not apply (a) to damage resulting from accident, alteration, misuse, or abuse; (b) if the equipment's serial number is removed or defaced; or (c) for lamps and fuses. THE ABOVE LIMITED WARRANTY IS EXPRESSLY IN LIEU OF ALL OTHER WARRANTIES, EXPRESS OR IMPLIED, INCLUDING MERCHANTABILITY AND FITNESS, AND ALL OTHER WARRANTIES ARE EXCLUDED. HENNY PENNY NEITHER ASSUMES NOR AUTHORIZES ANY PERSON TO ASSUME FOR IT ANY OTHER OBLIGATION OR LIABILITY.

Revised 01/01/07

TABLE OF CONTENTS

Section		Page
Section 1.	INTRODUCTION	
	1-1. Heated Express Cabinet	1-1
	1-2. Features	1-1
	1-3. Proper Care	1-2
	1-4. Assistance	1-2
	1-5. Safety	1-2
Section 2.	INSTALLATION	
	2-1. Introduction	2-1
	2-2. Unpacking	2-1
	2-3. Location	2-2
	2-4. Cabinet Dimensions	2-3
	2-5. Electrical Connection	2-6
Section 3.	OPERATION	
	3-1. Introduction	3-1
	3-2. Operating Controls	3-1
	3-3. Start-Up	3-3
	3-4. Operation with Product	3-4
	3-5. Cleaning Procedures	3-4
	3-6. Special Program Mode	3-6
Section 4.	TROUBLESHOOTING	
	4-1. Troubleshooting Guide	4-1
	4-2. Error Codes	4-1
	GLOSSARY	G-1
	Distributor Lists - Domestic and International	

SECTION 1. INTRODUCTION

1-1. HEATED EXPRESS CABINET

The Henny Penny heated express cabinet is a basic unit of food processing equipment designed to hold hot packaged foods at proper temperature in commercial food operations. This cabinet maintains the quality of the hot foods while keeping a stable temperature.

NOTICE

As of August 16, 2005, the Waste Electrical and Electronic Equipment directive went into effect for the European Union. Our products have been evaluated to the WEEE directive. We have also reviewed our products to determine if they comply with the Restriction of Hazardous Substances directive (RoHS) and have redesigned our products as needed in order to comply. To continue compliance with these directives, this unit must not be disposed as unsorted municipal waste. For proper disposal, please contact your nearest Henny Penny distributor.



1-2. FEATURES

- Easily cleaned
- Electronically controlled temperature
- Lift-off shelves
- Easy access to electrical components
- Stainless steel construction
- LED lighting
- The EPC-3 & EPC-4 available as short, in-line units, or tall free-standing units

1-3. PROPER CARE

As in any unit of food service equipment, the Henny Penny heated express cabinet does require care and maintenance. Requirements for the maintenance and cleaning are contained in this manual and must become a regular part of the operation of the unit at all times.

1-4. ASSISTANCE

Should you require outside assistance, just call your local independent Henny Penny distributor in your area, or call Henny Penny Corp. 1-800-417-8405 toll free or 1-937-456-8405.

1-5. SAFETY

The only way to insure safe operation of the Henny Penny heated express cabinet is to fully understand the proper installation, operation, and maintenance procedures. The instructions in this manual have been prepared to aid you in learning the proper procedures. Where information is of particular importance or is safety related, the words NOTICE, CAUTION, or WARNING are used. Their usage is described below.



SAFETY ALERT SYMBOL is used with DANGER, WARNING, or CAUTION which indicates a personal injury type hazard.



NOTICE is used to highlight especially important information.



CAUTION used without the safety alert symbol indicates a potentially hazardous situation which, if not avoided, may result in property damage.



CAUTION used with the safety alert symbol indicates a potentially hazardous situation which, if not avoided, may result in minor or moderate injury.



WARNING indicates a potentially hazardous situation which, if not avoided, could result in death or serious injury.

SECTION 2. INSTALLATION

2-1. INTRODUCTION

This section provides the installation instructions for the Henny Penny heated express cabinet.

NOTICE

Installation of this unit should be performed only by a qualified service technician.



Do not puncture the skin of the unit with drills or screws as component damage or electrical shock could result.

2-2. UNPACKING

The Henny Penny heated express cabinet has been tested, inspected, and expertly packed to insure arrival at its destination in the best possible condition. The unit has been bolted to wooden skid. All items have been packed and taped inside of the unit. The unit is then packed inside a triple wall corrugated carton with sufficient padding to withstand normal shipping treatment.

NOTICE

Any shipping damages should be noted in the presence of the delivery agent and signed prior to his or her departure.

To remove the Henny Penny cabinet from the carton, you should:

1. Carefully cut banding straps.
2. Open flaps of carton and remove packing.
3. Remove carton from unit.
4. Remove unit from packaging.

2-2. UNPACKING
(Continued)

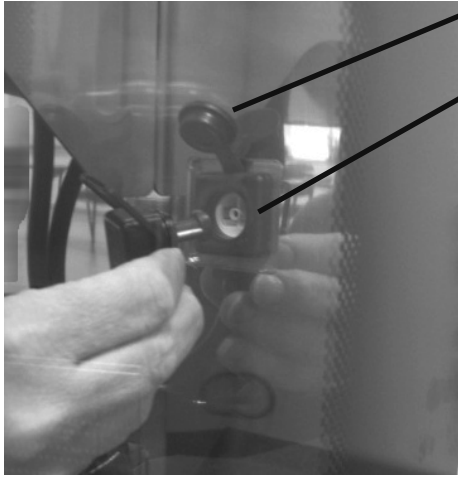

Figure 1

5. Unpack and install shelves.
 - a. Hook the shelf brackets in the slots in the back, interior of unit.
 - b. Pull the cover off the receptacles on the right side of the shelves. Figure 1.
 - c. Line up the prongs on the plug with the holes in the receptacle, and firmly push the plugs into the receptacle. Figure 1.

NOTICE

The plugs must fit firmly into the receptacles for the shelf heaters to operate.

6. Remove the bottom inserts and pull cardboard packing from around elements in bottom of unit.



To avoid fire, remove the 3 corrugated shipping supports located beneath these inserts, all visible packing material, tape, and the unpacking instructions, prior to operation.

7. Peel off any protective covering from the exterior of the cabinet.



Take care when moving the cabinet to prevent personal injury.

8. Once the shelves are installed, and the packing material removed, the unit is ready for operation.

2-3. LOCATION

The unit should be placed in an area where the unit can be loaded and unloaded easily. For proper operation, the cabinet must be level.

If the Henny Penny heated express cabinet does not have casters, level the unit and run a bead of silicone rubber (silicone or equivalent sealant must be a NSF listed material) around the perimeter of the unit, sealing it to the floor.

2-4. CABINET DIMENSIONS

EPC-2

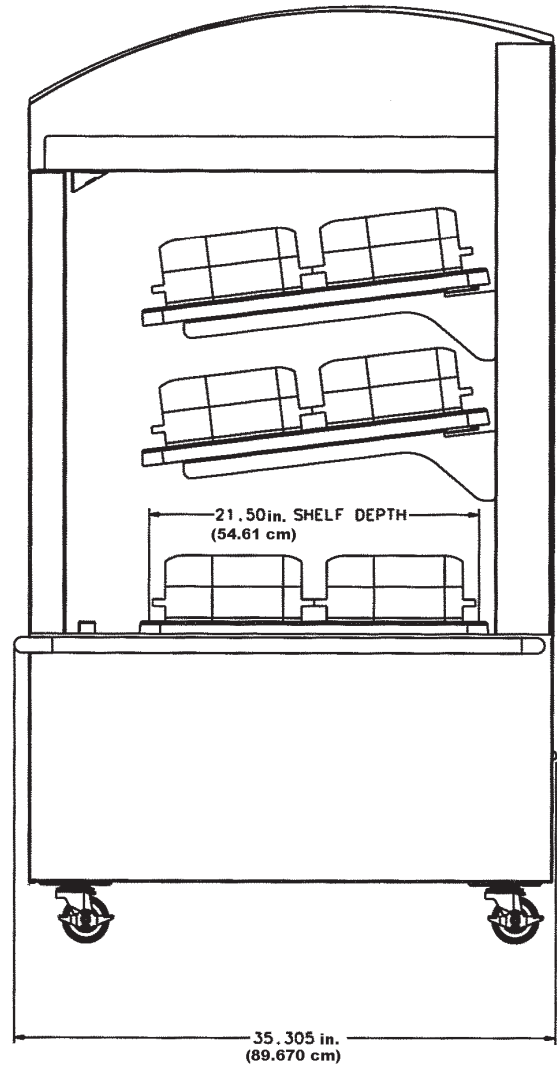
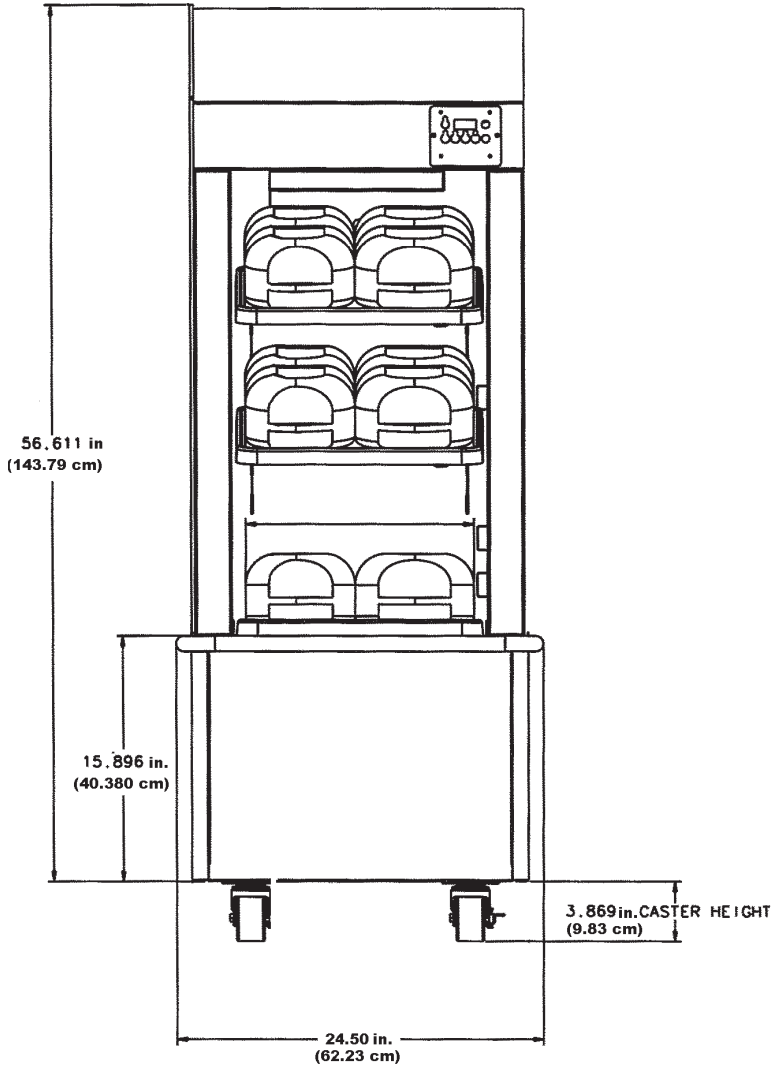

2-4. CABINET DIMENSIONS (Continued)

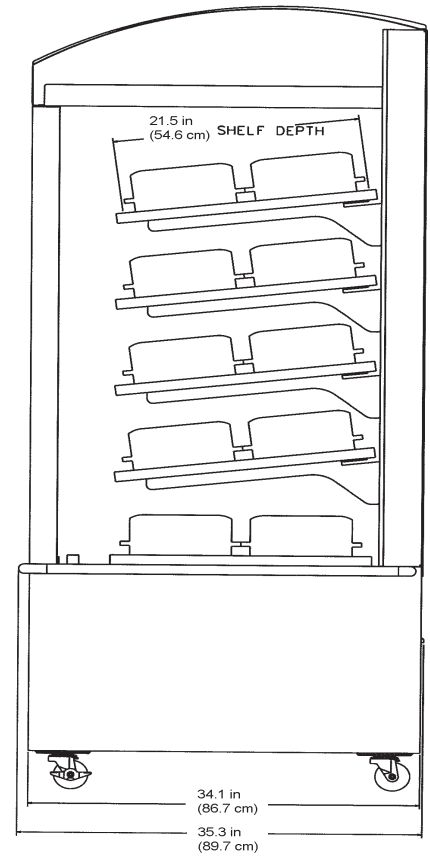
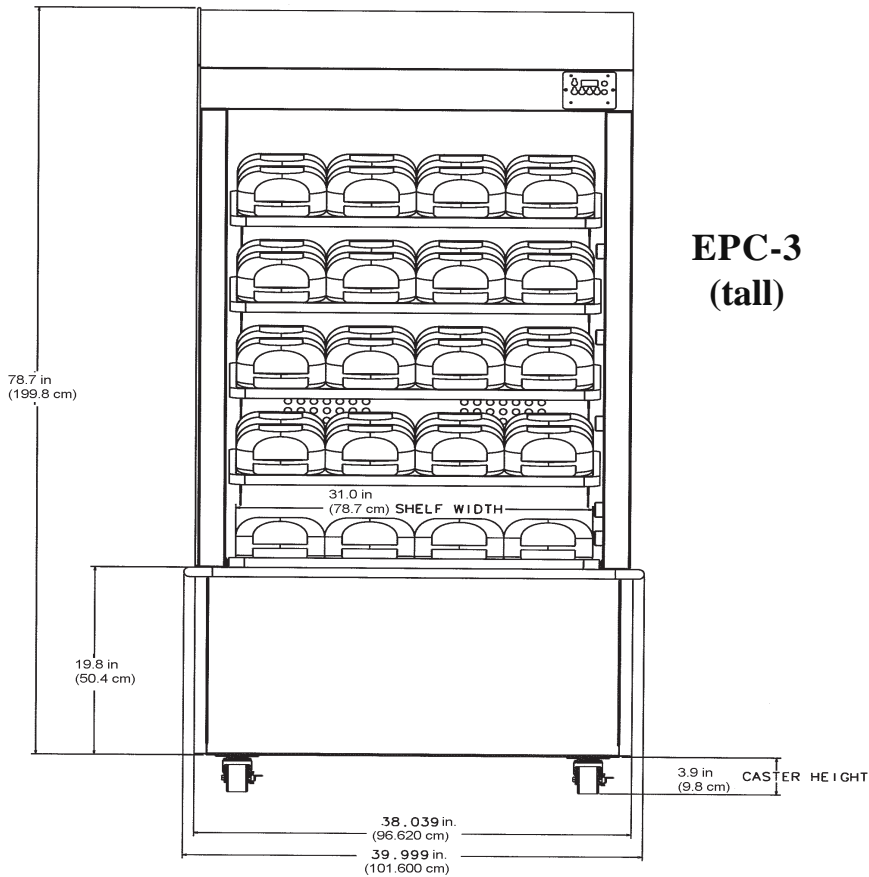
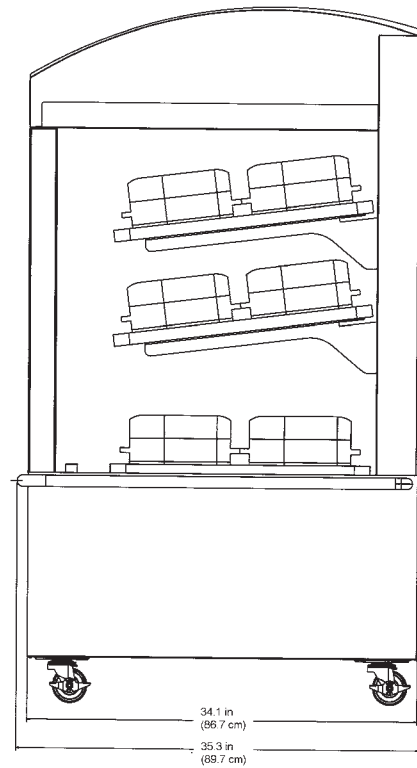
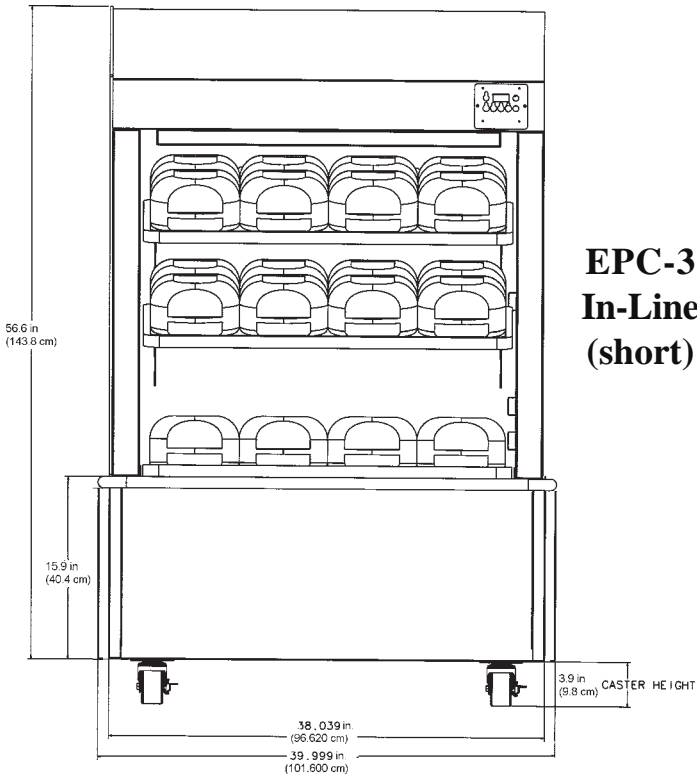

2-4. CABINET DIMENSIONS (Continued)

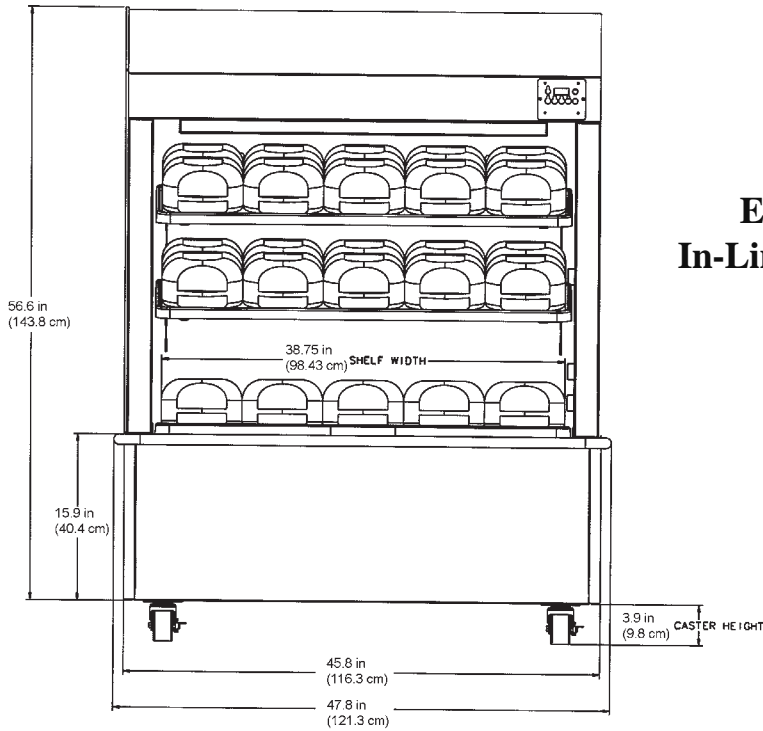

**EPC-4
In-Line (short)**

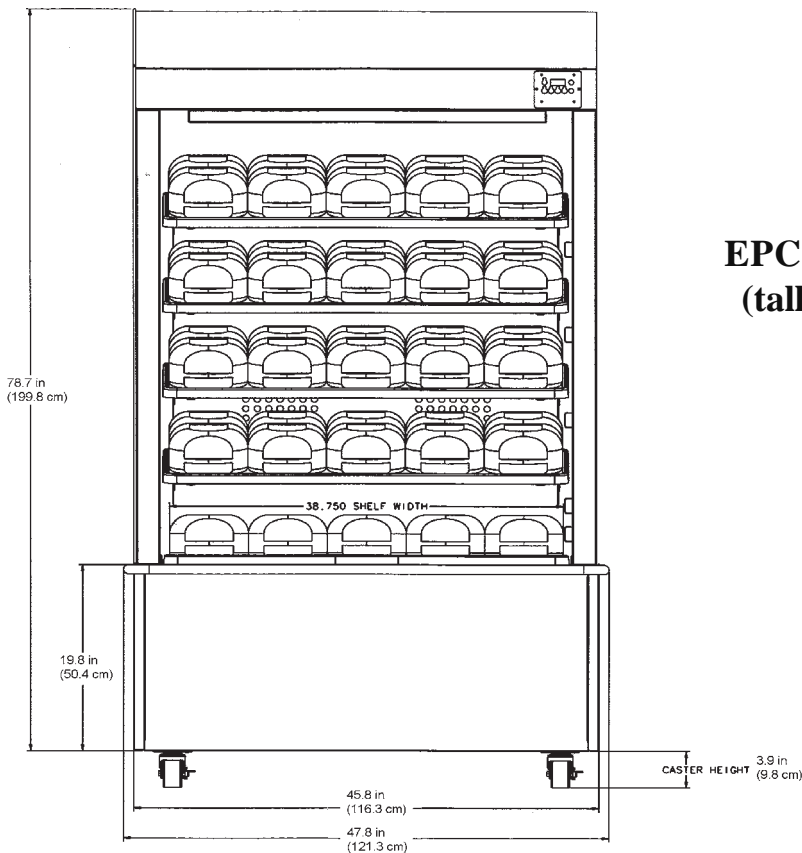
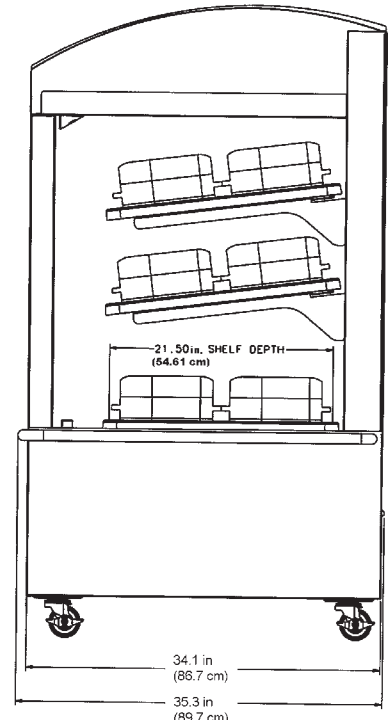

**EPC-4
(tall)**

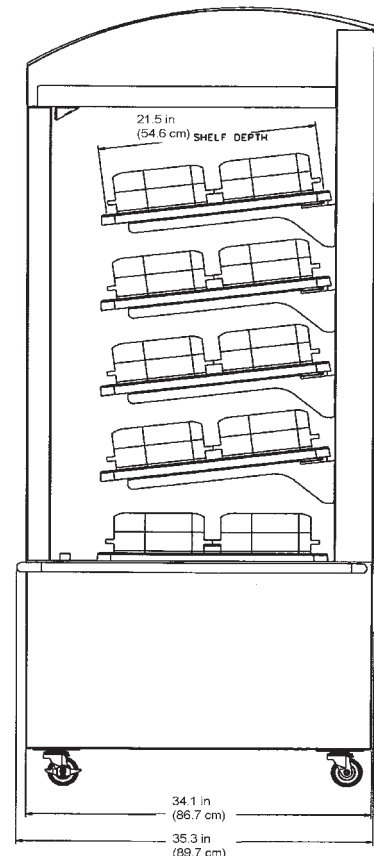

2-5. ELECTRICAL CONNECTION

The EPC-2 is available from the factory as a 120 or 208 VAC, 1 phase, 60 hz. unit, or a 230V, 1 phase, 50 hz. unit.

The EPC-3 & EPC-4 is available from the factory as a 208 or 240 VAC, 3 phase, 60 hz. unit, or a 400V, 3 phase, 50/60 hz. unit.

The data plate, located on the rear, interior of the unit, specifies the correct electrical supply. The unit requires a grounded receptacle with a separate electrical line protected by a fuse or circuit breaker of the proper rating.



To avoid electrical shock, the cabinet must be adequately and safely grounded (earthed) according to local electrical codes, and this appliance must be equipped with an external circuit breaker which will disconnect all ungrounded (unearthed) conductors. The main power switch on this appliance does not disconnect all line conductors.

(FOR EQUIPMENT WITH CE MARK ONLY!)

To prevent electric shock hazard this appliance must be bonded to other appliances or touchable metal surfaces in close proximity to this appliance with an equipotential bonding conductor. This appliance is equipped with an equipotential lug for this purpose. The equipotential lug is marked with the following symbol



2-5. ELECTRICAL CONNECTION
(Continued)

The tables below shows electrical ratings for the EPC-2, EPC-3 & EPC-4

Model Number	Ph	Volts	Watts	Amps	Model Number	Ph	Volts	Watts	Amps
EPC-2	1	120	2268	18.9	-	-	-	-	-
EPC-2	1	208	2147	10.3	-	-	-	-	-
EPC-2	1	230	2093	9.1					
EPC-4-Short	1	208	4584	22.0	EPC-3-Short	1	208	3570	17.2
EPC-4-Short	3	208	4584	19.0	EPC-3-Short	3	208	3570	14.8
EPC-4-Short	1	240	4600	20.0	EPC-3-Short	1	240	3578	15.7
EPC-4-Short	3	240	4600	16.5	EPC-3-Short	3	240	3578	12.8
EPC-4-Short	3	400	4595	7.5	EPC-3-Short	3	400	3575	8.5
EPC-4-Tall (3 shelf)	1	208	5134	24.7	EPC-3-Tall (3 shelf)	1	208	4010	19.3
EPC-4-Tall (3 shelf)	3	208	5134	21.1	EPC-3-Tall (3 shelf)	3	208	4010	16.5
EPC-4-Tall (3 shelf)	1	240	5149	22.3	EPC-3-Tall (3 shelf)	1	240	4018	17.5
EPC-4-Tall (3 shelf)	3	240	5149	18.3	EPC-3-Tall (3 shelf)	3	240	4018	14.3
EPC-4-Tall (3 shelf)	3	400	5145	8.8	EPC-3-Tall (3 shelf)	3	400	4016	10.4
EPC-4-Tall (4 shelf)	1	208	5684	27.3	EPC-3-Tall (4 shelf)	1	208	4450	21.4
EPC-4-Tall (4 shelf)	3	208	5684	23.4	EPC-3-Tall (4 shelf)	3	208	4450	18.3
EPC-4-Tall (4 shelf)	1	240	5700	24.5	EPC-3-Tall (4 shelf)	1	240	4458	19.4
EPC-4-Tall (4 shelf)	3	240	5700	20.2	EPC-3-Tall (4 shelf)	3	240	4458	15.9
EPC-4-Tall (4 shelf)	3	400	5700	8.8	EPC-3-Tall (4 shelf)	3	400	4456	10.4

SECTION 3. OPERATION

3-1. INTRODUCTION



This section provides explanations of all controls, along with operating procedures and daily maintenance. Read the Introduction, Installation and Operation Sections before operating the unit.

NOTICE

To access the controls, the bottom, front panel must be removed by pulling out on one corner of the panel and unsnapping it from the clips.

3-2. OPERATING CONTROLS

Refer to control diagrams on next page.

Item No.	Description	Function
not shown	Power Switch	A rocker switch that sends electrical current to the operating components and lights when turned on
1	Digital Display	Shows the cabinet temperature, error codes and the selections in the Program Modes
2		Press to set the base shelf heat value and to toggle through the Program Mode
3		<p>Lights when the heat is on for that shelf</p> <p>Press and hold to set the shelf heat value. The bold line indicates the shelf being preset.</p>
4		Used to set the heat values of the shelves and base; press and hold, while turning on power switch to enter the Special Program Mode; used in Special Program Mode to turn off and on heat outputs

NOTICE

The first 2 shelf buttons are also used in the Special Program Mode to turn on and off the heat outputs for each shelf

3-2. OPERATING CONTROLS (Continued)

Short, In-line Units

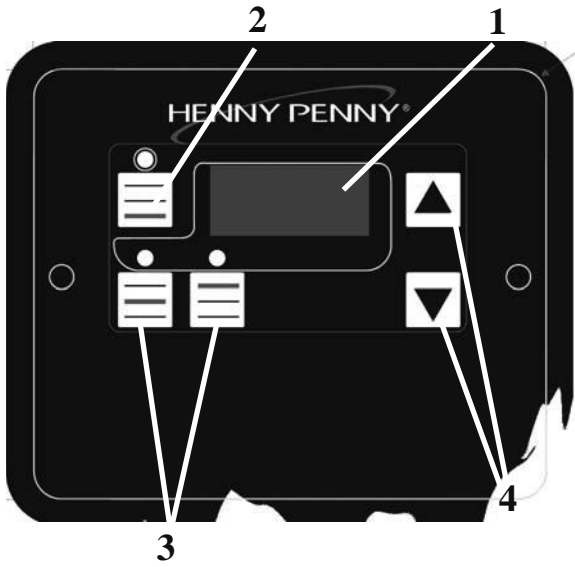

Tall, 3 shelf Units

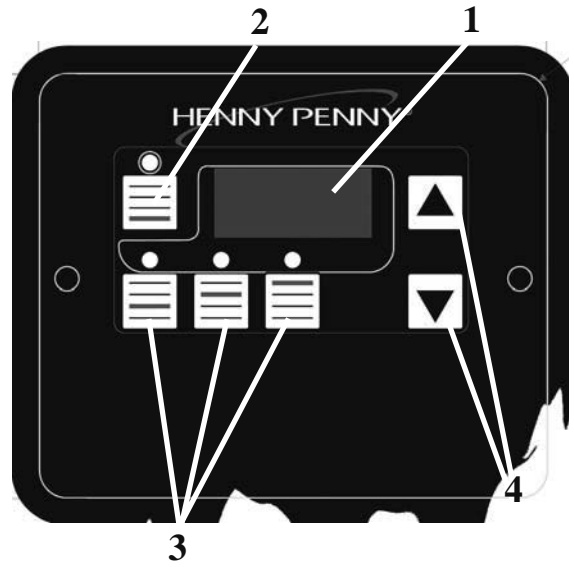

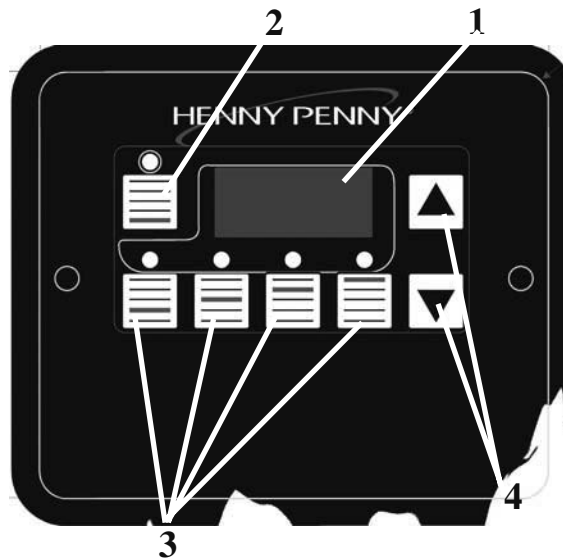

Tall, 4 shelf units



3-3. START UP

NOTICE



Before using the heated express cabinet, thoroughly clean the unit as described in the Cleaning Procedures Section of this manual.

1. Turn the power switch to the ON position.
2. Press and hold  and use  to set the heat value of the base shelf. It can be set from “OFF” to a maximum of “10”.

NOTICE

The upper heat settings read 1, 2, 3, etc. 1 meaning the heat is on 10% of the time, 10 meaning the heat is on 100% of the time.

If “LOC” shows on the display when trying to set the heat value, this means the controls are locked and the settings cannot be changed until unlocked in the Special Program Mode.

3. Press and hold each shelf button and use  to set the heat value to each corresponding shelf. These can be set from “OFF” to a maximum of “10”. Use the diagram below the buttons to find which button controls which shelf. Ex: Press and hold  to set the middle shelf heat value.

NOTICE

*Recommended settings to hold prepackaged whole chickens at a safe temperature for up to 4 hours:

- EPC-2 - A heat value setting of **10** for all shelves
- EPC-3 & EPC-4 - A heat value setting of **9** - top 2 shelves
settings of **8** - lower shelves & deck

Settings for other products may differ.

It is also recommended to lock the controls once the settings are programmed (see Special Program Mode) to ensure the settings aren't changed by unauthorized personnel.

4. Allow unit to preheat for about 30 minutes, and then prepackaged food products can now be placed on each shelf.

***Up to four hour** holding times when the following ideal holding conditions are met:

- Ambient temperatures ranging anywhere between 70° to 74°F (21° to 23°C)
- Merchandiser holds 3.0 to 3.5 lb. (1.36 – 1.59 kg) chickens in domes [Pactiv CNC-6007]
- Shelf heat is set per recommendation in the Operations Manual
- Merchandiser is operated at rated voltage
- Chicken enters the merchandiser between 180° to 190°F (82° to 88°C)

3-4. OPERATION WITH PRODUCT

1. Place the hot, prepackaged product on each of the shelves.



All shelf surfaces are hot! Burns could result!

NOTICE

To assure quality product, stacking prepackaged product is not recommended.

Also, to hold prepackaged whole chickens at safe temperature for up to 4 hours, the product temperature must be above 180°F (82°C) when placed in the unit

2. Serve the product first that has been in the cabinet the longest.

3-5. CLEANING PROCEDURES

1. Turn power switch to OFF
2. Disconnect the electrical supply to the cabinet.



To avoid burns, allow the unit to cool before cleaning.

3. Remove all product from the cabinet.
4. Wipe down each shelf with a damp cloth, soap and water.

NOTICE

The panels in the base (bottom tier) can be removed for more thorough cleaning. The holes in the center of each panel help in removing the panels.

5. Remove the air diffuser assembly in the front of the unit and take to a sink and clean with soap and water. The plastic diffuser can be pushed out of the metal holder for cleaning.

CAUTION

DO NOT put plastic air diffuser in a dishwasher. The plastic diffuser is NOT dishwasher safe, and damage to the diffuser could result.



Figure 1

**3-5. CLEANING
PROCEDURES
(Continued)**

6. Clean the exterior of the cabinet with a damp cloth.

NOTICE

For stubborn spots on the black top cap, Henny Penny recommends the Foaming Degreaser - Part no. 12226 and for the side glass, Glass Cleaner - Part no. 12227.

See your local distributor for details.

7. Clean the side glass with non-streaking liquid glass cleaner and a soft cloth.. Do not use abrasive cleaners.

CAUTION

Do not use steel wool, other abrasive cleaners or cleaners/sanitizers containing chlorine, bromine, iodine or ammonia chemicals, as these will deteriorate the stainless steel material, shorten the life of the unit, and scratch the black coating on the side glass.

Do not use a water jet (pressure sprayer) to clean the unit, or component failure could result.

Do not use alcohol or alcohol-based cleaners (such as sanitizers) on the plastic shelves or LED lens covers, or damage to these components could result.

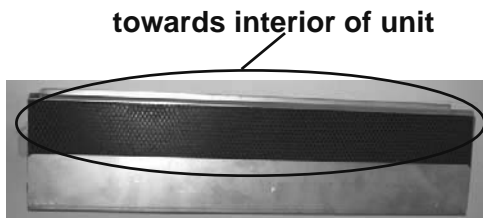

Figure 2

8. Replace diffuser properly into unit. Looking at the under-side of the diffuser assembly, the plastic diffuser must go towards the inside of the unit. Figure 2.

**CAUTION
FIRE HAZARD**

To prevent foreign objects from entering the air duct and to avoid the risk of fire, DO NOT operate unit without diffuser in place.

9. Allow the unit to thoroughly dry before adding more product.

3-6. SPECIAL PROGRAM MODE

This mode includes the lock/unlock feature, control initialization, and testing of the outputs and displays.

The shelf buttons are numbered in Figure 1 to indicate the correct shelf button to press in the following procedures.

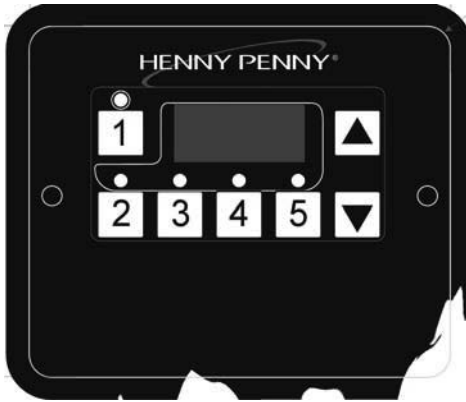

















Figure 1









1. Turn power switch off.
2. Press and hold both   while turning on the power switch.
3. “SP” shows in display, followed by “°F” or “°C”. Press  or  to change display to “°C” for Celsius, or “°F” for Fahrenheit. (Only applies to units showing temperature.)
4. Press  .
5. “P=L” or P=U” shows in display. Press  or  to either lock (“P=L”) or unlock (“P=U”) the controls.

Locking the controls will not allow anyone to change the heat values until the controls are unlocked.

6. Press  .
7. CAL shows in the display. Press  to show the air temperature + the offset value, and  press to show the offset value.

Press and hold  and use  and  to change the offset ± 50 degrees.
8. Press  .
9. CPU shows in the display. Press  to view the current temperature of the PC board and press  to view the highest temperature of the PC board.

**3-6. SPECIAL PROGRAM
MODE (Continued)**

10. “OP” shows in the display. Press and release the shelf buttons to turn off and on the heat outputs for each shelf. Press and release  to turn off and on the base heat outputs. Press  to turn off and on all displays and outputs.
11. Press  .
12. “In” shows in the display. Press and hold  or  to re-initialize the controls, which sets all heat settings to “OFF”, or to factory set parameters. “In3”, “In2”, “In1” shows in the display, followed by “In-”, “SyS”, indicating the initialization is complete.
13. Press  .
14. “CE=y” or “CE=n” shows in the display. Use  and  to toggle between CE=y and CE=n. If controls are set to CE=y, then the display shows the current air temperature during operation.

If controls are set to CE=n, then the display shows “ON” during operation.

9. Press and hold  to exit Special Program Mode.

NOTICE

Press and hold  at any time to exit the Special Program Mode, or if no buttons are pressed for 1 minute, controls automatically exits Special Program Mode.

SECTION 4. TROUBLESHOOTING

4-1. TROUBLESHOOTING GUIDE

Problem	Cause	Correction
Product not holding temperature	<ul style="list-style-type: none"> • Heat value of shelf not high enough • Product not hot when placed in cabinet 	<ul style="list-style-type: none"> • Set higher heat value in controls • Place prepackaged <u>hot</u> food in cabinet
With power switch on, unit is completely inoperative (NO POWER)	<ul style="list-style-type: none"> • Open Circuit 	<ul style="list-style-type: none"> • Check to see that unit is plugged in. • Check breaker or fuse at supply box
Shelf won't heat	<ul style="list-style-type: none"> • Shelf not plugged into receptacle properly 	<ul style="list-style-type: none"> • Check that the shelf plug is firmly pushed into receptacle, in the interior of the cabinet

4-2. ERROR CODES

DISPLAY	CAUSE	PANEL BOARD CORRECTION
"E04"	Control board overheating	Turn unit off and back on; if display shows "E04", the control board is getting too hot; make sure unit is not overheating
"E41"	Memory scrambled	Turn unit off and back on; if "E41" still shows on display, have PC board initialized; if "E41" persists replace the control board
"E06"	Air temperature too hot	Turn switch to OFF position, then turn switch back to ON; probe open if display shows "E06", the temperature probe should be checked
	Control set CE=y in Special Program Mode	Unit does not have a temperature probe and the controls must be set to CE=n, in Special Program Mode

GLOSSARY

HENNY PENNY HOLDING CABINETS

air temperature probe	a round device located inside the cabinet that measures the inside air temperature and sends that information to the control panel
air ducts	channels attached to the sides, of the inside of the unit, that directs the hot air towards the bottom of the unit; usually has tray supports attached to them
concentration ring assembly	a metal assembly located in the water pan in the bottom of the unit that helps keep an even humidity level inside the cabinet
clean water pan setpoint	a preset temperature at which a sensor warns the operator that the water pan has excessive lime deposits
control panel	the components that control the operating systems of the unit; the panel is located on the top front surface of the cabinet
deliming agent	a cleaner used to remove lime deposits in the water pan
drain valve	a device that lets the water drain from the water pan into a shallow pan on the floor; the valve should be closed while the unit is in use if humidity is desired
float switch	a device that senses low water levels in the water pan
food probe	a sensor located outside the cabinet that, when inserted into the product, communicates the temperature of the product to the control panel
food probe receptacle	the connection where the food probe is inserted in order to communicate with the control panel
humidity sensor	a device that measures the percentage of humidity inside the cabinet during use
humidity setting	a preset moisture level at which the cabinet operates; this setting is programmed at the factory but can be changed in the field
LED	an electronic light on the control panel
minimum holding temperature	the lowest temperature at which a food product can be safely held for human consumption
module	the removable top part of the cabinet that contains all of the operating system
out of water trip point	a preset temperature at which a sensor warns the operator that the water pan needs refilled
parameters	a preset group of setpoints designed for holding specific food products at certain temperature and humidity levels
power switch	the ON/OFF switch that sends electricity to the unit's operating systems; this switch does not disconnect the electrical power from the wall to the unit

pressure sprayer	a device that shoots a stream of water under pressure; this device should NOT be used to clean a holding cabinet
probe clip	a metal holder that attaches to the outside of the control panel to hold the food probe when not in use; the clip is an optional accessory
product load capacity	the highest recommended number of pounds/kilograms of food product that can be safely held in the cabinet
proof function	a program used for allowing bread to rise
relative humidity	the humidity level outside the cabinet
setpoint	a preset temperature or humidity; the setpoint is a programmable feature
system initialization	a programming process that resets factory settings
temperature setting	a preset temperature up to which the cabinet will heat; this setting is programmed at the factory but can be changed in the field
tray support	guides, attached to air ducts, for trays of product to be held in the unit
vent activation switch	an automatic control that opens and closes the vent on the rear of the cabinet to maintain the preset humidity level
vented panels	openings on the cabinet that allow air access on the sides and rear of the module
water fill line	the line marked on the inside of the water pan that shows the maximum water level to prevent overflow onto the floor
water heater sensor	a part in the water heater that sends a message to the controls when the water pan is limed up or empty
water jet	a device that shoots a stream of water under pressure; this type of device should NOT be used to clean a holding cabinet
water pan	the area in the cabinet that holds water for creating humidity inside the cabinet



Henny Penny Corporation
P.O.Box 60
Eaton, OH 45320

1-937-456-8400
1-937-456-8402 Fax

Toll free in USA
1-800-417-8417
1-800-417-8434 Fax

www.hennypenny.com

* FM05 - 049 - * * Henny Penny Corp., Eaton, Ohio 45320, Revised 6-2-10