



**Henny Penny
Fryer Shuttle
Model FS-100
Model FS-200**

OPERATOR'S MANUAL

SAFETY

Where information is of particular importance or is safety related, the words NOTICE, CAUTION, or WARNING are used. Their usage is described below:



SAFETY ALERT SYMBOL is used with DANGER, WARNING, or CAUTION which indicates a personal injury type hazard.



NOTICE is used to highlight especially important information.



CAUTION used without the safety alert symbol indicates a potentially hazardous situation which, if not avoided, may result in property damage.



CAUTION used with the safety alert symbol indicates a potentially hazardous situation which, if not avoided, may result in minor or moderate injury.



WARNING indicates a potentially hazardous situation which, if not avoided, could result in death or serious injury.



DANGER INDICATES AN IMMINENTLY HAZARDOUS SITUATION WHICH, IF NOT AVOIDED, WILL RESULT IN DEATH OR SERIOUS INJURY.

Optional Pouring Spout Extension Installation

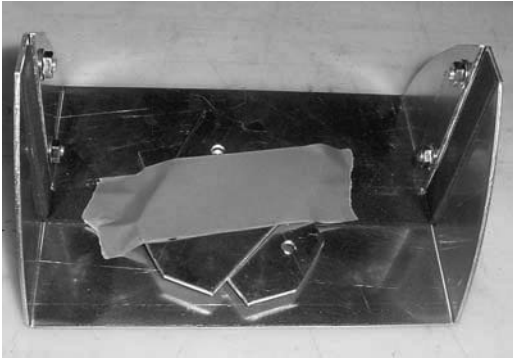

Figure 1

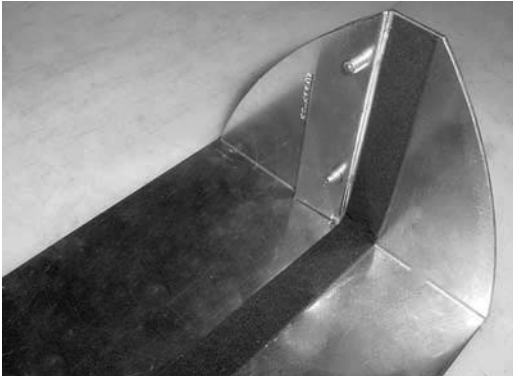

Figure 2



Figure 3 Notch



Gasket Seal **Figure 4**

1. Remove nuts and taped brackets from the extension as shown in Figure 1.
 2. Lay the Shortening Shuttle™ flat on the floor or table.
 3. Leaving the small bracket on the threaded studs (Figure 2) spread the extension out and fit it over the spout of shuttle. Make sure the small bracket rests on the edge of the spout, and gasket fits along the top edge of the spout.
 4. Determine which set of threaded stud the larger brackets fits. The brackets have a slight bow to them and must be installed on the correct side. The bend goes towards the inside of the shuttle.
 5. Fit the larger brackets over the threaded studs. Make sure the notch in the larger bracket rests against the edge of the spout. Figure 3.
 6. Thread the nuts (previously removed) onto the threaded studs and tighten with a 7/16" wrench or socket. When the nuts are tightened, the lower part of the bracket squeezes the spout of the shuttle, securing the extension in place. Figure 4.
- NOTICE**
- The brackets and extension may need squeezed together with pliers or vise-grips to allow enough threads to show through to start nuts on threads of studs.
7. Shortening Shuttle™ is now ready for use.

OPERATING INSTRUCTIONS



Figure 1

1. Position shuttle in front of fryer. Be sure shuttle is completely empty before using. Figure 1.



When using Shortening Shuttle™, touch handles only. Wear protective gloves. Shuttle body can get very hot in use.



TO AVOID PERSONAL INJURY, BURNS, SPILLS, AND CORROSION:

- 1) **DO NOT FILL SHUTTLE WITH MORE THAN ONE FRYPOT OF SHORTENING.**
- 2) **NEVER PUT WATER AND/OR CLEANER IN THE SHORTENING SHUTTLE™**



Figure 2



To avoid personal injury, burns, spills, and corrosion, the Shortening Shuttle™ must be hand-held or laid flat on floor, when it contains hot shortening. Do not lean it, rest it, stand it up, or prop it, in any other position other than FLAT ON floor or resting, as intended, over grease dumpster.



Figure 3

2. Disconnect the faucet from the fryer. Figure 2.
3. Disconnect hose from shuttle and connect hose to fryer. Figure 3.



Figure 4

4. Open drain valve slowly! Drain only one frypot of shortening into drain pan at a time.
5. Turn pump motor on until one frypot of shortening is pumped from drain pan. Figure 4.
6. Turn pump motor off. Remove hose from fryer and reconnect to shuttle, to allow hose to drain.
7. Wheel shuttle to disposal container. Figure 5.
8. Hang shuttle over top of container. Figure 5.
9. Using container as a pivot, pick up bottom with handle and pour into container. Figure 5.
10. Empty immediately to avoid hardening of shortening. Be sure all shortening has been emptied from Shortening Shuttle™.
11. Repeat steps 1-10 until all frypots are empty.

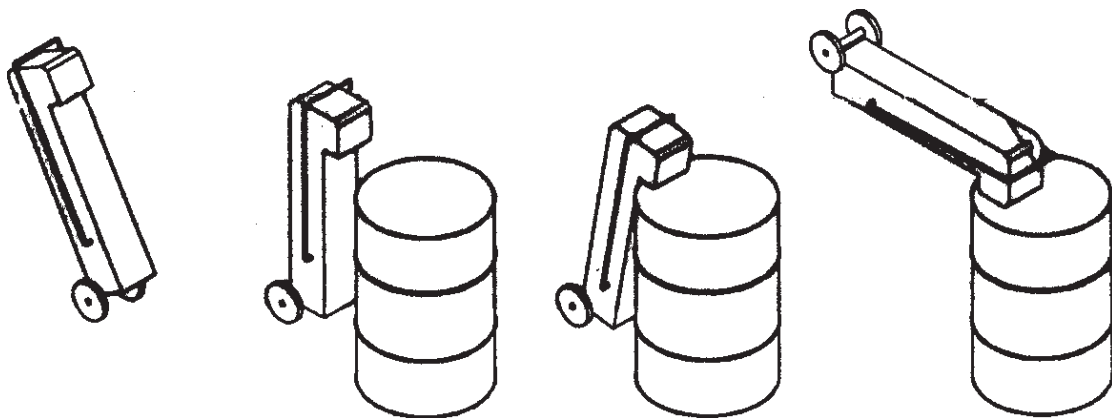
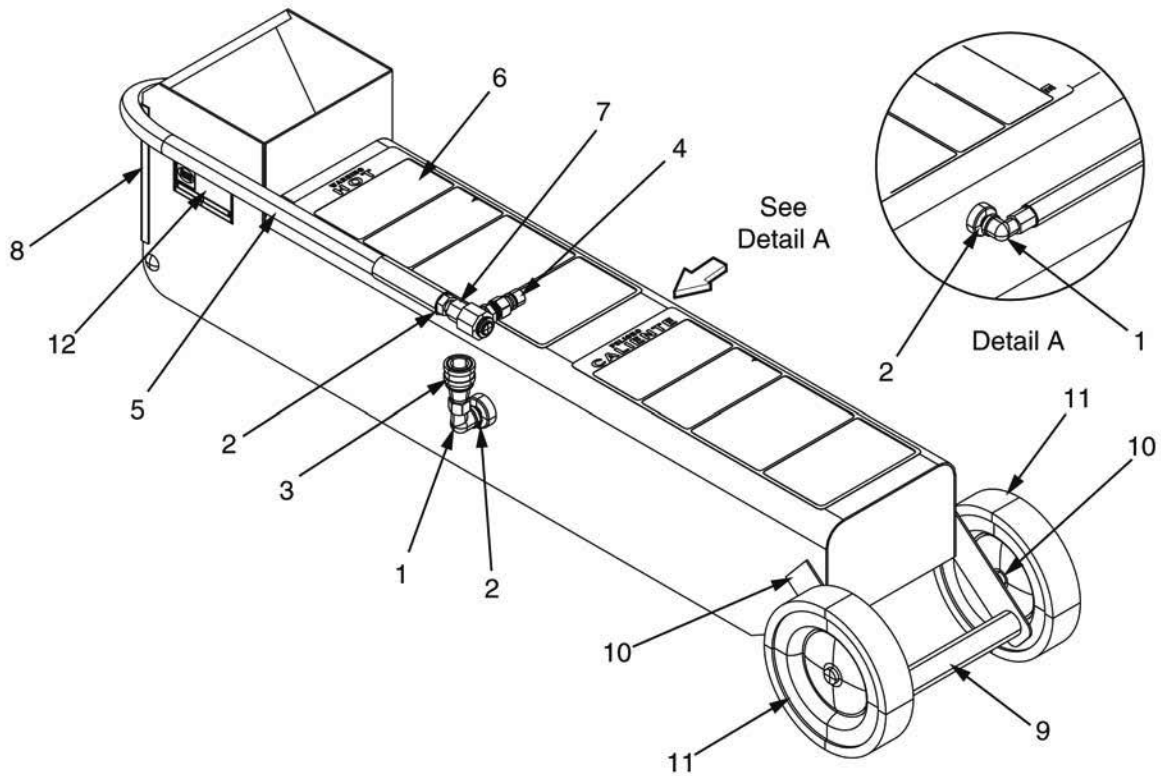

Figure 5



Parts List: FS-100 and FS-200

Item No.	Part No.	Description	Qty.
	33495	Shuttle - Shortening - FS-100	
	66409	Shuttle - Shortening - FS-200	
1	FP01-087	Elbow - Male - 3/8"	2
2	FP02-001	Nipple - Close - 3/8"	2
3	17333	Disconnect - Female	1
4	17334	Disconnect - Male	1
5	52247	Hose	1
6	33491	Label - Disposal Procedure	1
7	52703	Swivel - 3/8" NPT	1
8	52714	Slide - Hose Guard	2
9	33705	Kit - Wheel Handle	1
10	33706	Brackets - Wheel Handle	2
11	33707	Kit - Single Wheel	2
12	30412	Data Plate	1
13	33521*	Hook - Wall	1
14	66412*	Extension - Pouring Spout	1
15	33703*	Assembly - Baffle Screen	1
16	33704*	Kit - Top Handle	1
	* Not Shown		



**Henny Penny Corporation
P.O. Box 60
Eaton, OH 45320**

**1-937-456-8400
1-937-456-8402 Fax**

**Toll free in USA
1-800-417-8417
1-800-417-8434 Fax**

www.hennypenny.com

FM07-019-C Henny Penny Corp., Eaton, Ohio 45320, Revised 06-25-13