



OPERATOR'S M A N U A L

HUMIDIFIED COUNTER WARMER

MODEL

HCW-2

HCS-2

HCW-3

HCW-5

HCS-5

HCW-8



HENNY PENNY
Engineered to Last

REGISTER WARRANTY ONLINE AT WWW.HENNYPENNY.COM

TABLE OF CONTENTS

Section	Page
Section 1. INTRODUCTION	1-1
1-1. Heated Display Cabinet	1-1
1-2. Features	1-1
1-3. Proper Care	1-1
1-4. Assistance	1-1
1-5. Safety	1-2
Section 2. INSTALLATION	2-1
2-1. Introduction	2-1
2-2. Unpacking	2-1
2-3. Location	2-3
2-4. Remove Control End Panel	2-3
2-5. Drain Connection	2-4
2-6. Electric Connection	2-4
2-7. Electric Data Table	2-5
2-8. Water Supply Connection	2-5
2-9. Light Bulbs and Glass Panels	2-6
2-10. Cabinet Dimensions	2-7
Section 3. OPERATION	3-1
3-1. Introduction	3-1
3-2. Operating Controls	3-1
3-3. Start-Up	3-6
3-4. Operation with Product	3-7
3-5. Shut-Down and Cleanup	3-8
Section 4. TROUBLESHOOTING	4-1
4-1. Troubleshooting Guide	4-1
GLOSSARY	G-1

Distributor Lists - Domestic and International

SECTION 1. INTRODUCTION

1-1. HEATED DISPLAY CABINET

The Henny Penny Heated Display Cabinet is a basic unit of food processing equipment used to display the food product and maintain the temperature of hot foods in the commercial food service operation. This highly efficient, quality-built cabinet will keep hot foods at proper holding temperatures with controlled humidity. The Henny Penny Heated Display Cabinets have see-thru doors which allow viewing and access to the hot foods from both front and back.

NOTICE

As of August 16, 2005, the Waste Electrical and Electronic Equipment directive went into effect for the European Union. Our products have been evaluated to the WEEE directive. We have also reviewed our products to determine if they comply with the Restriction of Hazardous Substances directive (RoHS) and have redesigned our products as needed in order to comply. To continue compliance with these directives, this unit must not be disposed as unsorted municipal waste. For proper disposal, please contact your nearest Henny Penny distributor.



1-2. FEATURES

- Moist heat (HCS-2, HCW-3, and lower section HCW-5 and HCW-8)
- Dry heat in top section (HCW-5 and HCW-8 only)
- Easy to keep clean
- Automatic water fill system with manual bypass
- HCW-3 and the lower section HCW-5 holds three trays of product
- Lower section HCW-8 holds five trays
- Top section HCW-5 holds two trays of product
- Top section HCW-8 holds three trays
- All heat sources are adjustable
- Flip-up, see-through door panels

1-3. PROPER CARE

As in any unit of food service equipment, the Henny Penny Heated Display Cabinet does require care and maintenance. Requirements for the maintenance and cleaning are contained in this manual and must become a regular part of the operation of the unit at all times.

1-4. ASSISTANCE

Should you require outside assistance, just call your local independent Henny Penny distributor in your area, call Henny Penny Corp. at 1-800-417-8405 toll free or 1-937-456-8405, or go to Henny Penny online at www.hennypenny.com.

1-5. SAFETY

The only way to ensure safe operation of the Henny Penny Heated Display Cabinet is to fully understand the proper installation, operation, and maintenance procedures. The instructions in this manual have been prepared to aid you in learning the proper procedures. Where information is of particular importance or is safety related, the words NOTICE, CAUTION, or WARNING are used. Their usage is described below.



SAFETY ALERT SYMBOL is used with DANGER, WARNING, or CAUTION which indicates a personal injury type hazard.



NOTICE is used to highlight especially important information.



CAUTION used without the safety alert symbol indicates a potentially hazardous situation which, if not avoided, may result in property damage.



CAUTION indicates a potentially hazardous situation which, if not avoided, may result in minor or moderate injury.



The word WARNING is used to alert you to a procedure, that if not performed properly, might cause personal injury.

SECTION 2. INSTALLATION

2-1. INTRODUCTION

This section provides the installation instructions for the Henny Penny Heated Display Cabinet.

NOTICE

Installation of this unit should be performed only by a qualified service technician.



Do not puncture the skin of the unit with drills or screws as component damage or electrical shock could result.

2-2. UNPACKING



Step 1

The Henny Penny Heated Display Cabinet has been tested, inspected, and expertly packed to ensure arrival at its destination in the best possible condition. The cabinet has been bolted to a wooden skid. All glass items have been packed in cartons and taped inside the unit and the doors taped shut. The unit is then packed inside a triple wall corrugated carton with sufficient padding to withstand normal shipping treatment.

NOTICE

Any shipping damages should be noted in the presence of the delivery agent and signed prior to his or her departure.

To remove the Henny Penny Heated Display Cabinet from the carton, you should:

1. Carefully cut banding straps.

2-2. UNPACKING (Continued)



Step 2

2. Open top flaps and remove packing.



Step 3

3. Lift carton off skid.

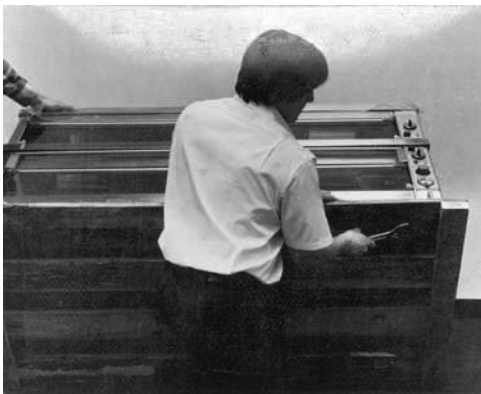

Step 4

4. Remove four bolts from under skid.

The unit is now ready for location and set-up.

2-3. LOCATION

Place the unit on a table, preferably with a cut-out opening below the cabinet to allow easy service connections and serviceability. When setting up the Henny Penny Heated Display Cabinet, be sure to level the table.

NOTICE

The unit has built-in draining capabilities, but this becomes ineffective when set on an unlevel table.

After the Henny Penny Heated Display Cabinet has been leveled on the table, run a bead of silicone rubber (silicone or equivalent sealant must be a NSF listed material) around the perimeter of the unit sealing it to the table top. You are now ready to make the electrical and drain connections to the unit.

2-4. REMOVE CONTROL END PANEL

1. Remove the seven screws fastening the end panel to the cabinet.
2. Slide bottom of end panel out first allowing top to drop below shelf edge.

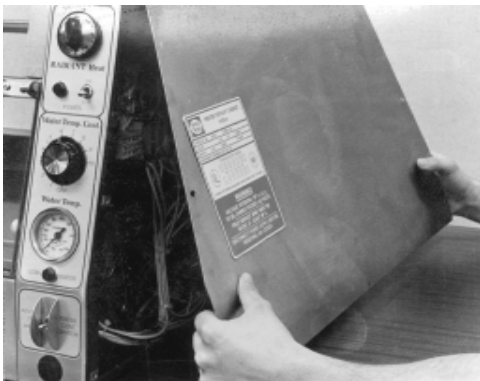

Step 2

2-5. DRAIN CONNECTION

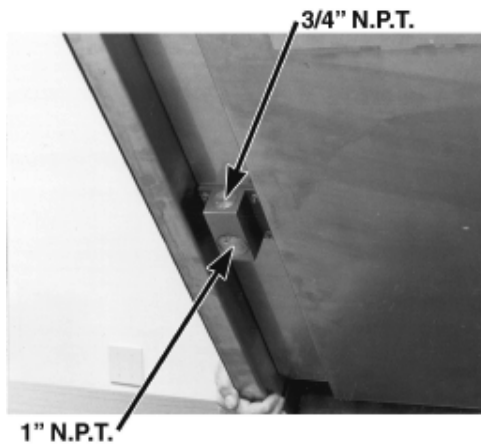

The drain can be connected to a 1 inch N.P.T. directly below the water well or to a 3/4 inch N.P.T. from the operator's side. We recommend the 1 inch N.P.T. connection as this will allow straight down draining of the water.

2-6. ELECTRIC CONNECTION

The heated display cabinet is available from the factory wired for 208 or 230 volts, single phase, 3-wire (includes neutral) or three phase, 4-wire (includes neutral) 60 Hz. service. The proper power service cable must be provided at installation. Check the data plate on the side panel of the control end to determine the correct power supply.



To avoid electrical shock, the cabinet must be adequately and safely grounded (earthed) according to local electrical codes.

(FOR EQUIPMENT WITH CE MARK ONLY!)

To prevent electric shock hazard this appliance must be bonded to other appliances or touchable metal surfaces in close proximity to this appliance with an equipotential bonding conductor. This appliance is equipped with an equipotential lug for this purpose. The equipotential lug is marked with the following symbol



A separate disconnect switch with proper capacity fuses or breakers must be installed at a convenient location between the cabinet and the power source. The field supply wiring to the cabinet should be an insulated copper conductor rated for 600 volts and 90°C.

2-6. ELECTRICAL CONNECTION
(Continued)

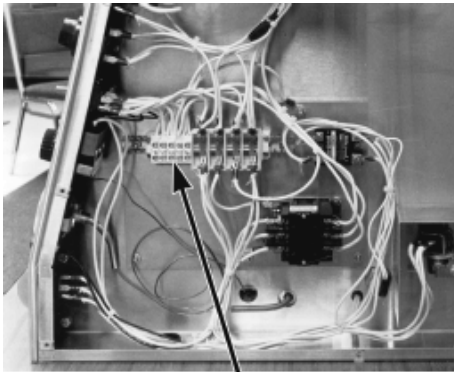

Electric Connection

The electrical power can be connected from the bottom or from the operator’s side. There is a 1-3/32 inch diameter hole for either connection. Again, we recommend the bottom connection as this will give a cleaner appearance to the unit. Please observe the electrical connection information on the data plate located on the side panel of the control end.

CAUTION

Voltage potential of L1 and L2 to ground cannot exceed 125 volts, or damage to the unit could result.

2-7. ELECTRIC DATA TABLE

Model	Volts	Phase	Watts	Amps
HCW-2	120/230	1	760	4.7
HCW-2	120/208	1	760	4.9
HCS-2	230	1	2852	12.4
HCW-3	120/230	3	3400	10.7
HCW-3	120/230	1	3400	16.3
HCW-3	120/208	3	3400	11.5
HCW-3	120/208	1	3400	17.6
HCW-3	400	3	3400	5.0
HCW-5	120/230	3	4160	12.2
HCW-5	120/230	1	4160	18.0
HCW-5	120/208	3	4160	13.1
HCW-5	120/208	1	4160	19.5
HCW-5	400	3	4160	6.0
HCW-8	120/208	3	8080	26.0
HCW-8	120/208	1	8080	40.0
HCW-8	120/230	3	8080	24.0
HCW-8	120/230	1	8080	35.1
HCW-8	400	3	8080	11.7
HCS-5	120/208	3	8080	22.6
HCS-5	120/208	1	8080	40.0
HCS-5	120/230	3	8080	19.8
HCS-5	120/230	1	8080	35.1
HCS-5	400	3	6680	9.7

2-8. WATER SUPPLY CONNECTION

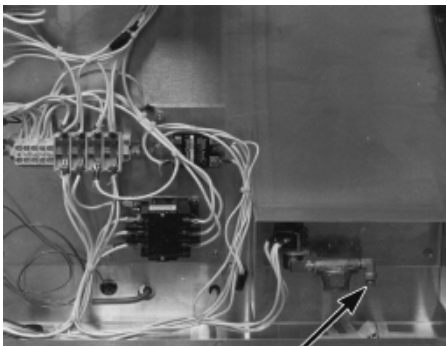

Water Supply Connection

The automatic water system has a 1/4 inch compression fitting for copper tubing. Hot water would be preferred. We recommend using the automatic water system as this will allow the unit to maintain a more even water temperature and help ensure that the unit never runs dry of water.

A straight-through bulkhead fitting is furnished with the unit for 1/4 inch copper tubing to protect the water line where it passes through the sheet metal.

Reinstall the end panel.

2-8. WATER SUPPLY CONNECTION
(Continued)

NOTICE

This unit as manufactured requires the installation of an appropriate back-siphoning device (as per National Plumbing Code ASA-A40.8-1955) to be connected to the water inlet line. This device to be connected in accordance to the basic plumbing code of the Building Officials and Code Administrators International, Inc. (BOCA), and the Food Service Sanitation Manual of the Food and Drug Administration (FDA).

A water shut-off valve should be installed in a convenient location.

2-9. LIGHT BULBS AND GLASS PANELS

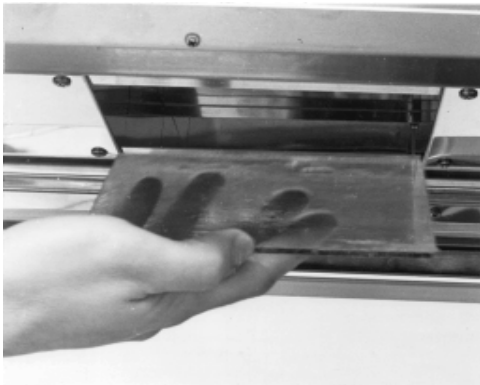

Step 1

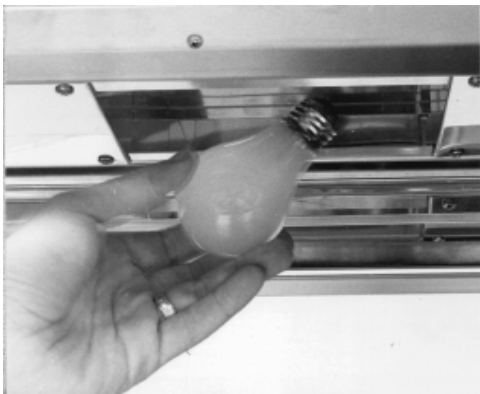

Step 2

1. Cut the tape holding the doors shut and remove all boxes and boxes and packing. One carton contains the glass panels and the other contains the light bulbs.
2. Install the light bulbs and glass panels.
3. The unit is now ready to be cleaned per instructions in the Operations section of this manual.

Replacing Light Bulbs

WARNING
BURN RISK

Light bulbs and glass may be hot. Severe burns could result.

1. Remove the glass panel by carefully pushing up on back of panel and sliding away from you. The panel will fall into your hand. See photo at left.
2. Remove the light bulb.
3. Replace the light bulb with a Westinghouse #60A19/35, 130 Volt bulb.

NOTICE

If this bulb is not available, a standard 60 watt bulb will work until a long life bulb can be obtained.

4. Replace the glass panel.

2-10. CABINET DIMENSIONS

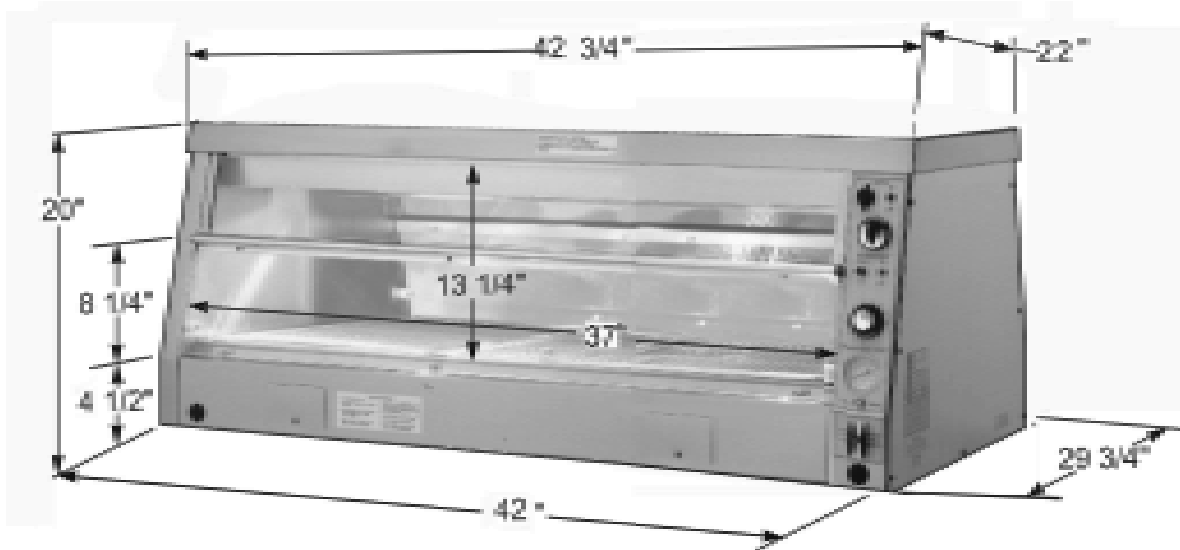

Model HCS-2

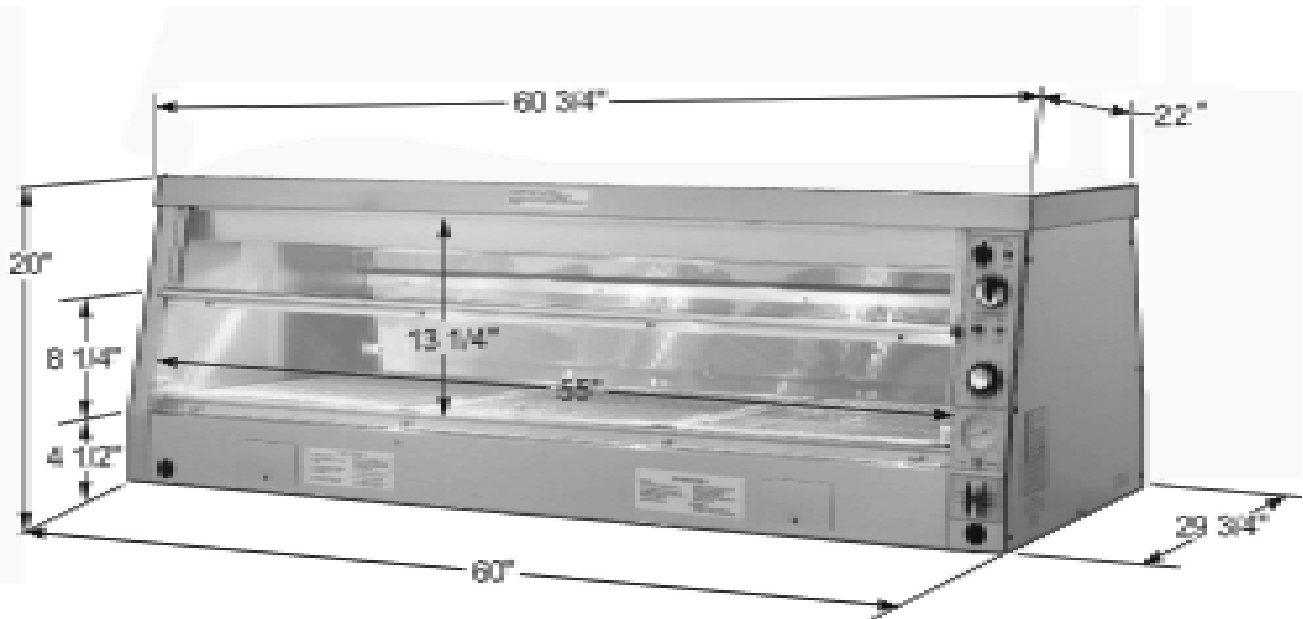

Model HCW-3

2-10. CABINET DIMENSIONS
(Continued)

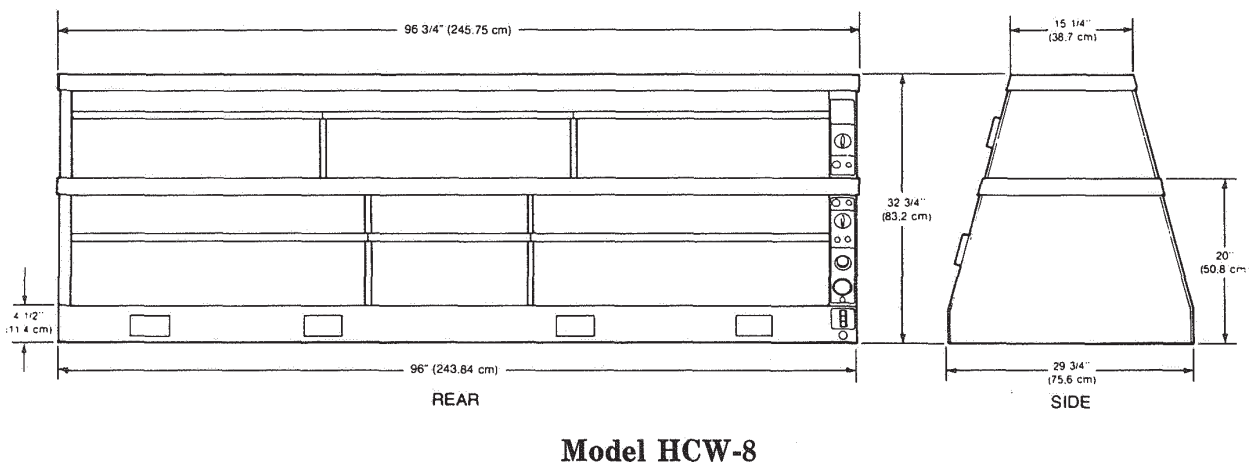
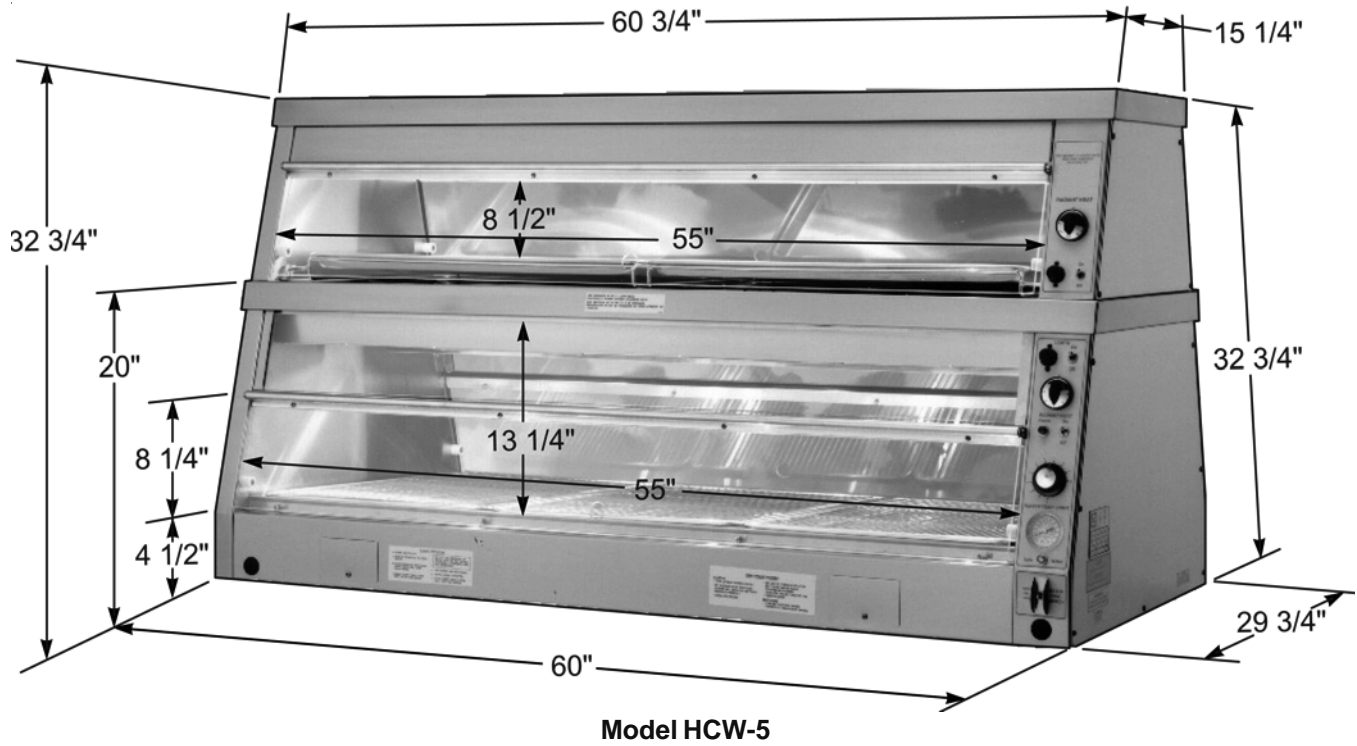

SECTION 3. OPERATING INSTRUCTIONS

3-1. INTRODUCTION

This section provides operating procedures for the heated display cabinets. The Introduction, Installation and Operation sections should be read, and all instructions should be followed before operating the cabinet.

3-2. OPERATING CONTROLS

Figures 3-1 through 3-12 identify and describe the function of all the operating controls and the major components of the cabinet.

3-2. OPERATING CONTROLS (Continued)

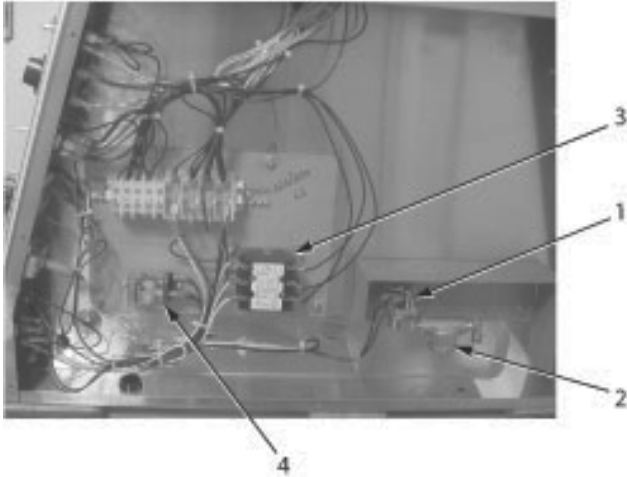

Figure 3-1

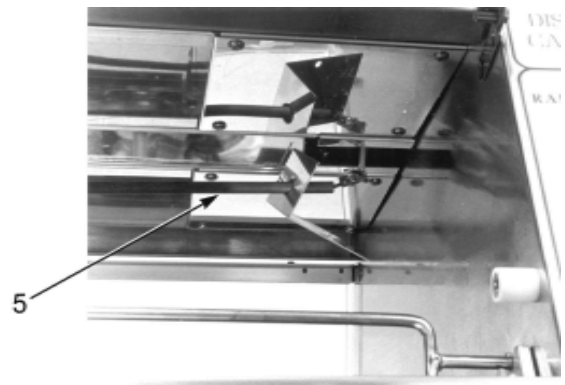

Figure 3-2

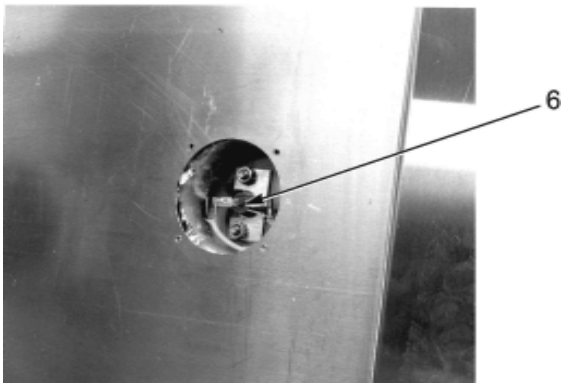

Figure 3-3



Figure 3-4

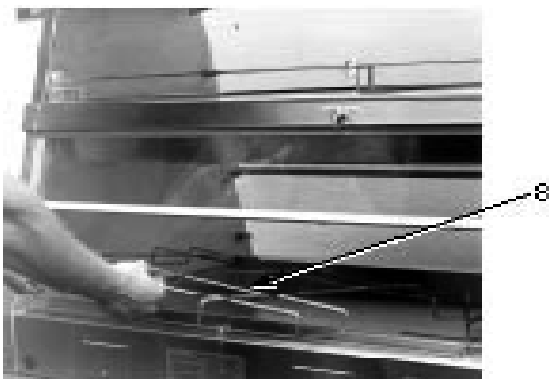

Figure 3-5



Figure 3-6

3-2. OPERATING CONTROLS (Continued)

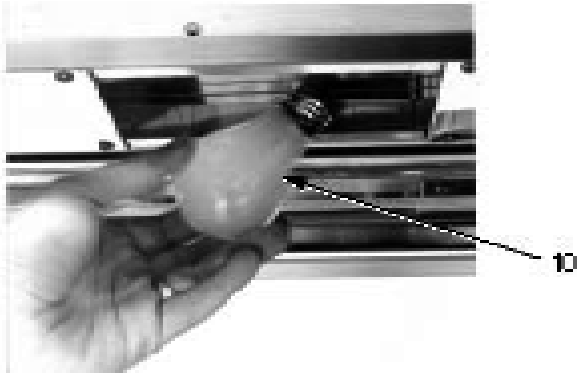

Figure 3-7

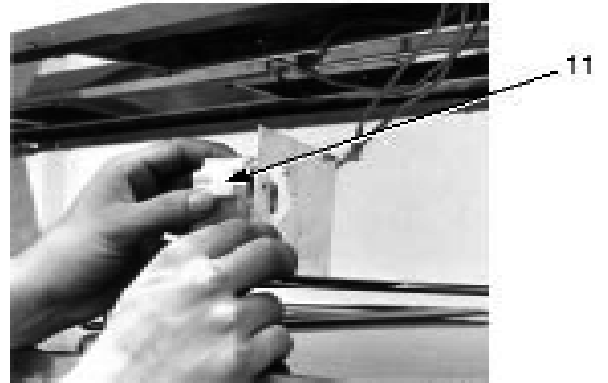

Figure 3-8



Figure 3-9

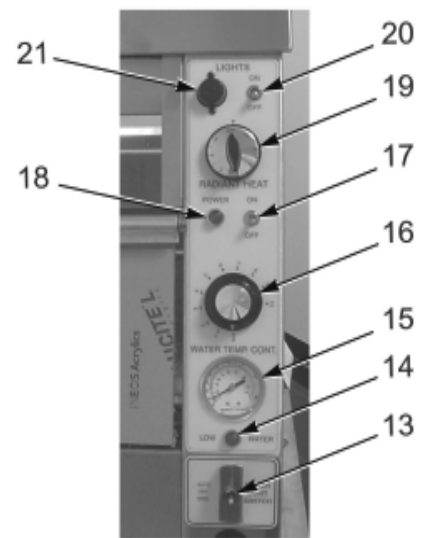

Figure 3-10



Figure 3-11

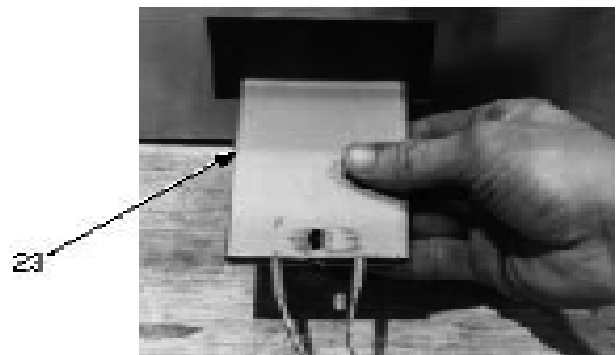

Figure 3-12

3-2. OPERATING CONTROLS (Continued)

Fig. No.	Item No.	Description	Function
3-1	1	Water Valve	An electrical solenoid valve energized by the float switch or the water control switch (in manual position) that allows water to flow into the water pan
3-1	2	Water Strainer	A filter to prevent particles plugging the water valve
3-1	3	Contactator	The relay that directs power to the water heaters
3-1	4	Relay	Shuts the heat off to the water pan when a low water condition is sensed by the float switch
3-2	5	Radiant Heater	A long tubular heater mounted in a reflector located in the ceiling panel of the unit
3-3	6	High Temperature Limit	A safety device mounted to the bottom of the water pan which detects an over temperature condition if the water pan runs dry
3-4	7	Perforated Bun Pan	Used over the water pan to allow the humidity to pass thru the chicken
3-5	8	Water Pan Grid	A grid that sets in the water pan to prevent a bun pan from dropping into the water when being lifted out
3-6	9	Pan Support - Top	Tilts the bun pans used in the top toward the customer side of the unit
3-7	10	Light Bulb	A 60 watt rated, long-life bulb that should be replaced by the same wattage bulb
3-8	11	Lamp Socket	A high temperature ceramic socket for holding the light bulb
3-9	12	Tinted Glass	Specially tempered colored glass with a thin film of silicone that protects the light bulbs as well as color the light

3-2. OPERATING CONTROLS (Continued)

Fig. No.	Item No.	Description	Function
3-10	13	Water Control Switch	A three-position switch with center position being OFF; in the position marked AUTOMATIC (up), the water level in the unit will be controlled by the float switch; in the position marked MANUAL (down), the water valve is opened directly by the switch; the MANUAL position is spring loaded so that the water valve will close when the switch is released
3-10	14	Water Light	A light operated directly by the float switch, which when illuminated, indicates low water conditions no matter what position the water control switch is in
3-10	15	Thermometer	Indicates the water temperature
3-10	16	Water Thermostat	An electro-mechanical device used to regulate the water temperature
3-10	17	Power Switch	A two-position, three pole switch used to turn on and off the heat and water control systems
3-10	18	Power Light	A light, when illuminated, indicating when the power switch is on and the heat and water system controls are energized; if the power light goes out during normal operation, this means the water pan high temperature limit has opened indicating that the unit is out of water
3-10	19	Radiant Heat Infinite Regulator	A time proportioning controller, which means the higher the number setting, the greater percentage of time the radiant heat will be on
3-10	20	Light Switch	A two-position, two pole switch used to turn the lights ON and OFF
3-10	21	Light Fuse Holder	A 15 amp protective device for the lighting circuit, that must be replaced by a fuse of the same size and rating

3-2. OPERATING CONTROLS (Continued)

Fig. No.	Item No.	Description	Function
3-11	22	Float Switch	An electro-mechanical sensing device used to automatically control the water level in the water pan; the float switch can be inactivated by the water control switch; the float switch illuminates the low water light when it senses a low water condition
3-12	23	Water Heater	Two flat strip heaters, attached to the bottom of the water pan, which measure approximately 3” wide by 25” long, and are rated at 1020 watts each

3-3. START-UP



Step 2

Before using, the Henny Penny Heated Display Cabinet should be thoroughly cleaned as indicated in the Shut-Down and Cleanup section of this manual.

1. Move all switches and controls on the cabinet to the OFF position.

2. Turn on power supply for the cabinet at the main circuit breaker.



Step 3

3. Place the grids in the water pan.

3-3. START-UP (Continued)



Step 4

NOTICE

4. Install the perforated bun pans over the water well. This will help in a more rapid heat up of the water.
5. Close the doors.
6. Turn the power switch to the ON position.
7. Turn the light switch to the ON position.
8. Turn the radiant heat switch to the desired setting. We recommend starting at “6” for the lower radiant. If you have upper radiant, start at “4”. These settings are adjustable and may change as you become familiar with the food product in this unit.
9. Turn the water control switch to AUTOMATIC.
10. After approximately one minute, turn the water thermostat to the desired setting. We recommend about 3.5 to 4 or a water temperature of 150°F.

3-4. OPERATION WITH PRODUCT

1. Place product on wire grids in the pans.
2. Serve product from the outside edges first. The product closest to the door opened often will cool fastest.
3. Only leave the doors open when demand requires. During slow periods, keep the doors closed.

NOTICE

When checking the HCW to make sure it's holding the product properly, use a temperature probe or pocket thermometer on the product and the water in the bottom of the unit. The product is kept warm by radiant heat and checking the air temperature inside the HCW will NOT indicate if the product is holding at the proper temperature. Also, even though the unit has a thermometer on the controls for the water temperature, it may not accurate.

3-5. SHUT-DOWN AND CLEANUP

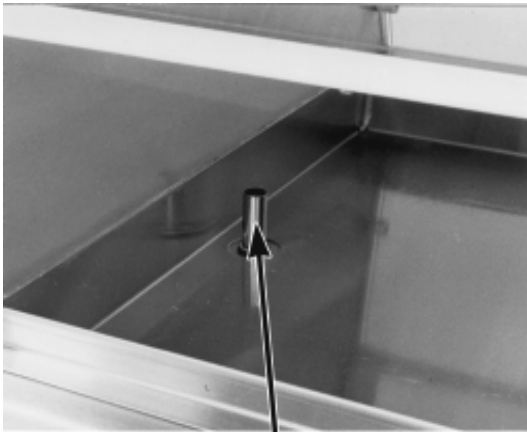

Drain Standpipe

Step 6

1. Turn the water thermostat to OFF.
2. Turn the radiant heat to OFF.
3. Turn the water control switch to OFF.
4. Open the doors.
5. Remove all the pans.
6. Remove the drain standpipe.
7. Remove the grids from the water pan and clean with soap and water at sink.
8. If cleaning a five-pan unit (HCW-5), or eight-pan unit (HCW-8), remove wire pan support from top section and clean with soap and water at sink.

CAUTION

Do not use steel wool, other abrasive cleaners or cleaners/sanitizers containing chlorine, bromine, iodine or ammonia chemicals, as these will deteriorate the stainless steel material and shorten the life of the unit.

Do not spray the unit with water, such as, with a garden hose. Failure to follow this caution could cause component failure.

9. Clean all surfaces with a soft cloth, soap, and water.
10. Clean around electrical controls with a damp cloth.
11. Install the drain standpipe.
12. Turn off the lights and power switch.
13. Leave the doors open until ready to use again.

SECTION 4. TROUBLESHOOTING

4-1. TROUBLESHOOTING GUIDE

PROBLEM	CAUSE	CORRECTION
Product not holding temperature	<ul style="list-style-type: none"> • Doors are not kept closed • Product held too long • Water temperature too low • Radiant heat too low • Light bulbs out 	<ul style="list-style-type: none"> • Keep doors closed when possible • Only hold product for recommended times • Turn to higher setting • Turn to higher setting • Replace as required, per Light Bulbs and Glass Panels section
Doors are fogging	<ul style="list-style-type: none"> • Doors left open too much allowing doors to cool and cause condensation • Radiant heat not high enough • Water temperature too high 	<ul style="list-style-type: none"> • Keep doors closed when possible • Turn to higher setting • See recommended settings and temperatures
Water will not fill	<ul style="list-style-type: none"> • Water supply has been shut-off or disconnected 	<ul style="list-style-type: none"> • Check the water supply
Lights will not turn on	<ul style="list-style-type: none"> • Defective fuse 	<ul style="list-style-type: none"> • Replace 15 amp fuse
Not all lights on	<ul style="list-style-type: none"> • Faulty light bulbs 	<ul style="list-style-type: none"> • Replace with recommended bulb, per Light Bulbs and Glass Panels section
Water will not reach desired temperature	<ul style="list-style-type: none"> • Bun pans are not over water 	<ul style="list-style-type: none"> • Place perforated bun pans over water

NOTICE

More detailed troubleshooting information is available in the Technical Manual, available at www.hennypenny.com, or 800-417-8405 or 937-456-8405.

GLOSSARY

HENNY PENNY HOLDING CABINETS

air temperature probe	a round device located inside the cabinet that measures the inside air temperature and sends that information to the control panel
concentration ring assembly	a metal assembly located in the water pan in the bottom of the unit that helps keep an even humidity level inside the cabinet
clean water pan setpoint	a preset temperature at which a sensor warns the operator that the water pan has excessive lime deposits
control panel	the components that control the operating systems of the unit; the panel is located on the top front surface of the cabinet
deliming agent	a cleaner used to remove lime deposits in the water pan
drain valve	a device that lets the water drain from the water pan into a shallow pan on the floor; the valve should be closed while the unit is in use if humidity is desired
float switch	a device that senses low water levels in the water pan
food probe	a sensor located outside the cabinet that, when inserted into the product, communicates the temperature of the product to the control panel
food probe receptacle	the connection where the food probe is inserted in order to communicate with the control panel
humidity sensor	a device that measures the percentage of humidity inside the cabinet during use
humidity setting	a preset moisture level at which the cabinet operates; this setting is programmed at the factory but can be changed in the field
LED	an electronic light on the control panel
minimum holding temperature	the lowest temperature at which a food product can be safely held for human consumption
module	the removable top part of the cabinet that contains all of the operating system
out of water trip point	a preset temperature at which a sensor warns the operator that the water pan needs refilled
parameters	a preset group of setpoints designed for holding specific food products at certain temperature and humidity levels
power switch	the ON/OFF switch that sends electricity to the unit's operating systems; this switch does not disconnect the electrical power from the wall to the unit
pressure sprayer	a device that shoots a stream of water under pressure; this device should NOT be used to clean a holding cabinet

probe clip	a metal holder that attaches to the outside of the control panel to hold the food probe when not in use; the clip is an optional accessory
product load capacity	the highest recommended number of pounds/kilograms of food product that can be safely held in the cabinet
proof function	a program used for allowing bread to rise
relative humidity	the humidity level outside the cabinet
setpoint	a preset temperature or humidity; the setpoint is a programmable feature
system initialization	a programming process that resets factory settings
temperature setting	a preset temperature up to which the cabinet will heat; this setting is programmed at the factory but can be changed in the field
vent activation switch	an automatic control that opens and closes the vent on the rear of the cabinet to maintain the preset humidity level
vented panels	openings on the cabinet that allow air access on the sides and rear of the module
water fill line	the line marked on the inside of the water pan that shows the maximum water level to prevent overflow onto the floor
water heater sensor	a part in the water heater that sends a message to the controls when the water pan is limed up or empty
water jet	a device that shoots a stream of water under pressure; this type of device should NOT be used to clean a holding cabinet
water pan	the area in the cabinet that holds water for creating humidity inside the cabinet



**Henny Penny Corporation
P.O. Box 60
Eaton, OH 45320**

**1-937-456-8400
1-937-456-8402 Fax**

**Toll free in USA
1-800-417-8417
1-800-417-8434 Fax**

www.hennypenny.com

FM05-019-G Henny Penny Corp., Eaton, Ohio 45320, Revised 6-26-13