



# **Henny Penny Heated Express Cabinet**

**Model HEC-103**

**Model HEC-104**

**Model HEC-123**

**Model HEC-124**

**TECHNICAL MANUAL**



## **LIMITED WARRANTY FOR HENNY PENNY EQUIPMENT**

Subject to the following conditions, Henny Penny Corporation makes the following limited warranties to the original purchaser only for Henny Penny appliances and replacement parts:

**NEW EQUIPMENT:** Any part of a new appliance, except baskets, lamps, and fuses, which proves to be defective in material or workmanship within two (2) years from date of original installation, will be repaired or replaced without charge F.O.B. factory, Eaton, Ohio, or F.O.B. authorized distributor. Baskets will be repaired or replaced for ninety (90) days from date of original installation. Lamps and fuses are not covered under this Limited Warranty. To validate this warranty, the registration card for the appliance must be mailed to Henny Penny within ten (10) days after installation.

**FILTER SYSTEM:** Failure of any parts within a fryer filter system caused by the use of the non-OEM filters or other unapproved filters is not covered under this Limited Warranty.

**REPLACEMENT PARTS:** Any appliance replacement part, except lamps and fuses, which proves to be defective in material or workmanship within ninety (90) days from date of original installation will be repaired or replaced without charge F.O.B. factory, Eaton, Ohio, or F.O.B. authorized distributor.

The warranty for new equipment covers the repair or replacement of the defective part and includes labor charges and maximum mileage charges of 200 miles round trip for a period of one (1) year from the date of original installation.

The warranty for replacement parts covers only the repair or replacement of the defective part and does not include any labor charges for the removal and installation of any parts, travel, or other expenses incidental to the repair or replacement of a part.

**EXTENDED FRYPOT WARRANTY:** Henny Penny will replace any frypot that fails due to manufacturing or workmanship issues for a period of up to seven (7) years from date of manufacture. This warranty shall not cover any frypot that fails due to any misuse or abuse, such as heating of the frypot without shortening.

**0 TO 3 YEARS:** During this time, any frypot that fails due to manufacturing or workmanship issues will be replaced at no charge for parts, labor, or freight. Henny Penny will either install a new frypot at no cost or provide a new or reconditioned replacement fryer at no cost.

**3 TO 7 YEARS:** During this time, any frypot that fails due to manufacturing or workmanship issues will be replaced at no charge for the frypot only. Any freight charges and labor costs to install the new frypot as well as the cost of any other parts replaced, such as insulation, thermal sensors, high limits, fittings, and hardware, will be the responsibility of the owner.

Any claim must be presented to either Henny Penny or the distributor from whom the appliance was purchased. No allowance will be granted for repairs made by anyone else without Henny Penny's written consent. If damage occurs during shipping, notify the sender at once so that a claim may be filed.

THE ABOVE LIMITED WARRANTY SETS FORTH THE SOLE REMEDY AGAINST HENNY PENNY FOR ANY BREACH OF WARRANTY OR OTHER TERM. BUYER AGREES THAT NO OTHER REMEDY (INCLUDING CLAIMS FOR ANY INCIDENTAL OR CONSEQUENTIAL DAMAGES) SHALL BE AVAILABLE.

The above limited warranty does not apply (a) to damage resulting from accident, alteration, misuse, or abuse; (b) if the equipment's serial number is removed or defaced; or (c) for lamps and fuses. THE ABOVE LIMITED WARRANTY IS EXPRESSLY IN LIEU OF ALL OTHER WARRANTIES, EXPRESS OR IMPLIED, INCLUDING MERCHANTABILITY AND FITNESS, AND ALL OTHER WARRANTIES ARE EXCLUDED. HENNY PENNY NEITHER ASSUMES NOR AUTHORIZES ANY PERSON TO ASSUME FOR IT ANY OTHER OBLIGATION OR LIABILITY.

Revised 01/01/07

## TABLE OF CONTENTS

Section	Page
Section 1. TROUBLESHOOTING	
1-1. Introduction .....	1-1
1-2. Safety .....	1-1
1-3. Troubleshooting .....	1-1
1-4. Error Codes and Warnings .....	1-3
Section 2. MAINTENANCE	
2-1. Introduction .....	2-1
2-2. Maintenance Hints .....	2-1
2-3. Lamp Socket Replacement .....	2-1
2-4. Ballast Replacement .....	2-4
2-5. Base Heaters .....	2-5
2-6. Transformers .....	2-5
2-7. Relays .....	2-6
2-8. Fuse and Fuse Holder Replacement .....	2-8
2-9. Power Switch Replacement .....	2-9
2-10. Contactor Replacement .....	2-10
2-11. PC Board Replacement .....	2-10
2-12. Heated Shelf Replacement .....	2-12
Wiring Diagrams .....	2-13
Section 3. PARTS INFORMATION	
3-1. Introduction .....	3-1
3-2. Genuine Parts .....	3-1
3-3. How to Order .....	3-1
3-4. Prices .....	3-1
3-5. Delivery .....	3-1
3-6. Warranty .....	3-1
3-7. Recommended Spare Parts for Distributors .....	3-1

**SECTION 1. TROUBLESHOOTING**

**1-1. INTRODUCTION**

This section provides troubleshooting information in the form of and easy to read table.

If a problem occurs during the first operation of a new unit, recheck the Installation Section of the Operator’s Manual.

Before troubleshooting, always recheck the operating procedure per the Operation Section of the Operator’s Manual.

**1-2. SAFETY**

Where information is of particular importance or is safety related, the words, NOTICE, CAUTION, or WARNING are used. Their usage is described below.



SAFETY ALERT SYMBOL is used with DANGER, WARNING, or CAUTION which indicates a personal injury type hazard.



NOTICE is used to highlight especially important information.



*CAUTION used without the safety alert symbol indicates a potentially hazardous situation which, if not avoided, may result in property damage.*



*CAUTION used with the safety alert symbol indicates a potentially hazardous situation which, if not avoided, may result in minor or moderate injury.*



**WARNING indicates a potentially hazardous situation which, if not avoided, could result in death or serious injury.**

**1-3. TROUBLESHOOTING**

To isolate a malfunction, proceed as follows:

1. Clearly define the problem (or symptom) and when it occurs.
2. Locate the problem in the troubleshooting table.
3. Review all possible causes. Then, one-at-a-time work through the list of corrections until the problem is solved.

**1-3. TROUBLESHOOTING (Continued)**

PROBLEM	CAUSE	CORRECTION
<p>With power switch in POWER position, unit is completely inoperative (no power)</p>	<ul style="list-style-type: none"> <li>• Open circuit</li>   <li>• Control board defective</li>   <li>• Transformer defective</li> </ul>	<ul style="list-style-type: none"> <li>• Check to see that unit is plugged in</li>   <li>• Check breaker or fuse at supply box</li>   <li>• Check control panel fuses per Fuse and Fuse Holder Replacement Section</li>   <li>• Check voltage at wall receptacle</li>   <li>• Check POWER switch; replace if defective</li>   <li>• Check cord and plug for loose connections</li>   <li>• Check for 12 volt input from transformer; replace if defective</li>   <li>• Check input and output voltage; replace if defective</li> </ul>
<p>Unit will not heat</p>	<ul style="list-style-type: none"> <li>• Control board not calling for heat</li>   <li>• Faulty contactor</li> </ul>	<ul style="list-style-type: none"> <li>• Check set point reading; if unit below setpoint and not calling for heat, control board defective</li>   <li>• Check contactor and replace if necessary</li> </ul>
<p>No shelf heat</p>	<ul style="list-style-type: none"> <li>• Faulty shelf heat relay</li>   <li>• Faulty shelf heater</li>   <li>• Unit not preheated</li>   <li>• Faulty PC board</li>   <li>• Temperature setting “OFF”</li>   <li>• Shelf not plugged into receptacle properly</li> </ul>	<ul style="list-style-type: none"> <li>• Check and replace if necessary</li>   <li>• Check and replace if necessary</li>   <li>• Preheat unit before loading product</li>   <li>• Replace PC board</li>   <li>• Remove front cover and increase shelf heat setting</li>   <li>• Check that the shelf plug is firmly pushed into receptacle, in the interior of the cabinet</li> </ul>

**1-3. TROUBLESHOOTING (Continued)**

<b>PROBLEM</b>	<b>CAUSE</b>	<b>CORRECTION</b>
No base heat	<ul style="list-style-type: none"> <li>• Faulty base heat relay</li> <li>• Faulty base heater</li> <li>• Unit not preheated</li> <li>• Faulty PC board</li> </ul>	<ul style="list-style-type: none"> <li>• Check and replace if necessary</li> <li>• Check and replace if necessary</li> <li>• Preheat unit before loading product</li> <li>• Replace PC board</li> </ul>
No light(s)	<ul style="list-style-type: none"> <li>• Faulty contactor</li> <li>• Light socket shorted</li> <li>• Faulty fluorescent light bulb</li> <li>• Faulty lamp ballast</li> </ul>	<ul style="list-style-type: none"> <li>• Check contactor and replace if necessary</li> <li>• Replace light socket</li> <li>• Replace fluorescent light bulb</li> <li>• Replace ballast</li> </ul>
Product not holding temperature	<ul style="list-style-type: none"> <li>• Heat settings too low</li> <li>• Low or improper voltage</li> <li>• Product held too long</li> <li>• Product not placed correctly in unit</li> <li>• Product not hot when placed in</li> </ul>	<ul style="list-style-type: none"> <li>• Remove front cover and adjust shelf and base heat settings</li> <li>• Using meter, compare receptacle voltage to data plate voltage</li> <li>• Hold product for recommended time</li> <li>• Place product in unit as per Operation with Product Section of Operator’s Manual</li> <li>• Place prepackaged <u>hot</u> food in cabinet</li> </ul>

**1-4. ERROR CODES AND WARNINGS**

The display shows the following error codes and warnings when a fault is detected, along with an alarm sound. Both the heat and humidity systems shut down, except when specified otherwise.

<b>DISPLAY</b>	<b>CAUSE</b>	<b>CORRECTION</b>
“E04”	<ul style="list-style-type: none"> <li>• Control board temperature above 140° F (60° C)</li> </ul>	<ul style="list-style-type: none"> <li>• Check unit for overheating; if not overheating and “E04” persists, replace PC board</li> </ul>
“E41	<ul style="list-style-type: none"> <li>• Scrambled PC board memory</li> </ul>	<ul style="list-style-type: none"> <li>• Press UP button to clear “E41”; if “E41” persists, replace PC board</li> </ul>

## SECTION 2. MAINTENANCE

### 2-1. INTRODUCTION

This section provides procedures for the checkout and replacement of the various parts used within the heated merchandiser. Before replacing any parts, refer to the Troubleshooting Section. It will aid you in determining the cause of the malfunction.

### 2-2. MAINTENANCE HINTS

1. You may want to use a multimeter to check the electric components.
2. When the manual refers to the circuit being closed, the multimeter should read zero unless otherwise noted.
3. When the manual refers to the circuit being open, the multimeter reads infinity.

### 2-3. LAMP SOCKET REPLACEMENT

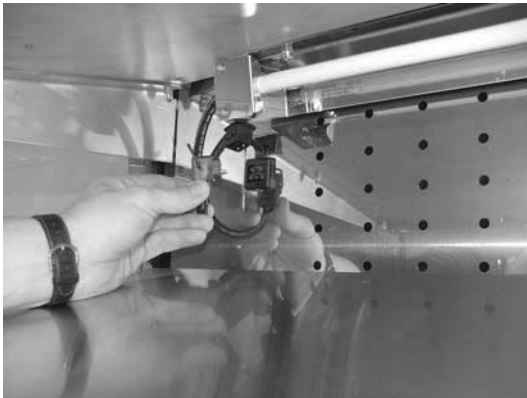

**Figure 1**

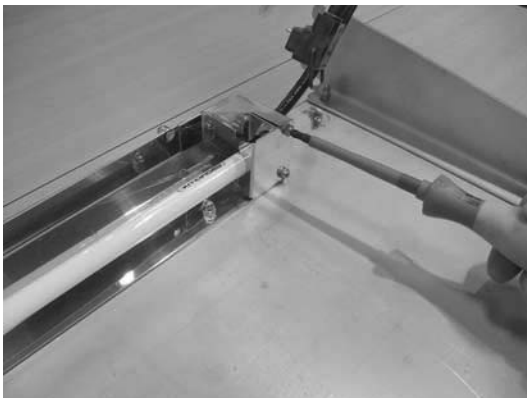

**Figure 2**



**To avoid electrical shock or property damage, move the POWER switch to OFF and disconnect main circuit breaker, or unplug cord at wall receptacle.**

**To avoid burns, allow the unit to cool before servicing.**

#### **Shelf Lamp Socket**

1. Unplug both sides of the shelf with the faulty lamp socket. Figure 1.
2. Lift shelf from unit.
3. Remove the screws securing the fluorescent bulb guards on both ends of the bulb, and remove guards. Figure 2.



**2-3. LAMP SOCKET REPLACEMENT**  
**(Continued)**

4. Twist bulb and remove from shelf.



**Figure 3**

5. Using a 5/16" socket for the rear, and 3/8" socket for the front, remove all acorn nuts from the lamp reflector. Figure 3.

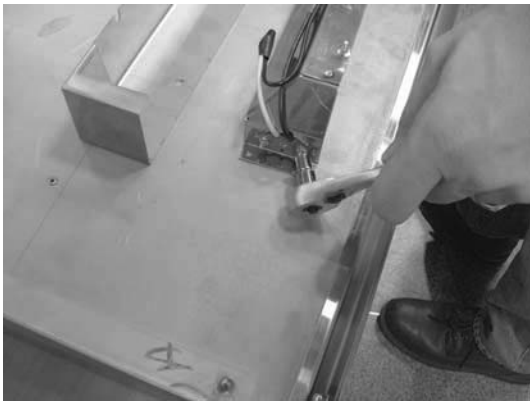

**Figure 4**

6. Pull reflector apart and using 1/4" socket remove nuts securing the faulty socket. Figure 4.



**Figure 5**

7. Disconnect wires and remove faulty socket from reflector. Figure 5.

8. Install new lamp socket in reverse order.

## **2-3. LAMP SOCKET REPLACEMENT** **(Continued)**



**Figure 6**

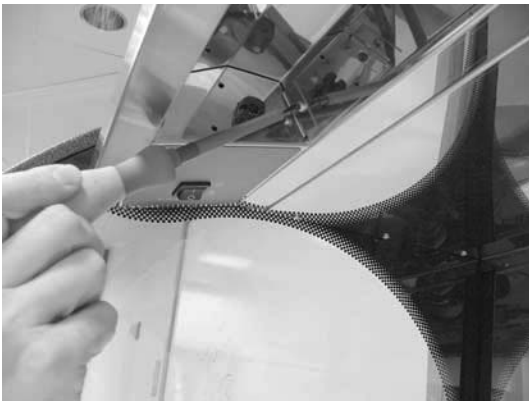

**Figure 7**



**Figure 8**

### **Canopy Lamp Socket**

1. Remove the screws securing the fluorescent bulb guards on both ends of the bulb, and remove guards. Figure 6.
2. Twist bulb and remove from canopy.
3. Remove screws securing both ends of the canopy lamp reflector, and allow reflector to drop down. Figure 7.
4. Pull wires down from canopy and disconnect the wire connectors. Figure 8.
5. Using a 1/4" socket, remove nuts securing the faulty socket, and remove socket from reflector.
6. Install new lamp socket in reverse order.

## **2-4. BALLAST REPLACEMENT**



**Figure 1**

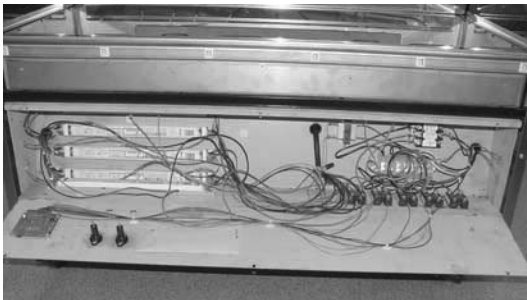

**Figure 2**

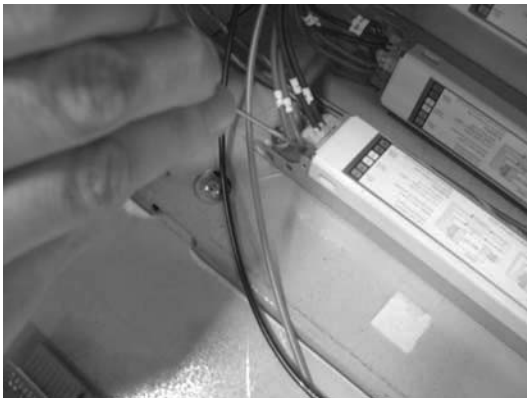

**Figure 3**



**Figure 4**



To avoid electrical shock or property damage, move the **POWER** switch to **OFF** and disconnect main circuit breaker, or unplug cord at wall receptacle.

1. Carefully pry out on the front cover of the unit, unsnapping the plastic fasteners, and remove front cover. Figure 1.
2. Remove the 3 screws securing the control panel and hinge the panel down. Figure 2.
3. Using a small screwdriver, press down on the wire retainers on the ends of the ballast and remove wires from ballast. Figure 3.
4. Remove screws securing the ends of the faulty ballast and remove ballast. Figure 4.
5. Install new ballast in reverse order. Use the color coded chart on the ends of the ballast on re-installing the wires.

**2-5. BASE HEATERS**



To avoid electrical shock or property damage, move the **POWER** switch to **OFF** and disconnect main circuit breaker, or unplug cord at wall receptacle.



**Figure 1**

**Checkout:**

1. Carefully pry out on the front cover of the unit, unsnapping the plastic fasteners, and remove front cover.
2. Remove the 3 screws securing the control panel and hinge the panel down.
3. Disconnect the wires from the heater terminals, and using a multimeter, or ohm meter, check ohm rating. Figure 1. The ohm ratings should be:

- HEC-103 - 208V - Cold - 39 ohms**
- HEC-103 - 240V - Cold - 52 ohms**
- HEC-104 - 208V - Cold - 49 ohms**
- HEC-104 - 240V - Cold - 70 ohms**

**Replacement:**

4. If heater proves faulty, remove the well covers.
5. Remove the screws securing the heater to the unit and pull the heater from the unit. Figure 2.
6. Install new heater in reverse order.

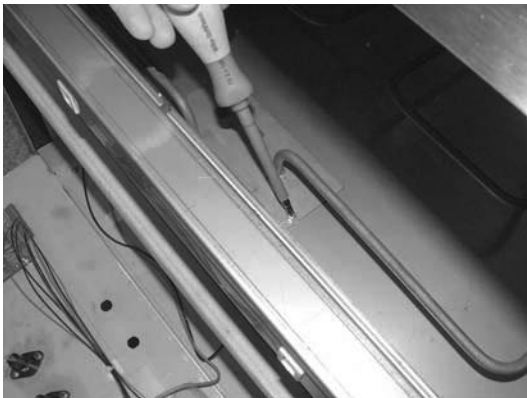

**Figure 2**

**2-6. TRANSFORMERS**



To avoid electrical shock or property damage, move the **POWER** switch to **OFF** and disconnect main circuit breaker, or unplug cord at wall receptacle.

**Checkout:**

1. Carefully pry out on the front cover of the unit, unsnapping the plastic fasteners, and remove front cover.
2. Remove the 3 screws securing the control panel and hinge the panel down.

## 2-6. TRANSFORMERS (Continued)

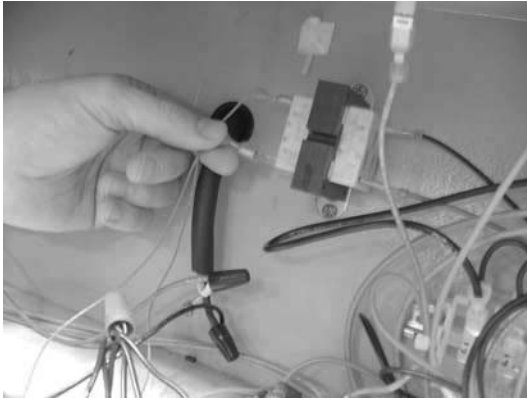

**Figure 1**

3. Label and disconnect the wires from the transformer terminals, and using a multimeter, or ohm meter, check ohm rating. Figure 1. The ohm ratings should be:

**Secondary: 1 ohm**  
**Primary: 234 ohms - 208V**  
**200 ohms - 240V**

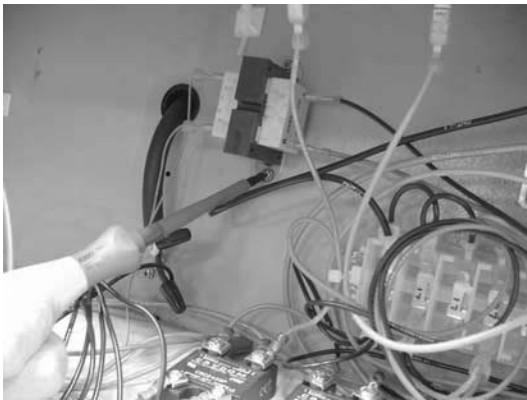

**Figure 2**

### **Replacement:**

4. If transformer proves faulty, remove screws securing transformer to the unit and remove transformer. Figure 2.

5. Install new transformer in reverse order.

## 2-7. RELAYS



**To avoid electrical shock or property damage, move the POWER switch to OFF and disconnect main circuit breaker, or unplug cord at wall receptacle.**

### **Checkout:**

1. Carefully pry out on the front cover of the unit, unsnapping the plastic fasteners, and remove front cover.
2. Remove the 3 screws securing the control panel and hinge the panel down.

**2-7. RELAYS (Continued)**



To avoid electrical shock, make connections before applying power, take reading, and remove power before removing meter leads. The following checks are performed with the wall circuit breaker closed and the main power switch in the ON position.

3. With power reapplied, let unit start heating up, and with the component energized, 0 volts should show on the output side of the relay, and 12 volts on the input.
4. If voltage varies from steps 4 and 5, remove power to unit, pull input wires from relay and place leads of meter onto input wires. Reapply power to unit. If the input wires to relay shows 12 vdc volts, the relay is faulty.

**Replacement:**



**Figure 1**

5. Label and remove the wires from the relay, using a Phillip's head screwdriver. Figure 1.
6. Using a Phillip's head screwdriver, remove the 2 screws securing the relay and remove faulty relay. Figure 2.



**Figure 2**

7. Install new relay in reverse order.

## **2-8. FUSE AND FUSE HOLDER REPLACEMENT**



**To avoid electrical shock or property damage, move the POWER switch to OFF and disconnect main circuit breaker, or unplug cord at wall receptacle.**



**Figure 1**

### **Fuse Replacement:**

1. Carefully pry out on the front cover of the unit, unsnapping the plastic fasteners, and remove front cover.
2. Unscrew fuse holder cap counterclockwise to access fuse. Figure 1.

To check fuse, use a multimeter, or continuity tester, and put leads on each end of fuse. If meter shows circuit is closed, fuse is good. Replace fuse with a 15 amp fuse, (20 amp fuse-CE), if meter shows circuit is open.



**Figure 2**

### **Fuse Holder Replacement:**

1. With the front cover removed, remove the 3 screws securing the control panel and hinge the panel down.
2. Label wires and pull wires from the terminals of the faulty fuse holder. Figure 2.

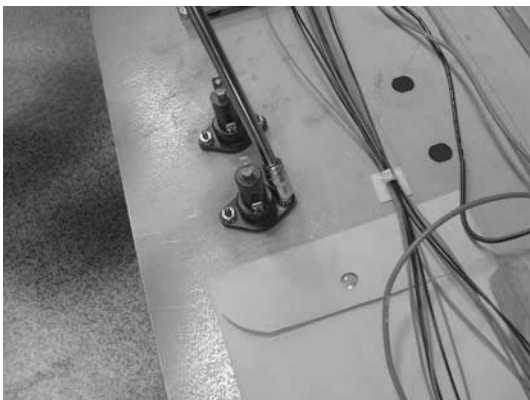

**Figure 3**

3. Remove the nuts securing the fuse holder and pull the fuse holder from the unit. Figure 3.
4. Replace with new fuse holder in reverse order.

## **2-9. POWER SWITCH REPLACEMENT**



**Figure 1**



**Figure 2**

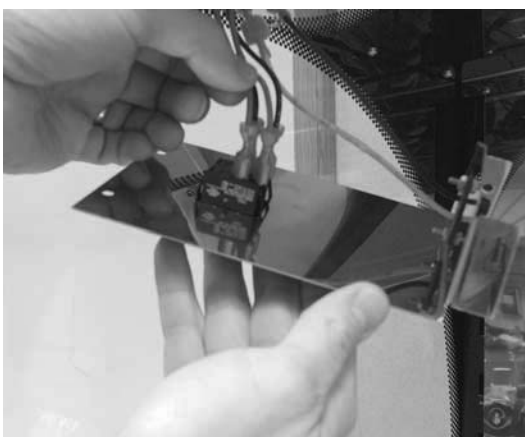

**Figure 3**



**To avoid electrical shock or property damage, move the POWER switch to OFF and disconnect main circuit breaker, or unplug cord at wall receptacle.**

1. Remove the screws securing the fluorescent bulb guards on both ends of the bulb, and remove guards. Figure 1.
2. Twist bulb and remove from canopy.
3. Using a Phillip's head screwdriver, remove the screws securing the POWER switch plate, and pull plate down from canopy. Figure 2.
3. Label and remove wires from POWER switch. Figure 3.
4. Pushing in on the tabs on the sides of the POWER switch, push switch through, to the outside of the plate, and then replace with new switch in reverse order. Figure 4.



**Figure 4**



## 2-10. CONTACTOR REPLACEMENT

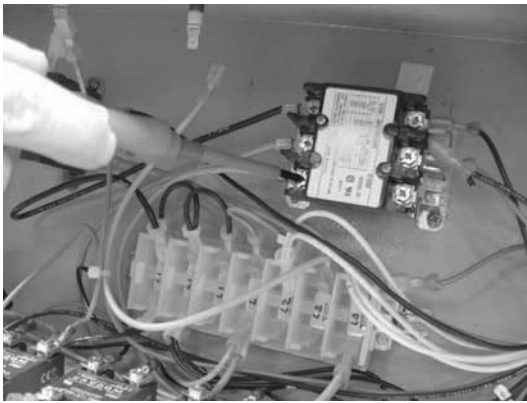

**Figure 1**



**Figure 2**

## 2-11. PC BOARD REPLACEMENT



**To avoid electrical shock or property damage, move the POWER switch to OFF and disconnect main circuit breaker, or unplug cord at wall receptacle.**

1. Carefully pry out on the front cover of the unit, unsnapping the plastic fasteners, and remove front cover.
2. Remove the 3 screws securing the control panel and hinge the panel down.
3. Label and disconnect the wires from the contactor coil, and using a multimeter or ohm meter check ohm rating. The ohm rating should be 540 ohms.
4. If contactor proves faulty, remove screws securing the wires to the contactor. Figure 1.
5. Using a Phillip's head screwdriver, remove the screws securing the relay and remove faulty contactor. Figure 2
6. Install new contactor in reverse order.



**To avoid electrical shock or property damage, move the POWER switch to OFF and disconnect main circuit breaker, or unplug cord at wall receptacle.**

1. Carefully pry out on the front cover of the unit, unsnapping the plastic fasteners, and remove front cover.
2. Remove the 3 screws securing the control panel and hinge the panel down.

## **2-11. PC BOARD REPLACEMENT** **(Continued)**

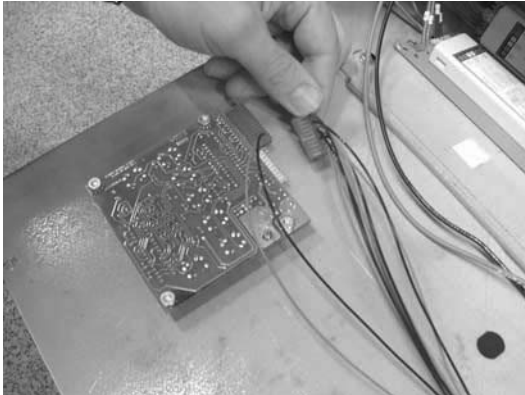

**Figure 1**

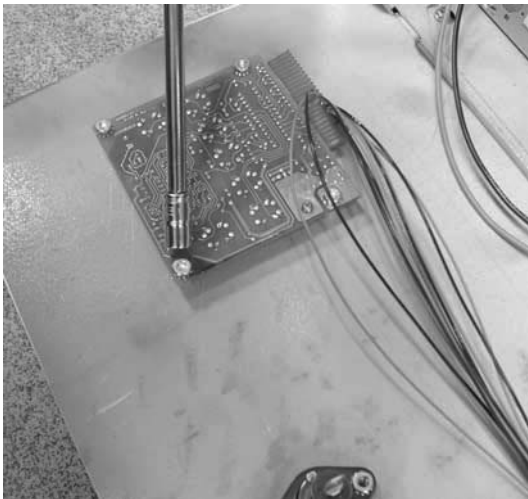

**Figure 2**

- 3.. Remove connectors to the PC board. Figure 1.
  
4. Using a 5/16 in. socket, remove teh nuts securing the PC board to the panel. Figure 2.
  
5. Install new PC board in reverse order.

### **NOTICE**

When installing new PC board, make sure the spacers are placed on the mounting studs before the PC board in mounted on them. Without the spacers, the PC board could be over-tightened and causing the buttons to stick.

## **2-12. HEATED SHELF REPLACEMENT**

The heated shelves must be replaced if heaters inside the shelves are faulty. See steps below on replacing shelves.



**To avoid electrical shock or property damage, move the POWER switch to OFF and disconnect main circuit breaker, or unplug cord at wall receptacle.**

**To avoid burns, allow the unit to cool before servicing.**

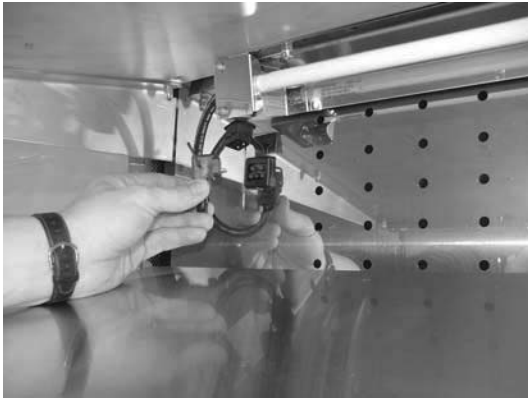
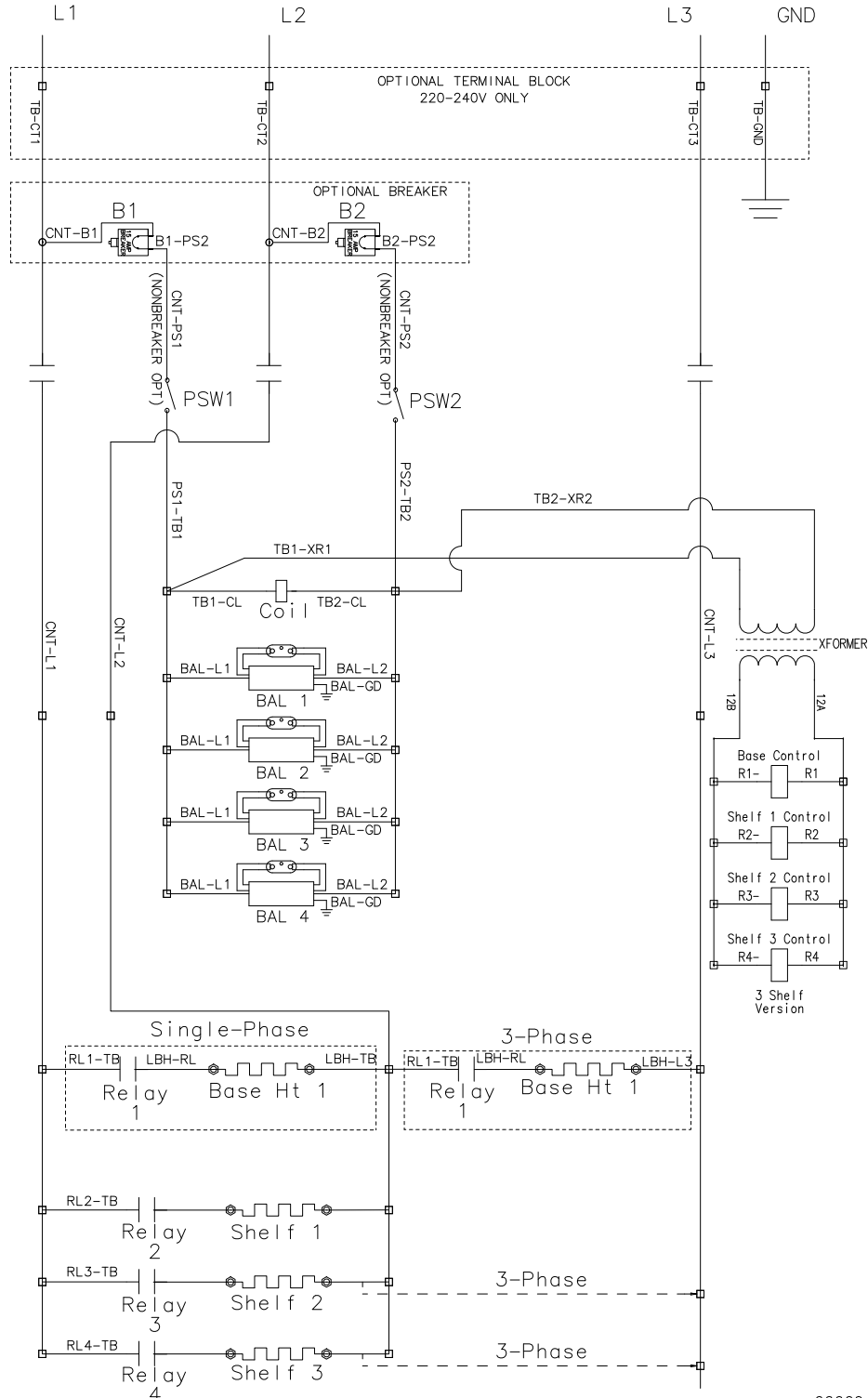

**Figure 1**

1. Unplug both sides of the shelf. Figure 1.
2. Lift shelf from unit.
3. Using a multimeter or ohm meter check ohm rating of the shelf at the right-hand cord and plug assembly. The ohm rating should be around 80 ohms.
4. If shelf heaters are faulty, twist bulb and remove from shelf.
5. Remove the 4 acorn nuts securing the lamp fixture to the shelf and remove the fixture.
6. Install the light fixture to the new shelf.
7. Install flourescent bulb back into fixture and place new shelf back into the unit.



HEC-103 3-SHELF  
1PH OR 3PH  
208/240V; 220-240V



66660

**66660**



HEC103 3-SHELF  
208, 240, 220-240V 3PH

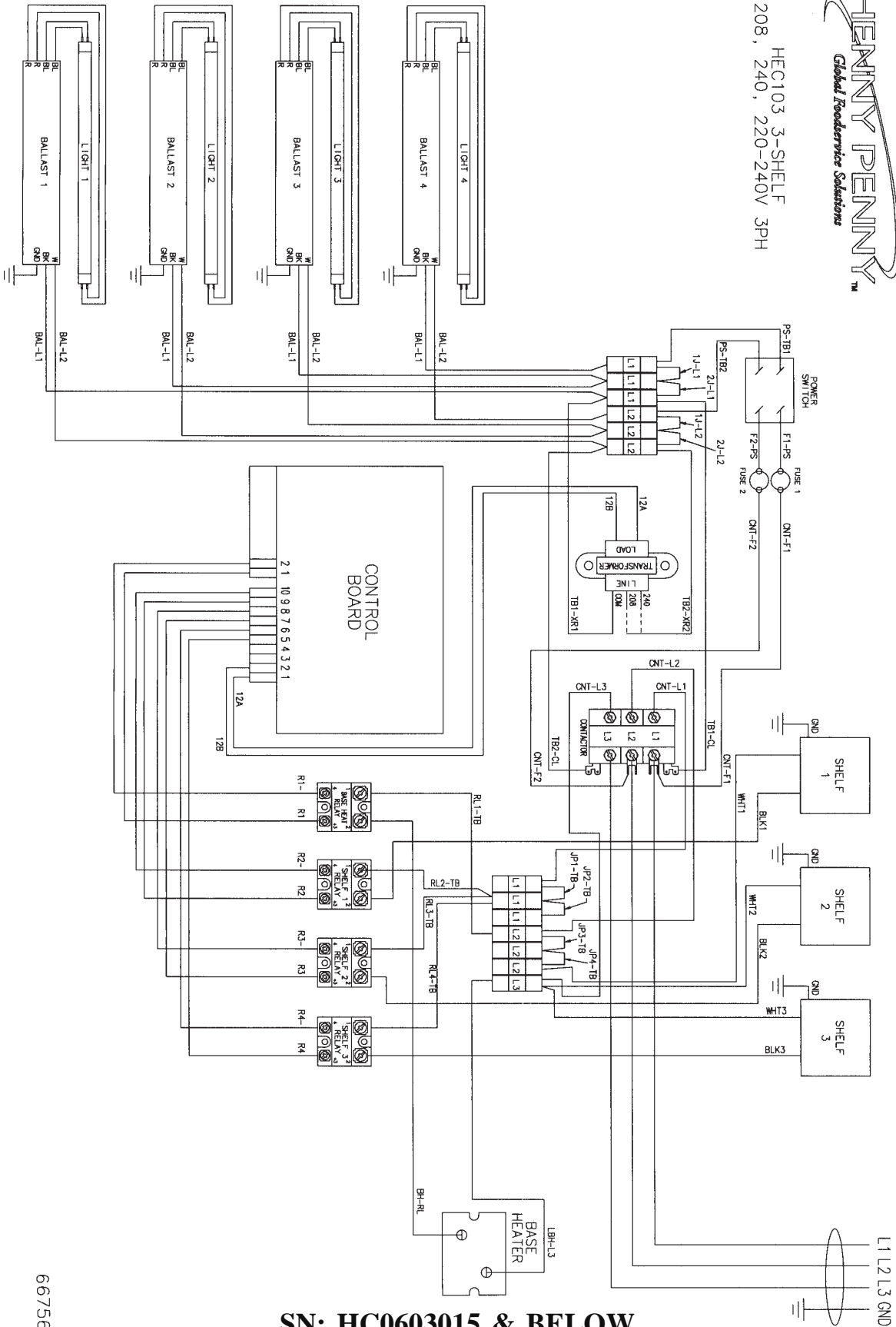

SN: HC0603015 & BELOW

66756

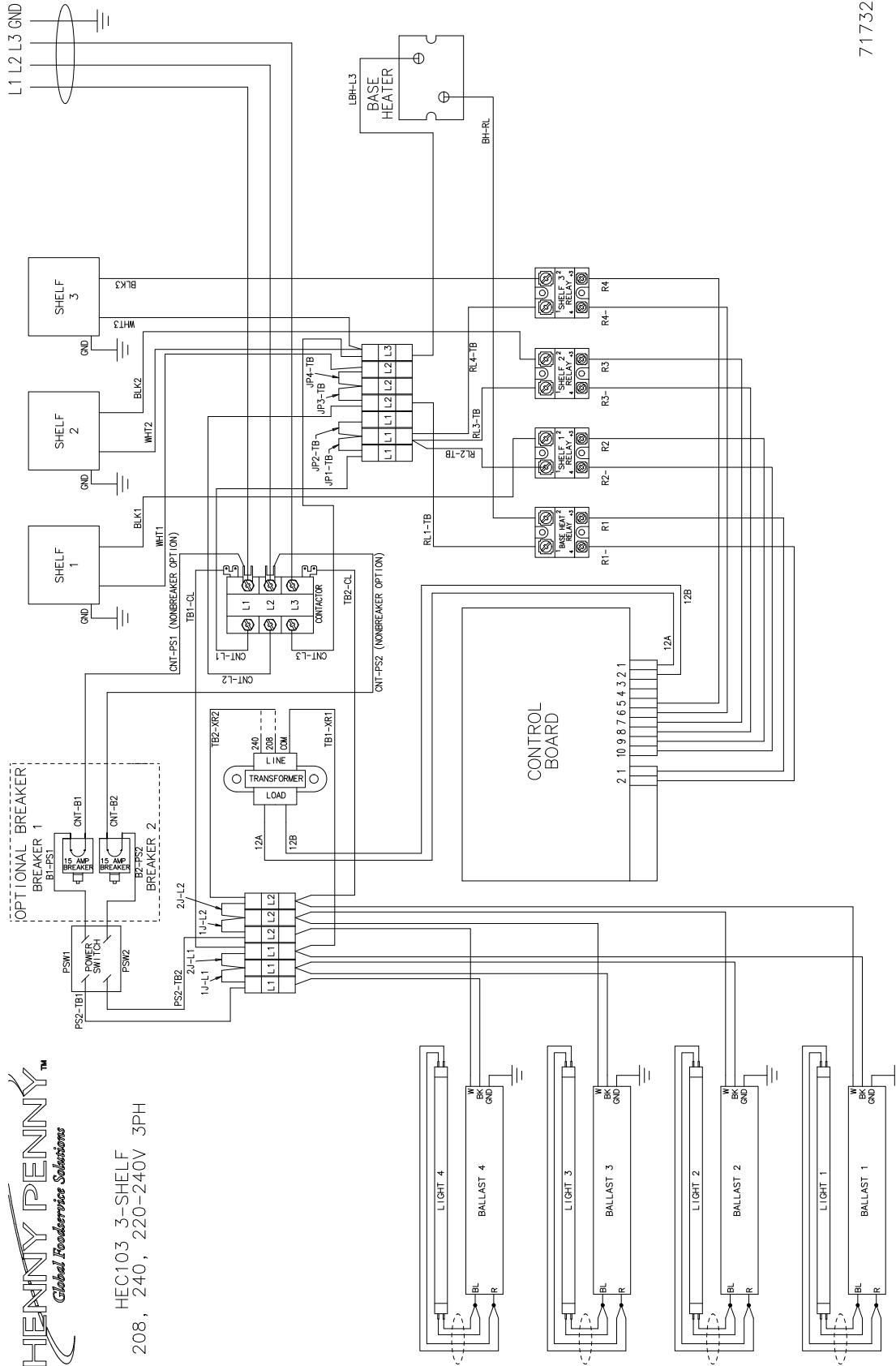

71732



HEC103 3-SHELF  
208, 240, 220-240V 3PH

**SN: HC0603016 & ABOVE**



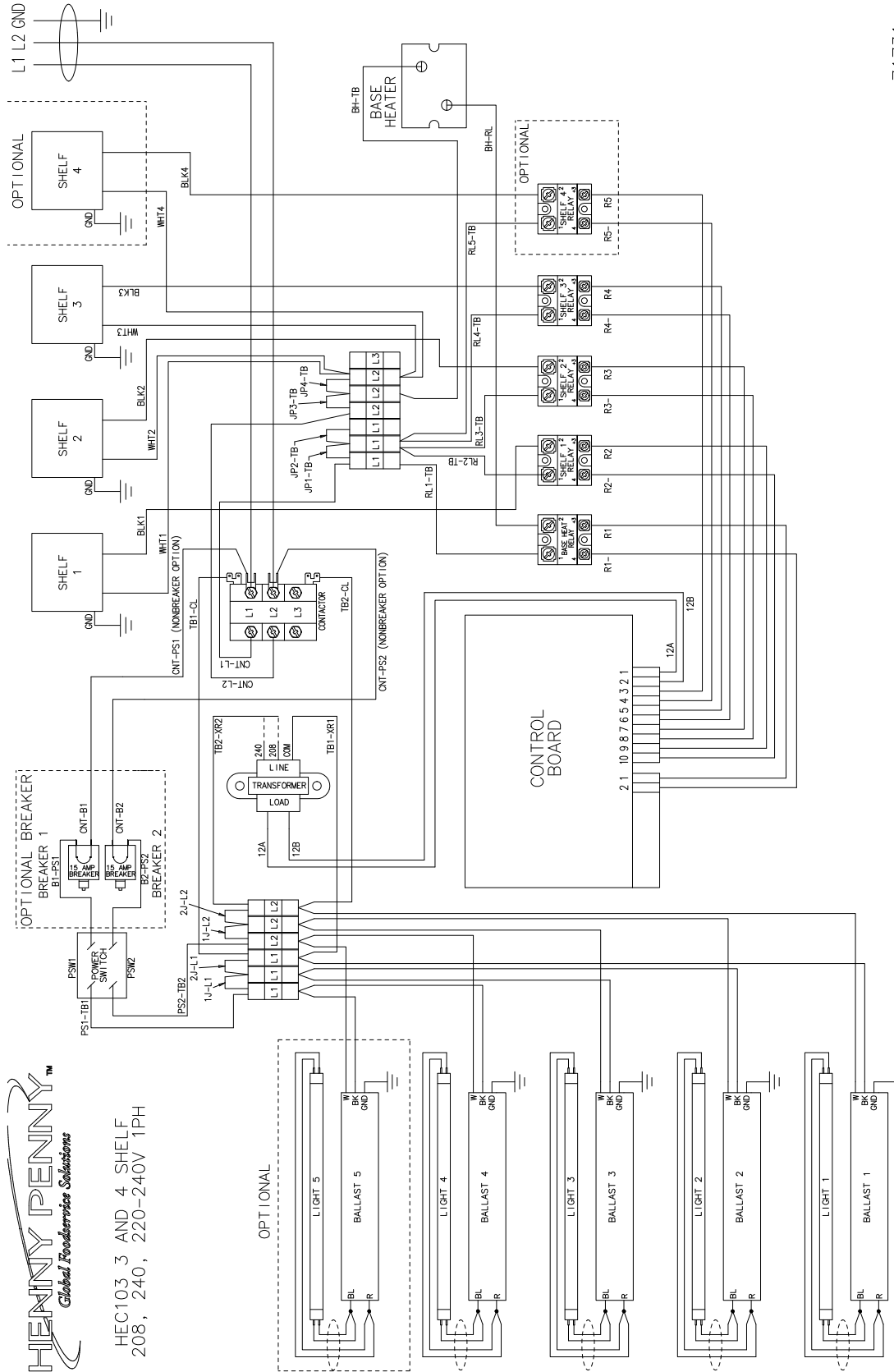

71731

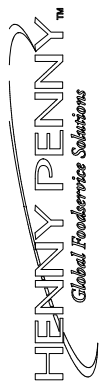

HEC103 3 AND 4 SHELF  
208, 240, 220-240V 1PH

**SN: HC0603016 & ABOVE**





HEC-103 4-SHELF  
1PH OR 3PH  
208/240V; 220-240V

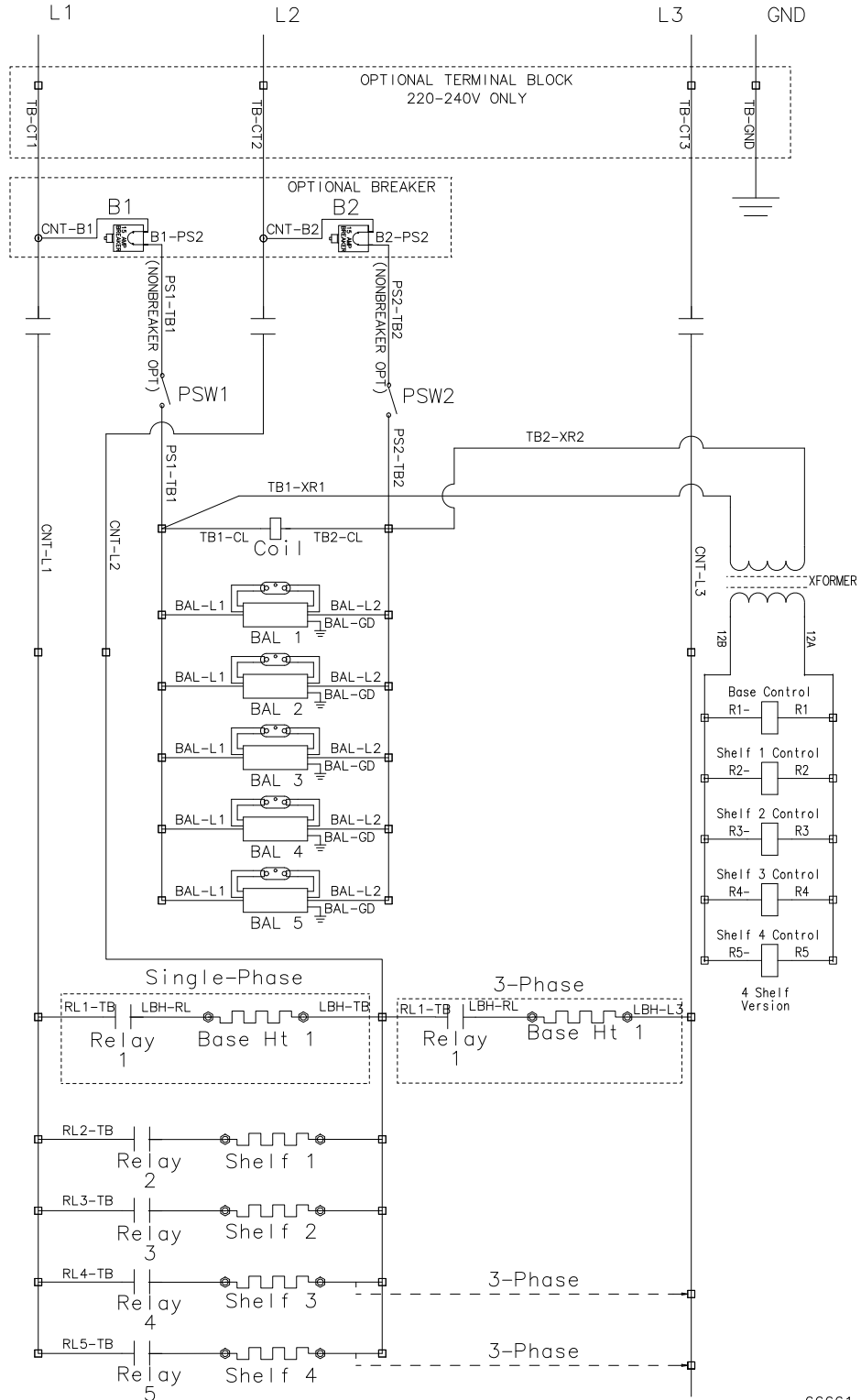

66661

**66661**



HEC103 4-SHELF  
208, 240, 220-240V 3PH

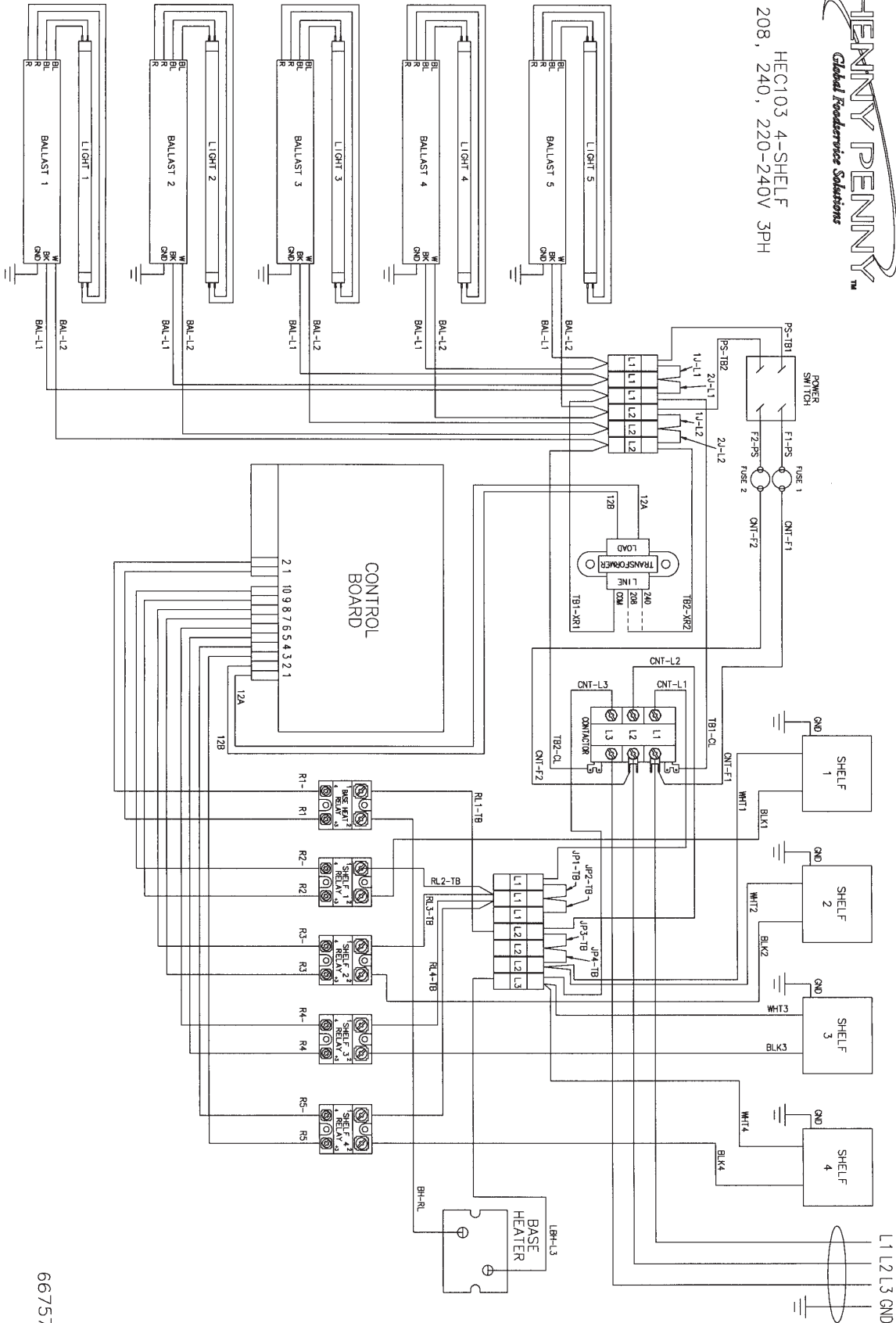

66757

SN: HC0603015 & BELOW

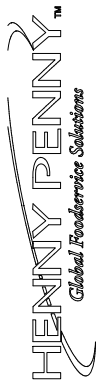
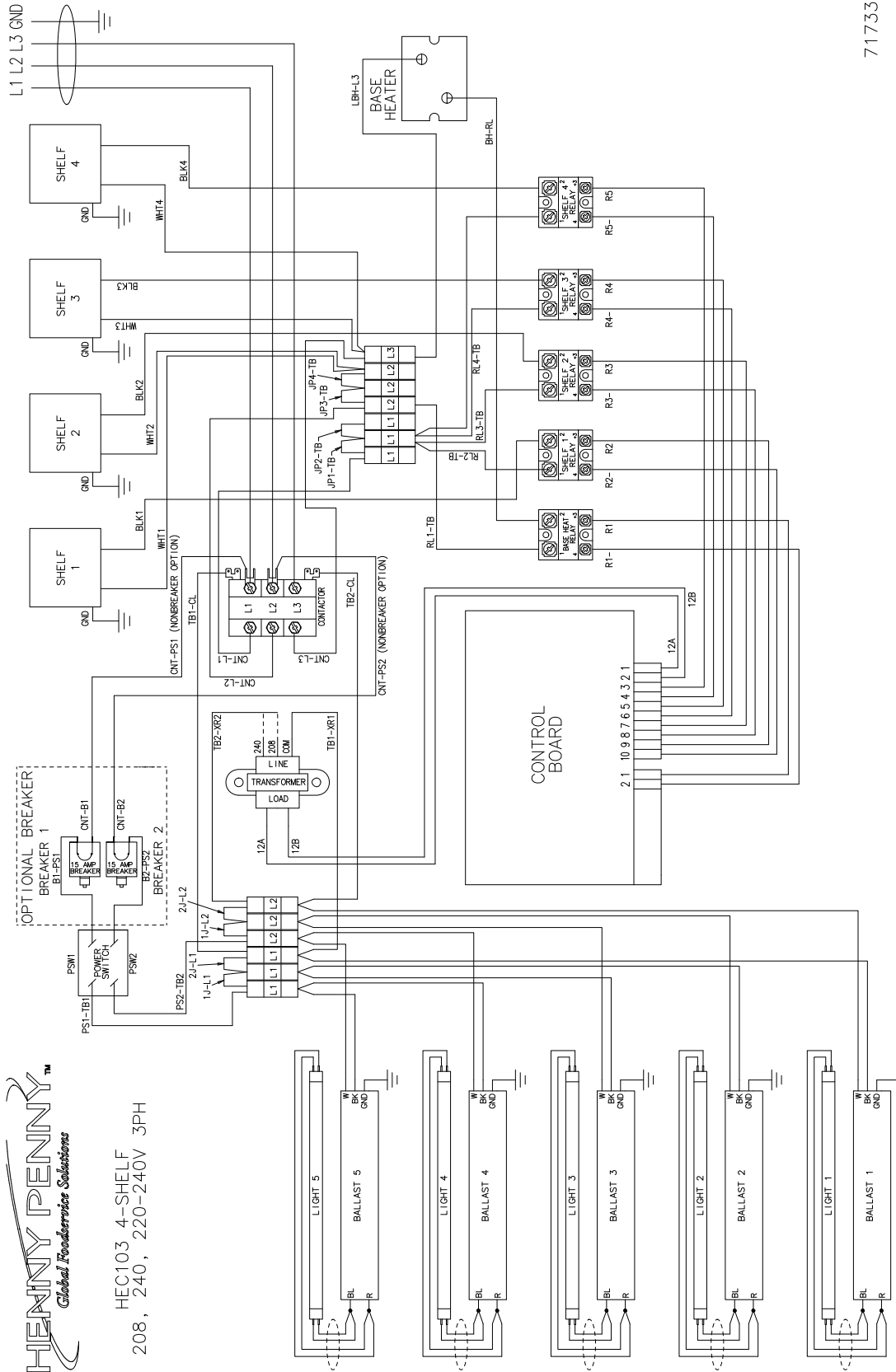

HEC103 4-SHELF  
208, 240, 220-240V 3PH

**SN: HC0603016 & ABOVE**

71733



HEC-103 3-SHELF/4-SHELF  
230V/1PH

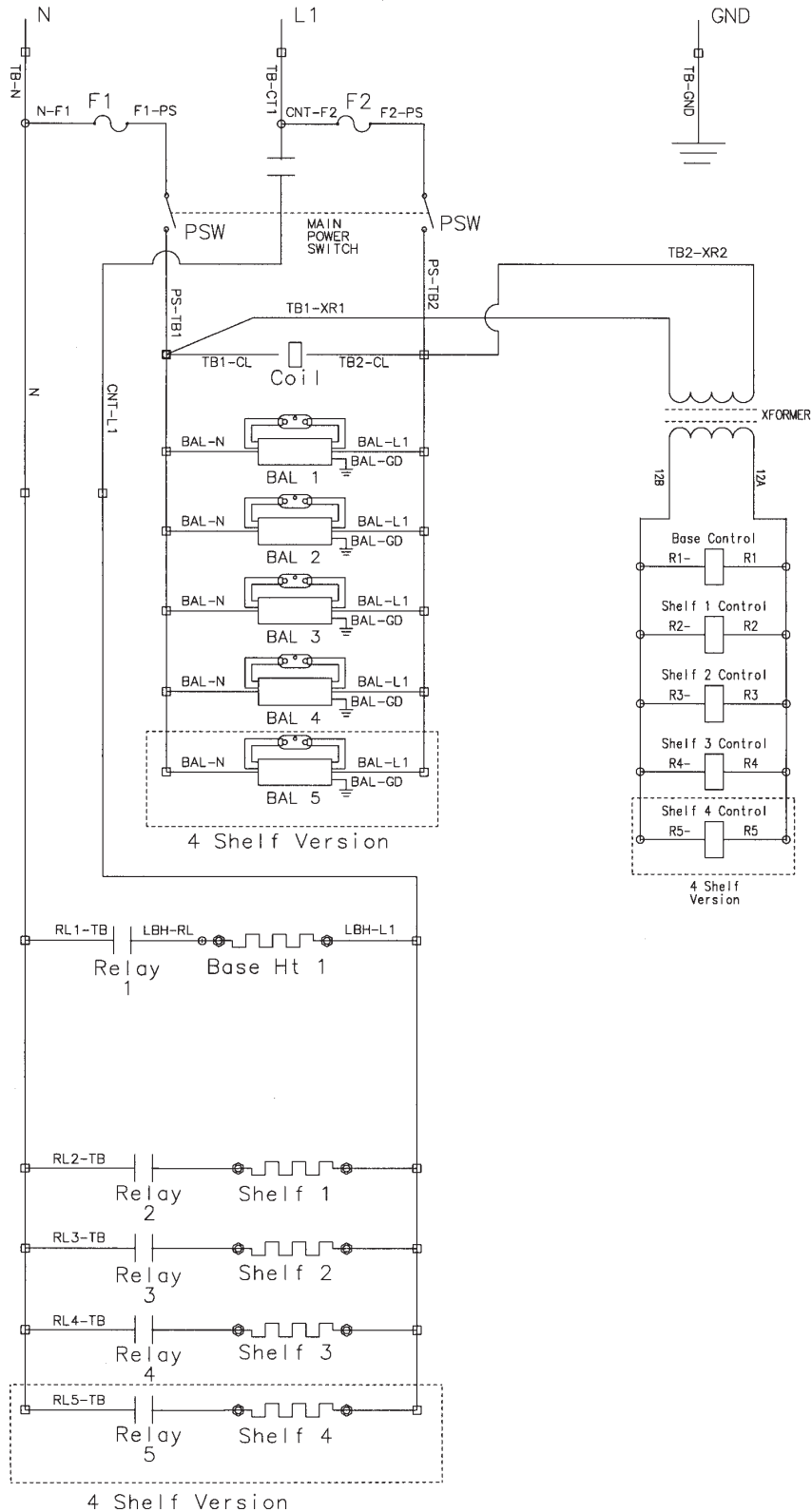

66845



**HEC103 3 AND 4 SHELF  
230V 1PH**

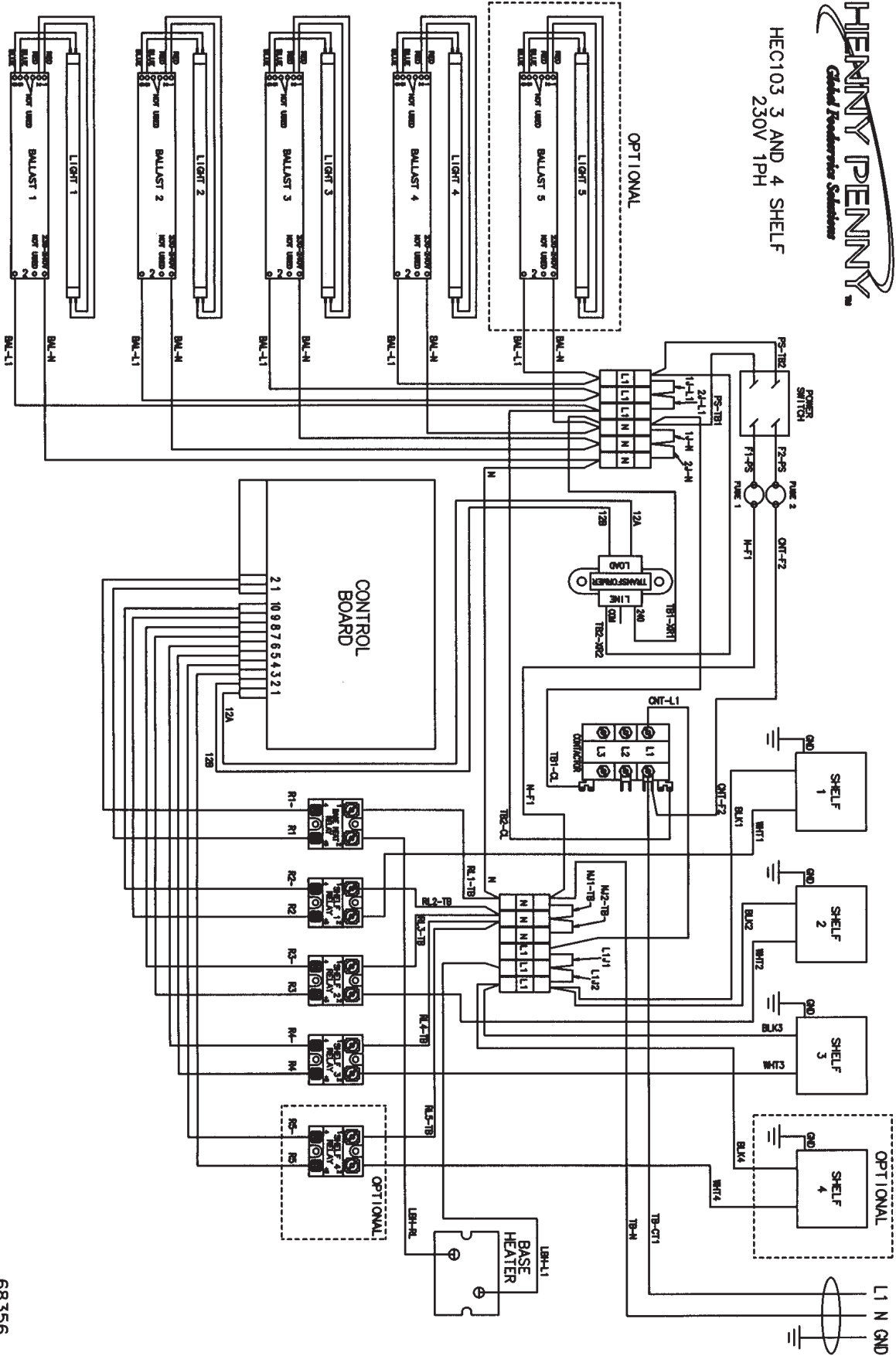

**SN: HC0708011 & BELOW**

68356

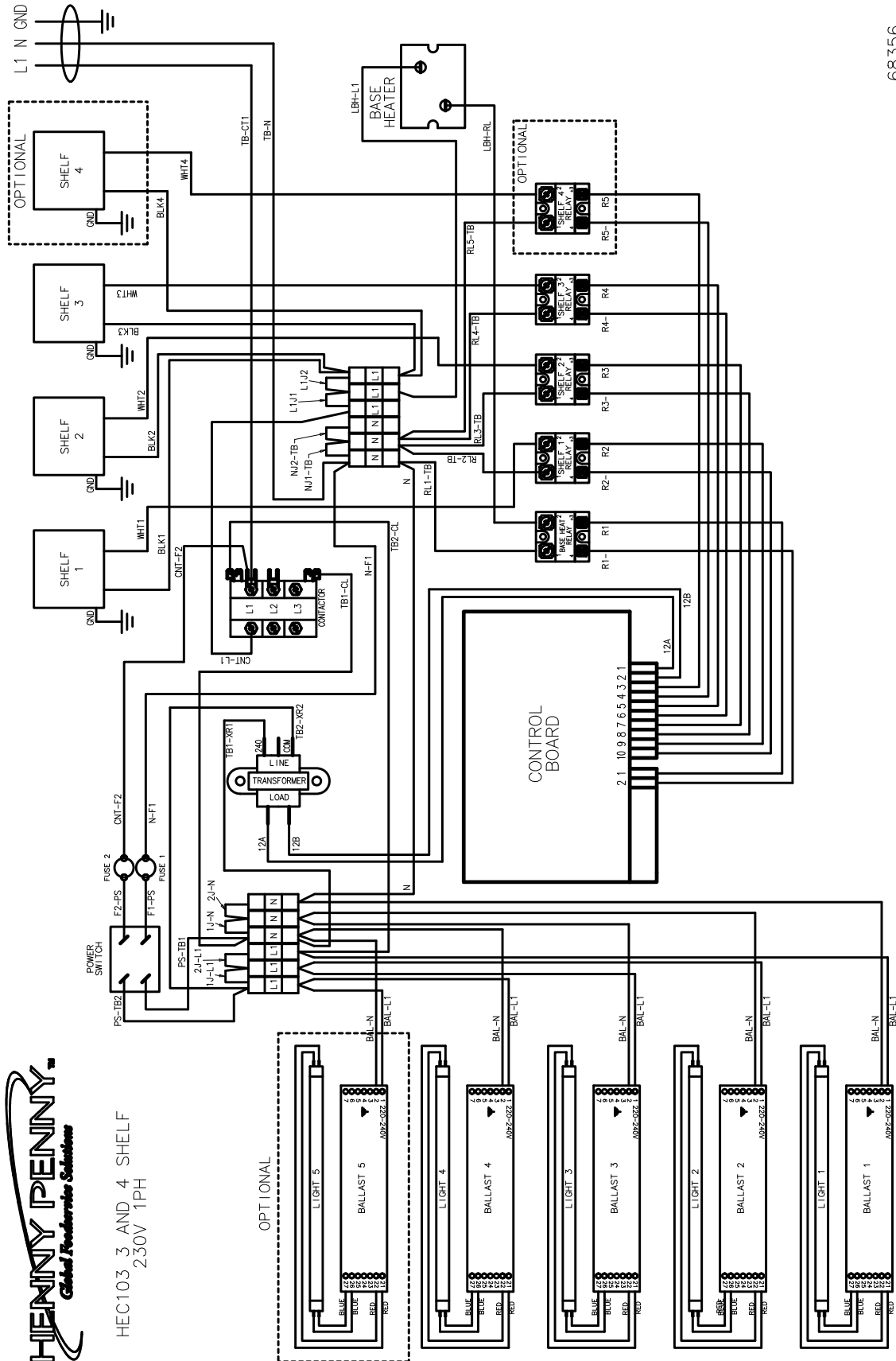

68356

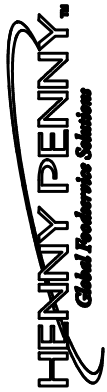

HEC103, 3 AND 4 SHELF  
230V 1PH

SN: HC0708012 & ABOVE



HEC-103 3-SHELF/4-SHELF  
380-415V/3PH

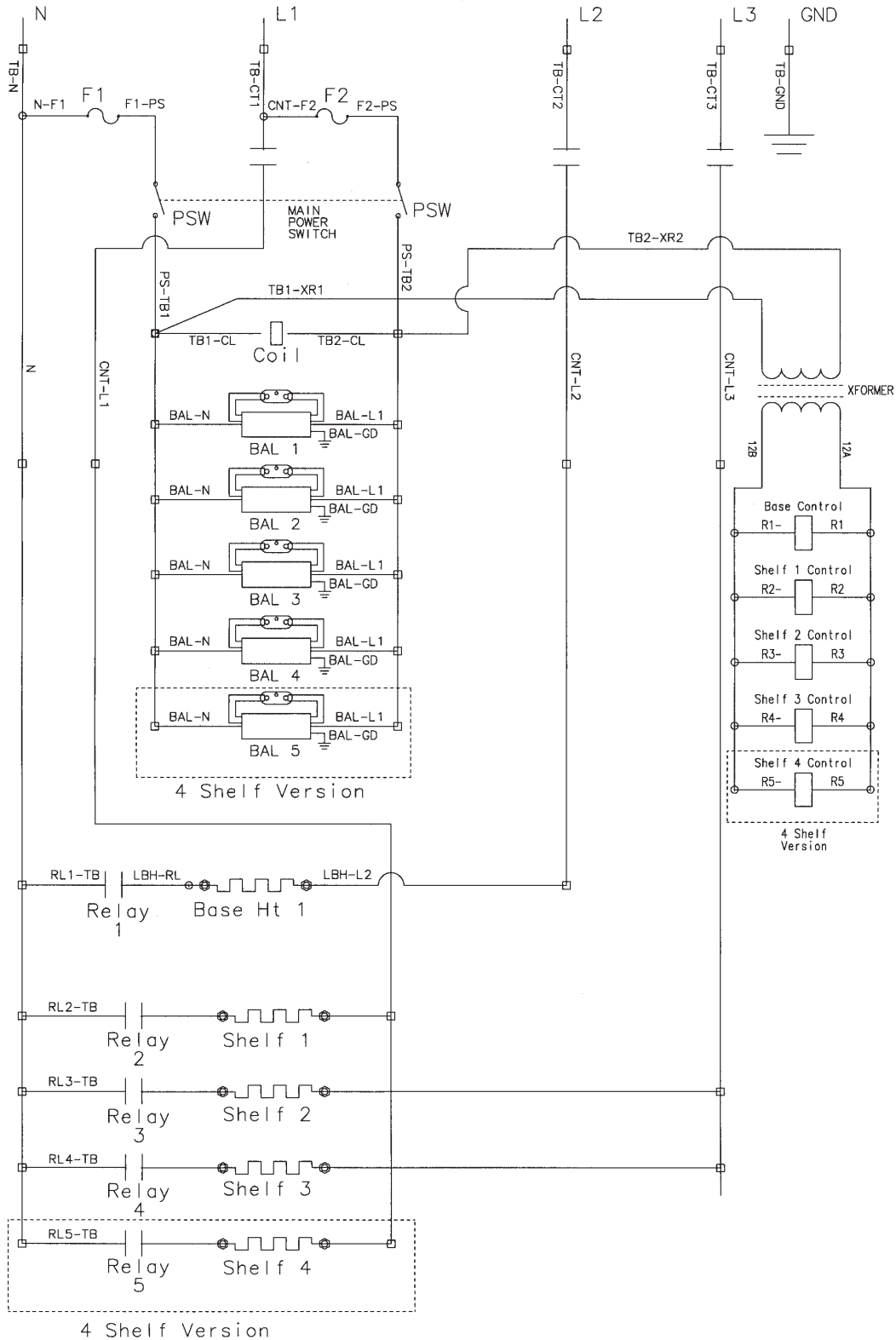

66830



HEC-104 3-SHELF/4-SHELF  
1PH OR 3PH  
208/240V; 220-240V

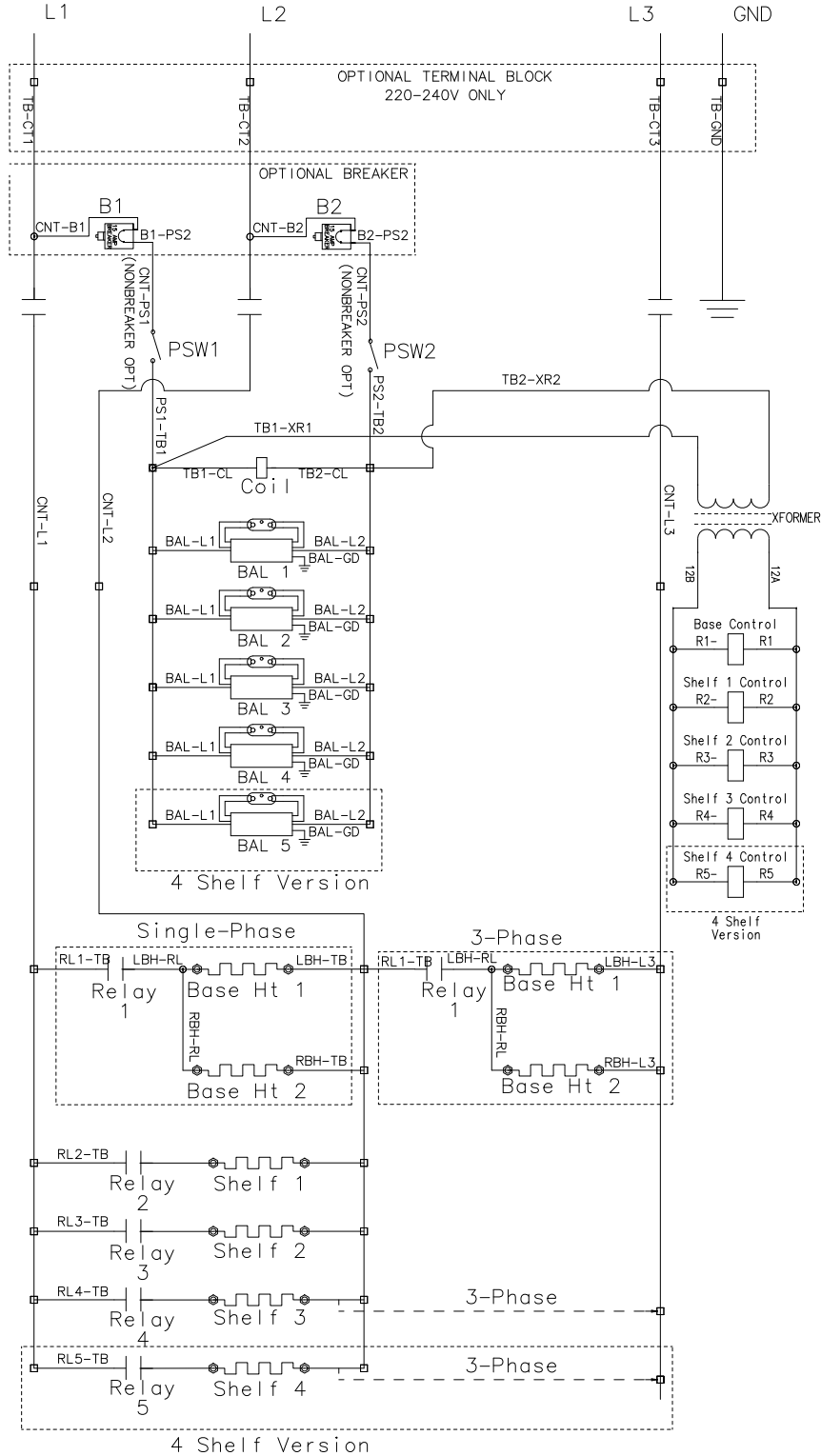

66060





HEC104 3 AND 4 SHELF  
208, 240, 220-240V 3PH

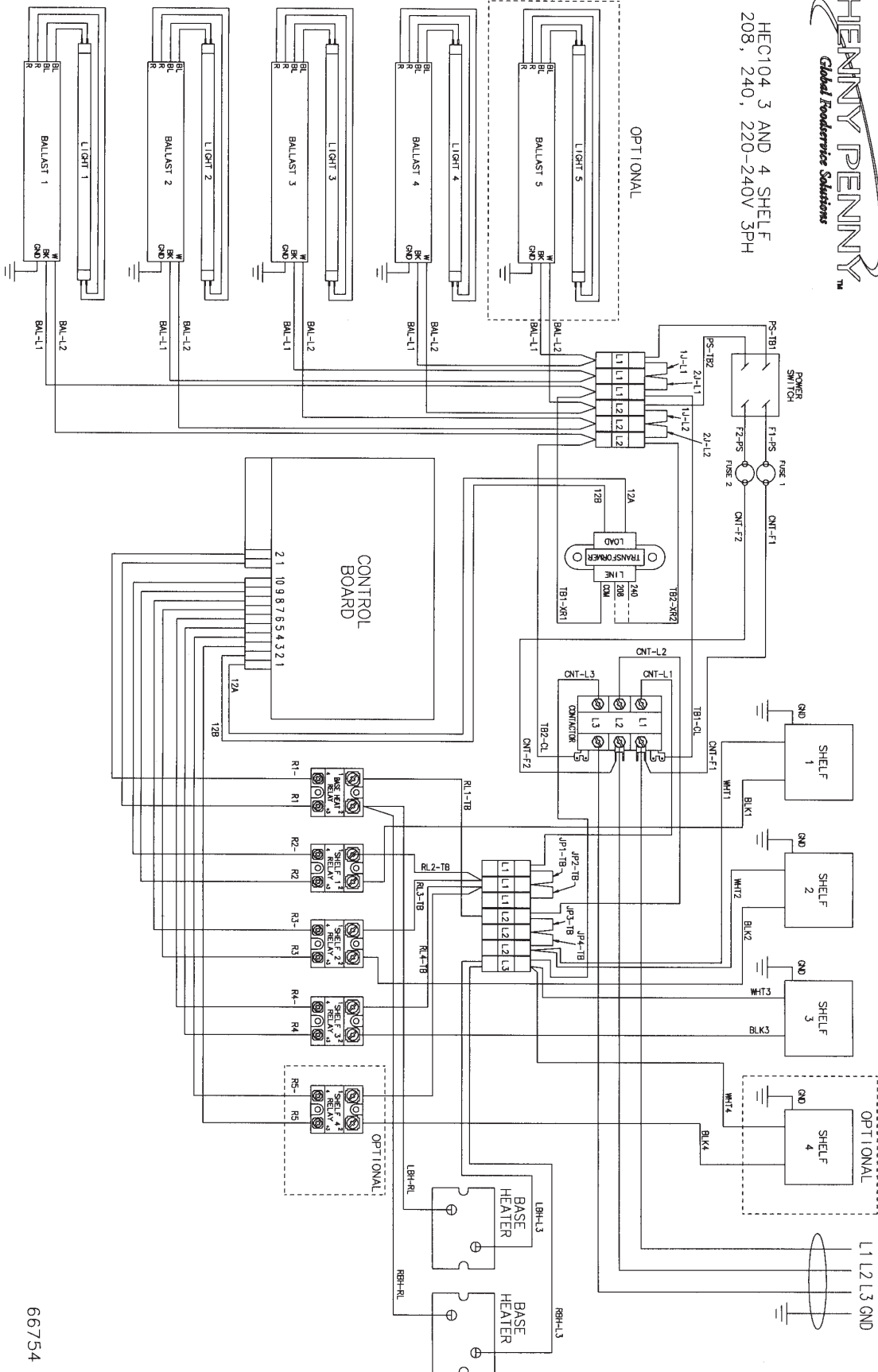

SN: HC0603013 & BELOW

66754

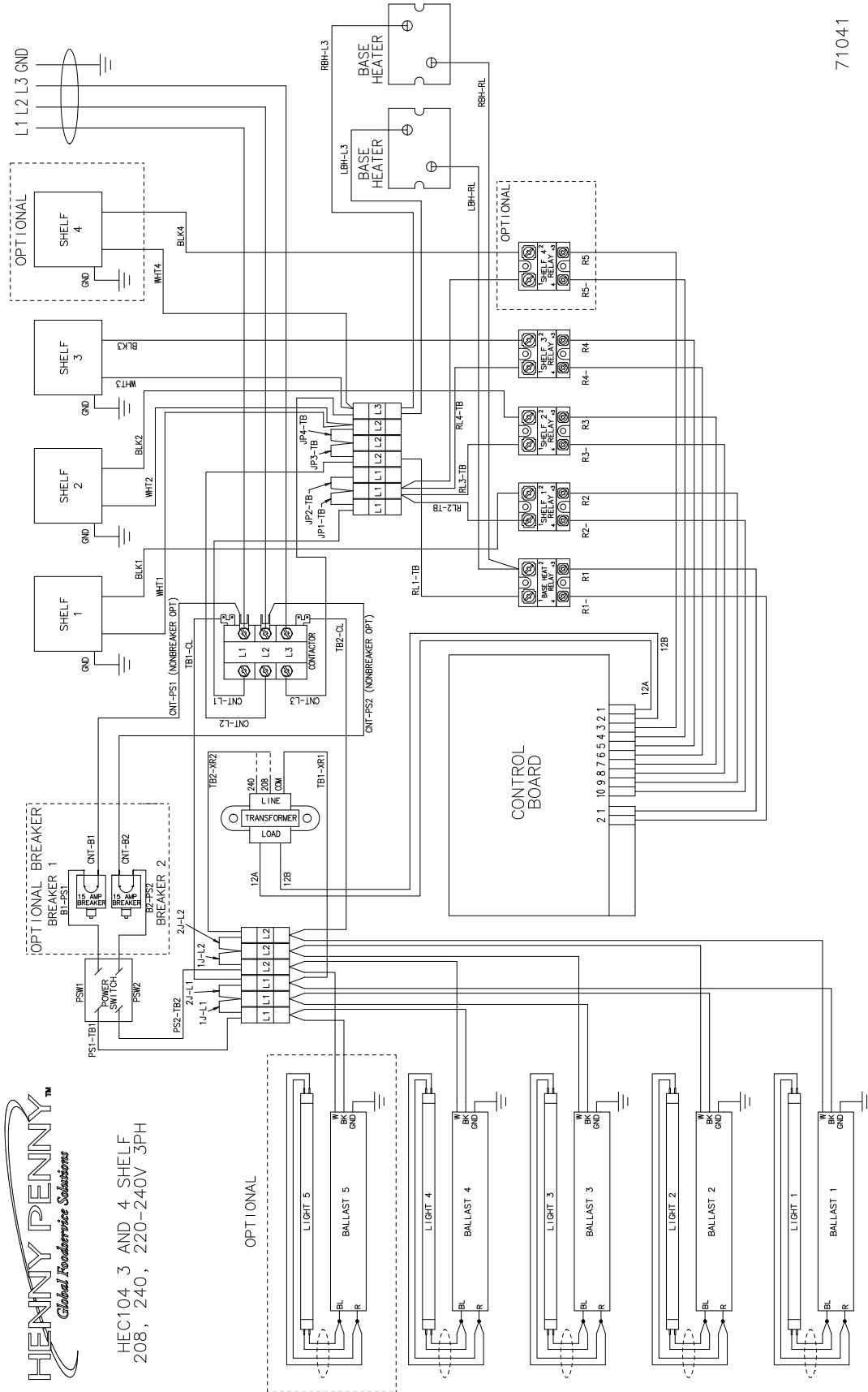

71041

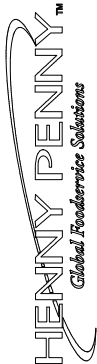

HEC104.3 AND 4 SHELF  
208, 240, 220-240V 3PH

**SN: HC0603014 & ABOVE**



HEC104 3 AND 4 SHELF  
208, 240, 220-240V 1PH

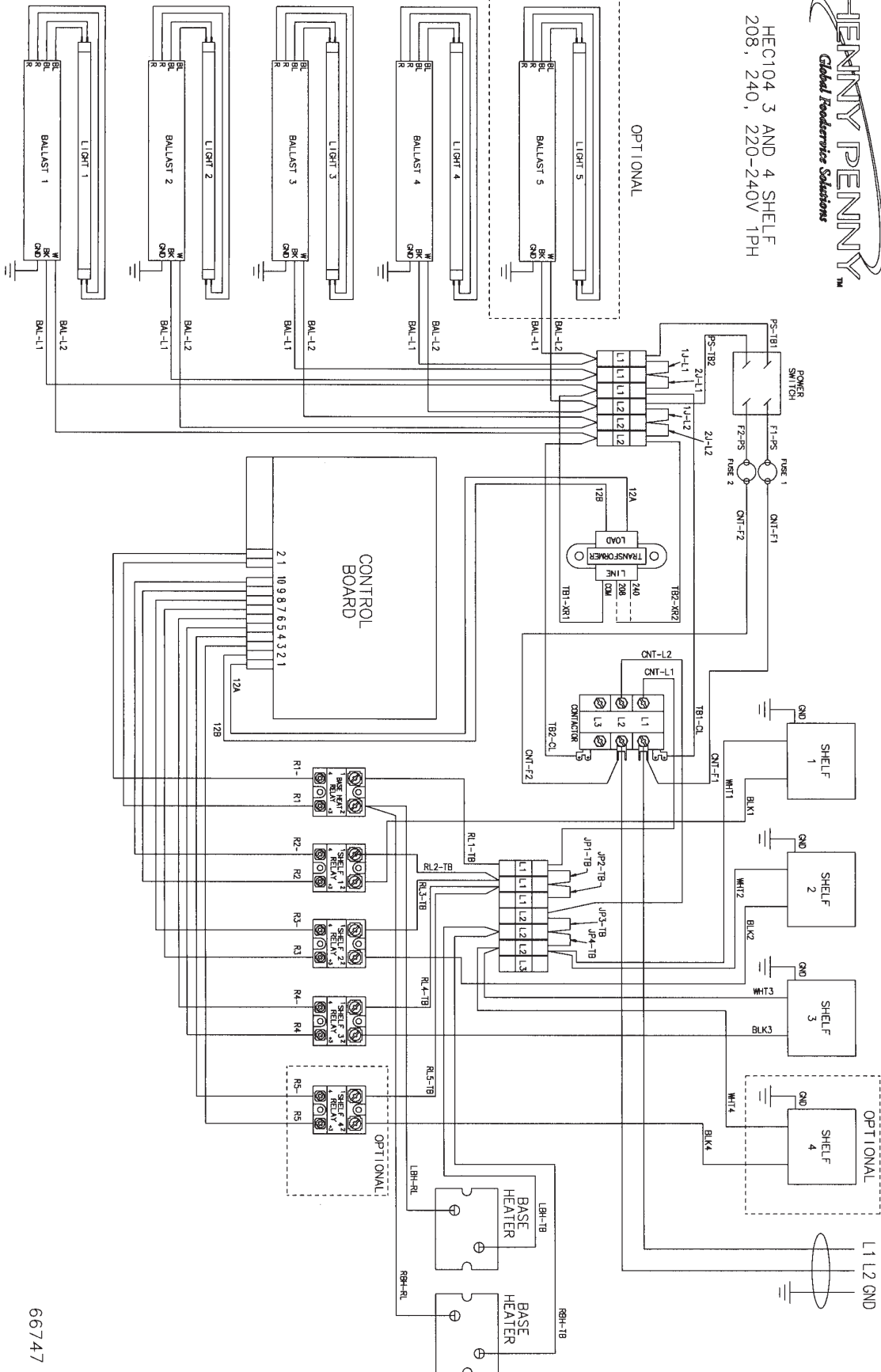

66747

SN: HC0603013 & BELOW

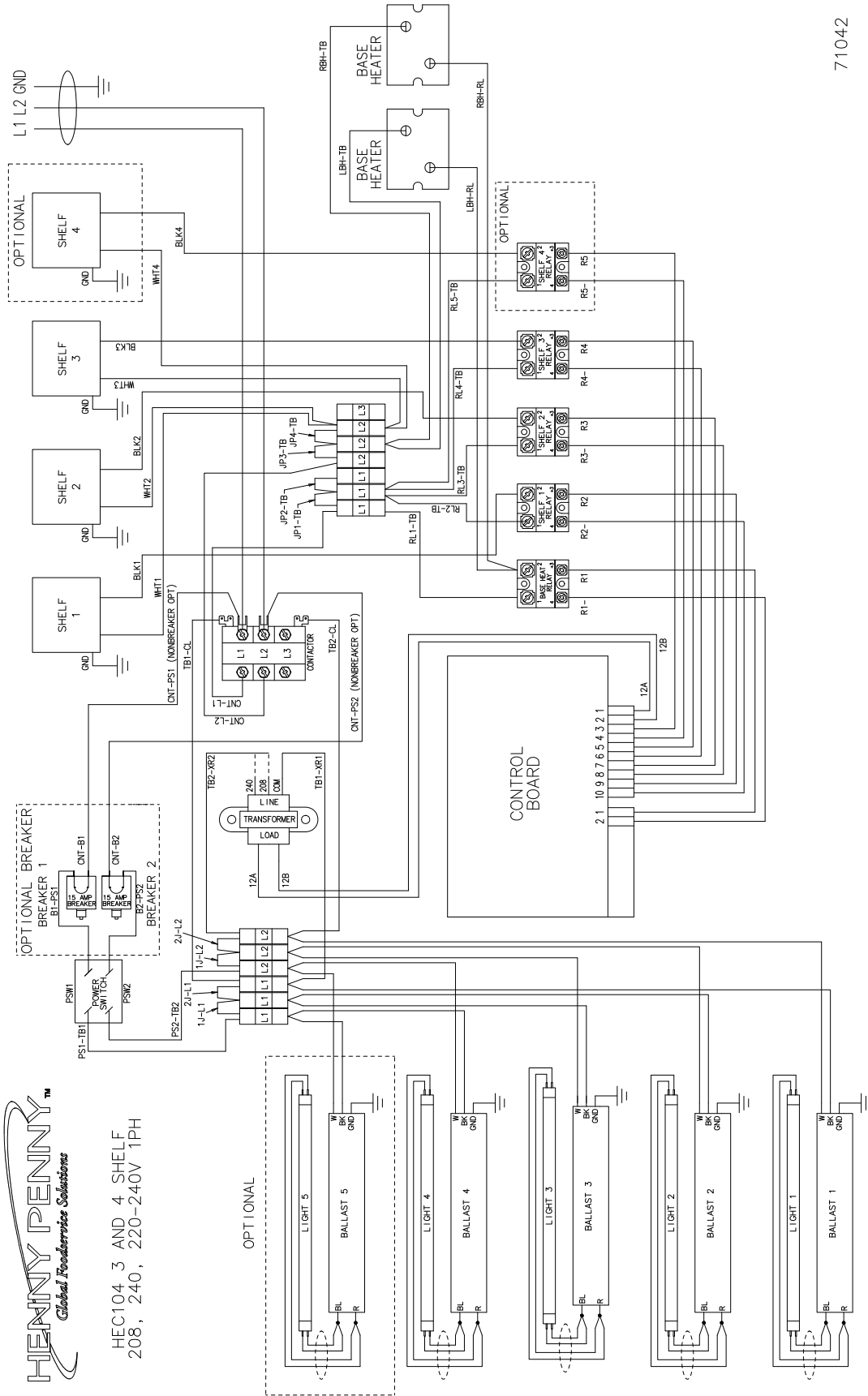

71042

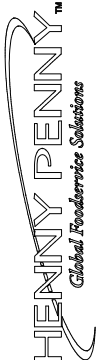

HEC104.3 AND 4 SHELF  
208, 240, 220-240V 1PH

**SN: HC0603014 & ABOVE**



HEC-104 3-SHELF/4-SHELF  
380-415V/3PH

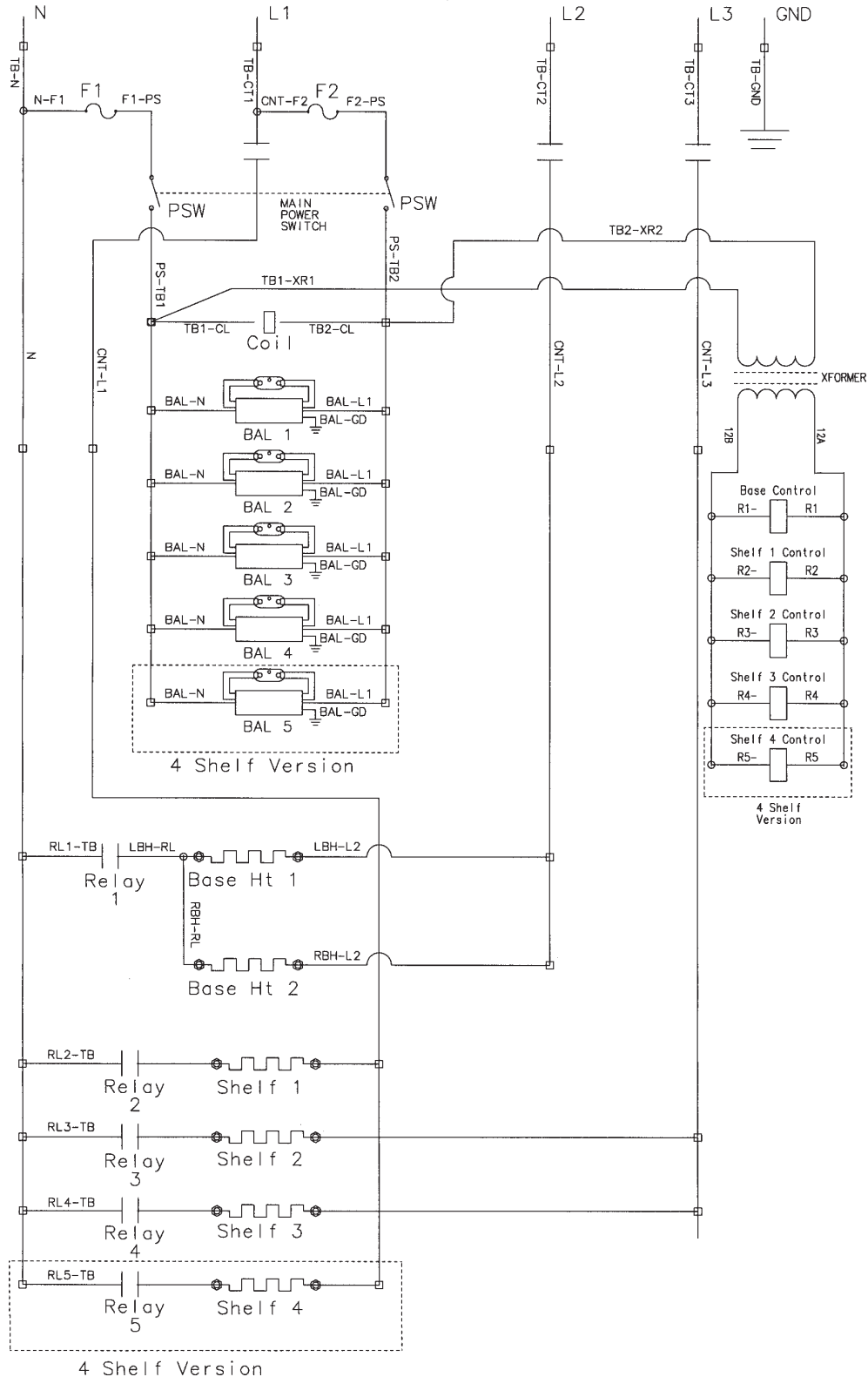

66812



HEC103/104 3 AND 4 SHELF  
380-415V 3PH

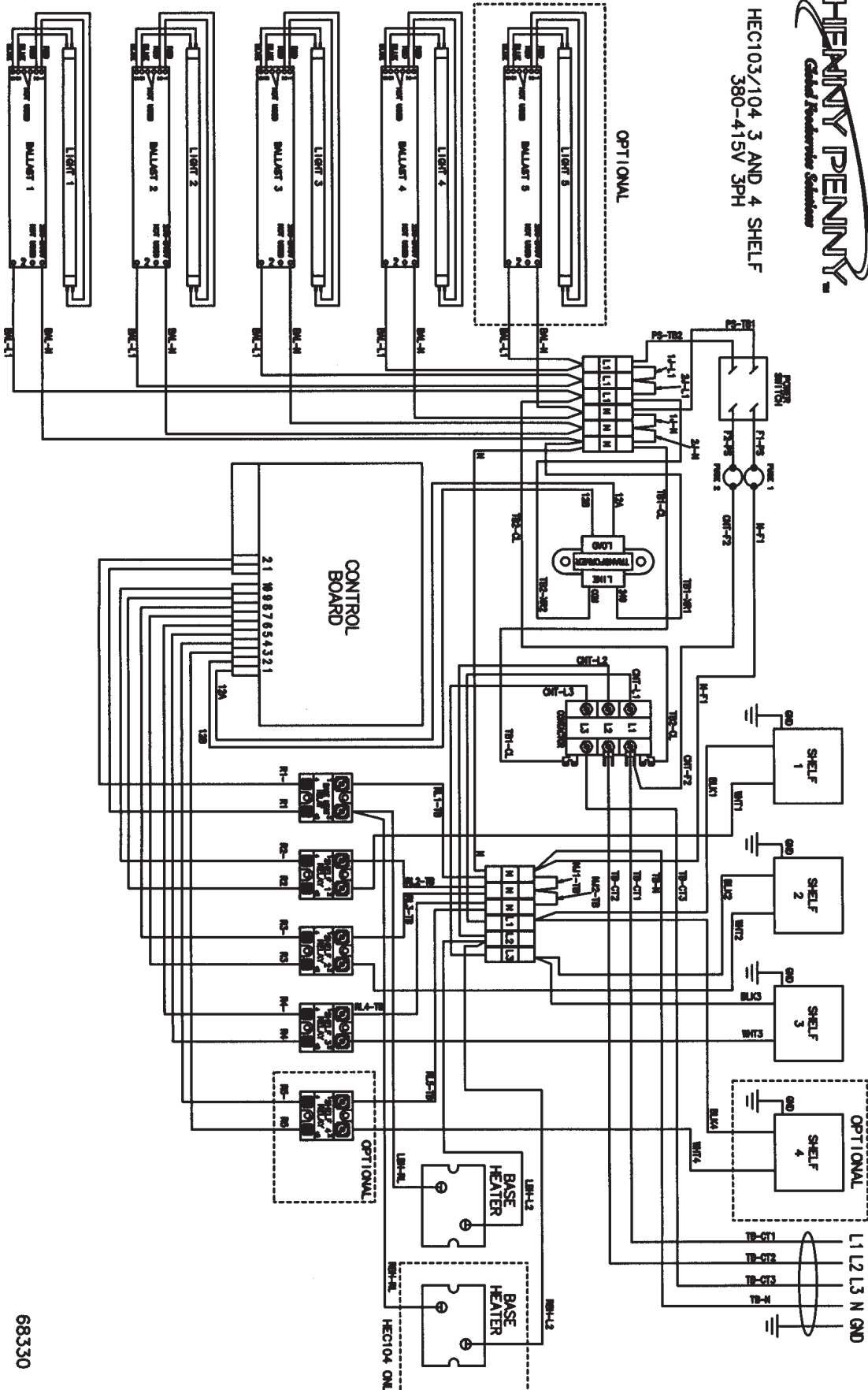

68330

SN: HC0708011 & BELOW

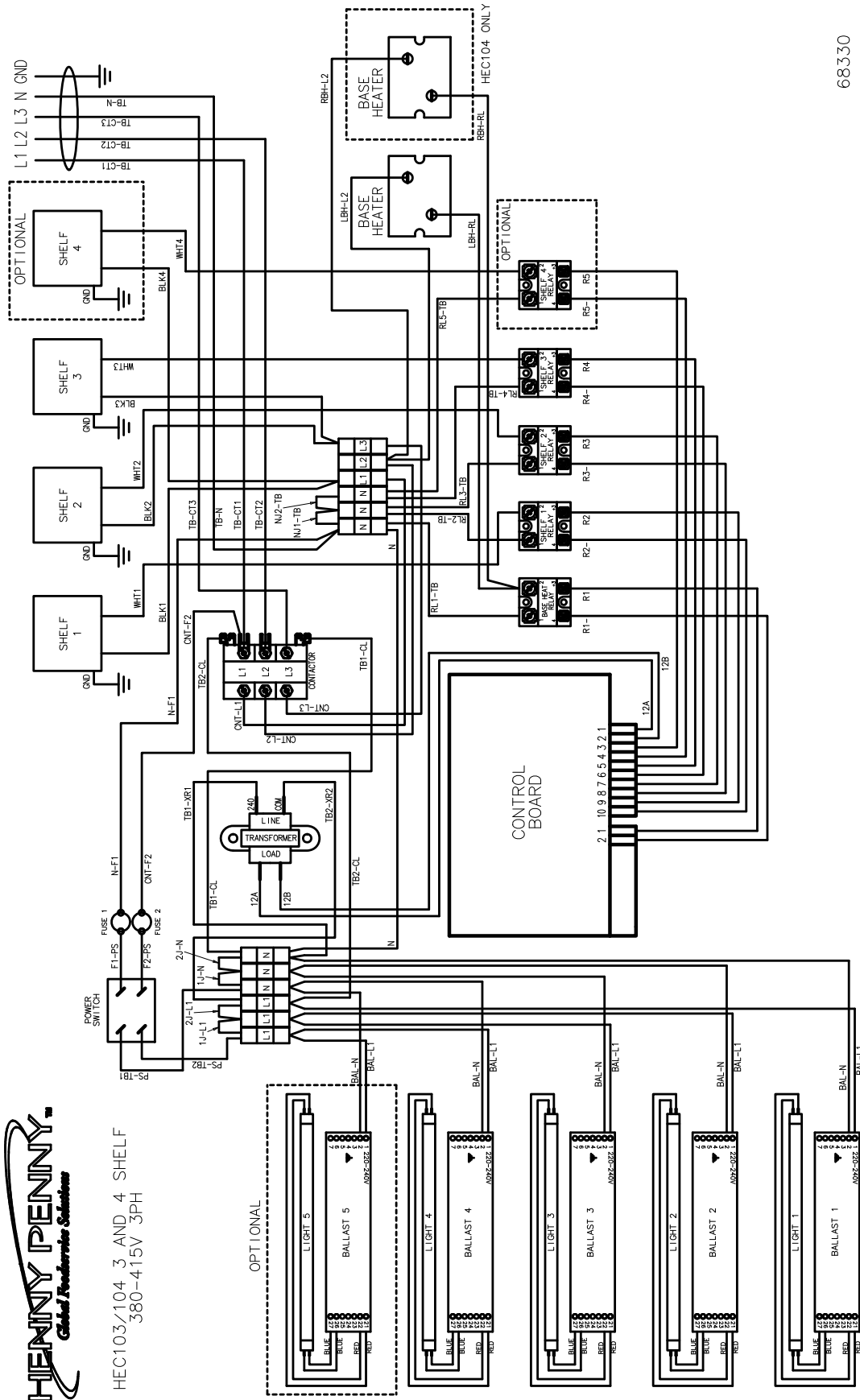

68330



HEC103/104, 3 AND 4 SHELF  
380-415V 3PH

SN: HC0708012 & ABOVE



HEC-123/124  
2-SHELF 1PH  
208/240V; 220-240V

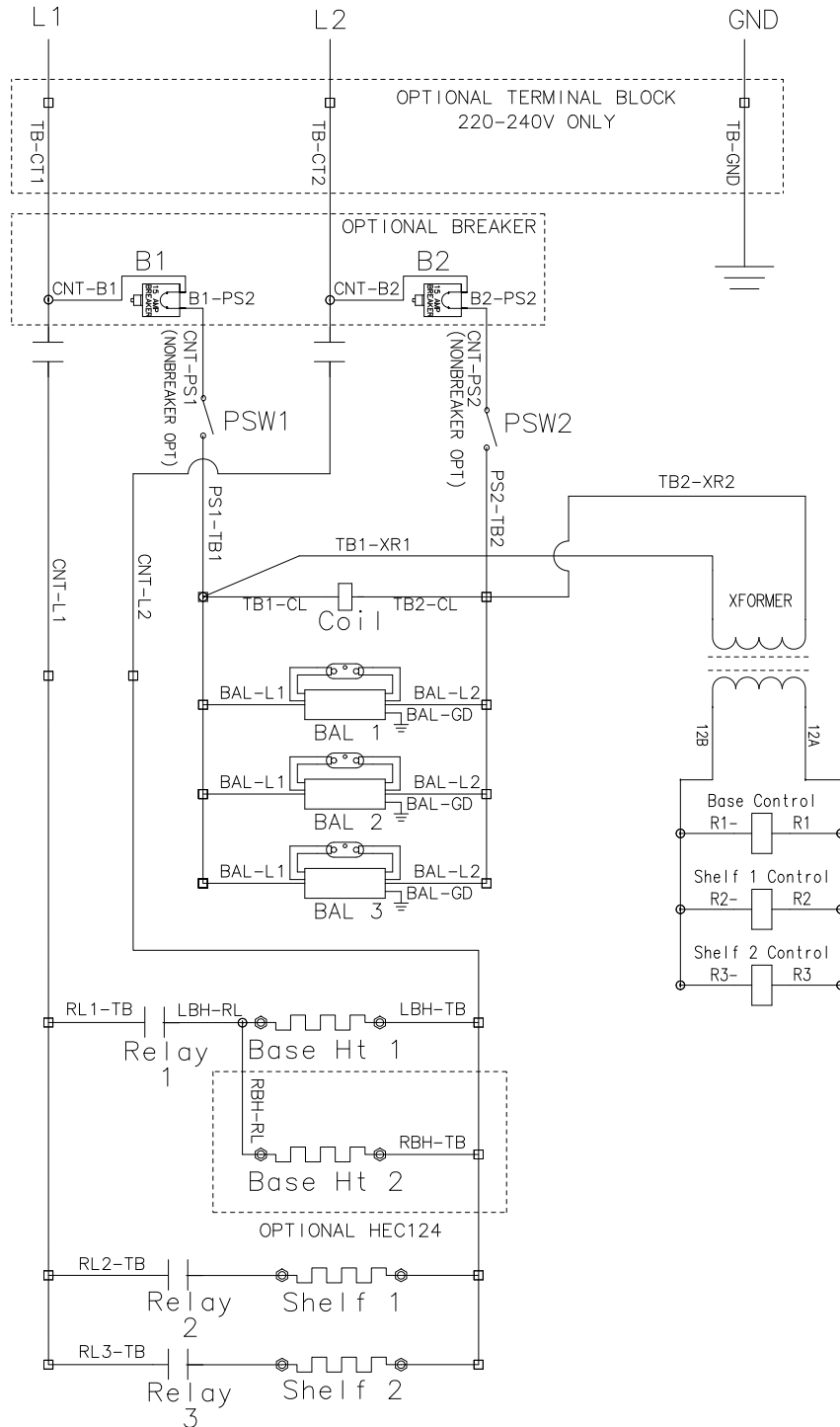

68628





HEC123 2 SHELF  
OR  
HEC124 2 SHELF  
208, 240, 220-240V 1PH

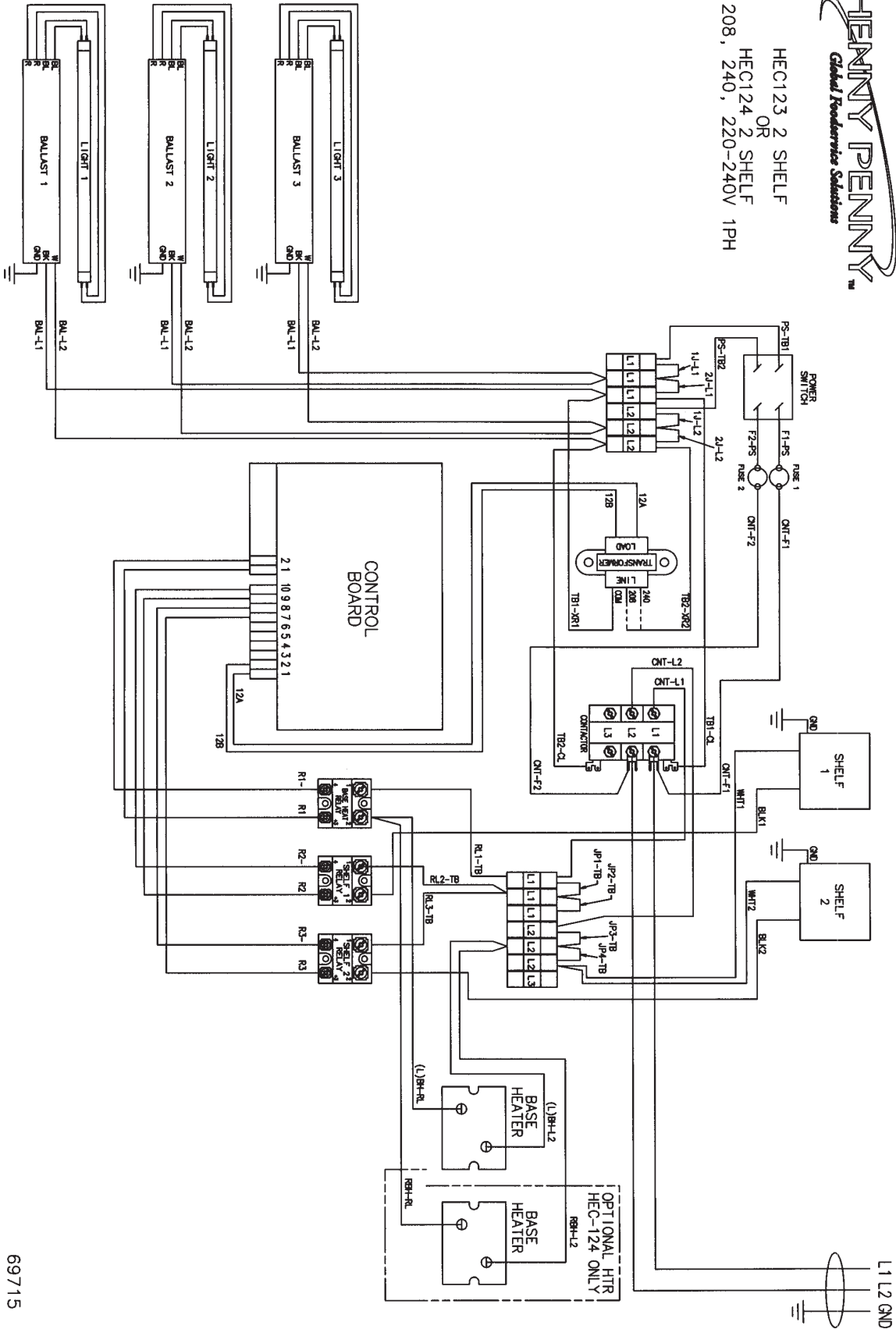

69715

**SN: HC0603019 & BELOW**

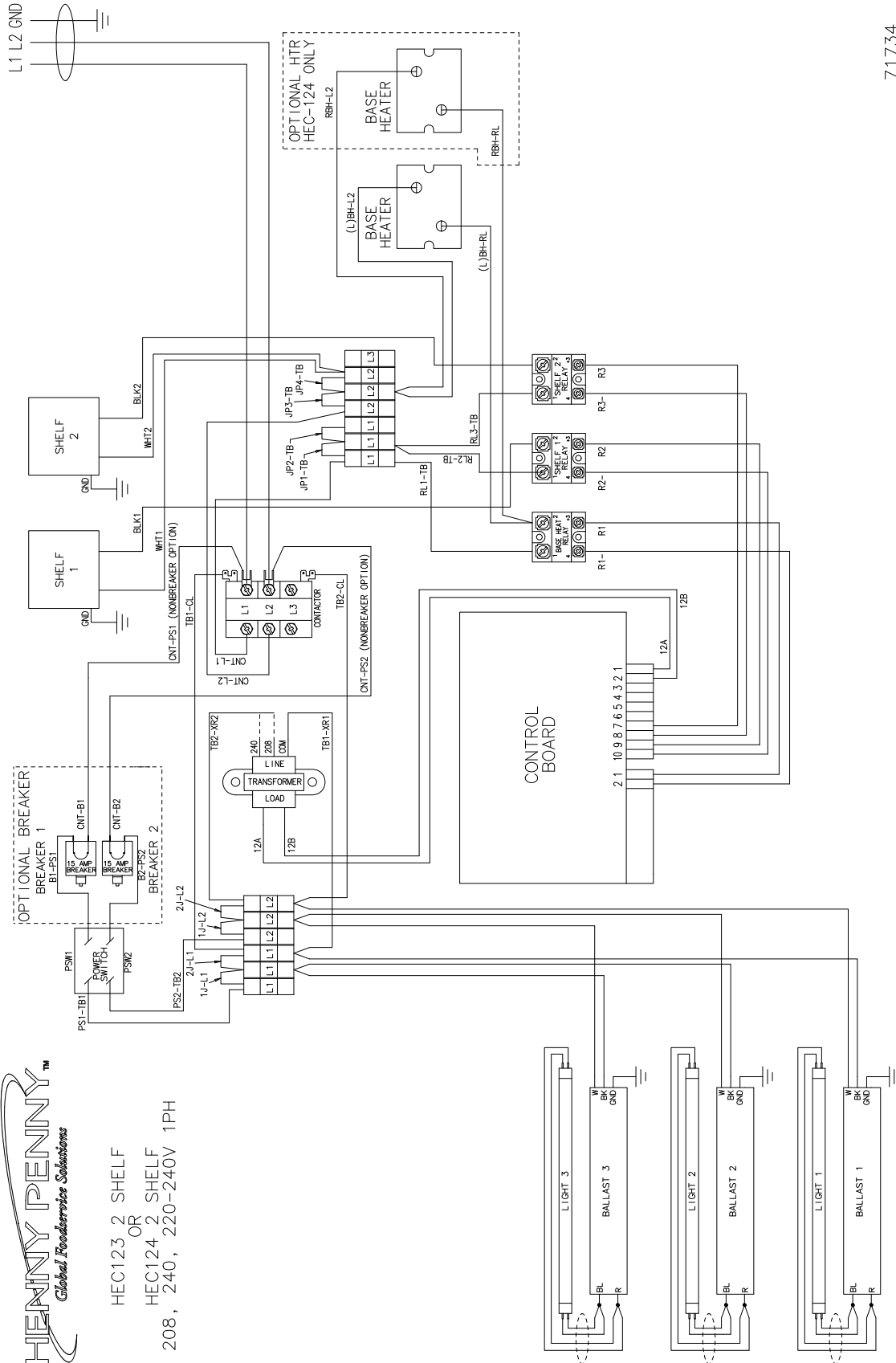

71734

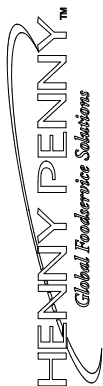

HEC123 2 SHELF  
OR  
HEC124 2 SHELF  
208, 240, 220-240V 1PH

**SN: HC0603020 & ABOVE**



HEC-12X 2-SHELF  
230V/1PH

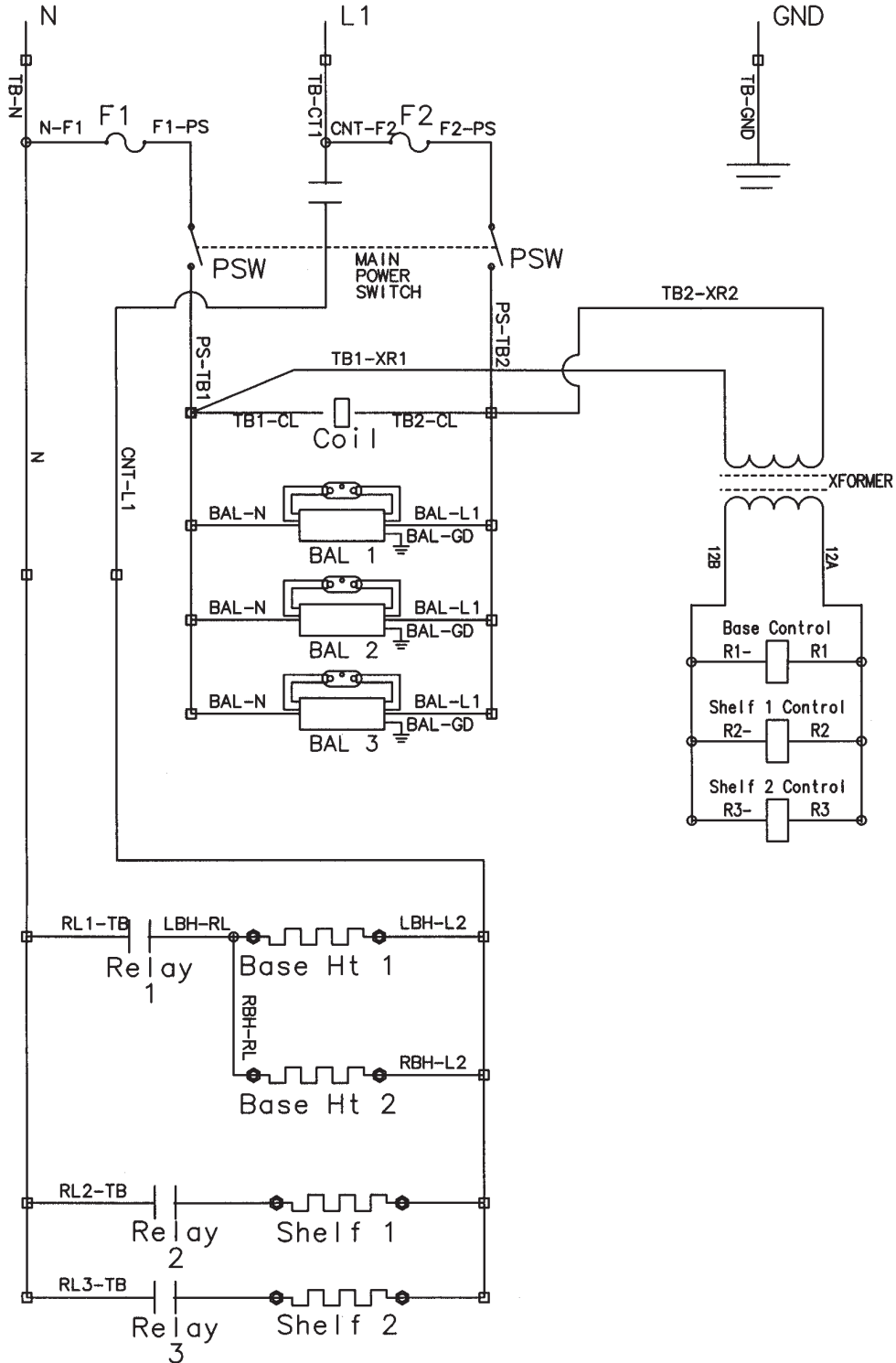

69566



HEC123 2 SHELF  
OR  
HEC124 2 SHELF  
230V 1PH

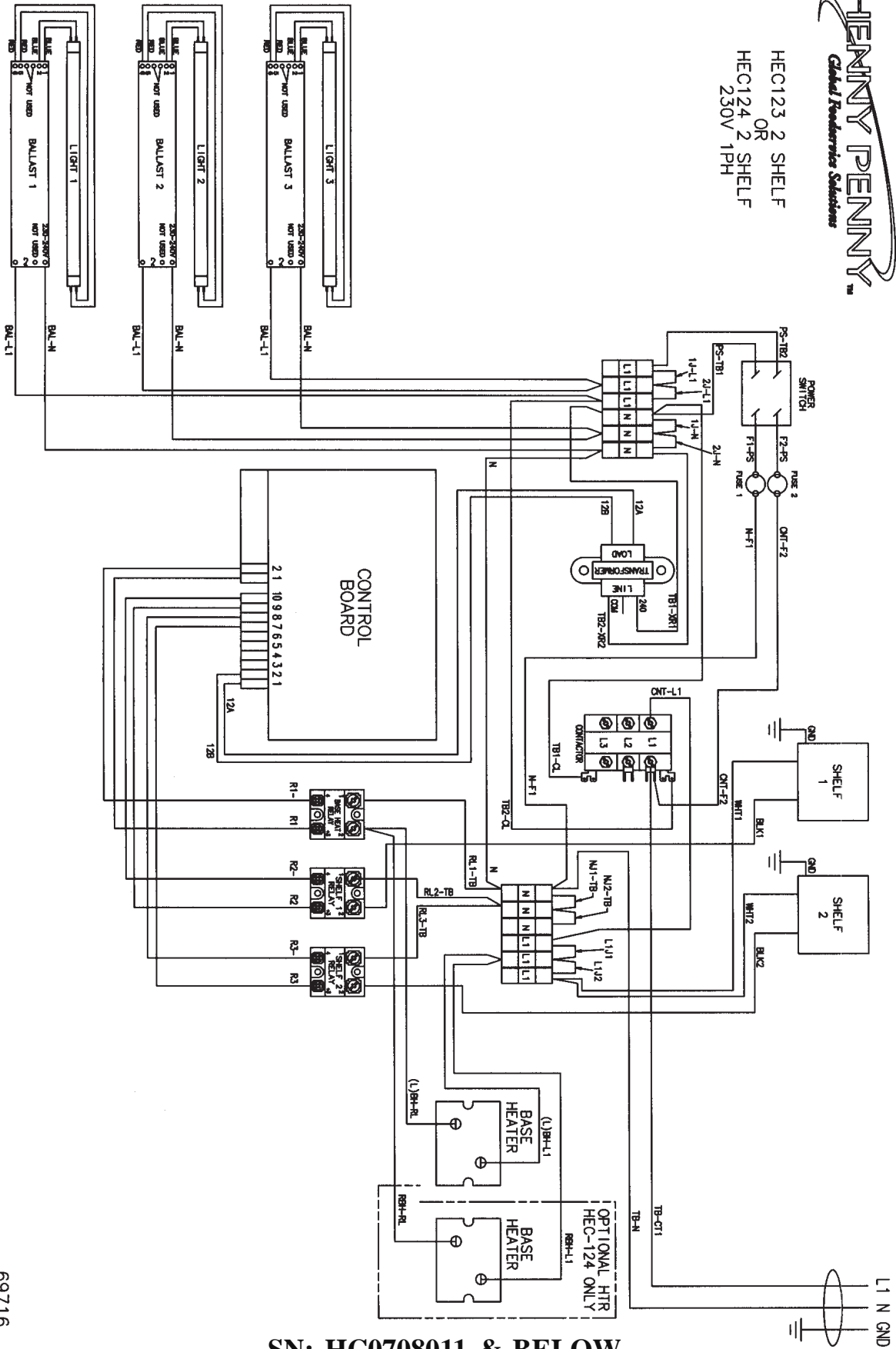

SN: HC0708011 & BELOW

69716

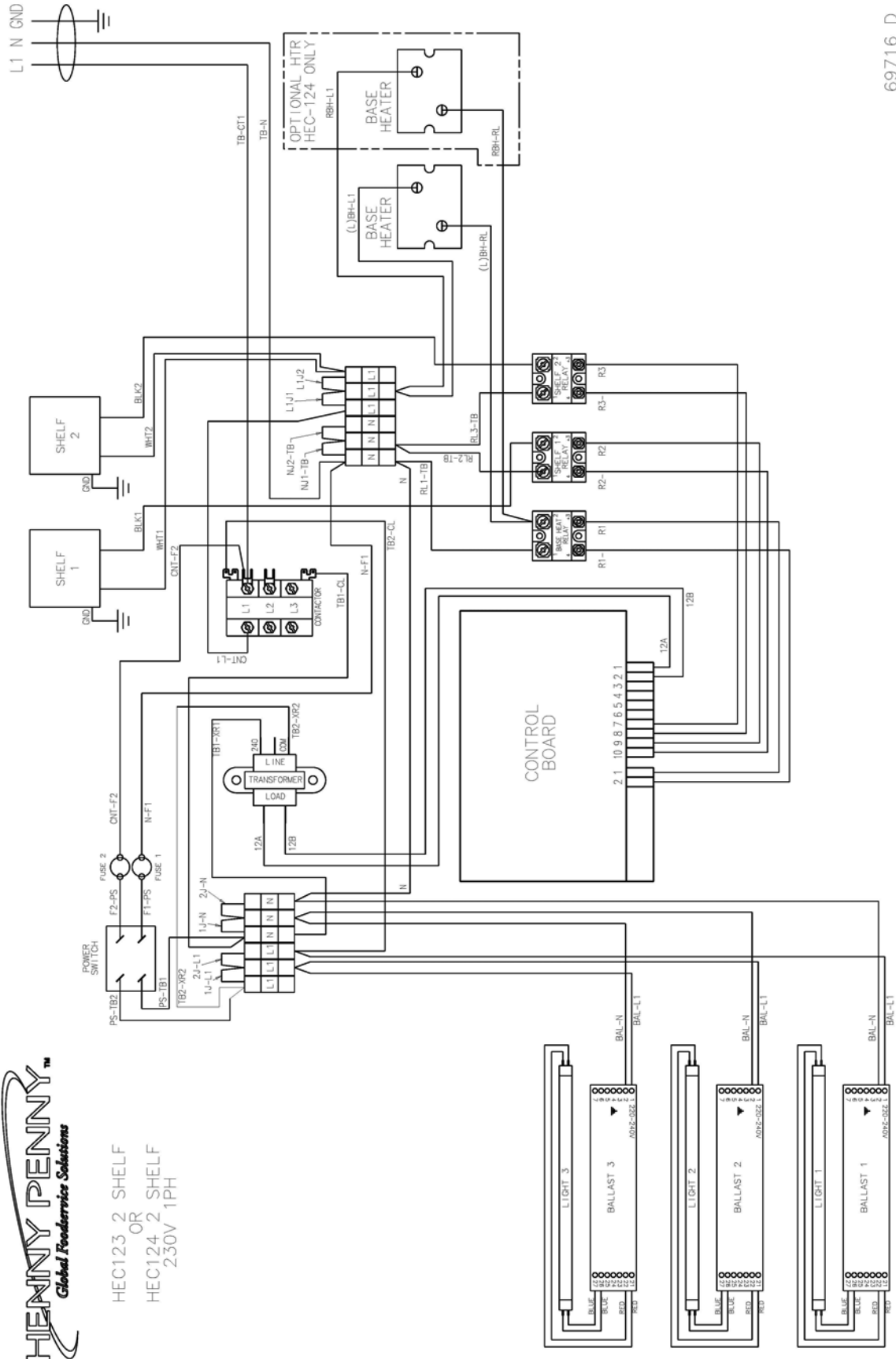

69716\_D



HEC123 2 SHELF  
OR  
HEC124 2 SHELF  
230V 1PH

SN: HC0708012 & ABOVE



HEC-12X 2-SHELF  
380-415V/3PH

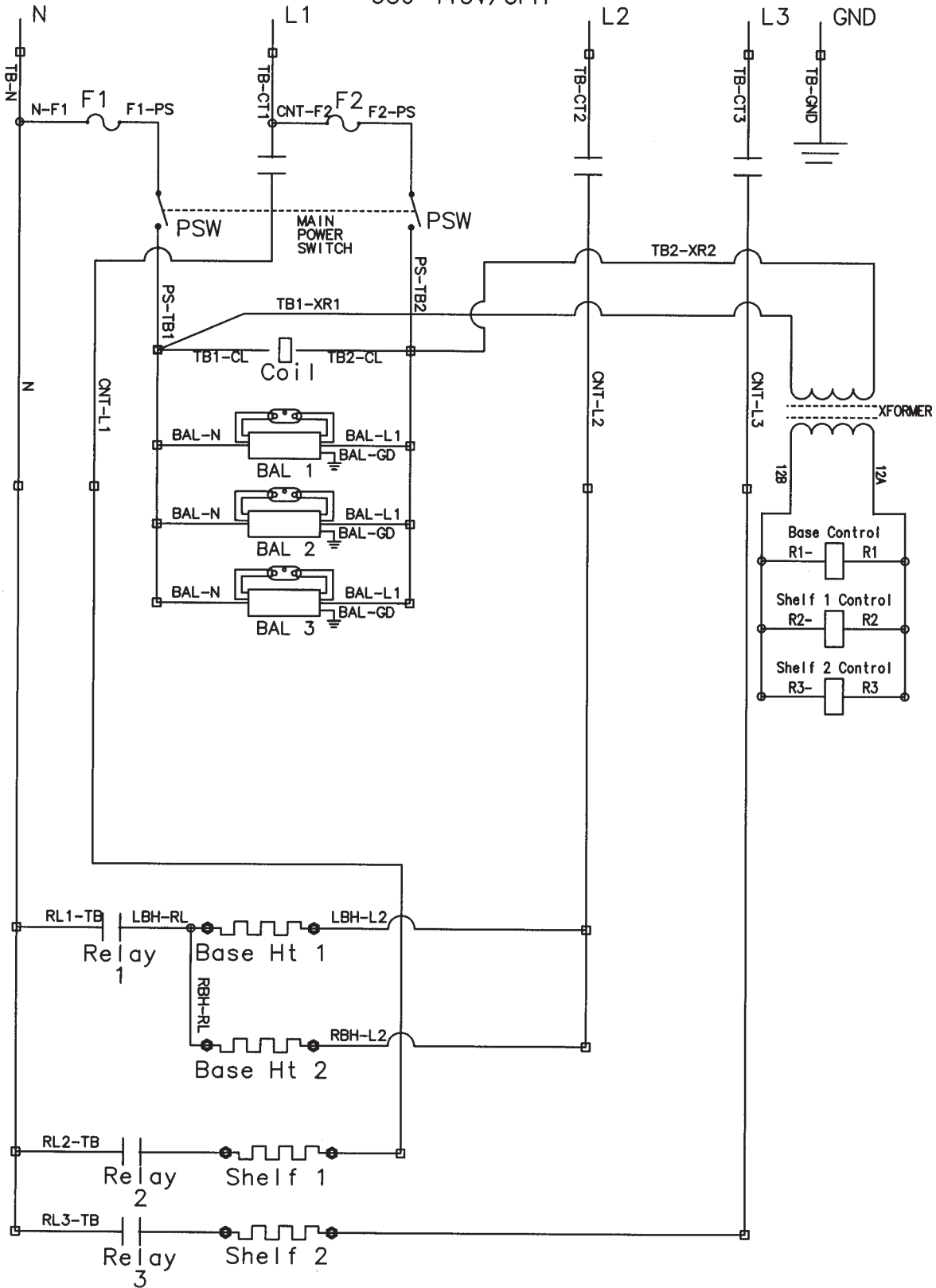

69196

## SECTION 3. PARTS INFORMATION

### **3-1. INTRODUCTION**

This section identifies and lists the replaceable parts of the Henny Penny merchandiser.

### **3-2. GENUINE PARTS**

Use only genuine Henny Penny parts in your cabinet. Using a part of lesser quality or substitute design may result in cabinet damage or personal injury.

### **3-3. HOW TO ORDER**

Once the part you want to order has been found in the Parts List, write down the following information:

1. From the Parts List  
(Sample)

Item Number 3  
Part Number 40645  
Description Relay

2. From the data plate  
(Sample)

Product Number HEC104.0  
Serial Number AY001JJ  
Voltage 102/208V

### **3-4. PRICES**

Your independent Henny Penny distributor has a price parts list and will be glad to inform you of the cost of your parts order.

### **3-5. DELIVERY**

Commonly replaced items are stocked by your independent Henny Penny distributor and will be sent out when your order is received. Other parts will be ordered by the distributor from Henny Penny Corporation. Normally, these will be sent to your distributor within three working days.

### **3-6. WARRANTY**

All replacement parts (except lamps and fuses) are covered under warranty for 90 days against manufacturing defects and workmanship. If damage occurs during shipping, notify the carrier at once so that a claim may be properly filed. Refer to warranty on the front of this section for other rights and limitations.

### **3-7. RECOMMENDED SPARE PARTS FOR DISTRIBUTORS**

Recommended replacement parts, stocked by your distributor, are indicated with √ in the parts lists. Please use care when ordering recommended parts, because all voltages and variations are marked. Distributors should order parts based upon common voltages and equipment sold in their territory.

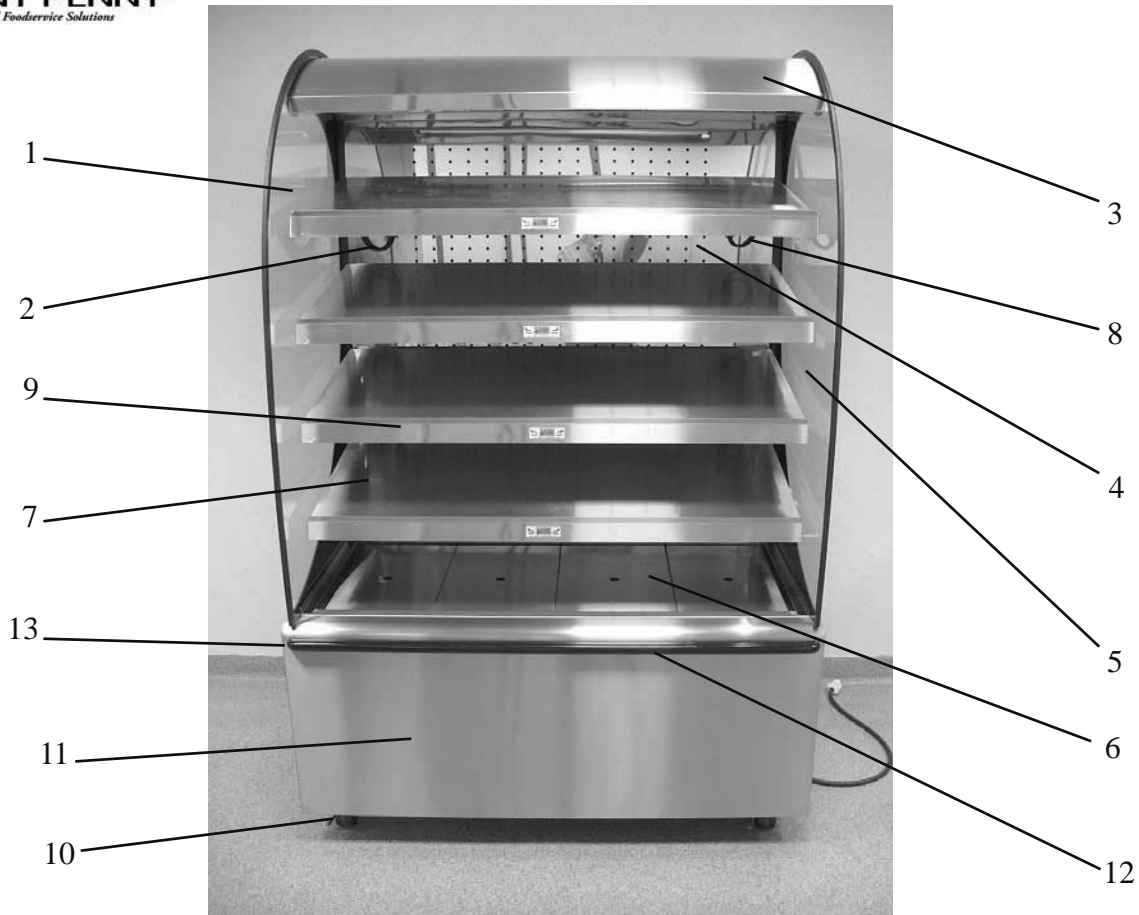

Item No.	Part No.	Description	Quantity			
			103	104	123	124
1	65645-001	Glass - Clear - LH Side - 10X	1	1	-	-
1	68158-001	Glass - Clear - LH Side - 12X	-	-	1	1
2	69230	Assy - Molded Cord Lamp Plug - 103/123	3 or 4	-	2	-
2	67893	Assy - Molded Cord Lamp Plug - 104/124	-	3 or 4	-	2
2	65995	Receptacle - Molded Harness Lamp - 103/123/104/124	3 or 4	3 or 4	2	2
3	65495	Cap- HEC-103/123 - Top	1	-	1	-
3	65497	Cap- HEC-104/124 - Top	-	1	-	1
4	66344	Panel - HEC-103 - Four Shelf Removable	1	-	-	-
4	66019	Panel - HEC-104 - Four Shelf Removable	-	1	-	-
4	66361	Panel - HEC-103 - Three Shelf Removable	1	-	-	-
4	66021	Panel - HEC-104 - Three Shelf Removable	-	1	-	-
4	69639	Panel - HEC-123 - Two Shelf Removable	-	-	1	-
4	68549	Panel - HEC-124 - Two Shelf Removable	-	-	-	1
5	65645-002	Glass - Clear - RH Side - 10X	1	1	-	-
5	68158-002	Glass - Clear - RH Side - 12X	-	-	1	1
6	65614	Panel - Bottom Insert - HEC-10X	3	4	3	4
7		Assy - Shelf - <b>See chart on Next 2 Pages</b>	3 or 4	3 or 4	2	2
8	66500	Assy - Cord Heater Plug	3 or 4	3 or 4	2	2
8	65992	Receptacle - Molded Harness Heat - 103/123/104/124	3 or 4	3 or 4	2	2
9	66274	Stud Assy - HEC-103 - Product Stop	3 or 4	-	2	-
9	66249	Stud Assy - HEC-104 - Product Stop	-	3 or 4	-	2
10	81699	Caster - 3" - Swivel w/Brake	2	2	2	2
11		Assy - Front Panel - <b>See Chart on Next Page</b>	1	1	1	1
12	66011-001	Bumper - Snap-On - HEC-103/123	1	-	1	-
12	66011-002	Bumper - Snap-On - HEC-104/124	-	1	-	1
13	54649	Snap-On End Cap (specify color)	2	2	2	2
14*	MS01-384	Strike - Latch -Male	10	12	10	12
15*	41356	Leg Assembly (Optional)	4	4	4	4
16*	81700	Caster - 3" - Swivel	2	2	2	2

\*not shown



Item	Part No.	Description	Language
11	67697-001	ASSY-FRONT REMOVABLE PANEL - HEC-104/124	ENGLISH
11	67697-002	ASSY-FRONT REMOVABLE PANEL - HEC-104/124	GERMAN
11	67697-003	ASSY-FRONT REMOVABLE PANEL - HEC-104/124	FRENCH
11	67697-004	ASSY-FRONT REMOVABLE PANEL - HEC-104/124	NORWEGIAN
11	67697-005	ASSY-FRONT REMOVABLE PANEL - HEC-104/124	SPANISH
11	67697-006	ASSY-FRONT REMOVABLE PANEL - HEC-104/124	DANISH
11	67697-007	ASSY-FRONT REMOVABLE PANEL - HEC-104/124	DUTCH
11	67697-008	ASSY-FRONT REMOVABLE PANEL - HEC-104/124	SWEDISH
11	69780-003	ASSY-FRONT REMOVABLE PANEL - HEC-104(specify color)	ENGLISH
11	67697-009	ASSY-FRONT REMOVABLE PANEL - HEC-103/123	ENGLISH
11	67697-010	ASSY-FRONT REMOVABLE PANEL - HEC-103/123	GERMAN
11	67697-011	ASSY-FRONT REMOVABLE PANEL - HEC-103/123	FRENCH
11	67697-012	ASSY-FRONT REMOVABLE PANEL - HEC-103/123	NORWEGIAN
11	67697-013	ASSY-FRONT REMOVABLE PANEL - HEC-103/123	SPANISH
11	67697-014	ASSY-FRONT REMOVABLE PANEL - HEC-103/123	DANISH
11	67697-015	ASSY-FRONT REMOVABLE PANEL - HEC-103/123	DUTCH
11	67697-016	ASSY-FRONT REMOVABLE PANEL - HEC-103/123	SWEDISH
11	69795-003	ASSY-FRONT REMOVABLE PANEL - HEC-103(specify color)	ENGLISH

Item	Part No.	Description	Language
7	67693-001	ASSY - SHELF - BLACK W/LABEL HOLDER - 208V - HEC104/124	ENGLISH
7	67693-002	ASSY - SHELF - BLACK W/LABEL HOLDER - 208V - HEC104/124	FRENCH
7	67693-003	ASSY - SHELF - BLACK W/LABEL HOLDER - 208V - HEC104/124	DANISH
7	67693-004	ASSY - SHELF - BLACK W/LABEL HOLDER - 208V - HEC104/124	SPANISH
7	67693-005	ASSY - SHELF - BLACK W/LABEL HOLDER - 208V - HEC104/124	GERMAN
7	67693-006	ASSY - SHELF - BLACK W/LABEL HOLDER - 208V - HEC104/124	DUTCH
7	67693-007	ASSY - SHELF - BLACK W/LABEL HOLDER - 208V - HEC104/124	SWEDISH
7	67693-008	ASSY - SHELF - BLACK W/LABEL HOLDER - 208V - HEC104/124	NORWEGIAN
7	67693-009	ASSY - SHELF - BLACK W/LABEL HOLDER - 240V - HEC104/124	ENGLISH
7	67693-010	ASSY - SHELF - BLACK W/LABEL HOLDER - 240V - HEC104/124	FRENCH
7	67693-011	ASSY - SHELF - BLACK W/LABEL HOLDER - 240V - HEC104/124	DANISH
7	67693-012	ASSY - SHELF - BLACK W/LABEL HOLDER - 240V - HEC104/124	SPANISH
7	67693-013	ASSY - SHELF - BLACK W/LABEL HOLDER - 240V - HEC104/124	GERMAN
7	67693-014	ASSY - SHELF - BLACK W/LABEL HOLDER - 240V - HEC104/124	DUTCH
7	67693-015	ASSY - SHELF - BLACK W/LABEL HOLDER - 240V - HEC104/124	SWEDISH
7	67693-016	ASSY - SHELF - BLACK W/LABEL HOLDER - 240V - HEC104/124	NORWEGIAN

Item	Part No.	Description	Language
7	67693-017	ASSY - SHELF - BLACK W/LABEL HOLDER - 208V - HEC103/123	ENGLISH
7	67693-018	ASSY - SHELF - BLACK W/LABEL HOLDER - 208V - HEC103/123	FRENCH
7	67693-019	ASSY - SHELF - BLACK W/LABEL HOLDER - 208V - HEC103/123	DANISH
7	67693-020	ASSY - SHELF - BLACK W/LABEL HOLDER - 208V - HEC103/123	SPANISH
7	67693-021	ASSY - SHELF - BLACK W/LABEL HOLDER - 208V - HEC103/123	GERMAN
7	67693-022	ASSY - SHELF - BLACK W/LABEL HOLDER - 208V - HEC103/123	DUTCH
7	67693-023	ASSY - SHELF - BLACK W/LABEL HOLDER - 208V - HEC103/123	SWEDISH
7	67693-024	ASSY - SHELF - BLACK W/LABEL HOLDER - 208V - HEC103/123	NORWEGIAN
7	67693-025	ASSY - SHELF - BLACK W/LABEL HOLDER - 240V - HEC103/123	ENGLISH
7	67693-026	ASSY - SHELF - BLACK W/LABEL HOLDER - 240V - HEC103/123	FRENCH
7	67693-027	ASSY - SHELF - BLACK W/LABEL HOLDER - 240V - HEC103/123	DANISH
7	67693-028	ASSY - SHELF - BLACK W/LABEL HOLDER - 240V - HEC103/123	SPANISH
7	67693-029	ASSY - SHELF - BLACK W/LABEL HOLDER - 240V - HEC103/123	GERMAN
7	67693-030	ASSY - SHELF - BLACK W/LABEL HOLDER - 240V - HEC103/123	DUTCH
7	67693-031	ASSY - SHELF - BLACK W/LABEL HOLDER - 240V - HEC103/123	SWEDISH
7	67693-032	ASSY - SHELF - BLACK W/LABEL HOLDER - 240V - HEC103/123	NORWEGIAN
7	67732-001	ASSY-SHELF - SS W/O LABEL HOLDER - 208V - HEC104/124	ENGLISH
7	67732-002	ASSY-SHELF - SS W/O LABEL HOLDER - 208V - HEC104/124	FRENCH
7	67732-003	ASSY-SHELF - SS W/O LABEL HOLDER - 208V - HEC104/124	DANISH
7	67732-004	ASSY-SHELF - SS W/O LABEL HOLDER - 208V - HEC104/124	SPANISH
7	67732-005	ASSY-SHELF - SS W/O LABEL HOLDER - 208V - HEC104/124	GERMAN
7	67732-006	ASSY-SHELF - SS W/O LABEL HOLDER - 208V - HEC104/124	DUTCH
7	67732-007	ASSY-SHELF - SS W/O LABEL HOLDER - 208V - HEC104/124	SWEDISH
7	67732-008	ASSY-SHELF - SS W/O LABEL HOLDER - 208V - HEC104/124	NORWEGIAN
7	67732-009	ASSY-SHELF - SS W/O LABEL HOLDER - 240V - HEC104/124	ENGLISH
7	67732-010	ASSY-SHELF - SS W/O LABEL HOLDER - 240V - HEC104/124	FRENCH
7	67732-011	ASSY-SHELF - SS W/O LABEL HOLDER - 240V - HEC104/124	DANISH
7	67732-012	ASSY-SHELF - SS W/O LABEL HOLDER - 240V - HEC104/124	SPANISH
7	67732-013	ASSY-SHELF - SS W/O LABEL HOLDER - 240V - HEC104/124	GERMAN
7	67732-014	ASSY-SHELF - SS W/O LABEL HOLDER - 240V - HEC104/124	DUTCH
7	67732-015	ASSY-SHELF - SS W/O LABEL HOLDER - 240V - HEC104/124	SWEDISH
7	67732-016	ASSY-SHELF - SS W/O LABEL HOLDER - 240V - HEC104/124	NORWEGIAN
7	67732-017	ASSY-SHELF - SS W/O LABEL HOLDER - 208V - HEC103/123	ENGLISH
7	67732-018	ASSY-SHELF - SS W/O LABEL HOLDER - 208V - HEC103/123	FRENCH
7	67732-019	ASSY-SHELF - SS W/O LABEL HOLDER - 208V - HEC103/123	DANISH
7	67732-020	ASSY-SHELF - SS W/O LABEL HOLDER - 208V - HEC103/123	SPANISH
7	67732-021	ASSY-SHELF - SS W/O LABEL HOLDER - 208V - HEC103/123	GERMAN
7	67732-022	ASSY-SHELF - SS W/O LABEL HOLDER - 208V - HEC103/123	DUTCH
7	67732-023	ASSY-SHELF - SS W/O LABEL HOLDER - 208V - HEC103/123	SWEDISH
7	67732-024	ASSY-SHELF - SS W/O LABEL HOLDER - 208V - HEC103/123	NORWEGIAN
7	67732-025	ASSY-SHELF - SS W/O LABEL HOLDER - 240V - HEC103/123	ENGLISH
7	67732-026	ASSY-SHELF - SS W/O LABEL HOLDER - 240V - HEC103/123	FRENCH
7	67732-027	ASSY-SHELF - SS W/O LABEL HOLDER - 240V - HEC103/123	DANISH
7	67732-028	ASSY-SHELF - SS W/O LABEL HOLDER - 240V - HEC103/123	SPANISH
7	67732-029	ASSY-SHELF - SS W/O LABEL HOLDER - 240V - HEC103/123	GERMAN
7	67732-030	ASSY-SHELF - SS W/O LABEL HOLDER - 240V - HEC103/123	DUTCH
7	67732-031	ASSY-SHELF - SS W/O LABEL HOLDER - 240V - HEC103/123	SWEDISH
7	67732-032	ASSY-SHELF - SS W/O LABEL HOLDER - 240V - HEC103/123	NORWEGIAN

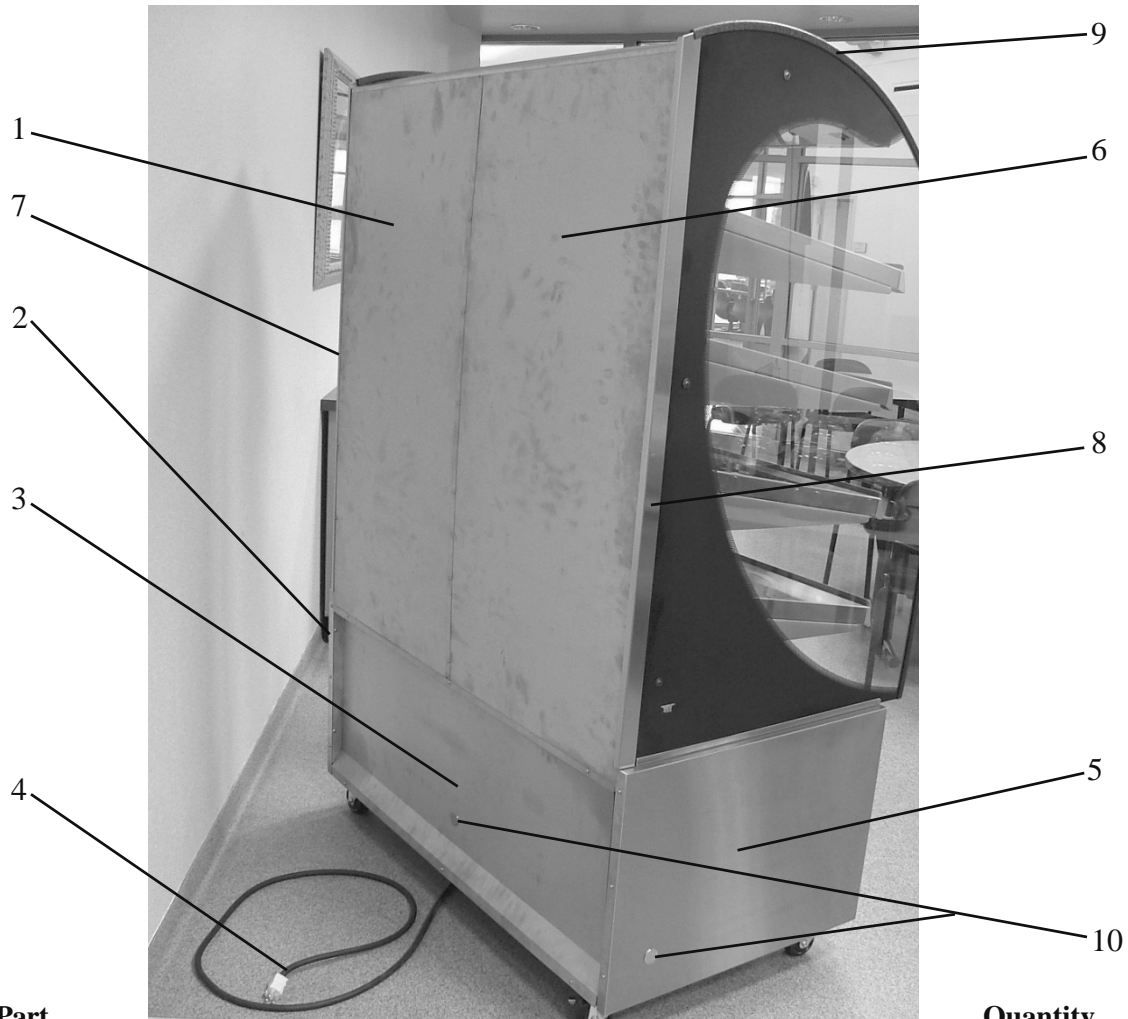

Item No.	Part No.	Description	Quantity			
			103	104	123	124
1	66014	Panel - LH Rear - HEC-10X	1	1	-	-
1	68556	Panel - LH Rear - HEC-12X	-	-	1	1
2	65530	Panel - RH Side	1	1	1	1
3	66432	Panel - Lower Rear - HEC-103/123	1	-	1	-
3	65659	Panel - Lower Rear - HEC-104/124	-	1	-	1
4	66086	Assy - 1PH-20A-12Ga - Power Cord	1	1	1	1
4	66128	Assy - 1PH-30A-12Ga - Power Cord	-	1	-	-
4	66140	Assy - 3PH-15A-12Ga - Power Cord	1	1	-	-
5	66030	Panel - LH Side	1	1	1	1
6	66300	Panel -HEC-103 - RH Rear	1	-	-	-
6	66015	Panel -HEC-104 - RH Rear	-	1	-	-
6	69641	Panel -HEC-123 - RH Rear	-	-	1	-
6	68557	Panel -HEC-124 - RH Rear	-	-	-	1
7	66022	Stud Assy. - LH-HEC-10X Trim	1	1	-	-
7	68554	Stud Assy. - LH-HEC-12X Trim	-	-	1	1
8	66025	Stud Assy. - RH-HEC-10X Trim	1	1	-	-
8	68555	Stud Assy. - RH-HEC-12X Trim	-	-	1	1
9	MS01-509	Trimlock 1/4 Black Edge Guard	12ft	12ft	9.25ft	9.25ft
10	PL01-033	1-1/8 Plug Button - NI PL TD	3	3	3	3
11*	69208	Insulation - Rear Panel - 103/123	3	4	-	-
11*	69744	Insulation - Rear Panel - 104/124	-	-	3	4

\*not shown

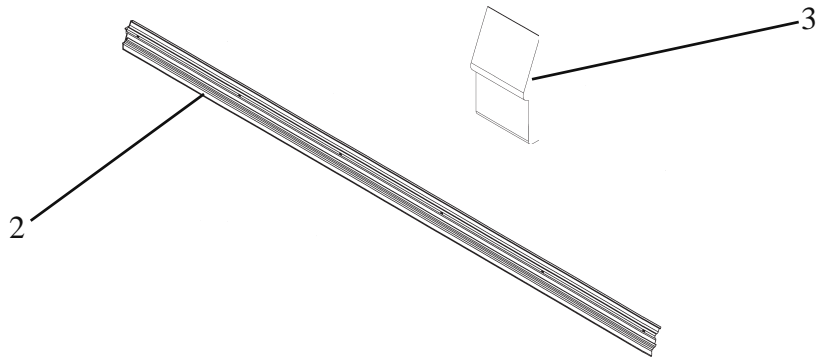
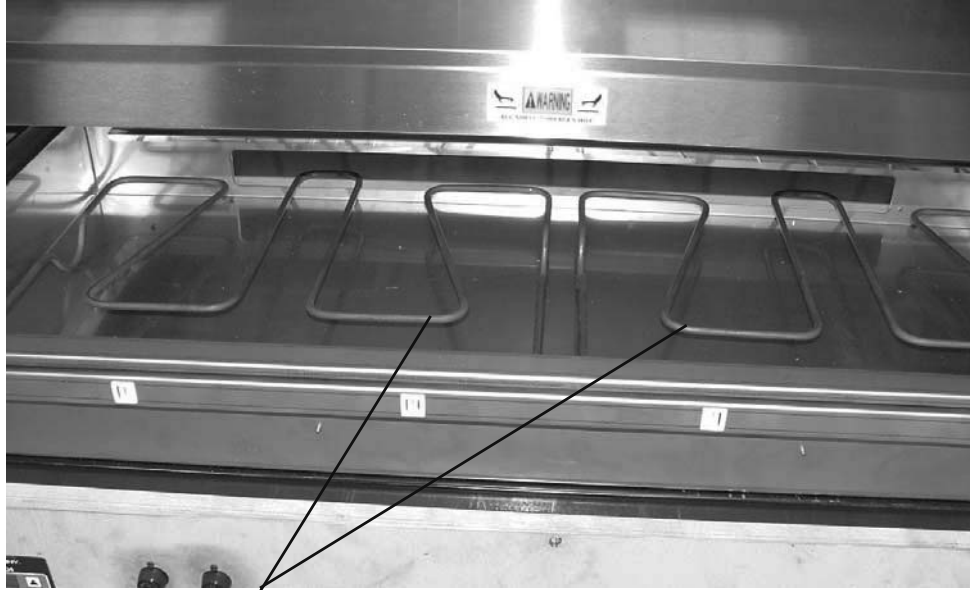

Item No.	Part No.	Description	Quantity			
			103	104	123	124
√ 1	66659-001	Heater - HEC-103/123 - 1100W-208V - Well	1	-	1	-
√ 1	66659-002	Heater - HEC-103/123 - 1100W-240V - Well	1	-	1	-
√ 1	65566-001	Heater - HEC-104/124 - 825W-208V - Well	-	2	-	2
√ 1	65566-002	Heater - HEC-104/124 - 825W-240V - Well	-	2	-	2
	2 65951-001	Holder - Price Label - HEC-104 (Optional)	-	3 or 4	-	2
	2 65951-002	Holder - Price Label - HEC-103 (Optional)	3 or 4	-	2	-
	3 66121	Gasket - Price Label (Optional)	6 or 8	6 or 8	4	4

√ recommended parts

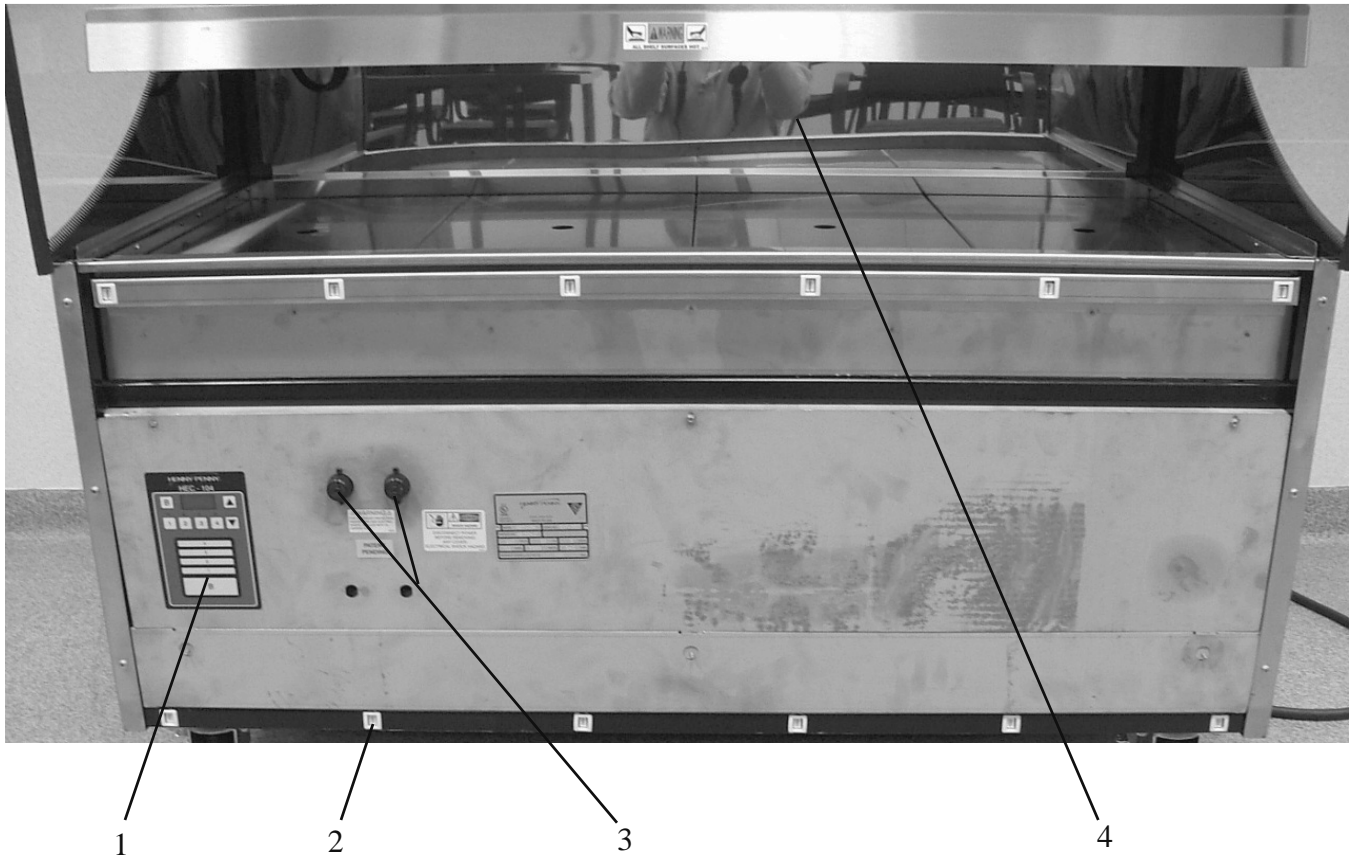

Item No.	Part No.	Description	Quantity				
			103	104	123	124	
	1	65785	Decal - HEC-10X - 4 Shelf	1	1	-	-
	1	66038	Decal - HEC-10X - 3 Shelf	1	1	-	-
	1	68579	Decal - HEC-12X - 2 Shelf	-	-	1	1
	2	MS01-383	Latch (Plastic) - Female - Front Panel	10	12	10	12
√	3	EF02-006	Fuse Holder - 15 Amp (See SN Chart)	2	2	2	2
√	3	EF02-007	Fuse - 15 Amp (See SN Chart)	2	2	2	2
√	3	EF02-125	Breaker-Push Button Reset (See SN Chart)	2	2	2	2
√	3	EF02-104	Fuse Holder - 20 Amp - CE	2	2	2	2
√	3	EF02-105	Fuse - 15 Amp - CE	2	2	2	2
	4	66411	Panel - HEC-103 Lower - Removable	1	-	1	-
	4	66020	Panel - HEC-104 Lower - Removable	-	1	-	1

√ recommended parts

### Fuse, Fuse Holder and Breaker SN Chart

	PART #	
<b>MODELS</b>	EF02-006 & EF02-007	EF02-125
HEC103	HC0701010 & below	HC0701011 & above
HEC123	HC0701016 & below	HC0701017 & above



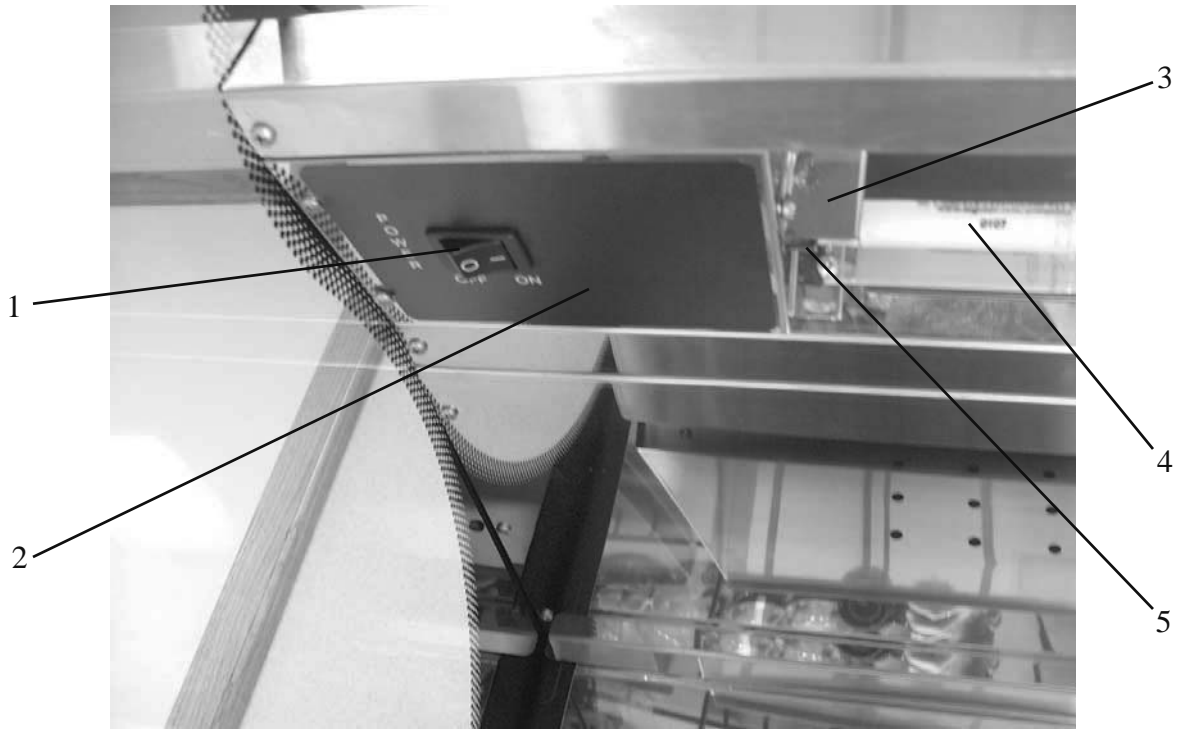

Item No.	Part No.	Description	Quantity			
			103	104	123	124
√ 1	72277	Power switch	2	2	2	2
2	66063	Decal - Power Switch	1	1	1	1
3	66106	Retainer - Ceiling Lamp	8 or 10	8 or 10	6	6
√ 4	BL01-026	Light - Fourescent - F14T5	4 or 5	-	3	-
√ 4	BL01-025	Light - Fourescent - F21T5	-	4 or 5	-	3
√ 5	70157	Assy - Lampholder - T5 Lamp - Bi Pin	8 or 10	8 or 10	6	6

√ recommended parts