

SECTION 3. PARTS INFORMATION

3-1. INTRODUCTION

This section identifies and lists the replaceable parts of the Henny Penny Model HHC-900 heated holding cabinet.

3-2. GENUINE PARTS

Use only genuine Henny Penny parts in your cabinet. Using a part of lesser quality or substitute design may result in cabinet damage or personal injury.

3-3. HOW TO FIND PARTS

To find items you want to order from the Parts List, proceed as follows:

1. Referring to the illustration in this section, find the part item number of the part needed.
2. Find the item number in the parts list, which shows the Henny Penny part number, a description of the part, any model or usage limitations, and the quantity of parts used.

3-4. HOW TO ORDER

Once the parts you want to order have been found in the Parts List, write down the following information:

Example:

Item number	<u>44</u>
Part number	<u>14635</u>
Description	<u>Power Switch</u>

From the data plate list the following information:

Example:

Product number	<u>HHC-900.0</u>
Serial number	<u>00179</u>
Voltage	<u>120</u>

3-4. HOW TO ORDER
(Continued)

The following table has been provided as a sample format for you to use in preparing your spare parts orders. By providing all the entries, your distributor will be able to ensure the correct parts will be sent to you. Also, by prepayment your order will be expedited.

FROM PARTS LIST			YOUR ORDER		
Item Number	Part Number	Description	Quantity Ordered	Price Each	Total
46	25183	Thermometer			
Product No. <u>HHC-900.0</u>			Serial No. <u>00179</u>		Voltage <u>120</u>

3-5. PRICES

Your distributor has a priced parts list and will be glad to inform you of the cost of your parts order.

3-6. DELIVERY

Commonly replaced items are stocked by your distributor and will be sent out when your order is received. Other parts will be ordered by your distributor from Henny Penny Corporation. Normally, these will be sent to your distributor within three working days.

3-7. WARRANTY

All replacement parts (except lamps and fuses) are warranted for 90 days against manufacturing defects and workmanship. If damage occurs during shipping, notify the sender and the carrier at once so that a claim may be properly filed. Refer to warranty in the front of this section for other rights and limitations.

3-8. RECOMMENDED SPARE PARTS FOR DISTRIBUTORS

Recommended replacement parts, stocked by your distributor, are indicated with √ in the parts lists. Please use care when ordering recommended parts, because all voltages and variations are marked. Distributors should order parts based upon common voltages and equipment sold in their territory.

UL & CE Approved - HHC-900/902/903/904/906/908

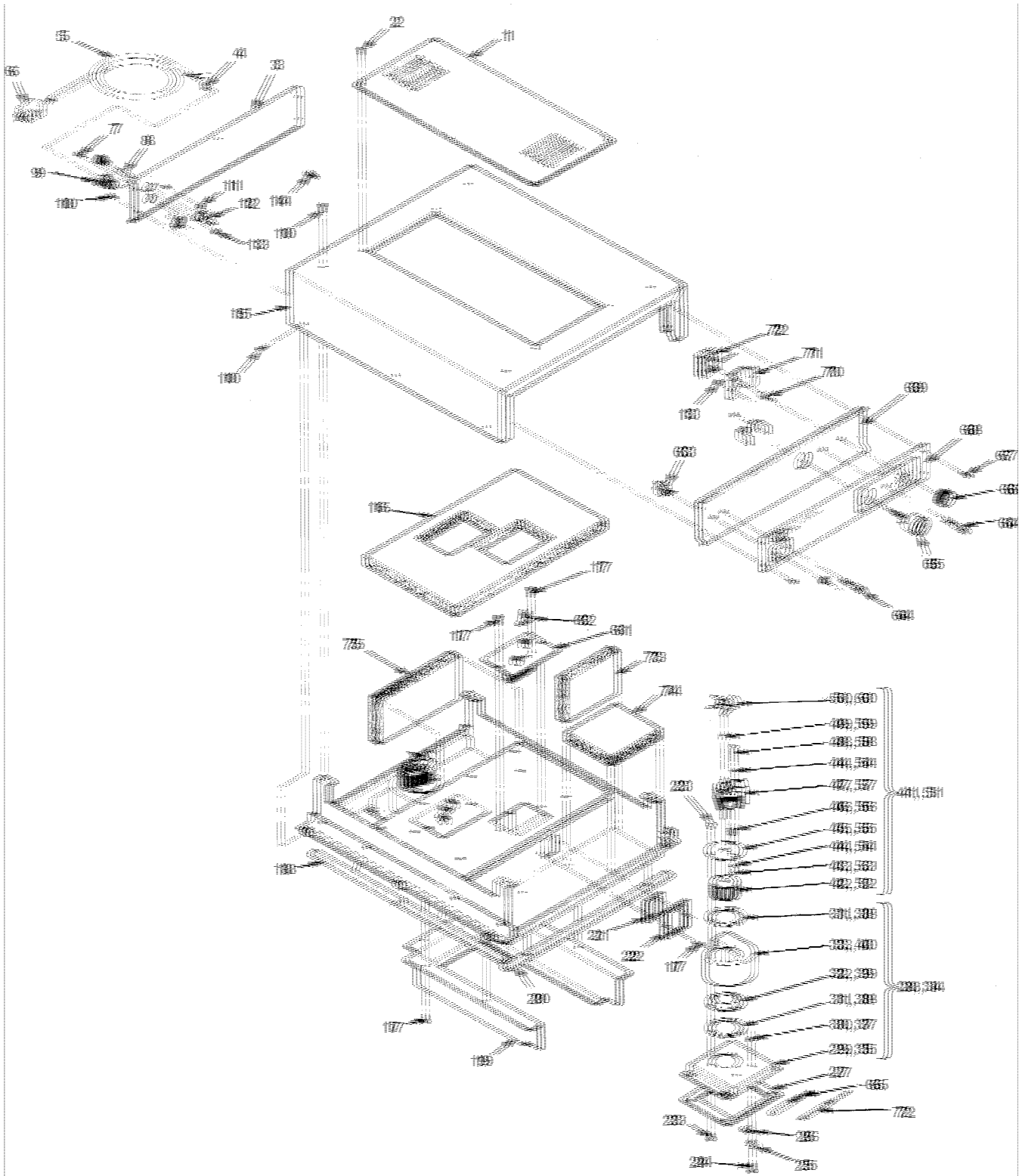

Figure 3-1. Control Module Assembly - UL & CE Approved

UL & CE Approved - HHC-900/902/903/904/906/908

<u>Figure No.</u> <u>& Item No.</u>	<u>Part No.</u>	<u>Description</u>	<u>Quantity</u>
3-1		Control Module Assembly - UL & CE Approved	
1	25704	Panel - Access	1
1	51209	Panel -Access - C E	1
2	SC01-053	Screw #8-32 x 1/2 PH RHD	4
3	48993	Panel - Rear (208/240V) S/A	1
3	71092	Panel - Rear (120V) S/A	1
3	25944	Panel Rear S/A: HC-903	1
3	28121	Panel - Rear HHC-906; HHC-908	1
3	49018	Panel - Rear - CE	1
4	EC04-002	Terminal Flag #10-10-12 Ga.....	1
5	MS01-212	Cable #12/3, 2,000W/120V	8 Ft.
5	MS01-175	Cable #14/3; 1500W/120V & 3000W/240V	8 Ft.
5	67390	Power Cord Assy. - Twist - 120V/20A.....	1
5	67472	Power Cord Assy. - 125V, 20 Amp	1
5	44857	Power Cord Assy. - 1.0MM - CE.....	1
5	71119	Power Cord Assy. - 1.5MM - HHC-906 - CE.....	1
5	71120	Power Cord Assy. - Canada - 120V/30A-RT Angle	1
5	68412	Power Cord Assy. - Canada - 208/240/20A	1
5	68413	Power Cord Assy. - 208/240/20A	1
5	71384	Power Cord Assy. - Harmonized - Int'l. - 240V	1
6	25765	Plug 125V, 20 Amp; Used on 2000W/120V	1
6	25764	Plug 125V, 15 Amp, Used on 1500W/120V	1
6	63943	Plug 250V, 20 Amp; Used on 3000W/240V	1
6	28543	Plug - Twist - 120V/20A.....	1
6	71717	Plug - 120V, 30 Amp - RT Angle - Canada.....	1
7	SC01-010	Screw #6-32 x 112 pH PHD	2
A 8	EF02-007	Fuse 15 Amp	1
9	EF02-124	Connector - Cable 3/4	1
10	SC02-023	Screw 48-B x 3/8 pH THD	15
11	NS02-001	Nut #10-32 Hex Keps	1
A 12	EF02-006	Fuse Holder.....	1
13	NS02 005	Nut #6-32 Hex Keps	2
14	EC01-010	Wire Nut 12-18 Ga.....	2
15	76396	Top - Enclosure	1
15	28153	Top HHC-906, HHC-908.....	1
16	26225	Insulation - Cover	1
17	SC02-041	Screw #8-18 x 7/16 PH IND XTRNL TORX	18
18	25620	Seal.....	2
19	25670	Cradle.....	1
20	25624	Seal.....	2
21	25619	Gasket - Blower Outlet	2
22	25618	Gasket Retainer.....	2
23	SC02-012	Screw #12-AB x 3/8 Ph PHD	2
24	SC01-055	Screw #1 0-32 x 3/4 Hex HD.....	2
25	EF02-031	Clamp 1/4 x 3/8".....	2
26	EF02-033	Clamp 7/16 x 3/8".....	2
27	25627	Gasket	2
28	25872	Blower Box Assembly (903 and all others).....	1 or 2
29	25616	Box, Blower	1

√ recommended parts

UL & CE Approved - HHC-900/902/903/904/906/908

<u>Item No.</u>	<u>Part No.</u>	<u>Description</u>	<u>Quantity</u>
	30	NS02-001 Nut	2
	31	25698 Gasket, Blower Plate.....	2
	32	25622 Flange, Inlet	1
	33	25623 Housing, Blower	1
	34	25941 Blower Box Assembly (903 only)	1
	35	25924 Rear Box, Blower	1
	36*	25942 Hose Coupling	1
	37	NS02-001 Nut	2
	38	25698 Gasket, Blower Plate.....	2
	39	25622 Flange, Inlet	1
	40	25623 Housing, Blower	1
	41	25753 Blower Motor Assembly (120V)	2
	42	25621 Wheel, Blower, Std.	2
	43	SC01-023 Screw	8
	44	LW02-010 Lockwasher	8
	45	37157 Plate, Blower.....	2
	46	81606 Spacer, Motor.....	8
A	47	25751 Motor (120V).....	2
	48	SC01-091 Screw	4
	49	25768 Spacer, Fan.....	2
A	50	25706 Fan, Cooling.....	2
	51	14249 Blower Motor Assembly (240V)	2
	52	52240 Wheel, Blower, Int'l.....	2
	53	SC01-023 Screw	8
	54	LW02-010 Lockwasher	8
	55	37157 Plate, Blower.....	2
	56	81606 Spacer, Motor.....	8
A	57	25752 Motor (240V).....	2
	58	SC01-091 Screw	8
	59	25768 Spacer, Fan.....	2
A	60	25706 Fan, Cooling.....	2
A	61	51279 Heater 120V/1000W	2
A	61	74870 Heater 100V/1000W	2
A	61	67627 Heater 240V/1500W	2
A	61	51278 Heater 120V/750W	2
A	62	18201 High Limit Thermostat	2
A	62	59272 High Limit Sensor (manual reset)-CE	2
A	63	14635 Power Switch (toggle)	1
A	63	72277 Black Rocker Switch - CDT	1
A	63	52224 Rocker Switch - CDT - CE	1
B	64	16624 Indicator Light - Red.....	2
B	64	54085 Indicator Light - CE - Green.....	2
B	65	14250 Thermometer.....	1
	66	25863 Knob - Thermostat	1
	67	SC02-030 Screw #8-B x 3/8 PH THD Black Oxide.....	4
	68	25717 Label Control Panel	1
	68	44024 Label Control Panel - KFC	1
	68	61445 Label Control Panel-Pollo Campero.....	1
	68	61523 Label Control Panel-Pollo Campero - HHC-903.....	1

√ recommended parts/* not shown

UL & CE Approved - HHC-900/902/903/904/906/908

<u>Item No.</u>	<u>Part No.</u>	<u>Description</u>	<u>Quantity</u>
68	25948	Label Control Panel; Std. HHC-900 - Vented	1
68	44023	Label Control Panel KFC- Vented.....	1
68	49119	Label Control Panel; HHC-906/908 (rocker-after Nov. 1, 2005).....	1
68	28188	Label Control Panel; HHC-906 (toggle-before Nov. 1, 2005)	1
68	28190	Label Control Panel; HHC-908 (toggle-before Nov. 1, 2005)	1
68	85250	Label Control Panel KFC - CDT Vented.....	1
68	45616	Label Control Panel-HHC-906 Auto Water-CE	1
68	49060	Label Control Panel - CE - Std. HHC-900	1
68	61470	Label Control Panel - HHC-903 - Wendy's.....	1
69	25786	Panel Control S/A HHC-900	1
69	69856	Panel Control S/A HHC-900 - SimpleHold.....	1
69	25947	Panel Control S/A HHC-903	1
69	28182	Panel Control S/A HHC-906/908 (rocker-after Nov. 1, 2005).....	1
69	14684	Panel Control S/A HHC-906/908 (replaces toggle-before Nov. 1, 2005)	1
69	49054	Panel Control S/A - CE - Std. HHC-900	1
71	25241	Bracket Thermostat Mount.....	1
70	25263	Extension Thermostat Shaft.....	1
A 72	14209	Thermostat w/clips	1
73	25734	Insulation 5 x 7 x 1	2
74	25733	Insulation 6 x 6 1/2 x 1	4
75	25735	Insulation 5 x 10 1/2 x 1	2
76*	25950	Control Cable; HHC-903.....	1
77*	27849	Actuator HHC-903	1
78*	51214	Vent Housing - CE.....	2
79*	04158	Wiring Kit (higher wattage)-E/M-Top Cord.....	1
79*	01460	Wiring Kit (higher wattage)-E/M-Rear Cord	1
79*	01461	Wiring Kit (higher wattage)-S/S Controls.....	1
79*	14903	KIT - 900 SW ASSY 100V EM Top CD.....	1
79*	14904	KIT - 900 SW ASSY 100V EM Rear CD.....	1
79*	14905	KIT - 900 Switch ASSY 100V EM	1
79*	14906	KIT - 900M Wiring 100V CDT.....	1
A 83*	ME90-003	Relay - 12V Coil 20A 240Vac - CE.....	1
HHC-900/903 CDT Only - 13, 10, 6 & 5 Timers			
3	37147	Rear Panel Assy.	1
5	37556	Power Cord Assy.	1
A 63	43768	Power Switch.....	1
69	37395	Control Panel Weld Assy - 903 - 6 Timer.....	1
69	37285	Control Panel Weld Assy - Vented.....	1
69	30951	Control Panel Weld Assy - Not Vented.....	1
B 72	54577	Assy-Temperature Sensor (Boston Market)	1
B 72	29523	Probe Assy.	1
A 80	83758	Control PCB - 3 digit - 13 Timer (SN:DA1005053 and above).....	1
A 80	83760	Control PCB - 3 digit - 5 Timer (SN:DA1005053 and above).....	1
A 80*	140115	Kit- Control PCB - 3 digit - 13 Timer (SN: GV083IE - DA1005052)	1
	83761	Control PCB - 3 digit - 13 Timer.....	1
A 80*	140116	Kit- Control PCB - 3 digit - 5 Timer (SN: GV083IE - DA1005052)	1
	83762	Control PCB - 3 digit - 5 Timer	
A 80*	31910RB	Display PC Board Assy - 2 digit - 13 Timer; GV082IE and below...	1
A 80*	37374RB	Display PC Board Assy - 2 digit - 6 Timer; GV082IE and below.....	1
A 80*	73970RB	Display PC Board Assy - 3 digit - 10 Timer (McD's 903)	1

√ recommended parts/*not shown

UL & CE Approved - HHC-900/902/903/904/906/908

<u>Item No.</u>	<u>Part No.</u>	<u>Description</u>	<u>Quantity</u>
A 81*	78082RB	Control PC Board Assy - 3 digit - 10 Timer (McD's 903).....	1
A 81*	73968RB	Control PC Board Assy-2 digit-5 & 13 Timer; GV082IE and below	1
A 81*	70047RB	Control PC Board Assy - 2 digit - 6 Timer; GV082IE and below.....	1
B 82*	40500	Replaceable Beeper-3 Digit; GV083IE and above	1
B 82*	36210	Replaceable Beeper-2 Digit; GV082IE and below	1
A 83*	ME90-003	Relay 12V coil	1
A 84*	30978	Transformer 115V	1
A 84*	92406	Transformer 240V	1
98*	14871	KIT - 903 CVSRN 5CDT to 10CDT (Front to Back).....	2
99*	14885	KIT - 903 CVSRN 5CDT to 10CDT (Front to Front)	2
100*	14774	KIT - 900 120V KFC PRGM THERM.....	1
101*	14775	KIT - 900 230/240V KFC PRGM THERM.....	1
102*	14918	KIT - 903 CVSRN - STACKED.....	1
HHC-900 CDT Decals			
68	33874	Decal - KFC Vented - 3 digit	1
68	43952	Decal - KFC Non Vented - 3 digit.....	1
68	30950	Decal - GM 900 - 3 digit.....	1
68	31901	Decal - 903 - 6 Timer - Vented - 2 digit.....	1
68	31931	Decal - 903 - 6 Timer - Non Vented - 2 digit.....	1
68	52347	Decal - GM 903 - 5 Timer - 3 digit.....	1
68	55180	Decal - 13 Timer - 903 - 3 digit (Churches).....	1
68	61443	Decal - 900 Pollo Campero.....	1
HHC-900 CDT-5 Timers-KFC			
68	43073	Control Panel Decal	1
A 80*	51117RB	Display PC Board	1
	140115	Kit-HC90X 13 Timer Replacement	1
	140116	Kit-HC90X 5 Timer Replacement	1
A 81*	39167RB	--Control PC Board.....	1
B 82*	40500	Replaceable Beeper.....	1
A 84*	30978	Transformer.....	1
Boston Market HHC-900			
68	54511	Decal	1
A 72	54577	Temperature Sensor Assy.....	1
A 81*	54571	PC Board Assy.	1
A 83*	40645	Relay	1
A 84*	30978	Transformer.....	1
SimpleHold - HHC-900			
A 61	51278	Heater 120V/750W	1
68	69894	Decal	1
A 72	29523	Temperature Sensor Assy.....	1
A 81*	69843	PC Board Assy.	1
A 83*	40645	Relay	1
A 84*	30978	Transformer.....	1

√ recommended parts/*not shown

UL & CE Approved - HHC-900/902/903/904/906/908

<u>Item No.</u>	<u>Part No.</u>	<u>Description</u>	<u>Quantity</u>
C.E. Parts			
5	44857	Power Cord Assy.....	1
A 63	52224	Rocker Switch - CDT - CE	1
A 63	43768	Power Switch - Plastic	1
68	49038	Decal - Control Panel - HHC-900.....	1
68	49060	Decal - Control Panel-Vented-HHC-903	1
68	49086	Decal - Control Panel-KFC-HHC-900.....	1
68	49118	Decal - Control Panel-w/Vent-HHC-906/908	1
Vented Control Module			
85*	48990	Rear Panel Studweld Assy (Full) 900	1
85*	25944	Rr Pnl Studweld Assy (1/3) 903 (SN: DA0506014 & below) ..	1
85*	68859	Rear Panel Studweld Assy (1/3) 903 (SN: DA0506015 & up).	1
85*	28123	Rear Panel Studweld Assy-906/908	1
86*	28155	Cable - E/M.....	1
86*	25950	Cable - CDT	1
87*	25964	Hose - Intake	1
88*	25963	Hose - Exhaust	1
89*	25977	Hose Clamp.....	4
90*	25942	Coupling - Hose	1
91*	25999	Control Panel Stud Assy	1
92*	38429	Vent Control Arm.....	1
93*	38367	Knob - Vented Module.....	1
94*	27927	Spacer - Slide Vent (SN: DA0506014 & below)	1
94*	68574	Spacer - Slide Vent (SN: DA0506015 & above).....	1
95*	27828	Slide - Vent - Back (SN: DA0506014 & below).....	1
96*	28092	Slide - Vent - Blower - Box (SN: DA0506014 & below).....	1
97*	25919	Slide - Vent (SN: DA0506014 & below)	1
97*	68573	Slide - Vent (SN: DA0506015 & above)	1

√ recommended parts/*not shown

UL & CE Approved - HHC-900/902/903/904/906/908

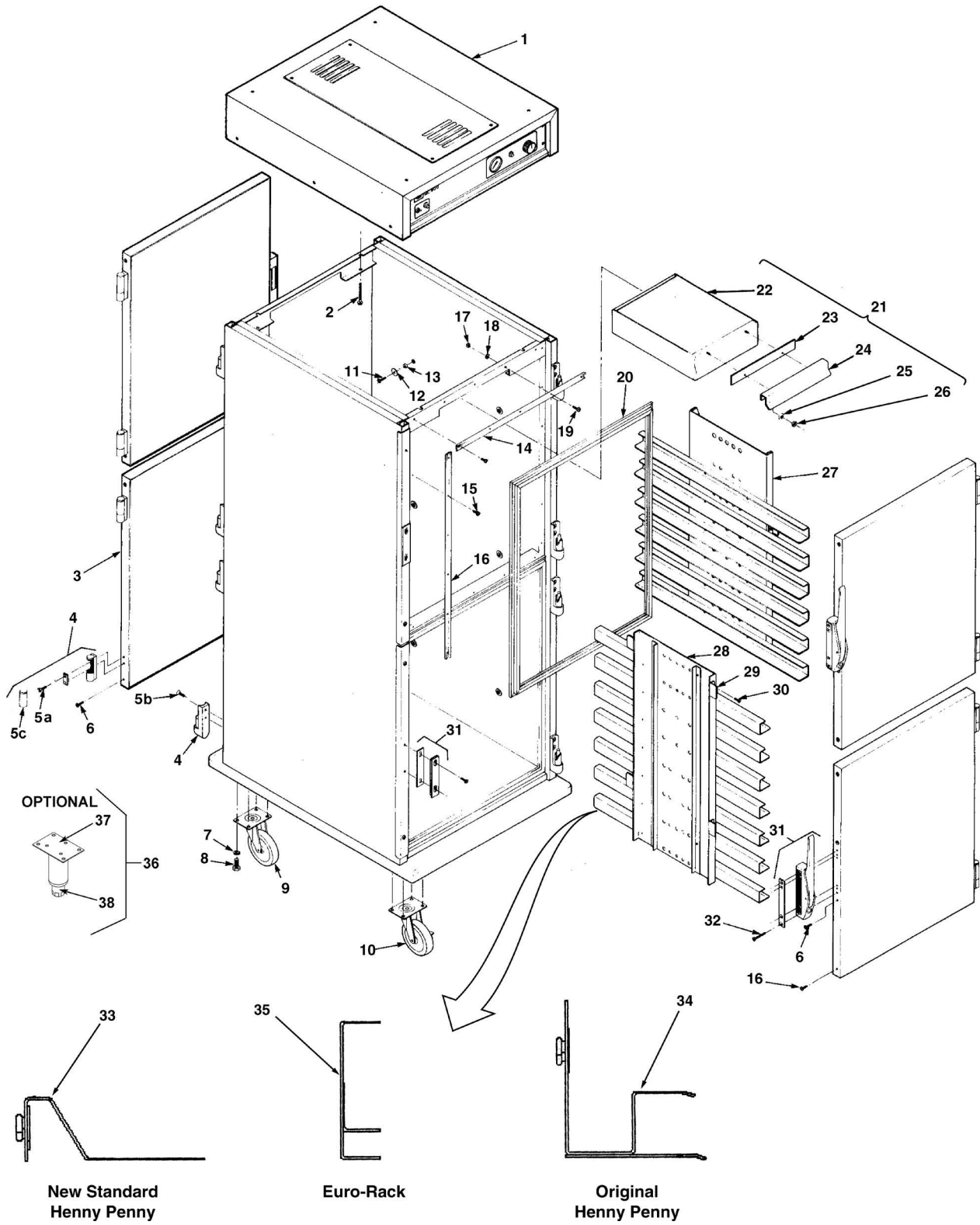

Figure 3-2. Cabinet Assembly - UL & CE Approved

UL & CE Approved - HHC-900/902/903/904/906/908

<u>Figure No.</u> <u>& Item No.</u>	<u>Part No.</u>	<u>Description</u>	<u>Quantity</u>
3-2		Cabinet Assembly - UL & CE Approved	
1	Contact HP	Control Module 120V, 2,000W.....	1
1	Contact HP	Control Module 120V, 1,500W, HHC-903	1
1	Contact HP	Control Module 120V, 2,000W, HHC-906, HHC-908.....	1
2	SC01-170	Screw #10-32 x 2-1/2 PH PHD.....	4
3	28816	Right Hand Top Door Assembly.....	1
3	28817	Right Hand Bottom Door Assembly.....	1
3	28818	Left Hand Top Door Assembly.....	1
3	28819	Left Hand Bottom Door Assembly.....	1
3	27033	Right Door Assembly, HHC-903	1
3	27034	Left Door Assembly, HHC-903	1
3	28158	Right Hand Top Door Assembly, HHC-906	1
3	85644	Left Hand Top Door Assembly, HHC-906.....	1
3	85645	Right Hand Bottom Door Assembly, HHC-906	1
3	85646	Left Hand Bottom Door Assembly, HHC-906.....	1
3	28166	Right Hand Door Assembly, HHC-908	1
3	28168	Left Hand Door Assembly, HHC-908.....	1
4	14271	Kit - HHC-900 Hinge	8
5a	SC01-086	Screw #10-32 x 1 PH TH S.....	16
5b	SC01-225	Screw #10-32 x 3/4 PH TH S	24
5c	27146	Cover - Hinge Pin - Chrome.....	8
6	SC01-074	Screw #10-32 x 1/2 PH TH.....	16
7a	LW01-002	Lockwasher Split 1/4".....	8
7b*	WA01-013	Flat Washer 1/4".....	8
8a	SC01-039	Screw 1/4-20 x 1 Hex Head.....	8
8b	SC01-193	Screw 1/4-20 x 3/4" Hex Head.....	8
9a	27155	Caster 5" (See item 52).....	2
9b	40948	Caster-4"; Rigid (See item 51).....	2
9c	58139	Caster-3" Dia.; 4" Height; Rigid (See item 50).....	2
9d	18645	Caster 2-1/2".....	2
9e	68804	Caster 5" - CE.....	2
9f	28170	Caster 5" Non-Swivel HHC-906, HHC-908.....	2
9g	19004	Caster 2".....	4
9h	78671	Caster 1.5" - Swivel.....	4
10a	27154	Caster 5" W/Brake (See item 52).....	2
10b	40947	Caster-4"; Swivel W/Brake (See item 51).....	2
10c	58138	Caster-3" Dia.; 4" Height; Swivel W/Brake (See item 50).....	2
10d	18646	Caster 3" W/Brake.....	2
10e	68803	Caster 5" W/Brake - CE.....	2
11	SC01-075	Screw #10-32 x 3/. PHT TH	12
12	25695	Washer.....	12

√ recommended parts/*not shown

UL & CE Approved - HHC-900/902/903/904/906/908

<u>Item No.</u>	<u>Part No.</u>	<u>Description</u>	<u>Quantity</u>
13	25644	Spacer.....	12
14	25687	Retainer, HHC-900; HHC-903	8 & 4
14	28117	Retainer, HHC-906; HHC-908	8 & 4
15	SC02-041	Screw #8-18 x 7/16 PH IND XTRNL TORX.....	24
16	25689	Retainer, HHC-900	8
16	25690	Retainer, HHC-903	4
17	NS01-008	Nut #8-32 Hex S	10
18	LW02-006	Lockwasher Internal #8 S	10
19	SC01 -053	Screw #8-32 x 1/2 PH RHD.....	10
B 20	25643	Gasket Door	4
B 20	25793	Gasket - Door, HHC-903	4
B 20	28147	Gasket - Door, HHC-906	2
B 20	28143	Gasket - Door, HHC-908	1
21	71478	Water Box Assembly with Handle - HHC-903 - Flip Doors	1
21	25879	Water Box Assembly with Handle	1
22	25707	Water Box and Stud Assembly	1
22	70381	Water Box and Stud Assembly - HHC-903 - Flip Doors....	1
23	25646	Wiper.....	1
24	25685	Pull.....	1
25	LW02-005	Lockwasher Internal #10	2
26	NS03-030	Nut Acorn #10-32	2
27	27895	Air Duct Assembly - Upper	2
27	42964	Air Duct Assembly - Upper - HHC-900K (SIB)	2
27	52345	Air Duct -Upper-KFC-Int'l-CDT-15 Tray	2
27	25957	Air Duct Assembly - HHC-903.....	2
27	70387	Air Duct Assembly - HHC-903 - Flip Doors	2
27	70032	Air Duct Assembly - HHC-903 - Pollo Campero	2
27	34928	Air Duct Assembly- Upper - Boston Mkt.	2
27	55181	Air Duct Assembly- Upper- Churches	2
27	55087	Air Duct Assembly-Upper-Wendy's #10	2
27	28129	Air Duct-Upper ONLY-NO SLIDES HHC-906 (uses 28133 slides)	2
27	34519	Air Duct-Upper ONLY-NO SLIDES-Knotts Berry-HC-906 (uses 34536 slides)	2
28	55088	Air Duct Assembly-Lower-Wendy's #10	2
28	55084	Air Duct Assembly-Wendy's-903 Plast.	2
28	27811	Air Duct Assembly - Lower	2
28	55187	Air Duct Assembly- Lower-Churches.....	2
28	34929	Air Duct Assembly-Lower-Boston Mkt.....	2
28	52346	Air Duct-Lower-KFC-Int'l-CDT-15 Tray.....	2
28	42965	Air Duct Assembly - Lower HHC-900K(SIB)	2
28	28130	Air Duct ONLY-NO SLIDES - Lower HHC-906 (uses 28133 slides)	2
28	34517	Air Duct -Lower ONLY-NO SLIDES-Knotts Berry-HC-906 (uses 34536 slides)	2
28	28128	Air Duct ONLY-NO SLIDES - HHC-908 (uses 28133 slides).	2
28	34553	Air Duct ONLY-NO SLIDES-Knotts Berry-HC-908 (uses 34536 slides)	2

√ recommended parts

UL & CE Approved - HHC-900/902/903/904/906/908

<u>Item No.</u>	<u>Part No.</u>	<u>Description</u>	<u>Quantity</u>
29	25696	Hanger.....	16
30	SC02-023	Screw #8-B x 3/8 PH THD S.....	8
31	14272	Latch/Screw Kit.....	4
32	SC01-186	Screw #10-32 x 1-3/4 PH.....	16
33	34536	Slides ONLY - HHC-906, HHC-908.....	22 & 8
34	28133	Slides ONLY, HHC-906, HHC-908.....	22 & 8
35	34544	Air Duct Assembly Complete - HHC-908,.....	2
35	34545	Air Duct Assembly Complete - Lower - HHC-906.....	2
35	34550	Air Duct Assembly Complete - Upper - HHC-906.....	2
36	14647	Kit - Leg Adjustable - 4 inch (Set of 4 legs).....	1
36	68946	Legs - Adjustable - 4 inch.....	4
37	68937	Weld Assy - Mtg. Plate & Leg - 4 inch.....	4
38	26120	Foot - Adjustable.....	4
39	27149	Stop - Door.....	4
39	34949	Door Stop - Boston Mkt.....	4
40*	27146	Chrome Hinge Cover.....	1
41*	27912	Handle, HHC-906, HHC-908.....	1
42*	27939	Brkt. Handle, HHC-906, HHC-908.....	2
43*	58116	Hinge Plate (Tap Bar) HHC-900.....	4
44*	58274	Hinge Plate (Tap Bar) HHC-903.....	4
45*	03182	Worktop - HHC-903.....	1
46*	56179	Worktop - HHC-908.....	1
47*	14853	Kit - 903 Undercounter CVSRN.....	1
48*	58047	Insulation - Side.....	2
49*	03559	Accessory - Storage Bin.....	1
50*	86832	3" Caster Set (Includes items 7a, 7b, 8b, 9b, & 10b).....	1
51*	86833	4" Caster Set (Includes items 7a, 7b, 8b, 9c, & 10c).....	1
52*	86850	5" Caster Set (Includes items 7a, 8a, 9a, & 10a).....	1
Glass Doors Only			
3	54353	Glass Door Assembly - 1/3 size(LH).....	1
3	54352	Glass Door Assembly - 1/3 size(RH).....	1
--	30517*	Nut - Glass Retainer.....	4
3	59257	Glass Door Assy.-Left, Top.....	1
3	59258	Glass Door Assy.-Left, Bottom.....	1
3	59260	Glass Door Assy.-Right, Top.....	1
3	59261	Glass Door Assy.-Right, Bottom.....	1
3	76480	Glass Door Assy. - 1/2 size (McD's).....	1
Church's HHC-903			
3	54353	Glass Door Assembly - 1/3 size (LH).....	1
3	54352	Glass Door Assembly - 1/3 size (RH).....	1

* not shown

UL & CE Approved - HHC-900/902/903/904/906/908

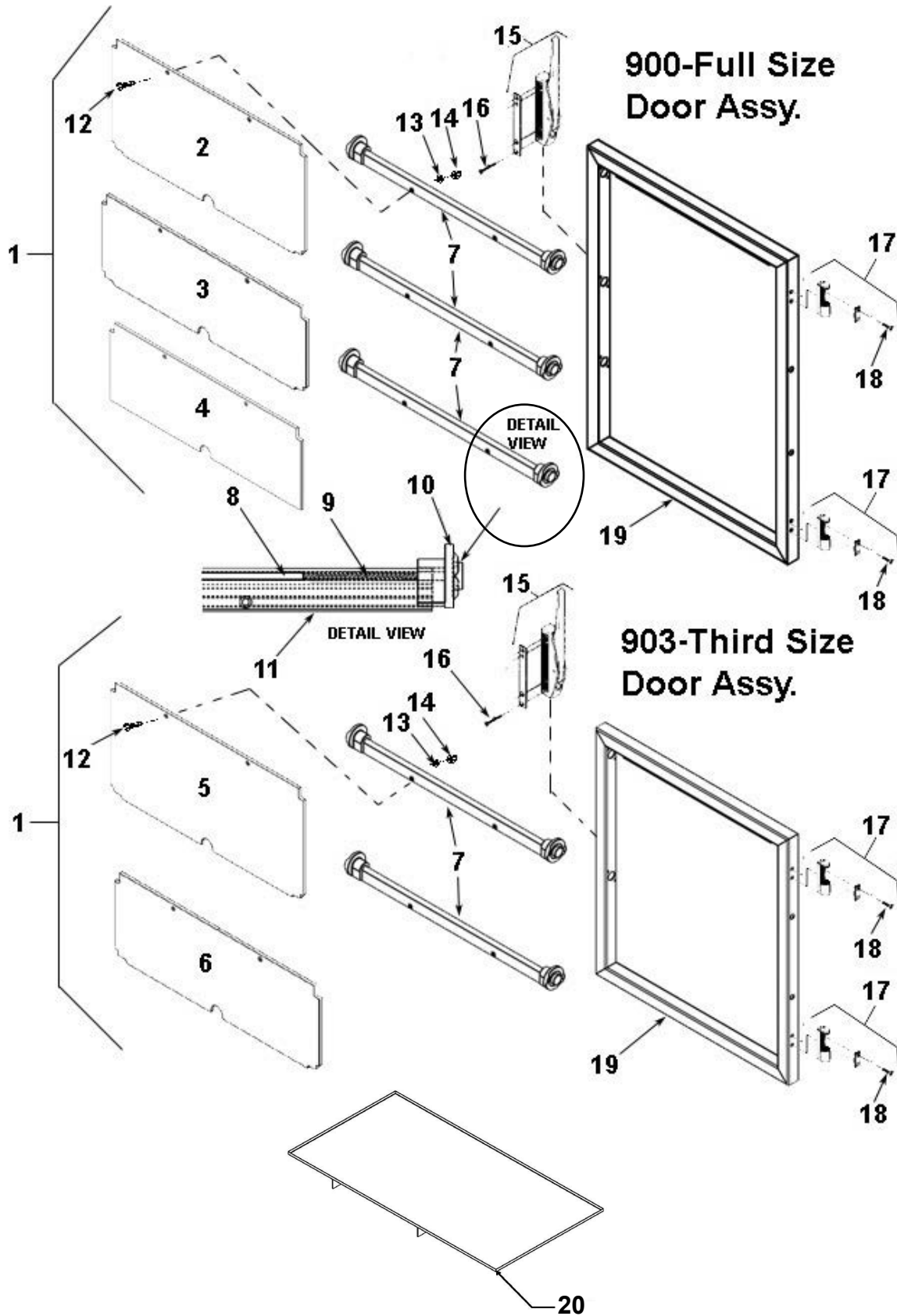

Figure 3-3. Flip-Up Door Assemblies (HHC-903 - SN: DA0511040 & Above)

UL & CE Approved - HHC-900/902/903/904/906/908

NOTICE

- HHC-903's (1/3-size) with SN: DA0511039 & below, **SN required.**
- HHC-900 (full-size) with SN: DA0511039 & below, **no parts available.**
Complete door assembly must be ordered.

<u>Figure No.</u> <u>& Item No.</u>	<u>Part No.</u>	<u>Description</u>	<u>Qty per Door</u>	
			<u>900</u>	<u>903</u>
3-3		Flip-Up Door Assemblies		
1	71309	Assy - Door - Flip - RH - Full Size	1	-
1	71403	Assy - Door - Flip - LH - Full Size	1	-
1	71466	Assy - Door - Flip - RH - 1/3 Size (DA0511040 & Above).....	-	1
1	71467	Assy - Door - Flip - LH - 1/3 Size (DA0511040 & Above).....	-	1
2	75544-004	Panel - Flip Door - 9.562 HGT.....	1	-
3	75544-003	Panel - Flip Door - 6.860 HGT.....	1	-
4	75544-005	Panel - Flip Door - 6.735 HGT.....	1	-
5	75544-001	Panel - Upper Flip Door - 1/3 Size.....	-	1
6	75544-002	Panel - Lower Flip Door - 8.108 HGT	-	1
7	71308	Assy - Hinge - Panel - Door - Flip.....	3	2
8	71067	Rod - Flip Door	3	2
9	71316	Spring - Flip Door	3	2
10	70768	Cam - Flip Door - RH.....	3	2
10	70769	Cam - Flip Door - LH.....	3	2
11	73320	Extrusion - Flip Door	3	2
12	SC01-032	Screw - #8-32 x 5/8 PH 100 FHD SS.....	6	4
13	LW02-006	Lockwasher - Internal - #8 S	6	4
14	NS03-024	Nut - #8-32 Low Crown Acorn - B P	6	4
15	14272	Kit - HC-900 Door Handle	1	1
16	SC01-186	Screw - #10-32 x 1-3/4 PH FHD SS.....	4	4
17	14271	Kit - HC-900 Door Hinge.....	2	2
18	SC01-086	Screw - #8-32 x 1 PH FHD S.....	4	4
19	71310	Weld Assy - Flip Door Frame - RH - Full Size	1	-
19	71404	Weld Assy - Flip Door Frame - LH - Full Size.....	1	-
19	71056	Weld Assy - Flip Door Frame - RH - 1/3 Size.....	-	1
19	71057	Weld Assy - Flip Door Frame - LH - 1/3 Size.....	-	1
20	03557	Accessory - Flip Door Tray	-	1

Non-UL & Non-CE Approved - HHC-900 EM, HHC-900 CDT, & HC-15

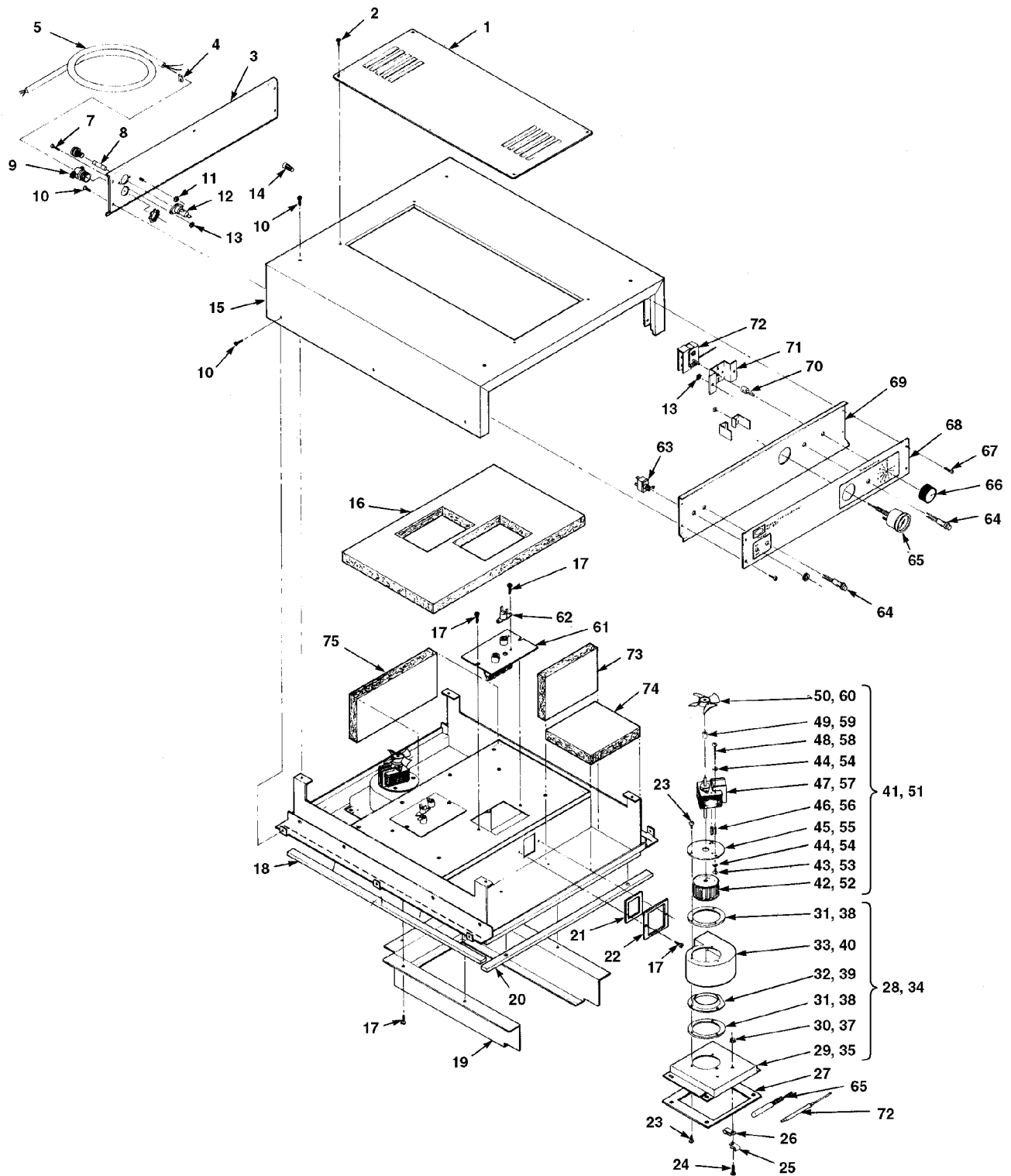

Figure 3-4. Control Module Assembly - Non-UL, Non-CE

Non-UL & Non-CE Approved - HHC-900 EM, HHC-900 CDT, & HC-15

<u>Figure No.</u> <u>& Item No.</u>	<u>Part No.</u>	<u>Description</u>	<u>Quantity</u>
3-4		Control Module Assembly - Non-UL, Non-CE	
1	72312	Panel - Access Louvers (HHC-900EM & HC-15).....	1
1	80890	Panel -Access Louvers (HHC-900CDT)	1
2	SC02-023	Screw #8-32 x 1/2 PH RHD.....	4
3	28029	Panel - Rear (208/240V) S/A (HHC-900EM).....	1
3	72404	Panel - Rear (120V) S/A (HHC-900CDT).....	1
3	72317	Panel Rear S/A (HC-15).....	1
4	EC04-004	Terminal Flag #10-10-12 Ga.....	1
5	31584	Power Cord Assy (HHC-900CDT).....	1
5	71384	Power Cord Assy-240V (HHC-900EM & HC-15).....	1
5	72532	ASSY-PWR CORD 120/30A TWIST LK	1
7	SC01-010	Screw #6-32 x 112 pH PHD	2
A 8	EF02-007	Fuse 15 Amp	1
9	49778	Connector - Cable 3/4	1
10	SC02-023	Screw 48-B x 3/8 pH THD	15
11	NS02-001	Nut #10-32 Hex Keys	1
A 12	EF02-006	Fuse Holder	1
13	NS02 005	Nut #6-32 Hex Keys	2
14	EC01-010	Wire Nut 12-18 Ga.....	2
15	72305	Top - Enclosure (HHC-900EM & HC-15).....	1
15	84607	Top - Enclosure (HHC-900CDT).....	1
16	26225	Insulation - Cover	1
17	SC02-041	Screw #8-18 x 7/16 PH IND XTRNL TORX.....	18
18	25620	Seal.....	2
19	25670	Cradle.....	1
20	25624	Seal.....	2
21	25619	Gasket - Blower Outlet	2
22	25618	Gasket Retainer	2
23	SC02-041	Screw #8-18 x 7/16 PH IND XTRNL TORX.....	2
24	SC01-074	Screw #10-32 x 3/4 Hex HD.....	2
25	EF02-031	Clamp 1/4 x 3/8" (HC-15)	2
26	EF02-003	Wire Tie.....	4
27	25627	Gasket	2
28	72915	Blower Box Assembly (HHC-900 EM & CDT).....	2
29	72914	Box, Blower (HHC-900 EM & CDT)	1
30	NS02-001	Nut.....	2
31	25698	Gasket, Blower Plate (HHC-900 EM & CDT).....	1
32	25622	Flange, Inlet (HHC-900 EM & CDT).....	1
33	25623	Housing, Blower (HHC-900 EM & CDT).....	1
34	87097	Blower Box Assembly (HC-15).....	2
35	72914	Rear Box, Blower (HC-15)	1
37	NS02-001	Nut.....	2
38	25698	Gasket, Blower Plate (HC-15)	2
39	25622	Flange, Inlet (HC-15).....	1
40	25623	Housing, Blower (HC-15).....	1

√ recommended parts

Non-UL & Non-CE Approved - HHC-900 EM, HHC-900 CDT, & HC-15

<u>Item No.</u>	<u>Part No.</u>	<u>Description</u>	<u>Quantity</u>
51	14249	Blower Motor Assembly (240V)	2
52	52240	Wheel, Blower, Int'l.....	1
53	SC01-023	Screw.....	4
54	LW02-010	Lockwasher	4
55	37157	Plate, Blower.....	1
56	81606	Spacer, Motor.....	4
A 57	25752	Motor (240V).....	1
58	SC01-091	Screw.....	4
59	25768	Spacer, Fan.....	1
A 60	25706	Fan, Cooling.....	1
A 61	51279	Heater 120V/1000W	2
A 62	18201	High Limit Thermostat.....	2
A 63	95230	Power Switch (HHC-900EM & HC-15).....	1
A 63	72277	Black Rocker Switch (HHC-900CDT).....	1
B 64	16624	Indicator Light - Red (HHC-900EM & HC-15)	2
A 65	14250	Thermometer (HHC-900 EM & HC-15)	1
66	25863	Knob - Thermostat	1
67	SC02-030	Screw #8-B x 3/8 PH THD Black Oxide	4
68	44204	Decal-Control (HHC-900EM)	1
68	85249	Decal-Control (HHC-900CDT)	1
68	87065	Decal-Control (HC-15)	1
69	72440	Panel Control S/A (HHC-900EM & HC-15).....	1
69	81307	Panel Control S/A (HHC-900CDT).....	1
71	25241	Bracket Thermostat Mount	1
A 72	14209	Thermostat w/clips.....	1
73	25734	Insulation 5 x 7 x 1.....	2
74	25733	Insulation 6 x 6 1/2 x 1	4
75	25735	Insulation 5 x 10 1/2 x 1	2
A 80*	83758	Control & Display PCB Assy - 13 Timer (HHC-900CDT)	1
A 83*	ME90-009	Relay 240V coil, 30A (HHC-900CDT)	1
A 84*	92406	Transformer 240V (HHC-900CDT)	1
103*	27870	Insulator, Fan Motor	1

√ recommended parts/* not shown

Non-UL & Non-CE Approved - HHC-900 EM, HHC-900 CDT, & HC-15

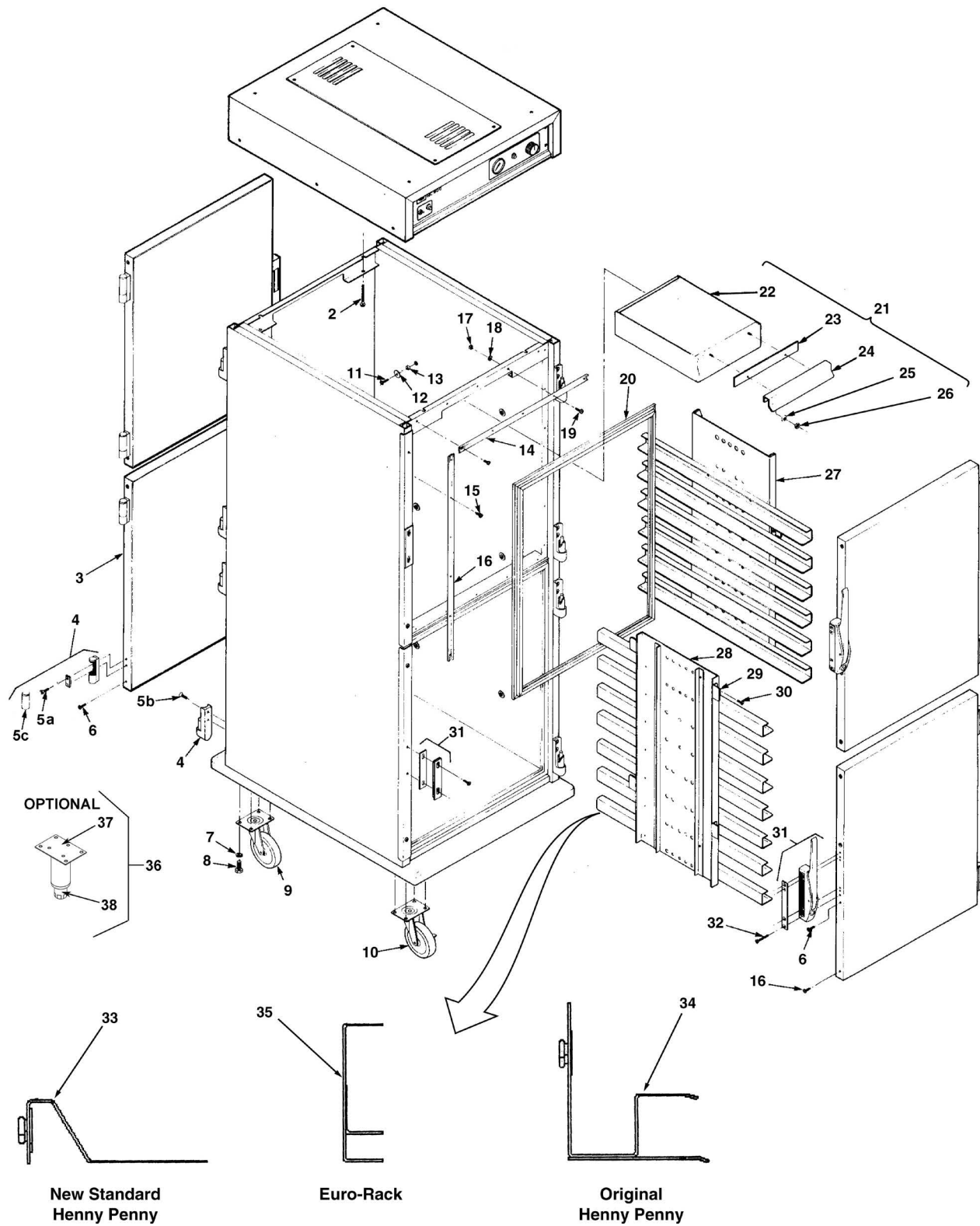

Figure 3-5. Cabinet Assembly - Non-UL, Non-CE

Non-UL & Non-CE Approved - HHC-900 EM, HHC-900 CDT, & HC-15

<u>Figure No.</u> <u>& Item No.</u>	<u>Part No.</u>	<u>Description</u>	<u>Quantity</u>
3-5		Cabinet Assembly - Non-UL, Non-CE	
2	SC01-170	Screw #10-32 x 2-1/2 PH PHD.....	4
2*	LW02-004	Lockwasher.....	4
2*	WA01-022	Flat Washer.....	2
2*	37151	Spacer (HHC-900EM & HC-15).....	2
3	59257	Glass Door Assy.-Left, Top.....	1
3	59258	Glass Door Assy.-Left, Bottom.....	1
3	59260	Glass Door Assy.-Right, Top.....	1
3	59261	Glass Door Assy.-Right, Bottom.....	1
4	14271	Kit - Hinge.....	8
5a	SC01-086	Screw #10-32 x 1 PH TH S.....	16
5b	SC01-225	Screw #10-32 x 3/4 PH TH S.....	24
5c	27146	Cover - Hinge Pin - Chrome.....	8
6	SC01-074	Screw #10-32 x 1/2 PH TH.....	16
7	LW01-002	Lockwasher Split 1/4".....	8
8	SC01-104	Screw 1/4-20 x 1-1/2" Hex Head.....	8
9	72365	Caster 5".....	2
10	72364	Caster 5" W/Brake.....	2
11	SC01-075	Screw #10-32 x 3/. PHT TH.....	12
12	25695	Washer.....	12
13	25644	Spacer.....	12
14	25687	Retainer.....	8 & 4
15	SC02-041	Screw #8-18 x 7/16 PH IND XTRNL TORX.....	24
16	25689	Retainer.....	8
17	NS01-008	Nut #8-32 Hex S.....	10
18	LW02-006	Lockwasher Internal #8 S.....	10
19	27944	Cap Screw #8.....	10
B 20	25643	Gasket Door.....	4
21	72405	Water Box Assembly with Handle.....	1
22	72406	Water Box and Stud Assembly.....	1
23	25646	Wiper.....	1
24	25685	Pull.....	1
25	LW02-005	Lockwasher Internal #10.....	2
26	NS03-030	Nut Acorn #10-32.....	2
27	27895	Air Duct Assembly - Upper (HHC-900CDT).....	2
27	52345	Air Duct -Upper-15 Tray (HHC-900EM & HC-15).....	2
28	27811	Air Duct Assembly - Lower (HHC-900CDT).....	2
28	52346	Air Duct-Lower-15 Tray (HHC-900EM & HC-15).....	2
31	14272	Latch/Screw Kit.....	4
32	SC01-186	Screw #10-32 x 1-3/4 PH.....	16
39	27149	Stop - Door (HHC-900EM & HHC-900CDT).....	4
48*	58047	Insulation - Side.....	1
53*	72366	Plate - Caster (HHC-900EM).....	4

√ recommended parts / * not shown

