



**Henny Penny
Island Warmer
Model HMI-103
Model HMI-105**

TECHNICAL MANUAL

TABLE OF CONTENTS

Section	Page
Section 1. TROUBLESHOOTING	1-1
1-1. Introduction	1-1
1-2. Safety	1-1
1-3. Troubleshooting	1-2
Section 2. MAINTENANCE.....	2-1
2-1. Introduction	2-1
2-2. Test Instruments.....	2-1
2-3. Fuse.....	2-1
2-4. Radiant Heaters.....	2-2
2-5. Light Socket.....	2-2
2-6. Air Heaters.....	2-3
2-7. Power Switch.....	2-3
2-8. Infinite Regulator.....	2-4
2-9. High Limit	2-5
2-10. Front Glass Removal	2-6
2-11. Slide Glass Removal.....	2-7
2-12. Cooling Fans.....	2-7
2-13. Contactor	2-8
2-14. Wiring Diagrams	2-9
Section 3. PARTS INFORMATION.....	3-1
3-1. Introduction	3-1
3-2. Genuine Parts.....	3-1
3-3. When Ordering Parts	3-1
3-4. Prices	3-1
3-5. Delivery	3-1
3-6. Warranty	3-1
3-7. Recommended Spare Parts for Distributors	3-1

SECTION 1. TROUBLESHOOTING

1-1. INTRODUCTION

This section provides troubleshooting information in the form of an easy to read table.

If a problem occurs during the first operation of a new cabinet, recheck the Installation Section of the Operator's Manual.

Before troubleshooting always recheck the Operating Instructions Section of the Operator's manual.

1-2. SAFETY

Where information is of particular importance or is safety related, the words NOTICE, CAUTION, or WARNING are used. Their usage is described below.



SAFETY ALERT SYMBOL is used with **DANGER**, **WARNING**, or **CAUTION** which indicates a personal injury type hazard.

NOTICE

NOTICE is used to highlight especially important information.

CAUTION

CAUTION used without the safety alert symbol indicates a potentially hazardous situation which, if not avoided, may result in property damage.

 **CAUTION**

CAUTION used with the safety alert symbol indicates a potentially hazardous situation which, if not avoided, may result in minor or moderate injury.

 **WARNING**

WARNING indicates a potentially hazardous situation which, if not avoided, could result in death or serious injury.

1-3. TROUBLESHOOTING

To isolate a malfunction proceed as follows:

1. Clearly define the problem or symptom.
2. Locate the problem in the troubleshooting table.
3. Review all possible causes, then work through the list of corrections one-at-a-time until the problem is solved.

CAUTION

Refer to maintenance procedures in Section 2 to safely and properly make the checkout and repair needed.

PROBLEM	CAUSE	CORRECTION
OPERATIONS		
Product not holding temperature	<ul style="list-style-type: none"> • Product held too long • Radiant heat too low • Radiant heat not working • Air heat too low • Air heaters not working • High limit open 	<ul style="list-style-type: none"> • Only hold product for specified times • Turn to a higher setting • Check radiant heaters per Radiant Heaters Section • Turn to a higher setting • Check heaters per Air Heaters Section • Check cooling fan • Check high limits
LIGHTING		
A. Lights will not turn on	<ul style="list-style-type: none"> • Defective fuse • Faulty switch • No neutral supplied in field wiring • Loose or defective wiring 	<ul style="list-style-type: none"> • Check fuse and replace if necessary • Check switch and replace if necessary • Check field wiring to be sure a true neutral has been connected • Check wiring and repair or replace if necessary

1-3. TROUBLESHOOTING (Continued)

PROBLEM	CAUSE	CORRECTION
B. Not all lights turn on	<ul style="list-style-type: none"> • Faulty light bulb • Faulty light socket • Faulty switch 	<ul style="list-style-type: none"> • Replace with recommended bulb • Replace socket per Light Socket Section • Check switch and replace if necessary
HEATING SECTION		
A. Radiant heat not working	<ul style="list-style-type: none"> • Faulty infinite regulator • Faulty power switch • Faulty heater • Faulty contactor • High limit opened 	<ul style="list-style-type: none"> • Replace infinite regulator per Infinite Regulator Section • Check switch and replace if necessary • Check heater and replace if necessary • Check contactor and replace if necessary • Check cooling fans • Check high limits (reset)
B. Air heat not working	<ul style="list-style-type: none"> • Faulty infinite regulator • Faulty power switch • Faulty heater • Faulty contactor • High limit opened 	<ul style="list-style-type: none"> • Replace infinite regulator per Infinite Regulator Section • Check switch and replace if necessary • Check heater and replace if necessary • Check contactor and replace if necessary • Check cooling fans • Check high limits (reset)

SECTION 2. MAINTENANCE

2-1. INTRODUCTION

This section provides procedures for check out and replacement of the various parts used within the cabinet. Before replacing any parts, refer to the Troubleshooting Section. It will aid you in determining the cause of the malfunction.

2-2. TEST INSTRUMENTS

You may want to use two test instruments to check the electric components.

1. A continuity light
2. An ohmmeter

When the manual refers to a circuit being closed, the continuity light will be illuminated or the ohmmeter should read zero unless otherwise noted.

When the manual refers to a circuit being open, the continuity light will not illuminate or the ohmmeter will read 1 (one) or infinite resistance.

NOTICE

A continuity tester cannot be used to check coils.

2-3. FUSE

1. Remove electrical power supplied to the unit.

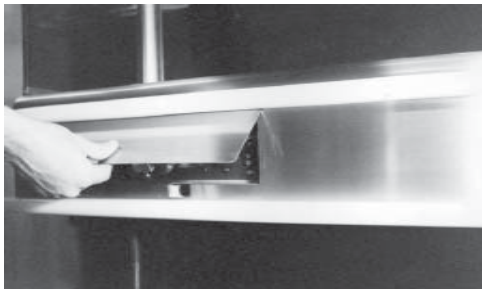

Step 2



To avoid electrical shock or property damage, move power switch to OFF and disconnect main circuit breaker, or unplug cord at wall receptacle.



Step 3

2. Open the control panel cover and locate both fuse holders.
3. Unscrew the caps, counterclockwise, and pull fuses from holders.
4. Place leads of meter on each end of a fuse, and check for continuity on both fuses. If one shows an open circuit, replace it with a 15 amp fuse (HP no. EF02-007).

2-4. RADIANT HEATERS



Step 2



Step 3



Step 4

2-5. LIGHT SOCKET

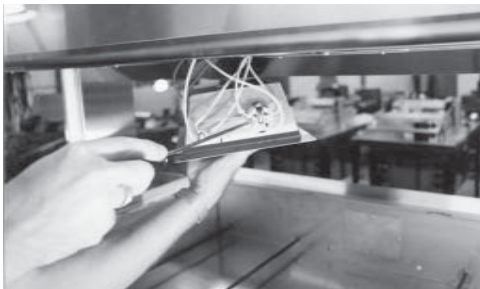

Step 3



Step 4

1. Remove electrical power supplied to the unit.



To avoid electrical shock or property damage, move power switch to OFF and disconnect main circuit breaker, or unplug cord at wall receptacle.

2. Remove screws from access panel on both sides of radiant heater and let light socket and heater hang down.
3. Remove screw from inner side of access panel.
4. Remove wires from heater; pull radiant heater from panel.
5. Install new radiant heaters.



The radiant heaters are paired and wired in series. If one heater is bad, two won't heat.

1. Remove electrical power supplied to the unit.



To avoid electrical shock or property damage, move power switch to OFF and disconnect main circuit breaker, or unplug cord at wall receptacle.

2. Remove screws from access panel on both sides of light as shown above in the Radiant Heaters Section.
3. Remove wires from light socket.
4. Depress retainer on light socket and push through panel.
5. Install new light socket.

2-6. AIR HEATERS



Step 3



Step 5

2-7. POWER SWITCH



Step 2

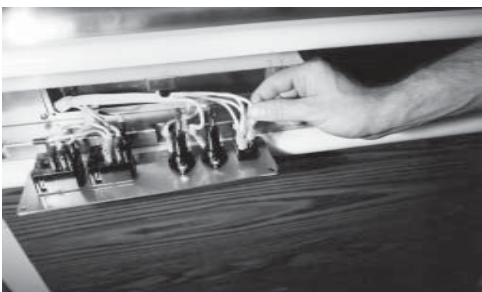

Step 3

1. Remove electrical power supplied to the unit.



To avoid electrical shock or property damage, move power switch to OFF and disconnect main circuit breaker, or unplug cord at wall receptacle.

2. Remove pans and pan supports from unit.
3. Remove heater screws from inside of well.
4. Pull heater terminals out into interior of unit to access wires.
5. Remove wires from heater and pull heater from unit.
6. Install new heater.

1. Remove electrical power supplied to the unit.



To avoid electrical shock or property damage, move power switch to OFF and disconnect main circuit breaker, or unplug cord at wall receptacle.

2. Open control panel cover and remove the four screws securing the control panel.
3. Pull control panel out to access back of switch. Pull and label the wires of switch.

2-7. POWER SWITCH (Continued)

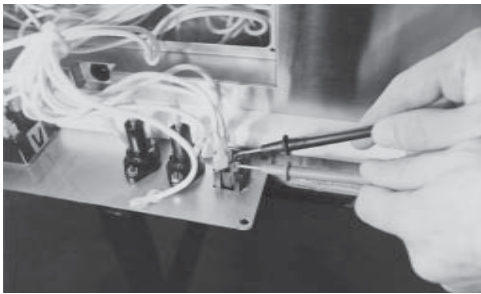

Step 4

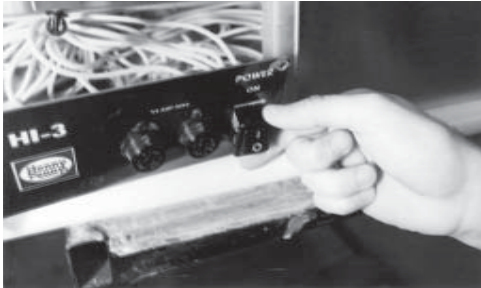

Step 5

4. Check across top and bottom terminals for continuity. With the switch in the ON position, the circuit should be closed. If not, replace switch by following the next steps.
5. Push in on the tabs at the ends of the switch and pull switch out from front of the control panel.
6. Replace with new switch.

2-8. INFINITE REGULATOR

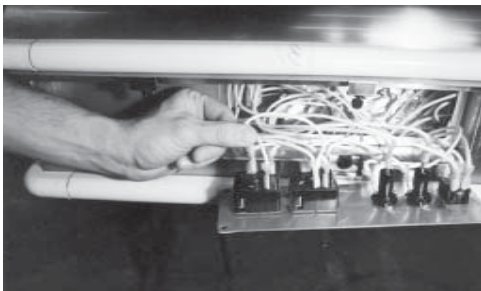

Step 3



Step 4

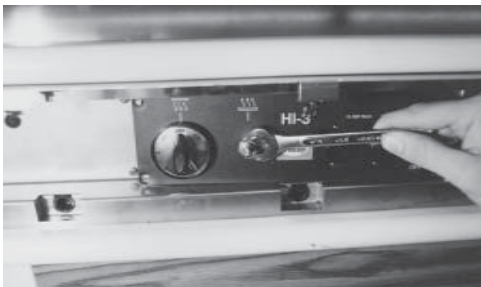

Step 5

1. Remove electrical power supplied to the unit.



To avoid electrical shock or property damage, move the power switch to OFF and disconnect main circuit breaker, or unplug cord at wall receptacle.

2. Open control panel cover and remove four screws securing the control panel.
3. Pull control panel out to access back of regulator. Pull and label wires from regulator.
4. Pull out on regulator knob and remove the knob from front of control panel.
5. Using a 5/8 wrench unscrew the nut on the front of control panel, securing the regulator, and remove the regulator.
6. Install new infinite regulator.

2-9. HIGH LIMIT



Step 2

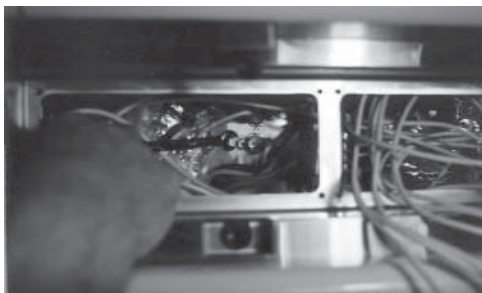

Step 4



Cooling Fan High Limit

1. Remove electrical power supplied to the unit.



To avoid electrical shock or property damage, move power switch to OFF and disconnect main circuit breaker, or unplug cord at wall receptacle.

2. Open the control panel cover and remove the four screws securing the access panel, and remove panel.
3. Pull wires from high limit and check for continuity across terminals on high limit. If meter shows open circuit, with unit cooled down, replace high limit, following next steps.
4. Remove the two nuts securing the high limit and pull high limit from unit.
5. Install new high limit.

NOTICE

The cooling fan high limits are located behind access panels in center of unit, one on each side. (See photo.) These high limits must be manually reset. Then test high limits, per above steps. Make sure fans are functioning properly also.

2-10. FRONT GLASS REMOVAL



Step 1

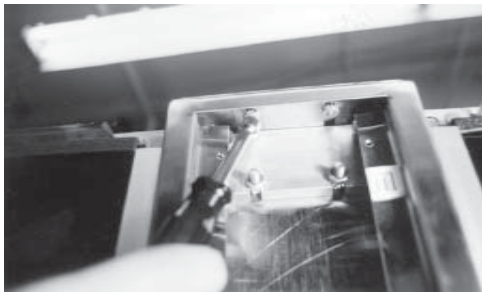

Step 2



Step 3

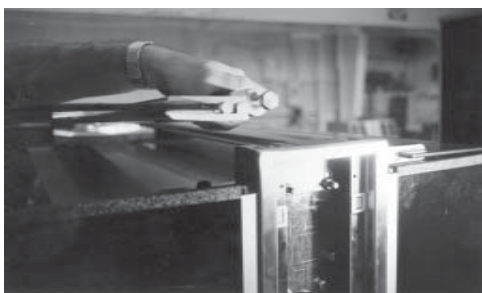

Step 4

1. Using a flat blade screwdriver, remove both end panels.

2. Using a Phillips head screwdriver, remove screws securing inner panel on control end, and remove panel.

3. Remove nuts securing hinge brackets and remove brackets.

4. Lift front glass assembly from unit.

2-11. SIDE GLASS REMOVAL

1. Remove front glass assy. per Front Glass Removal Section.
2. Pull side of glass straight up and out of brackets.

2-12. COOLING FANS

1. Remove electrical power supplied to the unit.



To avoid electrical shock or property damage, move power switch to OFF and disconnect main circuit breaker, or unplug cord at wall receptacle.

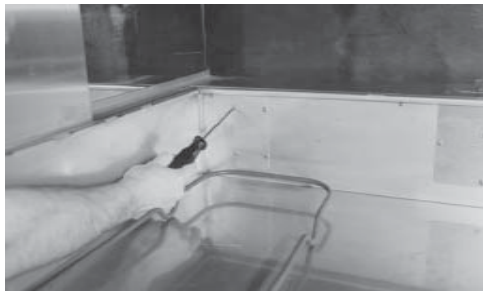

Step 3

2. Remove the pans and pan supports from unit.

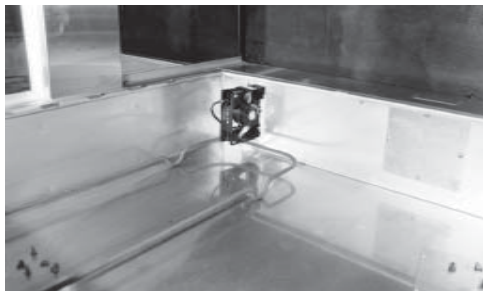

Step 4

3. Remove four screws securing the access panel and remove panel.
4. Slide cooling fan and bracket out of unit.
5. Remove cooling fan from bracket.
6. Install new cooling fan in reverse order.

2-13. CONTACTOR

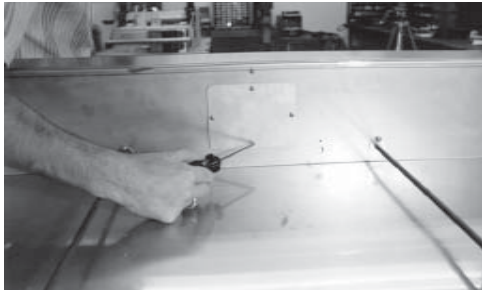

Step 3

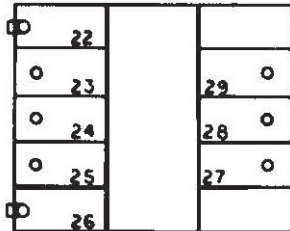

Steps 5 and 7



Step 6

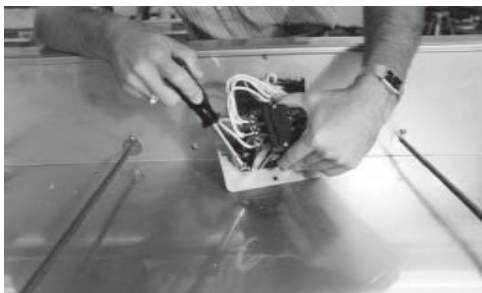

Step 8

1. Remove electrical power supplied to the unit.



To avoid electrical shock or property damage, move power switch to OFF and disconnect main circuit breaker, or unplug cord at wall receptacle.

2. Remove the pans and pan supports from unit.
3. Remove the four screws securing the access panel and remove panel.



To avoid electrical shock, make connections before applying power, take reading, and remove power before removing meter leads. The following checks are performed with wall circuit breaker closed and main power switch in the ON position.

4. With power reappplied, set infinite regulator to its highest setting.
5. Perform checks on the contactor as follows:

<u>Test Points</u>	<u>Results</u>
From terminal 27 to 28	The voltage should read the same at each terminal and
From terminal 28 to 29	should correspond to voltage rating stated on data plate.
From terminal 27 to 29	

6. Remove electrical power supplied to unit and remove and label wires from contactor.

7. Perform checks on contactor as follows:

<u>Test Points</u>	<u>Results</u>
From 23 to 29	open circuit
From 24 to 28	open circuit
From 22 to 26	open circuit
	ohm reading 415

8. If contactor is defective, remove screws securing contactor and remove contactor from unit.

9. Install new contactor.

2-14. WIRING DIAGRAMS

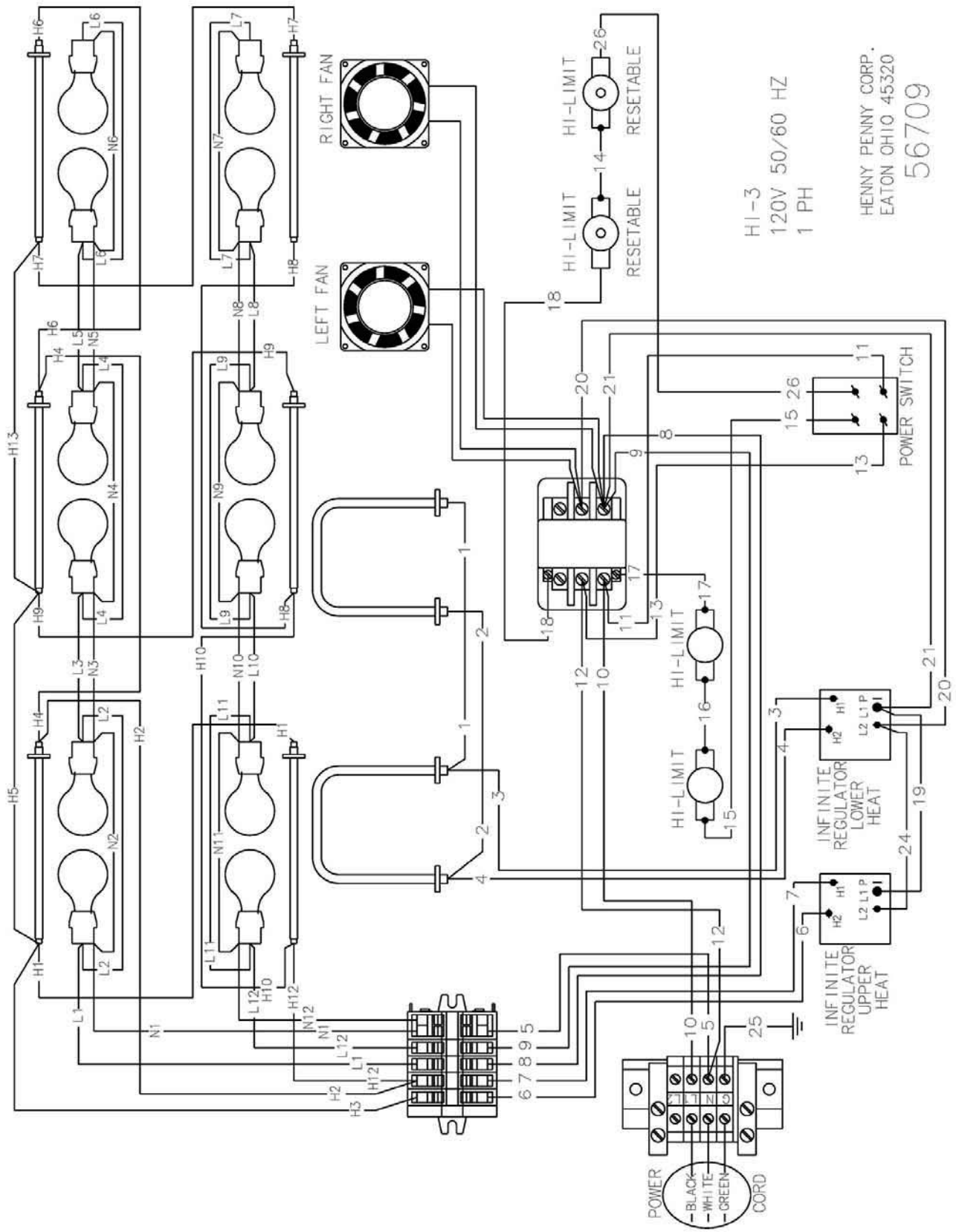

HI-3
120V 50/60 HZ
1 PH

HENNY PENNY CORP.
EATON OHIO 45320

56709

2-14. WIRING DIAGRAMS (Continued)

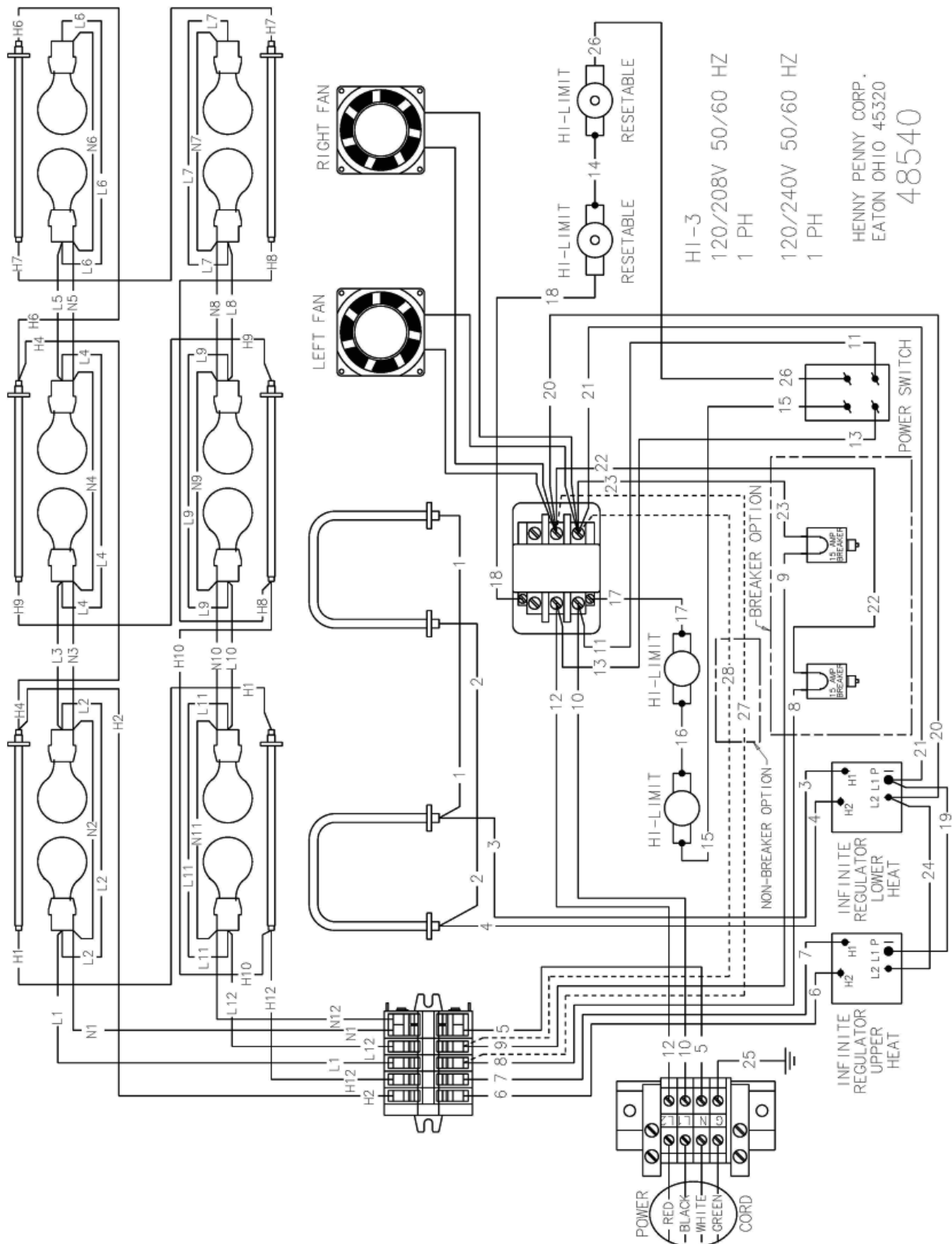

2-14. WIRING DIAGRAMS (Continued)

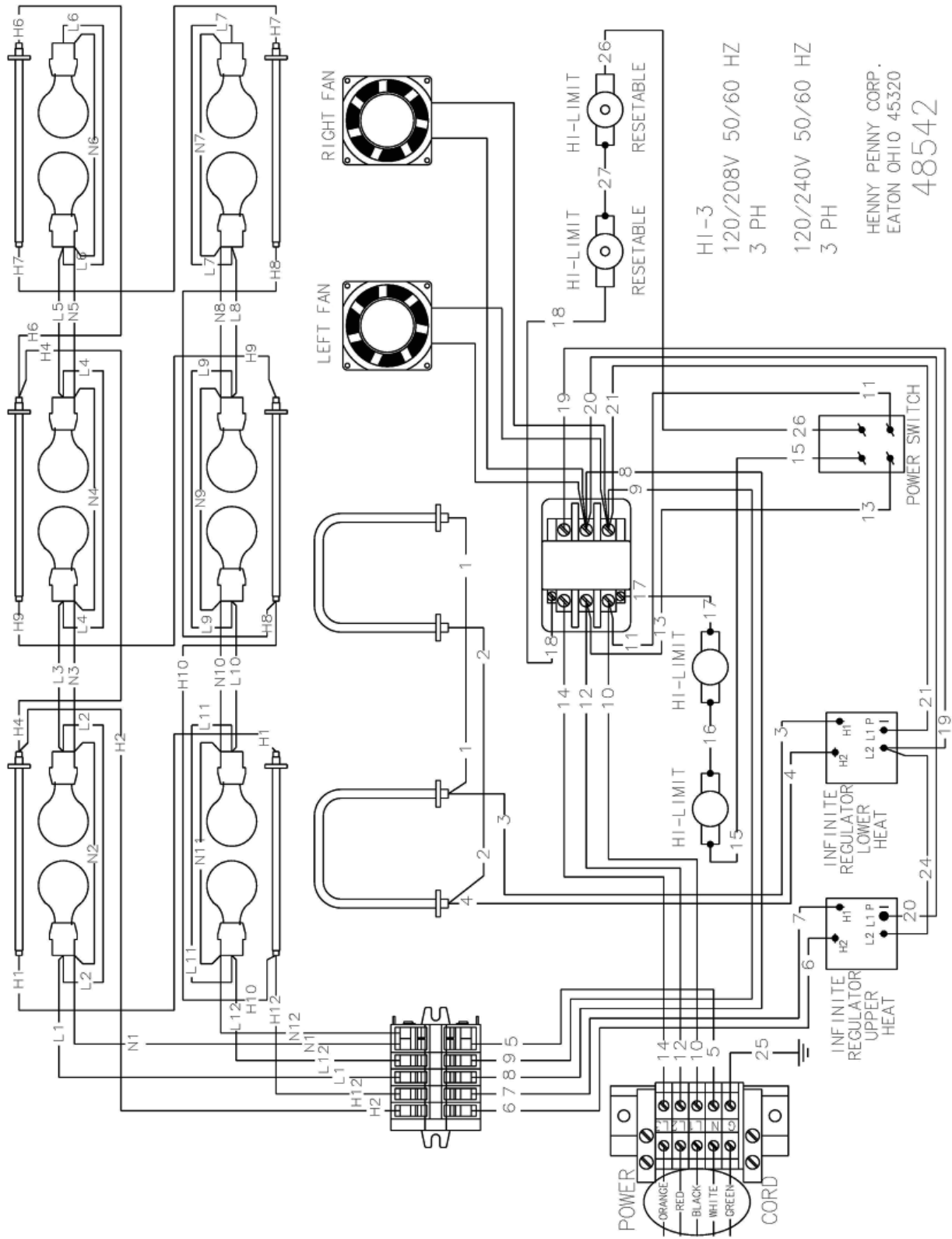

2-14. WIRING DIAGRAMS (Continued)

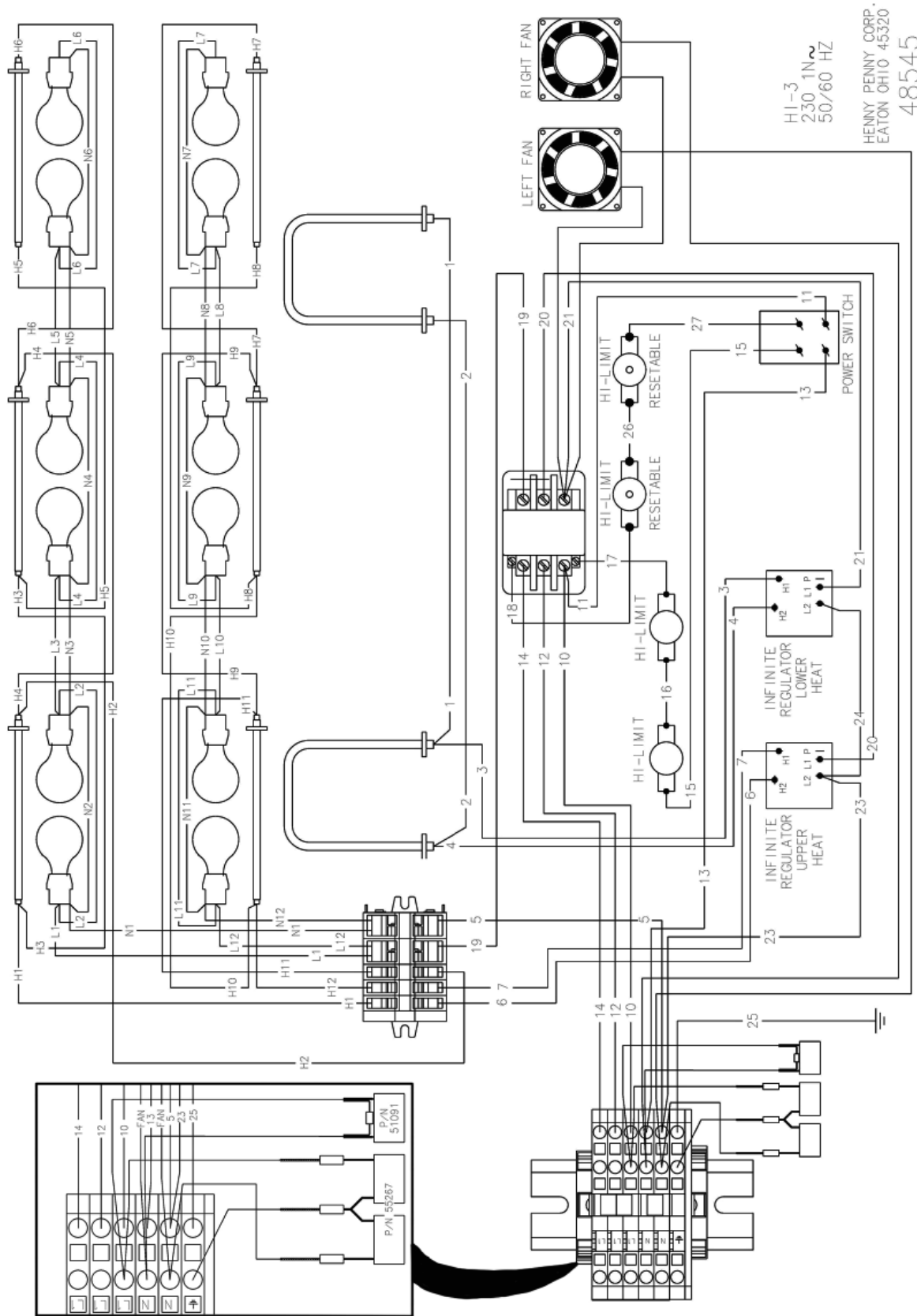

HI-3
230 1N~
50/60 HZ
HENNY PENNY CORP.
EATON OHIO 45320
48545

2-14. WIRING DIAGRAMS (Continued)

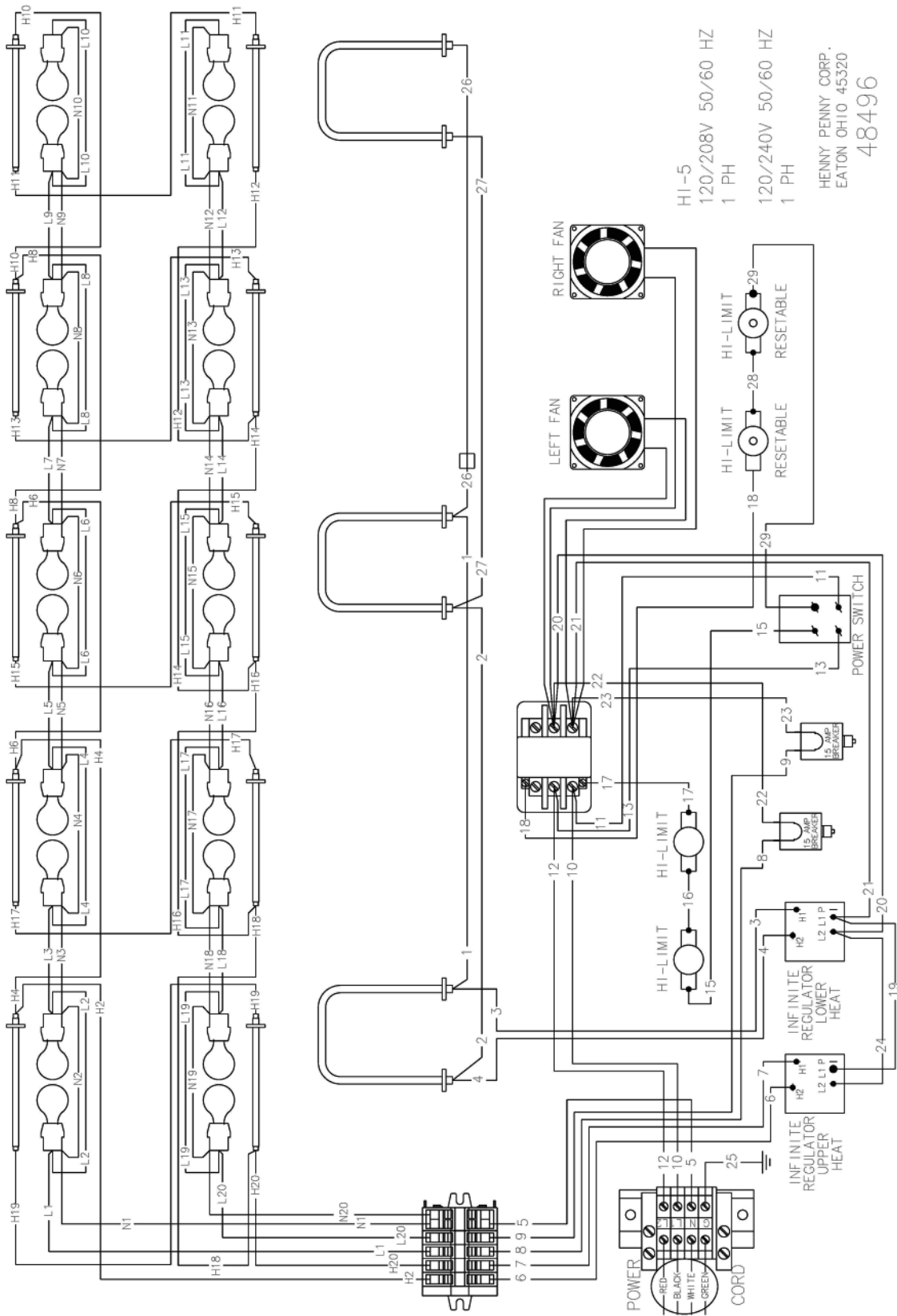

2-14. WIRING DIAGRAMS (Continued)

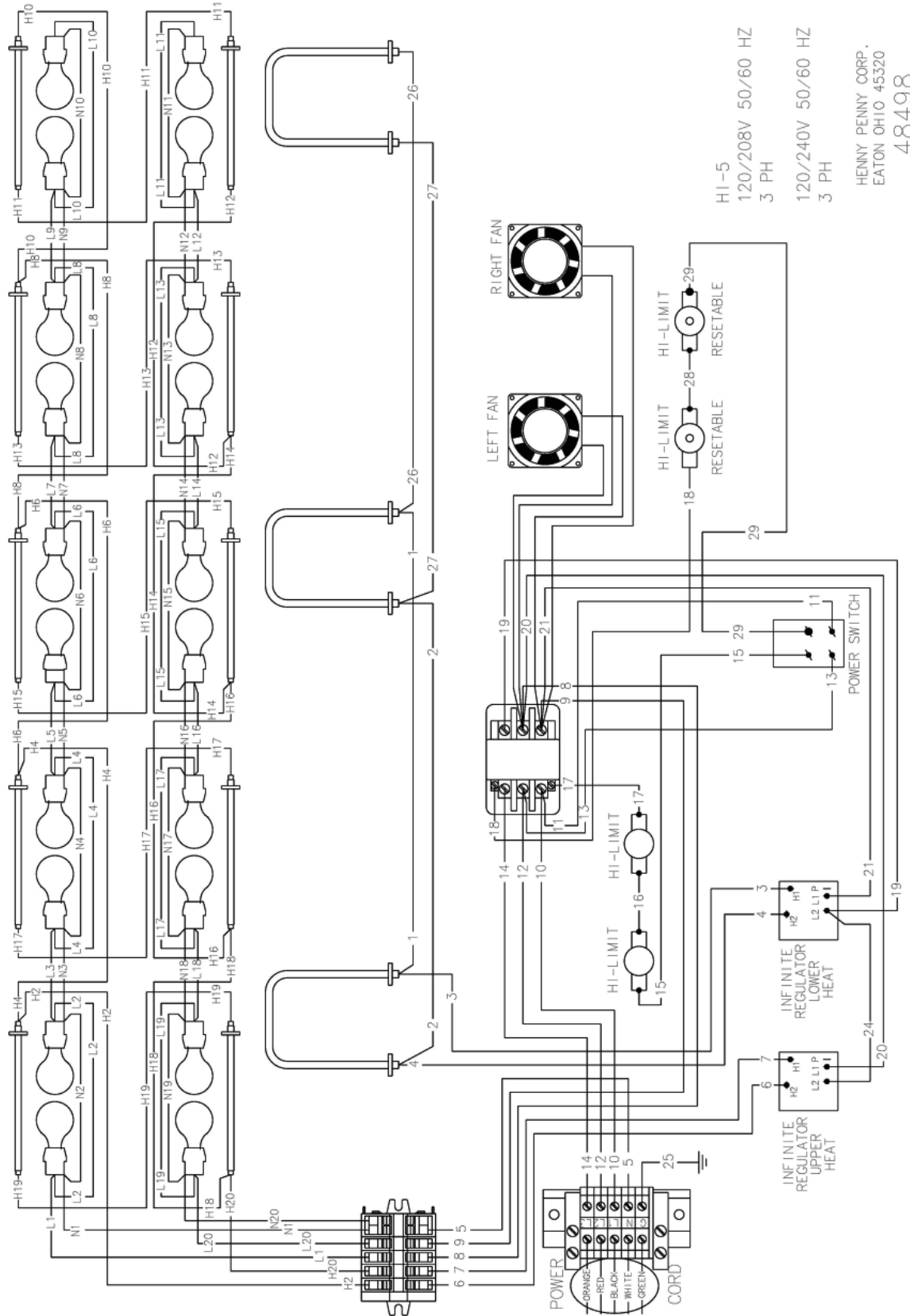

HI-5
120/208V 50/60 HZ
3 PH

120/240V 50/60 HZ
3 PH

HENNY PENNY CORP.
EATON OHIO 45320
48498

2-14. WIRING DIAGRAMS (Continued)

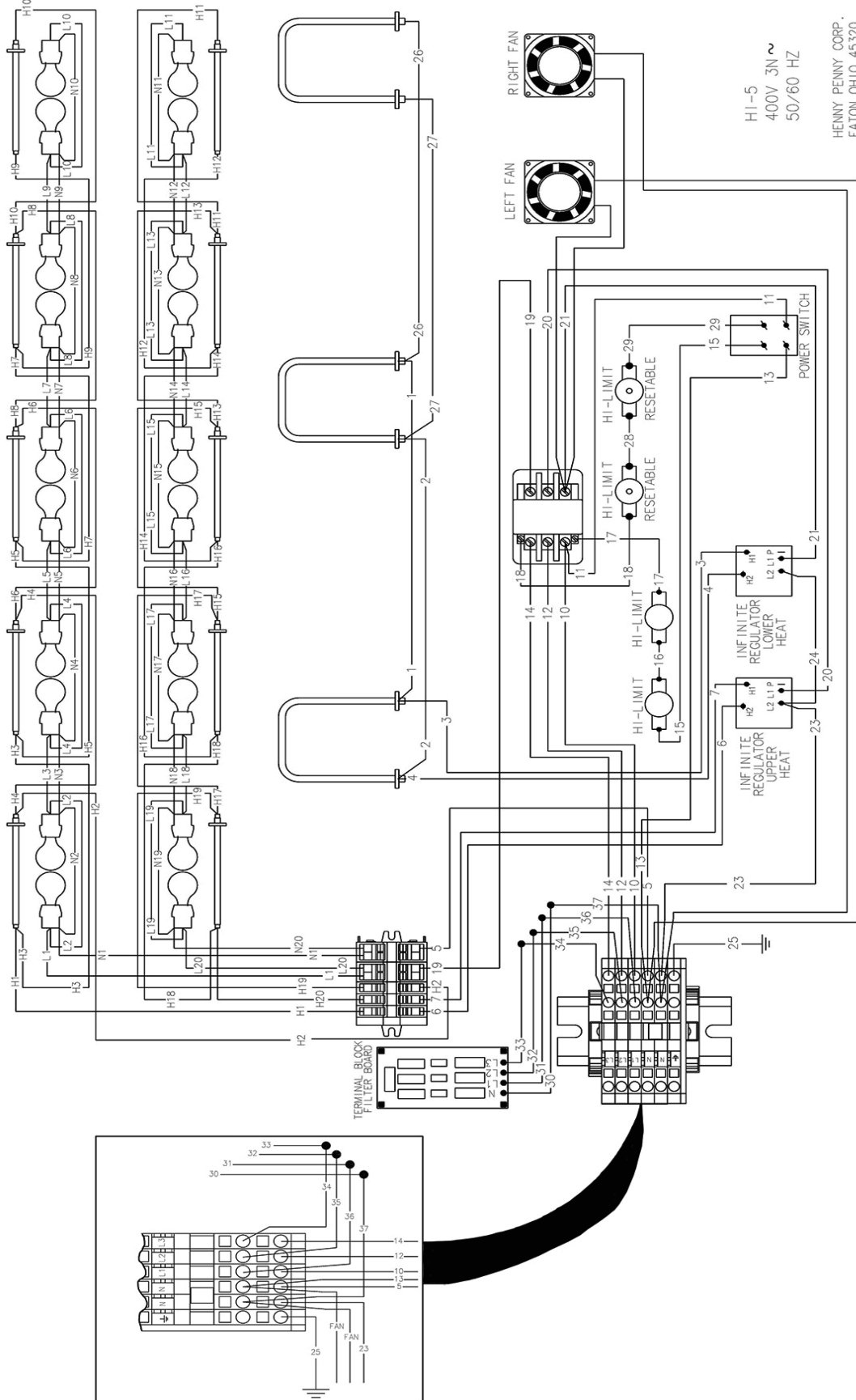

HI-5
400V 3N~
50/60 HZ

HENNY PENNY CORP.
EATON OHIO 45320
48500

LIMITED WARRANTY FOR HENNY PENNY EQUIPMENT

Subject to the following conditions, Henny Penny Corporation makes the following limited warranties to the original purchaser only for Henny Penny appliances and replacement parts:

NEW EQUIPMENT: Any part of a new appliance, except baskets, lamps, and fuses, which proves to be defective in material or workmanship within two (2) years from date of original installation, will be repaired or replaced without charge F.O.B. factory, Eaton, Ohio, or F.O.B. authorized distributor. Baskets will be repaired or replaced for ninety (90) days from date of original installation. Lamps and fuses are not covered under this Limited Warranty. To validate this warranty, the registration card for the appliance must be mailed to Henny Penny within ten (10) days after installation.

FILTER SYSTEM: Failure of any parts within a fryer filter system caused by the use of the non-OEM filters or other unapproved filters is not covered under this Limited Warranty.

REPLACEMENT PARTS: Any appliance replacement part, except lamps and fuses, which proves to be defective in material or workmanship within ninety (90) days from date of original installation will be repaired or replaced without charge F.O.B. factory, Eaton, Ohio, or F.O.B. authorized distributor.

The warranty for new equipment covers the repair or replacement of the defective part and includes labor charges and maximum mileage charges of 200 miles round trip for a period of one (1) year from the date of original installation.

The warranty for replacement parts covers only the repair or replacement of the defective part and does not include any labor charges for the removal and installation of any parts, travel, or other expenses incidental to the repair or replacement of a part.

EXTENDED FRYPOT WARRANTY: Henny Penny will replace any frypot that fails due to manufacturing or workmanship issues for a period of up to seven (7) years from date of manufacture. This warranty shall not cover any frypot that fails due to any misuse or abuse, such as heating of the frypot without shortening.

0 TO 3 YEARS: During this time, any frypot that fails due to manufacturing or workmanship issues will be replaced at no charge for parts, labor, or freight. Henny Penny will either install a new frypot at no cost or provide a new or reconditioned replacement fryer at no cost.

3 TO 7 YEARS: During this time, any frypot that fails due to manufacturing or workmanship issues will be replaced at no charge for the frypot only. Any freight charges and labor costs to install the new frypot as well as the cost of any other parts replaced, such as insulation, thermal sensors, high limits, fittings, and hardware, will be the responsibility of the owner.

Any claim must be presented to either Henny Penny or the distributor from whom the appliance was purchased. No allowance will be granted for repairs made by anyone else without Henny Penny's written consent. If damage occurs during shipping, notify the sender at once so that a claim may be filed.

THE ABOVE LIMITED WARRANTY SETS FORTH THE SOLE REMEDY AGAINST HENNY PENNY FOR ANY BREACH OF WARRANTY OR OTHER TERM. BUYER AGREES THAT NO OTHER REMEDY (INCLUDING CLAIMS FOR ANY INCIDENTAL OR CONSEQUENTIAL DAMAGES) SHALL BE AVAILABLE.

The above limited warranty does not apply (a) to damage resulting from accident, alteration, misuse, or abuse; (b) if the equipment's serial number is removed or defaced; or (c) for lamps and fuses. THE ABOVE LIMITED WARRANTY IS EXPRESSLY IN LIEU OF ALL OTHER WARRANTIES, EXPRESS OR IMPLIED, INCLUDING MERCHANTABILITY AND FITNESS, AND ALL OTHER WARRANTIES ARE EXCLUDED. HENNY PENNY NEITHER ASSUMES NOR AUTHORIZES ANY PERSON TO ASSUME FOR IT ANY OTHER OBLIGATION OR LIABILITY.

Revised 01/01/07

SECTION 3. PARTS INFORMATION

3-1. INTRODUCTION

This section lists the replaceable parts of the Henny Penny Island Warmer.

3-2. GENUINE PARTS

Use only genuine Henny Penny parts in your warmer. Using a part of lesser quality or substitute design may result in damage to the unit or personal injury.

3-3. WHEN ORDERING PARTS

Once the parts that you want to order have been found in the parts list, write down the following information:

(Sample)

Item Number 3
Part Number 39795
Description Lamp Holder

From the data plate, list the following information:

(Sample)

Product Number HMI105.0
Serial Number 0001
Voltage 120/208

3-4. PRICES

Your distributor has a price parts list and will be glad to inform you of the cost of your parts order.

3-5. DELIVERY

Commonly replaced items are stocked by your distributor and will be sent out when your order is received. Other parts will be ordered, by your distributor, from Henny Penny Corp. Normally, these will be sent to your distributor within three working days.

3-6. WARRANTY

All replacement parts (except lamps and fuses) are warranted for 90 days against manufacturing defects and workmanship. If damage occurs during shipping, notify the carrier at once so a claim may be properly filed. Refer to warranty in the front of this manual for other rights and limitations.

3-7. RECOMMENDED SPARE PARTS FOR DISTRIBUTORS

Recommended replacement parts, stocked by your distributor, are indicated with √ in the parts lists. Please use care when ordering recommended parts, because all voltages and variations are marked. Distributors should order parts based upon common voltages and equipment sold in their territory.

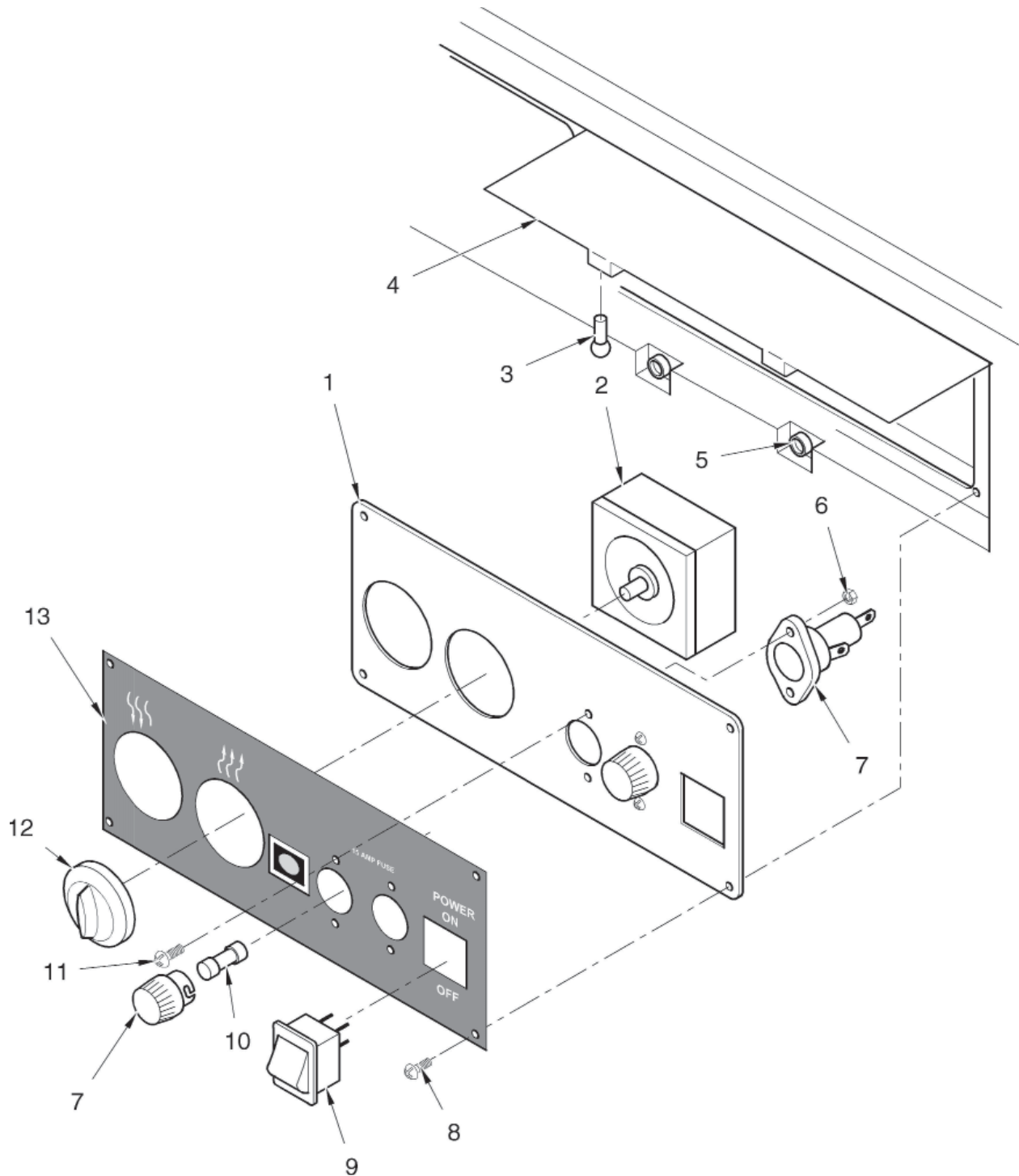

Figure 3-1. Control Panel Assy.

FIG. & ITEM NO.	PART NO.	DESCRIPTION	HMI-103	HMI-105
3-1		CONTROL PANEL ASSY.		
1	45710	CONTROL PANEL	1	1
√ 2	22317	INFINITE REGULATOR	2	2
3	MS01-381	BLACK NYLON CLIP	2	2
4	45717	CONTROL ACCESS PANEL	1	1
5	MS01-382	BLACK NYLON RECEIVER	2	2
6	NS02-005	NUT	4	4
√ 7	EF02-006	FUSE HOLDER	2	2
8	SC04-003	SCREW	4	4
√ 9	72277	POWER SWITCH	1	1
√ 10	EF02-007	FUSE	2	2
11	SC01-113	SCREW	4	4
12	22046	INFINITE SWITCH KNOB	2	2
13	45835	DECAL - HMI-103	1	-
13	45809	DECAL - HMI-105	-	1
13	48547	DECAL - HMI-103 C.E.	1	-
13	48521	DECAL - HMI-105 C.E.	-	1

√ recommended parts

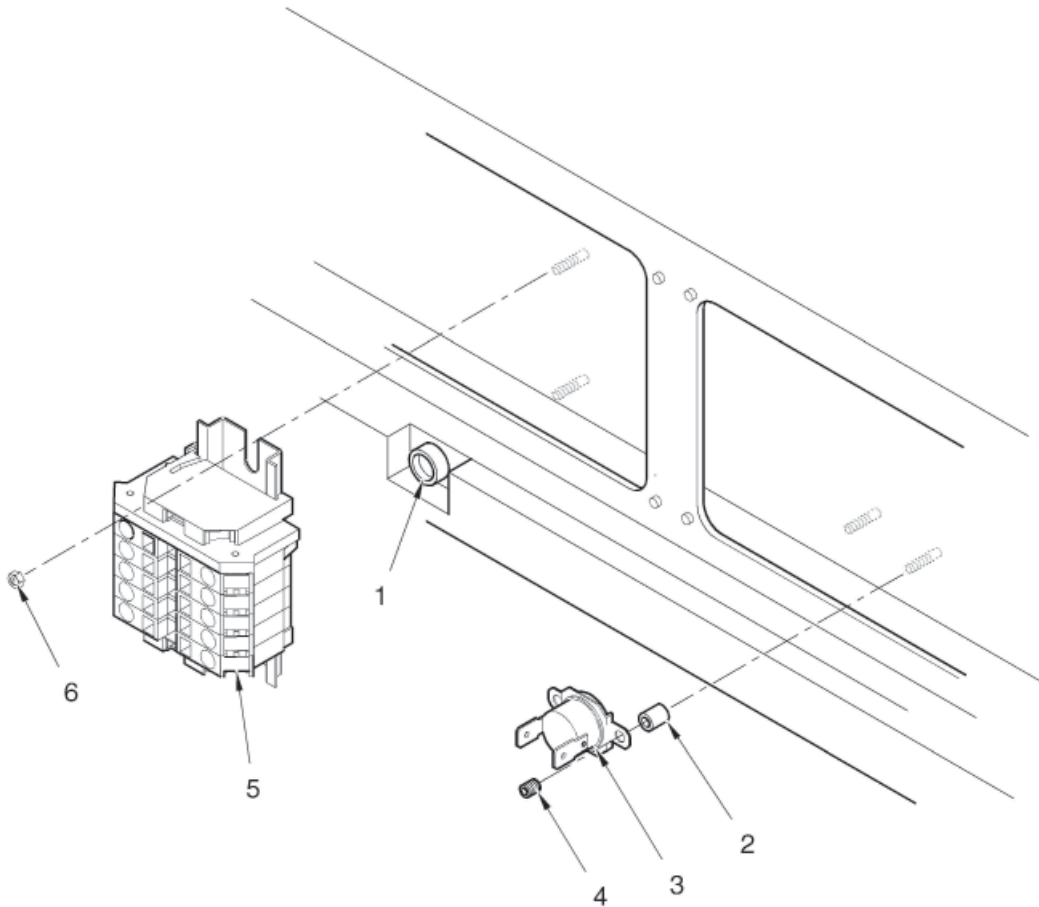

Figure 3-2. Terminal Block

FIG. & ITEM NO.	PART NO.	DESCRIPTION	HMI-103	HMI-105
1	MS01-382	NYLON RECEPTACLE	2	2
2	ME50-013	SPACER	4	4
√ 3	48122	HIGH LIMIT	2	2
4	ME50-023	STANDOFF	4	4
5	34924	TERMINAL BLOCK ASSY. (3 PHASE)	1	1
5	34925	TERMINAL BLOCK ASSY. (1 PHASE)	1	1
6	NS02-006	NUT	2	2

√ recommended parts

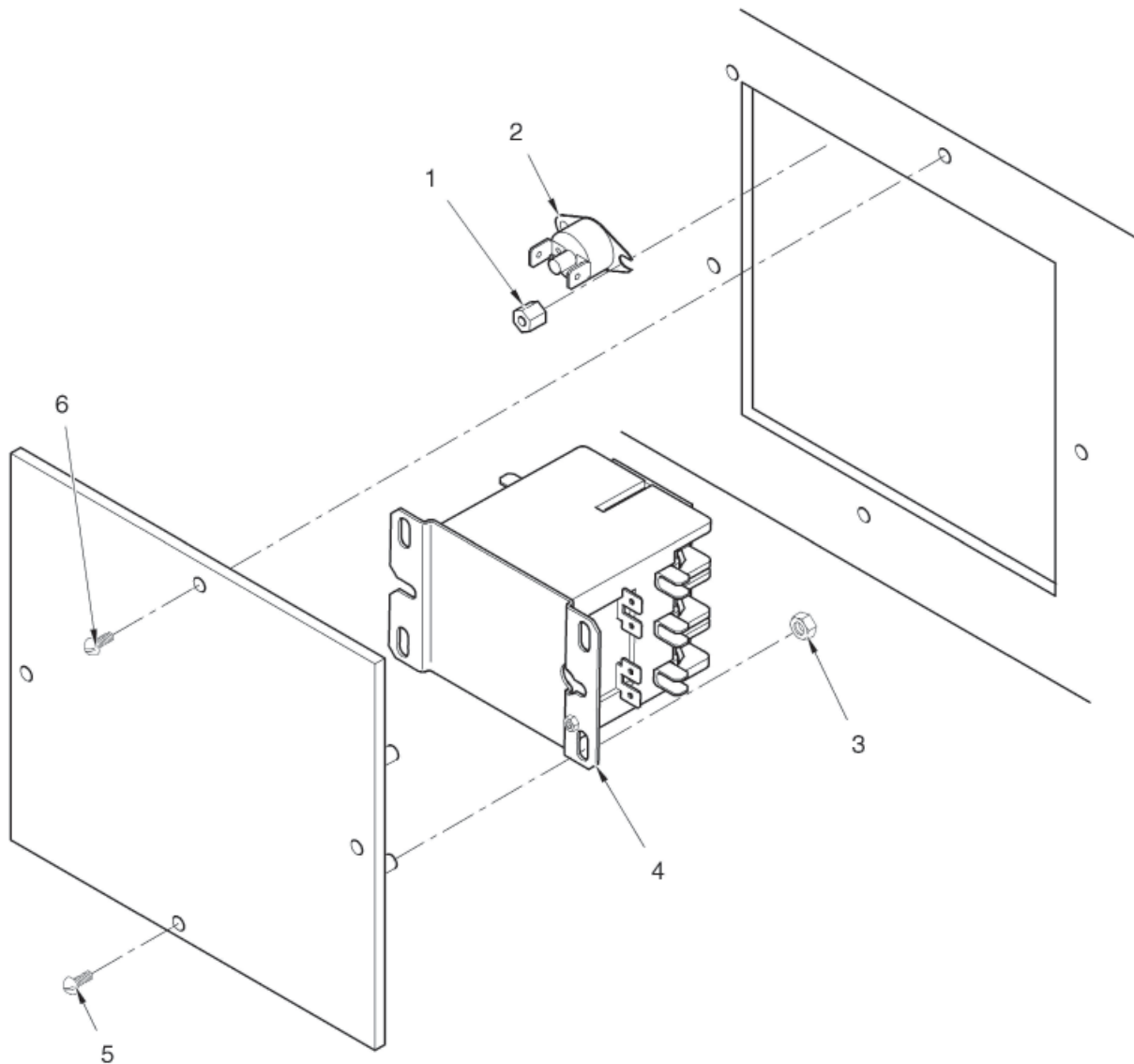

Figure 3-3. Contactor

FIG. & ITEM NO.	PART NO.	DESCRIPTION	HMI-103	HMI-105
1	ME50-023	STANDOFF	4	4
√ 2	49547	HI LIMIT - MANUAL RESET	2	2
3	NS02-006	NUT	4	4
√ 4	19405	CONTACTOR - 208/240 V	1	1
√ 4	56616	CONTACTOR - 120 V	1	1
5	SC04-003	SCREW	3	3
6	SC01-205	SCREW	1	1
7*	55267	EMC FILTER ASSY - CE	1	1

√ recommended parts

* not shown

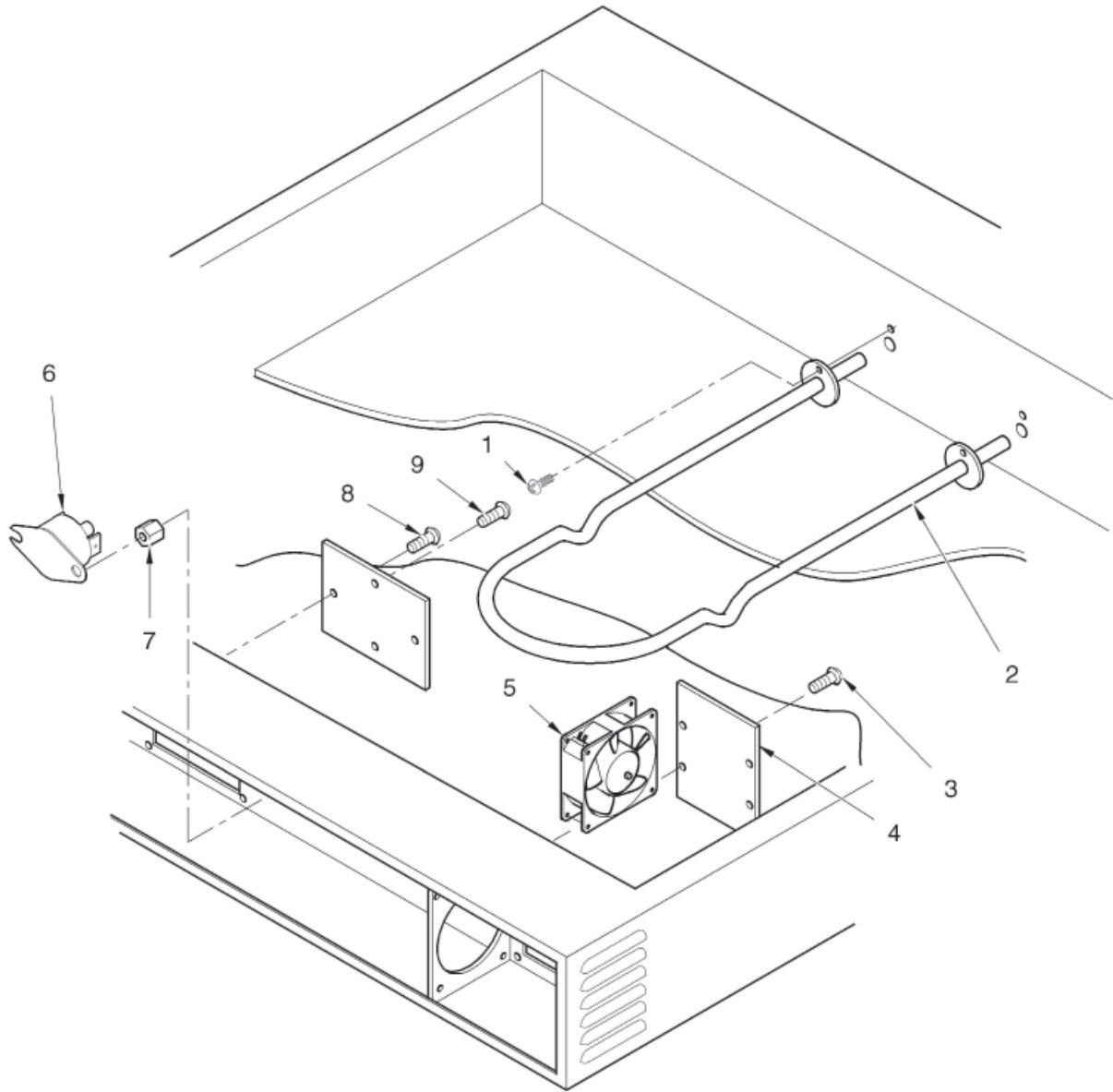

Figure 3-4. Lower Heat

FIG. & ITEM NO.	PART NO.	DESCRIPTION	HMI-103	HMI-105
3-4		LOWER HEAT		
1	SC02-041	SCREW	4	6
√ 2	56617	HEATER - LOWER - 120V - CE	2	2
√ 2	44976	HEATER - LOWER - 208V	2	3
√ 2	37059	HEATER - LOWER - 240V	2	3
√ 2	54025	HEATER - LOWER - 230V - CE - 400V	2	3
3	SC04-003	SCREW (FAN BOX COVER)	8	8
4	49537	FAN ACCESS PANEL	2	2
√ 5	37398	COOLING FAN - 220/230V	2	2
√ 5	56615	COOLING FAN - 110-120V	2	2
√ 6	49547	HIGH LIMIT - MANUAL RESET	2	2
7	ME50-023	STANDOFF	4	4
8	SC04-003	SCREW (COVER PLATE)	3	3
9	SC01-205	SCREW	1	1
10*	68513	COVER-WELL HMI 4" DEEP (5 WELL)	-	5
10*	68514	COVER-WELL HMI 4" DEEP (3 WELL)	3	-

√ recommended parts / * not shown

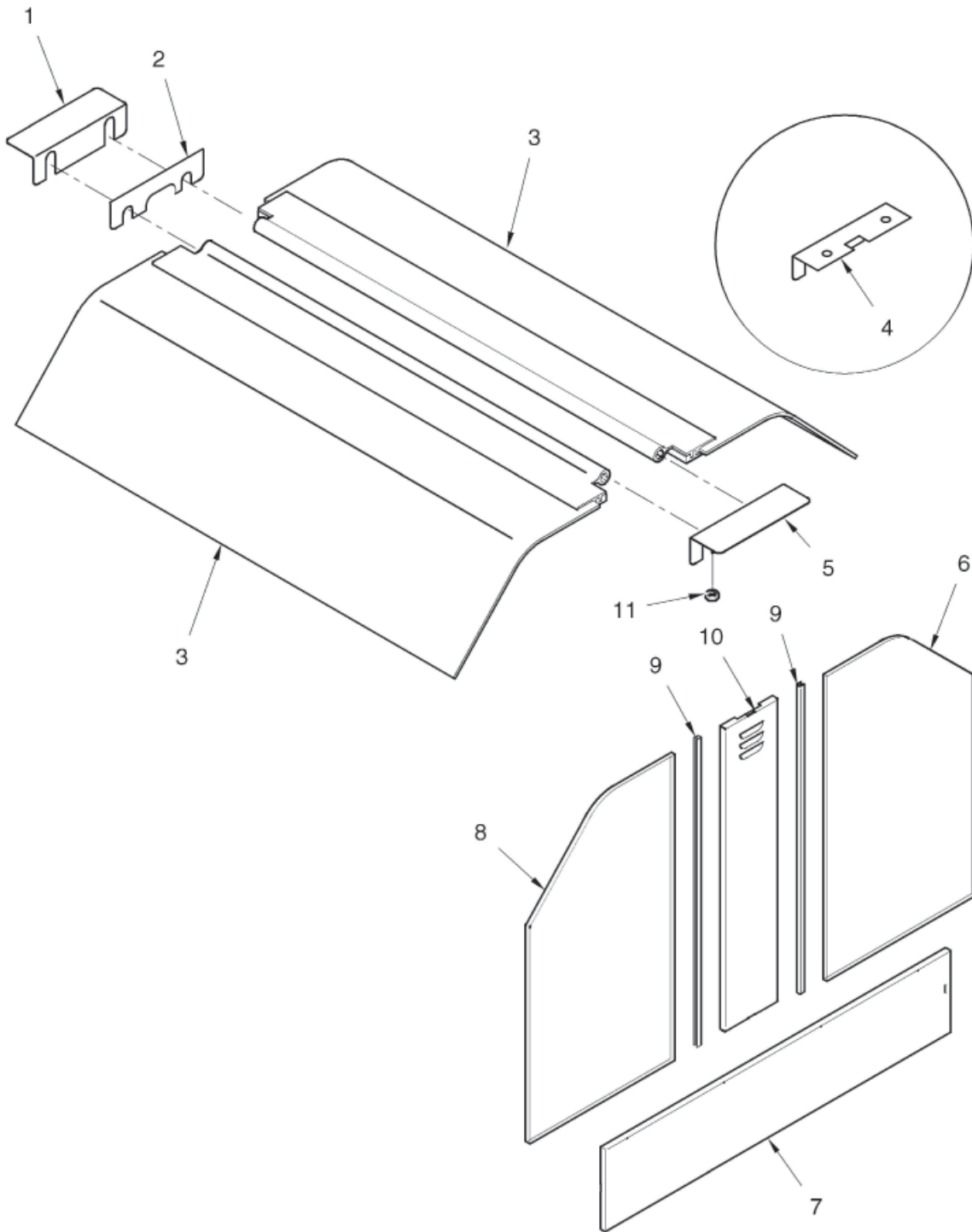

Figure 3-5. Glass Panels

FIG. & ITEM NO.	PART NO.	DESCRIPTION	HMI-103	HMI-105
3-5		GLASS PANELS (VIEWED FROM CUSTOMER SIDE)		
1	48626	HINGE BLOCK COVER STUD ASSEMBLY	1	1
2	45745	HINGE BLOCK	2	2
3	79424	CANOPY GLASS ASSY.	2	--
3	79425	CANOPY GLASS ASSY.	--	2
4	49567	UPRIGHT COVER TOP, CORD	1	1
5	48626	HINGE BLOCK COVER STUD ASSEMBLY	1	1
6	45677	END GLASS-CLEAR (FRONT RT/LEFT REAR)	2	2
6	48508	END GLASS-MIRROR (FRONT RT/LEFT REAR)	2	2
6*	45727	END PLATE	4	4
6*	SC04-003	SCREW	4	4
7	45699	BOTTOM ACCESS PANEL	2	2
8	48568	END GLASS-CLEAR (FRONT LT/RIGHT REAR)	2	2
8	48507	END GLASS-MIRROR(FRONT LT/RIGHT REAR)	2	2
9	48522	END GLASS SEAL	4	4
10	45697	UPRIGHT ACCESS PANEL	2	2
11	NS02-006	NUT	4	4
12*	49593	POWER CORD ASSY. 30A-1PH TOP EXIT	1	1
12*	37849	POWER CORD ASSY. 30A	1	1
12*	37123	POWER CORD ASSY. 20A-1PH-120V	1	--
12*	69598	POWER CORD ASSY. 20A-1PH-120/208V BOT EXIT	1	--
12*	69599	POWER CORD ASSY. 20A-1PH-120/208V TOP EXIT	1	--
12*	49594	POWER CORD ASSY. 20A-3PH BOT. EXIT	1	1
12*	49596	POWER CORD ASSY. 20A-3PH TOP EXIT	1	1
13*	05907	PEDESTAL BASE MOUNTING KIT	--	1
13*	05906	PEDESTAL BASE MOUNTING KIT	1	--
14*	53185	BREAD SHELF ASSEMBLY - SAFEWAY	1	1
15*	48561	INSULATION, BOTTOM	1	--
15*	48523	INSULATION, BOTTOM	--	1
16*	48564	INSULATION, CUSTOMER SIDE	1	--
16*	48524	INSULATION, CUSTOMER SIDE	--	1
17*	48565	INSULATION, CONTROL SIDE	1	--
17*	48525	INSULATION, CONTROL SIDE	--	1

*not shown

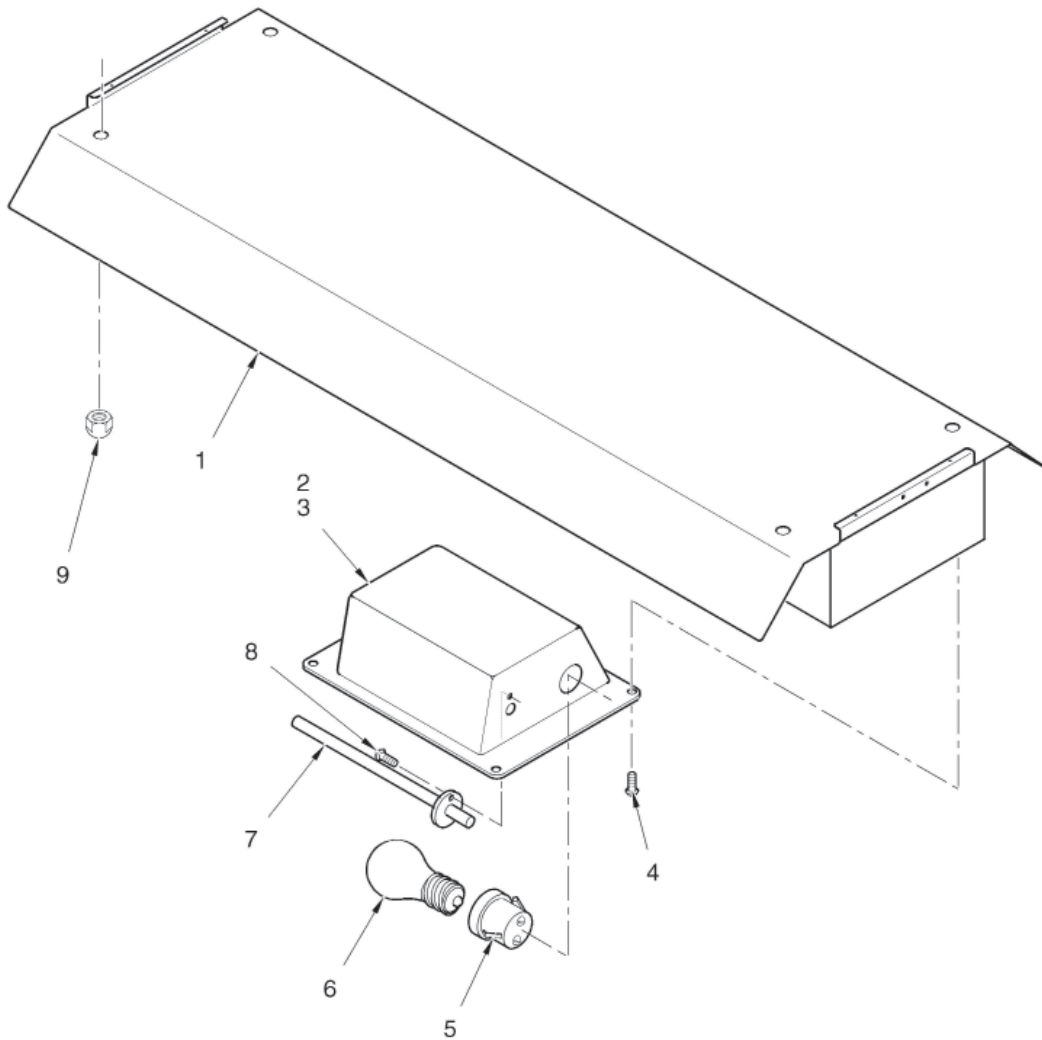

Figure 3-6. Upper Heat

FIG. & ITEM NO.	PART NO.	DESCRIPTION	HMI-103	HMI-105
1	45683	CANOPY SHIELD	-	1
1	45761	CANOPY SHIELD	1	-
2	46007	LIGHT REFLECTOR	6	10
3	46009	HEAT REFLECTOR	6	10
4	SC04-003	SCREW	4	4
√ 5	39795	LAMP HOLDER	12	20
√ 5	54041	LAMP HOLDER - CE & 400V INT'L	12	20
√ 6	BL01-018	BULB-90W-Halogen -120V/208V/240V	12	20
√ 6	BL01-015	BULB-60W-Teflon Coated-230V/50Hz/1Ph or 400V/50Hz/3Ph	12	20
√ 7	48650	HEATER-UPPER-RADIANT-104V-180W (208)	6	10
√ 7	48651	HEATER-UPPER-RADIANT-115V-180W (240)	6	10
√ 7	56618	HEATER-UPPER-RADIANT-120V-115W (120)	6	10
8	SC04-003	SCREW	6	10
9	NS03-016	ACORN NUT	4	4
10*	14666	KIT-HMI 10X LMAP GUARD	12	20

√ recommended parts / * not shown