



OPERATOR'S M A N U A L

HEATED MERCHANDISERS

MODEL

HMR-103

HMR-104

HMR-105

HMR-106

HMR-107



HENNY PENNY
Engineered to Last

REGISTER WARRANTY ONLINE AT WWW.HENNYPENNY.COM

TABLE OF CONTENTS

Section	Page
Section 1. INTRODUCTION	1-1
1-1. Heated Merchandiser	1-1
1-2. Features	1-1
1-3. Assistance	1-1
1-4. Safety	1-2
Section 2. INSTALLATION	2-1
2-1. Introduction	2-1
2-2. Unpacking	2-1
2-3. Electrical Connection	2-2
2-4. Electrical Data Table	2-3
2-5. Cabinet Dimensions	2-5
2-6. Center Glass Installation	2-6
2-7. Side Glass Installation	2-8
Section 3. OPERATION	3-1
3-1. Introduction	3-1
3-2. Start-Up	3-1
3-3. Operation with Product	3-2
3-4. Shut Down and Clean Up	3-3
3-5. Light Bulb Replacement	3-5
3-6. Special Programming	3-6
Section 4. TROUBLESHOOTING	4-1
4-1. Troubleshooting Guide	4-1
4-2. Error Codes and Warnings	4-1
GLOSSARY	G-1

Distributors List - Domestic and International

SECTION 1. INTRODUCTION

1-1. HEATED MERCHANTISER

The Henny Penny Heated Merchandiser is a basic unit of food processing equipment used to display the food product and maintain the temperature of hot foods in a commercial food service operation. Using a combination of precise heat, humidity and slowly circulating air, Henny Penny's even heat process creates the ideal environment to maintain the taste and quality of freshly cooked foods for hours.



NOTICE

As of August 16, 2005, the Waste Electrical and Electronic Equipment directive went into effect for the European Union. Our products have been evaluated to the WEEE directive. We have also reviewed our products to determine if they comply with the Restriction of Hazardous Substances directive (RoHS) and have redesigned our products as needed in order to comply. To continue compliance with these directives, this unit must not be disposed as unsorted municipal waste. For proper disposal, please contact your nearest Henny Penny distributor.

1-2. FEATURES

- Unique THERMA-VEC® even heat process recirculates heated air, keeping temperature precise and stable throughout the case
- Contemporary curved glass cases present 100% product visibility
- Individually controlled radiant heaters over each well
- Ability to operate unit for up to an hour with the rear doors removed while maintaining food temperature
- Humidity controlled with heated water pan
- Touch pad electronic controls and LED readouts
- Halogen lighting for attractive food presentation
- Fold-down cutting board
- Low water indication
- Custom full/self serve units, in 2-well increments
- Separate controls above each well

1-3. ASSISTANCE

Should you require outside assistance, call your local independent distributor in your area, call Henny Penny at 1-800-417-8405 or 1-937-456-8405, or go to Henny Penny online at www.hennypenny.com.

1-4. SAFETY

The only way to ensure safe operation of the Henny Penny Heated Merchandisers is to fully understand the proper installation, operation, and maintenance procedures. The instructions in this manual have been prepared to aid you in learning the proper procedures. Where information is of particular importance or is safety related, the words, NOTICE, CAUTION, or WARNING are used. Their usage is described below.



SAFETY ALERT SYMBOL is used with DANGER, WARNING, or CAUTION which indicates a personal injury type hazard.



NOTICE is used to highlight especially important information.



CAUTION used without the safety alert symbol indicates a potentially hazardous situation which, if not avoided, may result in property damage.



CAUTION used with the safety alert symbol indicates a potentially hazardous situation which, if not avoided, may result in minor or moderate injury.



WARNING indicates a potentially hazardous situation which, if not avoided, could result in death or serious injury.

SECTION 2. INSTALLATION

2-1. INTRODUCTION

This section provides the installation instructions for the Henny Penny Heated Merchandiser.

NOTICE

Installation of this unit should be performed only by a qualified service technician.



Do not puncture the heated merchandiser with any objects such as drills or screws as component damage or electrical shock could result.

2-2. UNPACKING

The Henny Penny Heated Merchandiser is tested, inspected and expertly packed to ensure arrival at its destination in the best possible condition. The unit has been bolted to wooden skid. All items have been packed and taped inside of the unit. The unit is then packed inside a triple wall corrugated carton with sufficient padding to withstand normal shipping treatment.

NOTICE

Any shipping damage should be noted in the presence of the delivery agent and signed prior to his or her departure.

To remove the heated merchandiser from the carton, you should:

1. Carefully cut banding straps.
2. Open flaps of carton and remove packing.
3. Lift carton from unit.
4. Remove four bolts mounting the merchandiser to the skid.
5. If installing the unit on a merchandiser base, use existing bolts to mount unit.
6. Unpack doors, cutting board, and pan supports, and install.
7. The heated merchandiser is now ready for location and setup.

2-3. ELECTRICAL CONNECTION

The heated merchandiser is available from the factory, wired for 120/208-240 volts, single or three phase, (includes neutral), 220-240 volts, or 380-415 volts. Refer to the table at left, and bottom, for proper power connection.

NEMA NUMBERS:			
Model	208/240-1 ph	208-3 ph	240-3 ph
107	14-50P	L21-30P	Hardwire
106	14-50P	L21-30P	Hardwire
105	14-50P	L21-30P	Hardwire
104	L14-30P	L21-20P	Hardwire
103	L14-30P	L21-20P	Hardwire

NOTICE

International units are **not** supplied with cord and plug, and must be provided upon installation. If two CE units are placed side-by-side, a grounding wire needs to be placed between the equipotential bonding lugs, located under the cutting board brackets, of both units.



This unit must be adequately and safely grounded. Refer to local electrical codes for correct grounding procedures. If heated merchandiser is not adequately grounded, electrical shock could result.

(FOR EQUIPMENT WITH CE MARK ONLY!)

To prevent electric shock hazard this appliance must be bonded to other appliances or touchable metal surfaces in close proximity to this appliance with an equipotential bonding conductor. This appliance is equipped with an equipotential lug for this purpose. The equipotential lug is marked with the following symbol



A separate disconnect switch with proper capacity fuses or breakers must be installed at a convenient location between the unit and the power source.

2-4. ELECTRICAL DATA TABLE

MODEL	COMBI-NATION	VOLTS	KW	AMPS		MODEL	COMBI-NATION	VOLTS	KW	AMPS					
				1 PHASE	3 PHASE					1 PHASE	3 PHASE				
HMR-107	7S	120/208	5.0	24	18	HMR-107	3F/2S/2F*	120/208	6.0	29	19				
			6.7	32	22				7.8	37	23				
		120/240	5.0	16	16			120/240	6.0	25	17				
			7.0	29	20				8.1	34	21				
		220-240	5.4	22	N/A			220-240	6.4	27	N/A				
			7.5	31	N/A				8.5	36	N/A				
		380-415	5.4	N/A	11			380-415	6.4	N/A	11				
			7.5	N/A	11				8.5	N/A	13				
		HMR-107	7F	120/208	6.0			29	19	HMR-107	2S/3F/2S	120/208	5.5	27	19
					7.8			37	23				7.3	35	22
120/240	6.0			25	17	120/240	5.5	23	16						
	8.1			34	21		7.6	32	20						
220-240	6.4			27	N/A	220-240	6.0	25	N/A						
	8.5			36	N/A		8.0	33	N/A						
380-415	6.4			N/A	11	380-415	6.0	N/A	11						
	8.5			N/A	13		8.0	N/A	12						
HMR-107	5S/2F*			120/208	5.5	26	18	HMR-107	2F/3S/2F			120/208	5.9	29	19
					7.2	35	22						7.7	37	22
		120/240	5.5	23	16	120/240	5.9			25	16				
			7.5	31	20		8.0			33	20				
		220-240	5.9	24	N/A	220-240	6.4			27	N/A				
			7.9	33	N/A		8.4			35	N/A				
		380-415	5.9	N/A	11	380-415	6.4			N/A	11				
			7.9	N/A	12		8.4			N/A	12				
		HMR-107	5F/2S*	120/208	5.5	27	19			HMR-106	6S	120/208	4.0	19	13
					7.3	35	22						5.5	26	16
120/240	5.5			23	16	120/240	4.0	17	12						
	7.3			30	20		5.7	24	15						
220-240	6.0			25	N/A	220-240	4.3	18	N/A						
	8.0			33	N/A		6.1	25	N/A						
380-415	6.0			N/A	11	380-415	4.3	N/A	8						
	8.0			N/A	12		6.1	N/A	9						
HMR-107	4S/3F*			120/208	5.5	27	19	HMR-106	6F			120/208	5.0	24	15
					7.3	35	22						6.5	31	20
		120/240	5.5	23	16	120/240	5.0			21	13				
			7.6	32	21		6.8			28	18				
		220-240	6.0	25	N/A	220-240	5.4			22	N/A				
			8.0	33	N/A		7.2			30	N/A				
		380-415	6.0	N/A	11	380-415	5.4			N/A	8				
			8.0	N/A	12		7.2			N/A	12				
		HMR-107	4F/3S*	120/208	5.5	27	19			HMR-106	4S/2F*	120/208	4.5	21	14
					7.3	35	22						6.0	29	17
120/240	5.5			23	16	120/240	4.5	19	12						
	7.6			32	20		6.2	26	16						
220-240	6.0			25	N/A	220-240	4.8	20	N/A						
	8.0			33	N/A		6.6	27	N/A						
380-415	6.0			N/A	11	380-415	4.8	N/A	8						
	8.0			N/A	12		6.6	N/A	10						
HMR-107	3S/2F/2S*			120/208	5.5	27	18	HMR-106	4F/2S*			120/208	4.5	22	14
					7.2	35	22						6.0	29	17
		120/240	5.5	23	16	120/240	4.5			19	12				
			7.5	31	20		6.3			26	16				
		220-240	5.9	24	N/A	220-240	4.9			20	N/A				
			7.9	33	N/A		6.7			28	N/A				
		380-415	5.9	N/A	11	380-415	4.9			N/A	8				
			7.9	N/A	12		6.7			N/A	10				

*Well modules can be arranged in opposite order

2-4. ELECTRICAL DATA TABLE (Continued)

MODEL	COMBI-NATION	VOLTS	KW	AMPS		MODEL	COMBI-NATION	VOLTS	KW	AMPS	
				1 PHASE	3 PHASE					1 PHASE	3 PHASE
HMR-106 (Cont.)	3S/2F*	120/208	5.2	25	17	HMR-105 (Cont.)	3F/2S*	120/208	4.2	20	14
			6.7	32	20				5.5	26	17
		120/240	5.2	22	15			120/240	4.2	18	12
			7.0	29	18				5.7	24	15
		220-240	5.5	23	N/A			220-240	4.5	19	N/A
			7.3	31	N/A				6.0	25	N/A
380-415	5.5	N/A	11	380-415	4.5	N/A	8				
	7.3	N/A	11		6.0	N/A	9				
HMR-106	2S/2F/2S	120/208	4.5	21	14	HMR-104	4S	120/208	2.6	13	9
			6.0	29	17				3.6	17	11
		120/240	4.5	19	12			120/240	2.6	11	8
			6.2	26	16				3.8	16	10
		220-240	4.8	20	N/A			220-240	2.8	12	N/A
			6.6	27	N/A				4.0	17	N/A
380-415	4.8	N/A	8	380-415	2.8	N/A	5				
	6.6	N/A	10		4.0	N/A	6				
HMR-106	2F/2S/2F	120/208	4.9	24	14	HMR-104	4F	120/208	3.2	15	9
			6.4	31	19				4.2	20	12
		120/240	4.9	21	13			120/240	3.2	13	8
			6.7	28	18				4.4	18	12
		220-240	5.3	22	N/A			220-240	3.4	14	N/A
			7.1	30	N/A				4.6	19	N/A
380-415	5.3	N/A	8	380-415	3.4	N/A	5				
	7.1	N/A	12		4.6	N/A	7				
HMR-105	5S	120/208	3.6	18	13	HMR-104	2S/2F*	120/208	3.1	15	9
			4.9	24	16				4.1	20	12
		120/240	3.6	15	12			120/240	3.1	13	8
			5.1	21	15				4.3	18	11
		220-240	3.9	16	N/A			220-240	3.3	14	N/A
			5.4	23	N/A				4.5	19	N/A
380-415	3.9	N/A	8	380-415	3.3	N/A	5				
	5.4	N/A	8		4.5	N/A	7				
HMR-105	5F	120/208	4.2	20	14	HMR-103	3S	120/208	2.3	11	9
			5.5	26	17				3.0	15	11
		120/240	4.2	18	12			120/240	2.3	10	8
			5.7	24	15				3.2	13	10
		220-240	4.5	19	N/A			220-240	2.4	10	N/A
			6.0	25	N/A				3.4	14	N/A
380-415	4.5	N/A	8	230	2.4	11	N/A				
	6.0	N/A	9		380-415	2.4	N/A	5			
HMR-105	3S/2F*	120/208	4.1	20	14	HMR-103	3F	120/208	2.8	14	9
			5.4	26	17				3.6	17	11
		120/240	4.3	18	13			120/240	2.8	12	8
			5.6	23	15				3.7	16	10
		220-240	4.4	18	N/A			220-240	3.0	12	N/A
			5.9	25	N/A				3.9	16	N/A
380-415	4.4	N/A	8	230	3.0	13	N/A				
	5.9	N/A	9		380-415	3.0	N/A	5			
								3.9	N/A	6	

*Well modules can be arranged in opposite order

2-5. CABINET DIMENSIONS

Curved Profile

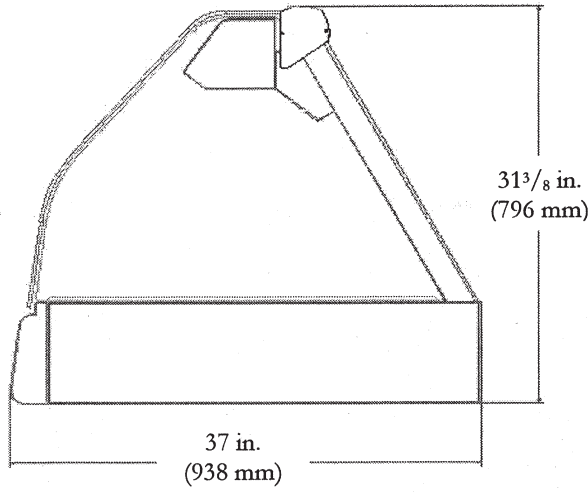

Flat Profile

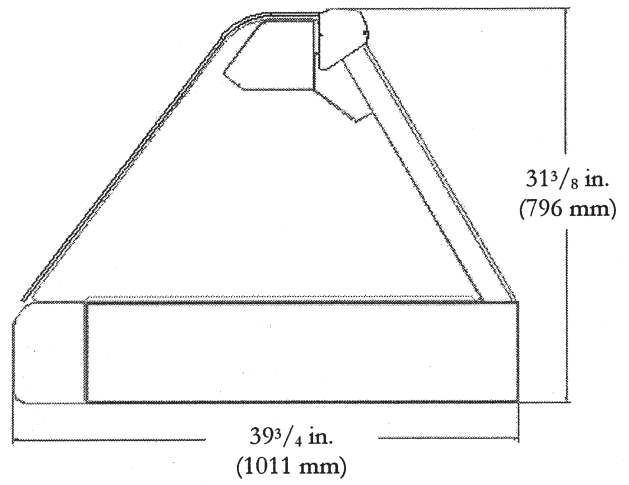

Vision Profile

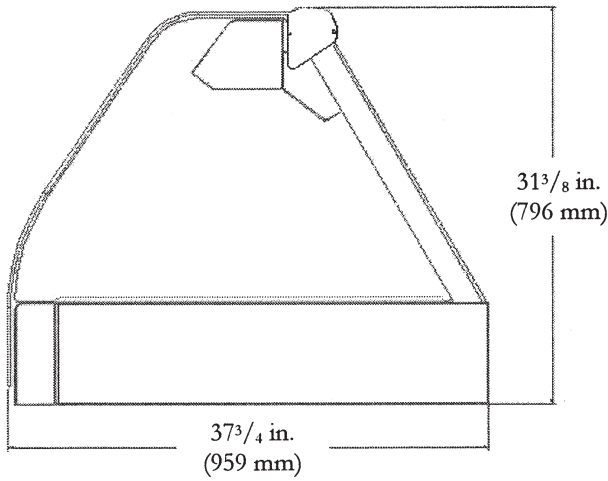

Advantage Profile

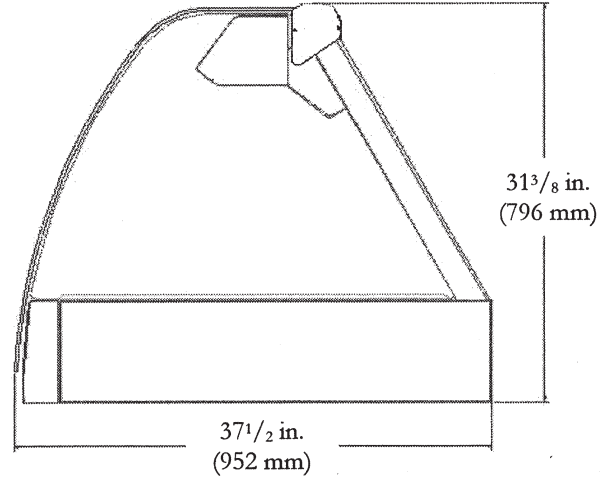

	3-well	4-well	5-well	6-well	7-well
Width	43 ¹ / ₄ in. (1099 mm)	56 ¹ / ₄ in. (1429 mm)	69 ¹ / ₄ in. (1759 mm)	82 ¹ / ₄ in. (2089 mm)	95 ¹ / ₄ in. (2419 mm)

2-6. CENTER GLASS INSTALLATION

These are the instructions for installing the center glass on units that are combination, self-serve and standard merchandisers.



1. Notice the location of the bracket on unit, as indicated.



2. Using a 3/8" socket, or nut driver, loosen the 2 acorn nuts securing the bracket, but do not remove.



3. Slide bracket off from around the 2 acorn nuts.

**2-6. CENTER GLASS
INSTALLATION
(Continued)**



4. Place glass in divider track as shown.



5. Slide bracket onto glass and align to its original position around the 2 acorn nuts.



6. Retighten the 2 acorn nuts.

2-7. SIDE GLASS
INSTALLATION

Install the side panel glass, on both sides of the unit, as follows:



Step 1

1. Pull out plunger on retainer and turn clockwise to lock open.
2. Slide the glass into the channel on the side rail, making sure the glass seats into the groove on the upright.



Step 4

3. Align the hole in the glass with the plunger of the retainer.
4. Turn the plunger of the retainer clockwise again, to lock and release the plunger in place.
5. Installation is now complete.

SECTION 3. OPERATION

3-1. INTRODUCTION

This section provides the daily operating procedure for the heated merchandiser. Read this section thoroughly before operating the merchandiser.

3-2. START-UP

1. Turn the POWER and HEAT switches to the ON position.
2. Fill water pan assembly (inside the well area) with about 1.5 gallons (5.7 liters) of water. This should provide approximately 8 hours of humidified operation under normal circumstances.
3. Allow approximately 30 minutes preheat time before placing product into the merchandiser.
4. The lower heat controls are located above the far left well of each full-serve section, along with the upper heat controls for that well. The air temperature is shown at all times and can be changed by using the UP and DOWN buttons. The temperature range is 140°-180° F (60°-82° C).

NOTICE

To check the actual air temperature, press the button marked “Press to view Actual Temp.” Also, if the controls are locked, the controls cannot be changed until the controls are unlocked. See Special Programming section.

5. The upper heat controls (radiant heat), are located above each well and can be individually set depending on the types of food that are being held in each well. The upper heat setting is shown at all times, and can be changed from settings of 1 to 10, by using the UP and DOWN buttons.

NOTICE

The upper heat settings read 1, 2, 3, etc. One meaning the heat is on 10% of the time, 10 meaning the heat is on 100% of the time. Settings of 9 and 10 have been designed for use when the rear doors of the unit have been removed. Use of these settings with the doors in place is not recommended.

6. As a rule, a lower radiant heat setting, such as 3 or 4, holds dense foods like macaroni and cheese or cherry cobbler. Use higher upper heat settings for less dense foods, such as fried chicken.

3-2. START-UP
(Continued)

7. The water (humidity) temperature controls are located above the water pan of each full serve section. If humidity is desired in the merchandiser, press the button marked ON to activate the water pan heater. If “Add H2O” flashes in the display, water needs to be added to the water pan. If no humidity is desired, press the OFF button so the water pan heater does not come on.

NOTICE

To prevent a false “Add H2O” code, make sure the water pan is touching the operator side of the unit, inside the well area.

8. To use a food temperature probe to monitor food, plug the probe into a receptacle located above each well inside the unit. Place the probe into the food, and press the probe button to toggle between showing the probe temperature and upper heat setting.

3-3. OPERATION WITH
PRODUCT

1. Rotate food from front to back.
2. Food in half-size pans does not hold as well as food in full size pans. Rotate pan to back of merchandiser where it is directly under upper heating elements or move food to a smaller pan that has been preheated.
3. When freshening foods such as macaroni and cheese with added water, heat the water in a clean container until it is 10° F to 20° F (6° C to 12° C) above the desired holding temperature of the food. This will keep food at a safe serving temperature. Depending on the amount of water, the temperature can drop 10° F to 20° F (6° C to 12° C) in as little as five minutes.
4. When transferring hot foods in the heated merchandiser to clean pans, preheat the clean pan. Transferring hot foods to room temperature pans can cause the temperature of the food to drop 20° F (12° C) or more, thus causing food to be at an unsafe serving temperature.
5. If operating unit with rear doors removed, it is recommended that third size pans be placed in the center section of the well for optimal holding. Food temperatures will be maintained for up to an hour with doors removed and upper heat set to 9 or 10. Remember to frequently monitor food temperatures.

**3-3. OPERATION WITH
PRODUCT (Continued)**

6. To keep hot foods from drying too fast, keep a clean misting bottle (such as you find in a garden supply store) with a mixture of 1/3 vegetable oil and 2/3 water on hand. Set the nozzle for a fine mist. Shake the vegetable oil and water mixture well. Spray surface of food immediately, shaking the bottle between each entree. The frequency with which the foods need to be misted depends upon the unique characteristics of the food, the water heat setting in the case and atmospheric conditions. Do not use this mixture on foods with a pastry crust or crumb toppings where a dry surface is desirable.
7. If prepackaging foods, place containers directly under upper heating elements (in back of the case) for maximum holding time. Upper heat may need to be increased slightly.

**3-4. SHUT DOWN AND
CLEAN UP**

1. Remove all power from the unit by unplugging the unit from the wall receptacle, or by turning off the wall circuit breaker.
2. Allow unit to cool before cleaning.
3. Remove rear doors and open front glass.
4. Remove pans, pan supports, and water pan and clean with soap and water at sink.
5. Clean all surfaces with a soft cloth, soap, and water.

CAUTION

Do not use steel wool, other abrasive cleaners or cleaners/sanitizers containing chlorine, bromine, iodine or ammonia chemicals, as these will deteriorate the stainless steel material and shorten the life of the unit.

Do not spray the unit with water, such as, with a garden hose. Failure to follow this caution could cause component failure.

**3-4. SHUT DOWN AND
CLEAN UP (Continued)**

6. Clean around electrical controls and components with a damp cloth.
7. Clean doors and glass with a non-streaking liquid glass cleaner.

CAUTION

Do not use abrasive cleaners or scratches to the glass may occur.

8. Leave doors open until ready to load and use again.

Cleaning Non-Glare Glass. Use a soft cloth, or sponge, and a non-abrasive cleaner and water. Dishwashing liquid, or similar product works well. When cleaning the inside of cases, it is recommended the doors be completely open and covered to prevent splashing onto the glass, and ruining the glass coating.

CAUTION

Do not use steel wool, scouring pads, cloth with metal thread, scrapers or other sharp tools, alkaline or acidic cleaners/sanitizers or cleansers containing flourides, as these will damage the coated surface of the glass.

3-5. LIGHT BULB REPLACEMENT



Figure 1



Figure 2



To avoid electrical shock or property damage, move the POWER switch to OFF and disconnect main circuit breaker, or unplug cord at wall receptacle.

Light bulbs and glass may be hot. Severe burns could result.

1. Raise the glass canopy and ensure that the gas shocks support its weight before proceeding.



Do Not attempt to access the bulb from the operator's side of the unit. The installer cannot easily see the bulb and socket or the adjacent radiant heaters, increasing the potential shock or burn hazard.

2. Carefully remove the old bulb and discard. Figure 1.
3. Visually inspect socket to ensure there is no debris or damage that may impede bulb installation. Figure 2.
4. Install the replacement bulb. Tighten using a gentle pressure.



To help prevent a short bulb life:

- *Do not over-tighten the bulb. Over-tightening will damage the contact end of the bulb and compress the contact tab in the socket.*
- *Do not install the bulb with the power on. During normal operation, the socket is exposed to various food related agents, such as moisture and grease. When installing a new bulb with the power on, the spark that occurs when the bulb contact touches the socket, places a deposit on the bottom of the bulb. This deposit results in a higher amp draw and shorter bulb life.*

3-6. SPECIAL PROGRAMMING

All three controls have the same capability to access the Special Program Mode. This mode includes; choosing between Fahrenheit and Celsius, reinitialize the controls, calibrating the food probe, and output tests.

To access the Special Program Mode: Press and hold the temperature button, then turn the power switch on.

1. “F” or “C” will show in the display. To toggle between Fahrenheit and Celsius, press and release the UP or DOWN buttons. (ON or OFF buttons on the humidity controls).
2. After entering the Special Program Mode, press and release the temperature button once and “int” shows in the display. Press and hold the UP or DOWN button (ON or OFF buttons on the humidity controls), and the display will count down “In3”, “In2”, “In1”. This will reinitialize the controls and set all controls to 0.
3. After entering the Special Program Mode, press and release the temperature button twice, and “Cal” shows in the display, followed by the current probe temperature. The probe can be calibrated $\pm 10^{\circ}$ F, and can be changed by using the UP and DOWN buttons. (ON or OFF buttons on the humidity controls.)
4. After entering the Special Program Mode, press and release the temperature button three times, and “P=L”, or “P=U”, shows in the display. Use the UP and DOWN buttons to toggle between L (lock) and U (unlock).
5. After entering the Special Program Mode, press and release the temperature button three times, and “OP” shows in the display. Use the UP and DOWN buttons to toggle between “888” and a blank display. “888” turns all heat outputs on, and a blank display turns them off.

SECTION 4. TROUBLESHOOTING

4-1. TROUBLESHOOTING GUIDE

Problem	Cause	Correction
Power switch ON but unit completely inoperative	<ul style="list-style-type: none"> • Open Circuit 	<ul style="list-style-type: none"> • Plug unit in • Check breaker or fuse at wall • Check 15 amp fuses • Check cord and plug for loose connection
No air heat	<ul style="list-style-type: none"> • Unit not preheated 	<ul style="list-style-type: none"> • Preheat unit with pans in place before loading product
Canopy glass fogging	<ul style="list-style-type: none"> • Water heat setting too high • Upper heat setting too low 	<ul style="list-style-type: none"> • Lower water heat setting • Raise upper heat setting
Product not holding temperature	<ul style="list-style-type: none"> • Doors left open • Heat settings too low • Product held too long • Product not placed correctly in unit 	<ul style="list-style-type: none"> • Keep doors closed except to load and unload product • Adjust heat settings • Hold product for recommended times • Place product in unit per Operation with Product section

4-2. ERROR CODES AND WARNINGS

DISPLAY	CAUSE	CORRECTION
“LO”	<ul style="list-style-type: none"> • Food probe or actual temperature is below 50°F (10°C) in calibration mode only 	<ul style="list-style-type: none"> • Allow unit to heat up, or remove food from unit
“HI”	<ul style="list-style-type: none"> • Food probe temperature above 500°F (260°C) or lower temperature 275°F (135°C), or above 	<ul style="list-style-type: none"> • Turn unit off and call a certified service technician
“E-4”	<ul style="list-style-type: none"> • Control board temperature above 140°F (60°C) 	<ul style="list-style-type: none"> • Turn unit off and call a certified service technician
“E-6”	<ul style="list-style-type: none"> • Air probe error 	<ul style="list-style-type: none"> • Check probe connection at PC board, or call a certified service technician
“E-41”	<ul style="list-style-type: none"> • Scrambled PC board memory 	<ul style="list-style-type: none"> • Press UP button to clear “E-41;” if it reappears, call a certified service technician
“E-56”	<ul style="list-style-type: none"> • Setpoint storage error 	<ul style="list-style-type: none"> • Press UP button to clear “E-56;” then turn unit OFF and back ON; if “E-56” reappears, call a certified service technician

More detailed troubleshooting information is available in the Technical Manual, available at www.hennypenny.com, or 1-800-417-8405 or 1-937-456-8405.

GLOSSARY

HENNY PENNY HOLDING CABINETS

air temperature probe	a round device located inside the cabinet that measures the inside air temperature and sends that information to the control panel
concentration ring assembly	a metal assembly located in the water pan in the bottom of the unit that helps keep an even humidity level inside the cabinet
clean water pan setpoint	a preset temperature at which a sensor warns the operator that the water pan has excessive lime deposits
control panel	the components that control the operating systems of the unit; the panel is located on the top front surface of the cabinet
deliming agent	a cleaner used to remove lime deposits in the water pan
drain valve	a device that lets the water drain from the water pan into a shallow pan on the floor; the valve should be closed while the unit is in use if humidity is desired
float switch	a device that senses low water levels in the water pan
food probe	a sensor located outside the cabinet that, when inserted into the product, communicates the temperature of the product to the control panel
food probe receptacle	the connection where the food probe is inserted in order to communicate with the control panel
humidity sensor	a device that measures the percentage of humidity inside the cabinet during use
humidity setting	a preset moisture level at which the cabinet operates; this setting is programmed at the factory but can be changed in the field
LED	an electronic light on the control panel
minimum holding temperature	the lowest temperature at which a food product can be safely held for human consumption
module	the removable top part of the cabinet that contains all of the operating system
out of water trip point	a preset temperature at which a sensor warns the operator that the water pan needs refilled
parameters	a preset group of setpoints designed for holding specific food products at certain temperature and humidity levels
power switch	the ON/OFF switch that sends electricity to the unit's operating systems; this switch does not disconnect the electrical power from the wall to the unit
pressure sprayer	a device that shoots a stream of water under pressure; this device should NOT be used to clean a holding cabinet

probe clip	a metal holder that attaches to the outside of the control panel to hold the food probe when not in use; the clip is an optional accessory
product load capacity	the highest recommended number of pounds/kilograms of food product that can be safely held in the cabinet
proof function	a program used for allowing bread to rise
relative humidity	the humidity level outside the cabinet
setpoint	a preset temperature or humidity; the setpoint is a programmable feature
system initialization	a programming process that resets factory settings
temperature setting	a preset temperature up to which the cabinet will heat; this setting is programmed at the factory but can be changed in the field
vent activation switch	an automatic control that opens and closes the vent on the rear of the cabinet to maintain the preset humidity level
vented panels	openings on the cabinet that allow air access on the sides and rear of the module
water fill line	the line marked on the inside of the water pan that shows the maximum water level to prevent overflow onto the floor
water heater sensor	a part in the water heater that sends a message to the controls when the water pan is limed up or empty
water jet	a device that shoots a stream of water under pressure; this type of device should NOT be used to clean a holding cabinet
water pan	the area in the cabinet that holds water for creating humidity inside the cabinet



**Henny Penny Corporation
P.O.Box 60
Eaton, OH 45320**

**1-937-456-8400
1-937-456-8402 Fax**

**Toll free in USA
1-800-417-8417
1-800-417-8434 Fax**

*** FM05 - 013 - F ***

Henny Penny Corp., Eaton, Ohio 45320, Revised 6-25-13

www.hennypenny.com