



HENNY PENNY®

Engineered to Last

Henny Penny

**Split Vat & Full Vat
Open Fryers – Electric**

Model LVE-202

Model LVE-203

Model LVE-204

OPERATOR'S MANUAL

REGISTER WARRANTY ONLINE AT WWW.HENNYPENNY.COM

TABLE OF CONTENTS

Section	Page
Section 1.	INTRODUCTION..... 1-1
1-1	Introduction 1-1
1-2	Proper Care 1-1
1-3	Assistance 1-1
1-4	Safety 1-2
Section 2.	INSTALLATION..... 2-1
2-1	Introduction 2-1
2-2	Unpacking..... 2-1
2-3	Selecting the Fryer Location..... 2-2
2-4	Leveling the Fryer 2-2
2-5	Ventilation of Fryer..... 2-3
2-6	Adjusting Height of Top Cap..... 2-3
2-7	Removal of Top Cap..... 2-3
2-8	Electrical Requirements 2-4
2-9	Dimensions 2-6
2-10	LonWorks Function Confirmation..... 2-7
Section 3.	OPERATION..... 3-1
3-1	Operating Components 3-1
3-2	Set-Up Mode..... 3-5
3-3	Filling or Adding Oil 3-6
3-4	Morning Start-Up Procedures 3-7
3-5	Cooking with Dedicated Display..... 3-8
3-6	Cooking with Multi-Product Display 3-9
3-7	Change from Breakfast to Lunch & Lunch to Breakfast..... 3-9
3-8	Change from Multi-Product Display to Dedicated Display 3-10
3-9	Change from Dedicated Display to Multi-Product Display 3-10
3-10	Change from Multi-Product Display to Multi-Product Display with Different Setpoint Temperatures 3-10
3-11	Auto Top-Off 3-11
3-12	Automatic Intermittent Filtration (AIF) 3-12
3-13	Maintenance Filter 3-14
3-14	Discarding Oil from Vat Using RTI..... 3-16
3-15	Discarding Oil from Vat Using Oil Discard Shuttle 3-17
3-16	Discarding Oil from Vat Using Non-RTI System..... 3-18
3-17	Changing the Filter Pad 3-19
3-18	Removing and Cleaning Basket Rest 3-21
3-19	Info Button Stats 3-22
3-20	Filter Button Stats 3-22
3-21	Temp Button Stats 3-22
3-22	Information Mode..... 3-23

TRAINING CD ON REAR COVER!!

FM05-062-F

Revised 01-17-13 - Original Instructions

TABLE OF CONTENTS (Continued)

Section	Page
Section 4.	LEVEL 1 PROGRAMMING4-1
4-1	Modifying Product Settings4-1
4-2	AIF Clock.....4-3
4-3	Deep Clean Mode.....4-4
4-4	Fryer Setup.....4-8
Section 5.	LEVEL 2 PROGRAMMING5-1
5-1	Advanced Product Settings5-1
5-2	E-Log (error code log).....5-2
5-3	Password.....5-3
5-4	Alert Tone.....5-3
5-5	Filter Aftr.....5-4
5-6	Filter Time5-4
Section 6.	TROUBLESHOOTING6-1
6-1	Troubleshooting Guide.....6-1
6-2	Error Codes6-3

SECTION 1. INTRODUCTION

1-1. INTRODUCTION

The Henny Penny open fryer is a basic unit of food processing equipment. This unit is used only in institutional and commercial food service operations.

NOTICE



As of August 16, 2005, the Waste Electrical and Electronic Equipment directive went into effect for the European Union. Our products have been evaluated to the WEEE directive. We have also reviewed our products to determine if they comply with the Restriction of Hazardous Substances directive (RoHS) and have redesigned our products as needed in order to comply. To continue compliance with these directives, this unit must not be disposed as unsorted municipal waste. For proper disposal, please contact your nearest Henny Penny distributor.

1-2. PROPER CARE

As in any unit of food service equipment, the Henny Penny open fryer does require care and maintenance. Requirements for the maintenance and cleaning are contained in this manual and must become a regular part of the operation of the unit at all times.

1-3. ASSISTANCE

Should you require outside assistance, call your local independent distributor in your area, or call Henny Penny Corp. at 1-800-417-8405 or 1-937-456-8405.

1-4. SAFETY

The Henny Penny open fryer has many safety features incorporated. However, the only way to ensure a safe operation is to fully understand the proper installation, operation, and maintenance procedures. The instructions in this manual have been prepared to aid you in learning the proper procedures. Where information is of particular importance or safety related, the words DANGER, WARNING, CAUTION, and NOTICE are used. Their usage is described below.

This appliance is not intended for use by persons (including children) with reduced physical, sensory or mental capabilities, or lack of experience and knowledge, unless they have been given supervision or instruction concerning use of the appliance by a person responsible for their safety

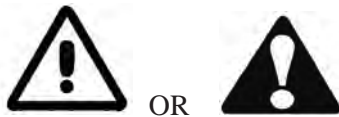

SAFETY ALERT SYMBOLS are used with DANGER, WARNING, or CAUTION which indicates a personal injury OR type hazard.



NOTICE is used to highlight especially important information.



CAUTION used without the safety alert symbol indicates a potentially hazardous situation which, if not avoided, may result in property damage.



CAUTION used with the safety alert symbol indicates a potentially hazardous situation which, if not avoided, may result in minor or moderate injury.



WARNING indicates a potentially hazardous situation which, if not avoided, could result in death or serious injury.



DANGER INDICATES AN IMMINENTLY HAZARDOUS SITUATION WHICH, IF NOT AVOIDED, WILL RESULT IN DEATH OR SERIOUS INJURY.

1-4. SAFETY (Continued)



Equipotential Ground Symbol



Waste Electrical and Electronic Equipment (WEEE) Symbol



OR



Shock Hazard Symbols



OR



Hot Surface Symbols



To Check or Confirm

Noise generated from this equipment is less than 70 dB(A)

SECTION 2. INSTALLATION

2-1. INTRODUCTION

This section provides the installation and unpacking instructions for the Henny Penny LVE fryer.

Installation of this unit should be performed only by a qualified service technician.



Do not puncture the fryer with any objects such as drills or screws as component damage or electrical shock could result.

NOTICE

Any shipping damage should be noted in the presence of the delivery agent and signed prior to his or her departure.

2-2. UNPACKING INSTRUCTIONS

1. Cut and remove the metal bands from the carton.
2. Remove the carton lid and lift the main carton off the fryer.
3. Remove corner packing supports (4).
4. Cut the stretch film from around the carrier/rack box and remove it from the top of the fryer lid.
5. Cut and remove the metal bands holding the fryer to the pallet.

CAUTION

- *Do not remove shipping brace from right side of fryer until unit is in final location as damage to fryer could result.*
- *Remove filter drain pan and JIB shelf from fryer before removing fryer from pallet or damage to the unit could result. Figure 1.*

6. Remove the fryer from the pallet.



Take care when moving the fryer to prevent personal injury. The fryer weighs approximately 600 lbs. (272 kg) to 800 lbs. (363 kg).

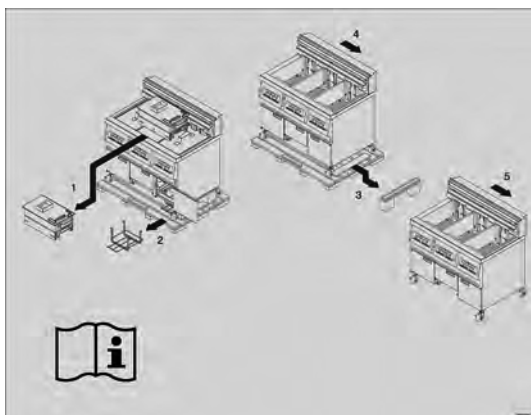

Figure 1

2-3. SELECTING THE FRYER LOCATION

The proper location of the fryer is very important for operation, speed, and convenience. The location of the open fryer should allow clearances for servicing and proper operation. Choose a location which will provide easy loading and unloading without interfering with the final assembly of food orders. Operators have found that frying from raw to finish, and holding the product in warmers provides fast continuous service. Keep in mind, the best efficiency will be obtained by a straight line operation, i.e. raw in one side and finished out the other side. Order assembly can be moved away with only a slight loss of efficiency.



To avoid fire and ruined supplies, the area under the fryer should not be used to store supplies.



To prevent severe burns from splashing hot oil, position and install fryer to prevent tipping or movement. Restraining ties may be used for stabilization.

2-4. LEVELING THE FRYER



For proper operation, the open fryer should be level from side-to-side and front to back. Using a level placed on the flat areas around the vat collar, on the middle well, and adjust the casters until the unit is level.

Casters adjustable up to 1.562 in (40mm)...see below.



2-5. VENTILATION OF FRYER

The fryer should be located with provision for venting into adequate exhaust hood or ventilation system. This is essential to permit efficient removal of steam exhaust and frying odors. Special precaution must be taken in designing an exhaust canopy to avoid interference with the operation of the fryer. We recommend you consult a local ventilation or heating company to help in designing an adequate system.

NOTICE

Ventilation must conform to local, state, and national codes. Consult your local fire department or building authorities.

2-6. ADJUSTING HEIGHT OF TOP CAP



Figure 1



Figure 2

NOTICE

Adjustable top cap to be used on all series exhaust hoods with the exception of the universal exhaust hood (UH SERIES). For UH SERIES top cap is to be removed - see Section 2-7.

On the rear shroud of the fryer is an adjustable panel that must fit up against the vent hood. Figure 1.

Using a 3/8" socket, wrench or nutdriver, loosen the 3 acorn nuts securing the panel. Figure 2.

Move the panel to fit against the vent hood and then tighten the 3 acorn nuts.

2-7. REMOVAL OF TOP CAP



Some installations (UH SERIES) may require the adjustable rear shroud to be removed.

Using a Phillip's-head screwdriver, remove two screws (one at each end) securing the rear shroud and pull shroud from unit.

2-8. ELECTRICAL REQUIREMENTS



Check the data plate, mounted on the inside of the left door, to determine the correct power supply.



This fryer must be adequately and safely grounded (earthed) or electrical shock could result. Refer to local electrical codes for correct grounding (earthing) procedures or in absence of local codes, with The National Electrical Code, ANSI/NFPA No. 70-(the current edition). In Canada, all electrical connections are to be made in accordance with CSA C22.1, Canadian Electrical Code Part 1, and/or local codes.

To avoid electrical shock, this appliance must be equipped with an external circuit breaker which will disconnect all ungrounded (unearthed) conductors. The main power switch on this appliance does not disconnect all line conductors.

(FOR EQUIPMENT WITH CE MARK ONLY!)

To prevent electric shock hazard this appliance must be bonded to other appliances or touchable metal surfaces in close proximity to this appliance with an equipotential bonding conductor. This appliance is equipped with an equipotential lug for this purpose. The equipotential lug is marked with the following symbol



**2-8. ELECTRICAL
REQUIREMENTS
(Continued)**

CABLE RESTRAINT

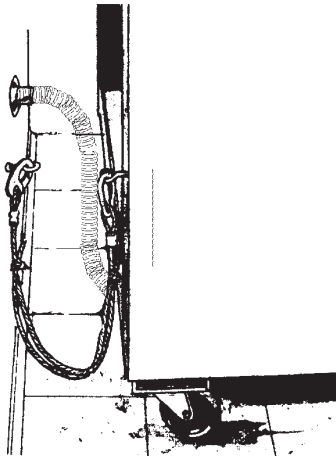

I-bolt is to be secured to the building using acceptable building construction practices.

CAUTION

DRYWALL CONSTRUCTION
Secure I-bolt to a building stud. Do not attach to drywall only. Preferred installation is approximately six inches to either side of service. Cable restraint must be at least six inches shorter than flexible conduit.

An all pole, separate disconnect switch, with proper capacity fuses or breakers must be installed at a convenient location between the fryer and the power source, and must be installed according to national and local codes. It should be an insulated copper conductor rated for 600 volts and 90° C. For runs longer than 50 feet (15.24 m), use the next larger wire size. CE units require a minimum wire size of 6 mm to be wired to the terminal block.

It is recommended that a 30 mA rated protective device such as a residual current circuit breaker (RCCB), or ground fault circuit interrupter (GFCI), be used on the fryer circuit.

Permanently connected electric fryers with casters must be installed with flexible conduit and a cable restraint, when installed in the United States. See illustration at left. Holes are available in the rear fryer frame for securing the cable restraint to the fryer. The cable restraint does not prevent the fryer from tipping.

The fryer is supplied with 2 different, 7 ft. (2.13 m) power cord assemblies. The cord assembly with the NEMA L21-20P twistlock plug is wired specifically for McDonald's Hood Interlock Receptacle only, and supplies power to the controls.



The other power cord, supplying power to the heating system, uses NEMA 15-60P Straight Plug, and each vat has its own power cord assembly.



The supply power cords shall be oil-resistant, sheathed flexible cable, no lighter than ordinary polychloroprene or other equivalent synthetic elastomer-sheathed cord.

2-9. DIMENSIONS

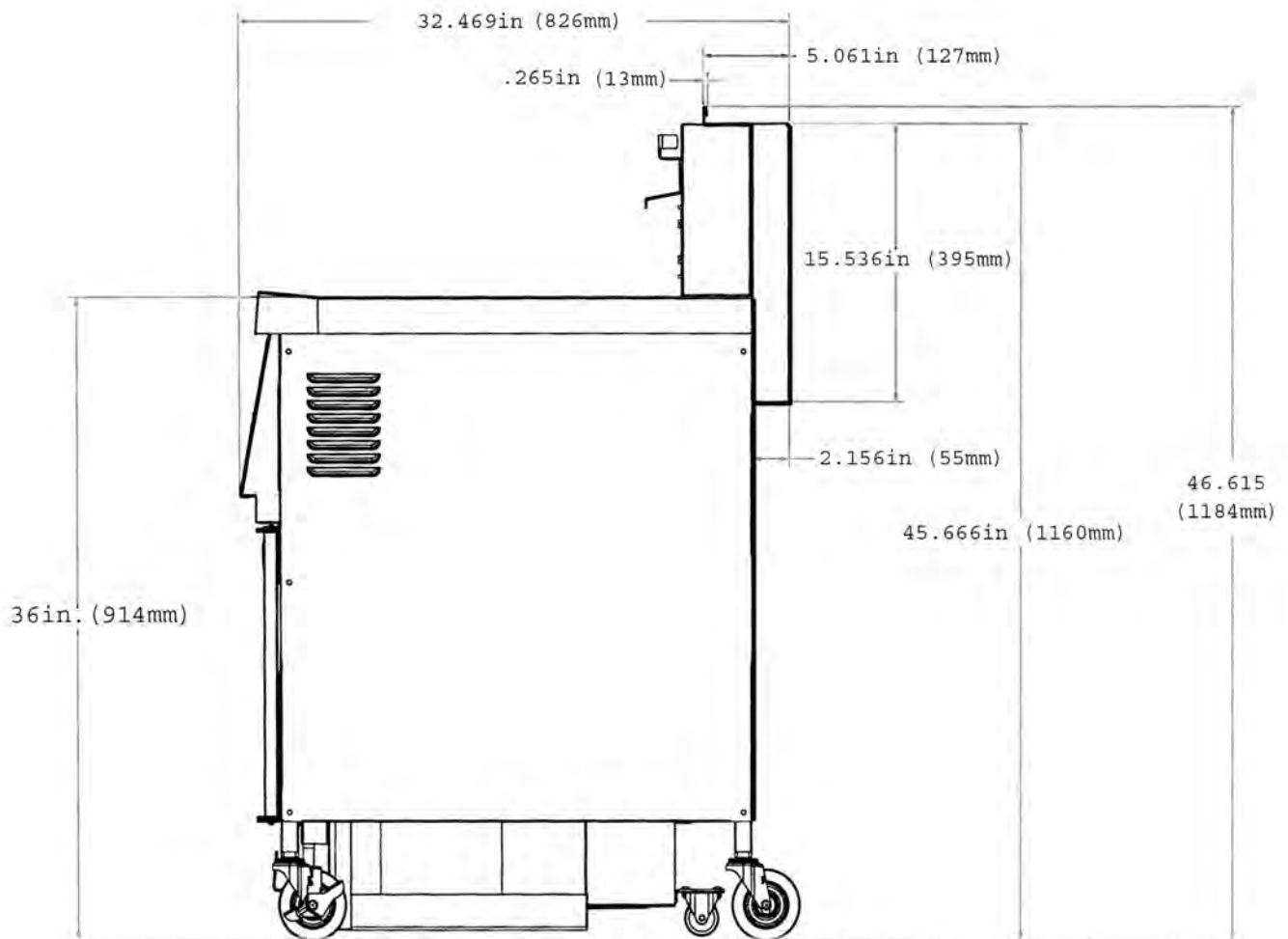
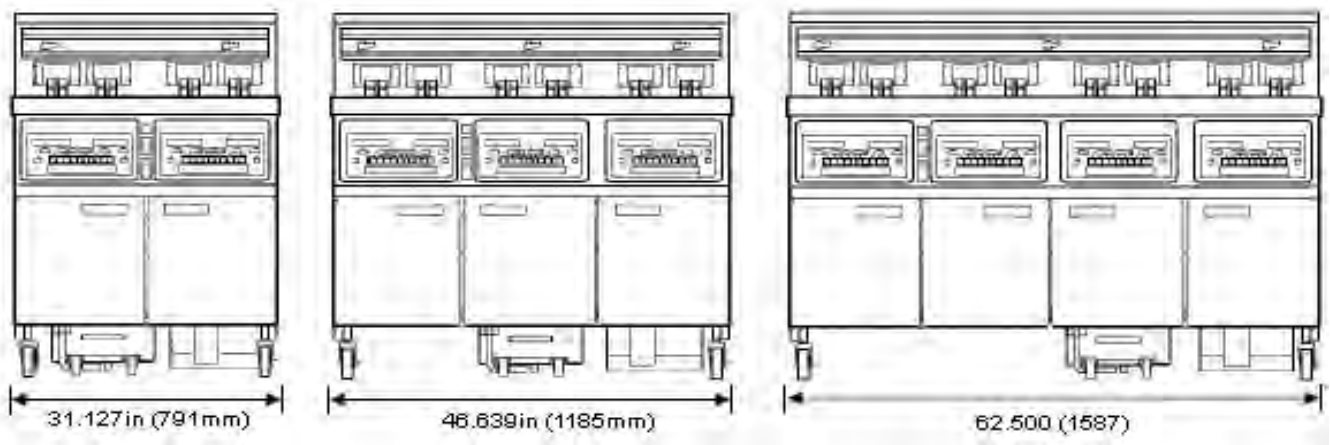





NOTICE

Casters adjustable up to 1.562 in (40mm)

**2-10. LONWORKS FUNCTION
CONFIRMATION**



Once the installation of the Henny Penny fryer is complete, perform this procedure to verify that the LonWorks control in the LVE is communicating with the computer console in the store.

1. Access the LonWorks system on the store's computer console.
2. Turn the Main Power switch to the ON position on the Henny Penny LVE fryer.
3. On one of the fryer controls, press both   buttons and "1. E-LOG" shows in the display.
4. Press  button until "9. COMM" & "LONWORKS ✓" show in the displays. (If "LONWORKS ---" shows in display, the LonWorks control is not being acknowledged by the main controls.)
5. Press  button twice and "SRVC" & "PIN" show in the displays. Press button under "SRVC".
6. From the store's console, click the WINK DEVICE button and the displays on ALL LVE controls should flash, verifying that the system is working properly.

NOTICE

If the the fryer and the store's computer console is not communicating, please contact the Technical Support Department at 1-800-417-8405, 1-937-456-8405, or technicalservice@hennypenny.com.

SECTION 3. OPERATION

3-1. OPERATING COMPONENTS Refer to explanations on the next pages.

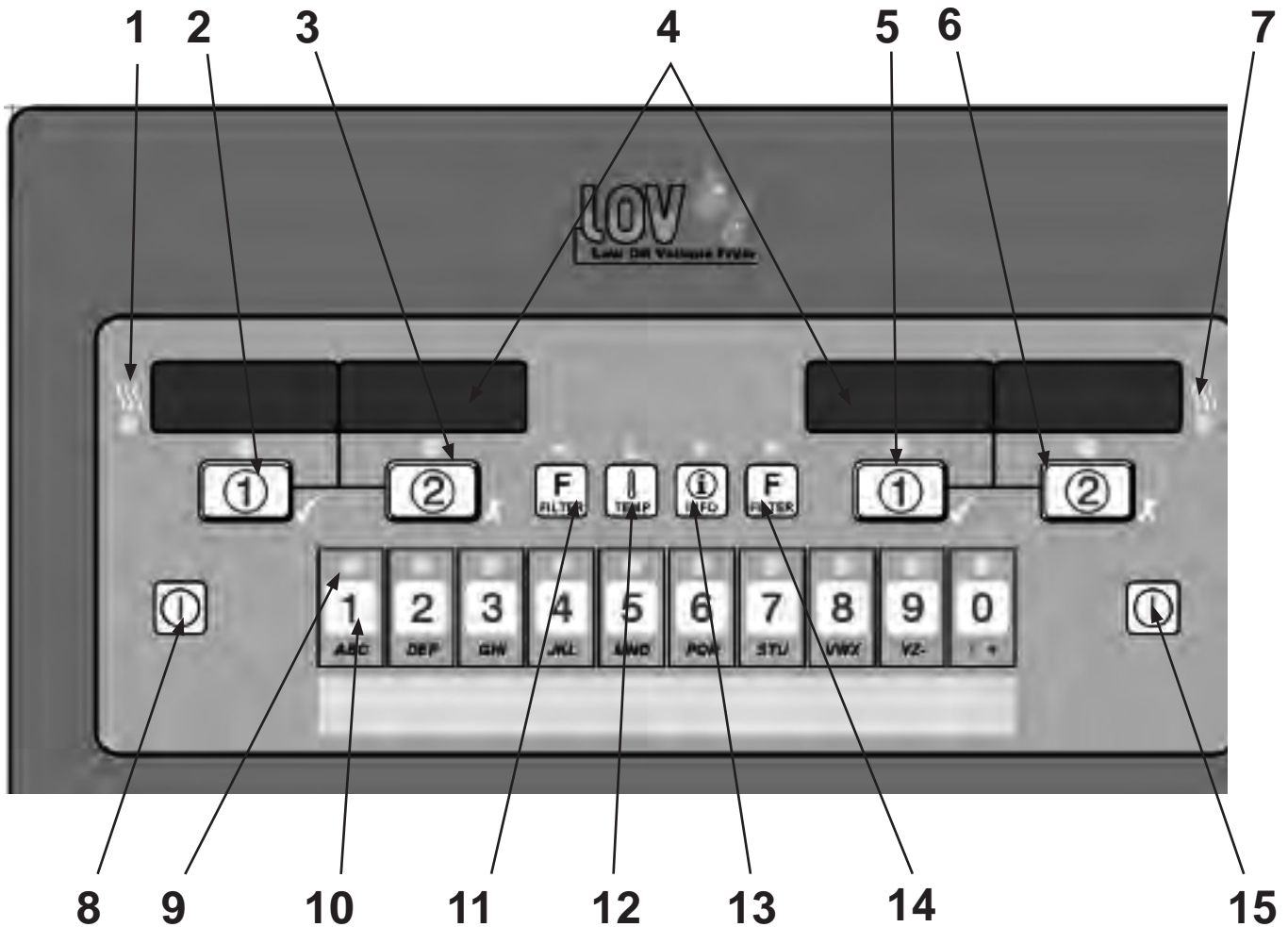

Figure 3-1

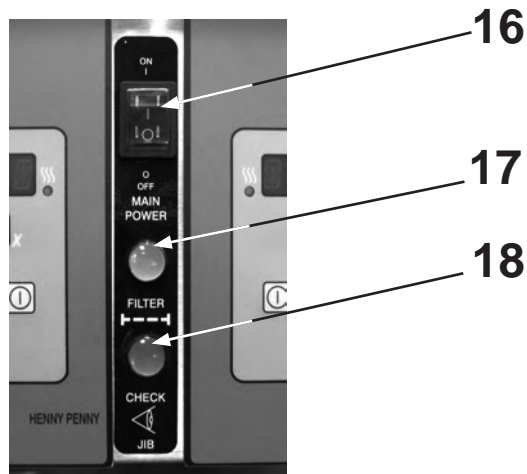



















Figure 3-2

3-1. OPERATING COMPONENTS
(Continued)

Refer to Figures 3-1 & 3-2 in conjunction with the description of the functions below.

Fig. No.	Item No.	Description	Function
3-1	1		This LED lights when the control calls for heat for the left vat(s), and the elements come on and heat the oil
3-1	2		During normal operation, press this button to start and stop cook cycles for the left basket; press to change displayed product; also used for ✓ to indicate YES or to confirm
3-1	3		During normal operation, press this button to start and stop cook cycles for the left basket; press to change displayed product; also used for X to indicate NO or cancel
3-1	4	Digital Display	Digital Display Shows the product codes; shows the timer countdown during cook cycles; shows the prompts during the filter modes; shows the selections in the Program Mode; shows the temperature of the oil by pressing  ; shows error codes (also displays in several languages)
3-1	5		During normal operation, press this button to start and stop cook cycles for the right basket; press to change displayed product; press to confirm prompts in the filter modes; also used for ✓ to indicate YES or confirmation
3-1	6		During normal operation, press this button to start and stop cook cycles for the right basket; press to change displayed product; press to deny prompts in the filter modes; also used for X to indicate NO or cancel
3-1	7		This LED lights when the control calls for heat for the right vat(s), and the elements come on and heat the oil
3-1	8		Press to turn on and off the heat system for the left vat(s)
3-1	9		Each product button LED lights when that particular product has been selected
3-1	10		Press to select the desired product; press, during naming a product, to place the letters under the button, in the name

3-1. OPERATING COMPONENTS
(Continued)

Fig. No.	Item No.	Description	Function
3-1	11 & 14		Used in the Programming and Filtering Modes; also used for ◀ or ▶ buttons ; press to view the following filtering stats: a. the number of cook cycles before next filter b. time and date of last filter cycle c. the number of hours the existing filter has been used
3-1	12		Used in the Programming Modes; used in the Filtering Modes; used in filling and emptying the vats; also used for ▲ button; press to view the following temperature stats: a. actual oil temperature in each vat b. setpoint temperature for each vat
3-1	13		Used in the Programming Modes; also used for ▼ button; press to display the following fryer information and stats: a. recovery information for each vat b. selected primary and secondary display languages
3-1	15		Press to turn on and off the heat system for the right vat(s)
3-2	16		When turned to the ON position, power is supplied to the controls and filter pumps
3-2	17		When lit blue  , indicates an Automatic Intermittent Filtration should be done at this time
3-2	18		When lit amber, indicates the JIB needs filled or replaced

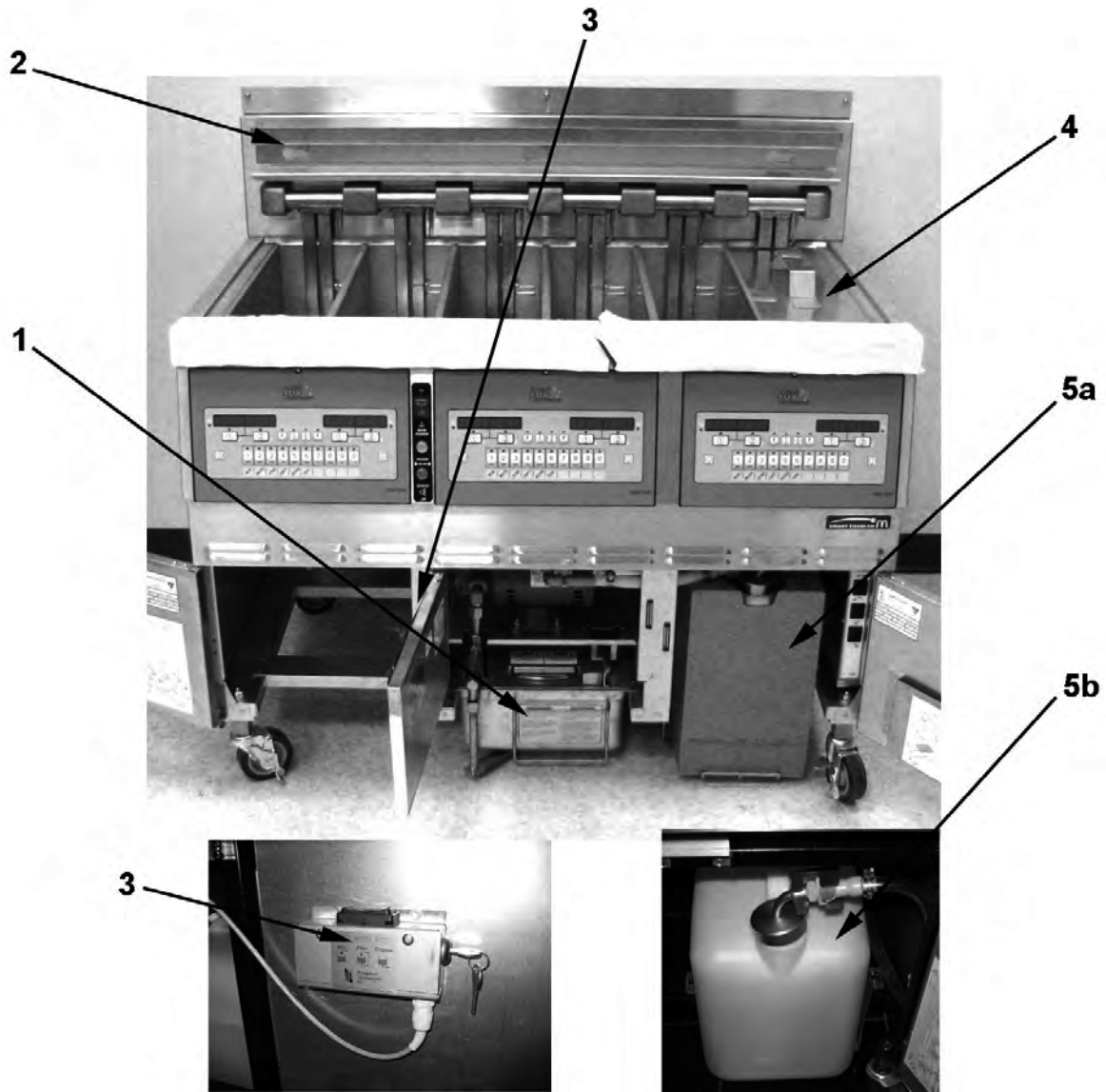





Figure 3-3

Fig. No.	Item No.	Description	Function
3-3	1	Filter Drain Pan Assy.	Oil is drained into this pan and then is pumped through filters to help prolong the use of the oil
3-3	2	Basket Rest	The baskets hang on this when not in use, or to drain the product after a cook cycle
3-3	3	RTI Switch	Only on fryers that have the RTI System at the location
3-3	4	Vat Covers	Covers the vat when not in use
3-3	5a	JIB	Jug-in-a-Box for locations without RTI systems; holds oil
3-3	5b	JIB	Jug for locations with RTI systems; holds oil

3-2. SET-UP MODE



Upon initial start-up, the controls will ask to confirm the settings for the fryer.

When the main power switch is turned on, “OFF” shows in both displays. Press  on either side and *SETUP* *MODE* shows in the displays, followed by, “LANGUAGE” on the left display, “ENGLISH” on the right display.

Use  or  buttons to change the operation display to, “FRANCAIS”, “CAN FREN”, “ESPANOL”, “PORTUG”, “DEUTSCHE”, “SVENSKA”, “РУССКИЙ”.

Press  to continue with the other set-up items which include:

- ZONE - USA, EUROPE or OTHER
- TEMP FORMAT - °F or °C
- TIME FORMAT - 12-HR OR 24-HR
- ENTER TIME - Time of day (use product buttons to change)
- ENTER TIME - AM OR PM
- DATE FORMAT - US OR INTERNATIONAL
- ENTER DATE - Today’s date (use product buttons to change)
- FRYER TYPE - GAS or ELEC
- VAT TYPE - FULL OR SPLIT
- BULK OIL DISPOSE - 1.NO; 2.RTI; 3.OTHER
- BULK OIL SUPPLY - YES/NO (BULK has RTI system)
- DAYLIGHT SAVING TIME - 1.OFF; 2.US (2007 & after); 3.EURO; 4.FSA (US before 2007)

Unless otherwise indicated, use  or  to change settings.

NOTICE

The Setup Mode can also be accessed from Level 1 programming. See Section 4-4.

3-3. FILLING OR ADDING OIL



Figure 1



Figure 2



Figure 3

CAUTION

The oil level must always be above the heating elements when the fryer is heating and at the oil level indicators on the rear of the vat. Failure to follow these instructions could result in a fire and/or damage to the fryer. Solid oil is not recommended. Solid oil could cause clogging and pump failures.

1. It is recommended that a high quality liquid frying oil be used in the open fryer. Some low grade oils have a high moisture content which causes foaming and boiling over.

WARNING BURN RISK

Wear gloves to avoid severe burns when pouring hot oil into vat. Oil and all metal parts that are in contact with the oil are extremely hot, and take care to avoid splashing.

2. Oil Capacities:

Full-size vats = 15 quarts/30 lbs (14.2 liters/13.6 kg)





Split-vats = 7.5 quarts/15 lbs (7.1 liters/6.8 kg).

Fish vat (deep split-vat) = 10 quarts/20 lbs (9.5 liters/9.1 kg)

All vats have 2 level indicator lines inscribed on the rear wall of the vat, in which, the upper-most line shows the oil at the proper level when heated. Figures 1 & 2.

3. Cold oil should be filled to the lower indicator.

Filling vat using the RTI system

1. Turn the main power switch to the ON position.
2. Place basket support inside of vat. Figure 3.
3. Press and hold  (on either side) until display shows *FILTER MENU*, along with 1.AUTO FILTER?
4. Press and release  button 5 times until display shows “6.FILL POT FROM BULK”. (Must be set to “BULK” in Set-Up Mode)
5. Press  button and display shows “FILL POT FROM BULK YES NO”. Press and hold  button again to fill vat and display shows “FILLING”.
6. Once vat is full, release  button and press **X** button twice to exit and return to normal operation.

3-4. MORNING START-UP PROCEDURES





Figure 1

1. Place basket support inside of vat. Figure 1.

CAUTION

Failure to place the basket supports in the vats could cause damage to the burner tubes in gas fryers, or the elements in electric fryers.

2. Make sure vat is filled with oil to the proper level.
3. Move power switch to the ON position and then press  to turn on heat for the desired vat. If display shows “IS POT FILLED?” make sure oil is at the proper level (see Section 3-2) and then press  button for “YES”.

Unit automatically goes into the Melt Cycle until the oil temperature reaches 180°F (82°C) and then control automatically exits the Melt Cycle.

NOTICE

The Melt Cycle may be bypassed, if desired, by pressing  button or **X** button and holding it for 5 seconds.

The control then shows “EXIT MELT” “YES NO”. Press  button for “YES” and vat heats continuously until the set-point temperature is reached.

CAUTION



Do not bypass the Melt Cycle unless enough oil has melted to completely cover all of the elements. If the Melt Cycle is bypassed before all elements are covered, excessive smoking of oil, or a fire will result.

DANGER OVERFLOW RISK

DO NOT OVERLOAD, OR PLACE PRODUCT WITH EXTREME MOISTURE CONTENT INTO THE BASKETS. 3 LBS. (1.4 KG.) IS THE MAXIMUM AMOUNT OF PRODUCT PER FULL VAT AND 1-1/2 LBS. (.68 KG.) FOR THE SPLIT VATS. FAILURE TO FOLLOW THESE INSTRUCTIONS CAN RESULT IN OIL OVERFLOWING THE VAT WHICH COULD CAUSE SERIOUS BURNS, PERSONAL INJURY, FIRE AND/OR PROPERTY DAMAGE.

3-5. COOKING WITH DEDICATED DISPLAY

A dedicated display means, one product always shows in the display of a particular vat.



1. Once out of the Melt Cycle, LOW TEMP flashes until the setpoint temperature has been reached. No cook cycles can be started while “LOW TEMP” shows in the display. Once the set-point temperature has been reached, the product name now shows in the display, ex: NUGGETS, and product now can be placed in the oil.
2. Press a timer button  or .
3. Display shows the name of the product cooking (ex: “NUG”) and the timer counting down.
4. When cook cycle is complete, an alarm sounds and display shows “PULL”.
5. Press the timer button under PULL to stop the alarm, and lift basket from vat.
6. If a Quality Timer (hold timer) has been programmed, the hold time starts automatically when the user presses the timer button to end the cook cycle. While the quality timer counts down, the display shows the three-digit product abbreviation followed by “Qn”, where “n” is the number of minutes remaining.
ex: “FRY” / “Q5” / “FRY” / “Q5” / “FRY” / “Q4”, etc.

At the end of the timer countdown, the control beeps and the display shows “QUAL” followed by the three-digit product name: “QUAL” / “FRY” / “QUAL” / “FRY”. Press the timer button to cancel the timer.

NOTICE





To change the dedicated product, press the desired product button, ex:  and “<<<< >>>>” shows in the display.



Then press and hold (for 5 seconds) the timer button  or  for the vat to be used. The product name now shows in the display, ex “HASH BRN”.

3-6. COOKING WITH MULTI-PRODUCT DISPLAY



A multi-product display means, a product must be selected before starting a cook cycle in a particular vat.

1. Once out of the Melt Cycle, LOW TEMP flashes until the setpoint temperature has been reached. Then the display shows “---- ----”.
2. Press a product button, for ex:  and product now can be placed in the oil.
3. Display shows “FR FRIES”. If display shows “<<<< >>>>”, oil temperature is not correct for that product. Either select another product, or press and hold  or  for 5 seconds.
4. Press a timer button  or .
5. When cook cycle is complete, the alarm sounds and display shows “PULL”.
6. Press the timer button under “PULL”, to stop alarm. Display then shows “---- ----”, or if a quality timer (hold time) has been programmed, the display shows the timer counting down (see step 6, Section 3-5).



3-7. CHANGE FROM BREAKFAST TO LUNCH or LUNCH TO BREAKFAST

This procedure is basically changing the product being cooked in a vat with a dedicated display.

Breakfast to Lunch

1. Press product button, for ex: .
2. Display shows “<<<< >>>>”.
3. Press and hold a timer button  or  for 5 seconds and then “FR FRIES” shows in display.

Lunch to Breakfast



1. Press product button, for ex: .
2. Display shows “<<<< >>>>”.
3. Press and hold a timer button  or  for 5 seconds and then “HASH BRN” shows in display.

NOTICE

During a cooking cycle, if an attempt is made and fails to change a product in a dedicated display or multi-product display, the set-point temperatures of the products are not the same. Wait until the cook cycle is complete, and then perform the change procedure.



**3-8. CHANGE FROM
MULTIPRODUCT
DISPLAY TO A
DEDICATED DISPLAY**

The display shows “---- ----” if in the Multi-Product Display Mode and can be changed to a dedicated display.

1. Press a product button, for ex: .
2. The display shows “FR FRIES” if the set-point of the vat matches the product, or the display shows “<<<< >>>>” if it doesn’t.
3. Press and hold a timer button  or  for 5 seconds until control beeps.
4. Release the timer button and display shows “FR FRIES”, indicating the change has been made to the Dedicated Display Mode.

**3-9. CHANGE FROM
DEDICATED DISPLAY
TO A MULTI-
PRODUCT DISPLAY**





This procedure is simple, and always works (will not be rejected) because it never tries to change the set-point temperature.

1. Press and hold a timer button  or  for 5 seconds until control beeps.
2. Release the timer button and display shows “---- ----”, indicating the change has been made to the Multi-product Display Mode.

NOTICE

Only products programmed for this set-point temperature will be able to be selected for cooking.

**3-10. CHANGE FROM
MULTI-PRODUCT
DISPLAY TO A
MULTI-PRODUCT
DISPLAY WITH
DIFFERENT
SET-POINT
TEMPERATURES**

1. Press a product button, for ex: .
2. The display shows “FR FRIES” if the set-point of the vat matches the product, or the display shows “<<<< >>>>” if it doesn’t.
3. Press and hold a timer button  or  for 5 seconds until control beeps.
4. Release the timer button and display shows “FR FRIES”, indicating the change has been made to the Dedicated Display Mode.
5. Press and hold a timer button  or  for 5 seconds until control beeps.
6. Release the timer button and display shows “---- ----”, indicating the change was made to the Multi-Product Display Mode, using the set-point of french fries, in this example.

3-11. AUTO TOP-OFF

During normal operation, the control automatically monitors the oil level in the vat. If the control senses the oil level too low, the unit pumps oil from the JIB into the vat to keep the oil at the proper level.



Figure 1



Figure 2

Filling the JIB using the RTI system

1. Control displays “*CHECK* *JIB*” and amber light is lit on the front of the fryer. Figure 1.

2. Open the door, that has the RTI switch (Figure 2). Press & hold the ADD side of the RTI switch to add oil to the JIB.



Figure 3

Replacing the JIB (locations without RTI)

1. Control displays “*CHECK* *JIB*” and amber light is lit on the front of the fryer. Figure 1.

2. Open right door and pull JIB from unit. Pull the cap from top of JIB and discard empty JIB and replace with full one. Figure 3.

**3-12. AUTOMATIC
INTERMITTENT
FILTRATION (AIF)**



Figure 1

NOTICE

AIF is NOT available on fish vats (deep split-vats). Fish vats are to be filtered only once, at the end of the day.

1. During normal operation and after a certain number of cook cycles, the blue light illuminates on the front of the fryer (Figure 1), and the control periodically shows “FLTR NOW?” “YES NO”.
2. If filtering is desired, press ✓ button for YES and display shows “*SKIM VAT*” followed by “CONFIRM” “YES NO”.
3. Once the crumbs are skimmed off the top of the oil, press ✓ button for YES and display shows “DRAINING” drain opens and the oil drains from the vat. (If control suspects oil in drain pan “CAUTION IS THERE OIL IN PAN? YES NO” may show in display. Make sure drain pan is empty before proceeding.)

NOTICE

If filtering is NOT desired, press X button and the AIF (Automatic Intermittent Filter) is cancelled. The blue light goes out and the controls return to normal operation. The controls will suggest filtering after several more cook cycles.

4. If display shows “VAT EMTY”, followed by, “YES NO”, check that drain is clear and vat is empty. Press ✓ button and display shows “WASHING” followed by “FILLING”.

NOTICE

The WASH step of the first Autofilter on a new filter pad lasts an extra 45 seconds to “break in” the pad.

5. If the display shows “IS POT FILLED?” “YES NO”, make sure vat is full and then press ✓ button for YES and control returns to normal operation.

Filter Error

6. If oil has not pumped back to the proper level in vat during the AIF process, press X button for NO and pump runs for 30 seconds.
7. Display shows “IS POT FILLED?” “YES NO”. Press ✓ button and control returns to normal operation. Press X button and pump runs for another 30 seconds. You can try to fill the vat 3 times.

3-12. AUTOMATIC
INTERMITTENT
FILTRATION (AIF)
(Continued)

8. After trying to fill the vat 3 times without success, the controls then shows “CHANGE FILTER PAD?” “YES NO”. If changing the filter pad at this time, press ✓ and change filter pad following the procedures in the Changing the Filter Pad or Paper Section. Controls return to normal operation.

If filter pad is to be changed at a later time, press X button and “CHANGE FILTER PAD?” reminder shows 15 minutes later.

9. During the next AIF with a new filter pad, if the vat is not filled after 3 tries, the display shows “FILTER SERVICE REQUIRED-SEE TROUBLESHOOTING GUIDE”.

If the “Service Required” message appears, then every 15 minutes the display shows “FILTER PROBLEM FIXED? YES NO”. If the problem has not been fixed, press X button. Once the problem has been resolved, press ✓ and controls return to normal operation.

NOTICE

To help ensure the vat fills completely, make sure filter pan is cleaned at least daily, filter pad is changed, make sure JIB is full and that “O” rings on the filter pan are in good condition.





**3-13. MAINTENANCE
FILTER**



Put on protective gear: Be sure to use all McDonald’s approved safety equipment including, apron, face shield and gloves. **Never begin filtering until you’re wearing all safety gear. Hot oil can cause severe burns.**

1. **Check Filter Pan:** A new filter pad should be used on the first filter of each day, but the same filter pad can be used the rest of the day, except for fish vats. **After filtering a fish vat, the filter pad MUST be changed.**

Make sure that the filter pipe is tightly connected, and that the filter drain pan is as far back under fryer as it will go and the filter pan cover is in place. If the filter drain pan or cover is not in place, the display shows “CHK PAN”.

2. **Make sure oil is hot:** The best results are obtained when the frying oil is filtered at the normal frying temperature.
3. Press and hold  (on either side) until display shows “1.AUTO FILTER?”.
4. Press and release  button and display shows “2.MAINT FILTER?”.
5. Press  button for YES and display shows “MAN FILTER” “YES NO”.
6. Press  button for YES to drop oil and display shows “DRAINING” and the oil drains from the vat, or press  button for NO and controls return to normal operation. (If control suspects oil in drain pan “CAUTION IS THERE OIL IN PAN? YES NO” may show in display. Make sure drain pan is empty before proceeding)
7. Once oil has drained from vat, use the lift tool and lift the hinged element from the vat to clean the bottom of the vat. Figure 1.

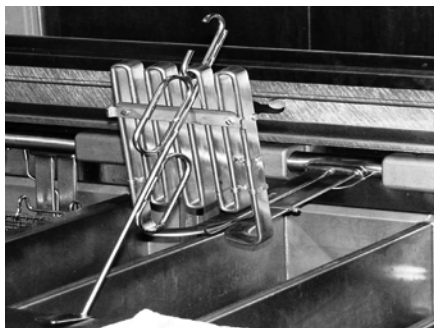

Figure 1



Use protective cloth or gloves when lifting the element. The element may be hot and burns could result.



Avoid putting the lift tool in the center of the elements, at the same area as the high limit bulb, or damage to the high limit could result.

3-13. MAINTENANCE
FILTER (Continued)

8. Use the Hi-Temp Pad Holder, pad, and a small amount of KAY QSR Fryer Cleaner to scrub the walls, corners and bottom of the inside of the vat. Use the Hi-Temp Detail Brush to remove soil built up and debris from coils, corners of vats and other hard-to-reach areas. Be careful not to damage sensing probes.

CAUTION

Do not use steel wool, other abrasive cleaners or cleaners/ sanitizers containing chlorine, bromine, iodine or ammonia chemicals, as these will deteriorate the stainless steel material and shorten the life of the unit.

Do not use a water jet (pressure sprayer) to clean the unit, or component damage could result.

9. Once vat is clean, display shows “SCRUB VAT COMPLETE?” “YES NO”, press ✓ button for YES, display shows “WASH VAT” “YES NO”.
10. Lower element, press ✓ button and display shows “WASHING”. Oil circulates through vat and once wash cycle is complete, display shows “WASH AGAIN?” “YES NO”.

NOTICE

The WASH step of the first Maintenance Filter on a new filter pad lasts an extra 45 seconds to “break in” the pad.

11. Press ✓ button for YES if another wash is needed, if not, press X button for NO and display shows RINSING and fryer automatically rinses vat. When rinsing is complete, display shows “RINSE AGAIN?” “YES NO”.
12. Press ✓ button for YES if another rinse is needed, otherwise press X button for NO. The display shows “POLISH?” “YES”.
13. Press ✓ button for YES, oil is “polished” by circulating it through filtering system and display shows “5:00 STOP”, and the oil is circulated through the filter system for 5 minutes.
14. Once the oil is polished, the display shows “FILL VAT?” “YES”. Press ✓ button and display shows “FILLING” and vat fills with oil.
15. Once full, the display shows “IS POT FILLED?” “YES NO”. Press ✓ button for YES and fryer returns to normal operation.

If X button is pressed, the display shows “FILLING” and pump runs for 30 seconds and stops, the display shows “IS POT FILLED?” “YES NO”. After 3 tries, display shows “ADD” “QUIT”. Press and hold ✓ button to fill pot and release. Press X button and display shows “IS POT FILLED?” “YES NO”. Press ✓ button and fryer returns to normal operation.

**3-14. DISCARDING OIL
FROM VAT USING
RTI**



WITH PROLONGED USE, THE FLASHPOINT OF SHORTENING IS REDUCED. DISCARD SHORTENING IF IT SHOWS SIGNS OF EXCESSIVE SMOKING OR FOAMING. SERIOUS BURNS, PERSONAL INJURY, FIRE, AND/OR PROPERTY DAMAGE COULD RESULT.

1. Press and hold  (on either side) until display shows “*FILTER MENU*”, along with “1.AUTO FILTER?”.
2. Press and release ▼ twice until display shows 3.DISPOSE.
3. Press ✓ button and display shows DISPOSE? “YES NO”.
4. Press ✓ button and display shows “DRAINING” and oil drains into the filter drain pan. (If control suspects oil in drain pan “CAUTION IS THERE OIL IN PAN? YES NO” may show in display. Make sure drain pan is empty before proceeding)
5. Display then shows “VAT EMTY” “YES NO”.
6. Press ✓ button and display shows “CLEAR OLD OIL FROM OIL LINES” “✓ =PUMP” “X =DONE”. To make sure no old oil remains in the oil lines, press and hold ✓ button for a few seconds. Once lines are clear, press X button and display shows “CLN VAT COMPLETE” “YES NO”. Once vat is clean, press ✓ button.
7. The drain closes and display shows “FILL POT FROM BULK” “YES NO”. Open the door, that has the RTI switch (Figure 1) and press and hold the “DISPOSE” button on the RTI switch until the filter drain pan is empty.
8. To refill the vat, press and hold ✓ button until cold shortening is up to the lower oil indicator in vat, per Section 3-3.
9. Press X button and display shows “IS POT FILLED” “YES NO”. If vat is full, press ✓ button and controls return to normal operation. If vat is not full, press X button, and controls return to step 8.



Figure 1

3-15. DISCARDING OIL FROM VAT USING OIL DISCARD SHUTTLE



Figure 1



Figure 2

1. Open center door and pull the drain pan assembly from under fryer and replace with oil discard shuttle. Figures 1 & 2.
 2. Press and hold  (on either side) until display shows “*FILTER MENU*”, along with “1.AUTO FILTER?”.
 3. Press and release ▼ button twice until display shows “3.DISPOSE”. Press ✓ button and display shows “DISPOSE?” “YES NO”. (If control suspects oil in drain pan “CAUTION IS THERE OIL IN PAN? YES NO” may show in display. Make sure drain pan is empty before proceeding)
 4. Press ✓ button and display shows “IS DISPOSAL UNIT IN PLACE? “YES NO”.
 5. With discard shuttle rolled into place, press ✓ button and display shows “DRAINING”. Oil now drains from the vat into the shuttle.
 6. Display shows “VAT EMTY “YES NO”. Verify that vat is empty, and press ✓ button.
 7. Display shows “CLEAR OLD OIL FROM OIL LINES” “✓ =PUMP” “X =DONE”. To make sure no old oil remains in the oil lines, press and hold ✓ button for a few seconds. Once lines are clear, press X button.
 8. Display shows “CLN VAT COMPLETE” “YES NO”. Once vat is clean, press ✓ button.
 9. Display shows “MANUAL FILL POT”, followed by “IS POT FILLED” “YES NO”. Fill the vat to the lower indicator line on the rear of the vat and then press ✓ button. (See **Filling or Adding Oil (locations without RTI)** instructions from Section 3-2.
- Controls return to normal operation.
10. Remove the discard shuttle from under fryer and replace with the filter pan assembly.

**3-16. DISCARDING OIL
USING NON-RTI
SYSTEMS**



WITH PROLONGED USE, THE FLASHPOINT OF SHORTENING IS REDUCED. DISCARD SHORTENING IF IT SHOWS SIGNS OF EXCESSIVE SMOKING OR FOAMING. SERIOUS BURNS, PERSONAL INJURY, FIRE, AND/OR PROPERTY DAMAGE COULD RESULT.

1. Remove pipe plug from the DISPOSE OIL OUT elbow in the rear of the fryer, and attached dispose plumbing to the elbow; 1/2 inch diameter, standard NPT threads.
2. Be sure the BULK OIL DISPOSE is set to OTHER in the SETUP Mode. See Section 4-4.
3. Press and hold  (on either side) until display shows “*FILTER MENU*”, along with “1.AUTO FILTER?”.
4. Press and release ▼ twice until display shows 3.DISPOSE.
5. Press ✓ button and display shows “DRAIN VAT” “YES NO”.
6. Press ✓ button and display shows “DRAINING” and oil drains into the filter drain pan. (If control suspects oil in drain pan “CAUTION IS THERE OIL IN PAN? YES NO” may show in display. Make sure drain pan is empty before proceeding)
7. Display then shows “VAT EMTY” “YES NO”.
8. Press ✓ button and display shows “CLEAR OLD OIL FROM OIL LINES” “✓ =PUMP” “X =DONE”. To make sure no old oil remains in the oil lines, press and hold ✓ button for a few seconds. Once lines are clear, press X button and display shows “CLN VAT COMPLETE” “YES NO”. Once clean, press ✓ .
9. Display shows “DISPOSE” and then “✓ =PUMP” “X=DONE”. Press ✓ button.
10. Display shows “DISPOSING...” “X=STOP and oil is pumped from drain pan to bulk oil container. When all oil is pumped from pan, press X button (STOP).
11. Display shows “DISPOSE” and then “✓ =PUMP” “X=DONE”.
12. Press X button and display shows “MANUAL FILL VAT”, followed by “IS POT FILLED?”, along with “YES NO”. Fill the vat to the lower indicator line on the rear of the vat. See Filling or Adding Oil instructions from Section 3-3

3-17. CHANGING THE FILTER PAD



Figure 1



Figure 2

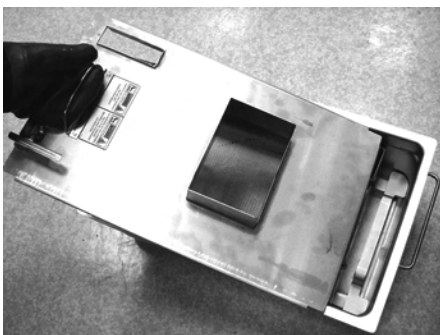

Figure 3

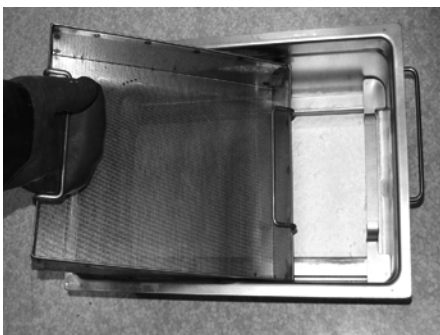

Figure 4

In order to assure good oil pumping performance, the filter pad (or paper) should be changed at least once per day. However, in stores open 24 hours a day, the pad should be changed twice a day.

NOTICE

If the filter pad has not been changed, a reminder shows on the display, "CHANGE PAD". Press ✓ button to cancel the message, but it reappears every 4 minutes until the filter pad has been changed.

1. Make sure the main power switch is in the ON position.
2. Open the door, lift-up on the drain pan stop and pull-out the drain pan assembly, using the handle on the drain pan. Figures 1 & 2.



This pan could be hot! Use protective cloth or glove, or severe burns could result.

If the filter pan is moved while full of oil, use care to prevent splashing, or burns could result.

3. Lift the pan cover from the drain pan. Figure 3.

4. Lift the crumb basket from the drain pan. Wipe the oil and crumbs from the crumb basket. Clean the crumb basket with soap and water, then thoroughly rinse with hot water. Figure 4.

**3-17. CHANGING THE
FILTER PAD
(Continued)**

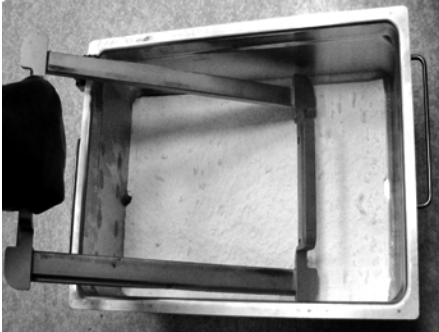

Figure 5

5. Remove the filter pad retaining ring and clean thoroughly with soap and water. Rinse thoroughly with hot water. Figure 5.



Figure 6

6. Pull the filter pad from the pan and discard pad. Figure 6.

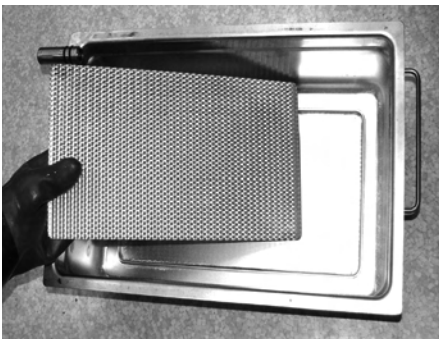

Figure 7

7. Remove the bottom screen from pan and clean thoroughly with soap and water. Rinse thoroughly with hot water. Figure 7.



Figure 8

8. Wipe the oil and crumbs from the drain pan. Clean the drain pan with soap and water, then thoroughly rinse with hot water. Figure 8.

**3-17. CHANGING THE
FILTER PAD
(Continued)**



Figure 9



Figure 10

**3-18. REMOVING AND
CLEANING BASKET
REST**



NOTICE

Be sure that the drain pan, bottom screen, crumb catcher, and the retaining ring are thoroughly dry before placing filter pad into pan as water will dissolve the filter pad.

9. Reassemble in reverse order, placing the bottom screen into the filter pan first, followed by the filter pad, retaining ring and the crumb catcher.

NOTICE

Before pushing the filter drain pan back into position, lubricate the o-rings (Figure 9) on the filter tube with cold oil.

10. Push the filter pan assembly back underneath the fryer, making sure the filter tube on the pan makes a good connection with the fitting underneath the fryer. Figure 9.
11. Make sure the drain pan stop is engaged and the fryer is now ready for normal operation. Figure 10.

The basket rest, on the rear shroud of the fryer, should be removed and cleaned periodically.

**WARNING
BURN RISK**

Use protective gloves when removing the basket rest. The basket rest may be hot and burns could result.

Grasp the basket rest with 2 hands and pull it off the “key-ways”.

Take it to a sink and clean it with soap and water. Dry thoroughly.

Clean the area behind the basket rest and then reinstall the basket rest.

3-19. INFO BUTTON STATS



Recovery Information for each Vat

Press and release  and REC shows in the left display and the recovery time that oil temperature went from 250°F (121°C) to 300°F (149°C) shows in the right display. For example,

REC	1:05
-----	------

 means it took 1 minute and 5 seconds for the oil temperature to recover to 300°F (149°C) from 250°F (121°C).

Selected Languages



2. Press and release  twice and primary language shows in the left display and secondary language shows in the right display. Press  button under either language to switch unit operation to that language.

NOTICE

If no buttons are pressed within 5 seconds in any of stats modes, the controls revert back to normal operation.

3-20. FILTER BUTTON STATS

Cook Cycles Remaining before Filtering

1. Press and release either  or  and the left display shows

F
FILTER

 or



F
FILTER

 and the right display shows “COOKS REMAIN” and the right display shows the number of cook cycles before the next auto filter. For example,



REMA IN	3	6
---------	---	---

 means after 3 more cook cycles on left vat, controls ask the operator if they are ready to filter or not. But, 6 more cook cycles remain on the right vat.

Time and Date

2. Press either  or  twice and the time-of-day and date of the most recent filter activity shows in the displays.

Filter Pad Usage

3. Press either  or  three times and the number of hours the current filter pad has been used shows in the display.

3-21. TEMP BUTTON STATS

Actual Oil Temperature

1. Press  and the actual oil temperature shows in the display, for each vat.

Set-point Temperature

2. Press  twice and SP shows in the display, along with the set-point (preset) temperature of each vat.

**3-22. INFORMATION
MODE**

This mode gathers and stores historic information on the fryer and operator’s performance. Press and hold  for 3 seconds, until *INFO* *MODE*” shows on the displays.

Press ▲ or ▼ buttons to access the steps and press ✓ button to view the statistics within each step.

This mode includes the following information:

1. **FILTER STATS** - filtering information for the last 7 days
2. **REVIEW USAGE**- information accumulated since the last time this data was manually reset
3. **LAST LOAD** - information about the most recent Cook Cycle, or the cycle presently in progress

NOTICE

Press X button to exit from the Information Mode.

1. **FILTER STATS**

Press ✓ button to select Filter Stats and then press ◀ and ▶ to select the day you want to view the stats. Then press ▲ or ▼ buttons to view the following stats:

- “FILTERED” = Number of times filtered
- “FLT BPSD” = Number of times filtering was skipped
- “FLT AVG” = Average number of cook cycles between filters

2. **REVIEW USAGE**

Press ✓ button to select Review Usage and press ▲ or ▼ buttons to view the following:

FUNCTION	DISPLAY EX:
Day the usage data was previously reset	SINCE 8:26A 4-19-10
Total number of cook cycles	TOTAL COOKS 462
Cook Cycles stopped before “PULL”	QUIT COOK 4
Number of hours the fryer was on (left)	L ON HRS 165
Number of hours the fryer was on (right)	R ON HRS 160
Reset Usage Data	RESET - YES NO

3-22. INFORMATION
MODE (Continued)

3. LAST LOAD

Press ✓ button to select Last Load (ex: -P1- = Product 1; "L1" = left, 1st product) and press ▲ or ▼ buttons to view the following:



FUNCTION	DISPLAY EX:
Product (Last product cooked)	PRODUCT P1- L1
Time and day last Cook Cycle was started	STARTED 10.25A AUG-11
Actual Elapsed cook Time (Real seconds)	ACTUAL TIME 7:38
Programmed cook Time	PROG TIME 3:00
Max Temp during Cook Cycle	MAX TEMP 327°F
Min Temp during Cook Cycle	MIN TEMP 313°F
Avg Temp during Cook Cycle	AVG TEMP 322°F
Heat On (percentage) during Cook Cycle	HEAT ON 73%
Ready? (Was fryer Ready before start?)	READY? YES

SECTION 4. LEVEL 1 PROGRAMMING







Level 1 contains the following:

- Modify product settings
- Set the AIF clock for products
- Perform the Deep Clean procedure
- Fryer Setup Mode

4-1. MODIFYING PRODUCT SETTINGS

1. Press and hold  and  buttons until LEVEL - 1 shows in the display, followed by ENTER CODE.
2. Enter code 1, 2, 3, 4 (first 4 product buttons). “PRODUCT” and “SELECTN” show in the displays.
3. Press right  button and ‘SELECT PRODUCT’ and “-P 1-” (ex: NUGGETS) show in the displays.

Change Product Names

4. Use the  and  buttons to scroll through the 40 products, or press the desired product button .
5. Press right  button and the product (ex: NUGGETS) shows in the left display and “MODIFY”, and “YES NO” shows in the right display. Press the  button to change this product, or press the **X** button to choose another product.
6. If  button was pressed, press and release a product button and the flashing letter changes to the first letter under the product button that was pressed. For example, if  is pressed, the flashing letter changes to an “A”.

Press the same button again and the flashing letter changes to a “B”. Press it again and the flashing letter changes to a “C”. Once the desired letter shows in the display, press  button to continue to the next letter and repeat the procedure.

Press and hold the right **X** button to exit Program Mode, or press  button to continue on to “1. COOK TIME”.

To Change Times and Temperatures

7. Press  button until “COOK TIME” shows in the display, and then use the product buttons  to change the time in minutes and seconds, to a maximum of 59:59.

4-1. MODIFYING PRODUCT SETTINGS (Continued)

- Press and release ▼ button and “TEMP” shows in display, along with preset temperature on the right side of the display.

Press the product buttons

1	2	3	4	5	6	7	8	9	0
ABC	DEF	GHI	JKL	MNO	PQR	STU	VWX	YZ	..*

 to change the temperature. The temperature range is 190°F (88°C) to 380°F (193°C).

Cook ID Change

- Press ▼ button until “COOK ID” shows in the display along with the product ID. For example, NUG would be the ID for nuggets. Use the product buttons to change the ID, following the same procedure as Step 6 above.

Alarms (Duty 1 & 2)

- Press ▼ button until “DUTY 1” shows in the left display, and an alarm time in the right display. Press the product buttons

1	2	3	4	5	6	7	8	9	0
ABC	DEF	GHI	JKL	MNO	PQR	STU	VWX	YZ	..*

 to set an alarm.

Ex., If a Cook Cycle was set at 3 minutes, and an alarm was to go off after 30 seconds into the Cook Cycle, “0:30” would be set in the display at this time. When the timer counts down to 2:30 the alarm sounds.

After the alarm time is set, press ▼ button and “DUTY 2” shows in the display, and a second alarm can be programmed.

Quality Timer

- Press ▼ button until QUAL TMR is displayed along with preset holding time. Press product buttons

1	2	3	4	5	6	7	8	9	0
ABC	DEF	GHI	JKL	MNO	PQR	STU	VWX	YZ	..*

 to adjust holding time, up to 2 hours, 59 minutes.

AIF Disable

- Press ▼ button until “AIF DISABLE” shows in the display along with “YES” or “NO”. Using ◀ and ▶ buttons change the display to “YES” if that product is to not be included in the automatic intermittent filtration operation, or “NO” if it is to be included.

Assign Button

- Press ▼ button until “ASSIGN BTN” shows in the display, along with the product (ex: NUGGETS). If this product already has a product button assigned to it, that LED will be lit. To assign other product buttons to that product, press and hold the product button for 3 seconds and that LED stays lit. To remove a product from a button, press and hold the product button with a lit LED and the LED goes out.



4-2. AIF CLOCK

This feature allows the controls to be set for periods of the day that block the automatic “Filter Now” prompts. For example, the controls could be set to not interrupt with “Filter Now” prompts during the lunch rush, and during the supper rush. But, if filtering is desired during this time, press and hold a  button to access the filter menu.

Each AIF Blocking period is defined by a start time (a time of day, XX:XX A, etc) and a duration in minutes.

Weekdays M-F are all grouped together. Up to four different AIF blocking periods may be programmed throughout the day for Monday - Friday. (All days share the same settings.)

A separate set of four blocking periods may be programmed for Saturdays, and a final set of four blocking periods may be programmed for Sundays.

1. Press and hold  and  buttons until LEVEL - 1 shows in the display, followed by ENTER CODE.
2. Enter code 1, 2, 3, 4 (first 4 product buttons). “PRODUCT” and “SELECTN” show in the displays.
3. Press ▼ button once and “AIF CLOCK” show in the displays.
4. Press ✓ button and use ◀ and ▶ buttons to scroll through “ENABLE” and “DISABLE” and then press ✓ button again to select one.
5. If “ENABLE” is chosen, then ▲ and ▼ buttons can be use to scroll through the following list of blocking periods:

Left Display	Right Display
M-F 1	XX:XX A XX
M-F 2	XX:XX A XX
M-F 3	XX:XX A XX
M-F 4	XX:XX A XX
SAT 1	XX:XX A XX
SAT 2	XX:XX A XX
SAT 3	XX:XX A XX
SAT 4	XX:XX A XX
SUN 1	XX:XX A XX
SUN 2	XX:XX A XX
SUN 3	XX:XX A XX
SUN 4	XX:XX A XX

4-2. AIF CLOCK
(Continued)

In 12-hour clock mode, there are three items on each line: the start time “XX:XX”, the A or P (am/pm) setting, and the “XX” duration. Use the ◀ and ▶ buttons to set these items, which flashes when the item is selected.

To set a new start time setting, use the product buttons



, to enter the new value.

Press the ▶ button to step over to the AM/PM setting. The A or P can be toggled by pressing the ‘0’ product button.

Press the ▶ button again to step over to the duration value (in minutes). Enter a new value using the product buttons,



NOTICE

In 24-hour clock mode, there are only two items on each line: the time (XX:XX) and the duration (XX). Again, the ◀ and ▶ buttons step you between these items.

Press the right-side X button to exit out of AIF Clock programming mode.



4-3. DEEP CLEAN MODE

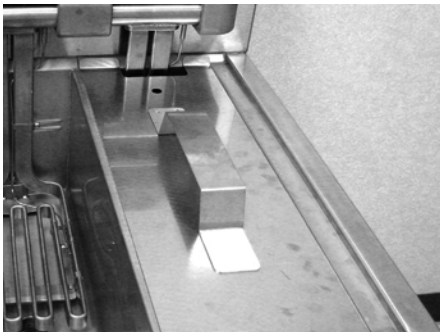



Put on protective gear: Be sure to use all McDonald’s approved safety equipment including, apron, face shield and gloves. Never begin Deep Clean process until you’re wearing all safety gear. Hot oil or water can cause severe burns.

1. Cover adjoining vats to avoid accidentally contaminating oil with fryer Deep Clean solution.

NOTICE

Do not cook product in an adjoining vat when the Deep Clean process is in progress to avoid contaminating the oil and product.

2. Press and hold  and  buttons until LEVEL - 1 shows in the display, followed by ENTER CODE.
3. Enter code 1, 2, 3, 4 (first 4 product buttons). “PRODUCT” and “SELECTN” show in the displays.
4. Press ▼ button twice and “DEEP CLEAN” shows in the displays. Press ✓ button and display shows “DEEP CLN?”, along with “YES NO”. Press ✓ button. **Full vat fryers, go on to step 6.**

4-3. DEEP CLEAN MODE
(Continued)

5. **Split vat fryers only!** Display shows “LEFT RIGHT”, asking you to select which vat will be cleaned. Press ✓ button to select left vat, or X button for the right vat.
6. Display shows “OIL RMVD” “YES NO”
7. If oil has already been removed, press ✓ button and control skips down to “Solution Added?” step.

If vat still has oil, press X button and display shows “DISPOSE” “YES NO”. Press ✓ button to dispose of the oil, or press X button to exit Deep Clean Mode. (If control suspects oil in drain pan “CAUTION IS THERE OIL IN PAN? YES NO” may show in display. Make sure drain pan is empty before proceeding)



JIB systems only! Display shows “IS DISPOSAL UNIT IN PLACE?” “YES NO”. If “NO” is selected, display shows “INSERT DISPOSAL UNIT”. Once disposal unit is in place press ✓ button for YES and display shows “DRAINING” and oil drains from vat.

Bulk systems only! Display shows “CHK PAN” if the filter drain pan is missing. Once pan is in place, display shows “DRAINING” and oil drains from vat. Once frypot is empty, open the door that has the RTI switch (at left) and press the “DISPOSE” button on the RTI switch until drain pan is empty.

Display then shows “VAT EMTY”, “YES NO”. Press ✓ button when ready.

8. Display shows “SOLUTION ADDED?” “YES NO”. Mix McD Heavy-Duty Degreaser Solution in the vat to be cleaned and fill vat to 1 in. (25 mm) above the top fill line. Then press ✓ button and display shows “START CLEAN” “YES NO”.
9. Press ✓ button display shows “CLEANING”, and a countdown timer. Heat regulates to 195°F (91°C) for this step for one hour.

NOTICE

Add water as needed during cleaning process to keep solution 1 in. (25 mm) above the top fill line.

To stop the cleaning cycle early, press X button. The display shows “QUIT DEEP CLN” “YES NO”. Press the ✓ button to cancel the rest of the countdown time and proceed to the rinse steps.

4-3. DEEP CLEAN MODE
(Continued)

10. Follow McDonald's vat cleaning procedure and at the end of the one hour, display shows "CLN DONE" and beeps. Press ✓ button and display then shows "REMOVE SOLUTION FROM VAT".
11. Empty filter drain pan of internal filtering components, take the components to a sink to be cleaned. Return the empty filter drain pan and cover to the fryer.
12. Using a 1/2 gal. (2 liter) pitcher, remove solution from vat, pouring it into a heat-resistant bucket for disposal. Any remaining solution can be drained into the drain pan for disposal, in step 14 below. Press ✓ button and display shows "VAT EMTY" "YES NO".



- **To avoid burns when pouring hot solution, wear gloves and protective gear and take care to avoid splashing.**
- **To avoid burns during operation, do not pump cleaning solution or water from drain pan into vat or oil lines.**

13. Once vat is empty, press ✓ button and display shows "SCRUB VAT COMPLETE" "YES NO". Use the Hi-Temp Detail Brush to clean heating elements and use the Hi-Temp Pad Holder and Pad to clean the inside of the vat walls, corners and top.



Do not scrape the electric fryer elements, or use the scouring pad on the elements. This produces scratches on the surface of the element causing breading to stick and burn.

Do not use steel wool, other abrasive cleaners, or cleaners/sanitizers containing chlorine, bromine, iodine, or ammonia chemicals as these will deteriorate the stainless steel material and shorten the life of the unit.

Do not use a water jet (pressure sprayer) to clean unit or component damage could result. Make sure the inside of the vat, the drain valve opening, and all the parts that will come in contact with the new oil are as dry as possible.



Use the lift tool and lift the hinged element from the vat as needed.

14. Once vat is clean, press the ✓ button and display shows "RINSE VAT" and the drain opens.

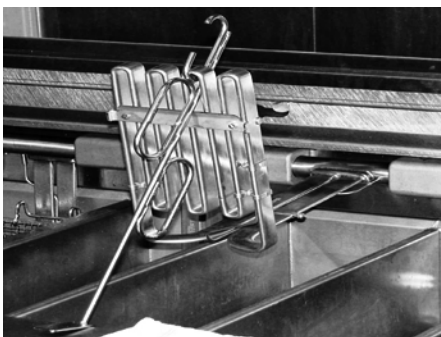

4-3. DEEP CLEAN MODE
(Continued)

15. Pour clean water into vat to rinse vat and allow rinse water to drain into drain pan. Rinse at least 3 times, but be careful not to overfill the drain pan. Display now shows “RINSE COMPLETE” “YES NO”.
16. Once vat is completely rinsed, press the ✓ button and display shows “CLEAR SOLUTION FROM OIL LINES” “✓ =PUMP” “X =DONE”

To make sure no cleaning solution remains in the oil lines, press and hold ✓ button for a few seconds. Once lines are clear, press X button and display shows VAT DRY?” “YES NO”.





To avoid burns, make sure all water and cleaning solution has been removed from the vat(s) and oil line(s).

17. Pull drain pan from under fryer and empty, using the 1/2 gal. (2 liter) pitcher and pouring it into a heat-resistant bucket for disposal.
18. Thoroughly dry the vat with a towel, and then press the ✓ button and controls return to normal operation.

See **Filling or Adding Oil Section** for refilling the vat.

4-4. FRYER SETUP

This mode has the same settings as seen upon initial start-up of the fryer. See Setup Mode, Section 3-3.

1. Press and hold  and  buttons until LEVEL - 1 shows in the display, followed by ENTER CODE.
2. Enter code 1, 2, 3, 4 (first 4 product buttons). “PRODUCT” and “SELECTN” show in the displays.
3. Press ▼ button 3 times and “FRYER SETUP” show in the displays.
4. Press ✓ button and *SETUP* *MODE* shows in the displays, followed by, “LANGUAGE” on the left display, “ENGLISH” on the right display.

Use ◀ or ▶ buttons to change the operation display to, “FRANCAIS”, “CAN FREN”, “ESPANOL”, “PORTUG”, “DEUTSCHE”, “SVENSKA”, “РУССКИЙ”.

Press ▼ to continue with the other set-up items which include:

- ZONE - USA, EUROPE or OTHER
- TEMP FORMAT - °F or °C
- TIME FORMAT - 12-HR OR 24-HR
- ENTER TIME - Time of day (use product buttons to change)
- ENTER TIME - AM OR PM
- DATE FORMAT - US OR INTERNATIONAL
- ENTER DATE - Today’s date (use product buttons to change)
- FRYER TYPE - GAS or ELEC
- VAT TYPE - FULL OR SPLIT
- BULK OIL DISPOSE - 1.NO; 2.RTI; 3.OTHER
- BULK OIL SUPPLY - YES/NO (BULK has RTI system)
- DAYLIGHT SAVING TIME - 1.OFF; 2.US (2007 & after); 3.EURO; 4.FSA (US before 2007)







Unless otherwise indicated, use ◀ or ▶ to change settings.

SECTION 5. LEVEL 2 PROGRAMMING

Used to access the following:





- Advanced changes to product settings
- Error code log
- Password programming
- Alert Tone/Volume
- No. of cook cycles before filter is suggested
- Automatic filter time

5-1. ADVANCED PRODUCT SETTINGS

1. Press  and  hold and buttons until LEVEL - 2 shows in the display, followed by ENTER CODE.
2. Enter code 1, 2, 3, 4 (first 4 product buttons). “PROD” and “COMP” show in the displays.
3. Press right  button and ‘SELECT PRODUCT’ and “-P 1-” show in the displays.
4. Use the  and  buttons to scroll through the 40 products, or press the desired product button
5. Press right  button and the product (ex: NUGGETS) shows in the left display and “MODIFY” “YES NO” shows in the right display. Press the  button to change this product, or press the **X** button to choose another product.

>Load Compensation, Load Compensation Reference,

Full Heat, PC Factor<

6. If  button was pressed, “LD COMP” shows in the display along with the load compensation value. This automatically adjusts the time to account for the size and temperature of the cooking load. Press the product buttons  to change this value of 0 to 20.
7. Press  button until “LCMP REF” shows in the display along with the load compensation average temperature. (if load compensation is set to “OFF”, then “_ _ _” shows in display and setting cannot be programmed) This is the average cooking temperature for each product. The timer speeds up at temperatures above this setting and slows down at temperatures below this setting. Press the product buttons  to change this value.

5-1. ADVANCED PRODUCT SETTINGS (Continued)

8. Press ▼ button until “FULL HT” shows in the display along with the full heat value in seconds, which means the heat is on as soon as a timer button is pressed, for the programmed length of time. Press the product buttons to change this value of 0 to 90 seconds.
9. Press ▼ button until “PC FACTOR” shows in the display along with the proportional temperature, which helps to keep the oil from over-shooting the setpoint temperature. Press the product buttons to change this value of 0 to 50 degrees.

NOTICE

- Use ▲ button to go back to previous menu items.
- Press X button when finished with the current product, to return to the PRODUCT SELECTN step.
- Press X button a second time to exit PROD COMP mode.

5-2. E-LOG (error code log)



1. Press and hold and buttons until LEVEL - 2 shows in the display, followed by ENTER CODE.
2. Enter code 1, 2, 3, 4 (first 4 product buttons). “PROD” and “COMP” show in the displays.
3. Press ▼ button and “E-LOG” shows in the display.
4. Press right ✓ button and “A” plus the present date & time flashes on the display, along with *NOW*.”
5. Press ▼ and if an error was recorded, “B” and the date, time, and error code information shows in display. This is the latest error code that the controls recorded.
6. Press ▼ and the next latest error code information can be seen. Up to 10 error codes (B to K) can be stored in the E-Log Section.

NOTICE





Press and hold the right ✓ button to view a brief description of the error.

5-3. PASSWORD

The 4-digit passwords can be changed for access to Set-Up, Usage, Level 1, Level 2, & Get Mgr.)



1. Press and hold  and  buttons until LEVEL - 2 shows in the display, followed by ENTER CODE.
2. Enter code 1, 2, 3, 4 (first 4 product buttons). “PROD” and “COMP” show in the displays.
3. Press ▼ button twice and “PASSWORD” shows in the display.
4. Press right ✓ button and “SET UP” shows in display. The Set up password can be changed at this time, or press ▼ once to change the USAGE password, twice for LEVEL 1 password, 3 times for LEVEL 2 password, or 4 times for GET MGR password. And then, follow instructions below.
5. If the password for the Set Up Mode (for example) is to be changed, press right ✓ button and “MODIFY? “YES NO” shows in the display. Press right ✓ button to change the 4-digit password for the Set Up Mode, using the product buttons  .
6. Once new password is entered, “CONFIRM PASSWORD” shows in the display. Press ✓ button to confirm, or press X to choose another password.

5-4. ALERT TONE (and volume)

1. Press and hold  and  buttons until “LEVEL - 2” shows in the display, followed by “ENTER CODE”.
2. Enter code 1, 2, 3, 4 (first 4 product buttons). “PROD” and “COMP” show in the displays.
3. Press ▼ button 3 times and “ALERT TONE” shows in the display.
4. Press right ✓ button and “VOLUME” shows in the display, along with the volume value. Use the product buttons  to set the volume from 1 (softest) to 10 (loudest).
5. Once volume is set, press ✓ button and “TONE” shows in display, along with the tone value. Use the product buttons  to set the tone from 50 to 2000 Hz.
6. Press X to exit Alert Tone Mode.



5-5. FILTER AFTER

This is the number of cook cycles between filters.

1. Press and hold  and  buttons until LEVEL - 2 shows in the display, followed by ENTER CODE.
2. Enter code 1, 2, 3, 4 (first 4 product buttons). “PROD” and “COMP” show in the displays.
3. Press ▼ button 4 times and “FLTR AFTR” shows in the display, along with the filter after value. Use the product buttons  to set the number of cook cycles before the controls suggest filtering, 0 to 99.
4. Once set, press ✓ button to confirm.



5-6. FILTER TIME

This is the amount of time fryer sits idle until filter is suggested.

1. Press and hold  and  buttons until LEVEL - 2 shows in the display, followed by ENTER CODE.
2. Enter code 1, 2, 3, 4 (first 4 product buttons). “PROD” and “COMP” show in the displays.
3. Press ▼ button 5 times and “FLTR TIME” shows in the display, along with the idle time (hours:minutes). Use the product buttons  to set the time the fryer sits idle before the controls suggest filtering, 0 to 18:00 (18 hours).
4. Once set, press ✓ button to confirm.

SECTION 6. TROUBLESHOOTING

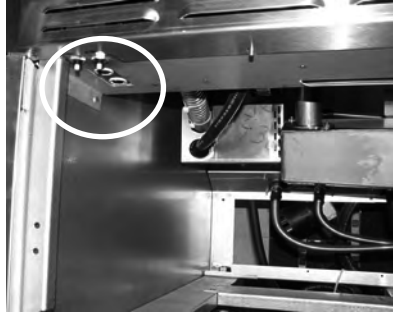
6-1. TROUBLE SHOOTING GUIDE

Problem	Cause	Correction
POWER switch ON but fryer completely inoperative	<ul style="list-style-type: none"> Open circuit 	<ul style="list-style-type: none"> Plug fryer in Check breaker or fuse at supply box (Non-US/some Int'l. locations only) Breakers in fryer tripped-open left door and reset breaker on fryer; See below 
Oil will not heat but lights are on No Heat error "E-22"	<ul style="list-style-type: none"> All power cords not plugged-in 	<ul style="list-style-type: none"> Unit has 2 power cords; make sure both are plugged-in; have heat circuit checked
Control error code "E-10"	<ul style="list-style-type: none"> Open high limit circuit 	<ul style="list-style-type: none"> Allow heating elements to cool (15-20 minutes) and reset high limit by pressing down and releasing raised side of the switch for the vat that is not operating; switches are located behind right door next to JIB.; if high limit does not reset, high limit must be replaced 
Vat is under-filled	<ul style="list-style-type: none"> JIB is low or empty JIB oil line is clogged or collapsed Filter pan needs cleaned 	<ul style="list-style-type: none"> Fill the JIB Check JIB line Clean filter pan and change paper or pad

**6-1. TROUBLE SHOOTING
GUIDE (Continued)**

Problem	Cause	Correction
Oil foaming or boiling over top of vat	<ul style="list-style-type: none"> • Water in oil • Improper or bad oil • Improper filtering • Improper rinsing after cleaning the vat 	<ul style="list-style-type: none"> • Drain and clean oil • Use recommended oil • Refer to filtering procedures • Clean and rinse vat and then dry thoroughly
Oil will not drain from vat	<ul style="list-style-type: none"> • Drain valve clogged with crumbs • Drain trough clogged 	<ul style="list-style-type: none"> • Open valve, use straight white brush to force crumbs through drain valve <div style="border: 2px solid black; padding: 5px; text-align: center; font-weight: bold; font-size: 1.2em;">NOTICE</div> <p>Do not leave brush in drain valve.</p> <ul style="list-style-type: none"> • Remove right side panel and remove plug from end of trough and clean trough
Filter motor runs but pumps oil slowly	<ul style="list-style-type: none"> • Filter line connections loose • Filter paper or pad clogged 	<ul style="list-style-type: none"> • Tighten all filter line connections • Change filter paper or pad
Bubbles in oil during entire filtering process	<ul style="list-style-type: none"> • Filter pan not completely engaged • Filter pan clogged • Damaged O-ring on filter line receiver on fryer 	<ul style="list-style-type: none"> • Make sure filter pan return line is pushed completely into the receiver on the fryer • Clean pan and change paper or pad • Change O-ring
Control error code “E-31”	<ul style="list-style-type: none"> • Elements are up 	<ul style="list-style-type: none"> • Lower elements back into vat
Filter motor will not run	<ul style="list-style-type: none"> • Power cord for vat #1 is not plugged-in • Open circuit • The thermal reset button on the rear of the pump motor is tripped 	<ul style="list-style-type: none"> • Plug power cord into receptacle • Breakers in fryer tripped-open left door and reset breaker on fryer • Allow time for the motor to cool; remove the JIB and then, using a screwdriver, press hard against the button until it clicks <div data-bbox="938 1556 1422 1906" style="text-align: center;"> </div>

6-2. ERROR CODES

In the event of a control system failure, the digital display shows an error message. The message codes are shown in the DISPLAY column below. A constant tone is heard when an error code is displayed, and to silence this tone, press any button.

DISPLAY	CAUSE	CORRECTION
“E-4”	Control board overheating	Turn switch to OFF position, then turn switch back to ON; if display shows “E-4”, the control board is getting too hot; check the louvers on each side of the unit for obstructions
“E-5”	Oil Overheating	Turn switch to OFF position, then turn switch back to ON; if display shows “E-5”, the heating circuits and temperature probe should be checked
“E-6A”	Temperature probe open	Turn switch to OFF position, then turn switch back to ON; if display shows “E-6A”, the temperature probe should be checked
“E-6B”	Temperature probe shorted	Turn switch to OFF position, then turn switch back to ON; if display shows “E-6B”, the temperature probe should be checked
“E-10”	High limit	Allow heating elements to cool (15-20 minutes) and reset high limit by pressing down and releasing raised side of the switch for the vat that is not operating; switches are located behind right door next to JIB.; if high limit does not reset, high limit must be replaced
“E-18-A” “E-18-B” “E-18-C”	Left level sensor open Right level sensor open Both level sensors open	Turn switch to OFF position, then turn switch back to ON; if display still indicates a failed sensor, have the connectors checked at the control board; have sensor checked & replace if necessary
“E-21”	Slow heat recovery	Have a certified service technician check the fryer for correct voltage to the unit; have the contactors and heating element checked; have unit checked for loose or burnt wires



6-2. ERROR CODES

DISPLAY	CAUSE	CORRECTION
“E-22”	Heat Error-No Heat	Check power cord and have heat circuit checked
“E-31”	Elements are up	Lower elements back into the vat
“E-41”, “E-46”	Programming failure	Turn switch to OFF, then back to ON; if display shows any of these error codes, have the controls re-initialized; if error code persists, have the control board replaced
“E-47”	Analog converter chip or 12 volt supply failure	Turn switch to OFF, then back to ON; if “E-47” persists, have the I/O board, or the PC board replaced
“E-48”	Input system error	Turn switch to OFF, then back to ON; have control PC board replaced if “E-48” persists
“E-54C”	Temperature input error	Turn switch to OFF, then back to ON; have control PC board replaced if “E-54C” persists
“E-60”	AIF PC board not communicating with control PC board	Turn switch to OFF, then back to ON; if “E-60” persists, have the 1.5 amp fuse on the AIF PC board checked; have the connector between the PC boards checked; replace AIF PC board or control PC board if necessary
“E-70C”	Drain valve jumper wire missing or disconnected	Have the jumper wire checked on the PC board at drain switch interlock position
“E-82A”	Selector Valve not detected	Have wiring checked between Selector Valve and AIF board
“E-82B”	Selector Valve Failed	Have the “Home” switch on Selector Valve checked
“E-82C”	Selector Valve Failed	Have wiring checked between the “Home” & “Position” switches and the Selector Valve; Have Selector Valve Motor checked; Have drive chain checked
“E-82D”	Selector Valve Failed	Have wiring checked between the “Home” & “Position” switches and the Selector Valve; Have Selector Valve Motor checked; Have drive chain checked

6-2. ERROR CODES (Continued)

DISPLAY	CAUSE	CORRECTION
“E-83”	E-83 Pressure Too High	Check power cord and have heat circuit checked
“E-83A”	Pressure too high Vat #1 during filtering	Have AIF system in Vat #1 checked
“E-83B”, “	Pressure too high Vat #2 during filtering	Have AIF system in Vat #2 checked
“E-83C”	Pressure too high Vat #3 during filtering	Have AIF system in Vat #3 checked
“E-83D”	Pressure too high Vat #4 during filtering	Have AIF system in Vat #4 checked
“E-83E”	Pressure too high Vat #5 during filtering	Have AIF system in Vat #5 checked
“E-83J”	RTI “JIB FILL” switch ON and pressure too high	Have JIB fill valves checked
“E-83R”	RTI “DISPOSE” switch ON and pressure too high	Check RTI quick-disconnect behind fryer; RTI phone no. if needed: 888-796-4997
“E-93A”	24VDC Tripped	Have motors for drain valves and selector valve checked



Henny Penny Corporation
P.O.Box 60
Eaton, OH 45320

1-937-456-8400
1-937-456-8402 Fax

Toll free in USA
1-800-417-8417
1-800-417-8434 Fax

www.hennypenny.com

Henny Penny Corp., Eaton, Ohio 45320, Revised 01/17/13

FM05-062-F