



OPERATOR'S M A N U A L

MULTIPURPOSE HOLDING CABINET

MODEL

MP-941

MP-942

MP-943

MP-944



HENNY PENNY
Engineered to Last

REGISTER WARRANTY ONLINE AT WWW.HENNYPENNY.COM

TABLE OF CONTENTS

Section	Page
Section 1. INTRODUCTION	1-1
1-1. Multipurpose Holding Cabinet	1-1
1-2. Features	1-1
1-3. Proper Care	1-1
1-4. Assistance	1-1
1-5. Safety	1-2
 Section 2. INSTALLATION	 2-1
2-1. Introduction	2-1
2-2. Unpacking.....	2-1
2-3. Electrical Requirements.....	2-2
2-4. Cabinet Dimensions.....	2-3
 Section 3. OPERATION	 3-1
3-1. Introduction	3-1
3-2. Operating Controls and Components	3-1
3-3. Start-Up	3-2
3-4. Operating With Product.....	3-3
3-5. Cleaning.....	3-3
3-6. Operation and Programming.....	3-4
3-7. Error Codes	3-6
 GLOSSARY	 G-1
 Distributor Lists – Domestic and International	

SECTION 1. INTRODUCTION

1-1. MULTIPURPOSE HOLDING CABINET

The Henny Penny Multipurpose Holding Cabinet is a basic unit of food equipment designed to hold hot foods at proper temperature in commercial food operations. This cabinet will keep hot foods humid while maintaining temperature.

NOTICE

As of August 16, 2005, the Waste Electrical and Electronic Equipment directive went into effect for the European Union. Our products have been evaluated to the WEEE directive. We have also reviewed our products to determine if they comply with the Restriction of Hazardous Substances directive (RoHS) and have redesigned our products as needed in order to comply. To continue compliance with these directives, this unit must not be disposed as unsorted municipal waste. For proper disposal, please contact your nearest Henny Penny distributor.



1-2. FEATURES

- Electronic heat control for each drawer
- Drawer accepts 4" steam table pans (1 full or, 2-1/2 size, or 3-1/3 size)
- Vented drawer fronts allow venting of excess humidity
- Easy access to all components for servicing
- High temperature gasket used for drawer seals
- Positive drawer closure to ensure good seal of compartment
- Easy to clean front drip edge for collection of excess moisture around drawers
- Solid stainless steel construction

1-3. PROPER CARE

As in any unit of food servicing equipment, the multipurpose holding cabinet does require care and maintenance. Requirements for the maintenance and cleaning are contained in this manual and must become a regular part of the operation of the unit at all times.

1-4. ASSISTANCE

Should you require outside assistance, just call your local Henny Penny distributor in your area, call Henny Penny Corp. at 1-800-417-8405 toll free or 1-937-456-8405, or visit Henny Penny online at www.hennypenny.com.

1-5. SAFETY

The only way to ensure safe operation of the Henny Penny Multipurpose Holding Cabinet is to fully understand the proper installation, operation and maintenance procedures. The instructions in this manual have been prepared to aid you in learning the proper procedures. Where information is of particular importance or is safety related, the words NOTICE, CAUTION, or WARNING are used. Their usage is described below:



SAFETY ALERT SYMBOL is used with DANGER, WARNING, or CAUTION which indicates a personal injury type hazard.



NOTICE is used to highlight especially important information.



CAUTION used without the safety alert symbol indicates a potentially hazardous situation which, if not avoided, may result in property damage.



CAUTION used with the safety alert symbol indicates a potentially hazardous situation which, if not avoided, may result in minor or moderate injury.



WARNING indicates a potentially hazardous situation which, if not avoided, could result in death or serious injury.

SECTION 2. INSTALLATION

2-1. INTRODUCTION

This section provides the installation instructions for the Henny Penny Multipurpose Holding Cabinet.

NOTICE

Installation of this unit should be performed by a qualified service technician.



Do not puncture the skin of unit with drills or screws as component damage or electrical shock could result.

2-2. UNPACKING

The Henny Penny Multipurpose Holding Cabinet has been tested, inspected, and expertly packed to ensure arrival at its destination in the best possible condition. The cabinet rests on cardboard pads that sit on a wooden skid. The unit is then packed inside a heavy cardboard carton with sufficient padding to withstand normal shipping treatment.

NOTICE

Any shipping damages should be noted in the presence of the delivery agent and signed prior to his or her departure.

To remove the unit from the carton, you should:

1. Carefully cut banding straps.
2. Lift carton off the unit.
3. Lift the unit from the cardboard pads and skid.



Take care when lifting unit to prevent personal injury. The units can weigh as much as 278 lbs. (126 kg).

2-2. UNPACKING (Continued)

4. Open drawers and remove the packing or literature that is inside.
5. Pull off any protective covering from the exterior of the cabinet.
6. Your multipurpose holding cabinet is now ready for location and setup.

2-3. ELECTRICAL

The multipurpose holding cabinets are available from the factory as 120 VAC for domestic use, or 230 VAC for international use. The units are single phase and require a grounded (earthed) receptacle with a separate electrical line protected by a fuse or circuit breaker of the proper rating.



The electrical plugs for the 230 volt units must be supplied by the distributor and have the proper grounding (earthing).

DATA TABLE:

Model Number	Volts	Phase	Watts	Amps
MP-941	120	1	475	3
MP-942	120	1	950	6
MP-943	120	1	1425	9
MP-944	120	1	1900	12
MP-941	230	1	475	2
MP-942	230	1	950	4
MP-943	230	1	1425	6
MP-944	230	1	1900	8



To avoid electrical shock, the cabinet must be adequately and safely grounded (earthed) according to local electrical codes.

(FOR EQUIPMENT WITH CE MARK ONLY!)

To prevent electric shock hazard this appliance must be bonded to other appliances or touchable metal surfaces in close proximity to this appliance with an equipotential bonding conductor. This appliance is equipped with an equipotential lug for this purpose. The equipotential lug is marked with the following symbol



After the multipurpose holding cabinet has been set into position and leveled, run a bead of silicone rubber (silicone or equivalent sealant must be a NSF listed material) around the perimeter of the unit sealing it to the surface. You are now ready to make the electrical connections to the unit.

2-2

208

2-4. CABINET DIMENSIONS

MP-941

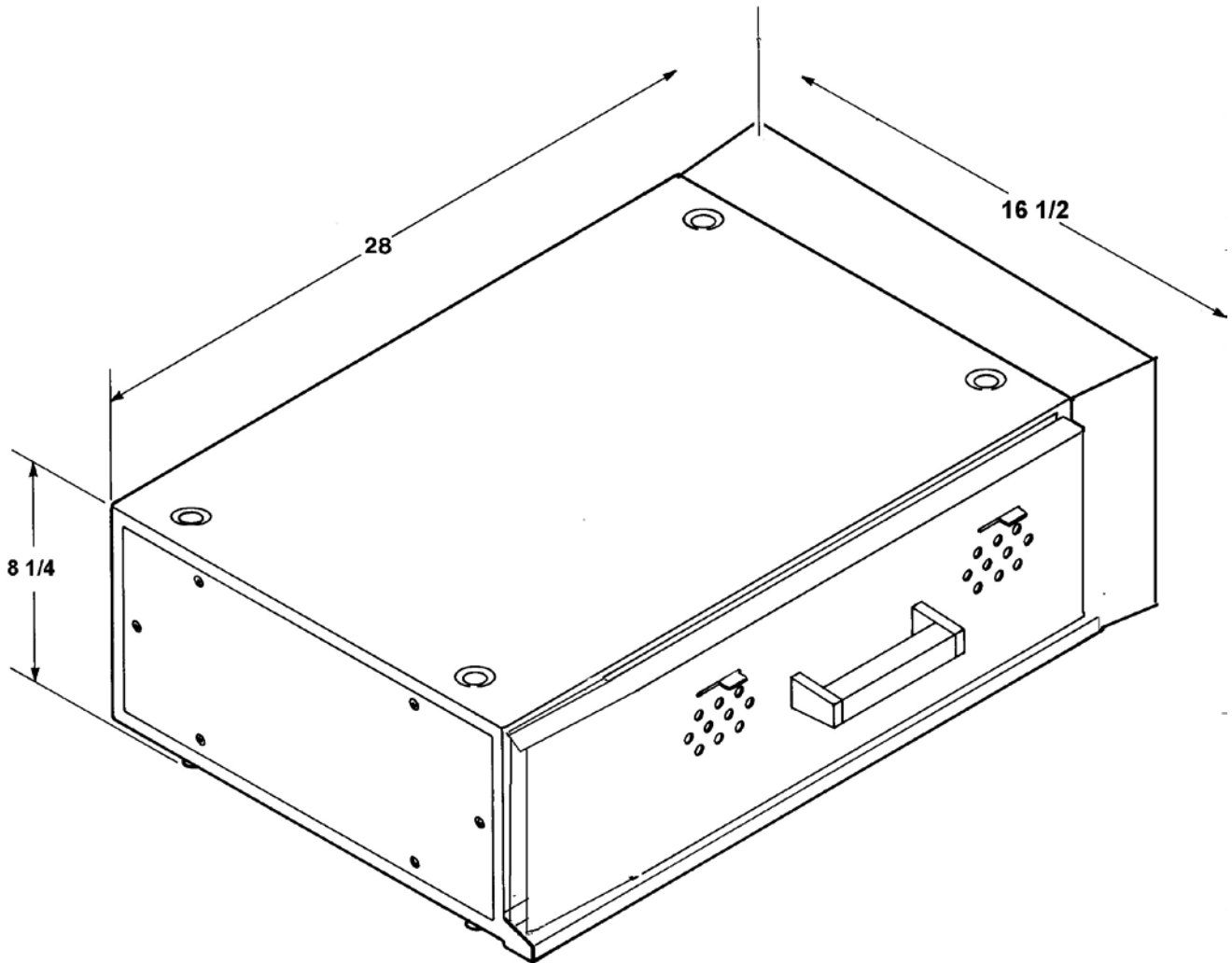

2-4. CABINET DIMENSIONS
(Continued)

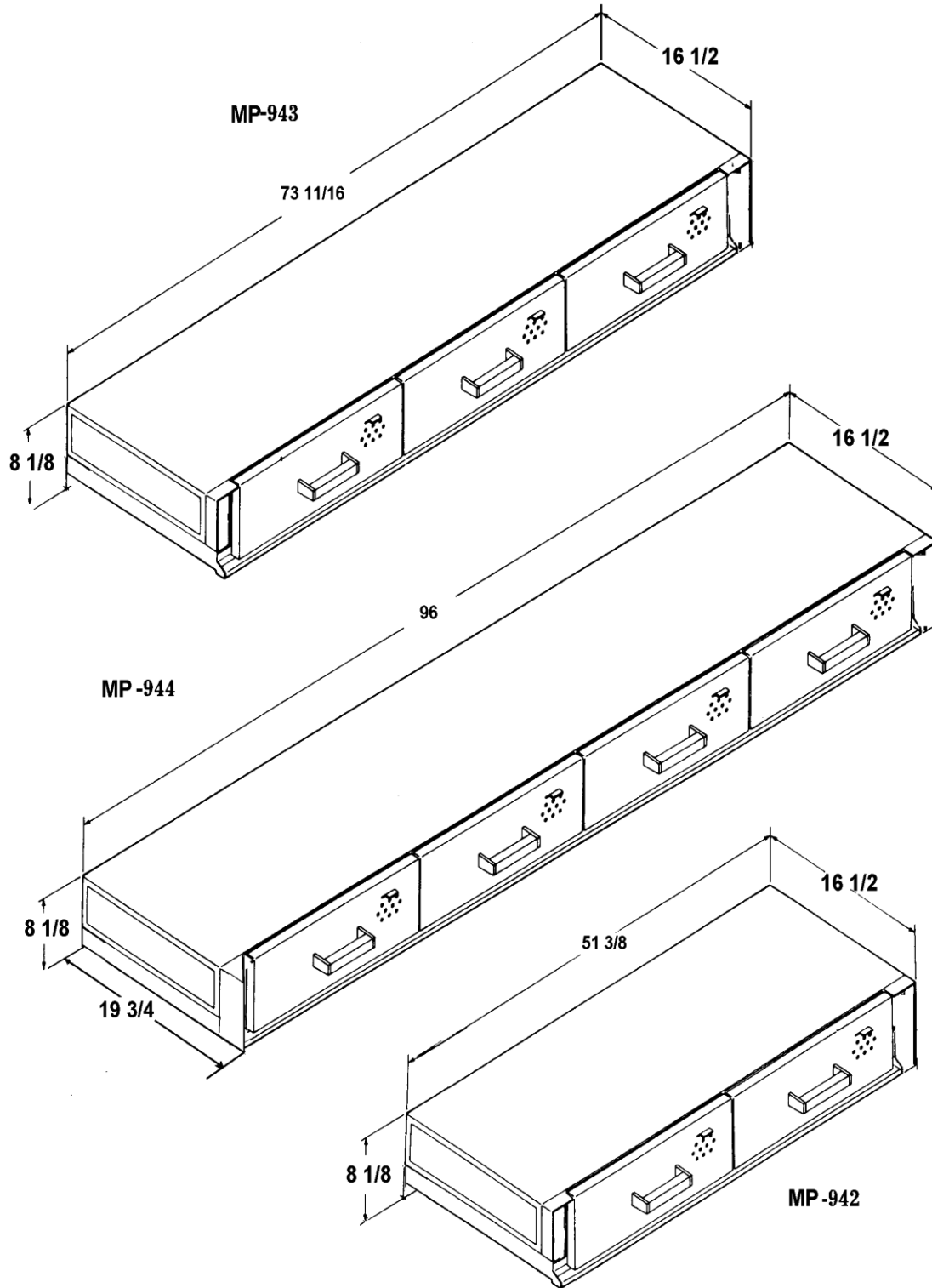

SECTION 3. OPERATION

3-1. INTRODUCTION

This section provides operating procedures for the multipurpose holding cabinets. Read the Introduction, Installation and Operation Sections, and all instructions should be followed before operating the cabinet.

This section contains an explanation of all controls, components, and information on operating procedures and daily maintenance.

3-2. OPERATING CONTROLS AND COMPONENTS

Figure 3-1 identifies and describes the functions of all the operating controls and components of the cabinet.

Item No.	Description	Function
1	Digital Display	An LED display which shows the time of day and drawer temperature
2	LEDs	When illuminated, setpoint temperature has been reached
3	UP and DOWN Buttons	Used when programming the controls, changing the display, and accessing the Special Program Mode
4	POWER Switch	A rocker switch that controls the power to the unit
5	Drawer TEMP Buttons	Used to view the drawer temperature, and to set the setpoint temperature for the drawer
6	SET Button	Used in the Program Mode

1210

3-1

**3-2. OPERATING
CONTROLS AND
COMPONENTS (Continued)**

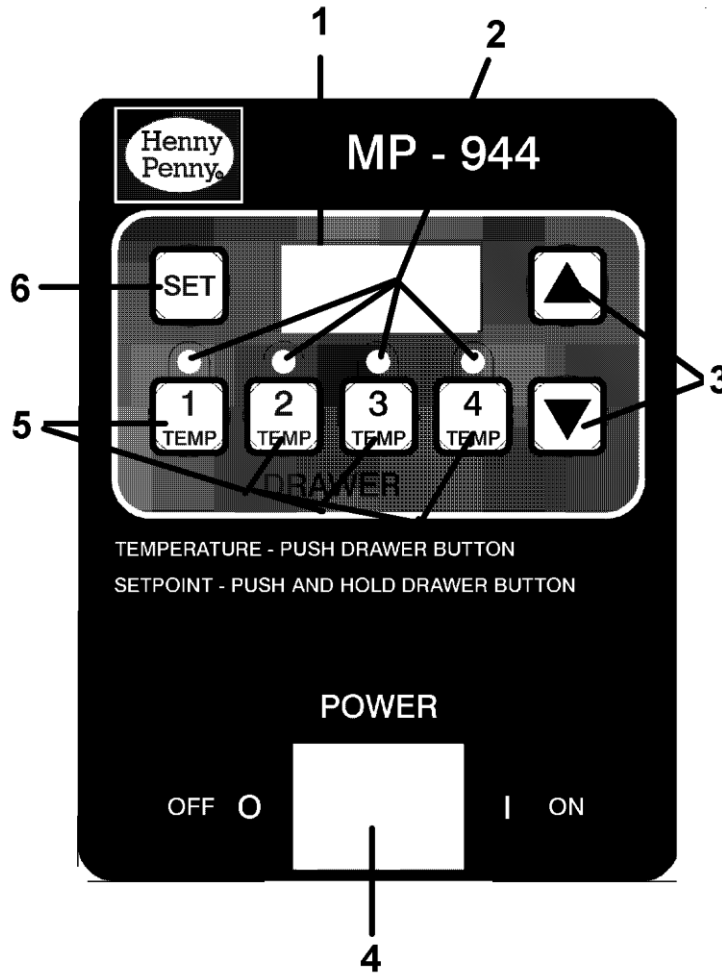

Figure 3-1

3-3. START-UP

NOTICE

Before using the cabinet, it should be thoroughly cleaned as described in the cleaning procedures section of this manual. To put the cabinet into operation, move each POWER switch to the ON position and adjust each control to the appropriate temperature. The power light should illuminate indicating that the unit is operating. The operating temperature of this unit should be achieved in approximately 30 minutes.

3-2

3-3. START-UP (Continued)

103

1. Turn the POWER switch to the ON position.
2. The display will show the time of day or “ON”.

NOTICE

Press and hold the appropriate drawer button to view the actual temperature of the drawer.

3. When the temperature LED illuminates, the setpoint temperature has been reached and product can now be loaded into the drawer.

3-4. OPERATING WITH PRODUCT

1. Place the hot product inside one of the drawers.
2. Serve the product first that has been in the cabinet the longest.
3. Open the drawers only as necessary to load and serve the product.

3-5. CLEANING

1. Move the POWER switch to the OFF position.
2. Disconnect the electrical supply to the unit.



To avoid burns, allow the unit to cool before cleaning by opening all the drawers fully for approximately 20 minutes.

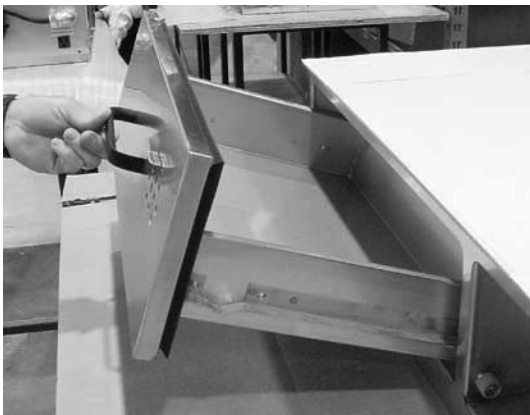

Step 3

3. Remove the drawers by pulling straight out and tilting up.
4. Clean drawers with a cloth and soapy water.

3-5. CLEANING (Continued)

5. Clean the interior of the cabinet thoroughly with a cloth and soapy water.

CAUTION

Do not use steel wool, other abrasive cleaners or cleaners/sanitizers containing chlorine, bromine, iodine or ammonia chemicals, as these will deteriorate the stainless steel material and shorten the life of the unit.

Do not spray the unit with water, such as, with a garden hose. Failure to follow this caution could cause component failure.

6. Wipe down the exterior of the cabinet with a damp cloth. Avoid getting water in the area of the control panel.
7. Replace the drawers.
8. If the unit is to be left off, leave the drawers open two or three inches.

3-6. OPERATION AND PROGRAMMING

Unit Operation

1. Turn POWER switch to the ON position.
2. The display will show the time of day, or "ON".

NOTICE

Press and hold any of the drawer buttons to view the actual temperature of the drawer.

Time of Day Programming

Press and hold the SET button while using the UP and DOWN buttons to set the desired time. When the SET button is released the time will be saved.

Temperature Setpoint Programming

1. Press and hold the appropriate drawer button for 6 seconds. The actual temperature will be shown first followed by the flashing setpoint temperature.

3-4

203

3-6. OPERATION AND PROGRAMMING
(Continued)

2. While holding in on the drawer button, press and release the SET button. Now the setpoint temperature will be blinking at a faster rate. Now release the drawer button.
3. Press the UP and DOWN buttons to change the setpoint temperature.
4. Once the desired setpoint temperature is reached, press the SET button to return to normal operation mode and the setpoint will be saved.

Special Program Mode

1. Turn the POWER switch off. Press and hold both the UP and DOWN buttons and turn the POWER switch back on. Press and hold the UP and DOWN buttons until "SP" shows on the display, then release the UP and DOWN buttons. Display will now show "°F" or "°C".
2. Press the UP or DOWN buttons to toggle from "°C" (Celsius), or "°F" (Fahrenheit).
3. Press and release the SET button, and display will show "CAL". Press and hold the button of the drawer to be calibrated, and use the UP and DOWN buttons to match the display to the actual temperature.
4. After the calibration mode, press and release the SET button to access Initialization Mode.
5. Press and hold either the UP or DOWN button until display reads "In- SYS". This resets all setpoint temperatures to 180 °F (82° C).
6. After the initialization mode, press and release the SET button the access the Output Test Mode.
7. "OP" will show in the display. Press and release any of the drawer buttons to turn the relays and heaters off and on.
8. After the output test mode, press and release the SET button to access the Display Mode.
9. If "C=y" shows in the display, the time of day shows in the display during normal operation. If "C=n" shows in the display, "ON" shows on the display during normal operation. Press and release the UP and DOWN buttons to toggle from "y" to "n" or vice versa.
10. Press and hold the set button to exit Special Program Mode at any time.

3-6. OPERATION AND PROGRAMMING (Continued)

Setting Control to the Correct Number of Drawers

The different models, MP-941, 942, 943, and 944, all use the same control board. The boards are programmed at the factory for the correct unit. But, should the unit show “E06” or some drawers will not heat, the board may not be programmed for the appropriate unit.



The LED flashes at a fast rate for the drawer(s) not programmed correctly.

To check the drawer programming, turn the unit off, then back on. The display will flash the number of drawers the unit is programmed for. If the unit is not programmed correctly, follow these steps:

1. Turn the power switch off, then press and hold the SET button and the drawer button, which corresponds to the number of drawers that the unit has, and turn unit back on, ex: MP-944=SET and number 4 button.
2. Release the buttons, and now the unit should be set up for use.



Pressing and holding the drawer button shows the temperature of that drawer. If no temperature is displayed, the unit may need to be programmed by the above steps.

3-7. ERROR CODES

DISPLAY	CAUSE	PANEL BOARD CORRECTION
“E-4”	Control board overheating	Turn switch to OFF position, then turn switch back to ON; if display shows “E-4,” the control board is getting too hot; make sure unit is not overheating
“E-6”	Faulty temperature probe	Check to see if unit is set to the correct number of drawers, ex: MP-942=2 drawers (see programming instructions)
“E-41”	Memory scrambled	Press and release the UP and DOWN buttons to initialize the program; if “E-41” persists replace the control board
“Hi”	Unit overheating; faulty relay or control board	Have relay or control board replaced

GLOSSARY
HENNY PENNY HOLDING CABINETS

air temperature probe	a round device located inside the cabinet that measures the inside air temperature and sends that information to the control panel
concentration ring assembly	a metal assembly located in the water pan in the bottom of the unit that helps keep an even humidity level inside the cabinet
clean water pan setpoint	a preset temperature at which a sensor warns the operator that the water pan has excessive lime deposits
control panel	the components that control the operating systems of the unit; the panel is located on the top, front surface of the cabinet
deliming agent	a cleaner used to remove lime deposits in the water pan
drain valve	a device that lets the water drain from the water pan into a shallow pan on the floor; the valve should be closed while the unit is in use if humidity is desired
float switch	a device that senses low water levels in the water pan
food probe	a sensor located outside the cabinet that, when inserted into the product, communicates the temperature of the product to the control panel
food probe receptacle	the connection where the food probe is inserted in order to communicate with the control panel
humidity sensor	a device that measures the percentage of humidity inside the cabinet during use
humidity setting	a preset moisture level at which the cabinet operates; this setting is programmed at the factory but can be changed in the field
LED	an electronic light on the control panel
minimum holding temperature	the lowest temperature at which a food product can be safely held for human consumption
module	the removable top part of the cabinet that contains all of the operating system
out of water trip point	a preset temperature at which a sensor warns the operator that the water pan needs refilled
parameters	a preset group of setpoints designed for holding specific food products at certain temperature and humidity levels
power switch	the ON/OFF switch that sends electricity to the unit's operating systems; this switch does not disconnect the electrical power from the wall to the unit
pressure sprayer	a device that shoots a stream of water under pressure; this device should NOT be used to clean a holding cabinet

103

G-1

probe clip	a metal holder that attaches to the outside of the control panel to hold the food probe when not in use; the clip is an optional accessory
product load capacity	the highest recommended number of pounds/kilograms of food product that can be safely held in the cabinet
proof function	a program used for allowing bread to rise
relative humidity	the humidity level outside the cabinet
setpoint	a preset temperature or humidity; the setpoint is a programmable feature
system initialization	a programming process that resets factory settings
temperature setting	a preset temperature up to which the cabinet will heat; this setting is programmed at the factory but can be changed in the field
vent activation switch	an automatic control that opens and closes the vent on the rear of the cabinet to maintain the preset humidity level
vented panels	openings on the cabinet that allow air access on the sides and rear of the module
water fill line	the line marked on the inside of the water pan that shows the maximum water level to prevent overflow onto the floor
water heater sensor	a part in the water heater that sends a message to the controls when the water pan is limed up or empty
water jet	a device that shoots a stream of water under pressure; this type of device should NOT be used to clean a holding cabinet
water pan	the area in the cabinet that holds water for creating humidity inside the cabinet



Henny Penny Corporation
P.O.Box 60
Eaton, OH 45320

1-937-456-8400
1-937-456-8402 Fax

Toll free in USA
1-800-417-8417
1-800-417-8434 Fax

www.hennypenny.com