

SECTION 3. PARTS INFORMATION

3-1. INTRODUCTION

This section lists the replaceable parts of the Henny Penny OFE-321 & 322 Open Fryers.

3-2. GENUINE PARTS

Use only genuine Henny Penny parts in your fryer. Using a part of lesser quality or substitute design may result in damage to the unit or personal injury.

3-3. WHEN ORDERING PARTS

Once the parts that you want to order have been found in the parts list, write down the following information:

Item Number	<u>8</u>	Example:
Part Number	<u>31561</u>	
Description	<u>On/Off Switch</u>	

From the data plate, list the following information:

Product Number	<u>01400</u>	Example:
Serial Number	<u>0001</u>	
Voltage	<u>208</u>	

3-4 PRICES

Your distributor has a price parts list and will be glad to inform you of the cost of your parts order.

3-5 DELIVERY

Commonly replaced items are stocked by your distributor and will be sent to you when your order is received. Other parts will be ordered, by your distributor, from Henny Penny Corporation. Normally, these will be sent to your distributor within three working days.

3-6 WARRANTY

All replacement parts (except lamps and fuses) are warranted for 90 days against manufacturing defects and workmanship. If damage occurs during shipping, notify the carrier at once so that a claim may be properly filed. Refer to warranty in the front of this manual for other rights and limitations.

3-7. RECOMMENDED SPARE PARTS FOR DISTRIBUTORS

Recommended replacement parts, stocked by your distributor, are indicated with √ in the parts lists. Please use care when ordering recommended parts, because all voltages and variations are marked. Distributors should order parts based upon common voltages and equipment sold in their territory.

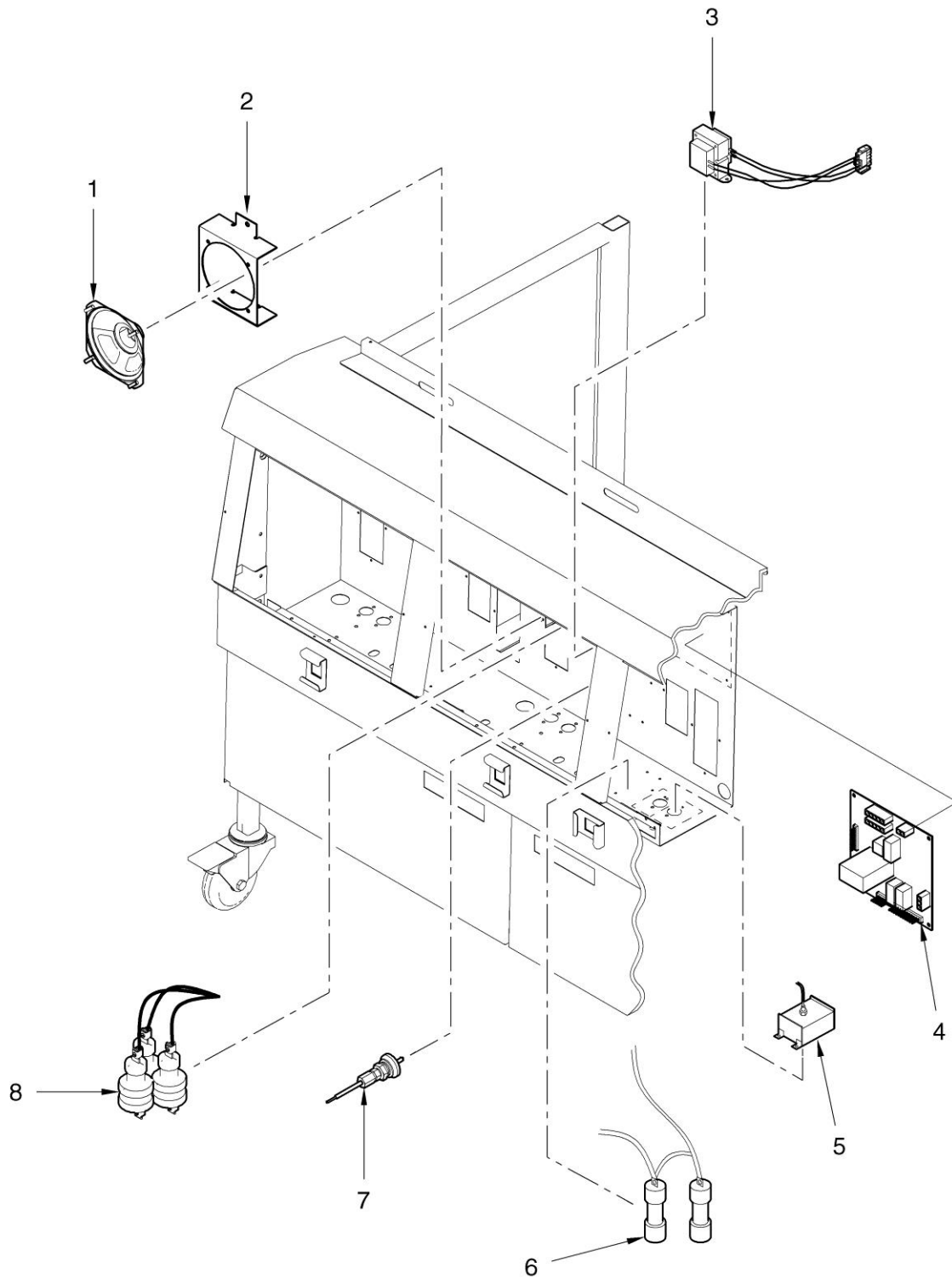

Figure 3-1. Electric Heat Controls

FIGURE & PART NO. ITEM NO.	DESCRIPTION	QTY. PER UNIT	
		321	322
3-1	ELECTRIC HEAT CONTROLS		
√ 1	26863 SPEAKER ASSY	1	2
√ 2	24916 SPEAKER BRACKET ASSY.	1	2
√ 3	60536 24V/230V TRANSFORMER ASSY.	1	2
√ 4	27286RB I/O BOARD ASSY.	1	2
√ 5	60241 425° HIGH LIMIT ASSY.	1	2
√ 6	EF02-006 20A 250V FUSE HOLDER	2	4
√ 6	EF02-007 15 AMP FUSE (SN: BA0608031 & below)	2	4
√ 6	EF02-125 BREAKER-PUSH BUTTON RESET (SN: BA0608032 & after)	2	4
√ 7	14990 KIT – ELECTRIC TEMP PROBE	1	2
√ 8	29509 KIT–E/M 24V CONTACTOR–PRIMARY	1	2
√ 8	29510 24V MERCURY CONTACTOR (SN: BA08010019 & BEFORE)	1	2
√ 8	65073 CONTACTOR – E/M (SN: BA08010020 & AFTER)	1	2
9*	60810 I/O BOARD TO CONTROL CABLE - 4 PIN	1	2
10*	60838 TRANSFORMER -480V TO 240V - OFE-322	-	2
11*	60847 TRANSFORMER MOUNTING BRACKET	-	2
12*	19923 TRANSFORMER-LARGE--480V-240V - OFE-321	1	-
√ 13*	60722 BLOCK – 60 AMP FUSE (208-240V FRYERS)	1	2
√ 14*	14970 KIT-60 AMP FUSE - SET OF 3 (208-240V FRYERS)	1	2
√ 15*	24347 ASSEMBLY – CURRENT SENSE XFORMERS	1	2
√ 16*	27290 ASSEMBLY – CURRENT SENSE PCB	1	2

√ recommended parts

*not shown

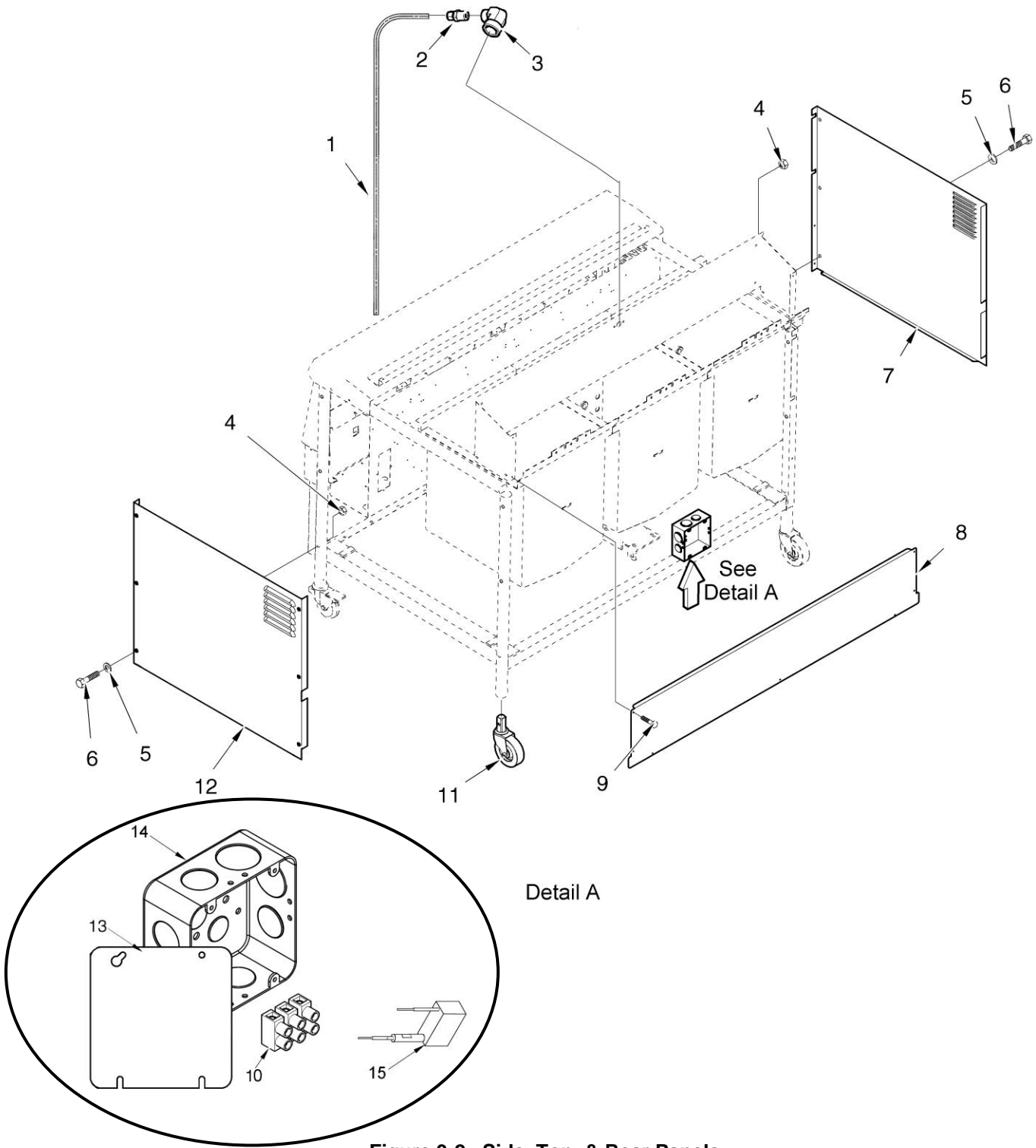

Figure 3-2. Side, Top, & Rear Panels

FIGURE & ITEM NO.	PART NO.	DESCRIPTION	QTY. PER UNIT	
			321	322
3-2		SIDE, TOP, AND REAR PANELS		
1	26901	TUBE, OIL RETURN LINE – OFE-322 (before 12-1-06)	-	1
1	73957	TUBE, OIL RETURN LINE – OFE-322 (after 12-1-06)	-	1
2	FP01-082	CONNECTOR - 3/8 TUBE TO ½ NPT SS– OFE-322	-	2
3	FP01-087	ELBOW– OFE-322	-	1
4	NS02-002	NUT, END PANEL RETAINING	6	6
5	WA01-002	FLAT WASHER	6	6
6	SC01-216	SCREW	6	6
7	60552	SIDE PANEL, RH	1	1
8	59042	TOP REAR COVER (2 WELL)	-	1
8	59043	TOP REAR COVER (1 WELL)	1	-
9	SC03-005	SCREW, BOX RETAINING	2	2
10	63097	TERMINAL BLOCK – 2 POLE	1	1
11	60312	CASTER 4 IN. W/O BRAKE	2	2
12	60551	SIDE PANEL, LH	1	1
13	26877	COVER – JUNCTION BOX – 32X - CFA	1	1
14	26876	BOX – JUNCTION – 32X – CFA	1	1
15	36012	ASSY – CAPACITOR/RESISTOR	1	1

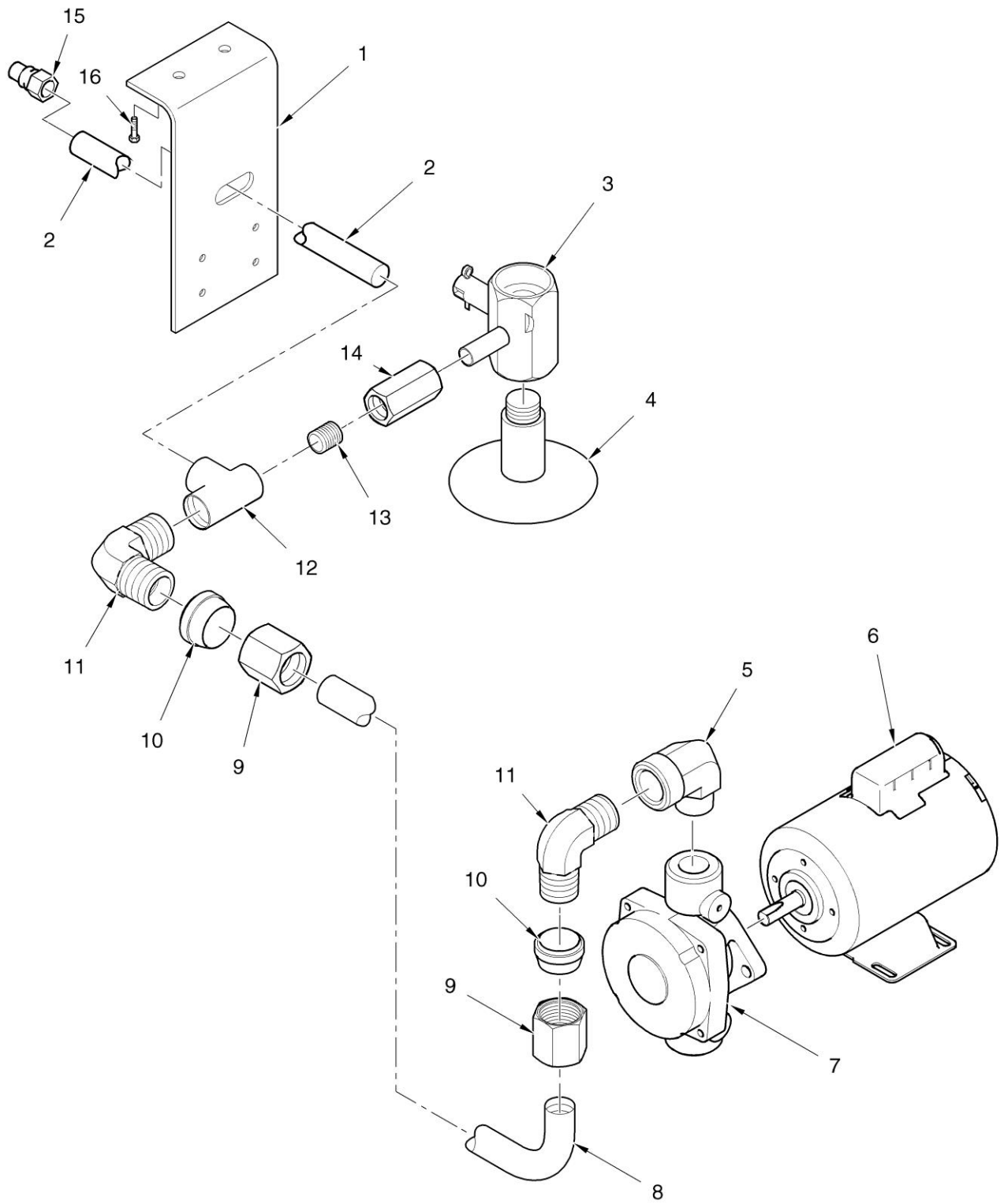

Figure 3-3. Oil Filtering System

FIGURE & ITEM NO.	PART NO.	DESCRIPTION	QTY. PER UNIT	
			321	322
3-3		OIL FILTERING SYSTEM		
1	66005	FRONT PLATE	1	-
2	17320	PIPE, FRONT	1	-
3	55152	DRAIN VALVE & COUPLING ASSY.	1	2
4	60736	DRAIN VALVE EXT. (ELECT.) (SN: GM024JB & BELOW)	1	2
4	24643	DRAIN VALVE EXT. (ELECT.) (SN: GM025JB & ABOVE)	1	2
5	16239	ELBOW, FILTER PUMP	1	-
6	67589	ASSY – FILTER PUMP & MOTOR	1	1
6	67583	FILTER PUMP MOTOR, 1/2 HP	1	1
7	17437	FILTER PUMP	1	1
8	26966	ASSY – POT TO PUMP TUBE – OFE-321	1	-
9	16809	NUT, FILTER TO VALVE TUBE	2	-
10	16808	FERRULE, FILTER TO VALVE TUBE	2	-
11	17407	ELBOW, FILTER PUMP TUBE	1	-
12	17306	TEE	1	-
13	50715	NIPPLE	1	-
14	17308	VALVE, FILTER	1	-
15	17334	QUICK CONNECT FITTING	1	-
16	SC03-005	SCREW, PLATE RETAINING	2	-

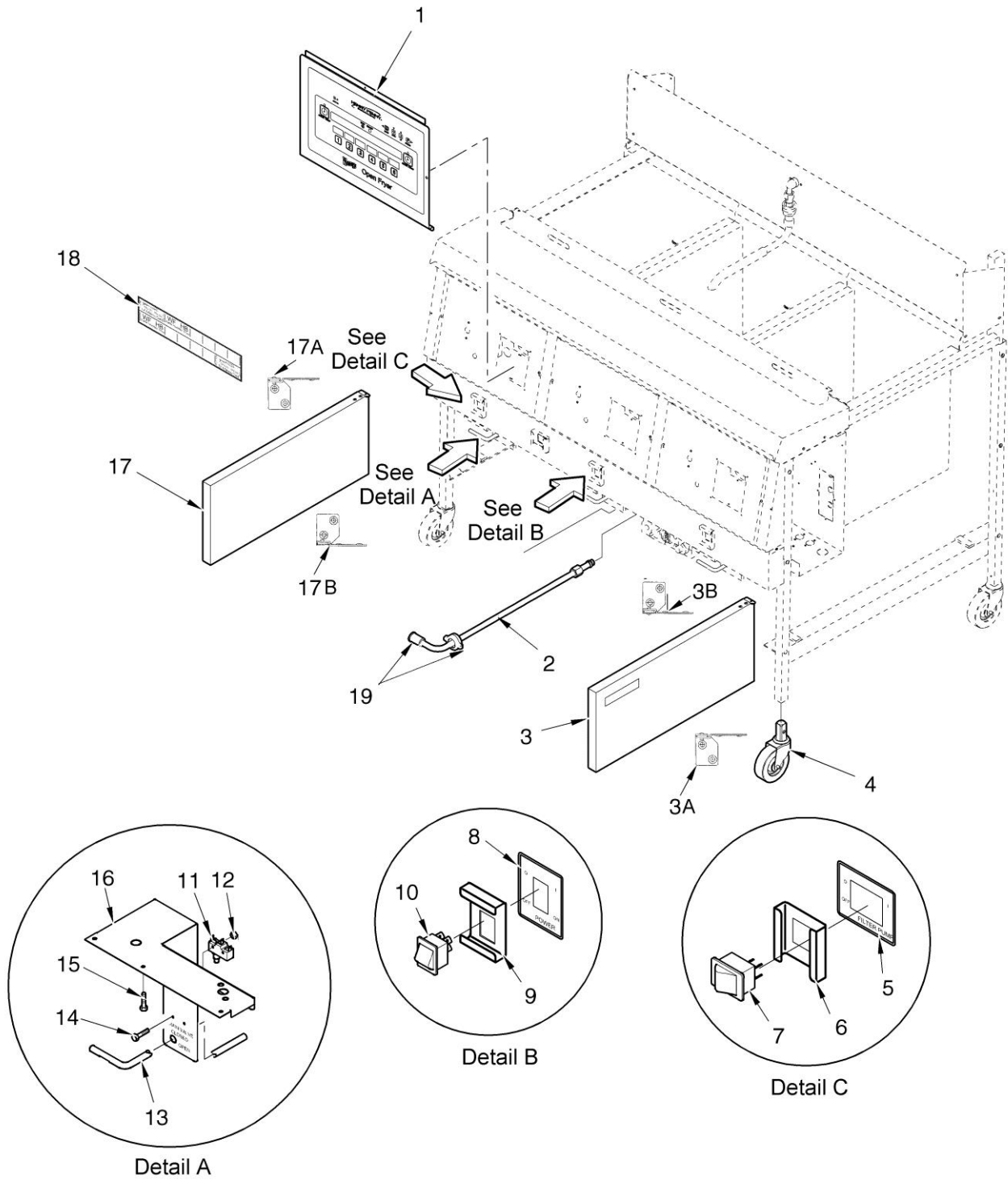

Figure 3-4. Door, Switches, Menu Card, & Control Board

FIGURE & ITEM NO.	PART NO.	DESCRIPTION	QTY. PER UNIT	
			321	322
3-4		DOOR, SWITCHES, MENU CARD, & CONTROL BOARD		
√ 1	67924RB	12 TIMER CONTROL BOARD ASSY.	1	2
2	60442	FILTER TO PUMP TUBE ASSY.	1	1
3	71874	RIGHT DOOR ASSY. (2 WELL) (SN: BA0604017 & above)	-	1
3	60501	RIGHT DOOR ASSY. (2 WELL) (SN: BA0604016 & below)	-	1
3A	17618	HINGE – DOOR – TOP	-	1
3B	17620	HINGE – DOOR – BOTTOM	-	1
4	52064	4 IN. SWIVEL CASTER W/ BRAKE	2	2
5	60609	DECAL, FILTER POWER SWITCH	1	1
6	60844	SWITCH GUARD, FILTER SWITCH	1	1
√ 7	43768	FILTER SWITCH	1	1
8	60608	DECAL, MAIN POWER SWITCH (321-SN: BA0604010 & below; 322-SN: BA0604001 & below)	1	2
8	72677	DECAL, MAIN POWER SWITCH (321-SN: BA0604011 & above; 322-SN: BA0604002 & above)	1	2
9	60844	SWITCH GUARD, POWER SWITCH	1	2
√ 10	72277	POWER SWITCH ASSY.	1	2
√ 11	18227	DRAIN MICROSWITCH	1	2
11	14681	KIT – OFE-321 N/O DRAIN SWITCH-CONVERSION	1	-
11	14651	KIT – OFE-322 N/O DRAIN SWITCH-CONVERSION	-	1
12	NS02-005	NUT	2	4
13	18818	DRAIN VALVE EXTENSION ROD	1	2
13	74193	ROD – N/O 320 DRAIN	1	2
14	SC01-058	SCREWS, COVER & BRACKET RETAINING (6-32 X 1.5 IN.)	2	4
15	SC03-005	SCREWS, BRACKET RETAINING	2	4
16	60718	DRAIN SWITCH BRACKET (OFE-322)	-	2
16	24802	DRAIN SWITCH BRACKET (OFE-321)	1	-
17	71875	LEFT DOOR ASSY. (2 WELL) (SN: BA0604017 & above)	-	1
17	60502	LEFT DOOR ASSY. (2 WELL) (SN: BA0604016 & below)	-	1
17	71870	DOOR ASSY. (1 WELL) (SN: BA0604017 & above)	1	-
17	60542	DOOR ASSY. (1 WELL) (SN: BA0604016 & below)	1	-
17A	17618	HINGE – DOOR – TOP	1	1
17B	17620	HINGE – DOOR – BOTTOM	1	1
18	61724	CFA MENU CARD	1	2
√ 19	69289	ASSY – FILTER UNION	1	1
20*	18911	FILTER VALVE HANDLE (OFE-321)	1	-
21*	17002	DOOR MAGNET	1	2
22*	60503	BRKT – MAGNET	1	2
23*	SC03-005	SCREWS	2	4

√ recommended parts

*not shown

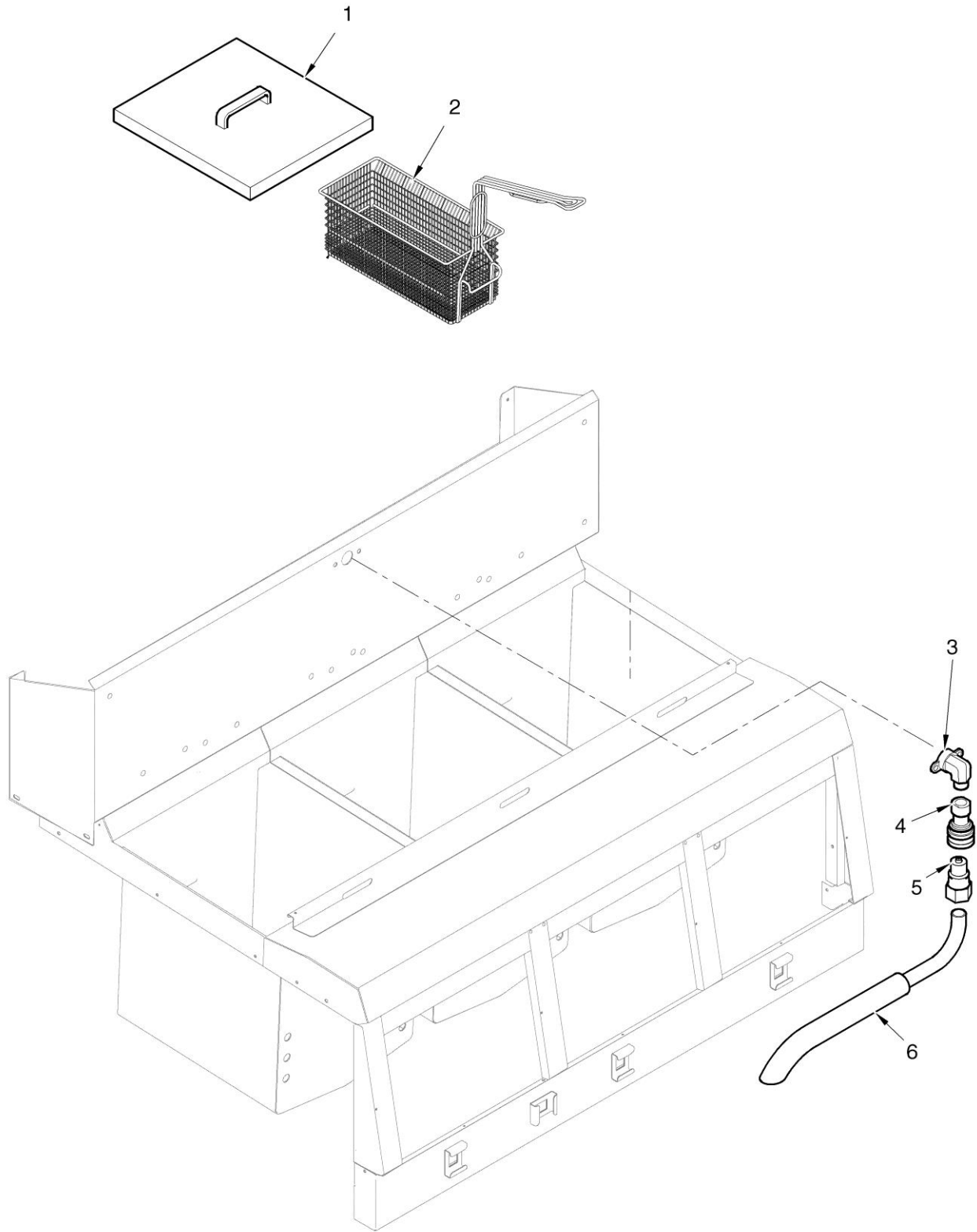

Figure 3-5. Baskets and Return Faucet

FIGURE & ITEM NO.	PART NO.	DESCRIPTION	QTY. PER UNIT	
			321	322
3-5		BASKETS AND RETURN FAUCET		
1	26873	FRYPOT COVER	1	2
2	21033	HALF SIZE BASKET	2	4
2	69085	HALF SIZE BASKET – FRONT & REAR HOOK	2	4
3	FP01-087	ELBOW, MALE, 3/8 IN.	1	1
4	17333	FEMALE DISCONNECT	1	1
5	17334	MALE DISCONNECT	1	1
6	70560	ASSY-RETURN FAUCET W/MALE DISCONNECT-322	-	1
7*	140124	KIT-321CFA-BSKT REST REINFRMT	1	PER VAT
8*	140136	KIT-321CFA-BSKT REST REINF	1	PER VAT

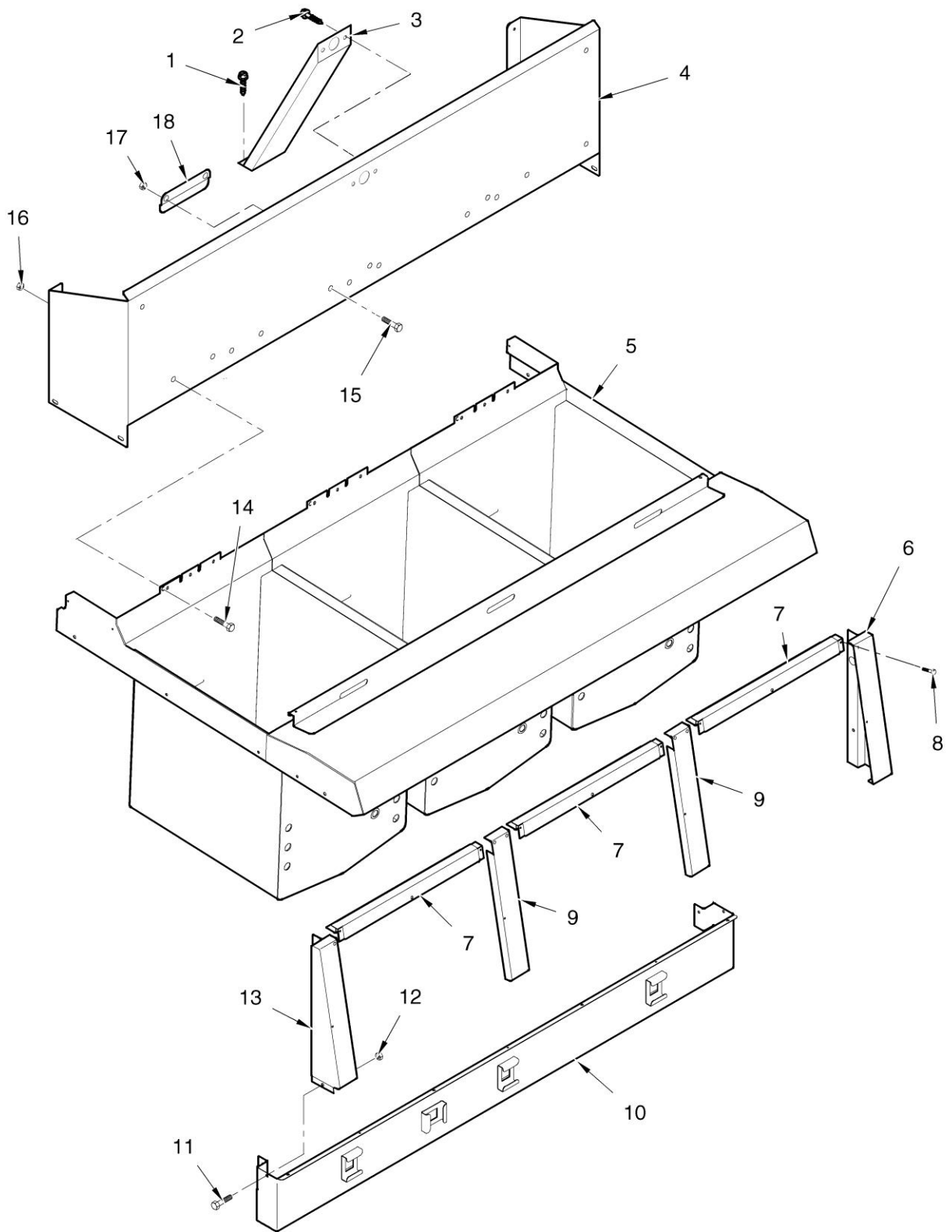

Figure 3-6. Shrouds and Pot & Counter Top

FIGURE & ITEM NO.	PART NO.	DESCRIPTION	QTY. PER UNIT	
			321	322
3-6		SHROUDS AND POT & COUNTER TOP		
1	SC03-005	SCREW, BRACKET RETAINING, BOTTOM	2	2
2	SC01-034	SCREW, BRACKET RETAINING, TOP	2	2
3	60340	BRACKET, REAR SHROUD	1	2
4	63700	REAR SHROUD ASSY.	1	-
4	26870	REAR SHROUD ASSY.	-	1
5	24899	POT & COUNTERTOP ASSY. (OFE-321)	1	-
5	24896	POT & COUNTERTOP ASSY. (OFE-322)	-	1
6	60322	SHROUD CONTROL VERTICAL RH	1	1
7	60328	SHROUD CONTROL UPPER MIDDLE	-	2
8	SC04-003	SCREW	4	9
9	60326	SHROUD CONTROL DIVIDER	-	1
10	71938	BOTTOM SWITCH GUARD (SN: BA0604017 & above)	1	-
10	60605	BOTTOM SWITCH GUARD (SN: BA0604016 & below)	1	-
10	69634	BOTTOM SWITCH GUARD (SN: BA0604017 & above)	-	1
10	60606	BOTTOM SWITCH GUARD (SN: BA0604016 & below)	-	1
11	SC1-034	SCREW	2	2
12	NS02-007	NUT	2	2
13	60324	SHROUD CONTROL VERTICAL LH	1	1
14	SC03-005	SCREW, SHROUD RETAINING	4	4
15	N02-006	NUT, SHROUD RETAINING	4	6
16	N02-006	NUT, RETAINER SECURING	-	2
17	33261	REAR SHROUD RETAINER	-	1

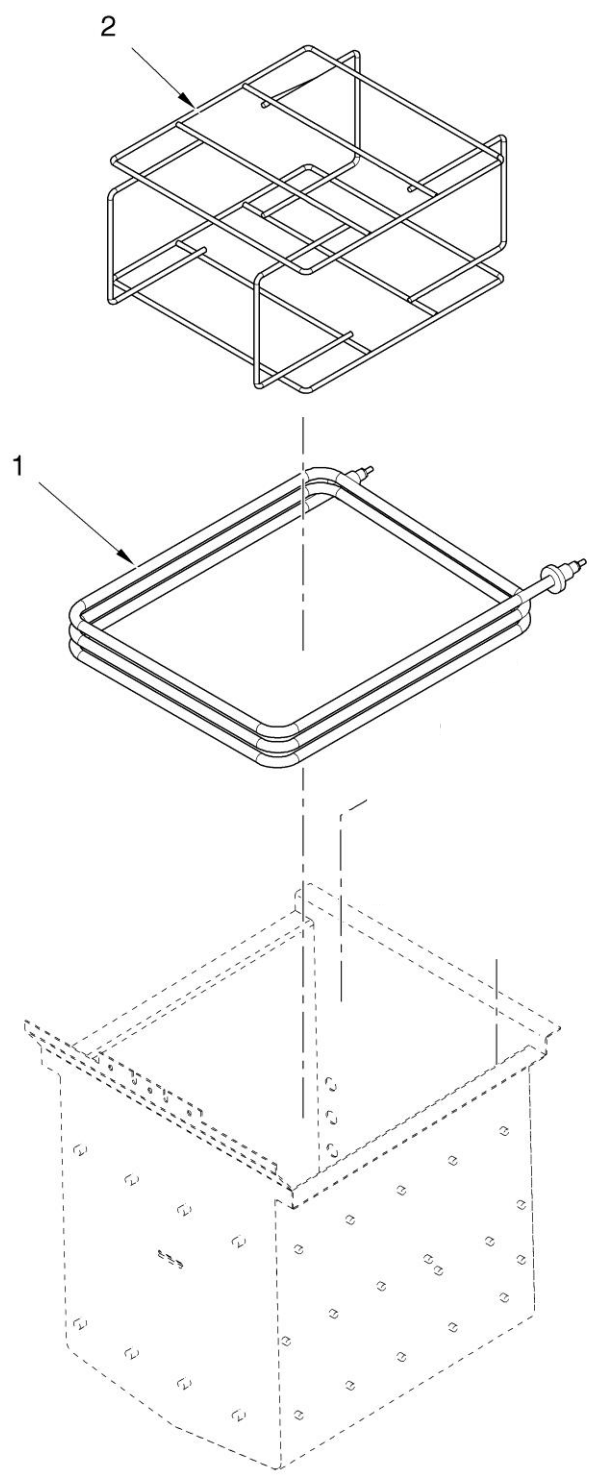
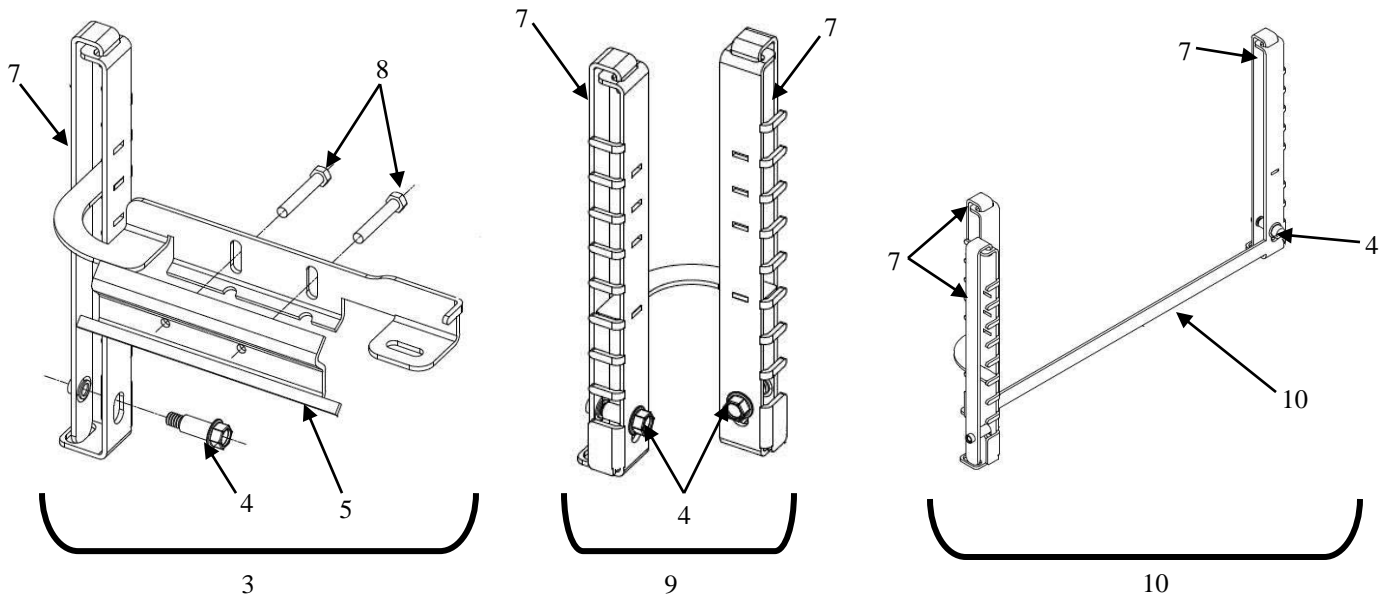

Figure 3-7. Electric Heater

FIGURE & PART NO. ITEM NO.	DESCRIPTION	QTY. PER UNIT	
		321	322
3-7	ELECTRIC HEATER		
√ 1 30292-2	HEATING ELEMENT – 208V 7333W	3	6
√ 1 30292-6	HEATING ELEMENT – 240V 7333W	3	6
√ 1 30292-1	HEATING ELEMENT – 480V 7333W	3	6
2 26917	FRY BASKET SUPPORT	1	2



3	95349	ASSY-HI LIMIT HLDR/SPDR LH	1	2
4	95182	--ASSY-HEX HD SCR/SPCR #10UNF	5	10
5	93270	--CLAMP-HI LIMIT	1	2
6	95350	--WELD ASSY-HI LIMIT HLDR/SPDR L	1	2
7	95354	--RETAINER-ELEMENT SPREADER	5	10
8	SC01-288	--SCREW #8-32 X 1 HEX HD S	2	4
9	95352	ASSY- CORNER SPREADER LH --Includes #4, 7	1	2
10	95246	ASSY- CORNER/SIDE SPRDR RH --Includes #4, 7	1	2

√ recommended parts

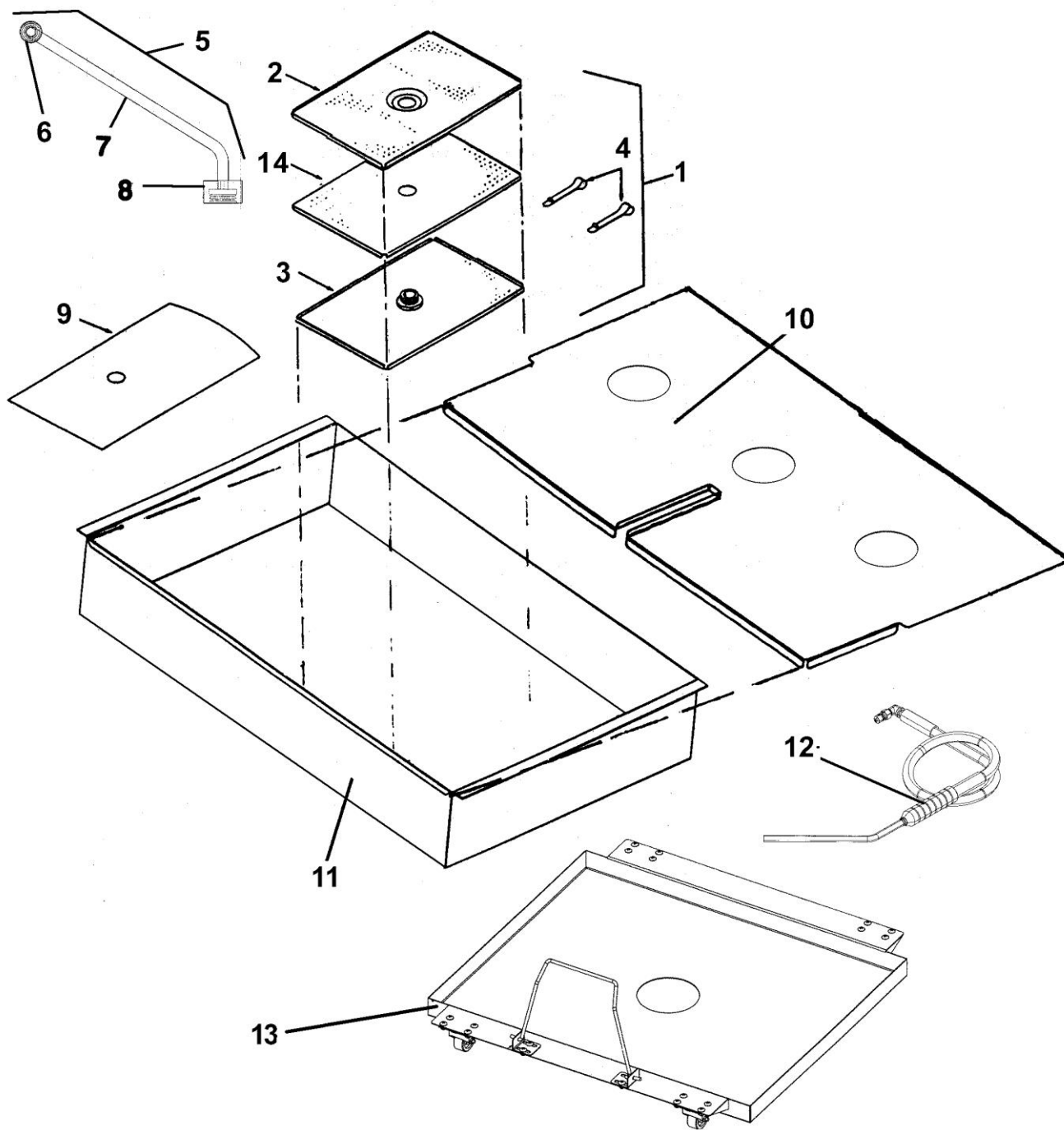

Figure 3-8. Drain Pan, Screen, and Cover

FIGURE & PART NO. ITEM NO.	DESCRIPTION	QTY. PER UNIT	
		321	322
3-8	DRAIN PAN, SCREEN, & COVER		
1	14671 KIT – 32X SS FILTER SCREEN ASSY (INCLUDES #8)	1	1
2	65211 CRUMB CATCHER	1	1
3	65447 BOTTOM FILTER SCREEN	1	1
4	17505 FILTER ENVELOPE CLIPS	2	2
5	69118 ASSY-32X SS FILTER SCREEN PIPE	1	1
√ 6	69289 ASSY – FILTER UNION	1	1
7	70360 STANDPIPE TUBE (SN: BA0604017 & above)	1	1
7	60377 STANDPIPE TUBE (SN: BA0604016 & below)	1	1
8	65208 NUT, FILTER - SS	1	1
9	12102 FILTER ENVELOPE PAPER	5	5
10	81123 DRAIN PAN COVER (321) (SN: 10/7/08 & AFTER)	1	-
10	71597 DRAIN PAN COVER (321) (SN: BA0604017 to 10/7/08)	1	-
10	21064 DRAIN PAN COVER (321) (SN: BA0604016 & below)	1	-
10	71599 DRAIN PAN COVER (322, SN: BA0604017 & above)	-	1
10	24596 DRAIN PAN COVER (322, SN: GM046JB-BA0604016)	-	1
10	60460 DRAIN PAN COVER (322, SN: GM045JB & below)	-	1
11	21088 DRAIN PAN (321) (SN: BA0604016 & below)	1	-
11	70344 DRAIN PAN (321) (BA0604017 to BA0810007)	1	-
11	81120 DRAIN PAN (321) (BA0810008 & ABOVE)	1	
11	66522 DRAIN PAN (322) (SN: BA0604017 & below)	-	1
11	70345 DRAIN PAN (322) (SN: BA0604018 & above)	-	1
12	03003 RINSE HOSE ASSY.	1	1
13	03495 DRAIN PAN DOLLY–321(SN: BN0604042 & BELOW)	1	-
13	03548 DRAIN PAN DOLLY–321(SN: BN0604043 & AFTER)	1	-
13	03496 DRAIN PAN DOLLY–322 (SN: BN0604031 & BELOW)	-	1
13	03549 DRAIN PAN DOLLY–322 (SN: BN0604032 & ABOVE)	-	1
14	17502(USE 14671) TOP FILTER SCREEN	1	1

√ recommended parts

NOTICE

If unit has 3 filter screens, use part no. 14671

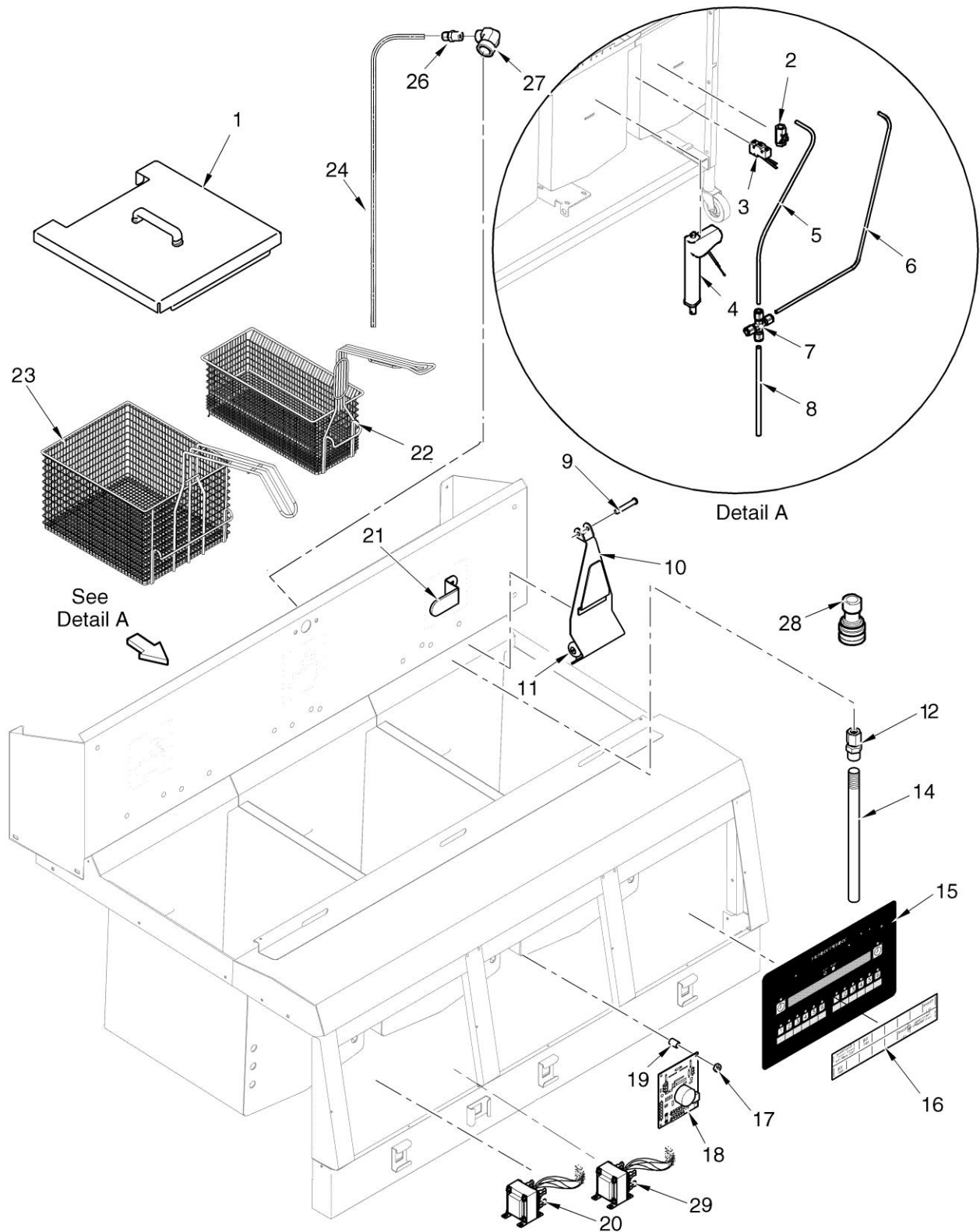

Figure 3-9. Autolift Feature

FIGURE & ITEM NO.	PART NO.	DESCRIPTION	QTY. PER UNIT	
			321	322
3-12		AUTOLIFT FEATURE		
1	50814	FRYPOT COVER, AUTOLIFT	1	2
2	50750	FILTER VALVE, OIL RETURN	1	1
√ 3	50764	MICROSWITCH, RIGID LEVER	1	2
√ 4	50716	ACTUATOR, AUTOLIFT, 24V MOTOR (SN: EN040JB) & BELOW)	2	4
√ 4	63602	ACTUATOR, AUTOLIFT, 24V MOTOR (SN: EN041JB) UP TO BP0812001)	2	4
√ 4	80091	ACTUATOR, AUTOLIFT, 24V MOTOR (SN: BP0812001 & ABOVE)	2	4
5	50780	TUBE, UNION TO WELL 2, FILTER SYSTEM	-	1
6	50779	TUBE, UNION TO WELL 1, FILTER SYSTEM	-	1
7	FP01-129	UNION, TEE, 3/8 IN. TUBE SS, FILTER SYSTEM	-	1
8	50778	TUBE, PUMP TO UNION, FILTER SYSTEM	-	1
9	50776	PIN, ACTUATOR CLEVIS	2	4
10	50865	BASKET HANGER ASSY.	2	4
11	31421	...BEARING WITH SCREW	4	8
12	FP01-128	CONNECTOR (3/8 IN. TUBE TO 3/8 IN. NPT SS), FILTER SYSTEM	-	1
13*	NS03-023	...NUT, 1/4-20 ACORN CAP	4	8
14	50785	TUBE, OIL RETURN, LONG, FILTER SYSTEM	-	1
14	60611	RETURN FAUCET ASSY. (WITH 17334 DISCONNECT)	1	1
√ 15	60796RB	GM 12 BUTTON CONTROL (321)	1	2
16	61562	MENU CARD, AUTOLIFT	2	4
17	NS02-005	NUT	4	8
√ 18	50290	BASKET LIFT PCB ASSY.	1	2
19	ME50-024	SPACER	4	8
√ 20	30614	TRANSFORMER (208/240V-PRI, 24V-SEC.)	1	2
21	59721	RETURN VALVE HANDLE	-	2
22	50704	1/2 SIZE BASKET	2	4
23	50703	FULL SIZE BASKET	1	2
24	26901	TUBE, OIL RETURN LINE (before 12-1-06)	1	-
24	73957	TUBE, OIL RETURN LINE (after 12-1-06)	1	-
25*	50786	TUBE, 2.00 NIPPLE, FILTER SYSTEM	-	1
26	FP01-082	CONNECTOR (3/8 TUBE TO 1/2 NPT SS)	1	-
27	FP01-087	ELBOW	1	1
28	17333	DISCONNECT – FEMALE (USED W/60611)	1	1
29	TS22-012	TRANSFORMER – AUTOLIFT	1	2

√ recommended parts
*not shown