



**Henny Penny  
Open Fryer Technical  
Manual**

**Model OFE-141**

**Model OFE-142**

**FM06-052-F  
10-18-16**

## NOTICE

This manual and Wiring diagram should be retained in a convenient location for future reference. The Model OFE-14X open fryer cannot be operated without electric power. The unit will automatically return to normal operation when power is restored.



**Improper installation, adjustment, alteration, service, or maintenance can cause property damage, injury, or death. Read the installation, operating, and maintenance instructions thoroughly before installing or servicing this equipment.**



**DO NOT STORE OR USE GASOLINE OR OTHER FLAMMABLE VAPORS AND LIQUIDS IN THE VICINITY OF THIS OR ANY OTHER APPLIANCE. FIRE OR EXPLOSION COULD RESULT.**

# TABLE OF CONTENTS

Section	Page
<b>Section 1. INTRODUCTION</b>	
1-1. Introduction.....	1
1-2. Features .....	1
1-3. Proper Care .....	1
1-4. Assistance .....	1
1-5. Safety .....	1
<b>Section 2. INSTALLATION</b>	
2-1. Introduction.....	3
2-2. Unpacking.....	3
2-3. Leveling the Open Fryer .....	3
2-4. Ventilation of Open Fryer .....	3
2-5. Electrical Requirements OFE-14X .....	4
<b>Section 3. OPERATION</b>	
3-1. Operating Components- C1000 Controls.....	5
3-2. Filling or Adding Shortening.....	11
3-3. Care of Shortening .....	11
3-4. Filtering of Shortening (Optional Feature).....	12
3-5. Filter Pump Problem Prevention (Optional Feature) .....	13
3-6. Filter Pump Motor Protector - Manual Reset (Optional Feature) .....	14
3-7. Changing the Filter Envelope (Optional Feature).....	14
3-8. Cleaning the Frypot .....	15
3-9. Regular Maintenance .....	17
3-10. Wiring Diagram .....	18
<b>Section 4. PART LIST</b>	
4-1. GENERAL ASSY-OFE142 SPLIT VAT .....	24
4-2. GENERAL ASSY-OFE142 FULL VAT .....	25
4-3. GENERAL ASSY-OFE141 SPLIT VAT .....	26
4-4. GENERAL ASSY-OFE141 FULL VAT .....	27
4-5. ASSY POT-OFE142 SPLIT VAT .....	28
4-6. ASSY POT-OFE142 FULL VAT.....	29
4-7. ASSY POT-OFE141 SPLIT VAT .....	30
4-8. ASSY POT-OFE141 FULL VAT.....	31
4-9. ELECTRICAL PARTS.....	32
4-10. ASSY-CONTROL PANEL.....	33
4-11. ASSY- ELEMENT & HUB-SPLIT VAT .....	34
4-12. ASSY- ELEMENT & HUB-FULL VAT .....	36
4-13. MOTOR AND PUMP .....	38
4-14. GDS-ROD ASSY .....	39
4-15. PIPING SYSTEM-OFE142 FULL VAT (PUMP VERTICAL) .....	40
4-16. PIPING SYSTEM-OFE142 FULL VAT (PUMP HORIZONTAL).....	41
4-17. PIPING SYSTEM-OFE142 SPLIT VAT (PUMP VERTICAL).....	42
4-18. PIPING SYSTEM-OFE142 SPLIT VAT (PUMP HORIZONTAL) .....	43
4-19. PIPING SYSTEM-OFE141 SPLIT VAT (PUMP VERTICAL).....	44
4-20. PIPING SYSTEM-OFE141 SPLIT VAT (PUMP HORIZONTAL) .....	45-46
4-21. PIPING SYSTEM-OFE141 FULL VAT (PUMP VERTICAL) .....	47
4-22. PIPING SYSTEM-OFE141 FULL VAT (PUMP HORIZONTAL).....	48-49
4-23. DOOR ASSY-OFE141.....	50
4-24. LH DOOR ASSY- OFE142 .....	51

4-25. RH DOOR ASSY - OFE142.....52  
4-26. DRAIN PAN-OFE142 FULL VAT .....53  
4-27. DRAIN PAN-OFE142 SPLIT VAT .....54  
4-28. ACCESSORY .....55

**Section 5. TROUBLESHOOTING**

5-1. Troubleshooting Guide .....56  
5-2. Error Codes .....57

## **SECTION 1. INTRODUCTION**

### **1-1. INTRODUCTION**

equipment

only in

The Henny Penny Open Fryer is a basic unit of food designed to cook foods better and easier. This unit is used in institutional and commercial foodservice operations.

### **1-2. FEATURES**

- Easily cleaned
- 55 lb-65lb. (24.94-29.47 kg.) shortening capacity
- 2 Half size baskets per well (option)
- Stainless steel construction
- Manual reset high limit control
- Gravity drain filter system

### **1-3. PROPER CARE**

As in any unit of food servicing equipment, the open fryer does require care and maintenance. Requirements for the maintenance and cleaning are contained in this manual and must become a regular part of the operation of the unit at all times.

### **1-4. ASSISTANCE**

Should you require outside assistance, call your local independent Henny Penny distributor in your area, call Henny Penny Corp. at 0512-89180268 , or go to Henny Penny online at [www.hennypenny.com](http://www.hennypenny.com).

### **1-5. SAFETY**

The Henny Penny Open Fryer has many safety features incorporated. However, the only way to ensure safe operation is to fully understand the proper installation, operation, and maintenance procedures. The instructions in this manual have been prepared to aid you in learning the proper procedures. Where information is of particular importance or is safety related, the words DANGER, WARNING, CAUTION, or NOTE are used. Their usage is described on the next page:

**1-5. SAFETY (continued)**



SAFETY ALERT SYMBOL is used with DANGER, WARNING or CAUTION which indicates a personal injury type hazard.



NOTICE is used to highlight especially important information.



CAUTION used without the safety alert symbol indicates a potentially hazardous situation which, if not avoided, may result in property damage.



**CAUTION used with the safety alert symbol indicates a potentially hazardous situation which, if not avoided, could result in minor or moderate injury.**



**WARNING indicates a potentially hazardous situation which, if not avoided, could result in death or serious injury.**



**DANGER INDICATES AN IMMINENTLY HAZARDOUS SITUATION WHICH, IF NOT AVOIDED, WILL RESULT IN DEATH OR SERIOUS INJURY.**



Equalization bonding stud

## SECTION 2. INSTALLATION

### 2-1. INTRODUCTION

This section provides the installation instructions for the Henny Penny Open Fryer.



Installation of the unit should be performed only by a qualified service technician.



**Do not puncture the unit with any objects such as drills or screws as component damage or electrical shock could result.**

### 2-2. UNPACKING

The Henny Penny Open Fryer has been tested, inspected, and expertly packed to ensure arrival at its destination in the best possible condition. The unit is banded to a wooden skid and then packed inside a heavy cardboard carton with sufficient padding to withstand normal shipping treatment.



Any shipping damage should be noted in the presence of the delivery agent and signed prior to his or her departure.

### 2-3. LEVELING THE OPEN FRYER

For proper operation, the open fryer should be level from side to side and front to back. Using a level placed on the flat areas around the frypot collar, adjust the casters until the unit is level.

### 2-4. VENTILATION OF OPEN FRYER

The open fryer should be located with provision for venting into an adequate exhaust hood or ventilation system. This is essential to permit efficient removal of the steam exhaust and frying odors. Special precaution must be taken in designing an exhaust canopy to avoid interference with the operation of the open fryer. We recommend you consult a local ventilation or heating company to help in designing an adequate system.

### 2-5. ELECTRICAL REQUIREMENTS OFE-14X

Refer to the table below for supply wiring and fusing.  
VOLT (V) PH WATTS (KW) AMP (A)

380	3	14	21.2
415	3	14	19.45



To avoid electrical shock, this fryer must be adequately and safely grounded (earthed). Refer to local electrical codes for correct grounding (earthing) procedures or in absence of local codes, with The National Electrical Code, ANSI/NFPA No. 70-(the current edition).

**(FOR EQUIPMENT WITH CE MARK ONLY!)** To prevent electric shock hazard this appliance must be bonded to other appliances or touchable metal surfaces in close proximity to this appliance with an equipotential bonding conductor. This appliance is equipped with an equipotential lug for this purpose. The equipotential lug is marked with the following symbol 

To avoid electrical shock, this appliance must be equipped with an external circuit breaker which will disconnect at overvoltage category III condition all ungrounded (unearthed) conductors. For the installation the national wiring code must be obeyed.' The main power switch on this appliance does not disconnect all line conductors





- CE units require a minimum wire size of 4mm to be wired to the terminal block. If a flexible power cord is used, it must be HO7RN type.
- The supply power cords shall be oil-resistant, sheathed flexible cable, no lighter than ordinary polychloroprene or other equivalent synthetic elastomer-sheathed cord.
- It is recommended that a 30 mA rated protective device such as a residual current circuit breaker (RCCB), or ground fault circuit interrupter (GFCI), be used on the fryer circuit.



## SECTION 3. OPERATING

### 3-1-1. Operating Components- C1500 Controls

Reference Figure 3-1.

<b>Fig. No.</b>	<b>Item No.</b>	<b>Description</b>	<b>Function</b>
3-1	1	Digital Display	Shows the shortening temperature, the timer countdown in the Cook Cycle, and the selections in the Program Mode; the temperature of the shortening can be shown by pressing  once, or twice to view set-point temperature; if shortening temperature exceeds 425°F (218°C), the display reads “E-5, FRYER TOO HOT”
3-1	2		This LED lights when the shortening temperature is within 5° of the set-point temperature, signaling the operator that the shortening temperature is now at the proper temperature for dropping product into the frypot
3-1	3		The timer buttons are used to start and stop Cook Cycles; exit the Melt Cycle; press and hold in the “INIT” Special Program Mode to re-initialize the controls
3-1	4		Used to adjust the value of the currently displayed setting in the Program Mode
3-1	5		The program button is used to access the Program Modes and used to advance to the next parameter; also, once in the Program Mode the LED above the button is lit
3-1	6	Menu Card	The name of the food product associated with each product Window selection button; the menu card strip is located behind the decal
3-1	7	Product Select Buttons	Used to select the product for cooking and the LED above the selected product is lit

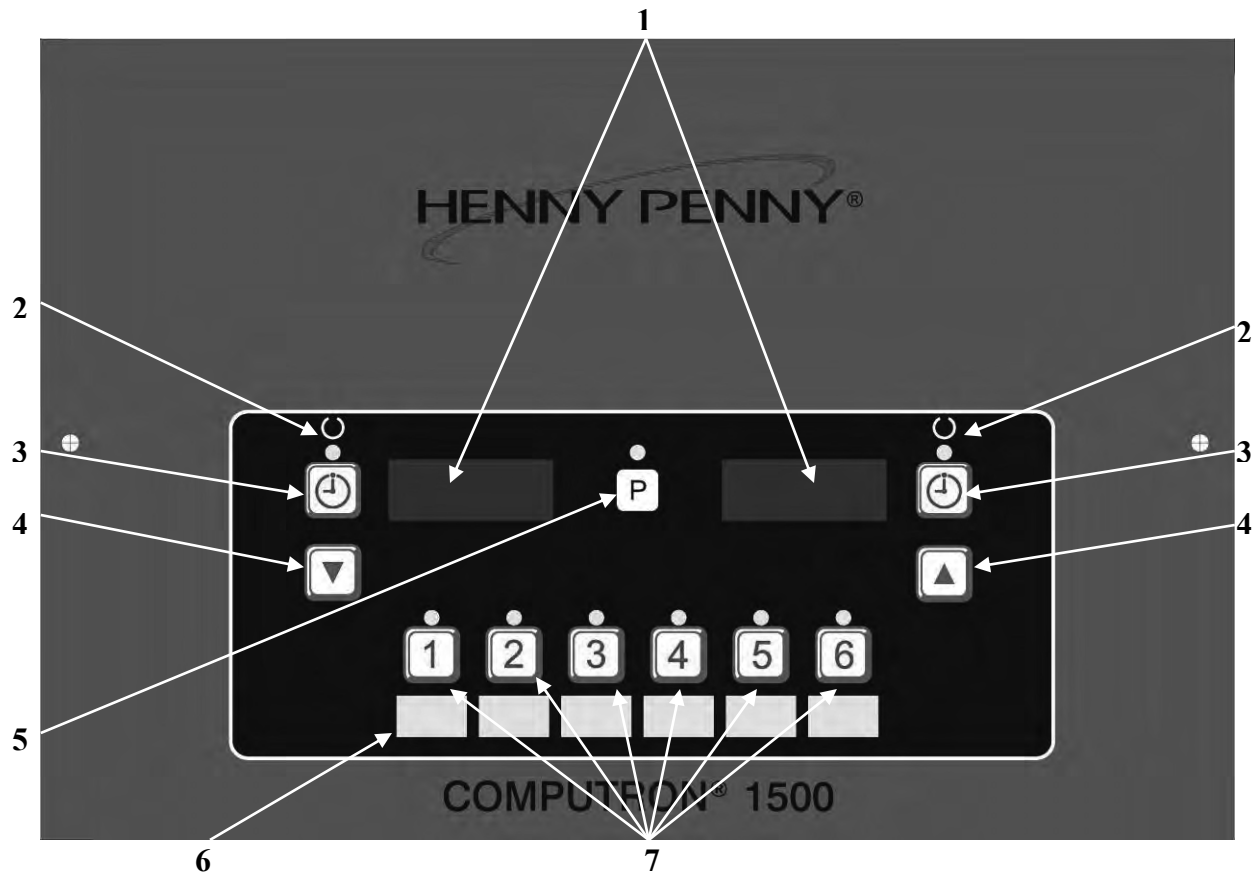

Figure 3-1

**C1500 OPERATIONS  
AND PROCEDURES**

The Computron 1500 controls are available on both split frypot and full frypot fryers. The following is a brief description of the operating procedures for fryers with these controls.

1. Be sure the drain valve is in the closed position.
2. Place basket support inside of frypot.
3. Make sure frypot is filled with shortening to the proper level.
4. Display shows “OFF” until power switch is turned to the ON position. Display shows the selected product as “P-1”, “P-2”, “P-3”, etc, and the unit automatically starts the Melt Cycle until the shortening temperature reaches 250°F (121°C). The control automatically exits the Melt Cycle.

To assign a product to a timer button, press product button and then the desired timer button. “XXXX” is displayed if the product doesn’t match the current set-point. To change to a new product (and set-point) press and hold the timer to choose the new set-point. Once the new set-point is chosen, press the timer button to start the cook cycle.

**Full vat operation:** Only products with the same set-point and LED’s on, can be selected for cooking .

**Split vat operation:** Products with two different set-points and LED’s on, can be chosen.

**NOTICE**

The OFE884 series open fryer has several safety devices which shuts-down the electricity supply when they are activated. The above procedures should be followed to restart the open fryer and if the shut down is repeated, a qualified technician should be notified.

The Melt Cycle may be bypassed, if desired, by pressing and holding  for 3 seconds.

**CAUTION**

*Do not bypass the Melt Cycle unless enough shortening on gas fryers and elements on electric fryers. If Melt Cycle is bypassed before all burner tubes or elements are covered, excessive smoking of the shortening, or a fire will result.*



5. Once out of the Melt Cycle, the shortening is heated until  lights and the selected product is displayed.

Thoroughly stir shortening to stabilize the temperature throughout the frypots.



6. Before loading product into the baskets, lower baskets into the hot shortening to keep the product from sticking to the baskets.
7. Once the shortening temperature has stabilized at the set-point temperature, lower the basket with product into the frypot.



**Do not overload, or place product with extreme moisture content into the basket. 9.4lbs. (4.25kg) is the maximum amount of product per frypot (4.7lbs. (2.125 kg) maximum for the split frypot fryers). Failure to follow these directions can result in shortening overflowing the frypot. Serious burns or damage to the unit could result.**

9. If the right basket was dropped into the shortening, then press the right  .  
If the left basket was dropped, then press the left  .
10. The timer on the appropriate side (right or left) starts counting down.











- If an alarm sounds during a cook cycle, press  to stop alarm.
11. At the end of the Cook Cycle a tone will sound and the display flashes “DONE”. Press  button and lift the basket from the shortening.









## **C1500 PROGRAMMING INSTRUCTIONS**

If “LOCK” shows in display when changing set-points or times see Special Programming for unlocking







### **To Change Set-Point Temperatures**

1. Press and hold  until “PROG MODE” shows in the display.
2. Press the desired product button. The LED above the button is on, “TEMP” shows and the set-point temperature flashes.
3. Press   to change the set-point temperature. Press and hold   and the values increases by 5.
4. Once   are released, the set-point is saved after 2 seconds.
5. To reset set-point temperature to default settings, press and hold both   simultaneously.

### **To change Product Cooking Times**

1. Press and hold  until “PROG MODE” shows in the display.
2. Press the desired product button. The LED above the button is on and the set-point temperature flashes.
3. Press  and “TIME” shows the cook time flashes.
4. Press   to change the product cooking time.
5. Once   are released, the time is saved after 2 seconds
6. To reset cooking time to default settings, press and hold both   simultaneously.





















### **Programming Alarm**

1. Press and hold  until “PROG MODE” shows in the display.
2. Press the desired product button. The LED above the button is on and the set-point temperature flashes.
3. Press  twice and “ALRM” shows and 0:00 flashes.
4. Press   to set an alarm in a cook cycle. Example, if an alarm is to sound 30 seconds after starting a 3 minute cook cycle, set alarm to 2:30.
5. Once   are released, the alarm is saved after 2 seconds

**C1500 SPECIAL PROGRAMMING**

Special Programming is used to set the items below:

- Fahrenheit or Celsius
- Initialize System
- Lock or Unlock Controls
- Fryer Type – Open or Pressure
- Heat Source – Electric; Gas w/standing pilot; Gas w/electronic ignition; Gas-Induced Draft
- Vat Type - Split or Full Vat (frypot)
- Oil Type - Solid or Liquid

1. To enter Special Programming, turn off power switch (either side). Press and hold  and turn the power switch back on.
2. “SPEC” “PROG” followed by, “DEG” “°F” or “°C”. Use   to choose “°F” or “°C”.
3. Press  and “INIT” shows in the display.  
Press and hold the right  and display shows “In-3”, “In-2”, “In-1” followed by “Init Sys” “DONE DONE”. The controls now are reset to factory parameters, the time set to 0:00 and temperature 190°F or 88°C.
4. Press  and “LOCK” or “UNLOCK” shows in the displays. Use   to choose “LOCK” or “UNLOCK”.
5. Press  and “FRYR” shows in left display and the right display should show “OPEN”. Use   to change from “OPEN” to “PRES” if needed.
6. Press  and “HEAT” shows in the left display and the type of heat shows in the right display. Use    
to change the heat type: “ELEC” for electric models; “GAS” for units with standing pilot; “SSI” for units with solid state ignition; “IDG” for units with induced draft gas burners.
7. Press  and “VAT” shows in the left display and the type of vat shows in the right display . Use   to choose “SPLIT” or FULL” vat (frypot) type.
8. Press  and “MELT” shows in the left display and Solid” or “LIQD” shows in the right display. Use   to choose “Solid”, if using solid shortening, or “LIQD”, if using liquid shortening.
9. Press and hold  to exit Special Programming at any time.

### **3-2. FILLING OR ADDING SHORTENING**

## **CAUTION**

*The shortening level must always be above the heating elements when the fryer is heating and at the frypot level indicators on the rear of the frypot. Failure to follow these instructions could result in a fire and/or damage to the fryer. Less than level will caught fire. When using solid shortening, it is recommended to melt the shortening on an outside heating source before placing it in the frypots. The heating element must be completely submerged in shortening. Fire or damage to the frypot could result.*

1. It is recommended that a high quality frying shortening be used in the open fryer. Some low grade shortenings have a high moisture content and will cause foaming and boiling over.



**Wear gloves to avoid severe burns when pouring hot shortening into frypot. Shortening and all metal parts that are in contact with the shortening are extremely hot, and take care to avoid splashing.**

2. Cold shortening should be filled to the lower indicator when the frypot has 2 indicator lines,

### **3-3. CARE OF SHORTENING**



**FOLLOW THE INSTRUCTIONS BELOW TO AVOID SHORTENING OVERFLOWING THE FRYPOT, WHICH COULD RESULT IN SERIOUS BURNS, PERSONAL INJURY, FIRE, AND/OR PROPERTY DAMAGE.**

1. Maintain the shortening at the proper cooking level. Add fresh shortening as needed.
2. Discard any shortening which has a bad flavor or shows signs of excessive foaming or boiling. Keep the frypot clean.



**WITH PROLONGED USE, THE FLASHPOINT OF SHORTENING IS REDUCED. DISCARD SHORTENING IF IT SHOWS SIGNS OF EXCESSIVE SMOKING OR FOAMING. SERIOUS BURNS, PERSONAL INJURY, FIRE, AND/OR PROPERTY DAMAGE COULD RESULT.**

**3-4. FILTERING OF  
SHORTENING  
(Optional Feature)**

1. Turn the main switch to the OFF position. Remove and clean the fry basket in soap and water. Rinse thoroughly.



Best results are obtained when shortening is filtered at the normal frying temperature

2. Use metal spatula to remove any build up from the sides of frypot. Do not scrape heating elements on electric models.



*Scraping the electric fryer elements, produces scratches in these surfaces causing breading to stick and burn.*



**The filter drain pan must be placed all the way to the front of the fryer. Be sure dairy union is connected. Failure to follow these instructions causes splashing of shortening and could result in personal injury. Surfaces of fryer and baskets will be hot. Use care when filtering to avoid getting burned.**

3. Slowly turn drain valve handle a half turn. Leave for a few minutes, then slowly, fully open drain valve. This prevents much splashing of the hot shortening as it drains
4. As the shortening drains from the frypot, use brushes on the heating elements. If the drain fills with breading, use straight white brush to push excess breading into the filter drain pan.





**3-4. FILTERING OF SHORTENING**  
**(Optional Feature)**

**(Continued)**

**IF THERE ARE AIR BUBBLES COMING UP IN THE SHORTENING BEFORE ALL SHORTENING IS PUMPED UP, IT'S POSSIBLE THAT THE FILTER CONNECTION AT THE UNION ON THE FILTER TUBE IS NOT TIGHTENED PROPERLY. IF SO, TURN OFF THE PUMP AND WEAR PROTECTIVE GLOVES OR CLOTH WHEN TIGHTENING THE UNION. THIS UNION WILL BE HOT. SEVERE BURNS COULD RESULT.**

5. Pull out the pump handle, pump all of the shortening out of the filter drain pan and back into the frypot. When the pump is pumping air only, move the pump switch from PUMP to OFF.
6. Check the level of the shortening in the frypot. Add fresh shortening if necessary, until it reaches the bottom level indicator line on the right wall of the frypot.



About 10 to 12 filterings can be made with one filter paper envelope, depending on:

- the quantity and type of product fried and filtered
  - the type of breading used
  - the amount of crumbs left inside the filter drain pan. When the filter screen assembly and filter paper become clogged, and the pumping flow slows. Clean the filter screen assembly and change the filter envelope.
7. To continue cooking, move the main POWER switch to the ON position, and shortening reheats.

**3-5. FILTER PUMP PROBLEM**  
**PREVENTION (Optional Feature)**

To help prevent filter pump problems:

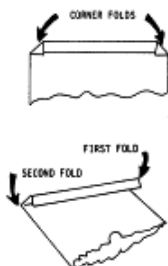

**Figure 3-2**

1. Properly install paper envelope over the filter screens. Fold the open end of the envelope, and clamp with retaining clips so that crumbs cannot enter. Figure 3-2.
2. Pump shortening, until you see bubbles in the fry pot.

**3-6. FILTER PUMP MOTOR  
PROTECTOR – MANUAL RESET  
(Optional Feature)**



In the event it overheats, the filter pump motor is equipped with a manual reset button located on the rear of the motor. After waiting 5 minutes to allow the motor to cool, press the reset button. It takes some effort to reset the motor. A screwdriver can be used to help press reset button. Figure 3-3.



**To prevent burns caused by splashing shortening, turn the unit's filter PUMP switch to the OFF position before resetting the filter pump motor's manual reset protection device.**

**3-7. CHANGING THE FILTER  
ENVELOPE (Optional Feature)**

The filter envelope should be changed after 10-12 filterings or whenever it becomes clogged with crumbs. Proceed as follows:



**The filter union could be hot. Wear protective glove or cloth, or severe burns could result. Use care to prevent burns caused by splashing of hot shortening.**

1. Move the main POWER switch to the OFF position.
2. Disconnect the filter union and remove the filter drain pan from beneath the frypot.
3. Remove the filter screen assembly from the drain pan.
4. Wipe the shortening and crumbs from the filter drain pan. Clean the drain pan with soap and water. Thoroughly rinse with hot water.
5. Unthread the standpipe from the filter screen assembly.
6. Remove the crumb catcher and clean with soap and water. Rinse thoroughly with hot water.
7. Remove the filter clips and discard the filter envelope.
8. Clean the top and bottom filter screen with soap and water. Rinse thoroughly with hot water.

### 3-8. CLEANING THE FRYPOT

After the initial installation of the open fryer, as well as before every change of shortening, the frypot should be thoroughly cleaned as follows:

1. Turn the main POWER switch off



CHEMICAL  
SPLASH  
GOGGLES



CHEMICAL  
RESISTANT  
GLOVES

**The filter drain pan must be as far back under fryer as it will go. Failure to follow these instructions causes splashing of shortening and could result in personal injury.**

**Moving the fryer or filter drain pan while containing hot shortening is not recommended. Hot shortening can splash out and severe burns could result.**

***Always wear chemical splash goggles or face shield and protective rubber gloves when cleaning the frypot as the cleaning solution is highly alkaline. Avoid splashing or other contact of the solution with your eyes or skin.***

**Severe burns may result. Carefully read the instructions on the cleaner. If the solution comes in contact with your eyes rinse thoroughly with cool water and see a physician immediately.**

2. If hot shortening is present in the frypot, it must be drained. Leave for a few minutes, then slowly open the valve to full open position.
3. Close the drain valve. Discard the shortening .
4. Remove the filter screen assembly from the filter drain pan. **The filter union could be hot. Wear protective glove or cloth, or severe burns could result.**
5. Fill the frypot to the level indicator with hot water. Add 4 ozs. (0.12 liters) of open fryer cleaner to the water and mix thoroughly. The fry basket can be placed inside the frypot for cleaning.
6. Turn the main POWER switch to the ON position and set temperature to 195° F (90.5° C).
7. When the solution reaches 195° F (90.5° C), turn the main POWER switch to the OFF position.
8. Let the cleaning solution stand for 15 to 20 minutes with the power off.
9. Using the open fryer brush (never use steel wool), scrub the inside of the frypot.

**3-8. CLEANING THE FRYPOT (Continued)**

**CAUTION**

If the cleaning solution in the frypot starts to foam and boil over, immediately turn the power switch to OFF or damage to components could result.

Do not use steel wool, other abrasive cleaners or cleaners/sanitizers containing chlorine, bromine, iodine or ammonia chemicals, as these will deteriorate the stainless steel material and shorten the life of the unit.

Do not use a water jet (pressure sprayer) to clean the unit, or component damage could result.

10. After cleaning, open the drain valve and drain cleaning solution from the frypot into the filter drain pan and discard.
11. Replace the empty filter drain pan, close the drain valve, and refill the frypot with plain hot water to the proper level.
12. Add approximately 8 ozs. (0.24 liters) of distilled vinegar and bring the solution back up to 195° F (90.5° C).
13. Using a clean brush, scrub the interior of the frypot. This will neutralize the alkaline left by the cleaning compound.
14. Drain the vinegar rinse water and discard.
15. Rinse down the frypot using clean, hot water.
16. Thoroughly dry the filter drain pan and the frypot interior.

**NOTICE**

Make sure the inside of the frypot, the drain valve opening, and all the parts that will come in contact with new shortening are as dry as possible.

17. Replace the clean filter screen assembly in the drain pan, and install filter drain pan under open fryer.
18. Refill the frypot with fresh shortening.

**3-9. REGULAR MAINTENANCE**

As in all food service equipment, the Henny Penny Open Fryer does require care and proper maintenance. The table below provides a summary of scheduled maintenance procedures to be performed by the operator.

<b>Procedure</b>	<b>Frequency</b>
Filtering of shortening	Daily (3-4 loads)
Changing of shortening	When shortening smokes, foams up violently, or tastes bad
Changing the filter envelope	After 10-12 filterings, or when envelope is clogged with crumbs
Cleaning the frypot	Every change of shortening.



**If moving fryer to perform preventive maintenance:  
Electrical supply should be unplugged or wall  
circuit breaker turned off to avoid electrical shock.**





**3-10. OFE14X Wiring Diagram (Continued)**

**OFE142 Split Vat Wire Diagram (—)**

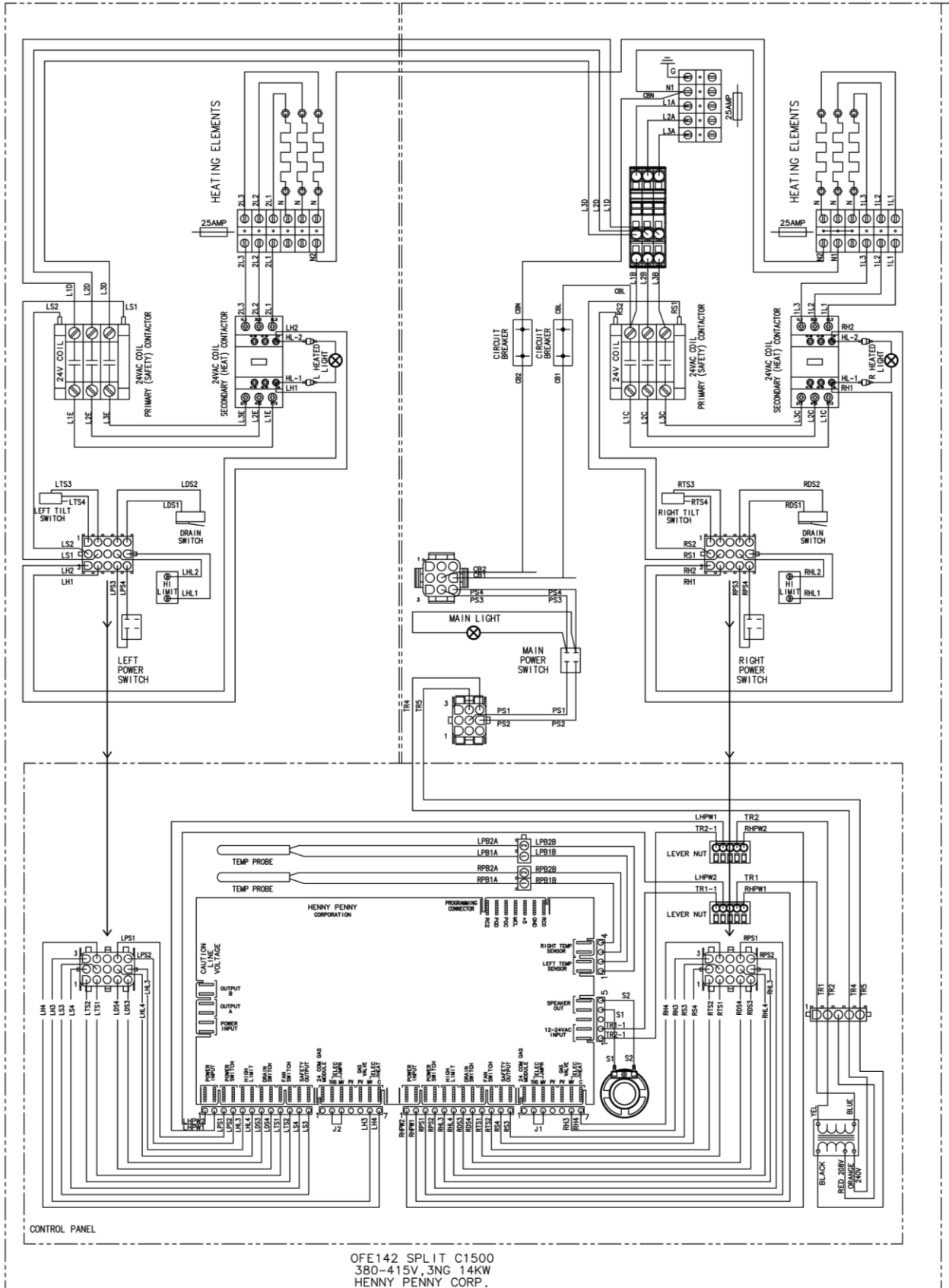



**3-10. OFE14X Wiring Diagram (Continued)**

**OFE142 Split Vat Wire Diagram (二)**

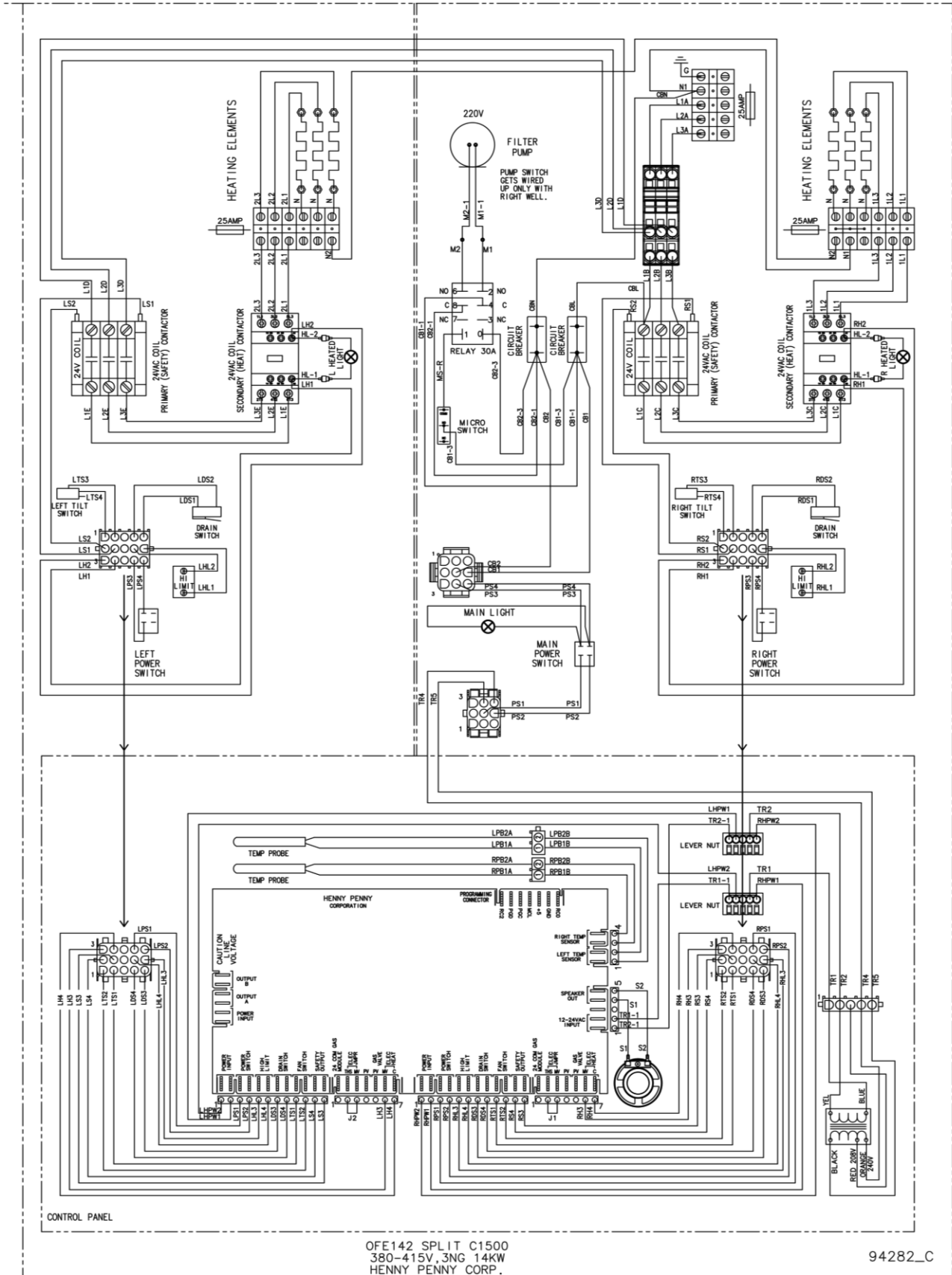

**3-10. OFE14X Wiring Diagram (Continued)**

**OFE142 Full Vat Wire Diagram (—)**

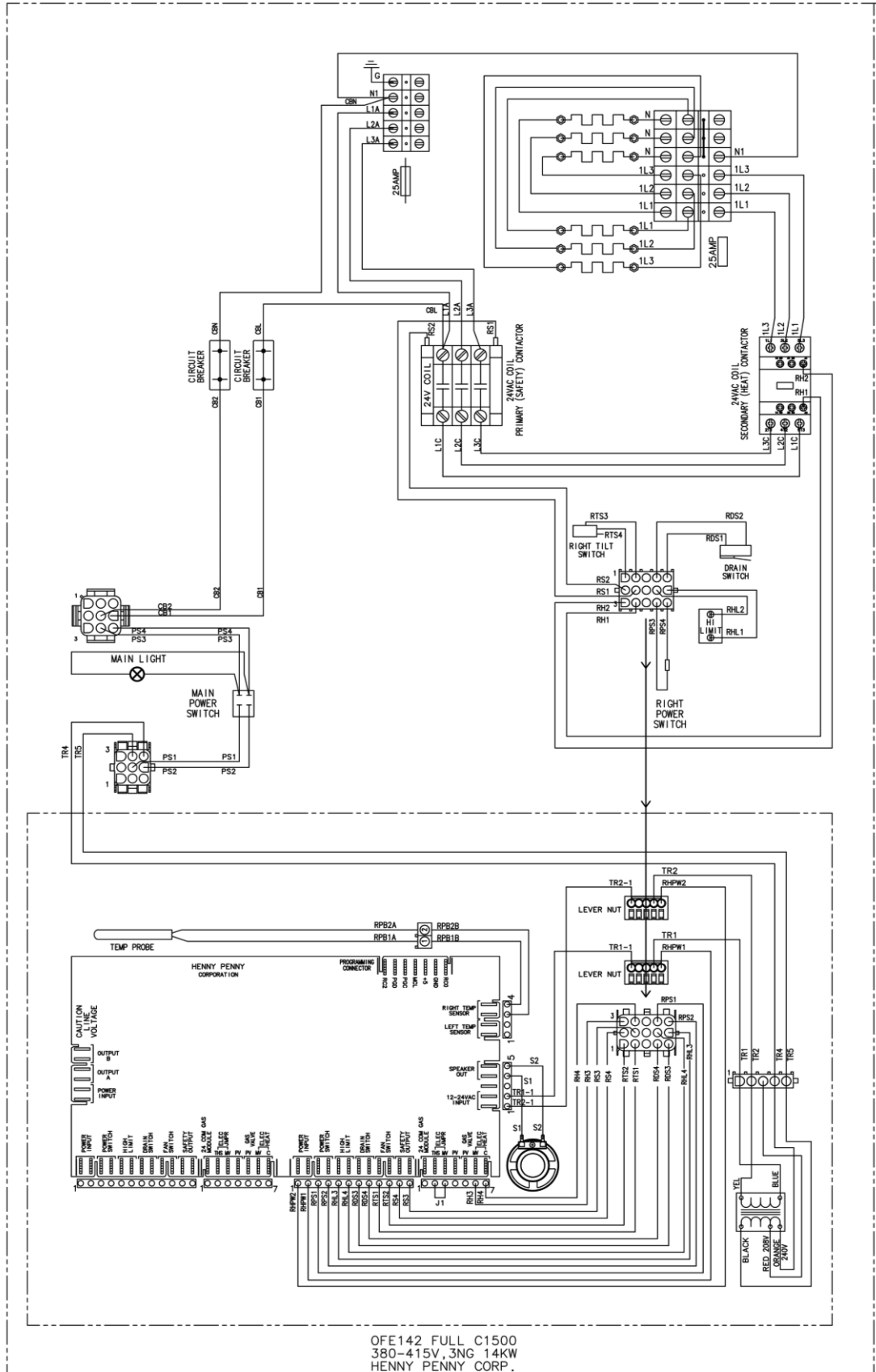

**3-10. OFE14X Wiring Diagram (Continued)**

**OFE142 Full Vat Wire Diagram (二)**

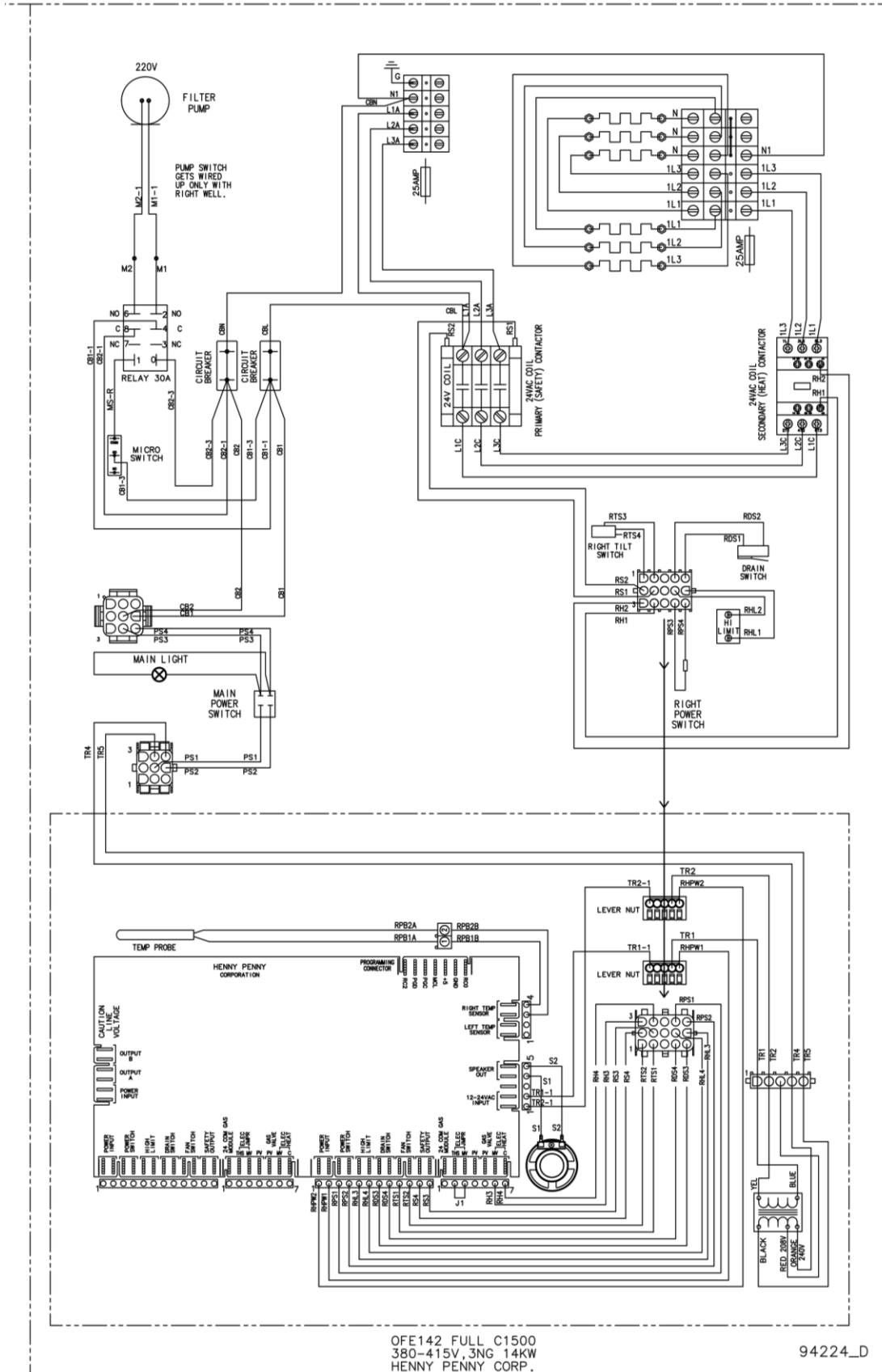

94224\_D

## SECTION 4. PART LIST

### 4-1 GENERAL ASSY-OFE142 SPLIT VAT

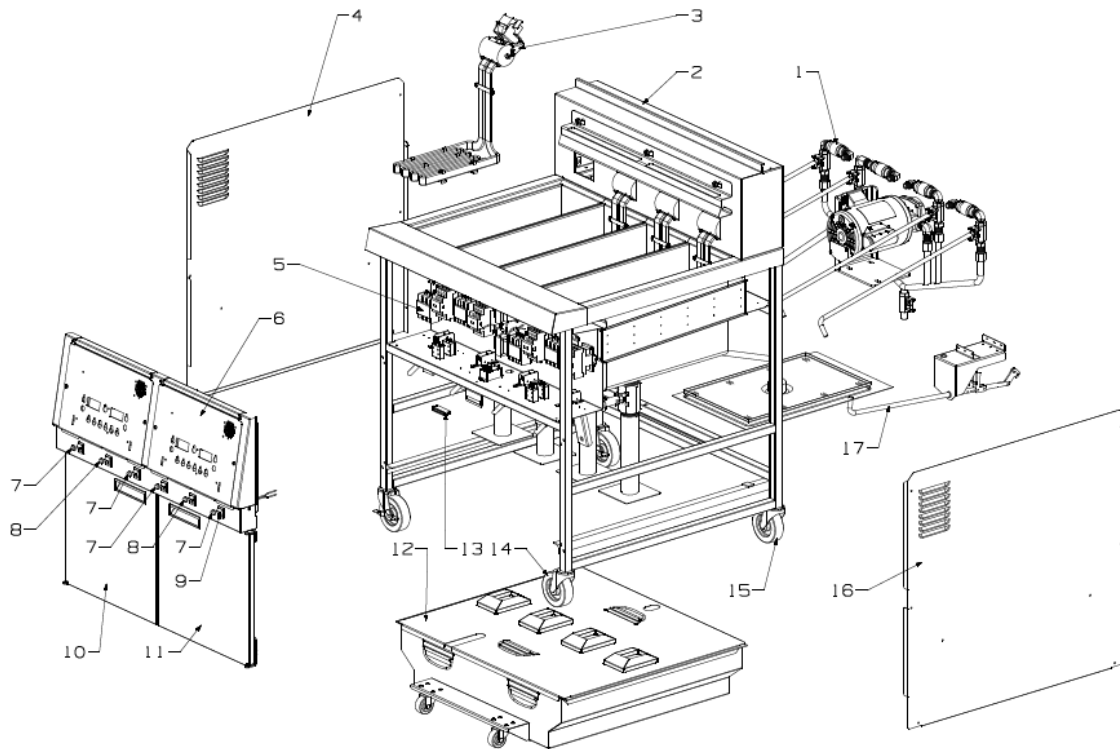

ITEM	PART NUMBER	DESCRIPTION	QUANTITY
1	95896	PIPING SYSTEM	1
2	93654	ASSY-POT AND ENCLOSURE	1
B/3	91632	ASSY-SPLIT ELEMENT & HUB	4
4	92223	PANEL-LH SIDE	1
5	85957	ELECTRICAL PARTS ASSY	1
A/6	140281	KIT-14X C1500 CONTROL ASSY (SN: BF1304003&after)	2
A/6	140284	KIT-14X C1000 CONTROL ASSY (before SN: BF1304003)	2
B/7	38503	LIGHT-INDICATOR 28V	4
B/8	16624	LIGHT - INDICATOR - 250V	2
A/9	52224	COVERED POWER SWITCH	6
10	84842	ASSY-LH DOOR OFE-142	1
11	84843	ASSY-RH DOOR OFE-142	1
12	92171	ASSY-DRAIN PAN-OFE142	1
13	17002	MAGNET	1
14	52064	CASTER 4" SWIVEL W/BRAKE	2
15	60312	CASTER 4 SWIVEL W-O BRAKE	2
16	92196	PANEL-RH SIDE	1
17	93926	ROD ASSY-FULL VAT GPS	1

Recommend Parts: A=Truck Stock, B=Dist. Stock

**4-2 GENERAL ASSY-OFE142 FULL VAT**

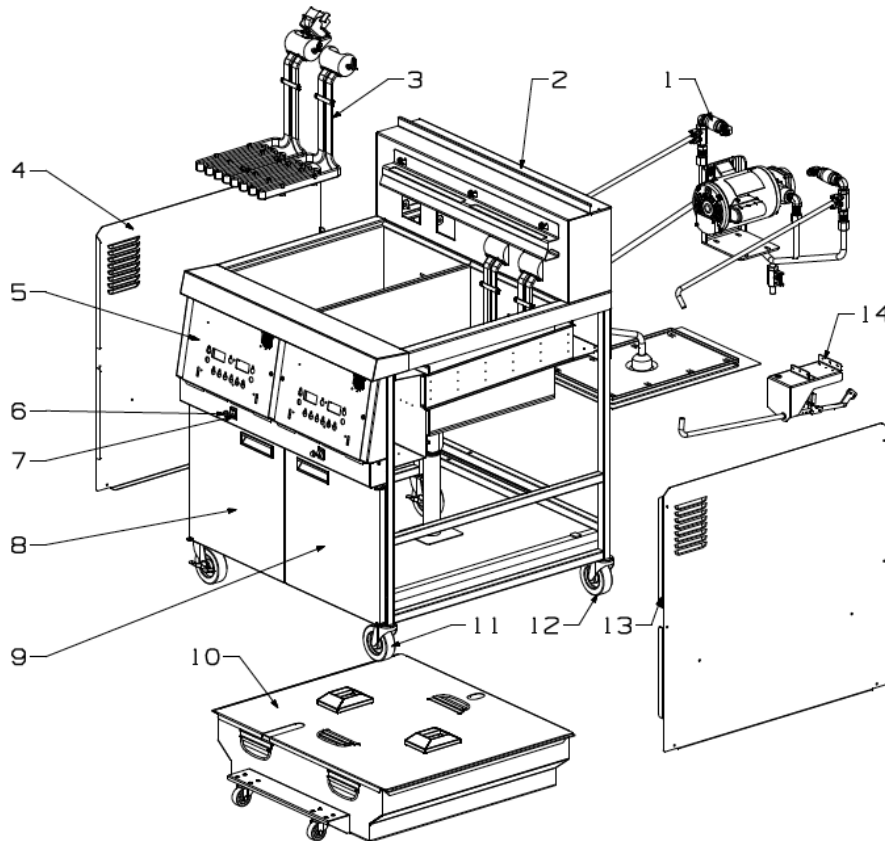

ITEM	PART NUMBER	DESCRIPTION	QUANTITY
1	95785	PIPING SYSTEM	1
2	93631	ASSY-POT AND ENCLOSURE	2
B/3	89184	ASSY-FULL ELEMENT & HUB	2
4	92223	PANEL-LH SIDE	1
A/5	140281	KIT-14X C1500 CONTROL ASSY (SN: BF1304003&after)	2
A/5	140284	KIT-14X C1000 CONTROL ASSY (before SN: BF1304003)	2
B/6	16624	LIGHT - INDICATOR - 250V	2
B/7	52224	COVERED POWER SWITCH	2
8	84842	ASSY-LH DOOR OFE-142	1
9	84843	ASSY-RH DOOR OFE-142	1
10	91628	ASSY-DRAIN PAN-142F	1
11	52064	CASTER 4" SWIVEL W/BRAKE	2
12	60312	CASTER 4 SWIVEL W-O BRAKE	2
13	92196	PANEL-RH SIDE	1
14	93926	ROD ASSY-FULL VAT GPS	1

Recommend Parts: A=Truck Stock, B=Dist. Stock

**4-3 GENERAL ASSY-OFE141 SPLIT VAT**

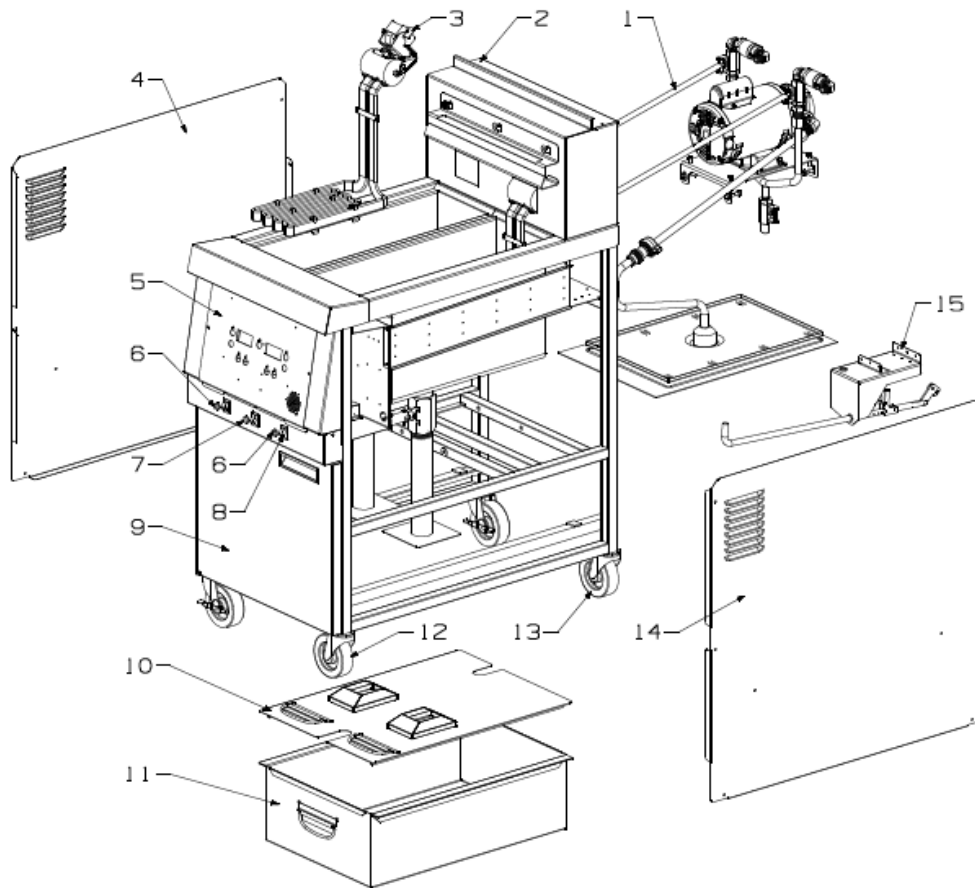

ITEM	PART NUMBER	DESCRIPTION	QUANTITY
1	93978	PIPING SYSTEM-SPLIT VAT GDS	1
2	88758	POT ASSY-OFE141 SPLIT	1
B/3	91632	ASSY-SPLIT ELEMENT & HUB	2
4	92223	PANEL-LH SIDE	1
A/5	140281	KIT-14X C1500 CONTROL ASSY (SN: BF1304003&after)	1
A/5	140284	KIT-14X C1000 CONTROL ASSY (before SN: BF1304003)	1
B/6	38503	LIGHT-INDICATOR 28V	2
B/7	16624	LIGHT - INDICATOR - 250V	1
B/8	52224	COVERED POWER SWITCH	3
9	88697	ASSY-DOOR OFE-141	1
10	88804	WELD ASSY-DRAIN PAN COVER	1
11	88734	WELD ASSY-DRAIN PAN	1
12	52064	CASTER 4" SWIVEL W/BRAKE	2
13	60312	CASTER 4 SWIVEL W-O BRAKE	2
14	92196	PANEL-RH SIDE	1
15	93926	ROD ASSY-FULL VAT GPS	1

Recommend Parts: A=Truck Stock, B=Dist. Stock

**4-4 GENERAL ASSY-OFE141 FULL VAT**

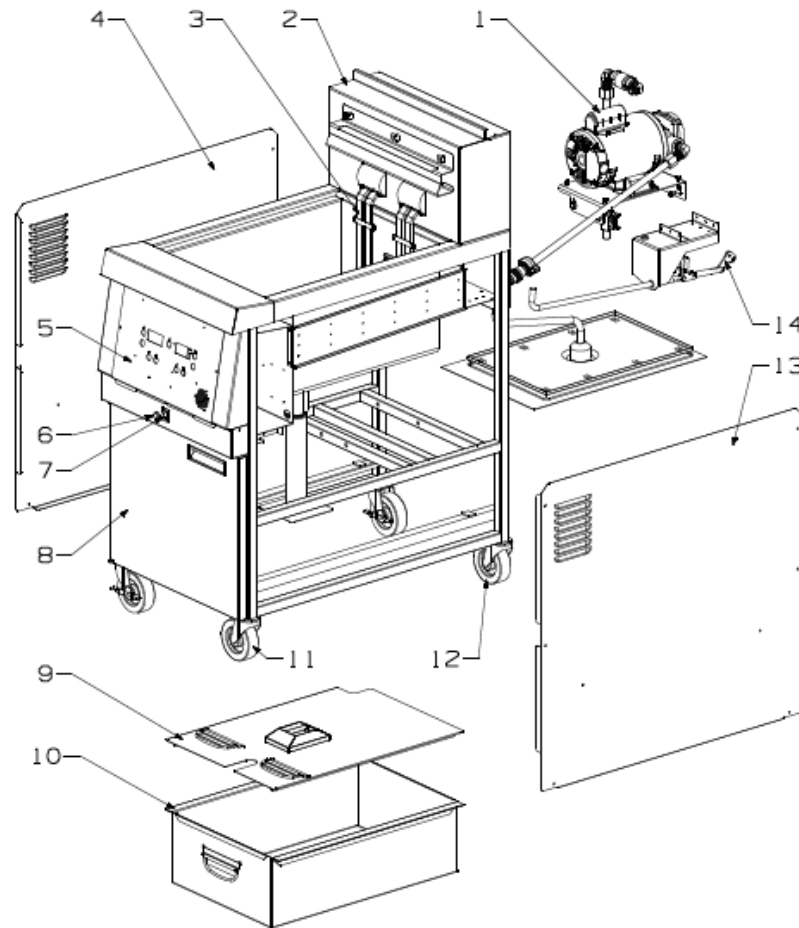

ITEM	PART NUMBER	DESCRIPTION	QUANTITY
1	93887	PIPING SYSTEM-FULL VAT GPS	1
2	88736	POT ASSY-OFE141 FULL	1
B/3	89184	ASSY-FULL ELEMENT & HUB	1
4	92223	PANEL-LH SIDE	1
A/5	140281	KIT-14X C1500 CONTROL ASSY (SN: BF1304003&after)	1
A/5	140284	KIT-14X C1000 CONTROL ASSY (before SN: BF1304003)	1
B/6	16624	LIGHT - INDICATOR - 250V	1
B/7	52224	COVERED POWER SWITCH	1
8	88697	ASSY-DOOR OFE-141	1
9	88731	WELD ASSY-DRAIN PAN COVER	1
10	88734	WELD ASSY-DRAIN PAN	1
11	52064	CASTER 4" SWIVEL W/BRAKE	2
12	60312	CASTER 4 SWIVEL W-O BRAKE	2
13	92196	PANEL-RH SIDE	1
14	93926	ROD ASSY-FULL VAT GPS	1

Recommend Parts: A=Truck Stock, B=Dist. Stock

**4-5 ASSY POT-OFE142 SPLIT VAT**

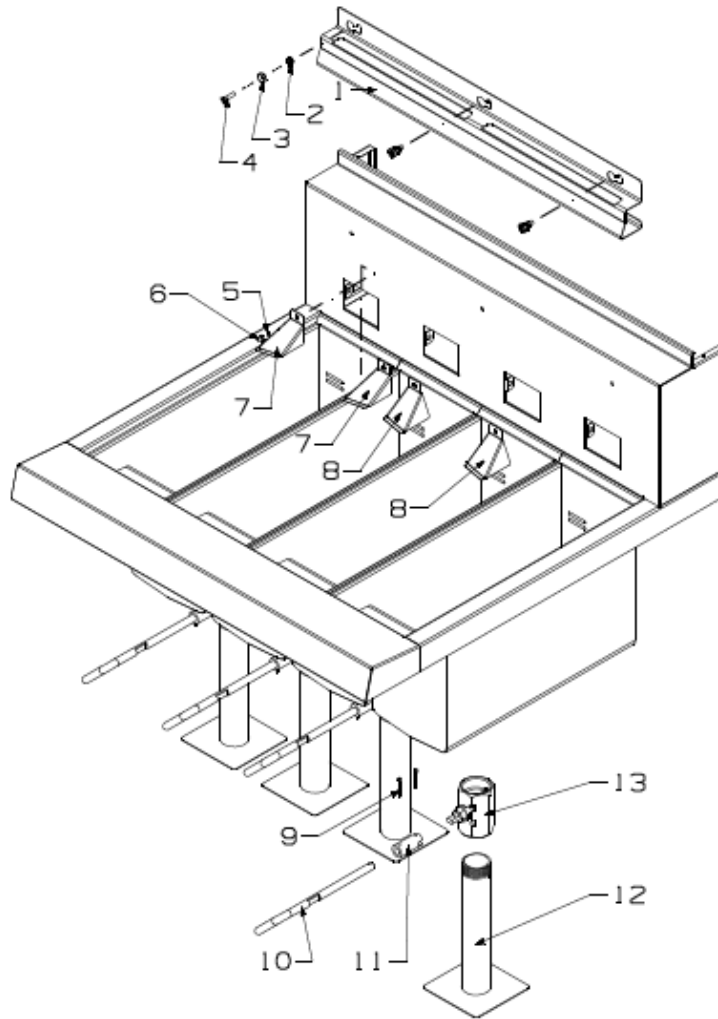

ITEM	PART NUMBER	DESCRIPTION	QUANTITY
1	95809	HANGER-BASKET	1
2	NS02-002	NUT KEPS 1/4-20 C	3
3	95807	SPACER-HANGER	3
4	SC01-068	SCREW 1/4-20 X 1 PH FHD S	3
5	LW01-012	#10 SPLIT RING SS	4
6	NS03-030	NUT #10-32 ACORN	4
7	157422-002	FORM-HOOD OIL DIVERTER-LEFT	2
8	157356-002	FORM-HOOD OIL DIVERTER-RIGHT	2
9	17255	PIN-COTTER	8
10	91348	ROD-NORMALLY OPEN DRAIN	4
11	55142	COUPLING - DRAIN VALVE	4
12	91304	WELD ASSY-E142 DRAIN EXT SQ	4
B/13	17261	VALVE DRAIN BODY ONLY	4



**4-6 ASSY POT-OFE142 FULL VAT**

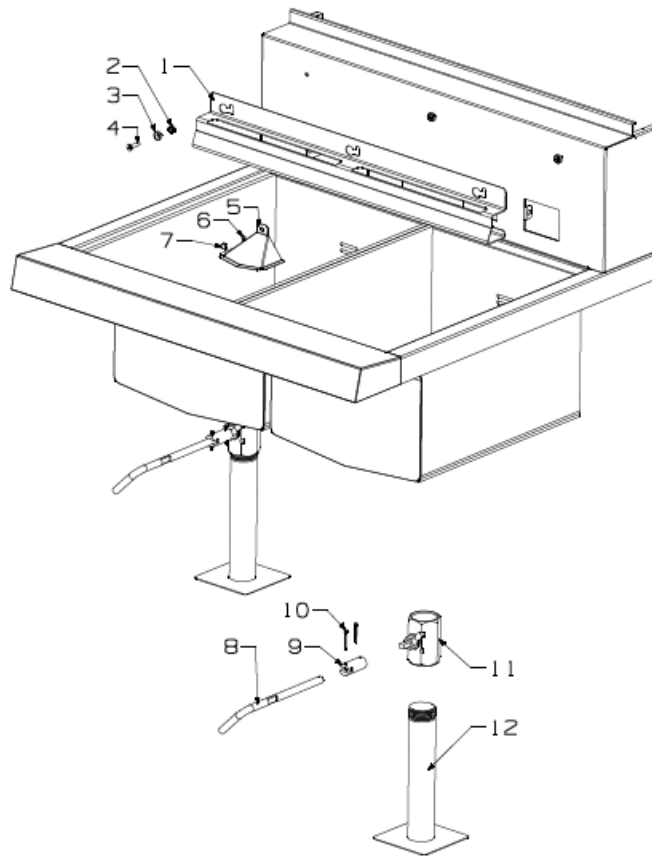

ITEM	PART NUMBER	DESCRIPTION	QUANTITY
1	95809	HANGER-BASKET	1
2	NS02-002	NUT KEPS 1/4-20 C	3
3	95807	SPACER-HANGER	3
4	SC01-068	SCREW 1/4-20 X 1 PH FHD S	3
5	157339-002	FORM-HOOD-OIL DIVERTER	2
6	LW01-012	#10 SPLIT RING SS	2
7	NS03-030	NUT #10-32 ACORN	2
8	91348	ROD-NORMALLY OPEN DRAIN	2
9	55142	COUPLING - DRAIN VALVE	2
10	17255	PIN-COTTER	4
B/11	17261	VALVE DRAIN BODY ONLY	2
12	91304	WELD ASSY-E142 DRAIN EXT SQ	2

Recommend Parts: A=Truck Stock, B=Dist. Stock

**4-7 ASSY POT-OFE141 SPLIT VAT**

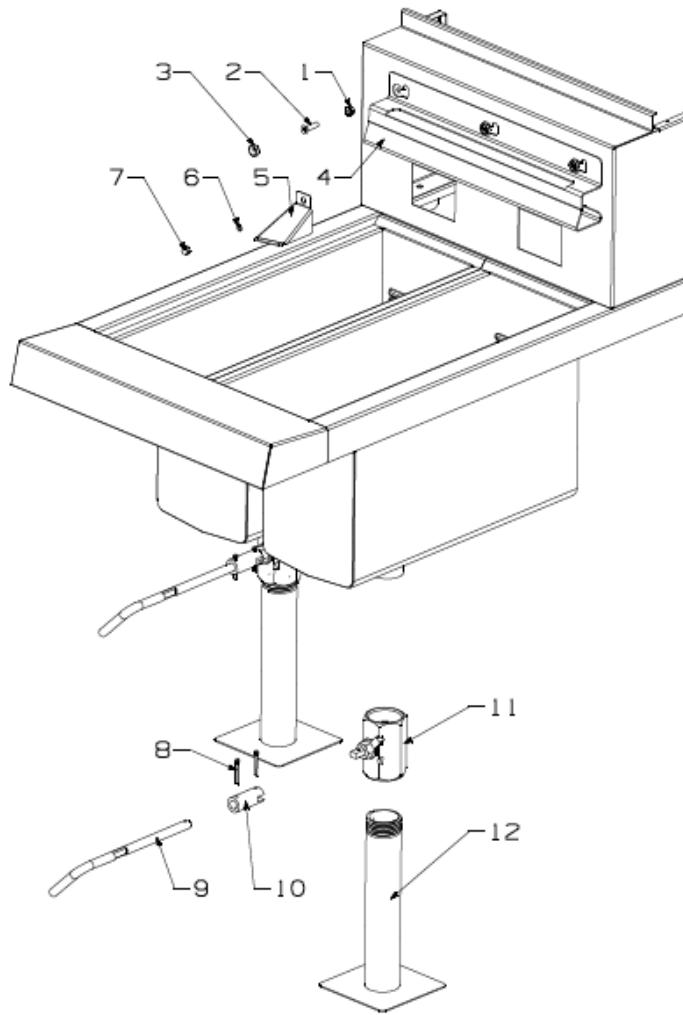

ITEM	PART NUMBER	DESCRIPTION	QUANTITY
1	NS02-002	NUT KEPS 1/4-20 C	3
2	95807	SPACER-HANGER	3
3	SC01-068	SCREW 1/4-20 X 1 PH FHD S	3
4	96342	HANGER-BASKET 141	1
5	157422-002	HOOD-OIL DIVERTER LEFT	2
6	LW01-012	#10 SPLIT RING SS	2
7	NS03-030	NUT #10-32 ACORN	2
8	17255	PIN-COTTER	4
9	91348	ROD-NORMALLY OPEN DRAIN	2
10	55142	COUPLING - DRAIN VALVE	2
B/11	17261	VALVE DRAIN BODY ONLY	2
12	91304	WELD ASSY-E142 DRAIN EXT SQ	2

Recommend Parts: A=Truck Stock, B=Dist. Stock

**4-8 ASSY POT-OFE141 FULL VAT**

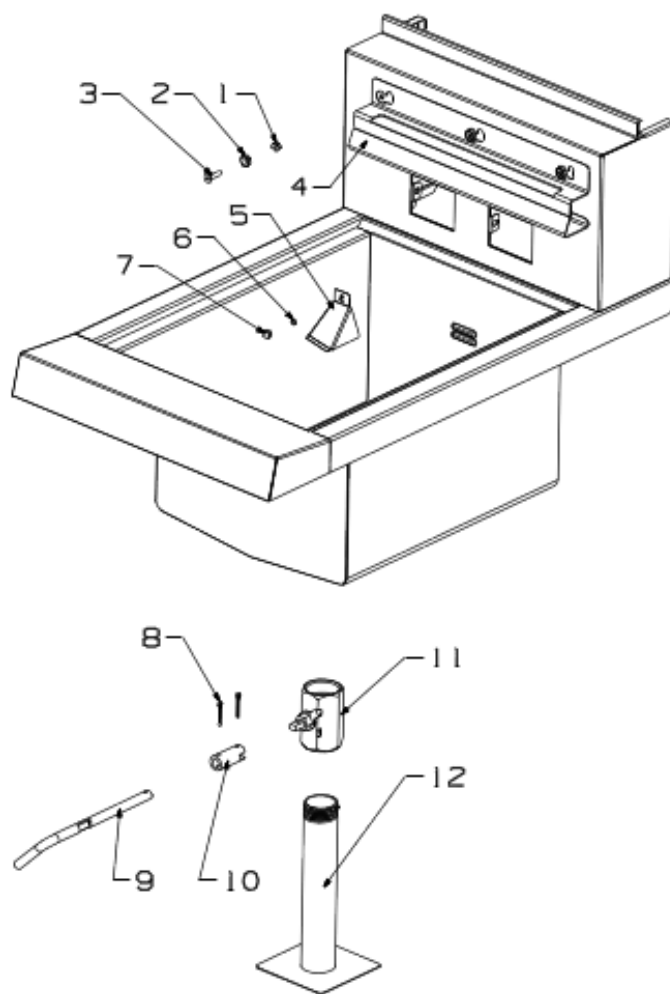

ITEM	PART NUMBER	DESCRIPTION	QUANTITY
1	NS02-002	NUT KEPS 1/4-20 C	3
2	95807	SPACER-HANGER	3
3	SC01-068	SCREW 1/4-20 X 1 PH FHD S	3
4	96342	HANGER-BASKET 141	1
5	157356-002	HOOD-OIL DIVERTER RIGHT	1
6	LW01-012	#10 SPLIT RING SS	1
7	NS03-030	NUT #10-32 ACORN	1
8	17255	PIN-COTTER	2
9	91348	ROD-NORMALLY OPEN DRAIN	1
10	55142	COUPLING - DRAIN VALVE	1
B/11	17261	VALVE DRAIN BODY ONLY	1
12	91304	WELD ASSY-E142 DRAIN EXT SQ	2

Recommend Parts: A=Truck Stock, B=Dist. Stock

**4-9 ELECTRICAL PARTS**

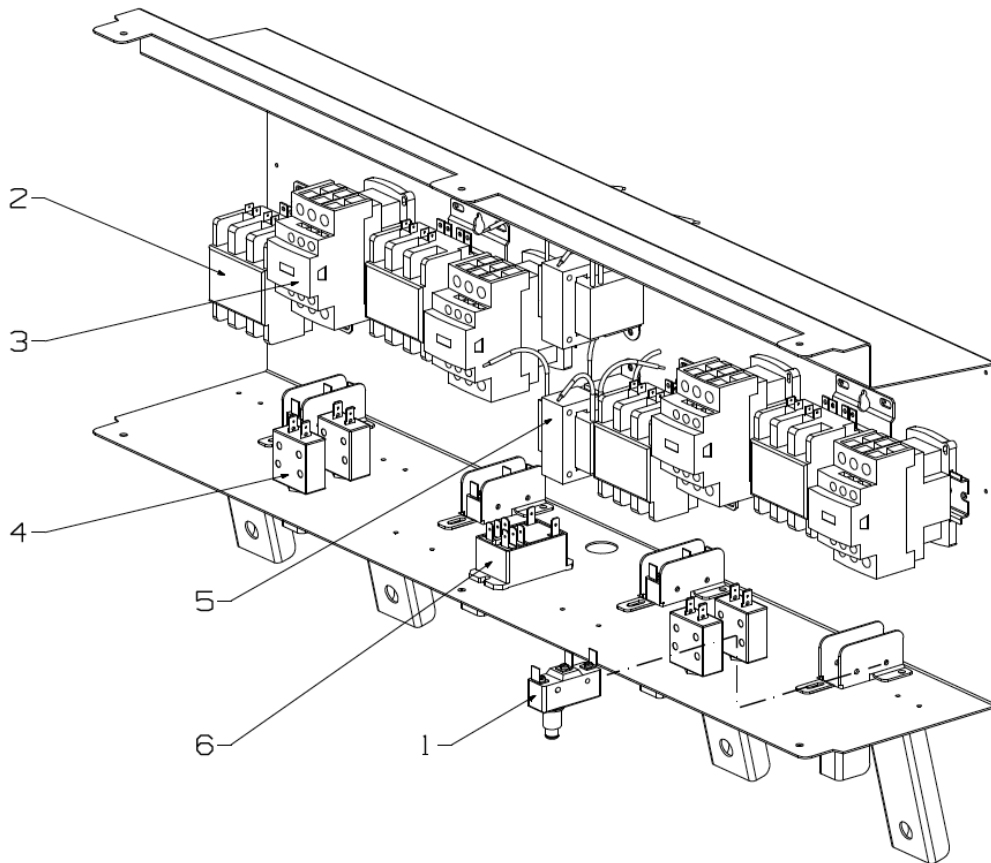

ITEM	PART NUMBER	DESCRIPTION	QUANTITY
A/1	18227	SWITCH-MICRO-250F	1/VAT
A/2	51795	CONTACTOR - 24VAC	1/ VAT
A/3	65073	CONTACTOR-SQUARE D-24V	1/ VAT
A/4	EF02-125	BREAKER-PUSH BUTTON RESET	2/ WELL
A/5	86087	ASSY-24V/240V 75VA TRANSFORMER	1/ WELL
B/6	91727	RELAY-POWER DPDT 240VAC	1

Recommend Parts: A=Truck Stock, B=Dist. Stock

**4-10 ASSY-CONTROL PANEL**

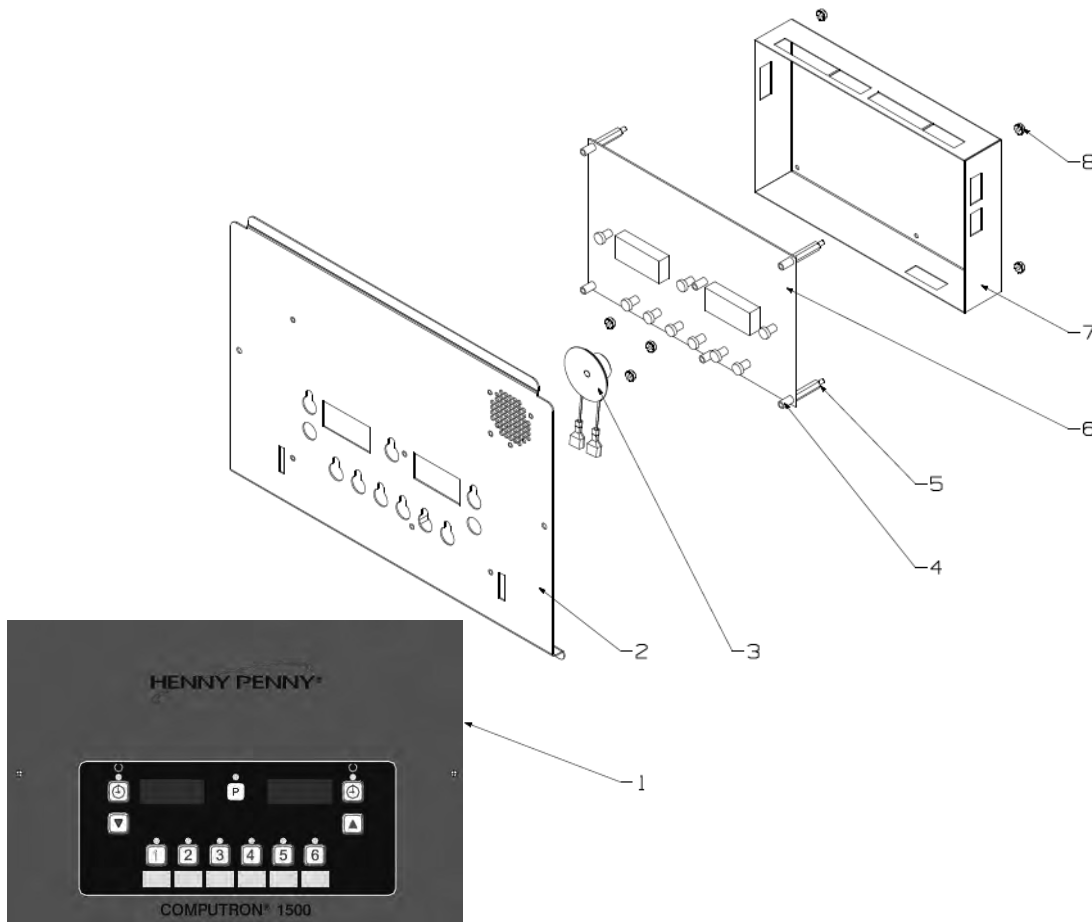

ITEM	PART NUMBER	DESCRIPTION	QUANTITY
1	87332	DECAL-CONTROL PANEL C1500 (SN: BF1304003 & after)	1
1	88742	DECAL-CONTROL PANEL C1000 (before SN: BF1304003 )	
2	87367	STUD ASSY-CONTROL C1500 (SN: BF1304003& after )	1
2	93995	STUD ASSY-CONTROL C1000 (before SN: BF1304003 )	
B/3	ME70-005	SPEAKER-16 OHM-2 INCH	1
4	ME50-053	SPACER-.250ODx.171IDx.453LG AL	6
5	ME50-062	STANDOFF-1/4 HEX M/F 1.125 LG	5
B/6	88440	CONTROL- C1500 GM PCB ASSY (SN: BF1304003& after)	1
B/6	79506	CONTROL-C1000 GM PCB ASSY (before SN: BF1304003 )	
7	89119	COVER-PCB SPLIT	1
8	NS02-005	NUT HEX KEPS #6-32 C	9

Recommend Parts: A=Truck Stock, B=Dist. Stock

**4-11 ASSY- ELEMENT & HUB-SPLIT VAT**

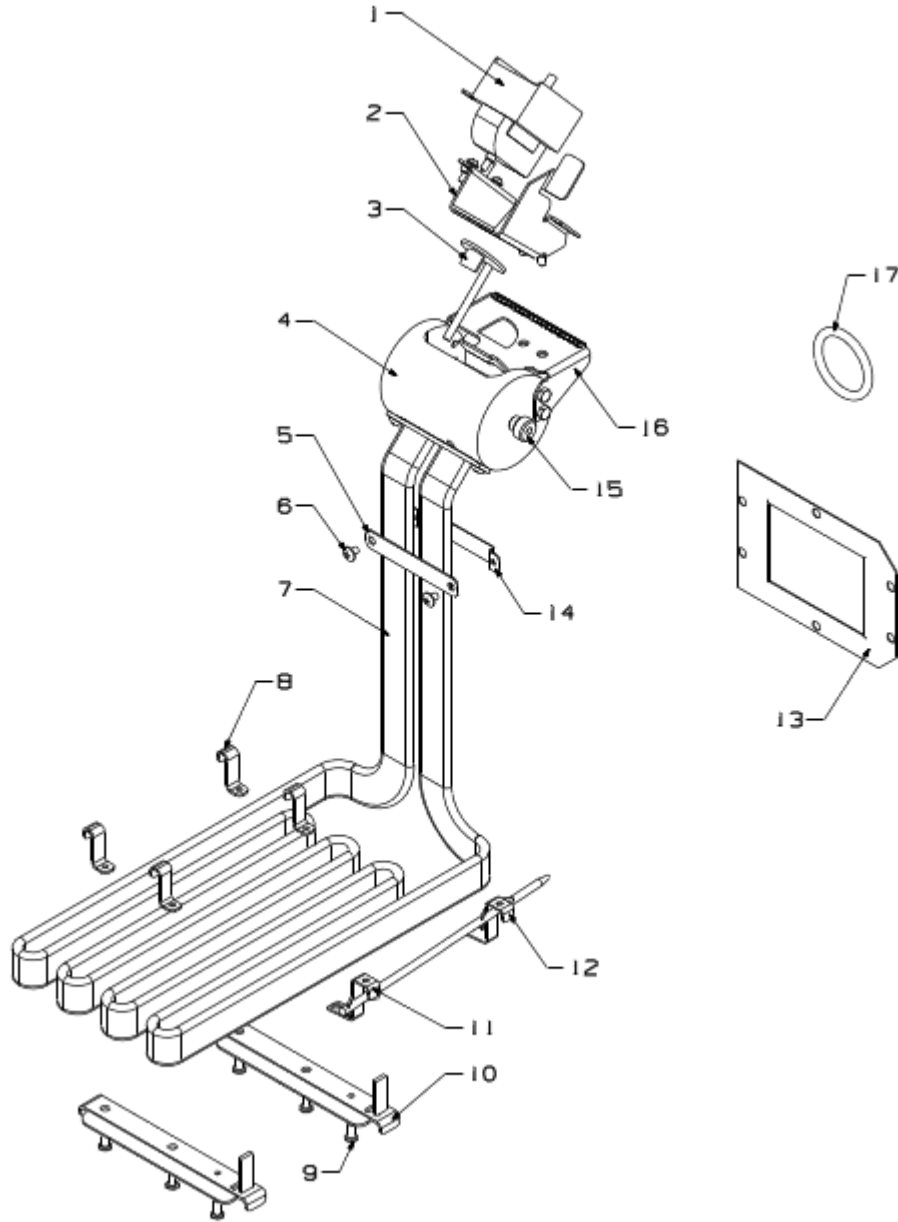

**4-11 ASSY- ELEMENT & HUB-SPLIT VAT**

ITEM	PART NUMBER	DESCRIPTION	QUANTITY
A/1	60241	HIGH LIMIT-425 DEG CE SETTING	1
2	91635	STUD ASSY-PIVOT HI LIMIT BRKT	1
3	91624	WELD ASSY-HI LIMIT RESET PIN	1
4	74209	HOUSING-ELEMENT PIVOT	1
5	75819	PLATE-FRONT CAPILLARY	1
6	SC01-076	SCREW #8-32 X 1/4 PH THD	2
B/7	78484-005	ELEMENT-HEATING 7 KW 220V	1
8	78499	STRAP-SPREADER LVE10X	4
9	SC04-003	SCREW #8-32 X 3/8 PH PHD	6
10	91630	WELD ASSY-SPREADER SPLIT	2
11	91639	GUARD-SPLIT FRONT HI LIMIT	1
12	91641	GUARD-SPLIT REAR HI LIMIT	1
B/13	76964	GASKET-PIVOT HUB .015	1
14	75818	BRACKET-REAR CAPILLARY	1
15	75022	SCREW-REWORKED 3/8 SHOULDER	2
16	92393	BRACKET-HI-LIMIT MOUNTING	1
A/17	OR01-004	#8115 O-RING	2

Recommend Parts: A=Truck Stock, B=Dist. Stock

**4-12 ASSY- ELEMENT & HUB-FULL VAT**

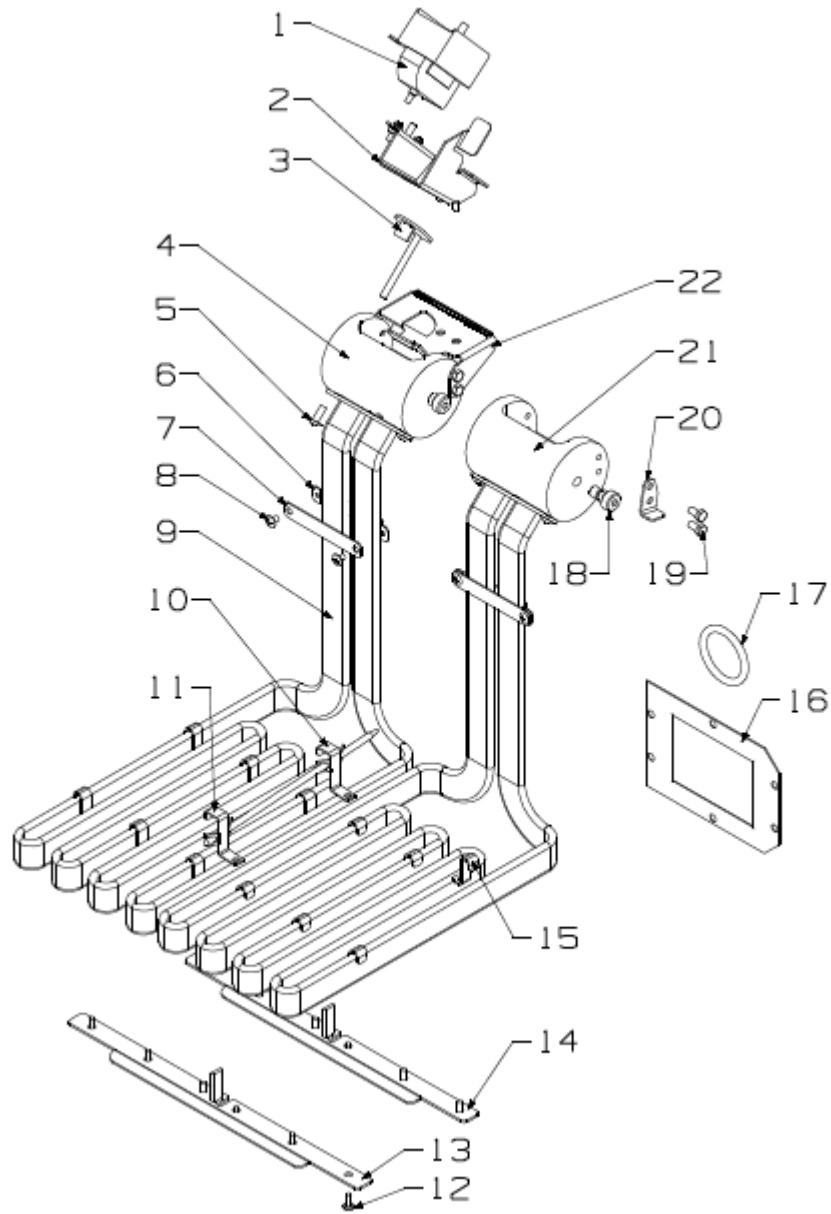



**4-12 ASSY- ELEMENT & HUB-FULL VAT**

ITEM	PART NUMBER	DESCRIPTION	QUANTITY
A/1	60241	HIGH LIMIT-425 DEG CE SETTING	1
2	91635	STUD ASSY-PIVOT HI LIMIT BRKT	1
3	91624	WELD ASSY-HI LIMIT RESET PIN	1
4	74209	HOUSING-ELEMENT PIVOT	1
5	SC01074	SCREW #10-32 X 1/2 PH THD	4
6	75818	BRACKET-REAR CAPILLARY	2
7	75819	PLATE-FRONT CAPILLARY	2
8	SC01-076	SCREW #8-32 X 1/4 PH THD	4
B/9	78484-005	ELEMENT-HEATING 7 KW 220V	2
10	78615	GUARD-FULL REAR HI LIMIT LVE	1
11	78614	GUARD-FULL FRONT HI LIMIT LVE	1
12	SC04-003	SCREW #8-32 X 3/8 PH PHD	12
13	92323	WELD ASSY-SPREADER FULL	1
14	92444	WELD ASSY-SPREADER FULL OFE142	1
15	78499	STRAP-SPREADER LVE10X	12
B/16	76964	GASKET-PIVOT HUB .015	2
A/17	OR01-004	#8115 O-RING	4
18	75022	SCREW-REWORKED 3/8 SHOULDER	4
19	SC01-084	SCREW #10-32 X 3/8 HEX HD	6
20	91599	HEATER LIMIT BRACKET	1
21	82459	HOUSING-ELEMENT PIVOT RH FULL	1
22	92393	BRACKET-HI-LIMIT MOUNTING	1

Recommend Parts: A=Truck Stock, B=Dist. Stock

**4-13 MOTOR AND PUMP**

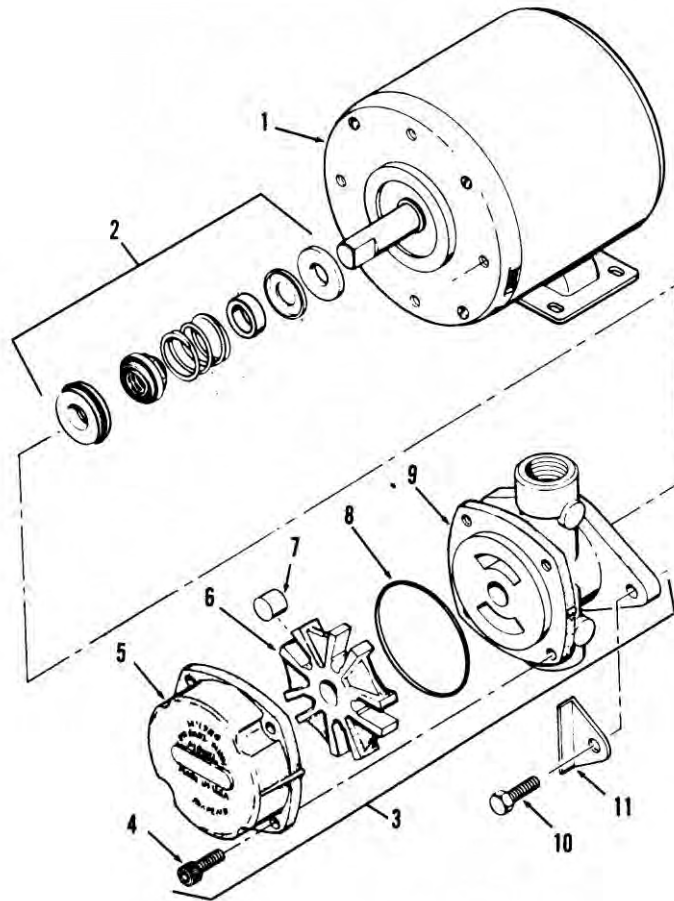

ITEM	PART NUMBER	DESCRIPTION	QUANTITY
A/1	89323	MOTOR, 1/2 HP - 50/60 H	1
A/2	17476	SEAL KIT	1
B/3	17437	PUMP ASSEMBLY	1
4	SC01-132	SCREW, Pump Cover	1
5	17451	COVER, Pump	1
B/6	17447	ROTOR, Pump	1
A/7	17446	ROLLER, Pump	5
A/8	17453	O-RING	1
9	17454	BODY, Pump	1
10	17456	SHIELD, Pump	2
11	SC01-026	SCREW, Pump Shield	1

Recommend Parts: A=Truck Stock, B=Dist. Stock

**4-14 GDS-ROD ASSY**

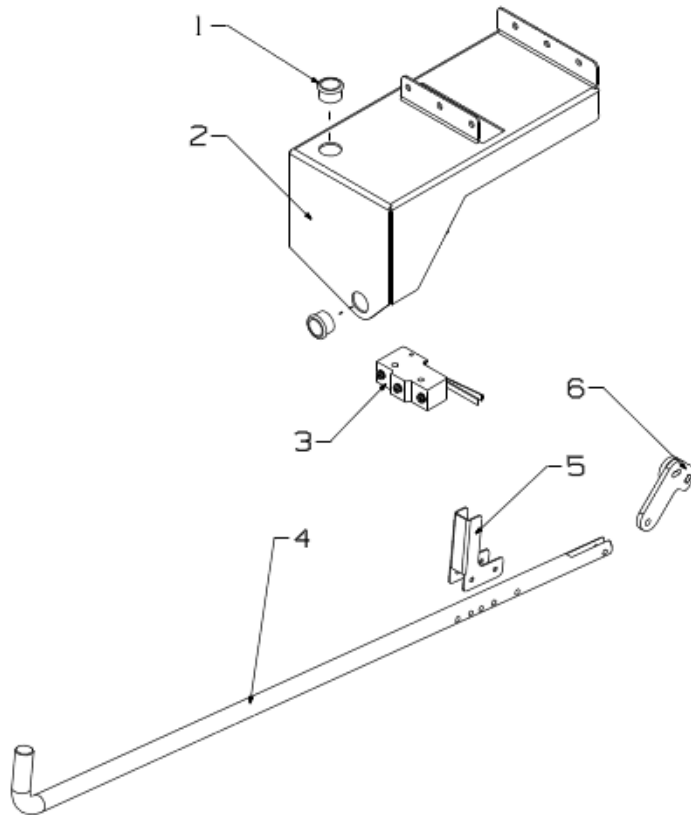

ITEM	PART NUMBER	DESCRIPTION	QUANTITY
1	EF02-106	BUSHING-SNAP 1/2 ID PLASTIC	2
2	93927	BRACE-MOTOR ROD SUPPORT	1
A/3	95757	MICROSWITCH-RIGID LEVER	1
4	95028	ROD B-MOTOR SWICH	1
5	95031	BOARD-LIMIT	1
6	93402	WELD ASSY-ROCKER	1

Recommend Parts: A=Truck Stock, B=Dist. Stock

**4-15 PIPING SYSTEM-OFE142 FULL VAT (PUMP VERTICAL)**

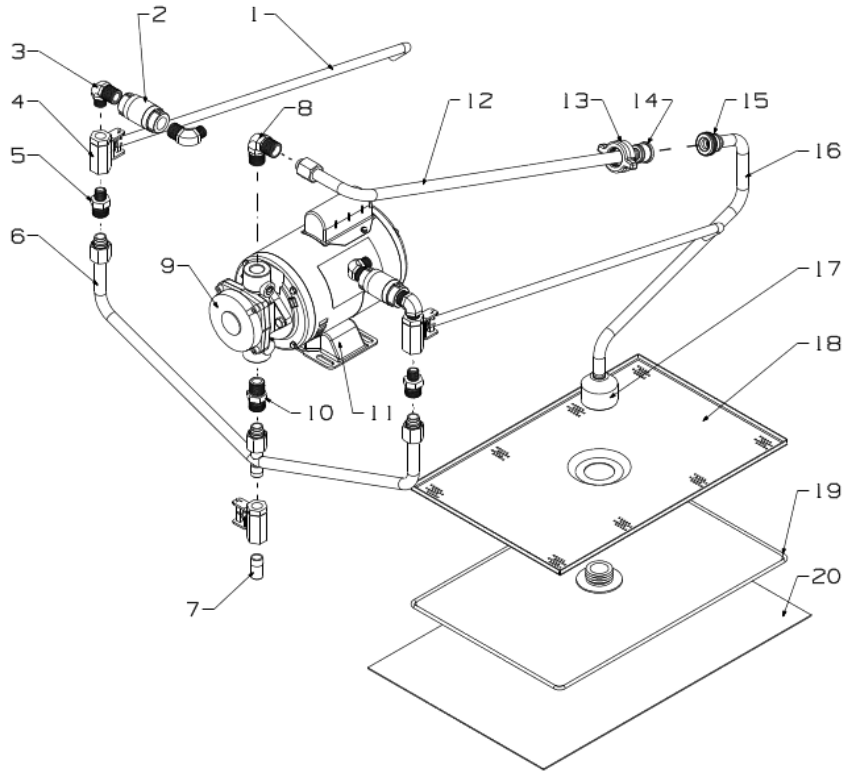

ITEM	PART NUMBER	DESCRIPTION	QUANTITY
1	92161	ROD-RETURN OPEN DRAIN OFE142	2
A/2	74469	VALVE-1/2 CHECK	2
3	93080	ELBOW 3/8NPT MALE-1/2NPT MALE	4
B/4	17308	VALVE FILTER	3
5	91231	FITTING CONNECTOR MALE	2
6	95645	WELD TUBE ASSY-VALVE TO POT	1
7	93023	0.5 NIPPLE-3/8 NPT X 1	1
8	17407	CONNECTOR 1/2 MALE ELBOW	1
B/9	17437	ASSY-SUB PUMP 5 GPM	1
10	16807	FITTING CONNECTOR MALE	1
A/11	89323	MOTOR-1/2 HP FILTER PUMP	1
12	96066	ASSY-TOP OIL RETURN	1
13	69288	UNION-HANDLE FITTING	1
14	69287	UNION-MALE FITTING	1
15	69286	UNION-FEMALE FITTING	1
16	96068	TUBE-PICK UP	1
17	65208	NUT-FILTER-FEMALE	1
18	65211	CRUMB CATCHER	1
19	89412	ASSY-FILTER SECTION-WELDMENT	1
20	12102	PHT FILTER ENVELOPES-100CT	1

Recommend Parts: A=Truck Stock, B=Dist. Stock

**4-16 PIPING SYSTEM-OFE142 FULL VAT (PUMP HORIZONTAL)**

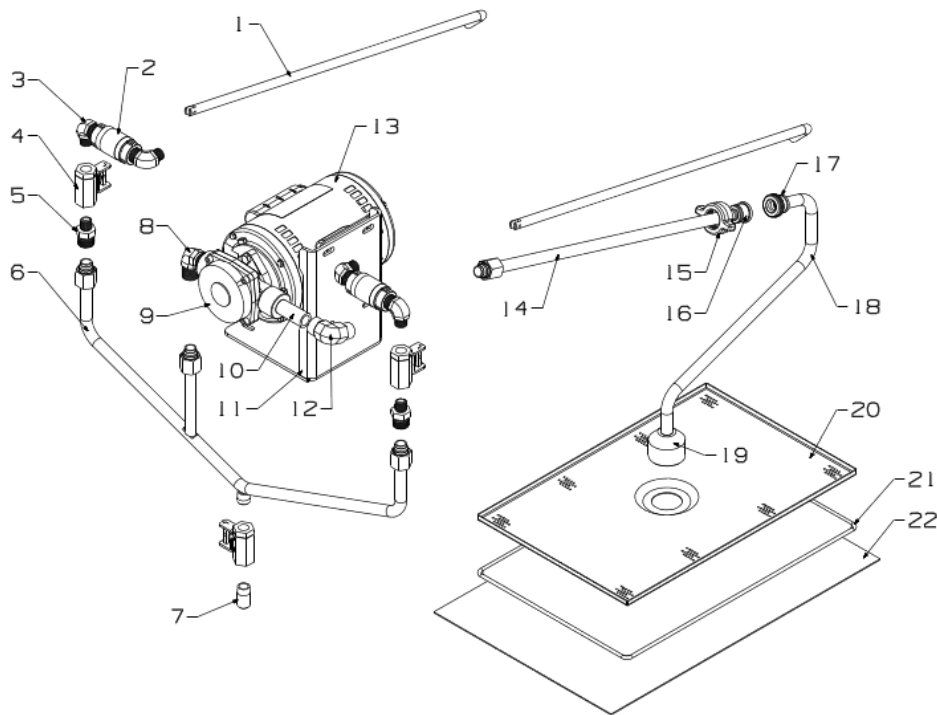

ITEM	PART NUMBER	DESCRIPTION	QUANTITY
1	92161	ROD-RETURN OPEN DRAIN OFE142	2
A/2	74469	VALVE-1/2 CHECK	2
3	93080	ELBOW 3/8NPT MALE-1/2NPT MALE	4
B/4	17308	VALVE FILTER	3
5	91231	FITTING CONNECTOR MALE	2
6	95645	WELD TUBE ASSY-VALVE TO POT	1
7	93023	0.5 NIPPLE-3/8 NPT X 1	1
B/8	17407	CONNECTOR 1/2 MALE ELBOW	1
9	17437	ASSY-SUB PUMP 5 GPM	1
10	151875	1/2NPT-TUBE	1
11	151894	SOLEPLATE-MOTOR	1
12	FP01-118	ELBOW-5/8 TUBE-1/2 NPT FEMALE	1
A/13	89323	MOTOR-1/2 HP FILTER PUMP	1
14	96066	ASSY-TOP OIL RETURN	1
15	69288	UNION-HANDLE FITTING	1
16	69287	UNION-MALE FITTING	1
17	69286	UNION-FEMALE FITTING	1
18	96068	TUBE-PICK UP	1
19	65208	NUT-FILTER-FEMALE	1
20	65211	CRUMB CATCHER	1
21	89412	ASSY-FILTER SECTION-WELDMENT	1
22	12102	PHT FILTER ENVELOPES-100CT	1

Recommend Parts: A=Truck Stock, B=Dist. Stock

**4-17 PIPING SYSTEM-OFE142 SPLIT VAT (PUMP VERTICAL)**

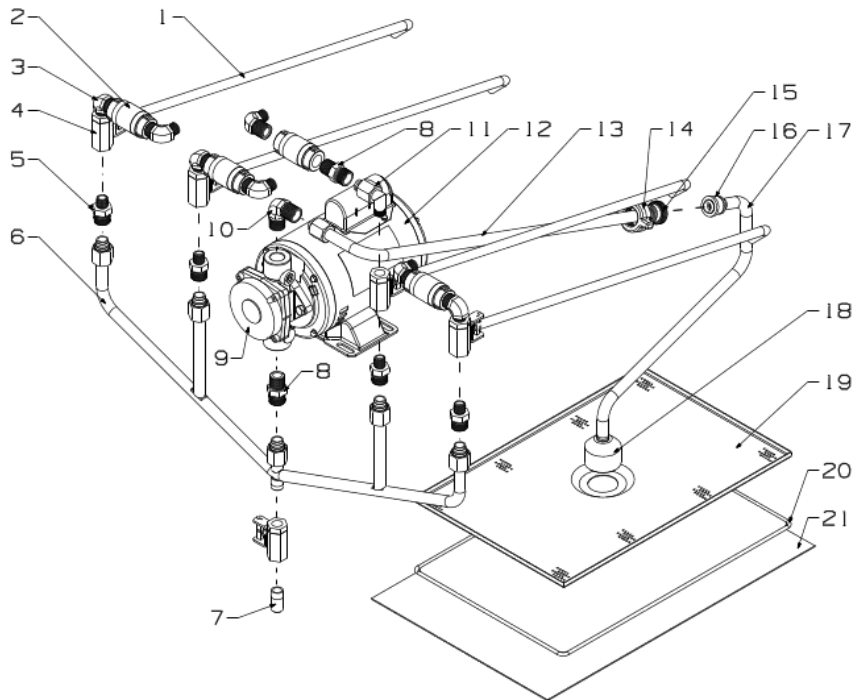

ITEM	PART NUMBER	DESCRIPTION	QUANTITY
1	92161	ROD-RETURN OPEN DRAIN OFE142	4
A/2	74469	VALVE-1/2 CHECK	4
3	93080	ELBOW 3/8NPT MALE-1/2NPT MALE	7
B/4	17308	VALVE FILTER	5
5	91231	FITTING CONNECTOR MALE	4
6	95897	WELD TUBE ASSY-VALVE TO POT	1
7	93023	0.5 NIPPLE-3/8 NPT X 1	1
8	16807	FITTING CONNECTOR MALE	2
B/9	17437	ASSY-SUB PUMP 5 GPM	1
10	17407	CONNECTOR 1/2 MALE ELBOW	1
11	93079	ASSY-TILT TUBE C	1
A/12	89323	MOTOR-1/2 HP FILTER PUMP	1
13	96066	ASSY-TOP OIL RETURN	1
14	69288	UNION-HANDLE FITTING	1
15	69286	UNION-MALE FITTING	1
16	69287	UNION-FEMALE FITTING	1
17	96068	TUBE-PICK UP	1
18	65208	NUT-FILTER-FEMALE	1
19	65211	CRUMB CATCHER	1
20	89412	ASSY-FILTER SECTION-WELDMENT	1
21	12102	PHT FILTER ENVELOPES-100CT	1

Recommend Parts: A=Truck Stock, B=Dist. Stock

**4-18 PIPING SYSTEM-OFE142 SPLIT VAT (PUMP HORIZONTAL)**

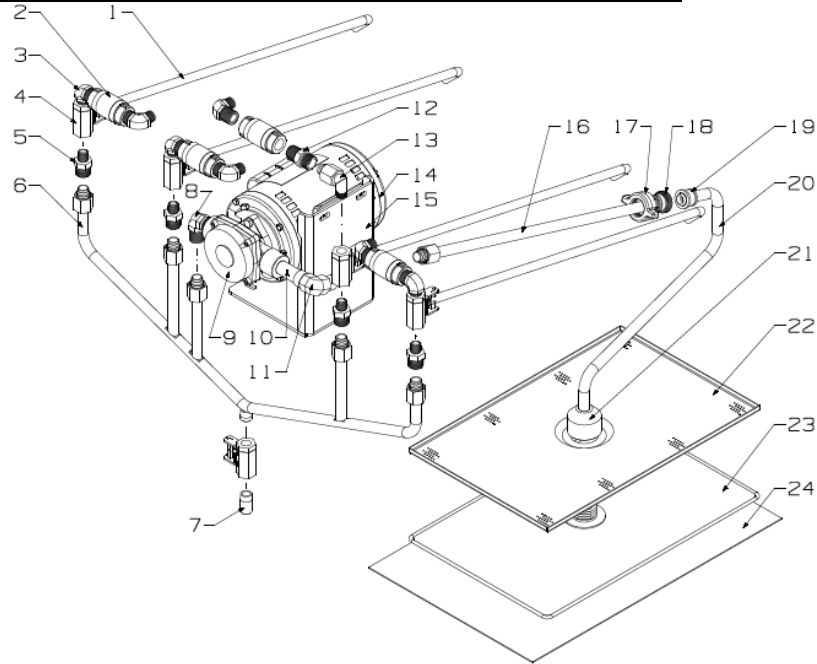

ITEM	PART NUMBER	DESCRIPTION	QUANTITY
1	92161	ROD-RETURN OPEN DRAIN OFE142	4
A/2	74469	VALVE-1/2 CHECK	4
3	93080	ELBOW 3/8NPT MALE-1/2NPT MALE	7
B/4	17308	VALVE FILTER	5
5	91231	FITTING CONNECTOR MALE	4
6	95897	WELD TUBE ASSY-VALVE TO POT	1
7	93023	0.5 NIPPLE-3/8 NPT X 1	1
8	17407	CONNECTOR 1/2 MALE ELBOW	1
B/9	17437	ASSY-SUB PUMP 5 GPM	1
10	151875	1/2NPT-TUBE	1
11	FP01-118	ELBOW-5/8 TUBE-1/2 NPT FEMALE	1
12	16807	FITTING CONNECTOR MALE	1
13	93079	ASSY-TILT TUBE C	1
A/14	89323	MOTOR-1/2 HP FILTER PUMP	1
15	151894	SOLEPLATE-MOTOR	1
16	96066	ASSY-TOP OIL RETURN	1
17	69288	UNION-HANDLE FITTING	1
18	69287	UNION-MALE FITTING	1
19	69286	UNION-FEMALE FITTING	1
20	96068	TUBE-PICK UP	1
21	65208	NUT-FILTER-FEMALE	1
22	65211	CRUMB CATCHER	1
23	89412	ASSY-FILTER SECTION-WELDMENT	1
24	12102	PHT FILTER ENVELOPES-100CT	1

Recommend Parts: A=Truck Stock, B=Dist. Stock

**4-19 PIPING SYSTEM-OFE141 SPLIT VAT (PUMP VERTICAL)**

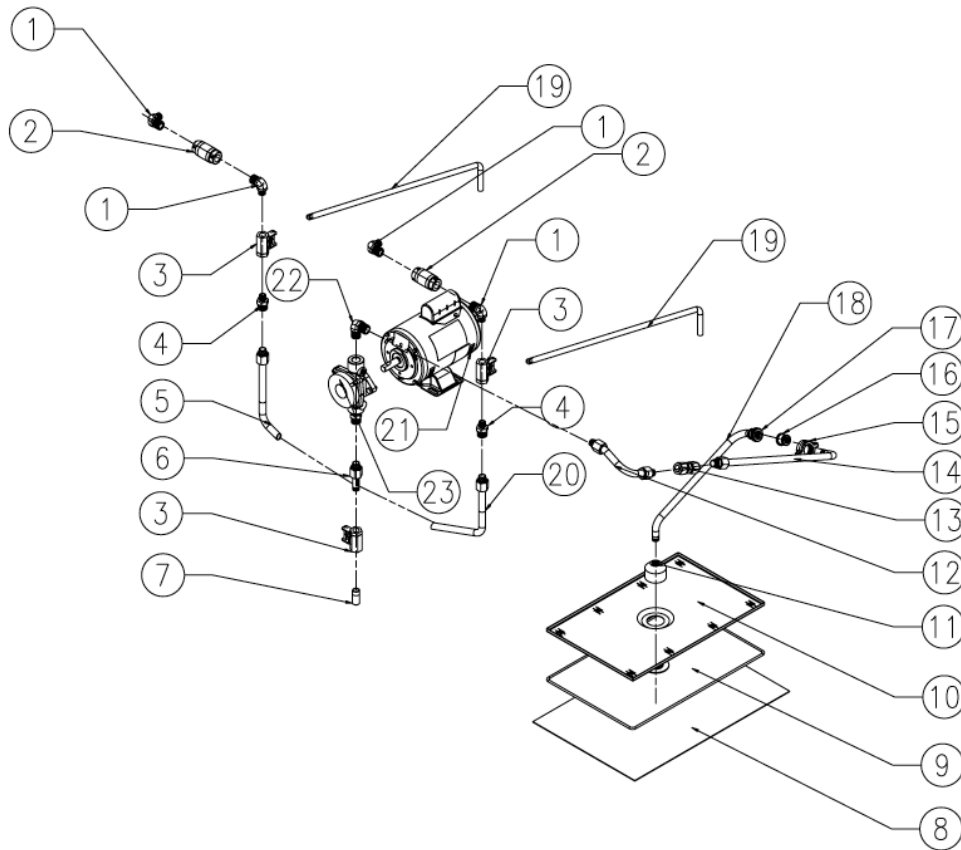

ITEM	PART NUMBER	DESCRIPTION	QUANTITY
A/1	93080	ELBOW 3/8NPT MALE-1/2NPT MALE	4
A/2	74469	VALVE-1/2 CHECK	2
B/3	17308	VALVE FILTER	3
4	91231	FITTING CONNECTOR MALE	2
5	93997	TUBE ASSY-ONE WAY TO PUMP R	1
6	93999	TUBE ASSY-PUMP TO V TUBE	1
7	93023	0.5 NIPPLE-3/8 NPT X 1SS	1
8	12102	FILTER ENVELOPE - CT OF 100	1
9	89412	ASSY-FILTER SECTION-WELDMENT	1
10	65211	CRUMB CATCHER	1
11	65208	NUT-FILTER-FEMALE	1
12	94702	TUPE A-PICK TO PUMP	1
13	FP01-202	CONNECTOR-5/8 TUBE TO 5/8 TUBE	1
14	94703	TUPE B-PICK TO PUMP	1
15	69288	UNION-HANDLE FITTING	1
16	69287	UNION-MALE FITTING	1
17	69286	UNION-FEMALE FITTING	1
18	93917	TUBE-PICK UP	1
19	91520	ROD-RETURN OPEN DRAIN OFE141	2
20	94000	TUBE ASSY-ONE WAY TO PUMP L	1
21	89323	MOTOR-1/2 HP FILTER PUMP	1
22	17407	CONNECTOR 1/2 MALE ELBOW	1
B/23	17437	PUMP SUBASSY 5GPM	1

Recommend Parts: A=Truck Stock, B=Dist. Stock



**4-20 PIPING SYSTEM-OFE141 SPLIT VAT (PUMP HORIZONTAL , SN: BF1509001Before)**

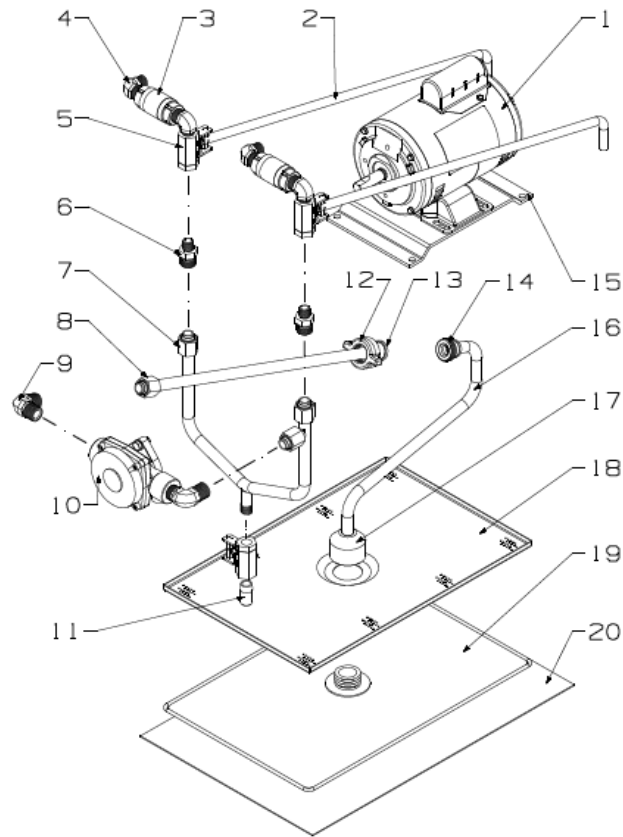

ITEM	PART NUMBER	DESCRIPTION	QUANTITY
A/1	89323	MOTOR-1/2 HP FILTER PUMP	1
2	91520	ROD-RETURN OPEN DRAIN OFE141	2
A/3	74469	VALVE-1/2 CHECK	2
4	93080	ELBOW 3/8NPT MALE-1/2NPT MALE	4
B/5	17308	VALVE FILTER	3
6	91231	FITTING CONNECTOR MALE	2
7	151899	WELD ASSY-POT TO PUMP	1
8	151919	TUBE ASSY-RETURN	1
9	17407	CONNECTOR 1/2 MALE ELBOW	2
B/10	17437	ASSY-SUB PUMP 5 GPM	1
11	93023	0.5 NIPPLE-3/8 NPT X 1 SS	1
12	69288	UNION-HANDLE FITTING	1
13	69287	UNION-MALE FITTING	1
14	69286	UNION-FEMALE FITTING	1
15	151917	BRACE-PUMP MOTOR MOUNTING	1
16	151918	TUBE-PICK UP	1
17	65208	NUT-FILTER-FEMALE	1
18	65211	CRUMB CATCHER	1
19	89412	ASSY-FILTER SECTION-WELDMENT	1
20	12102	PHT FILTER ENVELOPES-100CT	1

Recommend Parts: A=Truck Stock, B=Dist. Stock

**4-20 PIPING SYSTEM-OFE141 SPLIT VAT (PUMP HORIZONTAL SN: BF1509001&After)**

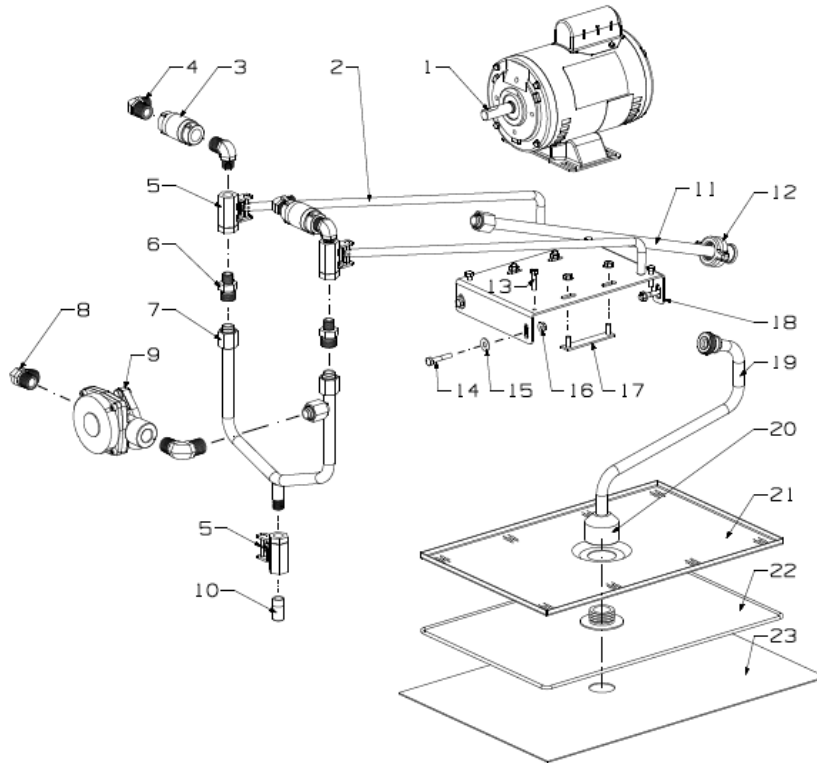

ITEM	PART NUMBER	DESCRIPTION	QUANTITY
A/1	89323	MOTOR-1/2 HP FILTER PUMP	1
2	91520	ROD-RETURN OPEN DRAIN OFE141	2
A/3	74469	VALVE-1/2 CHECK	2
4	93080	ELBOW 3/8NPT MALE-1/2NPT MALE	4
B/5	17308	VALVE FILTER	3
6	91231	FITTING CONNECTOR MALE	2
7	151899	WELD ASSY-POT TO PUMP	1
8	17407	CONNECTOR 1/2 MALE ELBOW	2
B/9	17437	ASSY-SUB PUMP 5 GPM	1
10	93023	0.5 NIPPLE-3/8 NPT X 1 SS	1
11	151919	TUBE ASSY-RETURN	1
12	69289	ASSY-FILTER UNION	1
13	SC01-039	SCREW 1/4-20 X 1 HEX HD	4
14	SC01-104	SCREW 1/4-20 X 1 1/2 HEX HD	4
15	WA01-002	WASHER 1/4 TYPE A-SERIES	4
16	NS04-005	SERRATED FLANGED LOCKNUT1/4-20	8
17	92930	STUD ASSY-PLATE PUMP MOUNTING	2
18	156093-002	FORM-BRACE-PUMP MOTOR MOUTNING	1
19	151918	TUBE-PICK UP	1
20	65208	NUT-FILTER-FEMALE	1
21	65211	CRUMB CATCHER	1
22	89412	ASSY-FILTER SECTION-WELDMENT	1
23	12102	PHT FILTER ENVELOPES-100CT	1

Recommend Parts: A=Truck Stock, B=Dist. Stock

**4-21 PIPING SYSTEM-OFE141 FULL VAT (PUMP VERTICAL)**

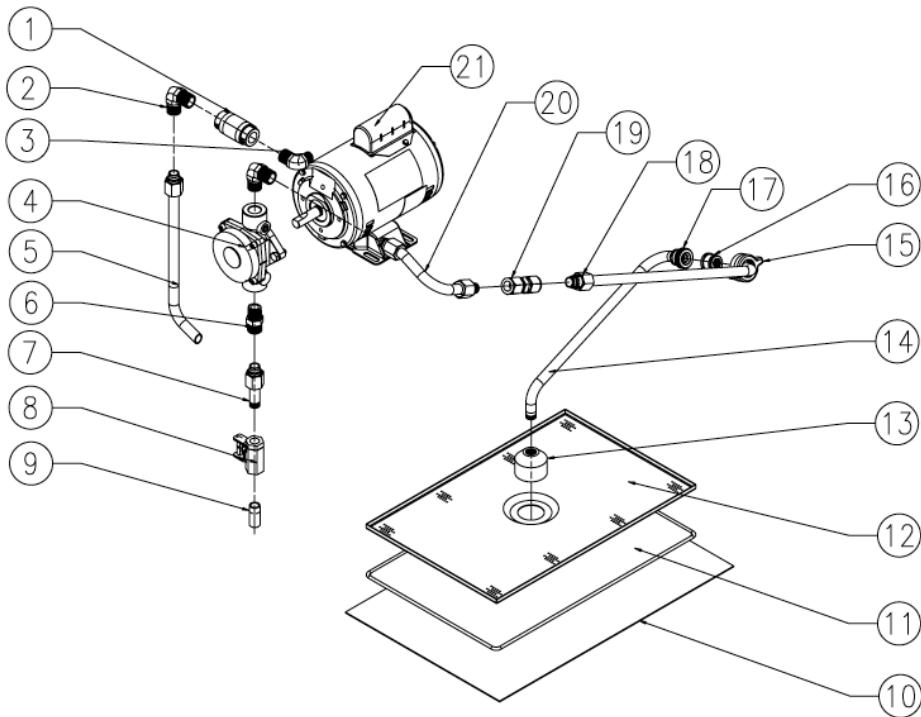

ITEM	PART NUMBER	DESCRIPTION	QUANTITY
A/1	74469	VALVE-1/2 CHECK	1
2	17407	CONNECTOR 1/2 MALE ELBOW	2
3	93080	ELBOW 3/8NPT MALE-1/2NPT MALE	1
4	17437	PUMP SUBASSY 5GPM	1
5	93890	TUBE ASSY-ONE WAY TO PUMP	1
6	16807	FITTING CONNECTOR MALE	1
7	93086	WELD ASSY-PUMP TO V TUBE	1
B/8	17308	VALVE FILTER	1
9	93023	0.5 NIPPLE-3/8 NPT X 1SS	1
10	12102	FILTER ENVELOPE - CT OF 100	1
11	89412	ASSY-FILTER SECTION-WELDMENT	1
12	65211	CRUMB CATCHER	1
13	65208	NUT-FILTER-FEMALE	1
14	93917	TUBE-PICK UP	1
15	69288	UNION-HANDLE FITTING	1
16	69287	UNION-MALE FITTING	1
17	69286	UNION-FEMALE FITTING	1
18	94703	TUPE B-PICK TO PUMP	1
19	FP01-202	CONNECTOR-5/8 TUBE TO 5/8 TUBE	1
20	94702	TUPE A-PICK TO PUMP	1
A/21	89323	MOTOR-1/2 HP FILTER PUMP	1

Recommend Parts: A=Truck Stock, B=Dist. Stock

**4-22 PIPING SYSTEM-OFE141 FULL VAT (PUMP HORIZONTAL , SN: BF1509001Before)**

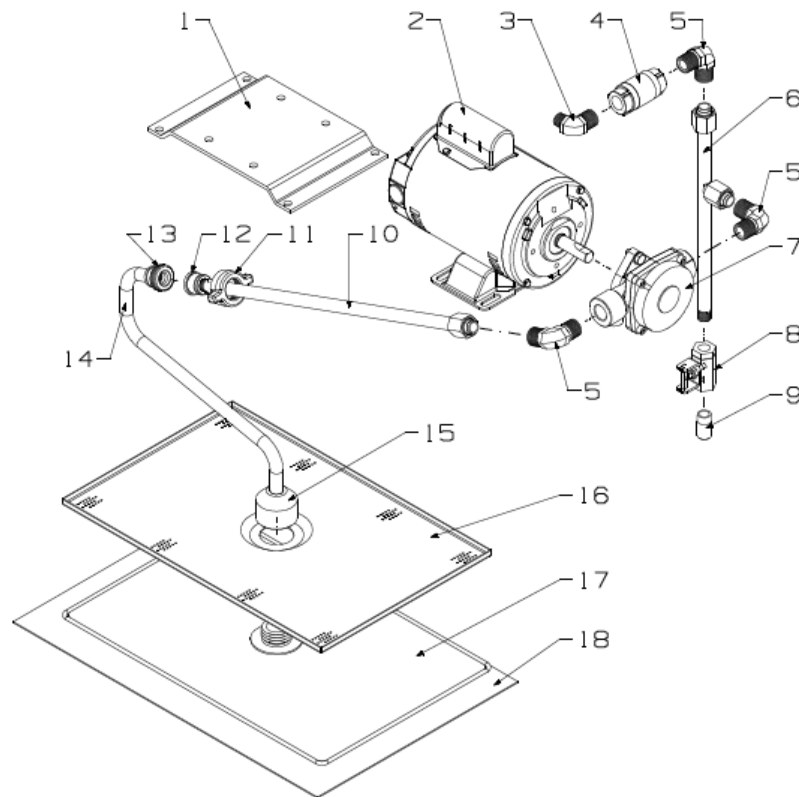

ITEM	PART NUMBER	DESCRIPTION	QUANTITY
1	151917	BRACE-PUMP MOTOR MOUNTING	1
A/2	89323	MOTOR-1/2 HP FILTER PUMP	1
3	93080	ELBOW 3/8NPT MALE-1/2NPT MALE	1
A4	74469	VALVE-1/2 CHECK	1
5	17407	CONNECTOR 1/2 MALE ELBOW	3
6	151950	WELD ASSY-POT TO PUMP	1
B/7	17437	ASSY-SUB PUMP 5 GPM	1
B/8	17308	VALVE FILTER	1
9	93023	0.5 NIPPLE-3/8 NPT X 1 SS	1
10	151919	TUBE ASSY-RETURN	1
11	69288	UNION-HANDLE FITTING	1
12	69287	UNION-MALE FITTING	1
13	69286	UNION-FEMALE FITTING	1
14	151917	BRACE-PUMP MOTOR MOUNTING	1
15	65208	NUT-FILTER-FEMALE	1
16	65211	CRUMB CATCHER	1
17	89412	ASSY-FILTER SECTION-WELDMENT	1
18	12102	PHT FILTER ENVELOPES-100CT	1

Recommend Parts: A=Truck Stock, B=Dist. Stock

**4-22 PIPING SYSTEM-OFE141 FULL VAT (PUMP HORIZONTAL , SN: BF1509001&After)**

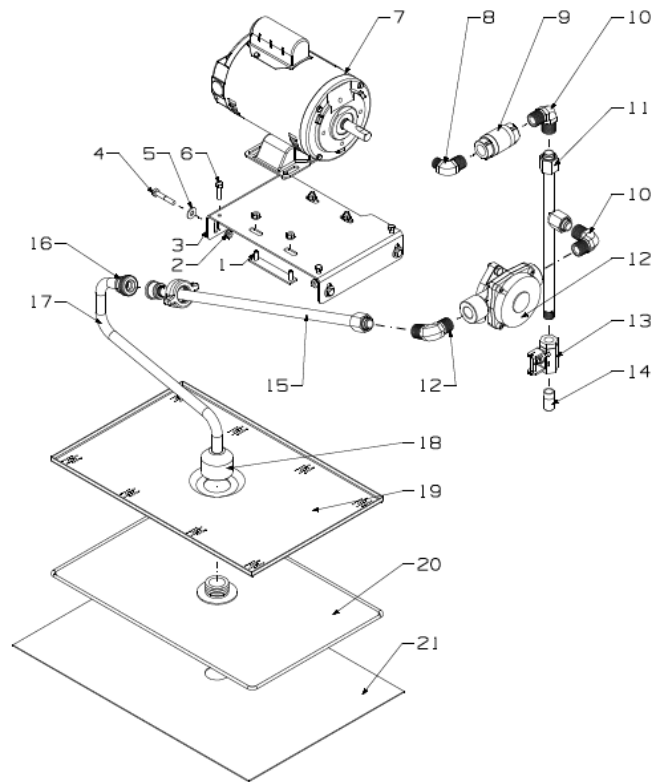

ITEM	PART NUMBER	DESCRIPTION	QUANTITY
1	92930	STUD ASSY-PLATE PUMP MOUNTING	2
2	NS04-005	SERRATED FLANGED LOCKNUT 1/4-20	8
3	156113-002	FORM-BRACE-PUMP MOTOR MOUNTING	1
4	SC01-039	SCREW 1/4-20 X 1 HEX HD	4
5	WA01-002	WASHER 1/4 TYPE A-SERIES	4
6	SC01-104	SCREW 1/4-20 X 1 1/2 HEX HD	4
A/7	89323	MOTOR-1/2 HP FILTER PUMP	1
8	93080	ELBOW 3/8NPT MALE-1/2NPT MALE	1
A/9	74469	VALVE-1/2 CHECK	1
10	17407	CONNECTOR 1/2 MALE ELBOW	3
11	151950	WELD ASSY-POT TO PUMP	1
B/12	17437	ASSY-SUB PUMP 5 GPM	1
B/13	17308	VALVE FILTER	1
14	93023	0.5 NIPPLE-3/8 NPT X 1 SS	1
15	151919	TUBE ASSY-RETURN	1
16	69289	ASSY-FILTER UNION	1
17	151918	TUBE-PICK UP	1
18	65208	NUT-FILTER-FEMALE	1
19	65211	CRUMB CATCHER	1
20	89412	ASSY-FILTER SECTION-WELDMENT	1
21	12102	PHT FILTER ENVELOPES-100CT	1

Recommend Parts: A=Truck Stock, B=Dist. Stock

**4-23 DOOR ASSY-OFE141**

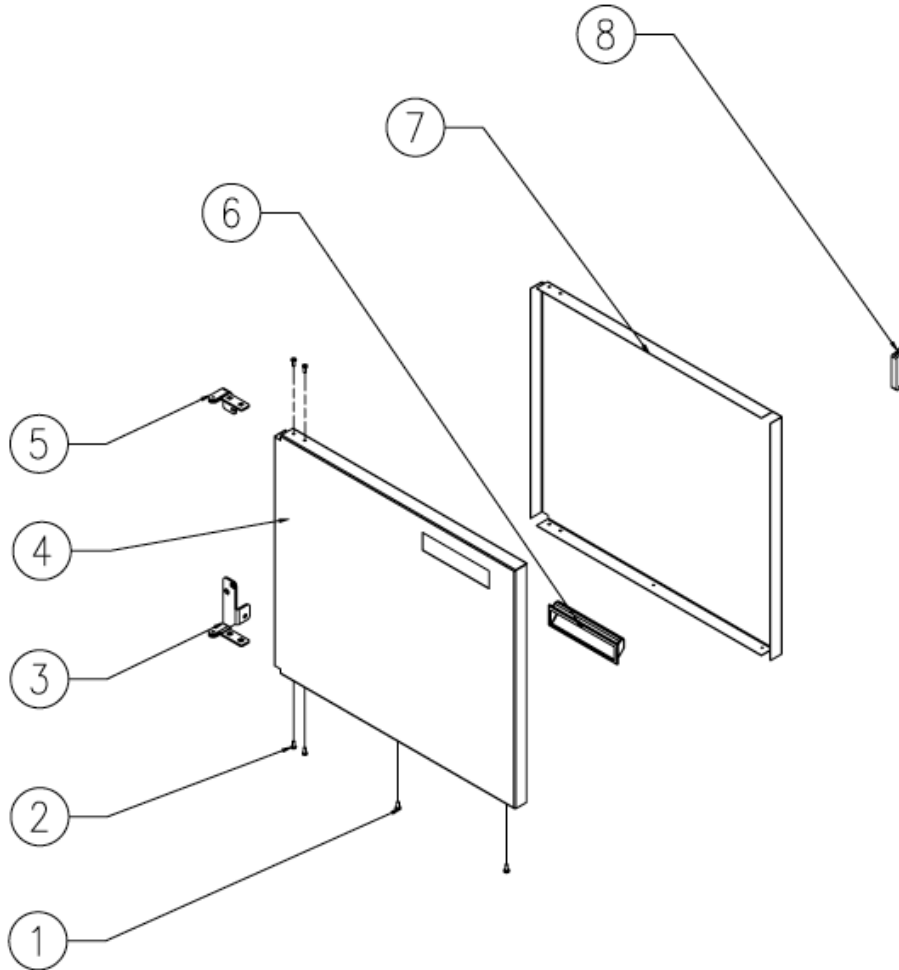

**Figure 4-4**

ITEM	PART NUMBER	DESCRIPTION	QUANTITY
1	SC04-003	SCREW #8-32 X 3/8 PH PHD S	2
2	SC01-049	SCREW #6-32 X 3/8 PH PHD C	4
3	21034	ASSY-HINGE BOTTOM	1
4	88699	PANEL-OUTER DOOR RH	1
5	17618	PANEL-INNER DOOR RH	1
6	41836	POCKET PULL	1
7	88698	PANEL-INNER DOOR RH	1
8	17002	MAGNET	1

**4-24 LH DOOR ASSY- OFE142**

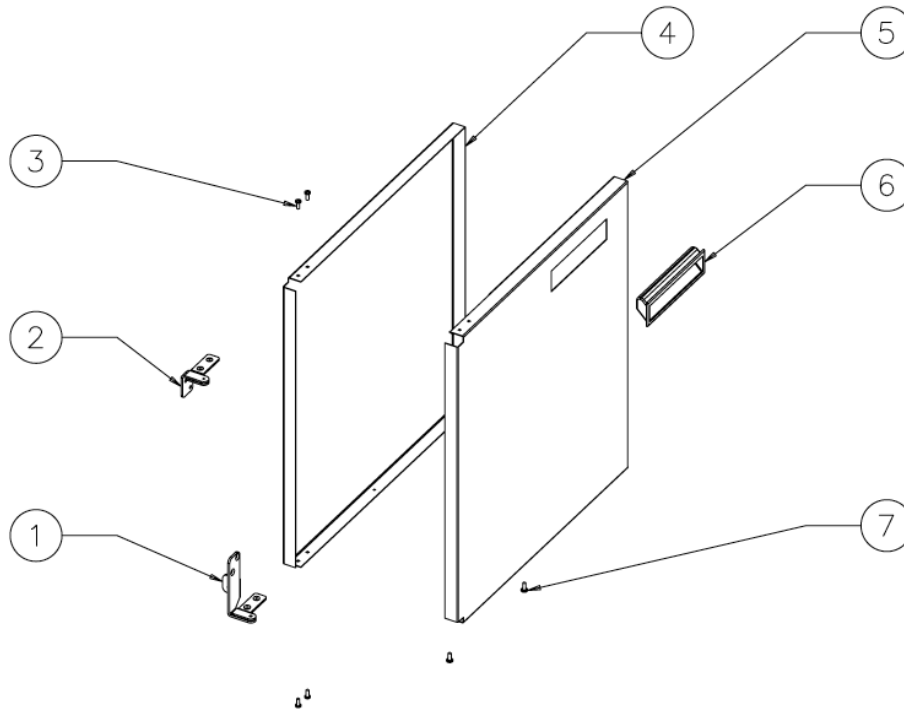

ITEM	PART NUMBER	DESCRIBE	QUANTITY
1	21034	BOTTOM HINGE ASSY	1
2	17618	TOP HINGE ASSY	1
3	SC01-049	SCREW #6-32 X 3/8 PH PHD C	4
4	84847	PANEL-INNER DOOR LH	1
5	84848	PANEL-OUTER DOOR LH	1
6	41836	POCKET PULL	1
7	SC04-003	SCREW #8-32 X 3/8 PH PHD S	2

**4-25 RH DOOR ASSY - OFE142**

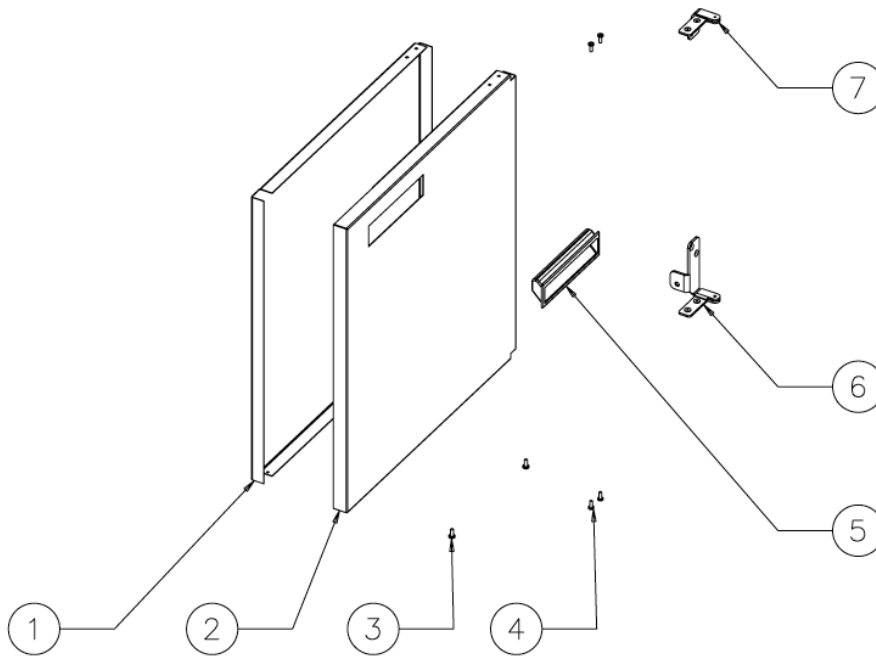

ITEM	PART NUMBER	DESCRIBE	QUANTITY
1	84849	PANEL-INNER DOOR RH	1
2	84850	PANEL-OUTER DOOR RH	1
3	SC04-003	SCREW #8-32 X 3/8 PH PHD S	2
4	SC01-049	SCREW #6-32 X 3/8 PH PHD C	4
5	41836	POCKET PULL	1
6	21433	BOTTOM HINGE ASSY-RH 342	1
7	17620	BOTTOM HINGE ASSY	1



**4-26 DRAIN PAN-OFE142 FULL VAT**

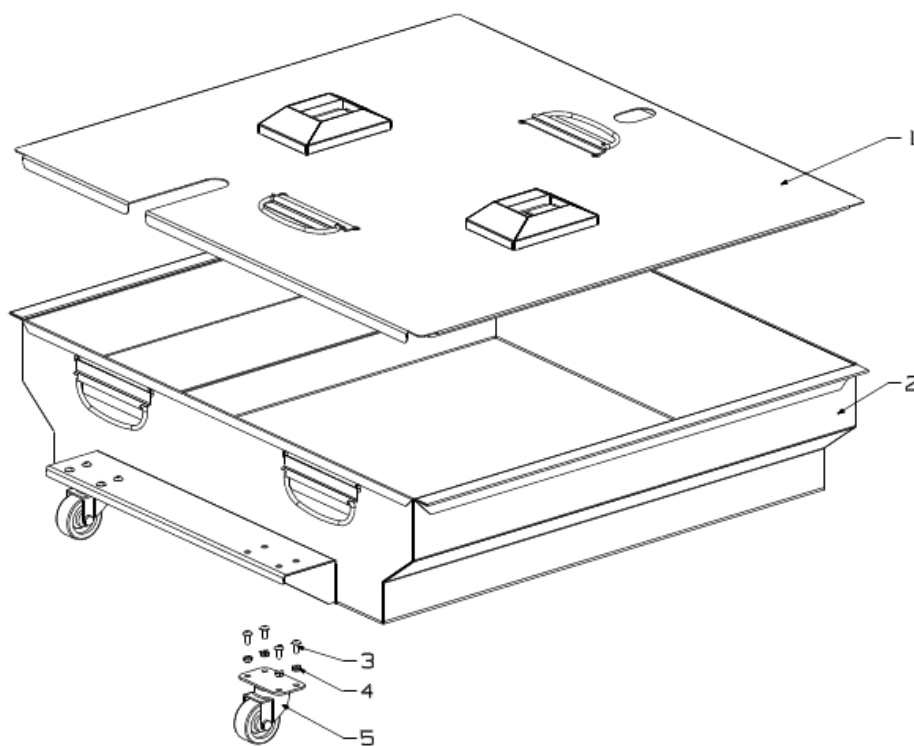

ITEM	PART NUMBER	DESCRIPTION	QUANTITY
1	155830	ASSY-DRAIN PAN COVER-142F	1
2	92163	WELD ASSY-DRAIN PAN-142F	1
3	SC01-074	SCREW #10-32 X 1/2 PH THD S	16
4	NS02-001	NUT HEX KEPS #10-32 C	16
5	19004	CASTER-2 IN SWIVEL MTG PLATE	4

**4-27 DRAIN PAN-OFE142 SPLIT VAT**

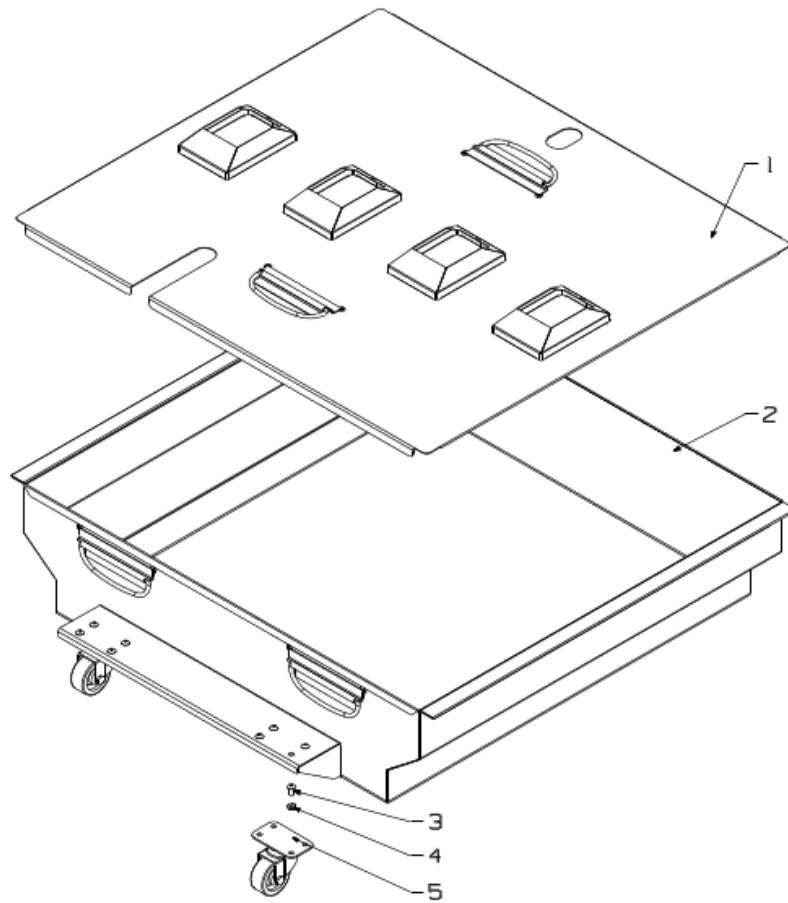

ITEM	PART NUMBER	DESCRIPTION	QUANTITY
1	155899	ASSY- DRAIN PAN COVER	1
2	92163	WELD ASSY-DRAIN PAN-142F	1
3	SC01-074	SCREW #10-32 X 1/2 PH THD S	16
4	NS02-001	NUT HEX KEPS #10-32 C	16
5	19004	CASTER-2 IN SWIVEL MTG PLATE	4

**4-28 ACCESSORY**

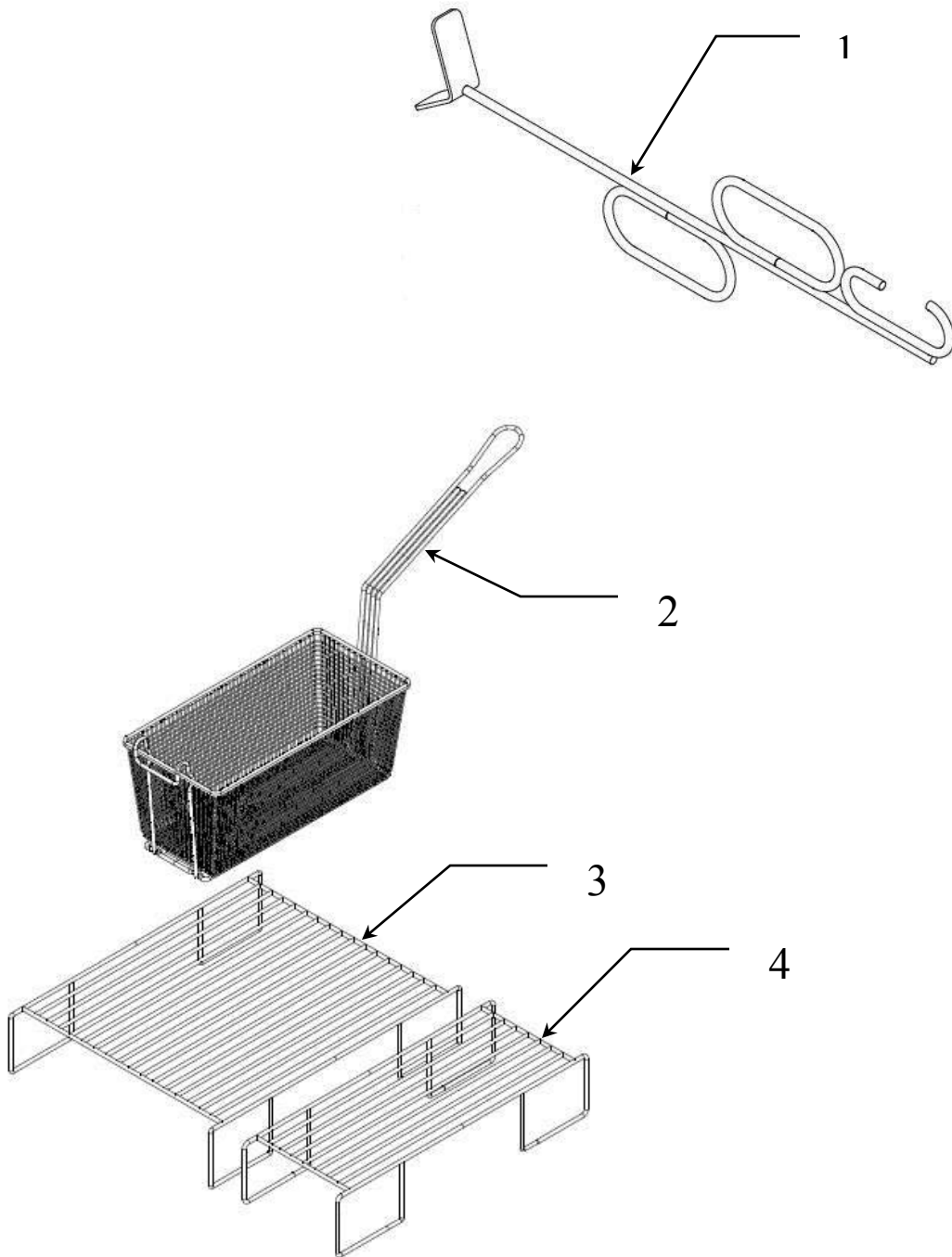

ITEM	PART NUMBER	DESCRIPTION	QUANTITY
B/1	74725	HANDLE-ELEMENT LIFT-LVE10X	1
B/2	92476	BASKET - HALF	2/FULL , 1/SPLIT
B/3	88521	SUPPORT-FRY BASKET	1/FULL VAT
B/4	91142	SUPPORT-FRY BASKET OFE141	1/SPLIT VAT

Recommend Parts: A=Truck Stock, B=Dist. Stock

## SECTION 5. TROUBLESHOOTING

### 5-1. TROUBLESHOOTING GUIDE

<b>Problem</b>	<b>Cause</b>	<b>Correction</b>
POWER switch ON but fryer completely inoperative	<ul style="list-style-type: none"> <li>• Open circuit</li> </ul>	<ul style="list-style-type: none"> <li>• Plug fryer in</li> <li>• Check breaker or fuse at supply box</li> </ul>
Shortening will not heat but lights are on	<ul style="list-style-type: none"> <li>• Open high limit</li> <li>• circuit</li> </ul>	<ul style="list-style-type: none"> <li>• Reset high limit per</li> <li>• Drain valve open</li> <li>• Turn drain valve handle to closed Position</li> </ul>
Foaming or boiling of shortening	<ul style="list-style-type: none"> <li>• Water in shortening</li> <li>• Improper or bad shortening</li> <li>• Improper filtering</li> <li>• Improper rinsing after cleaning the fryer</li> </ul>	<ul style="list-style-type: none"> <li>• At end of cook cycle, drain shortening and clean</li> <li>• Use recommended shortening</li> <li>• Refer to the procedure covering filtering the shortening</li> <li>• Clean and rinse the frypot, then dry thoroughly</li> </ul>
Shortening will not drain from frypot	<ul style="list-style-type: none"> <li>• Drain valve clogged with crumbs</li> </ul>	<ul style="list-style-type: none"> <li>• Open valve, force cleaning brush through drain</li> </ul>
Filter switch ON but motor does not run	<ul style="list-style-type: none"> <li>• Motor thermal protector tripped</li> </ul>	<ul style="list-style-type: none"> <li>• Reset thermal switch per section on Filter Pump Motor Protector – Manual Reset</li> </ul>

Or detailed troubleshooting information is available in the Technical Manual, available at [www.hennypenny.com](http://www.hennypenny.com), or 0512-89180262 or 1-800-417-8405 , 1-937-456-8405

**5-2. ERROR CODES** In the event of a control system failure, the digital display shows an error message. The message codes are shown in the DISPLAY column below. A constant tone is heard when an error code is displayed, and to silence this tone, press any button.

DISPLAY	CAUSE	PANEL BOARD CORRECTION
“E-4”	Control board overheating	Turn switch to OFF position, then turn switch back to ON; if display shows “E-4”, the control board is getting too hot; check the louvers on each side of the unit for obstructions
“E-5”	Shortening overheating	Turn switch to OFF position, then turn switch back to ON; if display shows “E-5”, the heating circuits and temperature probe should be checked
“E-6A”	Temperature probe open	Turn switch to OFF position, then turn switch back to ON; if display shows “E-6A”, the temperature probe should be checked; to replace, refer to Technical Manual
“E-6B”	Temperature probe shorted	Turn switch to OFF position, then turn switch back to ON; if display shows “E-6B”, the temperature probe should be checked; to replace, refer to Technical Manual
“E-10”	High limit	Reset the high limit by manually pushing up on the red reset button; if high limit does not reset, high limit must be replaced; refer to Technical Manual
“E-15”	Drain switch failure	Close drain, using the drain valve handle. If display still shows “E-15”, check the drain microswitch; refer to Technical Manual
“E-41”, “E-46”	Programming failure	Turn switch to OFF, then back to ON; if display shows any of the error codes, try to reinitialize the control (Special Program Mode section); if error code persists, replace the control board; refer to Technical Manual
“E-31”	Fan switch jumper wire missing or disconnected	Turn switch to OFF, then back to ON; if “E-31” persists, have jumper wires J2 & J4 on the 12-pin connectors on the PC board; if jumpers are OK, have PC board replaced
“E-54”	Faulty PC board component	Turn switch to OFF, then back to ON; if “E-54” persists, have PC board replaced
“E-70”	Faulty power switch, or switch wiring; faulty I/O board	Have POWER switch checked, along with its wiring. Have Input/Output board replaced if necessary