



**Henny Penny  
Open Fryer-Gas**

**Model OFG-391**

**TECHNICAL MANUAL**



## NOTICE

This manual should be retained in a convenient location for future reference.

A wiring diagram for this appliance is located on the rear shroud cover of the control panel.

Post in a prominent location, instructions to be followed if user smells gas. This information should be obtained by consulting the local gas supplier.

Do not obstruct the flow of combustion and ventilation air. Adequate clearance must be left all around appliance for sufficient air to the combustion chamber.

The Model OFG-390 open fryer is equipped with a continuous pilot. But fryer can not be operated with out electric power. Fryer will automatically return to normal operation when power is restored.

## CAUTION

*Keep appliance area free and clear from combustibles.*



**Improper installation, adjustment, alteration, service or maintenance can cause property damage, injury or death. Read the installation, operating and maintenance instructions thoroughly before installing or servicing this equipment.**



**DO NOT STORE OR USE GASOLINE OR OTHER FLAMMABLE VAPORS AND LIQUIDS IN THE VICINITY OF THIS OR ANY OTHER APPLIANCE. FIRE OR EXPLOSION COULD RESULT.**

# HENNY PENNY 8 HEAD GAS OPEN FRYER

## SPECIFICATIONS

Height	61" (155 cm)
Width	24" (61 cm)
Depth	41¾" ( 107 cm)
Floor Space	Approximately 7 sq. ft. (.65 sq. m.)
Pot Capacity	8 Head of chicken - 20 lbs. (9 kg.) 130 lbs. shortening (46 Kg.)
Electrical	120 VAC, 1 Phase, 50/60 Hz, 10 Amp, 2 Wire + Ground 230 VAC, 1 Phase, 50/60 Hz, 5 Amp, 2 Wire + Ground
Heating	Propane or Natural Gas; 100,000 BTU/Hr.(29.3 kw)
Shipping Weight	Approximately 670 lbs. (304 kg.)

## NOTICE

A data plate, located on the back shroud behind the lid, gives the information of the type of fryer, serial number, warranty date, and other information pertaining to fryer. Also, the serial number is stamped on the outside of the frypot. See figure below.

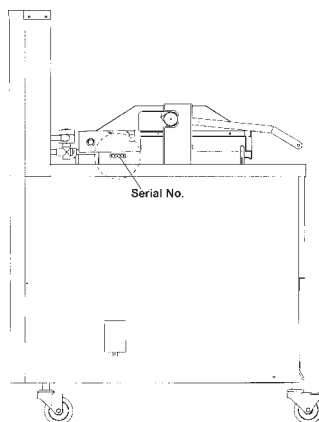

**TABLE OF CONTENTS**

<b>Section</b>	<b>Page</b>
Section 1. TROUBLESHOOTING .....	1-1
1-1 Introduction .....	1-1
1-2 Safety .....	1-1
1-3 Troubleshooting .....	1-2
1-4 Error Codes .....	1-11
Section 2. MAINTENANCE .....	2-1
2-1 Introduction .....	2-1
2-2 Maintenance Hints .....	2-1
2-3 Preventive Maintenance .....	2-1
2-4 High Limit Temperature Control .....	2-2
2-5 Power/Pump Switch .....	2-4
2-6 Temperature Probe Replacement .....	2-5
2-7 Complete Control Panel - Henny Penny .....	2-6
2-8 Lid Couterweight Cables .....	2-7
2-9 Gas Control Valve .....	2-9
2-10 Blower Assembly .....	2-11
2-11 Transformer .....	2-12
2-12 Airflow Switch .....	2-13
2-13 Drain Microswitch .....	2-14
2-14 Drain Valve and Extension .....	2-15
2-15 Air Valve .....	2-16
2-16 Cleaning the Dilution Box .....	2-17
2-17 Cleaning the Blower Wheel .....	2-17
2-18 Ignition Modules .....	2-18
2-19 Ignitor Assembly .....	2-19
2-20 Flame Sensor Assembly .....	2-20
2-21 Ignitor and Flame Sensor Adjustment .....	2-20
2-22 Nylatron Strips Replacement .....	2-20
2-23 Lubricating Lid Rollers .....	2-22
120 Volt Wiring Diagram .....	2-23
208-240 Volt Wiring Diagram .....	2-24
230 Volt Wiring Diagram .....	2-25
Section 3. PARTS INFORMATION .....	3-1
3-1 Introduction .....	3-1
3-2 Genuine Parts .....	3-1
3-3 How To Order .....	3-1
3-4 Prices .....	3-1
3-5 Delivery .....	3-1
3-6 Warranty .....	3-1
3-7 Recommended Spare Parts for Distributors .....	3-1



## SECTION 1. TROUBLESHOOTING

### 1-1. INTRODUCTION

This section provides troubleshooting information in the form of an easy to read table.

If a problem occurs during the first operation of a new fryer, recheck the installation per the Installation Section of this manual.

Before troubleshooting, always recheck the operation procedures per Section 3 of the Operator's Manual.

### 1-2. SAFETY

Where information is of particular importance or safety related, the words DANGER, WARNING, CAUTION, and NOTICE are used. Their usage is described below.



SAFETY ALERT SYMBOL is used with DANGER, WARNING, or CAUTION which indicates a personal injury type hazard.



NOTICE is used to highlight especially important information.



*CAUTION used without the safety alert symbol indicates a potentially hazardous situation which, if not avoided, may result in property damage.*



*CAUTION indicates a potentially hazardous situation which, if not avoided, may result in minor or moderate injury.*



**WARNING** indicates a potentially hazardous situation which, if not avoided, could result in death or serious injury.



**DANGER INDICATES AN IMMINENTLY HAZARDOUS SITUATION WHICH, IF NOT AVOIDED, WILL RESULT IN DEATH OR SERIOUS INJURY.**

### **1-3. TROUBLESHOOTING**

To isolate a malfunction, proceed as follows:

1. Clearly define the problem (or symptom) and when it occurs.
2. Locate the problem in the Troubleshooting table.
3. Review all possible causes. Then, one-at-a-time work through the list of corrections until the problem is solved.
4. Refer to the maintenance procedures in the Maintenance Section to safely and properly make the checkout and repair needed.



**If maintenance procedures are not followed correctly, injuries and/or property damage could result.**



Problem	Cause	Correction
<b>COOKING SECTION</b>		
Product color not correct: A. Too dark	<ul style="list-style-type: none"> <li>• Temperature too high</li> <li>• Faulty temperature probe</li> <li>• Shortening too old</li> <li>• Shortening too dark</li> <li>• Breading product too far in advance</li> </ul>	<ul style="list-style-type: none"> <li>• Check temperature setting in the program mode; see section on programming</li> <li>• Remove and replace temperature probe</li> <li>• Change shortening</li> <li>• Filter shortening</li> <li>• Change shortening</li> <li>• Bread product closer to actual frying period</li> </ul>
B. Too light	<ul style="list-style-type: none"> <li>• Temperature too low</li> <li>• Fryer incorrect preheat</li> <li>• Slow fryer heat-up/recovery</li> <li>• Wrong cook button pushed</li> </ul>	<ul style="list-style-type: none"> <li>• Check temperature setting</li> <li>• Remove and replace probe</li> <li>• Allow proper preheat time</li> <li>• Check gas pressure and blower airflow</li> <li>• Be sure to select the correct product to be cooked</li> </ul>
C. Product greasy	<ul style="list-style-type: none"> <li>• Shortening old</li> <li>• Temperature too low</li> <li>• Faulty temperature probe</li> <li>• Frypot overloaded</li> <li>• Product not removed from frypot immediately after end of cycle</li> </ul>	<ul style="list-style-type: none"> <li>• Replace shortening</li> <li>• Check temperature setting</li> <li>• Temperature not recovered when product was dropped in frypot</li> <li>• Remove and replace defective temperature probe</li> <li>• Reduce cooking load</li> <li>• Remove product from frypot immediately after end of cycle</li> </ul>

Problem	Cause	Correction
<b>COOKING SECTION (Continued)</b>		
D. Spotted product	<ul style="list-style-type: none"> <li>• Improper separation of the product</li> <li>• Breading not uniform on the product</li> <li>• Burned breading particles on product</li> <li>• Product sticking together</li> </ul>	<ul style="list-style-type: none"> <li>• Load product into basket properly</li> <li>• Sift breading regularly.</li> <li>• Separate product during breading</li> <li>• Filter the shortening more frequently</li> <li>• Separate product prior to cooking</li> </ul>
E. Dryness of product	<ul style="list-style-type: none"> <li>• Moisture loss prior to cooking</li> <li>• Overcooking the product</li> <li>• Wrong cook button pushed</li> </ul>	<ul style="list-style-type: none"> <li>• Use fresh products</li> <li>• Reduce cooking time.</li> <li>• Reduce cooking temperature</li> <li>• Be sure to select the correct product to be cooked</li> </ul>
Product flavor (taste): A. Salty taste	<ul style="list-style-type: none"> <li>• Breading mixture is too salty</li> <li>• Incorrect choice of breading</li> </ul>	<ul style="list-style-type: none"> <li>• Sift breading after each use</li> <li>• Incorrect breading mixture</li> <li>• Discard old breading</li> <li>• Use breading designed for the desired product</li> </ul>
B. Burned taste	<ul style="list-style-type: none"> <li>• Burned shortening favor</li> <li>• Frypot not properly cleaned</li> </ul>	<ul style="list-style-type: none"> <li>• Replace shortening</li> <li>• Drain and clean frypot</li> </ul>
C. Bland taste	<ul style="list-style-type: none"> <li>• Raw product not fresh</li> <li>• Breading mixture incorrect for product (spice content too low)</li> <li>• Cooking temperature too high (spice flavors lost)</li> </ul>	<ul style="list-style-type: none"> <li>• Use fresh raw product</li> <li>• Use breading designed for desired product</li> <li>• Check temperature</li> </ul>

Problem	Cause	Correction
<b>COOKING SECTION (Continued)</b>		
D. Rancid taste	<ul style="list-style-type: none"> <li>• Shortening too old</li>   <li>• Infrequent filtering</li>   <li>• Non-compatible products cooked within the same shortening</li>   <li>• Raw product not fresh</li> </ul>	<ul style="list-style-type: none"> <li>• Replace shortening, and follow recommended care and use of shortening</li>   <li>• Replace shortening and follow recommended care and use of shortening</li>   <li>• Replace shortening</li> <li>• Use compatible products, and follow recommended care and use of shortening</li>   <li>• Use fresh product</li> </ul>
General: A. Meat separation from bone	<ul style="list-style-type: none"> <li>• Incorrect meat cut</li>   <li>• Overcooking</li>   <li>• Product not fresh</li> </ul>	<ul style="list-style-type: none"> <li>• Use correct meat cutting procedures</li>   <li>• Check cooking time</li>   <li>• Use fresh product</li> </ul>
B. Bone color not proper	<ul style="list-style-type: none"> <li>• Using frozen product (black bone)</li>   <li>• Improper processing of product (black bone)</li>   <li>• Product not thoroughly cooked (red bone)</li> </ul>	<ul style="list-style-type: none"> <li>• Use fresh product</li>   <li>• Use proper processing procedure for product</li>   <li>• Check cooking time</li> <li>• Check cooking temperature</li> </ul>
C. Breading falls off	<ul style="list-style-type: none"> <li>• Incorrect breading procedures</li>   <li>• Product partially frozen</li> </ul>	<ul style="list-style-type: none"> <li>• Use correct breading procedure</li>   <li>• Thoroughly thaw the product, before breading</li> </ul>
D. Product sticking together	<ul style="list-style-type: none"> <li>• Product breaded too long prior to cooking</li>   <li>• Improper loading procedure</li>   <li>• Wrong cook button pushed. correct amount of product</li> </ul>	<ul style="list-style-type: none"> <li>• Refer to breading and frying instructions</li>   <li>• Properly load product per loading procedures</li>   <li>• Be sure to select the to be cooked</li> </ul>

Problem	Cause	Correction
<b>POWER SECTION</b>		
<p>With switch in POWER position, the fryer is completely inoperative (no power)</p>	<ul style="list-style-type: none"> <li>• Open circuit</li> </ul>	<ul style="list-style-type: none"> <li>• Check to see that unit is plugged in</li> <li>• Check the breaker or fuse at supply box</li> <li>• Check voltage at wall receptacle</li> <li>• Check COOK/PUMP switch; replace if defective</li> <li>• Check cord and plug</li> </ul>

Problem	Cause	Correction
<b>HEATING OF SHORTENING SECTION</b>		
Shortening will not heat	<ul style="list-style-type: none"> <li>• Gas valve knob turned to the OFF position</li> <li>• Blown fuse or tripped circuit breaker at supply box or control panel</li> <li>• Blown fuse in PC board</li> <li>• Faulty POWER/PUMP switch</li> <li>• Faulty cord and plug</li> <li>• Faulty drain switch</li> <li>• Faulty PC board</li> <li>• Faulty high limit control switch</li> <li>• Drain valve open</li> <li>• Possible faulty gas control valve</li> <li>• Possible faulty temperature probe</li> <li>• Bad spark ignitor</li> <li>• Low air pressure</li> <li>• Faulty ignitor module</li> <li>• Spark ignitor or flame sensor out of adjustment</li> </ul>	<ul style="list-style-type: none"> <li>• Make sure the gas valve knob is turned to the ON position.</li> <li>• Reset breaker or replace fuse</li> <li>• Replace glass fuse in board</li> <li>• Check COOK/PUMP switch per COOK/PUMP Switch Section</li> <li>• Check cord and plug and power at wall receptacle</li> <li>• Check drain switch per Drain Switch Section</li> <li>• Remove and replace control panel</li> <li>• Check high limit control switch per High Temperature Limit Section</li> <li>• Close drain valve</li> <li>• With power removed from fryer, check across electrical leads of gas valve with multimeter, and gas valve on ON position</li> <li>• Replace temperature probe</li> <li>• Replace spark ignitor</li> <li>• Clean or replace blower</li> <li>• Replace air pressure switch</li> <li>• Replace ignitor module</li> <li>• The spark ignitor needs to be 1/8 in. from the pilot hood, and the flame sensor, 1/4 in</li> </ul>

Problem	Cause	Correction
<b>HEATING OF SHORTENING SECTION (Continued)</b>		
<p>Heating of shortening too slow</p>	<ul style="list-style-type: none"> <li>• Supply line too small - low gas volume</li> <li>• Improper ventilation system</li> <li>• Improper air flow to burners</li> </ul>	<ul style="list-style-type: none"> <li>• Increase supply line size Refer to Installation Instructions Section of Operator's Manual</li> <li>• Refer to Installation Instructions Section of Operator's Manual</li> <li>• Observe burners</li> <li>• Check gas pressure.</li> <li>• Check blower for restriction of airflow</li> </ul>
<p>Shortening overheating</p>	<ul style="list-style-type: none"> <li>• Programming wrong in the Program Mode</li> <li>• Faulty PC board</li> <li>• Faulty temperature probe</li> </ul>	<ul style="list-style-type: none"> <li>• Check temperature setting</li> <li>• Remove and replace control panel</li> <li>• Remove and replace temperature probe</li> </ul>

Problem	Cause	Correction
<b>SHORTENING FOAMING/DRAINING SECTION</b>		
Foaming or boiling over of shortening	<ul style="list-style-type: none"> <li>• Water in shortening</li> <li>• Improper or bad shortening</li> <li>• Improper filtering</li> <li>• Cold zone full of cracklings</li> <li>• Improper rinsing after cleaning the fryer</li> </ul>	<ul style="list-style-type: none"> <li>• At end of Cook Cycle, drain shortening and clean frypot; add fresh shortening</li> <li>• Use recommended shortening</li> <li>• Refer to the procedure covering filtering the shortening</li> <li>• Filter shortening</li> <li>• Clean and neutralize the frypot; rinse with vinegar to remove the alkaline, then rinse with hot water and dry frypot</li> </ul>
Shortening will not drain from frypot	<ul style="list-style-type: none"> <li>• Drain valve clogged with crumbs</li> <li>• Drain valve will not open by pulling the handle</li> </ul>	<ul style="list-style-type: none"> <li>• Open valve - push cleaning rod through drain opening from inside of frypot</li> <li>• Replace cotter pins in valve coupling</li> </ul>
Shortening leaking	<ul style="list-style-type: none"> <li>• Obstruction in drain</li> <li>• Faulty drain valve</li> </ul>	<ul style="list-style-type: none"> <li>• Remove obstruction through drain valve</li> <li>• Replace drain valve</li> </ul>

**1-4. ERROR CODES**

In the event of a control system failure, the digital display will show an error message which are coded: “E-4”, “E-5”, “E-6”, “E-10”, “E-15”, “E-20A-D”, “E-41”, “E-46”, “E-47”, “E-48”, “E-70B”, and “E-92”. A constant tone is heard when an error code is displayed; and to silence this tone, press any of the product buttons.

<b>DISPLAY</b>	<b>CAUSE</b>	<b>PANEL BOARD CORRECTION</b>
“E-4”	Control board overheating	Turn switch to OFF position, then turn switch back to ON; if display still shows “E-4”, the board is getting too hot; check for signs of overheating behind the control panel; once panel cools down, the controls should return to normal; if “E-4” persists, replace the control
“E-5”	Shortening overheating	Turn switch to OFF position, then back to ON; if display shows “E-5”, the heating circuits and temperature probe should be checked; once the unit cools down, the controls should return to normal; if “E-5” persists, replace the control
“E-6A”	Temperature probe open	Turn switch to OFF position, then turn switch back to ON; if display shows “E-6”, have the temperature probe checked
“E-6B”	Temperature probe shorted	Turn switch to OFF position, then turn switch back to ON; if display shows “E-6”, have the temperature probe checked
“E-10”	High limit	Reset the high limit by manually pushing up on the red reset button; if the high limit does not reset, the high limit must be replaced; call Henny Penny’s Service Department
“E-15”	Drain switch	Close the drain using the drain valve handle; if display still shows “E-15”, call Henny Penny’s Service Department
“E-20A”	Air pressure switch failure (stuck closed)	Press the timer button to try the ignition process again; and if “E-20A” persists, call Henny Penny’s Service Department
“E-20B”	Draft fan or air pressure switch failure (stuck open)	Press the Timer button to try the ignition process again; and if “E-20B” persists, call Henny Penny’s Service Department
“E-20C”	Ignition module failure	Press the Timer button to try the ignition process again; and if “E-20C” persists, call Henny Penny’s Service Department
“E-20D”	Modules working but no ignition	Press the Timer button to try the ignition process again; and if “E-20D” persists, call Henny Penny’s Service Department



**4-2. ERROR CODES (Continued)**

<b>DISPLAY</b>	<b>CAUSE</b>	<b>PANEL BOARD CORRECTION</b>
“E-41”	Programming failure	Turn switch to OFF position, then back to ON; if display shows “E-41”, the control should be re-initialized (see Programming section); if the error code persists, replace the control panel
“E-46”	Eeprom memory write error	Turn switch to OFF position, then back to ON; if display shows “E-46”, the control should be re-initialized (see Programming section); if the error code persists, replace the control panel
“E-47”	A-to-D failure (Analog converter chip)	Turn switch to OFF position, then back to ON; if display shows “E-47”, the control should be re-initialized (see Programming section); if the error code persists, replace the control panel
“E-48”	Input system error (CPU can’t read buttons digital inputs)	Turn switch to OFF position, then back to ON; if display shows “E-48”, the control should be re-initialized (see Programming section); if the error code persists, replace the control panel
“E-70B”	Faulty power switch, or switch wiring; faulty I/O board	Have power switch checked, along with its wiring; have Input/Output board replaced if necessary
“E-92”	24-VAC fuse on I/O board open	Have components, in 24-volt circuit (I.E., hi limit, drain switch) checked for shorts

## SECTION 2. MAINTENANCE

### 2-1. INTRODUCTION

This section provides checkout and replacement procedures, for various parts of the fryer. Before replacing any parts, refer to the Troubleshooting section to aid you in finding the cause of the malfunction.

### 2-2. MAINTENANCE HINTS

1. A multimeter will help you to check the electric components.
2. When the manual refers to the circuit being closed, the multimeter should read zero unless otherwise noted.
3. When the manual refers to the circuit being open, the multimeter should read infinity.



**Do not move the fryer with hot shortening in the frypot or filter pan. Severe burns can result from splashing hot shortening.**

4. Remove weights from the frame to easily access rear of fryer.

### 2-3. PREVENTIVE MAINTENANCE

To ensure a long life of the fryers and their components, regular maintenance should be performed. Refer to the chart below.

Frequency	Action
Twice Daily	Filter Shortening (See Operator's Manual)
Monthly	Check Dilution Box, Clean as needed (See Cleaning the Dilution Box Section)
Annually	Clean Blower Wheel (See Cleaning the Blower Wheel Section)
Annually	Lubricate Lid Rollers in back of fryer. (See Lubricating Lid Rollers Section)

## 2-4. HIGH TEMPERATURE LIMIT CONTROL

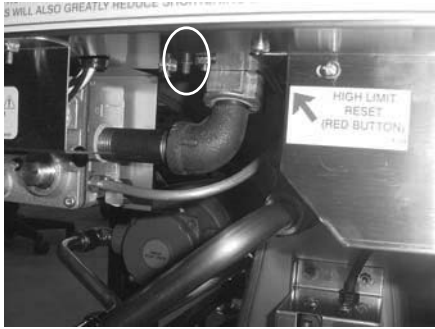

This high temperature control is a safety, manual reset control, which senses the temperature of the shortening. If the shortening temperature exceeds 425°F (218°C), this switch opens and shuts off the heat to the frypot. When the temperature of the shortening drops to a safe operation limit, manually reset by pressing the red reset button. The red reset button is located under the control panel, in the front of the fryer. Once reset, the frypot starts heating.

Before replacing a high temperature limit control, check to see that its circuit is closed.

### Checkout

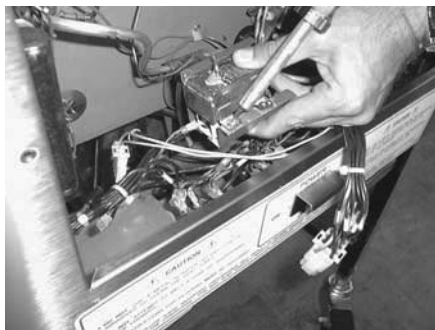
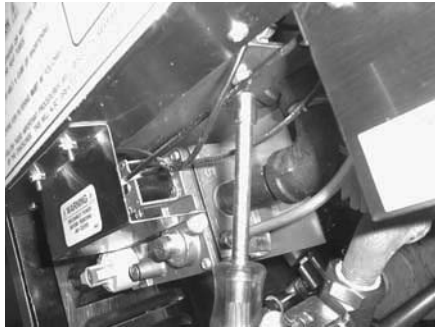

## NOTICE

The shortening temperature must be below 380°F (193°C) to accurately perform this check.

1. Remove electrical power supplied to the fryer.



**To avoid electrical shock or property damage, move the Power switch to OFF and disconnect main circuit breaker, or unplug cord at wall receptacle.**

2. Remove the control panel.
3. Remove the two nuts securing the high limit bracket to the unit, and pull the bracket from the unit.
4. Remove the two screws securing the high limit to the bracket, and remove the high limit from the bracket.
5. Remove the two electrical wires from the high temperature limit control.
6. Manually reset the control, then check for continuity between the two terminals after resetting the control. If the circuit is open, replace the control, then continue with this procedure. (If the circuit is closed, the high limit is not defective. Reconnect the two electrical wires.)

**2-4. HIGH TEMPERATURE  
LIMIT CONTROL  
(Continued)**

**Replacement**



**To avoid electrical shock or property damage, move the POWER switch to OFF and disconnect main circuit breaker, or unplug cord at wall receptacle.**

1. If the tube is broken or cracked, the control will open, shutting off electrical power. The control cannot be reset.
2. Drain shortening from the frypot and discard. A substance in the tube could contaminate the shortening.
3. Remove control panel.
4. Loosen small inside screw nut on capillary tube.
5. Remove capillary bulb from bulb holder inside the frypot.
6. Straighten the capillary tube.
7. Remove larger outside nut that threads into pot wall, and remove defective control from control panel area.
8. Insert new control and replace screws.
9. Uncoil capillary line, starting at capillary tube, and insert through frypot wall.



**To avoid electrical shock or other injury, run the capillary line under and away from all electrical power wires and terminals. The tube must never be in such a position where it could accidentally touch the electrical power terminals.**

10. Carefully bend the capillary tube as shown in photo and place into bulb brackets.

**2-4. HIGH TEMPERATURE  
LIMIT CONTROL  
(Continued)**

11. Pull excess capillary line from pot and tighten nut into frypot wall.

**CAUTION**

*Be sure capillary bulb of high limit is positioned so it doesn't interfere with the carrier or get damaged when cleaning the frypot.*

12. With excess capillary line pulled out, tighten smaller nut.
13. Replace front panel.
14. Refill with shortening.

**2-5. COOK/PUMP SWITCH**

The COOK/PUMP switch is a three way rocker switch with a center OFF position. With the switch in the COOK position the fryer operates. With the switch in the PUMP position the filter pump operates, but the unit will not heat.



**To avoid electrical shock or property damage, move the power switch to OFF and disconnect main circuit breaker, or unplug cord at wall receptacle.**

**Checkout**

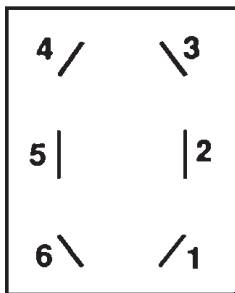

1. Remove control panel.
2. Label and remove wires from the switch.
3. OFF position-should be open circuit anywhere on the switch.
4. COOK position. Check from: #5 to #6 closed circuit  
#1 to #2 closed circuit
5. PUMP position. Check from: #4 to #5 closed circuit  
#3 to #2 closed circuit

**NOTICE**

Check across the jumpers on the wires of the COOK/PUMP switch. These jumpers have resistors and capacitors which may be faulty.

**2-5. COOK/PUMP SWITCH**  
**(Continued)**  
**Replacement**



1. With control panel removed, and wires off of the switch, push in on tabs on the switch to remove from the panel.
2. Replace with new switch, and reconnect wires to switch following the wiring diagram.
3. Replace the control panel.

**2-6. TEMPERATURE PROBE**  
**REPLACEMENT**

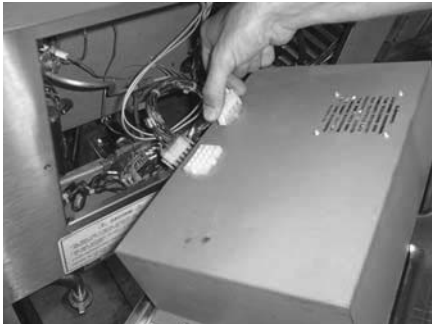

The temperature probe relays the actual shortening temperature to the control. If it becomes disabled, “E06” will show in the display. Also, if the temperature is out of calibration more than 10°F, or 10°C, the temperature probe should be replaced as

1. Remove electrical power supplied to the fryer.



**To avoid electrical shock or property damage, move the power switch to OFF and disconnect main circuit breaker, or unplug cord at wall receptacle.**

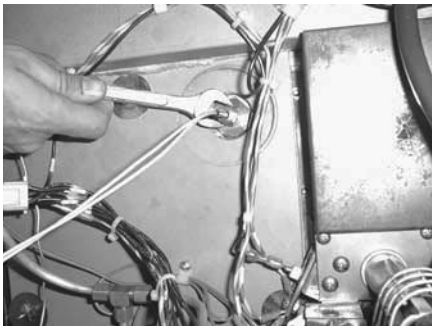

2. Drain the shortening from the frypot.
3. Remove the control panel.
4. Using a 1/2" wrench, remove the nut on the compression fitting.
5. Remove the temperature probe from the frypot.

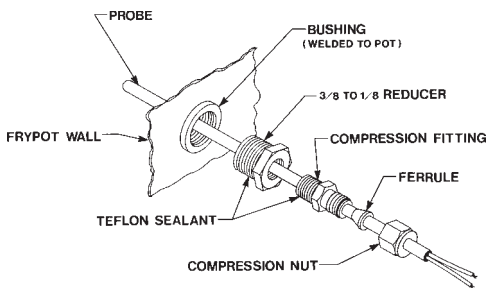

6. Place the nut and new ferrule on the new temperature probe and insert the temperature probe into the compression fitting until it extends one-half (1/2) inch (1.3 cm) into the frypot. Use the temperature probe gauge provided in the temperature probe kit, to ensure proper placement in frypot. See Figures 2-1 and 2-2.

**Figure 2-1**

**2-6. TEMPERATURE PROBE REPLACEMENT (Continued)**

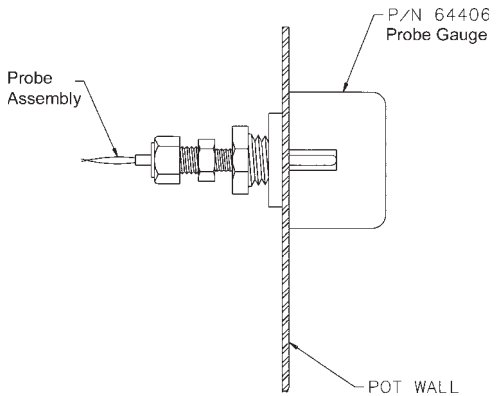

**Figure 2-2**

**2-7. COMPLETE CONTROL PANEL-HENNY PENNY**



7. Tighten hand tight and then a half turn with wrench.

**CAUTION**

*Excess force will damage temperature probe.*

8. Connect new temperature probe to PC board and replace control panel.
9. Replace shortening.
10. Turn power on and check out fryer.

Should the control panel become inoperative, follow these instructions for replacing the board.

1. Remove electrical power supplied to the fryer.



**To avoid electrical shock or property damage, move the power switch to OFF and disconnect main circuit breaker, or unplug cord at wall receptacle.**

2. Remove the two screws securing the control panel and lift panel up and out
3. Unplug the connectors going to the control board.
4. Install a new control panel.

**2-8. LID COUNTERWEIGHT  
CABLES**

The Lid Counterweight in the back of the fryer balances the weight of the lid system to allow easier opening and closing of the lid. The weight has two cables attached to it, and weighs about 100 lbs. (45.4 Kg).

1. Using a Phillips head screwdriver, remove the screws securing the back and top shrouds of the fryer and remove the shrouds.



2. Raise the lid.

3. Remove the screws securing the shroud to the frame and remove the shroud.



4. Remove the nut from the nylon slide and flip loosened end up over the lid.

5. Remove the 4 keps nuts from the bracket at top of the shroud.

6. Place support under lid arm (ex: block of wood), and remove the weights from the frame in the back of the fryer.



7. Remove the Allen head bolts securing the stabilizer bracket and remove the bracket.



**2-8. LID COUNTERWEIGHT  
CABLES (Continued)**



8. Remove the bolts and spacers securing the pulley bracket, and pull bracket back, to allow access to cable bracket.
9. Pull cable and bracket from unit and remove cable from bracket.
10. Remove cable from weight frame.
11. Thread new cable through pulley.
12. Thread nut on cable and place cable through weight frame.
13. Thread second nut onto end of cable, but do not tighten.
14. Thread nut on other end of cable and place through the bracket, then thread a second nut on the end of the cable. Use the hole in bracket, that is towards the front of the cooker, when mounted. Tighten the nut to the bracket. 2 inches of the threaded cable end, should show above the bracket. See photo below.

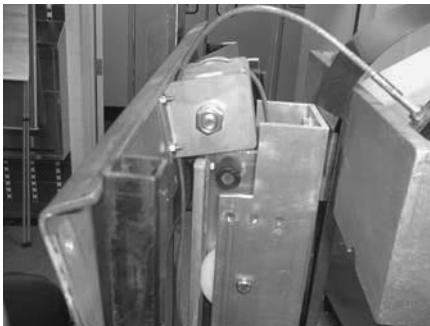

2 inches (50.8 mm)

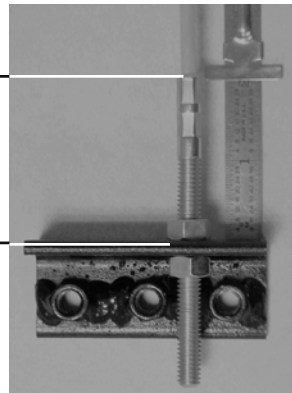

**NOTICE**

Both cables should have the same amount of threads extending through the brackets.

15. Tighten cable onto weight frame.
16. Reassemble in reverse order.

**NOTICE**

Be sure to use pipe sealant on the pipe fittings.



## 2-9. GAS CONTROL VALVE

### Safety Precautions

The gas control valve sends regulated gas to the burners when the controller calls for heat. The control valve can be turned on or off. In the on position, and the power switch on, a spark ignitor lights a standing pilot, and when the control calls for heat, the valve is opened and the burners are ignited.



**TO AVOID INJURY, PROPERTY DAMAGE, OR EXPLOSION, BEFORE REPLACING GAS CONTROL VALVE DO THE FOLLOWING:**

- **MOVE THE POWER SWITCH TO THE OFF POSITION.**
- **DISCONNECT THE MAIN CIRCUIT BREAKER AT THE WALL, OR UNPLUG THE POWER CORD.**
- **TURN OFF THE MAIN GAS SUPPLY TO THE FRYER AND DISCONNECT AND CAP THE SUPPLY LINE TO FRYER, OR POSSIBLE.**

### Replacement



### NOTICE

A voltage check at the gas control valve must be taken four (4) seconds after the power switch is turned to the ON position.

1. Turn gas knob to the OFF position.
2. Remove cover from control valve.
3. Remove the wires from the control valve.



**2-9. GAS CONTROL VALVE**  
**(Continued)**



4. Remove left side panel.

5. Remove control panel.

6. Unscrew nut from inlet line from the control valve.

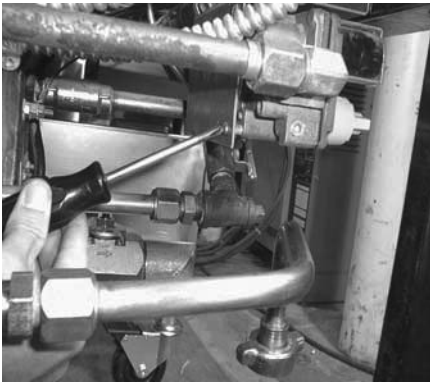

7. Remove the bracket from behind the gas control valve.

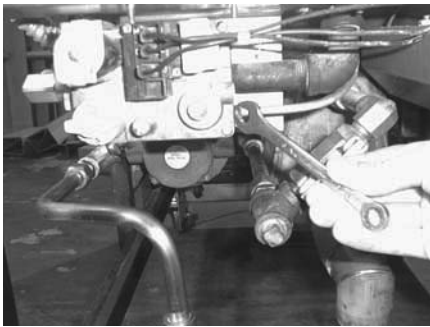

8. Remove pilot light tube from gas control valve.

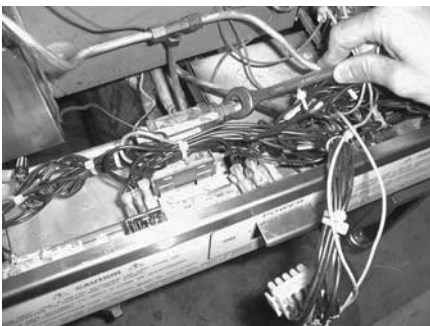

9. Loosen fittings from tee and pull control valve assembly from the unit.

10. Remove the fittings from the defective control valve, and place fittings on new valve.

12. Reassemble in reverse order.

## 2-10. BLOWER ASSEMBLY

The blower motor circulates air into the burner area to create the correct heat for the fryer. If the blower fails, a sensor will shut the gas control valve down.

1. Remove the electrical power supplied to the unit.



**To avoid electrical shock or property damage, move the power switch to OFF and disconnect main circuit breaker, or unplug cord at wall receptacle.**



2. Remove back shroud and right side panel.

3. Remove the tube from the blower.

### **NOTICE**

The blower tube will slide out of the bracket, instead of bolted, on the newer fryers. See photo below.



4. Remove the bracket from the frame.

**2-10. BLOWER ASSEMBLY**  
**(Continued)**

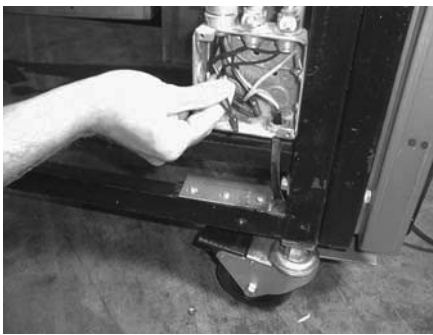
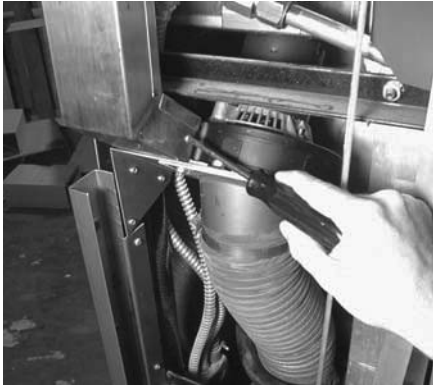

5. Remove the flue.
6. Disconnect wires at junction box.
7. Remove the blower from the plate.
8. Replace new blower in reverse order of procedures.

**2-11. TRANSFORMER**

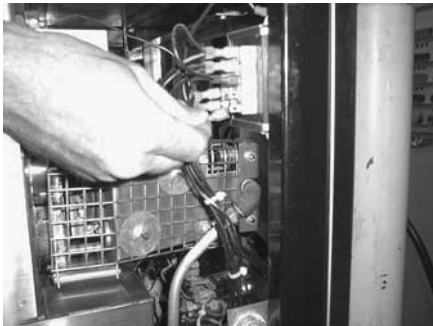

The transformer reduces the voltage down to accommodate those components with low voltage.

1. Remove electrical power supplied to the unit.



**To avoid electrical shock or property damage, move the power switch to OFF and disconnect main circuit breaker, or unplug cord at wall receptacle.**

2. Remove the control panel.
3. Remove the two (2) screws securing the transformer to the unit and remove transformer.
4. Remove the wires from transformer.



Mark wires before removal to insure new transformer is wired correctly.

5. Replace with new transformer in reverse order.

## 2-12. AIRFLOW SWITCH

### Replacement

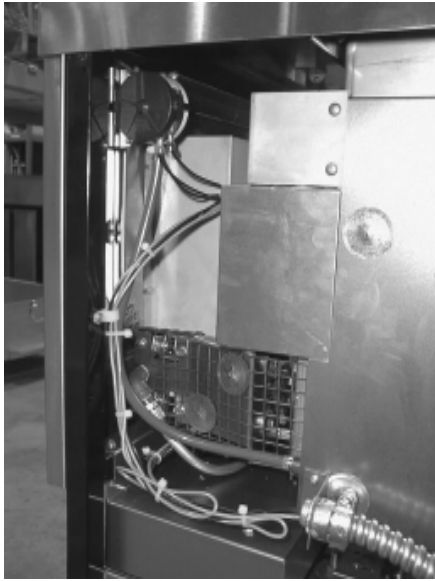

The airflow switch senses the flow of air coming from the blower. If the airflow is reduced below a set amount, the switch will cut power to the control valve, which shuts the burners down.

1. Remove electrical power supplied to the unit.



**To avoid electrical shock or property damage, move the power switch to OFF and disconnect main circuit breaker, or unplug cord at wall receptacle.**

2. Remove control panel.
3. Remove screws securing air switch to the frame, and remove switch.
3. Pull hose from switch from under fryer.
4. Disconnect wires from switch.

### **NOTICE**

Mark wires before removal to insure new airflow switch is wired correctly.

5. Install new airflow switch in reverse order.

### **CAUTION**

*To avoid property damage, do not tamper with, or disassemble this component. It is set and sealed from the factory and is not to be adjusted.*

## 2-13. DRAIN MICROSWITCH

Upon pulling out on the drain handle, the microswitch should be activated and the unit will not heat, but when the handle is pushed back, the unit should operate properly. The bracket on the microswitch is slotted so it can be adjusted backward or forward.

1. Remove electrical power supplied to the unit.



**To avoid electrical shock or property damage, move the power switch to OFF and disconnect main circuit breaker, or unplug cord at wall receptacle.**

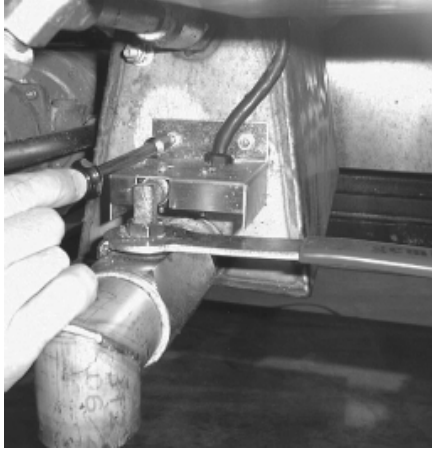

2. The following check should be made to determine if the drain switch is defective.

- a. Remove bracket from the unit.

- b. Remove wires from the switch.

- c. Check for continuity across the two outside terminals on the drain switch. If circuit is open, the drain switch is bad. The circuit should only be opened by pressing on the actuator of the drain switch.

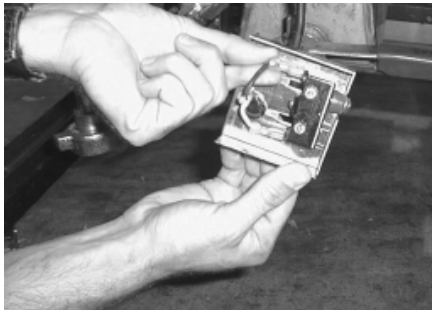

3. To replace switch, remove switch from the bracket, and install switch in reverse order.

4. Test to see if drain valve handle actuates the switch. The gap between the drain switch and the shaft should be no more than 1/8" (3 mm).

NOTE: Listen for click of switch while pulling drain valve handle.



## **2-14. DRAIN VALVE AND EXTENSION**

### **Replacement**



The drain valve opens when the drain valve handle is pulled out and drains the shortening out of the pot.

1. Using a 3/8" socket, remove the nuts securing the drain switch bracket, and pull the bracket from the studs.
2. Remove the nut securing the drain handle and pull the handle from the drain valve.
3. Using a large adjustable wrench, unscrew the drain valve and extension from the unit.
4. Replace the drain valve and extension.
5. Replace the drain switch bracket.
6. Adjust the microswitch to be no more than 1/8" (3 mm) from the shaft of the drain valve.

**NOTE:** Listen for click of switch while pulling drain valve handle.



## 2-15. AIR VALVE

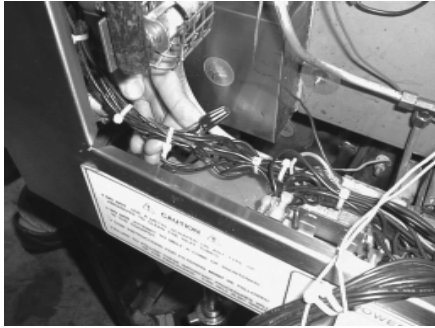

The air valve allows circulation of the shortening in the frypot to keep the shortening at a uniform temperature.

1. Remove electrical power supplied to the unit.



**To avoid electrical shock or property damage, move the power switch to OFF and disconnect main circuit breaker, or unplug cord at wall receptacle.**

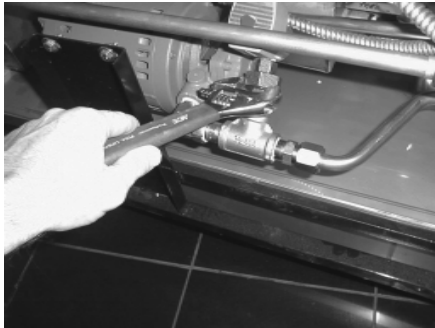

2. Remove the left side panel.



3. Remove the wires from the wire nuts.

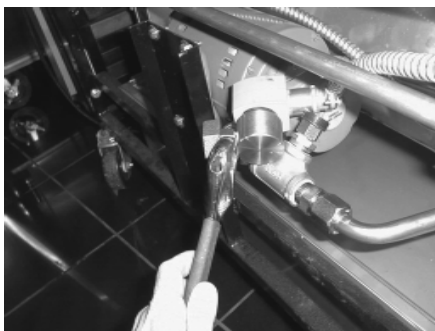

4. Disconnect union at the valve.

5. Loosen the nut on the conduit connector and pull coil from conduit.

6. Remove close nipple and female part of union from valve body.

7. Replace with new valve in reverse order.

**2-16. CLEANING THE DILUTION BOX**

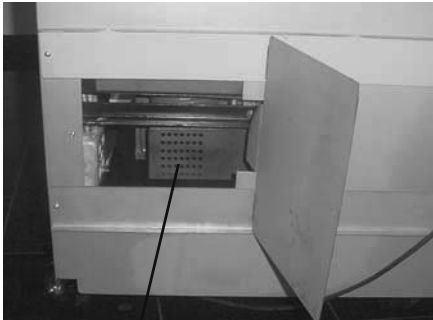

Dilution Box

Clean the dilution box monthly to ensure the unit operates efficiently and without failures.

1. Make sure unit is off, and close and lock the lid.



**Lid should be in locked down position. Failure to do so could result in personal injury.**

2. Unscrew the wingnut on the lower left back access panel of the fryer and remove the access panel. Clean the dilution box with a cloth or brush. Make sure the holes in the box are free of debris. Replace the back access panel when finished.



Depending on the breading location and conditions within the kitchen area, the dilution box may need cleaned more often.

**2-17. CLEANING THE BLOWER WHEEL**



The blower wheel must be cleaned annually to ensure the unit operates efficiently and without failures.

1. Make sure unit is off, and raise the lid.



**Lid should be in locked down position. Failure to do so could result in personal injury.**

2. Remove the back shroud of the unit.
3. Remove the hose from the blower housing.



The blower tube will slide out of the bracket, instead of bolted, on the newer fryers. See photo at left.

Depending on the breading location and conditions within the kitchen area, cleaning the blower wheel, may need to be done more frequently.

4. Clean the fins of the blower wheel, using a brush, or straight blade screwdriver. Make sure the fins are clean of any debris.

## 2-18. IGNITION MODULES

### LED Indication

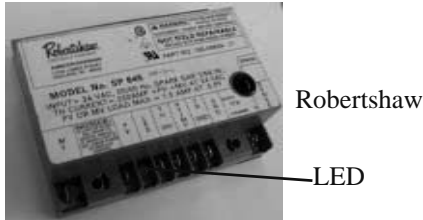
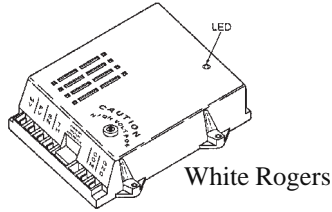

### Replacement



The ignition modules send 24 volts to the ignitors and gas valve.

Two different modules are in the field. The White Rogers modules have a red LED, and the Robertshaw modules have a green LED. These LEDs help to identify a failure.

For the White Rogers' module, when the control calls for heat, the LED will flash, then go out, indicating the control is functional. If the LED continues to flash, the module did not sense a pilot flame. If the LED stays on continuously, an internal fault has been detected, and the module should be replaced.

For the Robertshaw, when the control calls for heat, the LED will be on continuously, indicating the control is functional. If the LED flashes, the module did not sense a pilot flame. If the LED goes out while the control is calling for heat, an internal fault had been detected, and the module should be replaced.

1. Remove electrical power supplied to the unit.



**To avoid electrical shock or property damage, move the power switch to OFF and disconnect main circuit breaker, or unplug cord at wall receptacle.**

2. Remove the control panel as discussed in Complete Control Panel Section.
3. Remove the condensation drain pan.
4. Using a Phillips head screwdriver, remove the screws securing the module cover and remove the cover.
5. Label and remove the wires from the module.
6. Using a 3/8" socket and Phillips head screwdriver, remove the nuts and screws securing the module and remove it from the unit.
7. Replace with module in reverse order.

## 2-19. IGNITOR ASSEMBLY

### Replacement

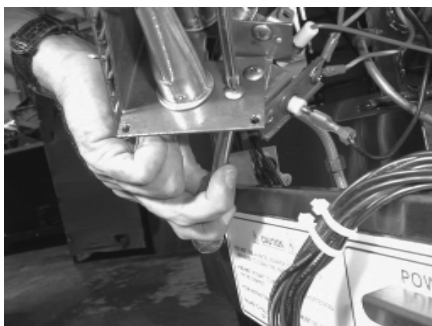
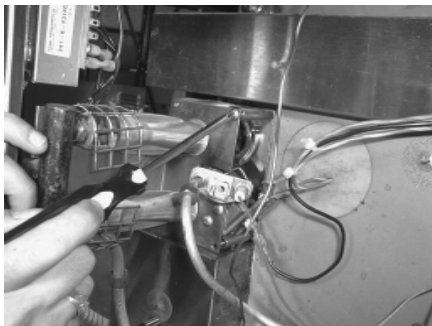
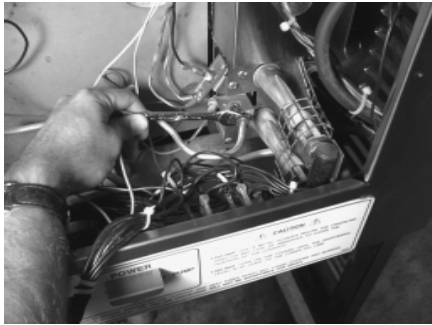

The 391 has electronic spark ignition, that lights a standing pilot.

1. Remove electrical power supplied to the unit.



To avoid electrical shock or property damage, move the power switch to OFF and disconnect main circuit breaker, or unplug cord at wall receptacle.



**TO AVOID INJURY, PROPERTY DAMAGE, OR EXPLOSION, BEFORE REPLACING GAS CONTROL VALVE DO THE FOLLOWING:**

- MOVE THE POWER SWITCH TO THE OFF POSITION.
  - DISCONNECT THE MAIN CIRCUIT BREAKER AT THE WALL, OR UNPLUG THE POWER CORD.
  - TURN OFF THE MAIN GAS SUPPLY TO THE FRYER AND DISCONNECT AND CAP THE SUPPLY LINE TO FRYER, OR POSSIBLE.
2. Remove the control panel as discussed in Complete Control Panel Section.
  3. Disconnect the 1/4" gas line fitting from the pilot assembly.
  4. Follow the wire from the spark ignitor to the module, and remove the wire from the module.
  5. Remove the left, or right side panel, depending upon which ignitor assembly to be removed.
  6. Disconnect gas line (for the left ignitor assembly).
  7. Remove the 4 screws securing the burner assembly, and pull the assembly from the unit.
  8. Using a Phillips head screwdriver, remove the screw securing the ignitor assembly to the burner assembly, and pull the ignitor assembly from the unit.
  9. Secure the new assembly with the screw previously removed, making sure the assembly is turned to provide a 1/8" gap between the spark ignitor and the hood of the pilot assembly.

**2-20. FLAME SENSOR ASSEMBLY**

**Replacement**



The flame sensor should glow a bright red when the pilot is lit and allows the gas valve to open. If it does not sense a flame, it shuts down the gas valve.

1. Remove electrical power supplied to the unit.



**To avoid electrical shock or property damage, move the power switch to OFF and disconnect main circuit breaker, or unplug cord at wall receptacle.**

2. Remove the control panel as discussed in the Complete Control Panel Section..
3. Pull the wire off of the terminal of the flame sensor.
4. Using Phillips head screwdriver, remove the screw securing the flame sensor assembly, and remove the assembly from the unit.
5. Replace with new assembly in reverse order. Make sure the flame sensor has 1/4” gap between it and the pilot hood.

**2-21. IGNITOR AND FLAME SENSOR ADJUSTMENT**

For the proper function of the ignitor and flame sensor it is critical that they are at the adjusted properly. The flame rectification, from the flame sensor to the module, should at least be 1.3 microamps. See photos.

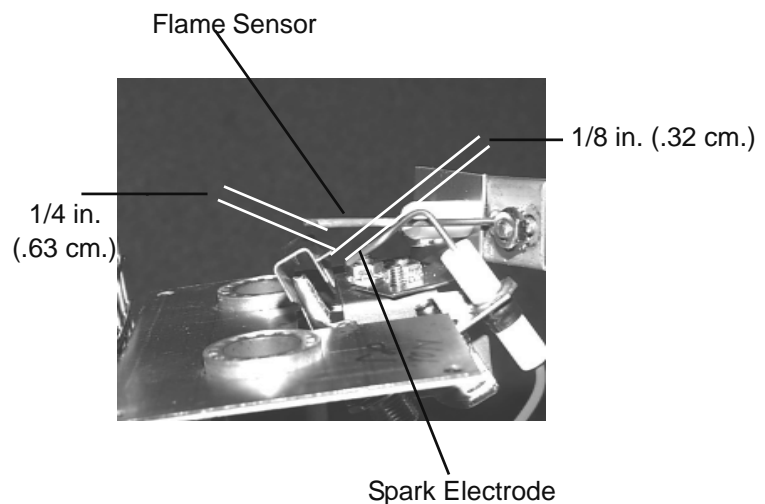
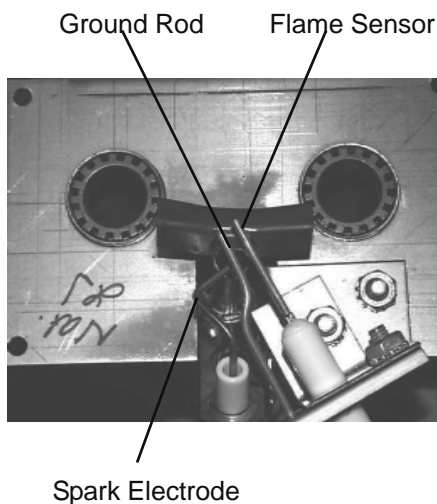

**NOTICE**

If the burner assembly is removed from the cooker to install and adjust the parts, once the assembly is re-installed, check the spacing of the components again.

## **2-22. NYLATRON STRIPS REPLACEMENT**



1. Remove back and top shrouds
2. Remove the screw and keps nut securing the nylatron to the extension.
3. Remove the screws securing the guides, and slide the guides up and out from the top of the shroud.
4. Pull the broken piece from the unit. The nylatron is separated into two pieces, top and bottom.
5. Reassemble in reverse order.

**2-23. LUBRICATING LID  
ROLLERS**

The lid rollers, in the back of the cooker, should be lubricated at least once a year, to allow the lid easy movement.

1. Remove the back shroud of the cooker.



2. Using spindle lube, part number 12124, place a small amount of lube on both top and bottom rollers. Make sure to lube both left and right rollers.

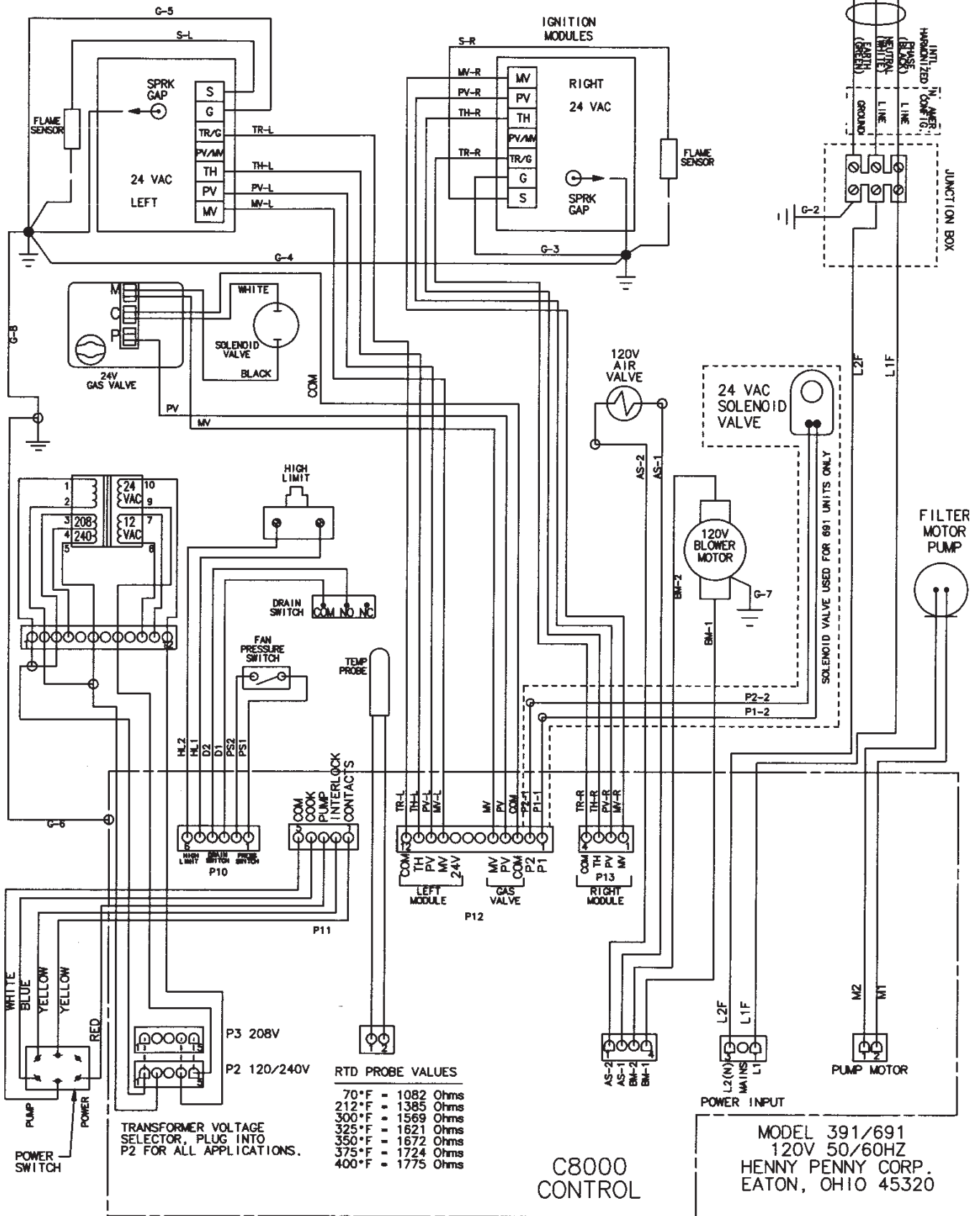

**RTD PROBE VALUES**

70°F	=	1082 Ohms
212°F	=	1385 Ohms
300°F	=	1569 Ohms
325°F	=	1621 Ohms
350°F	=	1672 Ohms
375°F	=	1724 Ohms
400°F	=	1775 Ohms

TRANSFORMER VOLTAGE SELECTOR, PLUG INTO P2 FOR ALL APPLICATIONS.

**C8000 CONTROL**

**MODEL 391/691**  
120V 50/60HZ  
HENNY PENNY CORP.  
EATON, OHIO 45320

65830



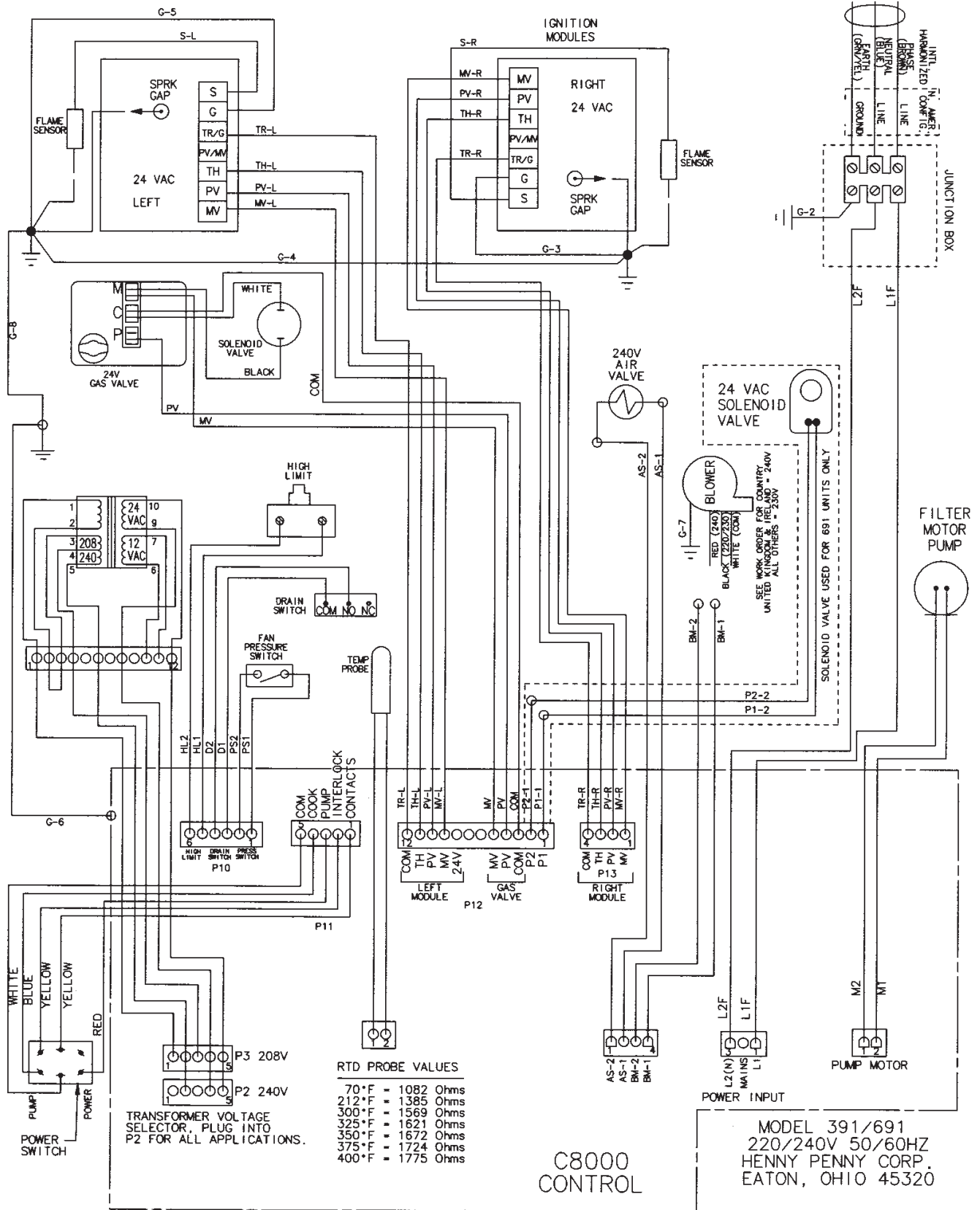

65832

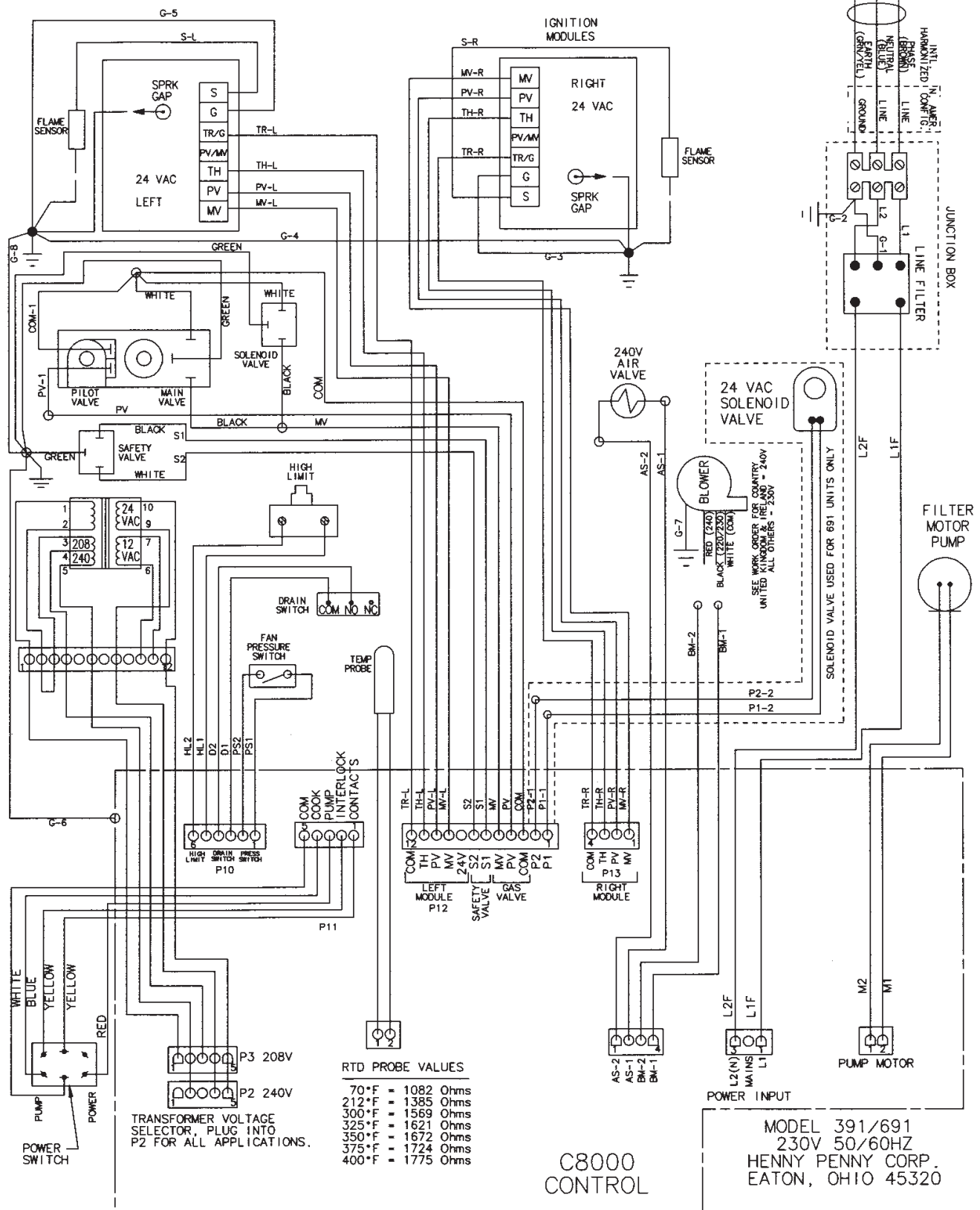

65825



## SECTION 3. PARTS INFORMATION

### **3-1. INTRODUCTION**

This section lists the replaceable parts of the Henny Penny Model OFG-391.

### **3-2. GENUINE PARTS**

Use only genuine Henny Penny parts in your fryer. Using a part of lesser quality or substitute design may result in damage to the unit or personal injury.

### **3-3. WHEN ORDERING PARTS**

Once the parts that you want to order have been found in the parts list, write down the following information:

Item Number	<u>2</u>	Example:
Part Number	<u>16738</u>	
Description	<u>High Limit</u>	

From the data plate, list the following information:

Product Number	<u>01100</u>	Example:
Serial Number	<u>0001</u>	
Voltage	<u>120</u>	

### **3-4. PRICES**

Your distributor has a price parts list and will be glad to inform you of the cost of your parts order.

### **3-5. DELIVERY**

Commonly replaced items are stocked by your distributor and will be sent out when your order is received. Other parts will be ordered, by your distributor, from Henny Penny Corporation. Normally, these will be sent to your distributor within three working days.

### **3-6. WARRANTY**

All replacement parts (except lamps and fuses) are warranted for 90 days against manufacturing defects and workmanship. If damage occurs during shipping, notify the carrier at once so that a claim may be properly filed. Refer to warranty in the front of this manual for other rights and limitations.

### **3-7. RECOMMENDED SPARE PARTS FOR DISTRIBUTORS**

Recommended replacement parts, stocked by your distributor, are indicated with √ in the parts lists. Please use care when ordering recommended parts, because all voltages and variations are marked. Distributors should order parts based upon common voltages and equipment sold in their territory.

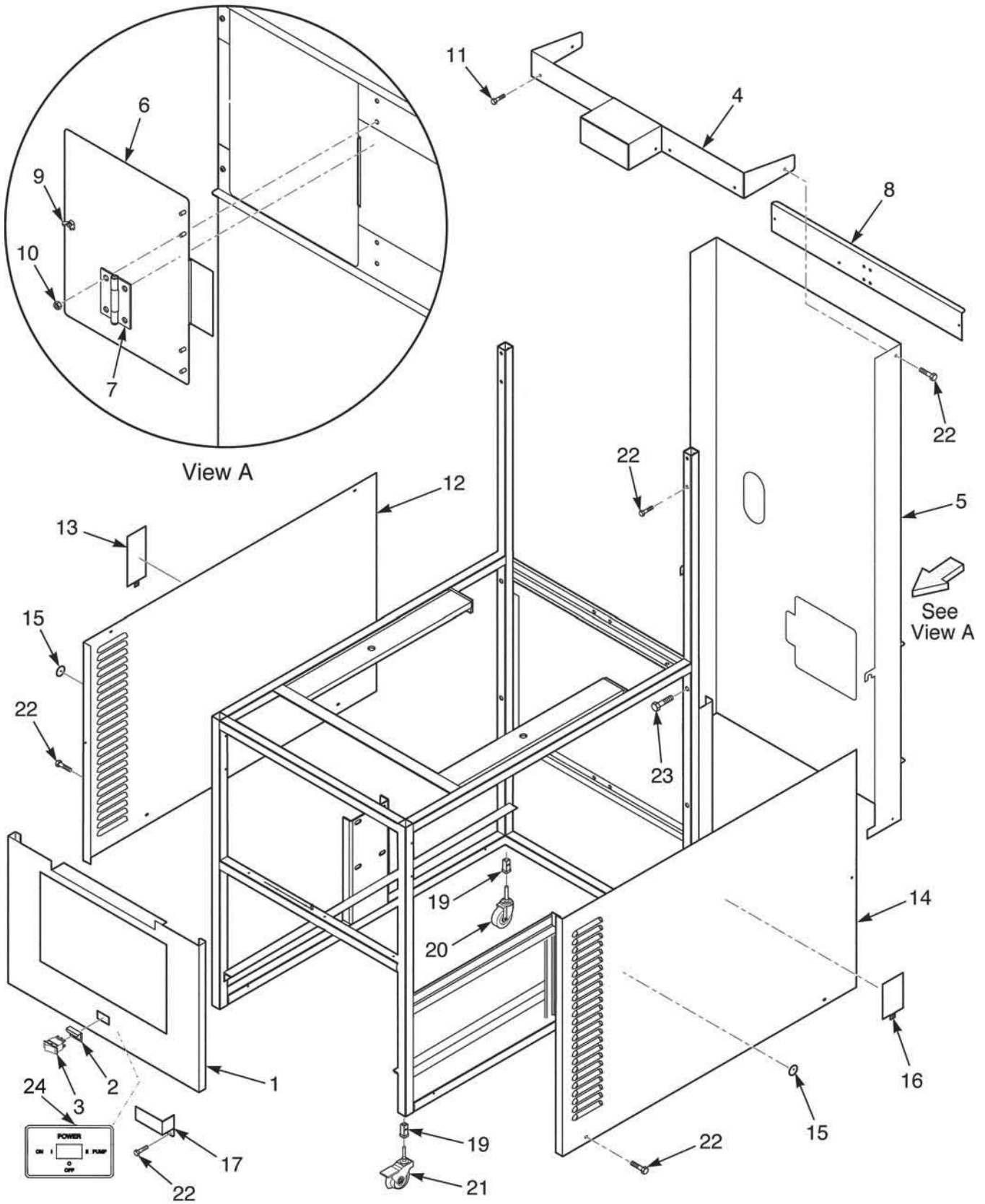

Figure 3-1. Frame and Cover Assembly

Figure & Item No.	Part No.	Description	Qty.
3-1		FRAME & COVER ASSEMBLY	
1	39796	WELDMENT – CONTROL PANEL FRONT .....	1
2	53669	GUARD – POWER SWITCH .....	1
√ 3	29898	SWITCH – POWER .....	1
4	55608	TOP COVER – REAR SHROUD .....	1
5	58261	REAR SHROUD – ACCESS ASSEMBLY .....	1
6	58258	. ACCESS COVER – STUD ASSEMBLY .....	1
7	58256	. HINGE – 2" LEAF HT .....	2
8	62056	. BRACE – REAR SHROUD .....	2
9	NS03-033	. NUT, WING – SS 10-24 .....	1
10	NS03-002	. NUT, ACORN #10-24 .....	8
11	SC03-005	. SCREW SD #8 X 1/2 PH PHD .....	4
12	66940	PANEL – SIDE LH .....	1
13	36337	DOOR – ACCESS .....	1
14	66941	PANEL – SIDE RH .....	1
15	52204	COVER – PILOT VIEW .....	2
16	35179	COVER – ACCESS COVER .....	1
17	51741	COVER, GAS VALVE WIRE .....	1
19	54225	1" INSERT – LEG MACHINED .....	4
20	53673	CASTER, SWIVEL 4" .....	2
21	37246	CASTER W/BRAKE & SWIVEL LOCK .....	2
22	SC03-005	SCREW .....	8
23	SC01-215	SCREW .....	4
24	54921	LABEL - POWER/PUMP .....	1

√ recommended parts

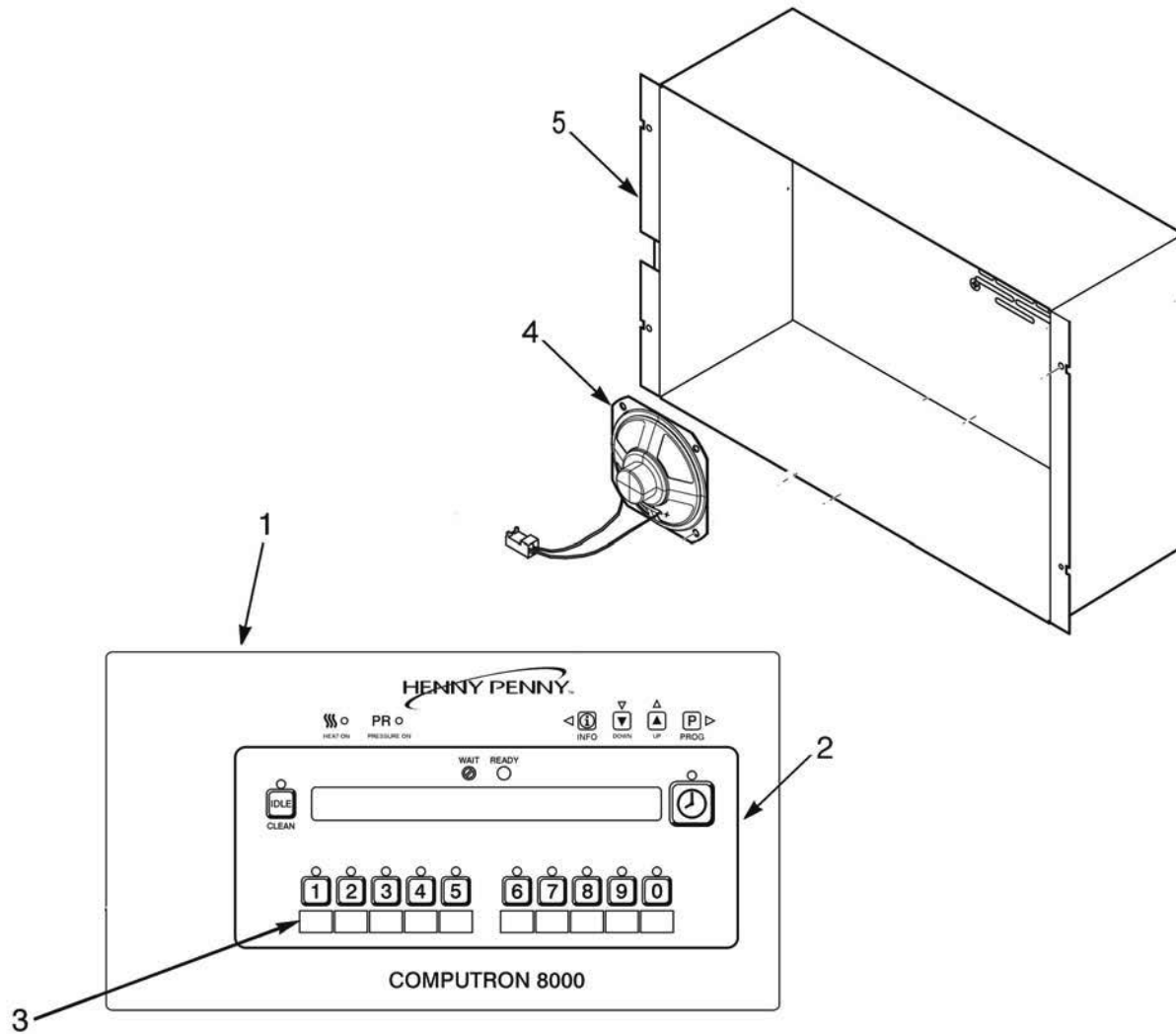

Figure & Item No.	Part No.	Description	Qty.
3-2		CONTROL PANEL ASSEMBLY	
√ 1	65279RB	ASSY - 8 HEAD C8000 CONTROL .....	1
2	65236	DECAL - 8 HEAD C8000 .....	1
3	32634	MENU CARD C8000 BLANK .....	1
3	65922	MENU CARD C8000 8-HD HP GM .....	1
√ 4	26974	WIRE/SPEAKER ASSY .....	1
5	65661	STUD ASSY-8-HEAD-C8000- COVER .....	1
6*	65893RB	ASSY - I/O BOARD .....	1

√ recommended parts

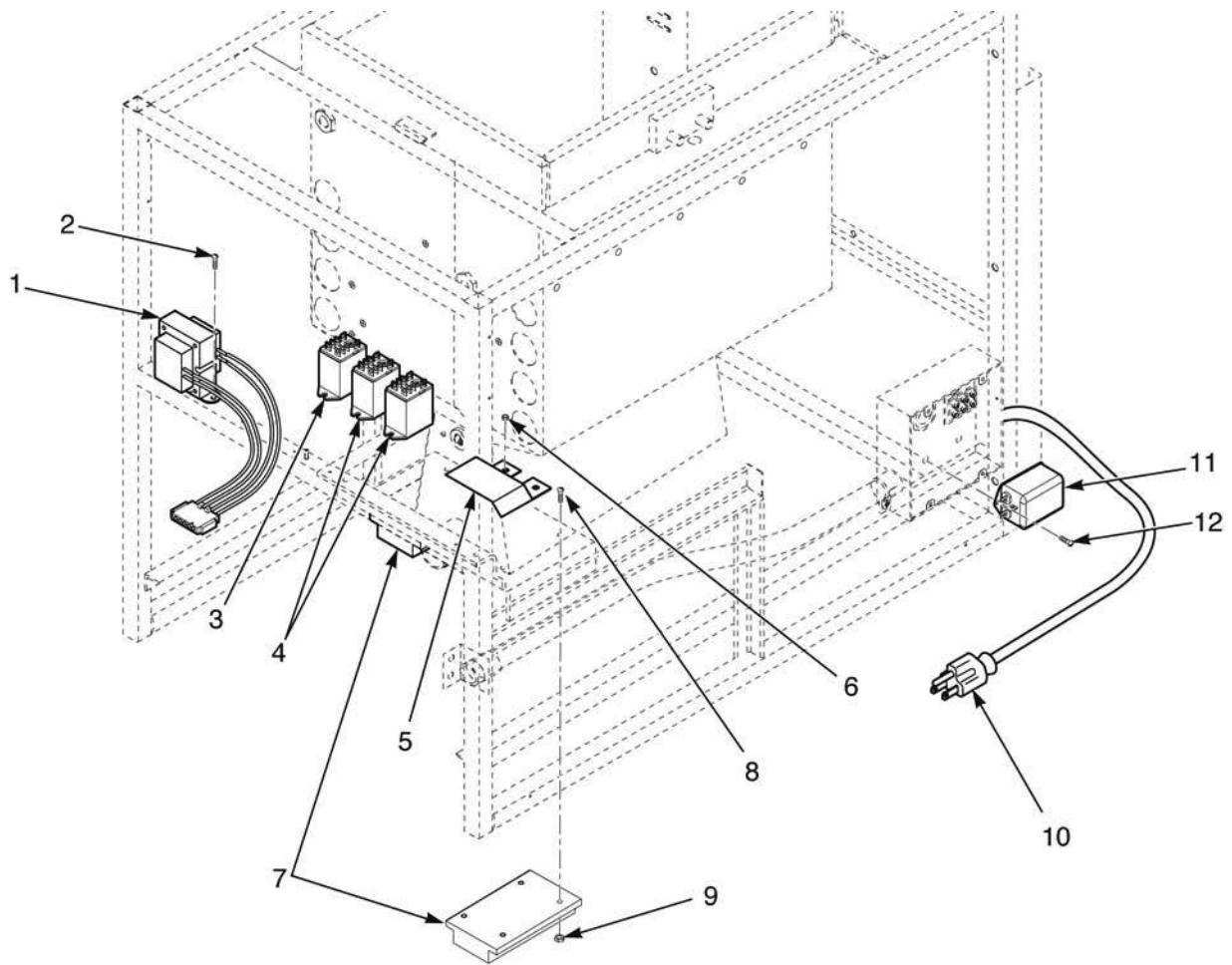

Figure & Item No.	Part No.	Description	Qty.
3-3		ELECTRICAL CONTROLS	
√ 1	29571	TRANSFORMER ASSY - 10/24V .....	1
2	SC03-005	SCREW .....	2
√ 3	140012	KIT - RELAY - 120V - SN: BT0903002 & Below .....	1
√ 3	81914	RELAY - 120V - SN: BT0903003 & Above .....	1
√ 3	56394	Power Relay-240V .....	1
√ 4	60818	Relay - 24V-10A .....	2
5	62053	SHIELD - WIRE - RH BURNER NON CE .....	1
6	NS02-005	NUT .....	2
√ 7	21347	IGNITION MODULE .....	2
√ 7	54924	IGNITION MODULE - CE .....	2
8	SC01-214	SCREW #10-32 X 1 PH THD SS .....	4
9	NS02-001	NUT HEX KEPS #10-32 C .....	4
10	53656	POWER CORD - 120V .....	1
√ 11	54988	FILTER - 220V - 50/60HZ 6ACE .....	1
12	SC01-006	SCREW #10-32 X 3/8 PH THD C .....	2

√ recommended parts



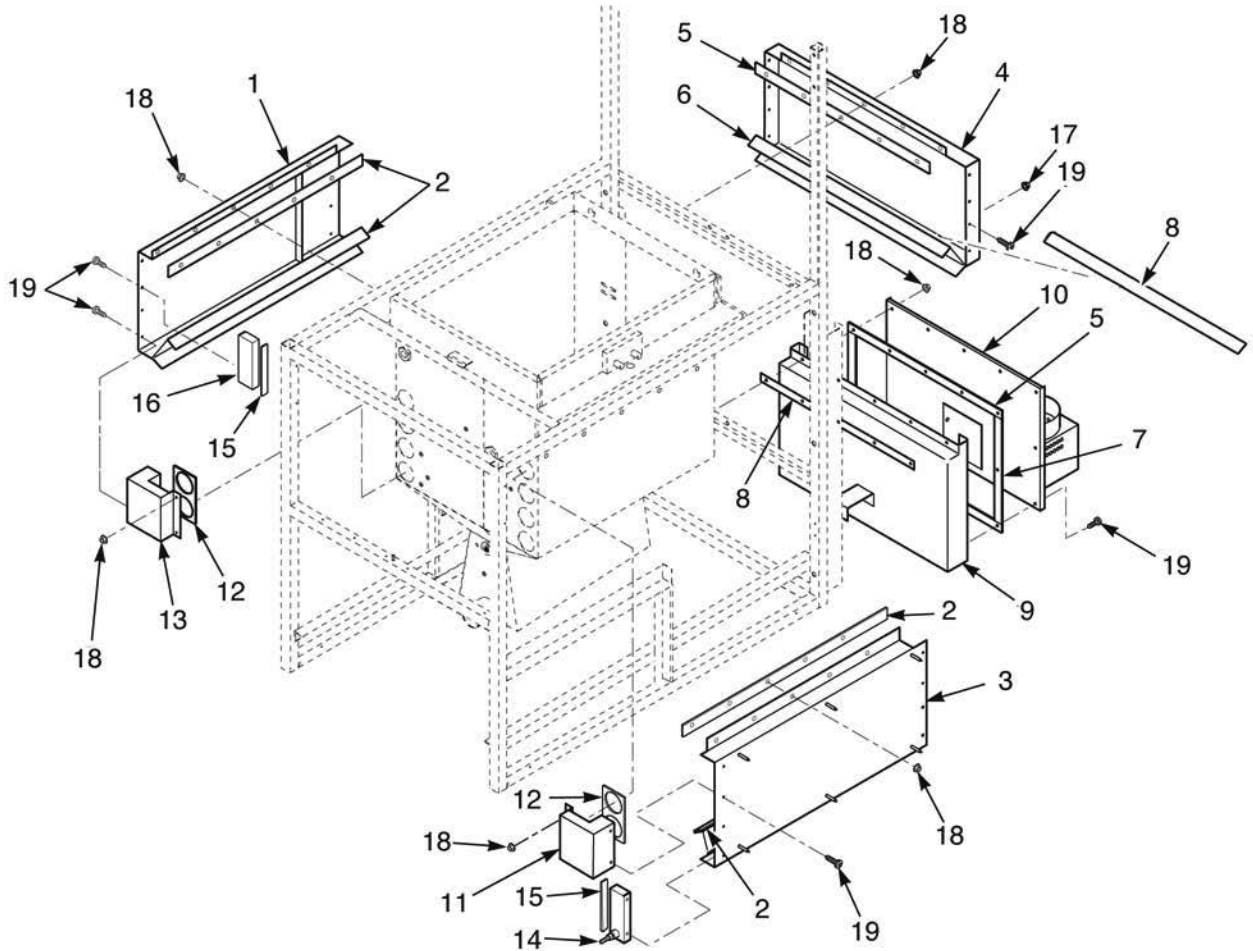

Figure & Item No.	Part No.	Description	Qty.
3-4		FRYPOT COVERS AND INSULATION	
1	52799	ASSY-INSUL/LFT. C/CHAMBER .....	1
2	52041	INSULATION-C/CHAMBER MOUNTIN .....	4
3	52798	ASSY-INSUL/RT. C/CHAMBER .....	1
4	52800	ASSY-INSUL/REAR C/CHAMBER .....	1
5	52038	INSULATION-LOWER CHAMBER DUC .....	3
6	52040	INSULATION-REAR C/CHAMBER .....	1
7	51897	INSULATION-LOWER CHAMBER COV .....	2
8	52039	INSULATION-C/CHAMBER COLLAR .....	1
9	52120	ASSY-LOWER C/CHAMBER DUCT .....	1
10	52801	ASSY-INSUL/CHAMBER COVER .....	1
11	52795	ASSY INSUL/TUBE-CHAMBER RT. ....	1
12	52792	INSULATION-TUBE TO C/CHAMBER .....	2
13	52794	ASSY-INSUL/TUBE-CHAMBER LFT. ....	1
14	52797	ASSY-INSUL/LOWER CHAMBER CAP .....	1
15	52793	INSULATION - C/CHAMBER CAP .....	2
16	52796	ASSY-INSUL/UPPER CHAMBER CAP .....	1
17	NS02-005	NUT HEX KEPS #6-32C .....	5
18	NS02-006	NUT HEX KEPS #10-24C .....	34
19	SC02-014	SCREW #8 AB X 3/8 PH #400SS .....	27

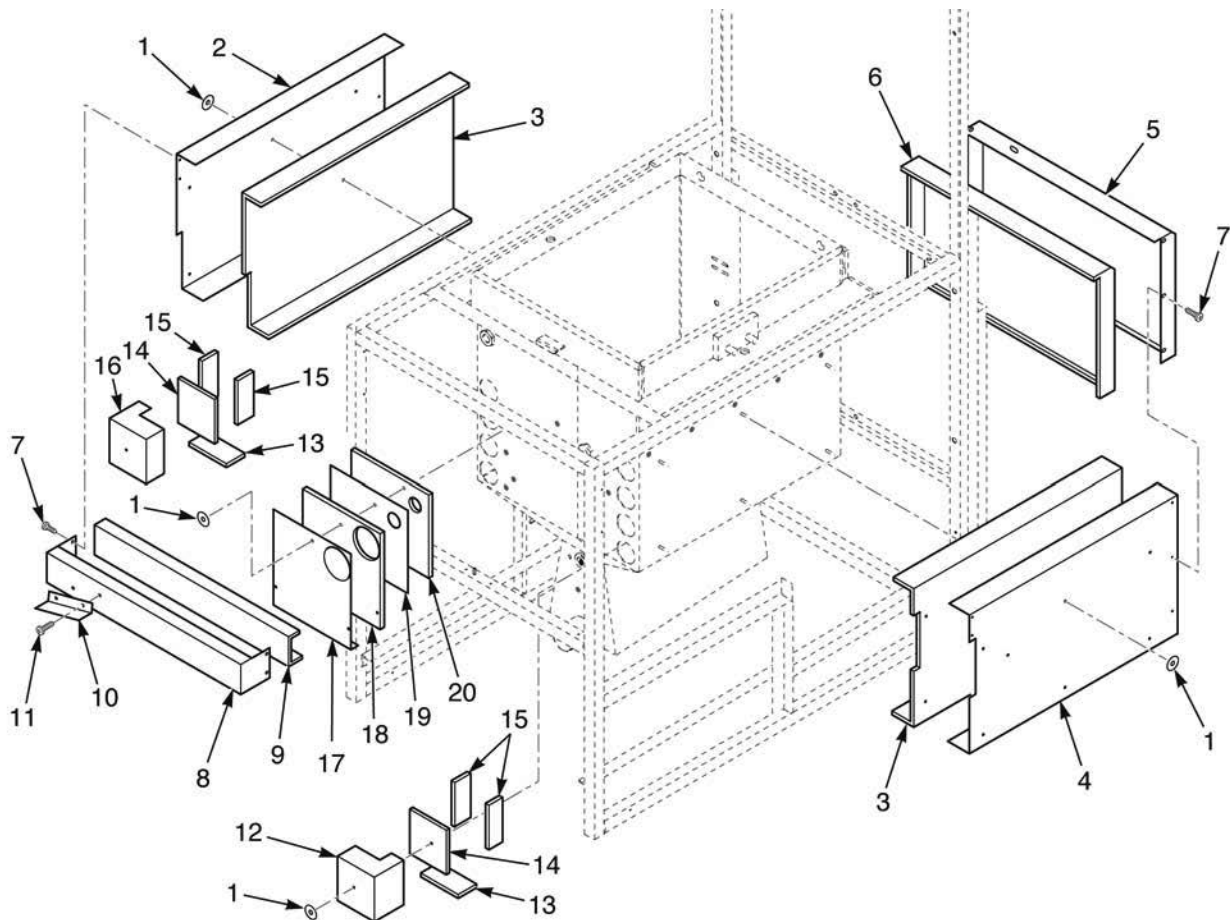

Figure & Item No.	Part No.	Description	Qty.
3-5		INSULATION COVERS	
1	WA02-001	WASHER – INSULATION 1-1/2” DIA. ....	17
2	51763	INSULATION COVER – LEFT .....	1
3	51892	INSULATION – C/CHAMBER SIDE .....	2
4	51765	INSULATION COVER – RIGHT .....	1
5	51759	INSULATION COVER – REAR .....	1
6	51893	INSULATION – REAR C/CHAMBER .....	1
7	SC02-014	SCREW #8-AB X 3/8 PH #400SS .....	10
8	51739	TOP FRONT INSULATION PANEL .....	1
9	51894	INSULATION – TOP FRONT PANEL .....	1
10	62060	SHIELD – HIGH LIMIT .....	1
11	SC03-005	SCREW SD #8 X 1/2 PH PHD .....	2
12	51753	INSULATION COVER – TUBE TRAN RH .....	1
13	53661	INSUL. – TUBE/CHAMBER-SIDE .....	4
14	53662	INSUL – TUBE/CHAMBER-BOTTOM .....	2
15	53660	INSUL. – TUBE/CHAMBER-BACK .....	2
16	51755	INSULATION COVER – TUBE TRANS .....	1
17	51821	CONTROL INSULATION COVER LH .....	1
18	53659	INSULATION – POT FRONT (FOIL) .....	1
19	51806	POT FRONT INSULATION COVER .....	1
20	53658	INSULATION – POT FRONT .....	1

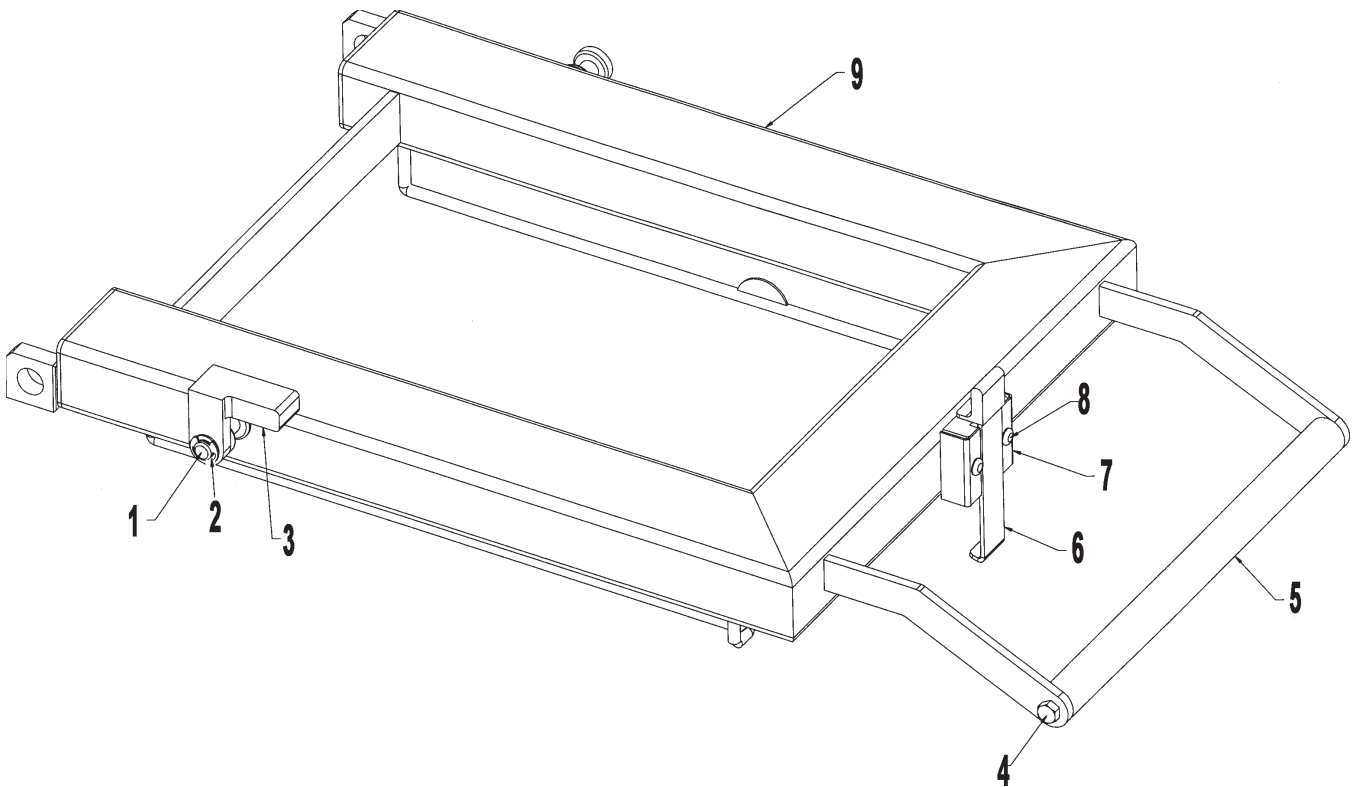

Figure & Item No.	Part No.	Description	Qty.
3-6	65191	Lid Assembly Complete	
1	RR01-004	Ring - Retaining - 1/2 in.	1
2	WA01-020	Washer - .513 ID-.750 OD-.05 THK	1
3	51531	Stop - Lid, Cast	1
4	SC01-041	Screw - 5/16"-18 x 1 HEX HD C	2
5	55754	Handle Weld Assembly	1
6	55756	Assy. - Latch/Sleeve Coat	1
7	59169	Lid Latch Bracket	1
7a	52498	Spring - Lid Latch	1
7b	51707	Lid Latch Bracket	1
8	SC01-248	Screw 10-32 x 1.25 PH THD SS	2
9	65190	Weldment 390 Lid	1

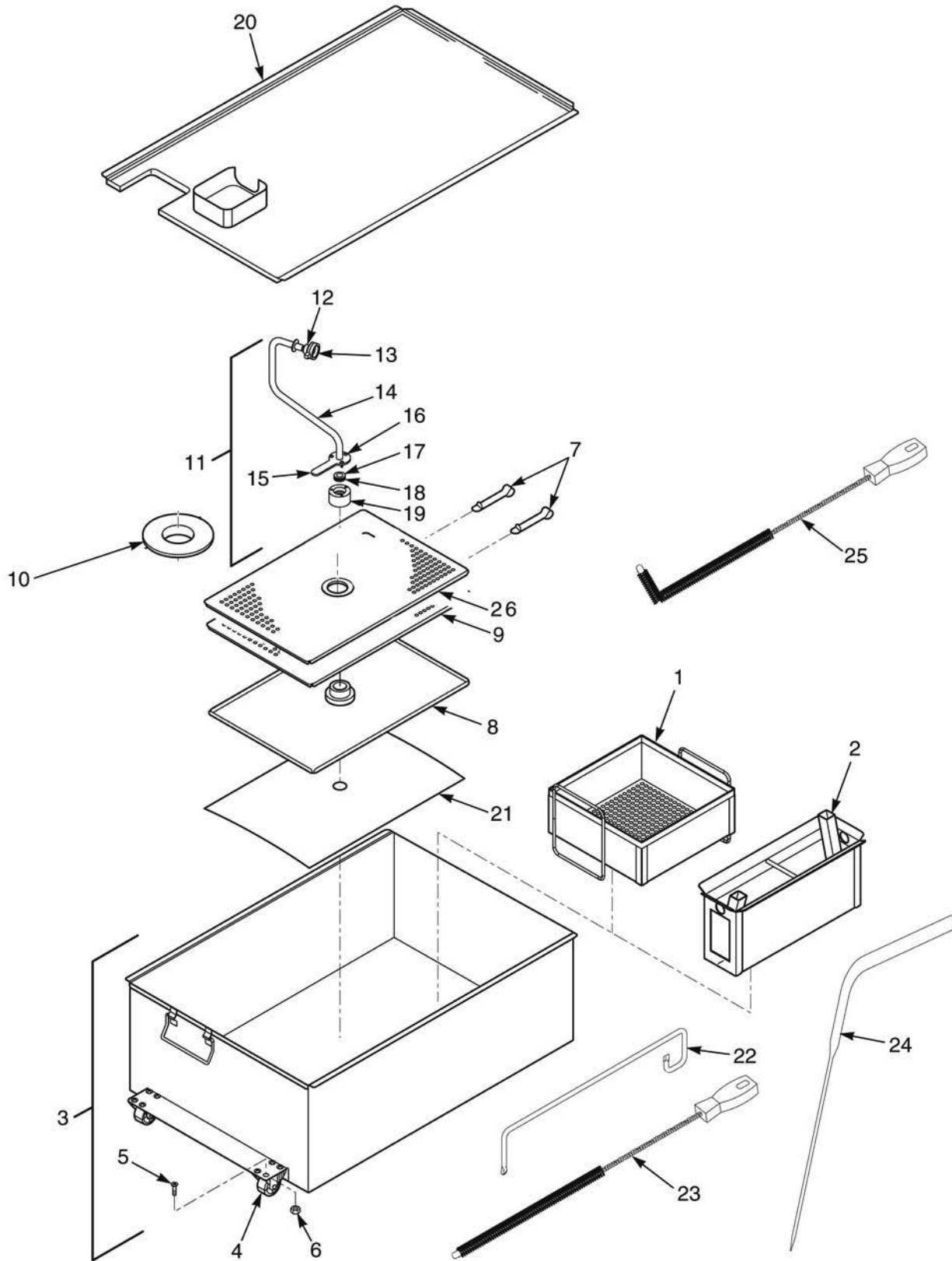

Figure 3-7. Drain Pan and Filter Assembly

Figure & Item No.	Part No.	Description	Qty.
3-7		DRAIN PAN AND FILTER ASSEMBLY	
1	52194	CRUMB CATCHER (OPTIONAL) .....	1
2	03204	CRUMB CATCHER BASKET W/HANDLE (OPTIONAL) ....	1
2	21010	. CRUMB CATCHER BASKET ASSEMBLY .....	1
2	24429	. HANDLE - CRUMB BASKET .....	1
3	52496	FILTER DRAIN PAN ASSEMBLY .....	1
4	52487	. CASTER .....	2
5	SC01-009	. SCREW 1/4-20 X 1/2 .....	8
6	NS02-002	. NUT 1/4-20 .....	8
7	17505	FILTER CLIPS .....	2
8	17503(use 14671)	BOTTOM FILTER SCREEN (SN: KH031JJ AND BELOW) ....	1
8	17503(use 14674)	BOTTOM FILTER SCREEN (SN: KH032JJ TO BT0504001) ...	1
8	65447	BOTTOM FILTER SCREEN (SN: BT0504001 AND ABOVE) ..	1
9	17502(use 14671)	TOP FILTER SCREEN (SN: KH031JJ AND BELOW) .....	1
9	17502(use 14674)	TOP FILTER SCREEN (SN: KH032JJ AND ABOVE) .....	1
10	36305	WASHER & STANDPIPE .....	1
11	55876	STANDPIPE ASSEMBLY (S/N KH031JJ & BELOW) .....	1
11	62081	STANDPIPE ASSEMBLY (S/N KH032JJ to AH085JB) .....	1
11	24212	STANDPIPE ASSEMBLY (S/N AH086JB to BT0504001) .....	1
11	14658	STANDPIPE ASSEMBLY (S/N BT0504001 & ABOVE) .....	1
√ 12	USE 69289	. UNION - MALE FITTING .....	1
√ 13	USE 69289	. UNION - HANDLE FITTING .....	1
14	24211	. WELDMENT, FILTER TUBE AND WASHER .....	1
15	23740	. HANDLE, STANDPIPE 8 HEAD .....	1
16	SC01-245	. SCREW 10-32 X 1/2 .....	3
17	23804	. INSERT, FILTER NUT .....	1
18	OR01-007	. O-RING, FILTER NUT INSERT .....	1
19	55877	. FILTER NUT (S/N KH031JJ & LOWER) .....	1
19	65208	. FILTER NUT (S/N KH032JJ to AH085JB) .....	1
19	23803	. FILTER NUT (S/N AH086JB to BT0504001) .....	1
19	66535	. FILTER NUT - SS (SN: BT0504001 AND ABOVE) .....	1
20	62082	FILTER DRAIN PAN COVER ASSEMBLY .....	1
√ 21	12102	FILTER ENVELOPE PAPER (100 PER CARTON) .....	1
22	52209	ROD - CLEAN OUT .....	1
√ 23	52208	BRUSH .....	1
24	35310	STIRRER .....	1
√ 25	12126	BLACK L-BRUSH .....	1
26	65211	CRUMB CATCHER - SS .....	1

√ recommended parts

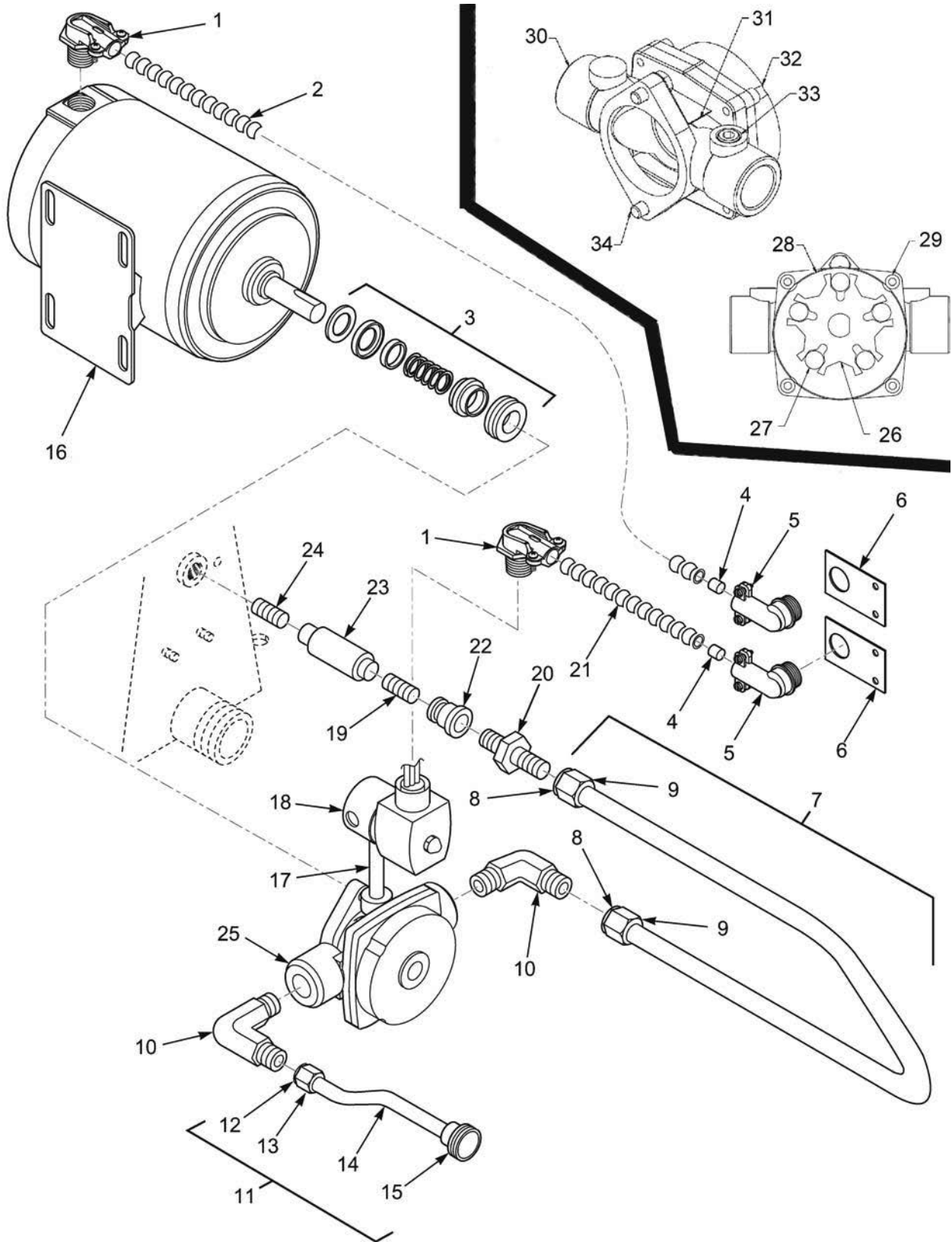

Figure 3-8A. Filter Pump Assembly (SN: LH015JC and below)

Figure & Item No.	Part No.	Description	Qty.
3-8A		FILTER PUMP ASSEMBLY (SN: LH015JC and below)	
1	18107	CONDUIT CONNECTOR 3/8 X 90 .....	2
2	54484	BLOWER/PUMP – FLEXIBLE CONDUIT .....	1
√ 3	17476	PUMP SEAL KIT .....	1
4	18105	ANTI SHORT 3/8 INCH .....	2
5	18644	CONDUIT CONNECTOR 3/8 X 90 .....	2
6	51831	PUMP CONDUIT BRACKET .....	2
7	55757	ASSY – OIL RETURN LINE .....	1
8	16808	SLEEVE, FITTING .....	2
9	16809	NUT, FITTING .....	2
10	17407	CONNECTOR, 1/2 MALE ELBOW .....	2
11	24225	TUBE ASSY – DISCON. TO PUMP .....	1
12	66676	ASSY - TUBING, DISCONNECT TO PUMP .....	1
13	16809	NUT, FITTING .....	1
14	16808	SLEEVE, FITTING .....	1
√ 15	17430(use 69289)	UNION, MALE FITTING .....	1
√ 16	67583	MOTOR – 1/2 HP FILTER PUMP .....	1
17	62050	NIPPLE 1/4 NPT X 2.0 .....	1
√ 18	52125	AIR-SOLENOID VALVE 120V .....	1
√ 18	54908	AIR-SOLENOID VALVE 240V .....	1
19	FP02-024	NIPPLE 3/8 CLOSE .....	1
20	16807	FITTING, CONNECTOR, MALE .....	1
21	54486	AIR VALVE – FLEXIBLE CONDUIT .....	1
22	FP01-122	REDUCER 3/8 TO 1/2 .....	1
23	35472	CHECK VALVE – PRESSURE .....	1
24	FP02-007	NIPPLE 3/8 X 1-1/2 .....	1
25	17437	PUMP SUBASSY 5 GPM .....	1
√ 26	17447	ROTOR - PUMP .....	1
√ 27	17446	ROLLER - TEFLON SET .....	1
√ 28	17453	PUMP O RING GASKET .....	1
√ 29	SC01-132	1/4-20 X 5/8 SOC HD CAP SCREW .....	4
√ 30	17454	BODY - PUMP .....	1
√ 31	17456	PUMP SHIELD .....	2
√ 32	17451	COVER - PUMP .....	1
√ 33	SC01-016	PLUG 1/4 HEX COUNTERSUNK .....	1
√ 34	SC01-026	SCREW 5/16-18 X 3/4 HEX HDC .....	2
35*	85777	1/2” PUMP AND MOTOR .....	1

√ recommended parts

\* not shown

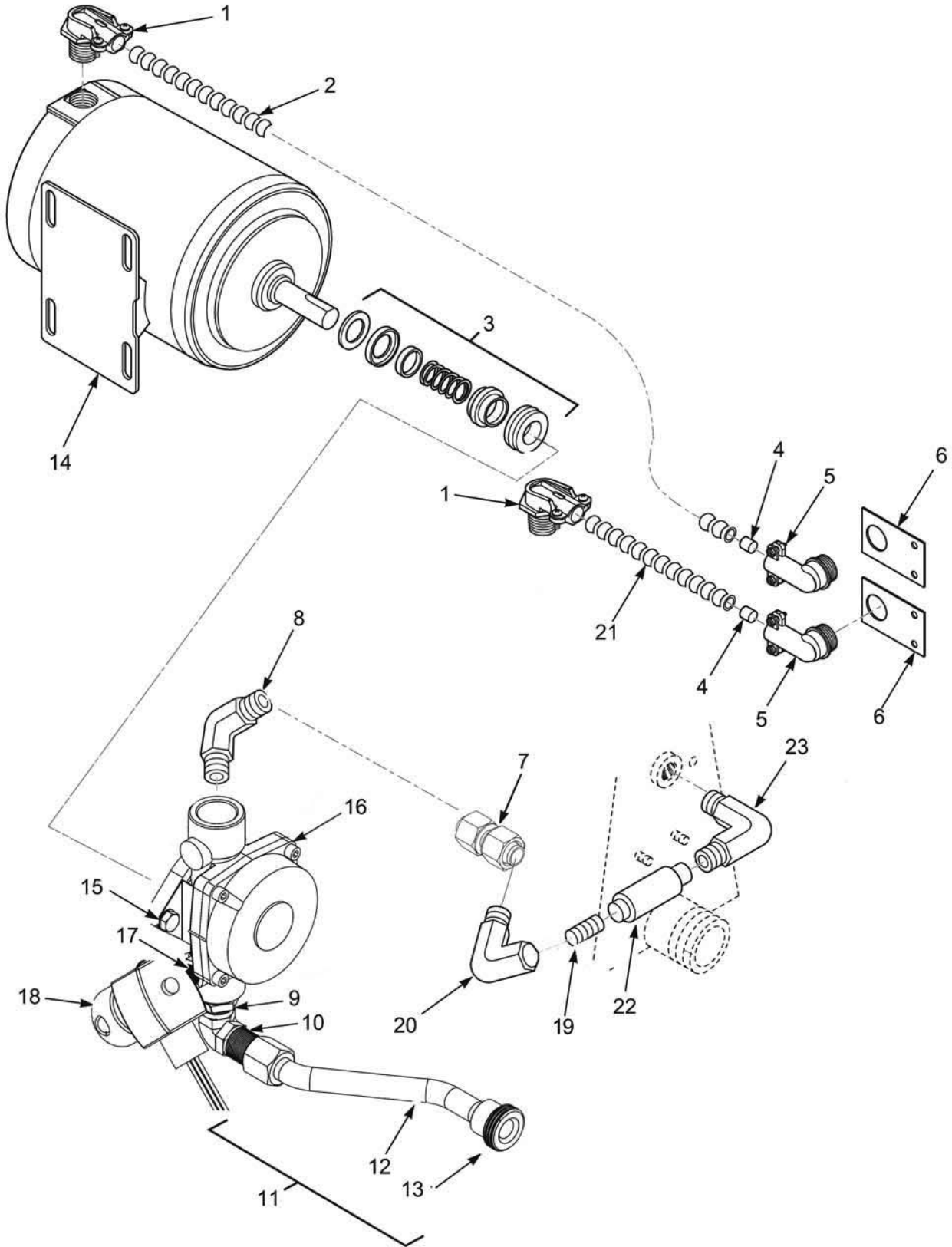

Figure 3-8B. Filter Pump Assembly (SN: LH016JC and above)



Figure & Item No.	Part No.	Description	Qty.
3-8B		FILTER PUMP ASSEMBLY (SN: LH016JC & above)	
1	18107	CONDUIT CONNECTOR 3/8 X 90 .....	2
2	54484	BLOWER/PUMP – FLEXIBLE CONDUIT .....	1
√ 3	17476	PUMP SEAL KIT .....	1
4	18105	ANTI SHORT 3/8 INCH .....	2
5	18644	CONDUIT CONNECTOR 3/8 X 90 .....	2
6	51831	PUMP CONDUIT BRACKET .....	2
7	65080	ASSY – PUMP TO CHECK VLV TUBE-390/690 .....	1
8	FP01-169	CON - 90 MALE 3/4 TUBE 3/4 NPT .....	1
9	FP01-089	BUSHING - REDUCING - 3/4M TO 1/2 .....	1
10	17407	CONNECTOR, 1/2 MALE ELBOW .....	1
11	66574	ASSY – DISCON. TO PUMP .....	1
12	65079	. ASSY – DISCON. TO PUMP TUBE .....	1
√ 13	17430(use 69289)	. UNION, MALE FITTING .....	1
√ 14	67583	MOTOR – 1/2 HP FILTER PUMP .....	1
15	LW02-014	LOCKWASHER - 5/16 INT STAR .....	1
16	64218	ASSY - FILTER PUMP 8 GPM .....	1
17	62050	NIPPLE 1/4 NPT X 2.0 .....	1
√ 18	52125	AIR-SOLENOID VALVE 120V .....	1
√ 18	54908	AIR-SOLENOID VALVE 240V .....	1
19	FP02-037	NIPPLE 3/4 X 2.5 LG BI .....	1
20	FP01-168	CON - 90 FEMALE 3/4 TUBE 3/4 NF .....	1
21	54486	AIR VALVE – FLEXIBLE CONDUIT .....	1
22	21800	VALVE - 3/4 CHECK .....	1
23	FP01-173	ELBOW - 3/4 NPT X 90 MALE NICKEL .....	1
24*	69355	ASSY, 3/4" PUMP AND MOTOR .....	1

√ recommended parts

\* not shown

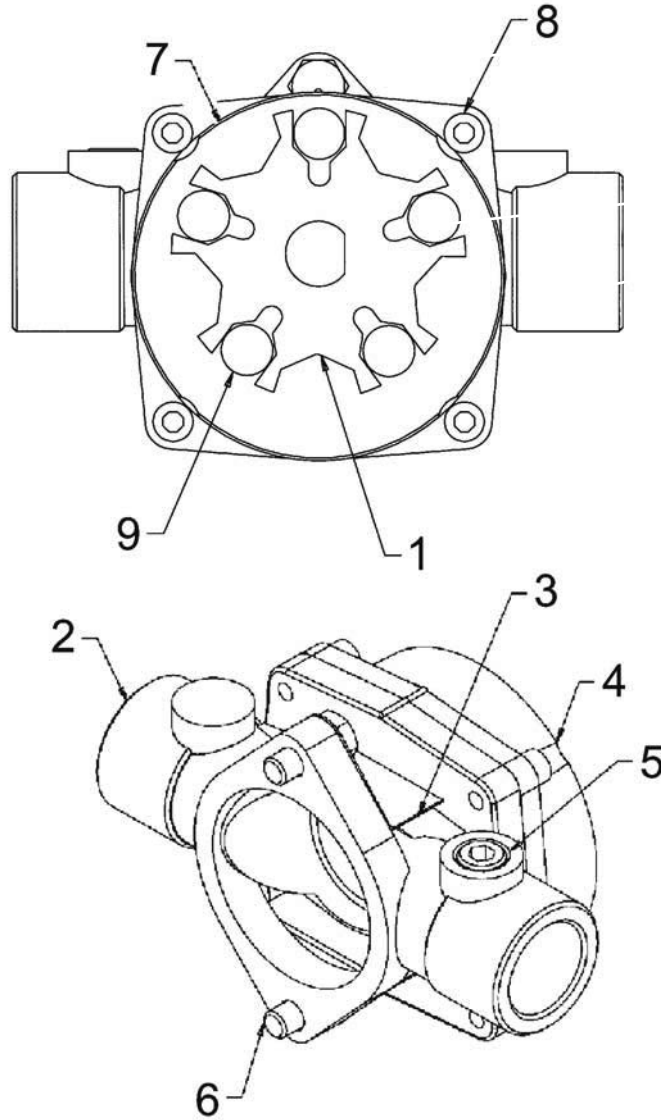

Figure & Item No.	Part No.	Description	Qty.
3-9	64218	FILTER PUMP ASSEMBLY PUMP SUBASSY 8GPM	
√ 1	23468	ROTOR - 8 GPM PUMP .....	1
√ 2	23647	BODY - 8 GPM PUMP .....	1
√ 3	17456	PUMP SHIELD .....	2
√ 4	23470	CAP - 8 GPM PUMP .....	1
√ 5	FP01-020	PLUG 1/4-18 HEX LEVEL SEAL .....	1
√ 6	SC01-026	SCREW 5/16-18 X 3/4 HEX HD C .....	2
√ 7	17453	PUMP O RING GASKET .....	1
√ 8	SC01-132	1/4-20 X 5/8 SOC HD CAP SCREW .....	4
√ 9	23469	ROLLER - 8 GPM PUMP .....	5

√ recommended parts

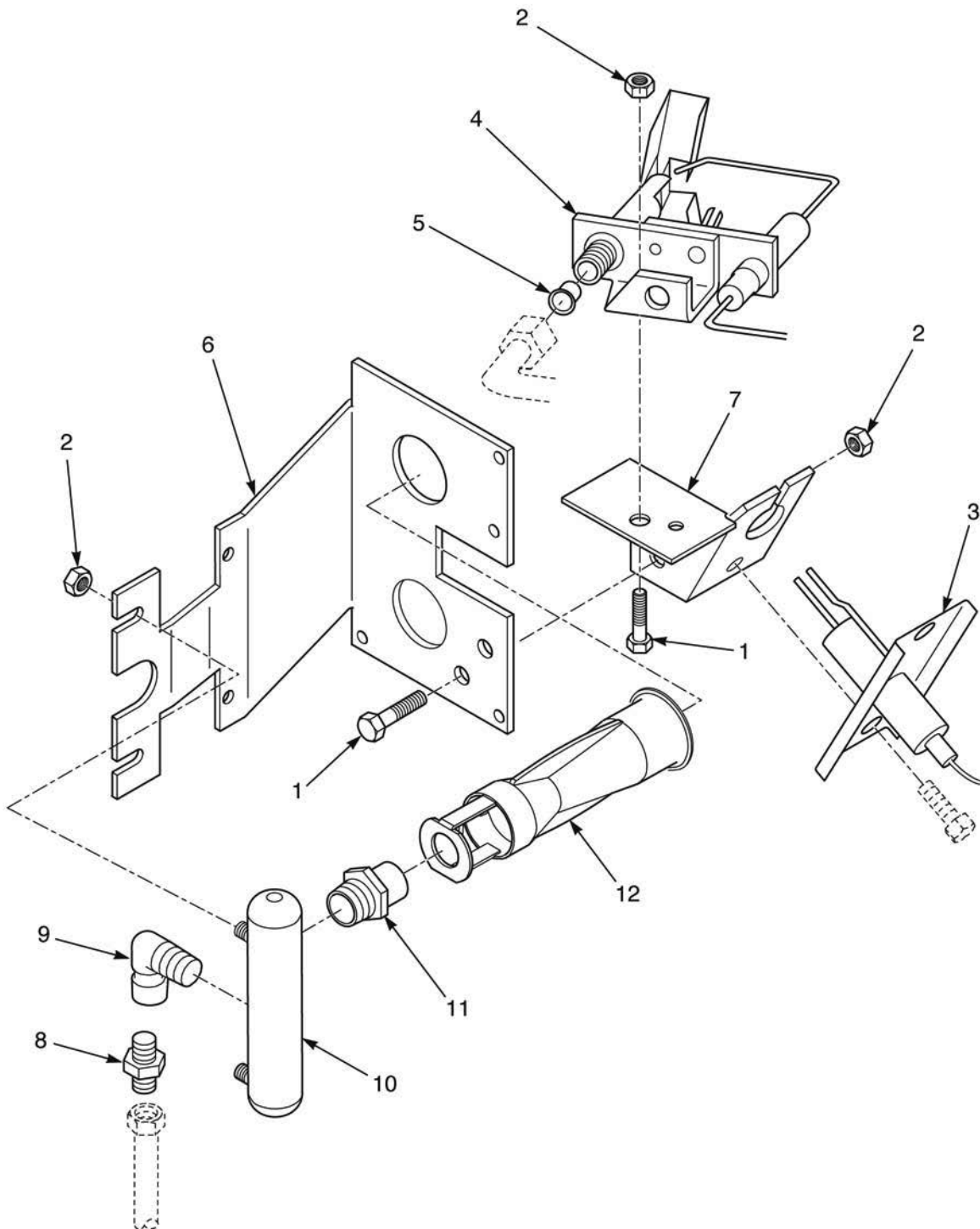

Figure 3-10. Gas Burner Assembly

Figure & Item No.	Part No.	Description	Qty.
3-10		GAS BURNER ASSEMBLY	
0*	56990-01	BURNER ASSY – NATURAL .....	2
0*	56990-02	BURNER ASSY – LP .....	2
0*	56990-03	BURNER ASSY – NATURAL CE .....	2
0*	56990-04	BURNER ASSY – LP CE .....	2
0*	56990-05	BURNER ASSY – PROPANE/BUTANE MIX .....	2
0*	56990-07	BURNER ASSY – NATURAL JAPAN .....	2
0*	56990-06	BURNER ASSY – LP/BUTANE MIX 70% PRO 30% BU .....	2
1	SC01-084	. SCREW #10-32 X 3/8 HEX HD S .....	8
2	NS02-001	. NUT HEX KEPS #10-32 C .....	8
√ 3	52074	. FLAME SENSOR .....	2
√ 4	52075	. PILOT & IGNITOR ASSY – NATURAL .....	2
√ 4	21333	. PILOT & IGNITOR ASSY – LP .....	2
5	54877	. . ORIFICE, PILOT – NATURAL .....	2
5	60614	. . ORIFICE, PILOT – LP .....	2
6	51735	. BURNER MOUNTING BRACKET .....	2
7	56708	. PILOT/FLAME SENSOR BRACKET .....	2
8	FP05-010	. CONNECTOR, 3/8 TUBE TO 1/4 NPT .....	2
9	FP01-117	. STREET ELBOW, 1/4 NPT B.I. ....	2
10	14852	. KIT - 390/690 GAS MANIFOLD .....	2
11	51725	. ORIFICE, BURNER – NATURAL .....	2
11	51730	. ORIFICE, BURNER – LP .....	2
11	55452	. ORIFICE, BURNER – CE NATURAL .....	2
11	55453	. ORIFICE, BURNER – CE LP .....	2
11	56219	. ORIFICE, BURNER – PROPANE/BUTANE MIX .....	2
11	40905	. ORIFICE, BURNER – LP BUTANE MIX 70% PRO 30% BU .....	2
11	56637	. ORIFICE, BURNER – NATURAL JAPAN .....	2
12	52066	. BURNER INSHOT .....	4
13*	14221	. CONVERSION KIT – LP. TO NAT. ....	1
13*	14222	. CONVERSION KIT – NAT. TO LP. ....	1
13*	14269	. CONVERSION KIT – LP. TO NAT.-JAPAN .....	1
13*	14321	. CONVERSION KIT – LP. TO NAT.-CE .....	1
13*	14322	. CONVERSION KIT – NAT. TO LP.-CE .....	1

√ recommended parts

\*not shown

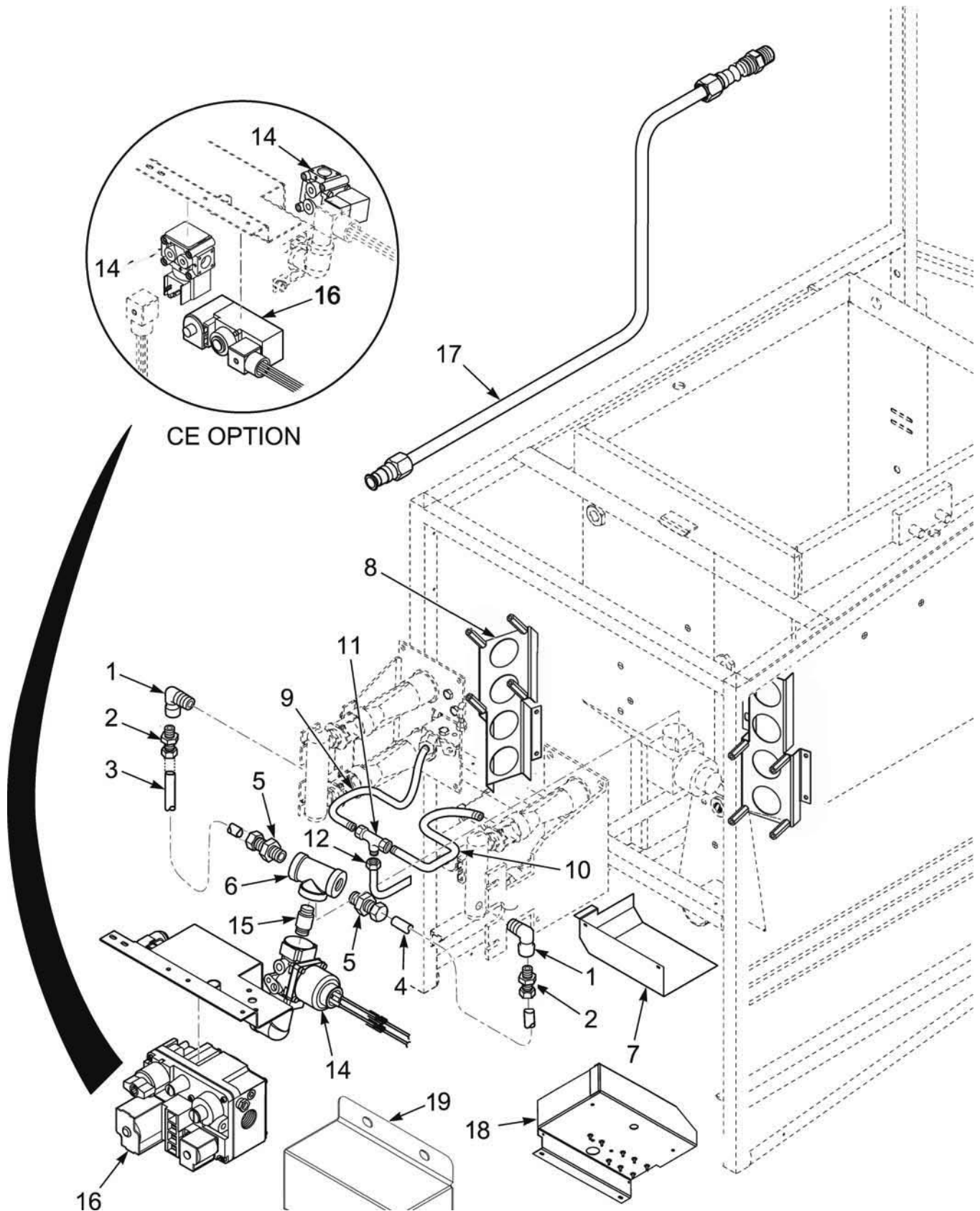

Figure 3-11. Gas Piping and Controls

Figure & Item No.	Part No.	Description	Qty.
3-11		GAS PIPING AND CONTROLS	
1	FP01-117	ELBOW .....	2
2	FP05-010	FITTING 3/8 TUBE TO 1/4 NP .....	2
3	65173	MANIFOLD TUBE .....	1
4	65173	MANIFOLD TUBE .....	1
5	FP01-115	NIPPLE – 3/8 to 1/2 NP. ....	2
6	FP01-112	1/2 NPT FEMALE PIPE TEE B.I. ....	1
7	54875	MODULE COVER .....	1
8	52785	BURNER SHIELD ASSY .....	2
	68536	BURNER SHIELD STUD ASSY .....	2
	51731	STANDOFF-BURNER .....	8
9	69441	PILOT TUBE – LEFT BURNER .....	1
10	69442	PILOT TUBE – RIGHT BURNER .....	1
11	FP05-011	TEE – 1/4 X 1/4 X 1/4 BR COMPR .....	1
12	69442	PILOT TUBE – VALVE TO TEE .....	1
13*	21452	GAS VALVE ASSY 24V – CE – NATURAL GAS .....	1
13*	21453	GAS VALVE ASSY 24V – CE – LP GAS .....	1
√ 14	38468	. SOLENOID GAS VALVE – 24V 60 HZ – NON CE .....	1
√ 14	34802	. SOLENOID GAS VALVE – 24V 50 HZ – CE .....	1
15	FP01-028	. NIPPLE, CLOSE 1/2 NPT SS 1 LG .....	1
√ 16	80761	. COMBINATION GAS VALVE – NAT.- (S/N: AP0907006 & ABOVE)-NON CE (USED IN 52476) .....	1
√ 16	80858	. COMBINATION GAS VALVE – LP.- (S/N: AP0907006 & ABOVE)NON CE .....	1
√ 16	140056	KIT-GAS VALVE- NAT/LP.- (S/N: AP0907005 & BELOW)-NON CE	1
16	140042	KIT-GAS VALVE- NAT/LP.- (S/N: AP0907005 & BELOW)-NON CE FOR UNITS BUILT WITHOUT 38468 SOLENOIDS .....	1
√ 16	21451	. 24V COMBINATION GAS VALVE – CE (USED IN 21452) .....	1
√ 16	21450	. 24V COMBINATION GAS VALVE – LP-CE (USED IN 21453) ....	1
17	52122	MAIN GAS SUPPLY LINE ASSY .....	1
17	55433	MAIN GAS SUPPLY LINE ASSY - CE (before 6-14-07) .....	1
17	76333	MAIN GAS SUPPLY LINE ASSY - CE (6-14-07 & after) .....	1
18	59189	STUD ASSY - MODULE ENCLOSURE .....	1
19	51741	WIRE COVER - GAS VALVE .....	1
20*	FP01-200	FITTING - GAS INLET BSPT .....	1

√ recommended parts

\*not shown

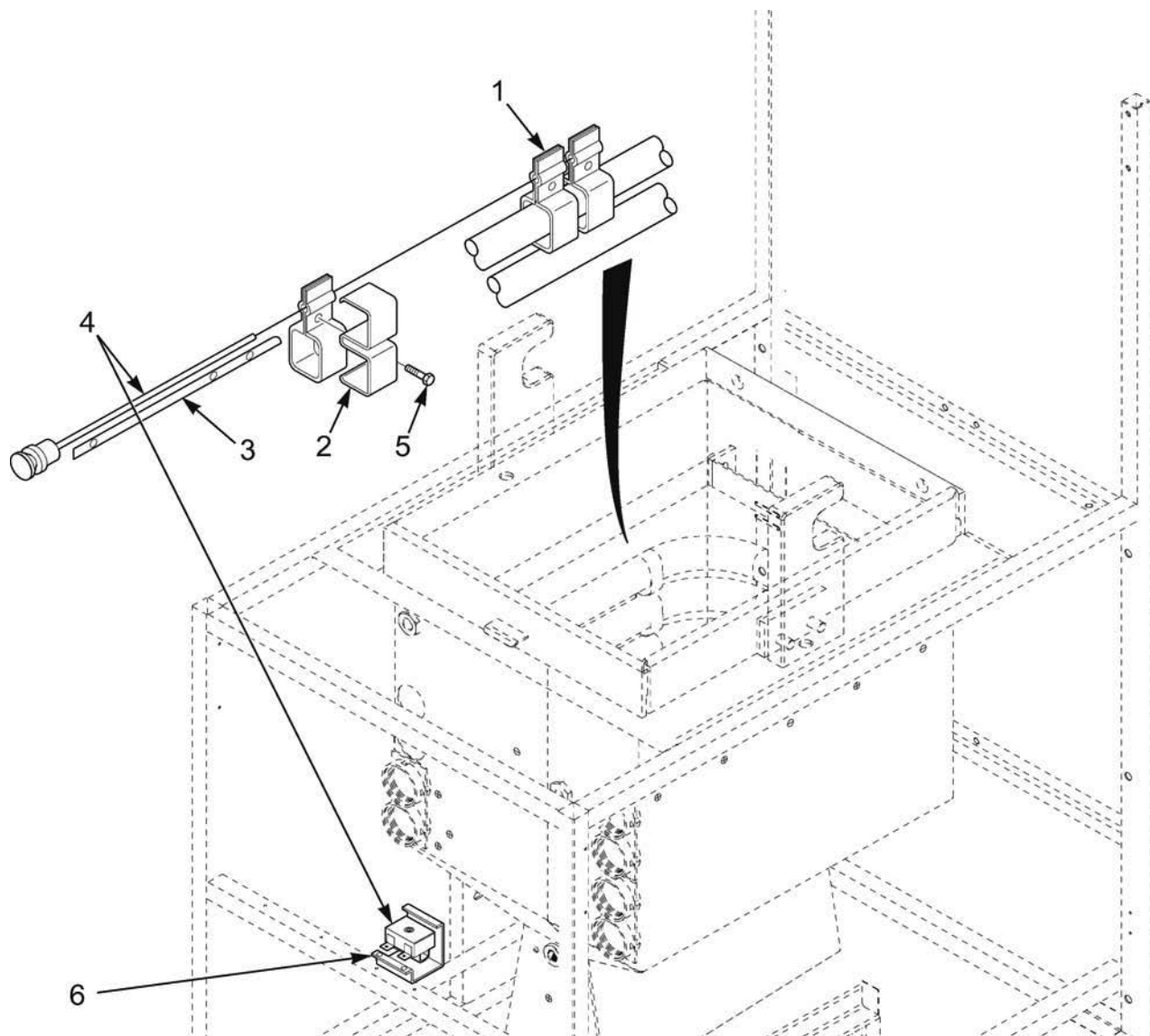

Figure & Item No.	Part No.	Description	Qty.
3-12		BURNER TUBES	
1	54480	BRACKET ASSY – HIGH LIMIT SENSING BULB .....	3
2	62051	CLIP – SPREADER – HEAT TUBE .....	6
3	53670	SPACER – HIGH LIMIT .....	1
√ 4	16738	450 HIGH LIMIT – NON CE .....	1
√ 4	60241	425 HIGH LIMIT – CE .....	1
5	SC01-211	SCREW #10-32 X 1/2 IND HEX HD S.S. ....	3
6	17216	BRACKET ASSY – HIGH LIMIT .....	1
7	16268	THERMOCOUPLE FITTING - POT (for High Limit) .....	1

√ recommended parts

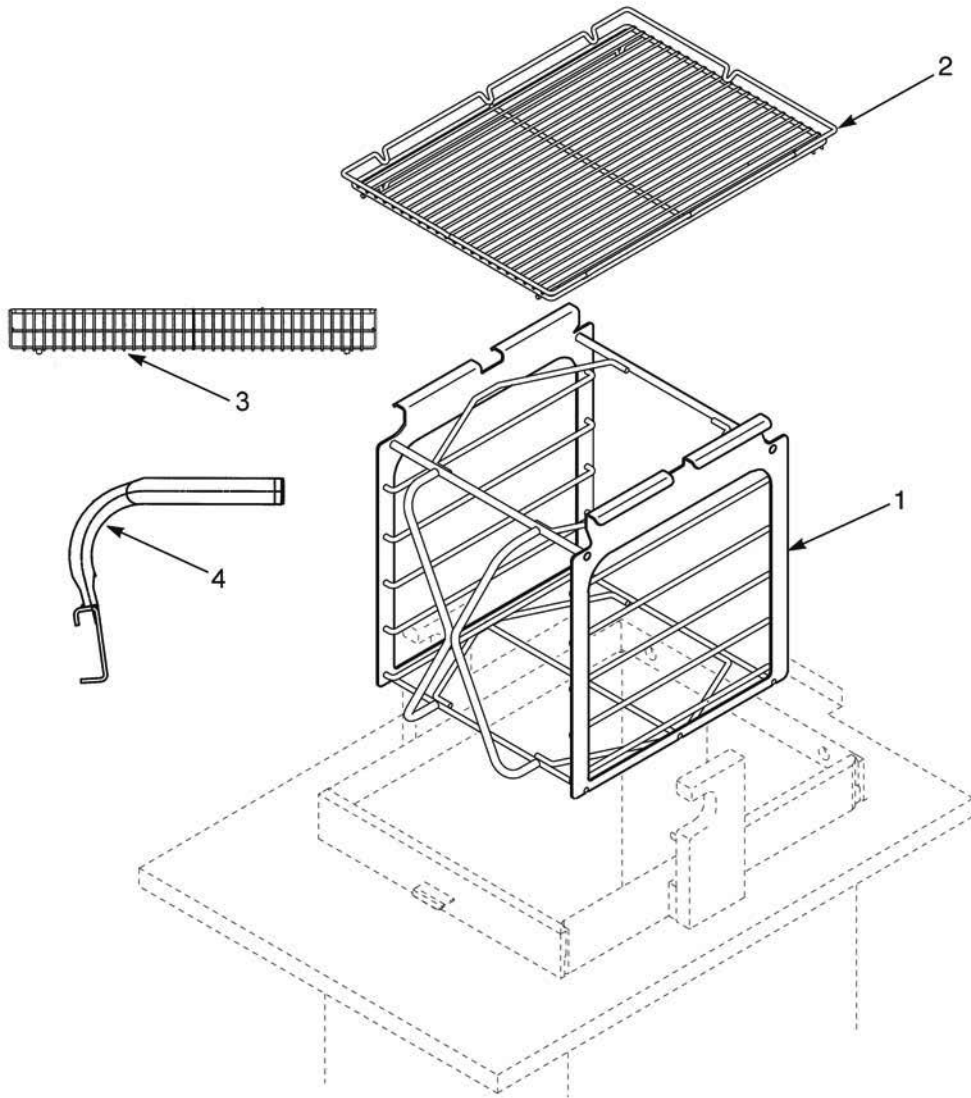

Figure & Item No.	Part No.	Description	Qty.
3-13		CARRIER AND RACKS	
1	62183	CARRIER ASSY .....	1
2	44782	RACK HALF SIZE – 8 HEAD FRYER .....	1
3	36404	WIRE BASKET - GM 8 HEAD .....	4
4	36374	ASSY - BASKET HANDLE WELD .....	1



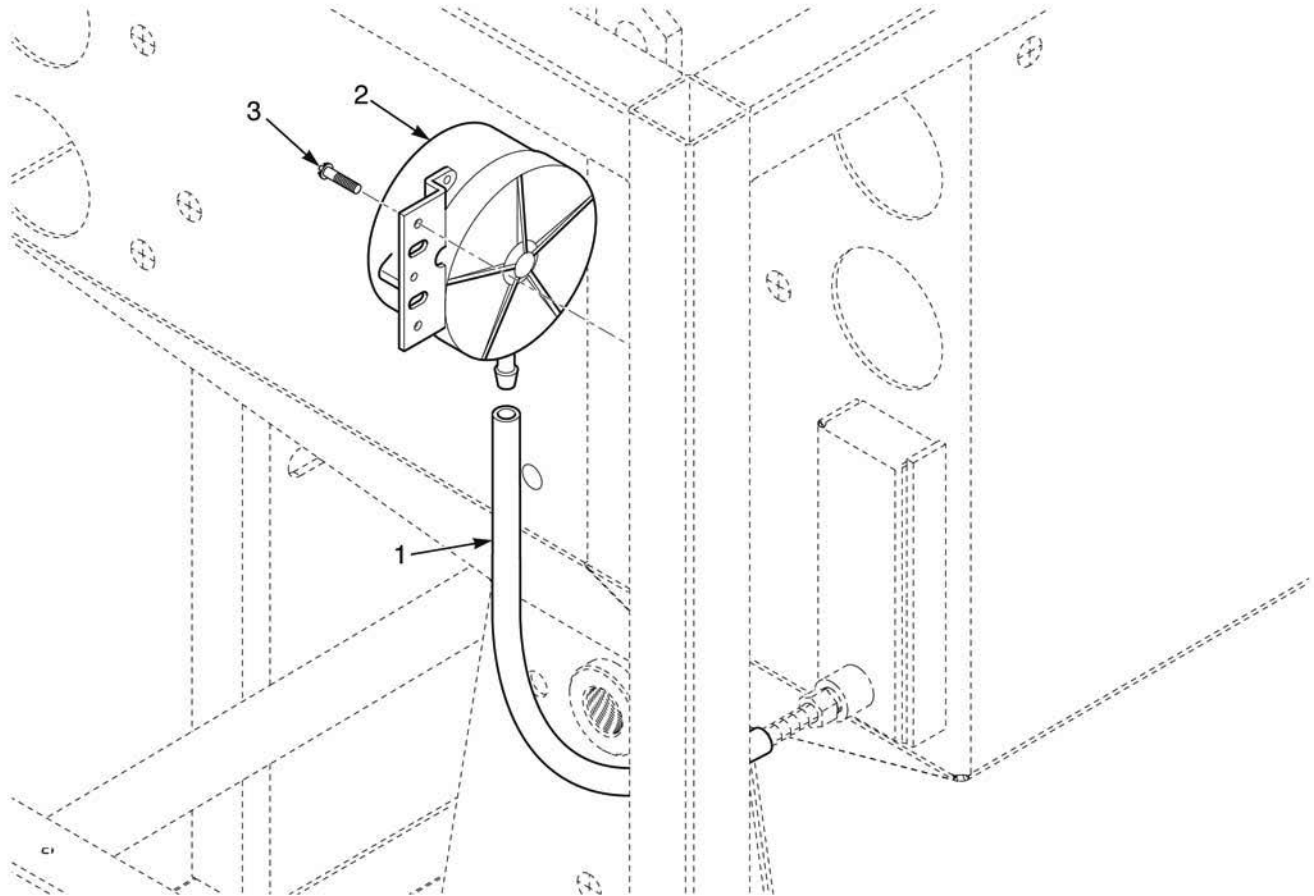
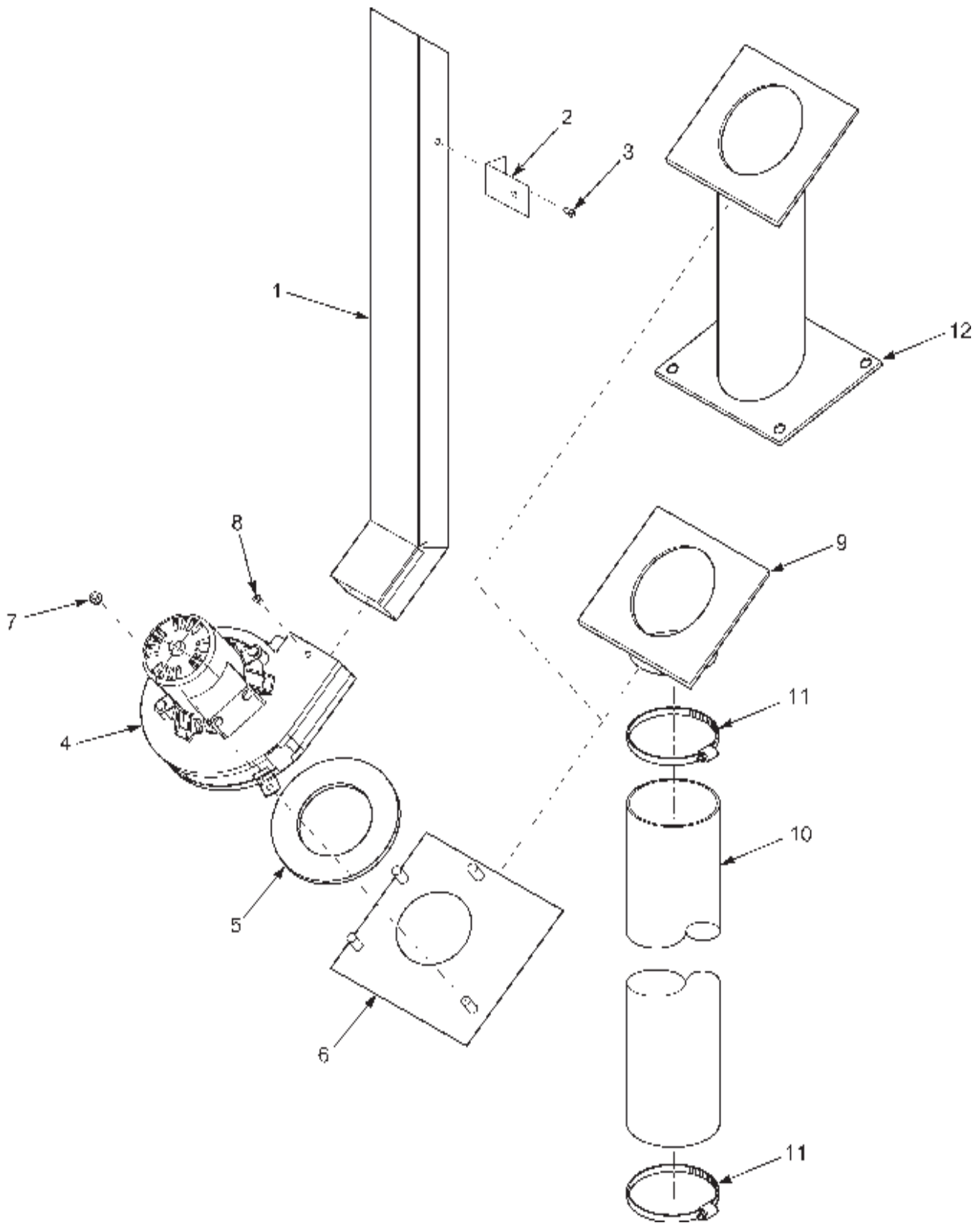

Figure & Item No.	Part No.	Description	Qty.
3-14		VACUUM SWITCH	
1	60202	TUBE-VACUUM SWITCH.....	1
√ 2	55607	VACUUM SWITCH – VERTICAL.....	1
3	SC03-005	SCREW .....	3

√ recommended parts

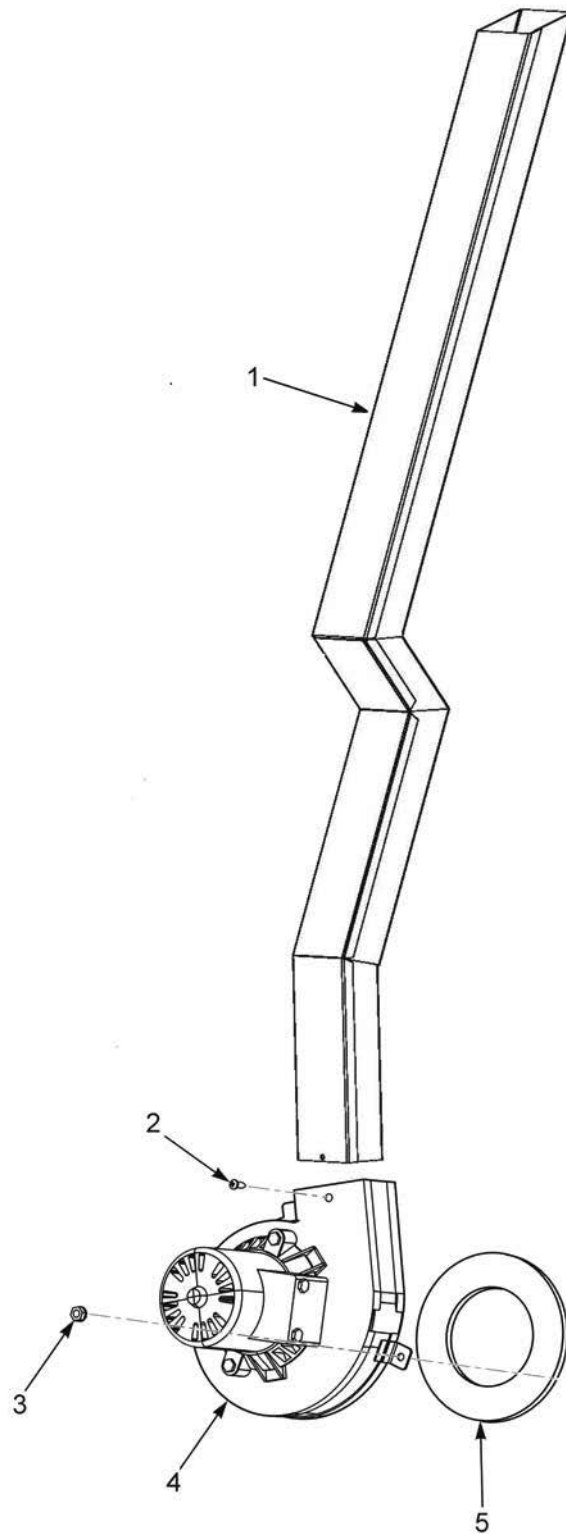

**Figure 3-15. Flue Assembly and Blower**  
**SN: BT0802002 & BELOW**

Figure & Item No.	Part No.	Description	Qty.
3-15		FLUE ASSEMBLY AND BLOWER (SN: BT0802002 & BELOW)	
1	55681	FLUE ASSY – WELDMENT .....	1
2	55783	BRACKET – FLUE RETAINING .....	1
3	SC03-005	SCREW SD #8 X 1/2 PH PHD .....	2
√ 4	14420	120V BLOWER – FLUE EXHAUST W/INSULATION..	1
√ 4	14421	100V BLOWER – FLUE EXHAUST W/INSULATION..	1
√ 4	14422	240V BLOWER – FLUE EXHAUST W/INSULATION..	1
5	21329	. INSULATION – BLOWER .....	1
6	55673	STUD ASSY – BLOWER MOUNT PLATE .....	1
7	NS02-002	NUT KEPS 1/4-20 C .....	4
8	SC02-041	#8-32 X 7/16 PH IND XTRNL TRX .....	2
9	55675	ASSY – INSUL/BLOWER INLET-NAT GAS ONLY .....	1
10	52103	DILUTION HOSE/BLOWER-NAT GAS ONLY .....	1
11	MS01-429	HOSE CLAMP – 3 9/16-4 1/2 PL-NAT GAS ONLY .....	2
12	32743	DILUTION HOSE ASSEMBLY-LP GAS ONLY .....	1
13*	14384	KIT, FLUE DUCTS – BUTANE .....	1
14*	54905	DILUTION BOX COVER - CE (0-3,999 FT) .....	1
14*	55880	DILUTION BOX COVER - LP-CE (OVER 3,999 FT)....	1
14*	55881	DILUTION BOX COVER - NAT.-CE (OVER 3,999 FT)	1

√ recommended parts

\*not shown



**Figure 3-16. Flue Assembly and Blower**  
SN: BT0802003 & ABOVE

Figure & Item No.	Part No.	Description	Qty.
3-16		FLUE ASSEMBLY AND BLOWER (SN: BT0802003 & ABOVE)	
1	70582	FLUE ASSY – WELDMENT .....	1
2	SC02-041	#8-32 X 7/16 PH IND XTRNL TRX .....	1
3	NS02-002	NUT KEPS 1/4-20 C.....	5
√ 4	14986	120V BLOWER – FLUE EXHAUST W/INSULATION..	1
√ 4	14988	100V BLOWER – FLUE EXHAUST W/INSULATION..	1
√ 4	14987	240V BLOWER – FLUE EXHAUST W/INSULATION..	1
5	21329	. INSULATION – BLOWER .....	1

√ recommended parts

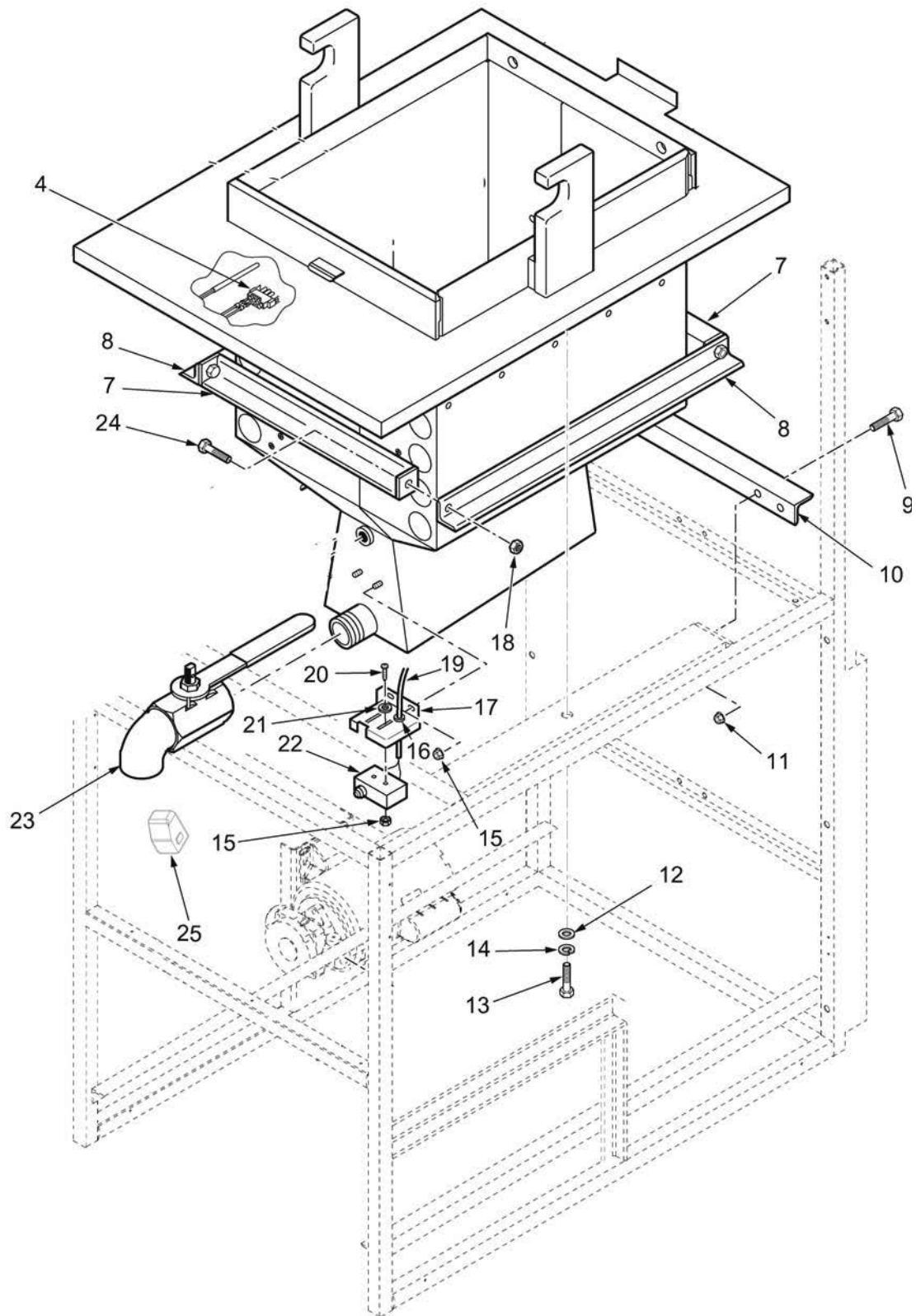

**Figure 3-16. Frypot and Drain Piping**

Figure & Item No.	Part No.	Description	Qty.
3-16		FRYPOT AND DRAIN PIPING	
√ 4	14330	KIT - PROBE ASSY – DOMESTIC (BELOW S/N FH001JC) .....	1
√ 4	140044	PROBE ASSY – (S/N FH001JC & ABOVE) .....	1
7	51792	POT BRACE, FRONT AND REAR .....	2
8	51790	POT BRACE, SIDE .....	2
9	SC01-022	SCREW 1/4-20 X 3/4 HEX HD. ....	4
10	51874	SUPPORT, REAR .....	1
11	NS02-002	NUT 1/4-20 .....	4
12	WA01-018	WASHER 3/8 FLAT .....	2
13	SC01-042	SCREW 3/8-16 X 1 HEX HD. ....	2
14	LW01-010	LOCKWASHER 3/8 SPLIT RING .....	2
15	NS02-005	NUT #6-32 HEX .....	4
16	EF02-017	STRAIN RELIEF .....	1
17	51891	BRACKET, SWITCH (SN: AP0403029 & BELOW) .....	1
17	67618	BRACKET, SWITCH (SN: AP0403030 & ABOVE) .....	1
18	NS01-016	NUT 7/16-14 HEX .....	4
19	52519	CORD ASSY., DRAIN INTERLOCK .....	1
20	SC01-058	SCREW #6-32 X 1 PH. PAN HD. ....	2
21	WA01-006	WASHER #6 .....	2
√ 22	54228	DRAIN SWITCH W/BOOT .....	1
23	21355	DRAIN VALVE W/EXTENSION (BELOW SN: AP0401001) .....	1
23	66446	DRAIN VALVE W/EXTENSION (SN: AP0401001 & ABOVE) .....	1
24	SC01-217	SCREW 7/16-14 X 1-1/4 HEX HD. ....	4
25	67617	BRACKET - MICROSWITCH TRIGGERING .....	1
26*	76683	(SN: BT0802002 & BELOW) PLATE - D/I SWITCH COVER GAS .....	1

√ recommended parts

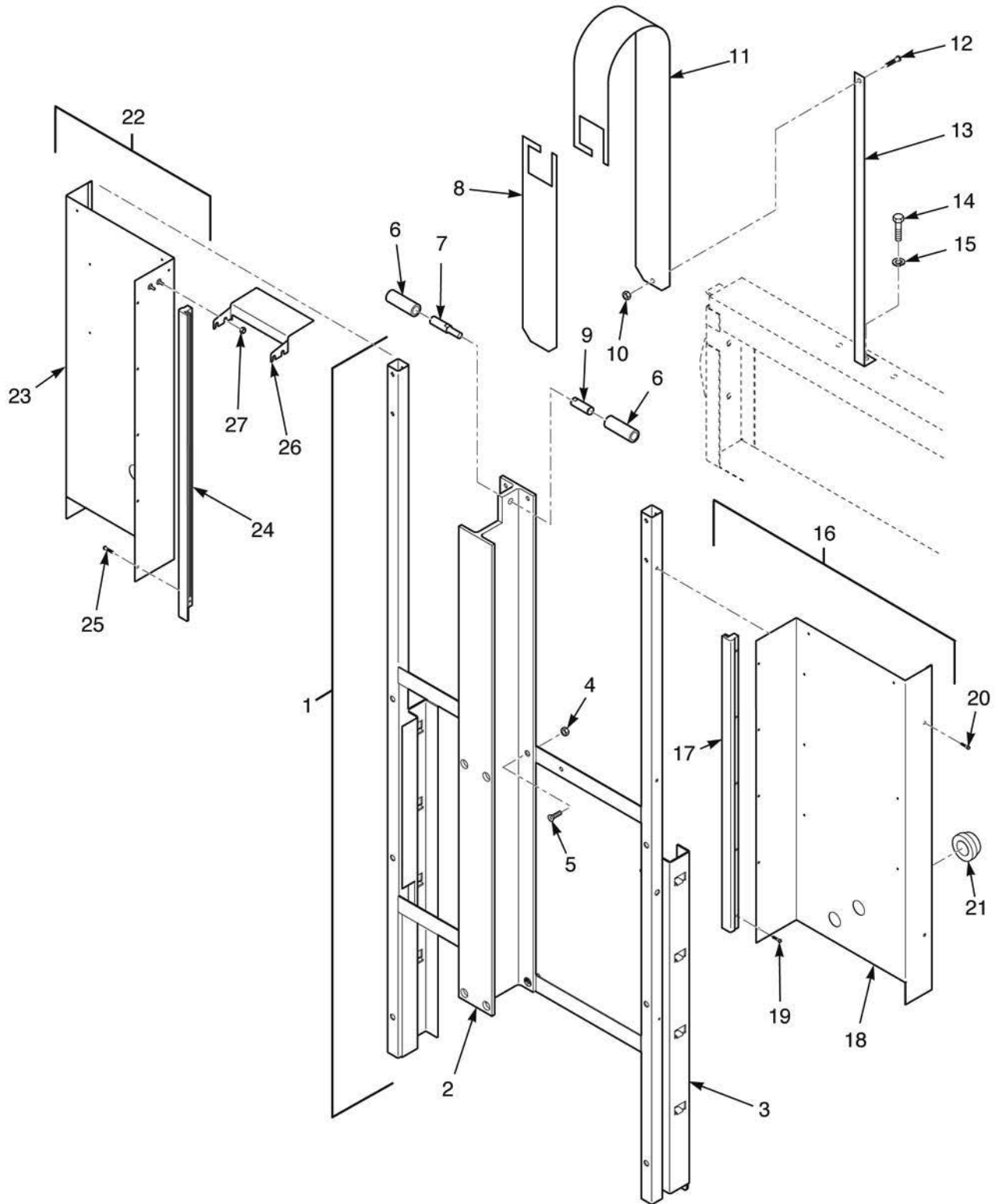
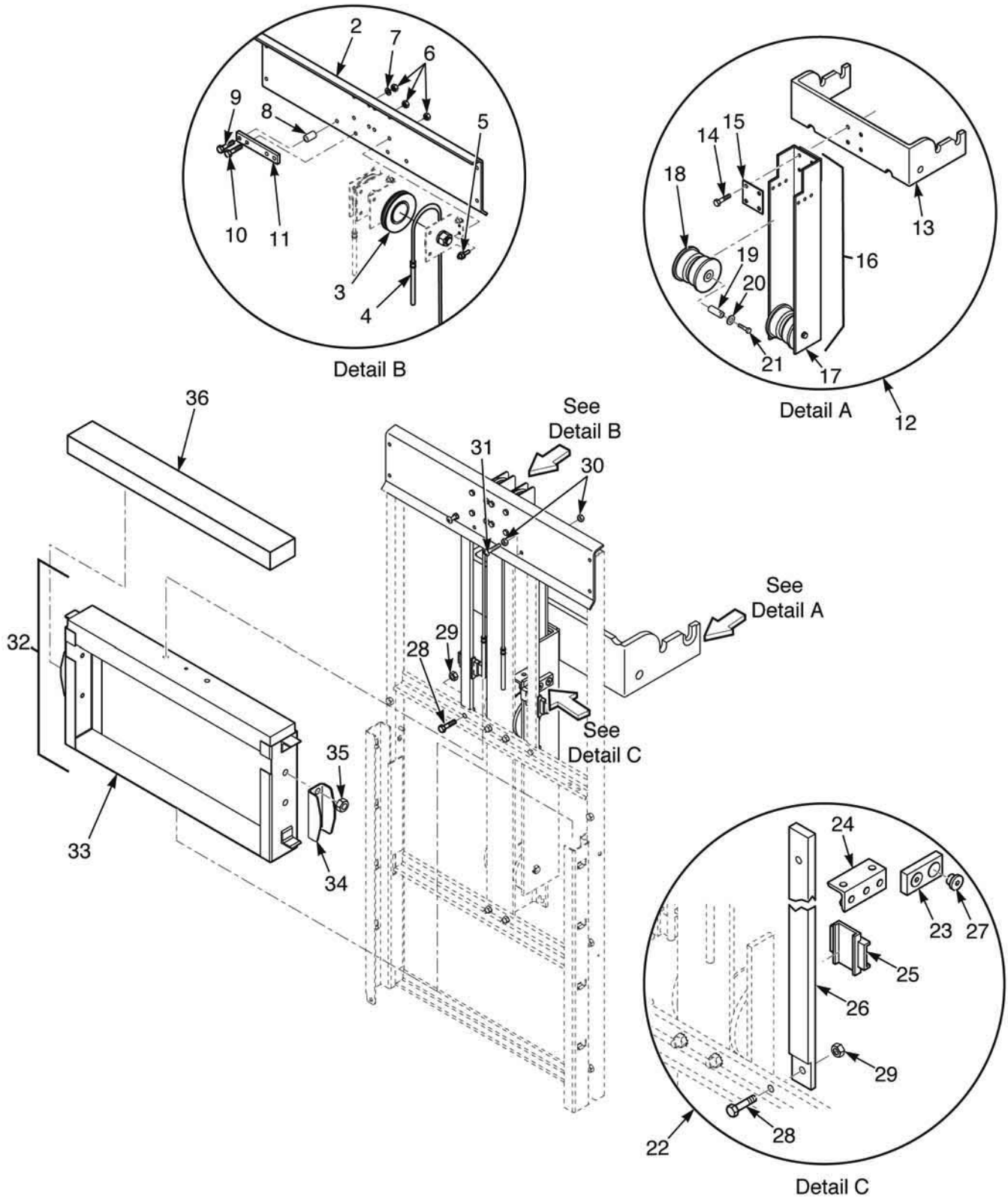

**Figure 3-17. Lift Beam and Shrouds  
SN: BT0802002 & BELOW**



Figure & Item No.	Part No.	Description	Qty.
3-17		LIFT BEAM AND SHROUDS <b>(SN: BT0802002 &amp; BELOW)</b>	
1	55678	ASSY – I-BEAM/LIFT FRAME .....	1
2	51548	. LIFT I-BEAM .....	1
3	55677	. LIFT FRAME ASSY – WELDMENT .....	1
4	NS02-008	.. NUT .....	4
5	SC01-212	.. SCREW .....	4
6	52474	STOP - LIFT U-CHANNEL .....	1
7	51595	STOP PIN MALE .....	1
8	56825	LIFT STRAP FILLER – LOWER .....	1
9	51594	STOP PIN – FEMALE .....	1
10	NS02-007	NUT .....	1
11	56824	LIFT STRAP FILLER – UPPER .....	1
12	SC01-034	SCREW – PH .....	1
13	52177	LIFT STRAP .....	1
14	SC01-052	BOLT .....	1
15	LW01-002	LOCK WASHER .....	1
16	52784	ASSY – FRONT SHROUD/RIGHT .....	1
17	21345	. SLIDE GUIDE – RIGHT .....	1
18	52482	. WELDMENT – FRONT SHROUD/RIGHT .....	1
19	SC01-023	. SCREW #6-32 X 1/4 PH RHD C .....	5
20	SC03-005	SCREW – PH .....	4
21	16804	UMBRELLA GROMMET .....	3
22	52521	ASSY – FRONT SHROUD/LEFT .....	1
23	62087	. ASSY – FRONT SHROUD, LEFT STUD .....	1
24	21346	. SLIDE GUIDE – LEFT .....	1
25	SC01-023	. SCREW #6-32 X 1/4 PH RHD C .....	5
26	62091	SHROUD SPACER/PULLY GUARD .....	1
27	NS02-005	NUT .....	4
28	14218*	SINGLE TO DOUBLE LIFT STRAP KIT .....	1

\*not shown



**Figure 3-18. Counterweight and Pulley System  
SN: BT0802002 & BELOW**

Figure & Item No.	Part No.	Description	Qty.
3-18		COUNTERWEIGHT AND PULLEY SYSTEM (SN: BT0802002 & BELOW)	
1	52475	PULLEY ASSY .....	1
2	51677	. PULLEY PLATE .....	1
3	35962	. BRACKET/WHEEL ASSY .....	2
√ 4	35207	. CABLE .....	2
5	SC01-022	. SCREW 1/4-20 X 3/4 HEX HD C .....	8
6	NS02-002	. NUT KEPS 1/4-20 C .....	12
7	WA01-002	WASHER .....	2
8	51590	SPACER .....	2
9	SC01-104	BOLT .....	2
10	SC01-022	BOLT .....	2
11	51591	I BEAM - PULLEY BRACE .....	1
12	54494	ASSY - LID ARM/U-CHANNEL .....	1
13	51692	. MACHINED - ARM - LID LIFT .....	1
14	55883	. SCREW 3/8-16 X 1-1/2 FT HH G .....	4
15	55598	. TORQUE PLATE - U-CHANNEL .....	1
16	54493	. ASSY - LIFT U-CHANNEL .....	1
17	51549	.. LIFT U-CHANNEL .....	1
18	66715	.. WHEEL - TRUCK .....	4
19	51593	.. SPINDLE - U CHANNEL WHEEL .....	4
20	LW01-001	.. LOCKWASHER SPLIT RING 3/8 ID .....	4
21	SC01-081	.. SCREW 3/8-24 X 3/4 HEX HD S .....	4
22	55873	STABILIZER COMPONENTS - ASSY .....	1
23	59113	. SUPPORT ARM - STABILIZER .....	2
24	51553	. ASSY - CABLE MOUNTING BRACKET .....	2
25	59112	. SLIDE - STABILIZER .....	2
26	59111	. BRACE - STABILIZER .....	2
27	SC01-226	. 5/16-18 X 1-1/4 FHD CAP SCREW .....	6
28	SC01-146	. SCREW 1/4-20 X 3/4 HEX HD C .....	2
29	NS02-002	. NUT KEPS 1/4-20 C .....	4
30	NS01-012	. NUT HEX 1/4-20 C .....	2
31	SC01-232	. 1/4-20 X 2.00 TRUSS HD PH ZI .....	2
32	54492	ASSY - CARRIAGE, WEIGHT .....	1
33	52118	. ASSY - WEIGHT BRACKET, STUD .....	1
34	62018	. GUIDE - COUNTER WEIGHT .....	2
35	NS02-002	. NUT KEPS 1/4-20 C .....	4
36	36627	COUNTERWEIGHT BAR .....	4

√ recommended parts

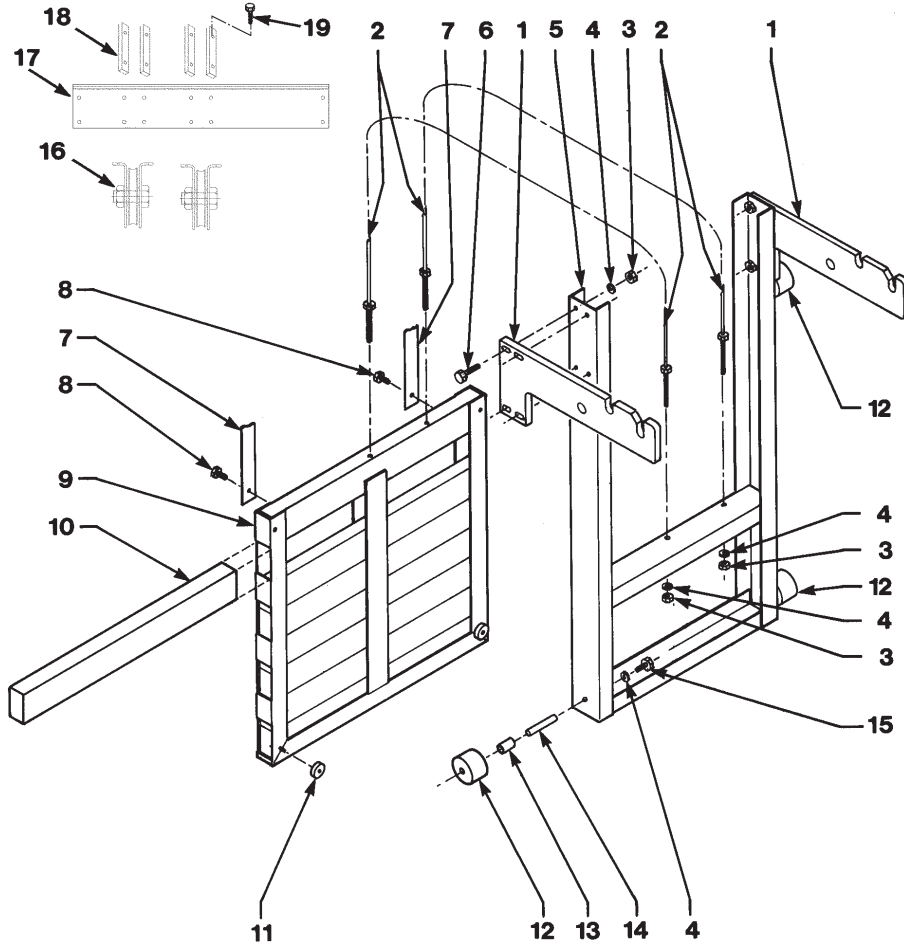

Figure & Item No.	Part No.	Description	Qty.
3-21		<b>COUNTERWEIGHT SYSTEM (SN: BT0802003 &amp; ABOVE)</b>	
1	35026	ARM, LID SUPPORT .....	2
√ 2	35207	CABLE .....	2
3	NS01-025	NUT, HEX 5/16-18 SS .....	10
4	LW01-010	WASHER, 3/8 SPLIT RING SS .....	10
5	35092	CARRIAGE .....	1
6	SC01-069	SCREW, 3/8-16 X 1-1/2 HEX HD S2P .....	8
7	36839	SLIDE .....	2
8	SC01-042	SCREW, 3/8-16 X 1 HEX C .....	2
9	36625	WELD ASSEMBLY, C/W CARRIAGE .....	1
10	36627	COUNTERWEIGHT BAR .....	7
11	36626	SPACER, C/W FRAME .....	2
12	37362	WHEEL, CARRIAGE .....	4
13	37363	SPACER, CARRIAGE WHEEL .....	4
14	37364	SPINDLE .....	4
15	SC01-081	SCREW, 3/8-24 X 3/4 HEX HD SS .....	4
16	35962	BRACKET/WHEEL ASSY. ....	2
17	36561	BRACE, TOP FRAME .....	1
18	35964	PLATE, SUPPORT PULLEY .....	4
19	SC01-132	1/2-20 X 5/8 SOC HD CAP SCREW .....	8

√ recommended parts

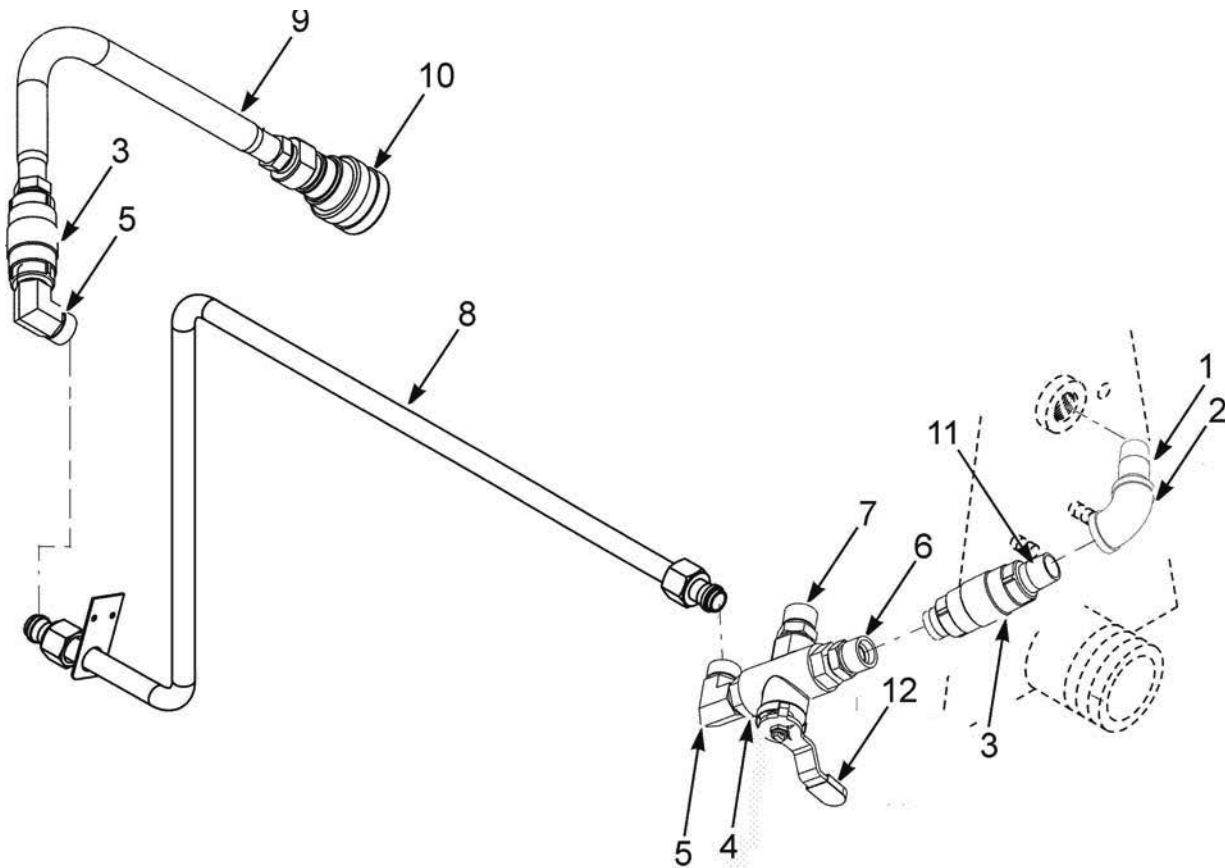

Figure & Item No.	Part No.	Description	Qty.
3-19	14639	OPTIONAL DIRECT-CONNECT KIT .....	1
		(SN: LH029JC and above only)	
1	FP01-175	NIPPLE - 3/4 NPT X 2.5 LG SS .....	1
2	FP01-176	ELBOW - 3/4 SS .....	1
3	21800	VALVE - 3/4 CHECK .....	2
4	68510	VALVE - 3/4 DIVERTER W/O HANDLE .....	1
5	FP01-169	CON - 90 MALE 3/4 TUBE 3/4 NPT .....	2
6	16282	NIPPLE - 3/4 CLOSE .....	1
7	FP01-170	CON - STR MALE 3/4 NPT .....	1
8	67692	ASSY - DIRECT CONN TUBE 8 HEAD .....	1
9	21753	HOSE - SHORTENING DISCARD .....	1
10	21612	DISCONNECT - FEMALE .....	1
11	FP02-060	NIPPLE - 3/4 SS CLOSE .....	1
12	68126	HANDLE - 8 HEAD DIRECT CONNECT .....	1

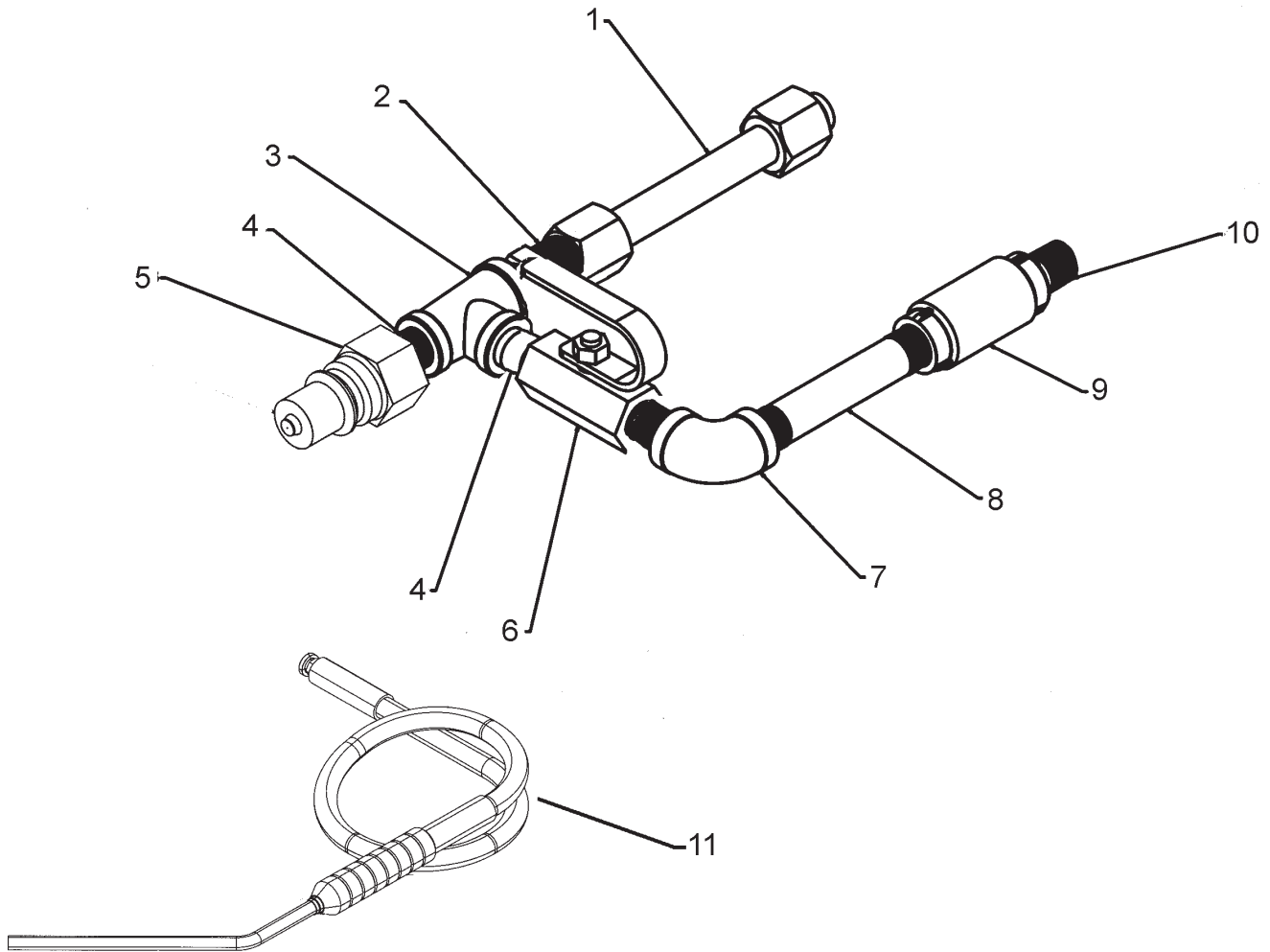

Figure & Item No.	Part No.	Description	Qty.
3-20A	14259	OPTIONAL RINSE HOSE KIT .....	1
		(SN: LH015JC and below)	
1	56981	ASSY - PUMP TO POT TUBE .....	1
2	16807	FITTING CONNECTOR - MALE .....	1
3	17306	PIPE TEE FITTING .....	1
4	FP02-024	NIPPLE - 3/8 NPT CLOSE B.I. ....	2
5	17334	RINSE HOSE DISCONNECT - MALE .....	1
6	59185	VALVE - FILTER - SM. "C" HANDLE .....	1
7	FP01-114	STREET ELBOW - 3/8 NPT B.I. ....	1
8	FP01-116	NIPPLE - 3/8 NPT X 4" LG B.I. ....	1
9	35472	CHECK VALVE - PRESSURE .....	1
10	FP02-007	NIPPLE - 3/8 X 1-1/2 .....	1
11	03003	DETACHABLE HOSE ASSEMBLY .....	1

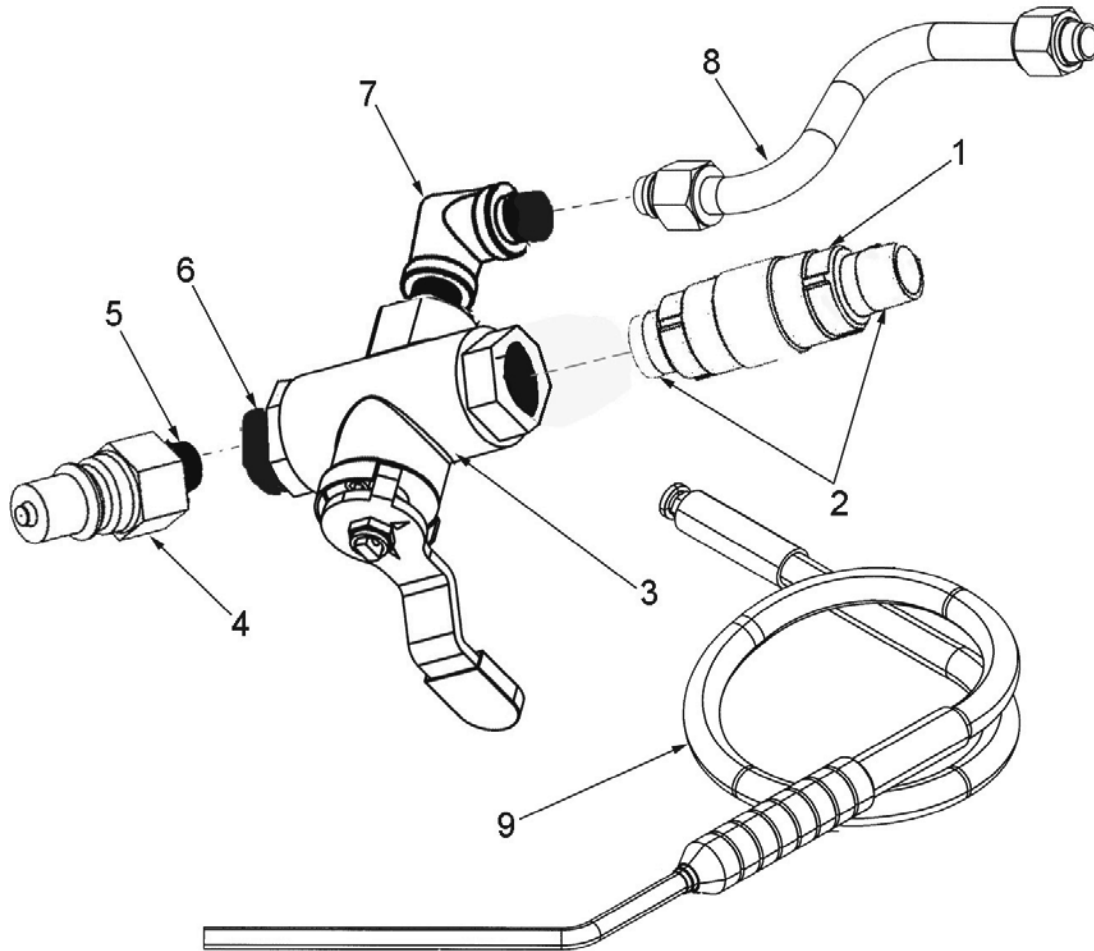

Figure & Item No.	Part No.	Description	Qty.
3-20B		OPTIONAL RINSE HOSE ASSEMBLY (SN: LH016JC and above)	
1	21800	VALVE - 3/4 CHECK .....	1
2	16282	NIPPLE - 3/4 CLOSE .....	2
3	66697	VALVE - 3/4 DIVERTER .....	1
4	17334	RINSE HOSE DISCONNECT - MALE .....	1
5	FP02-024	NIPPLE - 3/8 NPT CLOSE B.I. ....	1
6	FP01-143	BUSHING 3/4 X 3/8 B.I. ....	1
7	FP01-169	CON - 90 MALE 3/4 TUBE 3/4 NPT .....	1
8	66810	ASSY - 391/691 FLTR RINSE TUBE .....	1
9	03003	DETACHABLE HOSE ASSEMBLY .....	1