



**Henny Penny
Pressure Fryer-Electric
Model PFE-590
Model PFE-592**

TECHNICAL MANUAL

TABLE OF CONTENTS

Section		Page
Section 1.	TROUBLESHOOTING.....	1-1
	1-1 Introduction.....	1-1
	1-2 Safety.....	1-1
	1-3 Troubleshooting.....	1-2
	1-4 Error Codes.....	1-11
Section 2.	MAINTENANCE.....	2-1
	2-1 Introduction.....	2-1
	2-2 Maintenance Hints.....	2-1
	2-3 Preventive Maintenance.....	2-1
	2-4 High Temperature Limit Control.....	2-2
	2-5 Fuse Holders.....	2-4
	2-6 Power/Pump Switch.....	2-5
	2-7 Temperature Probe Replacement.....	2-6
	2-8 Complete Control Panel - Henny Penny.....	2-7
	2-9 Pressure Regulation.....	2-7
	2-10 Tilting the Lid Upright.....	2-8
	2-11 Reversing the Lid Gasket.....	2-8
	2-12 Lid Counterweight Cables.....	2-9
	2-13 Pressure Pad.....	2-10
	2-14 Lid Adjustment.....	2-11
	2-15 Solenoid Valve.....	2-12
	2-16 Deadweight Valve.....	2-14
	2-17 Removal & Cleaning of Safety Relief Valve.....	2-15
	2-18 Pressure Gauge.....	2-16
	2-19 Contactors.....	2-17
	2-20 Heating Elements.....	2-19
	2-21 Drain Microswitch.....	2-22
	2-22 Drain Valve and Extension.....	2-23
	2-23 Nylatron Strips Replacement.....	2-24
	Wiring Diagrams.....	2-26
Section 3.	PARTS INFORMATION.....	3-1
	3-1 Introduction.....	3-1
	3-2 Genuine Parts.....	3-1
	3-3 When Ordering Parts.....	3-1
	3-4 Prices.....	3-1
	3-5 Delivery.....	3-1
	3-6 Warranty.....	3-1
	3-7 Recommended Spare Parts for Distributors.....	3-1
	3-8 Index of Parts Lists Illustrations.....	3-2

SECTION 1. TROUBLESHOOTING

1-1. INTRODUCTION

This section provides troubleshooting information in the form of an easy to read table.

If a problem occurs during the first operation of a new fryer, recheck the installation per the Installation Section of this manual.

Before troubleshooting, always recheck the operation procedures per Section 3 of this manual.

1-2. SAFETY

Where information is of particular importance or safety related, the words DANGER, WARNING, CAUTION, and NOTICE are used. Their usage is described below.



SAFETY ALERT SYMBOL is used with DANGER, WARNING, or CAUTION which indicates a personal injury type hazard.



NOTICE is used to highlight especially important information.



CAUTION used without the safety alert symbol indicates a potentially hazardous situation which, if not avoided, may result in property damage.



CAUTION indicates a potentially hazardous situation which, if not avoided, may result in minor or moderate injury.



WARNING indicates a potentially hazardous situation which, if not avoided, could result in death or serious injury.



DANGER INDICATES AN IMMINENTLY HAZARDOUS SITUATION WHICH, IF NOT AVOIDED, WILL RESULT IN DEATH OR SERIOUS INJURY.

1-3. TROUBLESHOOTING

To isolate a malfunction, proceed as follows:

1. Clearly define the problem (or symptom) and when it occurs.
2. Locate the problem in the Troubleshooting table.
3. Review all possible causes. Then, one-at-a-time work through the list of corrections until the problem is solved.
4. Refer to the maintenance procedures in the Maintenance Section to safely and properly make the checkout and repair needed.



If maintenance procedures are not followed correctly, injuries and/or property damage could result.

Problem	Cause	Correction
COOKING SECTION		
Product color not correct: A. Too dark	<ul style="list-style-type: none"> • Temperature too high • Faulty temperature probe • Shortening too old • Shortening too dark • Breeding product too far in advance 	<ul style="list-style-type: none"> • Check temperature setting in the program mode; see Programming Section in Operator's Manual • Remove and replace temperature probe • Change shortening • Filter shortening • Change shortening • Bread product closer to actual frying period
B. Too light	<ul style="list-style-type: none"> • Temperature too low • Fryer incorrect preheat • Slow fryer heat-up/recovery • Wrong cook button pushed. 	<ul style="list-style-type: none"> • Check temperature setting • Remove and replace temperature probe • Allow proper preheat time • Faulty heating element • Be sure to select the correct amount of product to be cooked
C. Product greasy	<ul style="list-style-type: none"> • Shortening old • Temperature too low • Faulty temperature probe • Frypot overloaded • Product not removed from frypot immediately after depressurization 	<ul style="list-style-type: none"> • Replace shortening • Check temperature setting • Temperature not recovered when product was dropped in frypot • Remove and replace defective temperature probe • Reduce cooking load • Remove product from frypot immediately after depressurization

Problem	Cause	Correction
COOKING SECTION (Continued)		
D. Spotted product	<ul style="list-style-type: none"> • Improper separation of the product • Breading not uniform on the product • Burned breading particles on product • Product sticking together 	<ul style="list-style-type: none"> • Load product into racks properly • Sift breading regularly • Separate product during breading • Filter the shortening more frequently • Separate product prior to pressure cooking
E. Dryness of product	<ul style="list-style-type: none"> • Moisture loss prior to cooking • Overcooking the product • Low operating pressure • Wrong cook button pushed 	<ul style="list-style-type: none"> • Use fresh products • Reduce cooking time • Reduce cooking temperature • Check pressure gauge reading, check for pressure leaks • Be sure to select the correct amount of product to be cooked
Product flavor (taste): A. Salty taste B. Burned taste C. Bland taste	<ul style="list-style-type: none"> • Breading mixture is too salty • Incorrect choice of breading • Burned shortening favor • Frypot not properly cleaned • Raw product not fresh • Breading mixture incorrect for product (spice content too low) • Cooking temperature too high (spice flavors lost) 	<ul style="list-style-type: none"> • Sift breading after each use • Incorrect breading mixture • Discard old breading • Use breading designed for the desired product • Replace shortening • Drain and clean frypot • Use fresh raw product • Use breading designed for desired product • Check temperature

Problem	Cause	Correction
COOKING SECTION (Continued)		
D. Rancid taste	<ul style="list-style-type: none"> • Shortening too old • Infrequent filtering • Non-compatible products cooked within the same shortening. • Raw product not fresh 	<ul style="list-style-type: none"> • Replace shortening, and follow recommended care and use of shortening • Replace shortening and follow recommended care and use of shortening • Replace shortening • Use compatible products, and follow recommended care and use of shortening • Use fresh product
General: A. Meat separation from bone	<ul style="list-style-type: none"> • Incorrect meat cut • Overcooking • Product not fresh 	<ul style="list-style-type: none"> • Use correct meat cutting procedures • Check cooking time • Use fresh product
B. Bone color not proper	<ul style="list-style-type: none"> • Using frozen product (black bone) • Improper processing of product (black bone) • Product not thoroughly cooked (red bone) 	<ul style="list-style-type: none"> • Use fresh product • Use proper processing procedure for product • Check cooking time • Check cooking temperature
C. Breading falls off	<ul style="list-style-type: none"> • Incorrect breading procedures • Product partially frozen 	<ul style="list-style-type: none"> • Use correct breading procedure • Thoroughly thaw the product, before breading
D. Product sticking together	<ul style="list-style-type: none"> • Product breaded too long prior to cooking • Improper loading procedure • Wrong cook button pushed 	<ul style="list-style-type: none"> • Refer to breading and frying instructions • Properly load product per loading procedures • Select correct amount of product to be cooked

Problem	Cause	Correction
POWER SECTION		
With switch in POWER position, the fryer is completely inoperative (NO POWER)	<ul style="list-style-type: none"> • Open circuit 	<ul style="list-style-type: none"> • Check to see that unit is plugged in • Check the breaker or fuse at supply box • Check voltage at wall receptacle • Check MAIN POWER switch; replace if defective • Check cord and plug • Check 15 amp fuses
PRESSURE SECTION		
Pressure will not exhaust at end of cook cycle	<ul style="list-style-type: none"> • Exhaust line from solenoid valve to exhaust tank clogged 	<ul style="list-style-type: none"> • Turn unit off and allow fryer to cool to release pressure from frypot; clean all pressure lines, exhaust stacks, and exhaust tank
Operating pressure too high	<ul style="list-style-type: none"> • Solenoid valve clogged • Deadweight clogged • Exhaust line to stack clogged 	<ul style="list-style-type: none"> • Check and clean solenoid valve per maintenance section on solenoid valve • Turn unit off and allow fryer to cool to release pressure from frypot; remove dead weight and clean • Clean exhaust line to stack



DO NOT OPERATE UNIT IF HIGH PRESSURE CONDITIONS EXIST; SEVERE INJURIES AND BURNS WILL RESULT. PLACE THE POWER/PUMP SWITCH IN THE OFF POSITION IMMEDIATELY. RELEASE THE PRESSURE BY ALLOWING UNIT TO COOL. THE PRESSURE WILL THEN DROP. DO NOT RESUME USE OF UNIT UNTIL CAUSE OF HIGH PRESSURE HAS BEEN FOUND AND CORRECTED.

Problem	Cause	Correction
PRESSURE SECTION (Continued)		
Pressure does not build	<ul style="list-style-type: none"> • Not enough product in fryer or product not fresh • Metal shipping spacer not removed from dead weight • Lid open or not latched • Solenoid valve leaking or not closing • Dead weight valve leaking • Pressure not programmed • Lid gasket leaking • Safety relief valve leaking • Pressure pad broken or crushed 	<ul style="list-style-type: none"> • Place proper quantity of fresh product within frypot to generate steam • Remove shipping spacer. See Unpacking Section of Operator's Manual • Close and latch lid • Check or clean solenoid valve per maintenance section on the solenoid valve • Repair per maintenance section on deadweight valve • Check programming • Reverse gasket or lid needs adjusted; see Reversing the Lid Gasket and Lid Adjustment Sections • Check and replace if necessary per maintenance section on the safety relief valve • Replace pressure pads

Problem	Cause	Correction
HEATING OF SHORTENING SECTION		
Shortening will not heat	<ul style="list-style-type: none"> • Blown fuse or tripped • Blown fuse in PC board • Faulty POWER/PUMP switch. • Faulty cord and plug • Faulty drain switch • Faulty PC Board • Faulty high limit control switch • Drain valve open • Possible faulty temperature probe • Faulty contactor 	<ul style="list-style-type: none"> • Reset breaker or replace fuse circuit breaker at supply box or control panel • Replace glass fuse in board • Check POWER/PUMP switch per maintenance section on the POWER/PUMP switch • Check cord and plug • Check power at receptacle • Check drain switch per maintenance section on drain switches • Remove and replace control panel • Check high limit control switch per maintenance section on the high limit • Close drain valve • Replace temperature probe • Check contactor per maintenance section on contactors

Problem	Cause	Correction
HEATING OF SHORTENING SECTION (Continued)		
Heating of shortening too slow	<ul style="list-style-type: none"> • Low or improper voltage • Weak or burnt out element(s) • Points in contactor bad • Wire(s) loose • Burnt or charred wire connection 	<ul style="list-style-type: none"> • Use a meter and check the receptacle against data plate • Check heating element(s) per Heating Elements Section • Check contactor per Heating Contactors Section • Tighten • Replace wire and clean connectors
Shortening overheating	<ul style="list-style-type: none"> • Programming wrong • Faulty PC board • Faulty temperature probe • Check contactor for not opening 	<ul style="list-style-type: none"> • Check temperature setting in the program mode • Remove and replace control panel • Remove and replace temperature probe • Check faulty contactor per Heating Contactors Section

Problem	Cause	Correction
SHORTENING FOAMING/DRAINING SECTION		
Foaming or boiling over of shortening	<ul style="list-style-type: none"> • Water in shortening • Condensation line stopped up • Improper or bad shortening • Improper filtering • Cold zone full of cracklings • Improper rinsing after cleaning the fryer 	<ul style="list-style-type: none"> • At end of a Cook Cycle, drain shortening and clean frypot; add fresh shortening • Remove and clean condensation line • Use recommended shortening • Refer to the procedure covering filtering the shortening • Filter shortening • Clean and neutralize the frypot; rinse with vinegar to remove the alkaline, then rinse with hot water and dry frypot
Shortening will not drain from frypot	<ul style="list-style-type: none"> • Drain valve clogged with crumbs 	<ul style="list-style-type: none"> • Open valve - push cleaning rod through drain opening from inside of frypot
Shortening leaking through drain valve	<ul style="list-style-type: none"> • Obstruction in drain • Faulty drain valve 	<ul style="list-style-type: none"> • Remove obstruction • Replace drain valve

1-4. ERROR CODES

In the event of a control system failure, the digital display shows an error message. These messages are coded: “E04”, “E05”, “E06”, “E41”. A constant tone is heard when an error code is displayed, and to silence this tone, press any of the product buttons.

DISPLAY	CAUSE	PANEL BOARD CORRECTION
“E04”	Control board overheating	Turn switch to OFF position, then turn switch back to ON; if display still shows “E04”, the board is getting too hot; check for signs of overheating behind the control panel; once panel cools down the controls should return to normal; if “E04” persists, replace the control
“E05”	Shortening overheating	Turn switch to OFF position, then back to ON; if display shows “E05”, the heating circuits and temperature probe should be checked; once the unit cools down, the controls should return to normal; if “E05” persists, replace the controls
“E06”	Temperature probe failure	Turn switch to OFF position, then back to ON; if the display shows “E06”, the temperature probe should be checked; once the temperature probe is repaired, or replaced, controls should return to normal; if “E06” persists, replace the controls
“E41”	Programming Failure	Turn switch to OFF position, then back to ON. If display shows “E41”, the control should be re-initialized (see programming section); if the error code persists, replace the control panel.
“E71”	Pump motor relay failure or wiring problem	Replace relay if contacts are stuck closed; check wiring on POWER/PUMP switch, or wall receptacle; L1 and N may be reversed

1-4. ERROR CODES (Continued)

CE Only - Along with the error codes from page 1-11, CE units have the following self-diagnostic error codes:

DISPLAY	CAUSE	PANEL BOARD CORRECTION
"E10"	High limit	Reset the high limit by manually pushing up on the red reset button; if the high limit does not reset, the high limit must be replaced per the High Limt Temperature Control Section
"E15"	Drain Switch	Close the drain, using the drain valve handle; if display still shows "E-15", check the drain microswitch per the Drain Switch Section

SECTION 2. MAINTENANCE

2-1. INTRODUCTION

This section provides checkout and replacement procedures, for various parts of the fryer. Before replacing any parts, refer to the Troubleshooting Section to aid you in finding the cause of the malfunction.

2-2. MAINTENANCE HINTS

1. A multimeter will help you to check electric components.
2. When the manual refers to the circuit being closed, the multimeter should read zero unless otherwise noted.
3. When the manual refers to circuit being open, multimeter should read infinity.



Do not move fryer with hot shortening in the frypot or filter pan. Severe burns can result from splashing hot shortening.

4. Remove weights from frame to easily access rear of fryer.

2-3. PREVENTIVE MAINTENANCE

To ensure a long life of fryers and their components, regular maintenance should be performed. Refer to the chart below.

Procedure	Frequency
Filtering of shortening	See KFC's Standards Library
Changing of shortening	See KFC's Standards Library
Changing the filter envelope	See KFC's Standards Library
Cleaning deadweight assy.	Daily -See Deadweight Valve Section
Cleaning the frypot	See KFC's Standards Library
Reversing lid gasket	Each 90 Days -see Reversing Lid Gasket Section
Lubricate rear lid rollers	Annually -See Lubricating Lid Rollers Section
Cleaning safety relief valve	Annually -See Removal/Cleaning of Safety Relief Valve Section
Inspecting lift Cables	Annually

**2-4. HIGH TEMPERATURE
LIMIT CONTROL**



This high temperature control is a safety, manual reset control, which senses the temperature of the shortening. If the shortening temperature exceeds 425°F (218°C), this switch opens and shuts off the heat to the frypot. When the temperature of the shortening drops to a safe operation limit, manually reset by pressing the red reset button. The red reset button is located under the control panel, in the front of the fryer, to the right of the drain. Once reset, the frypot starts heating.

Checkout

Before replacing a high temperature limit control, check to see that its circuit is closed.

NOTICE

The shortening temperature must be below 380°F (193°C) to accurately perform this check.

1. Remove electrical power supplied to the fryer.



To avoid electrical shock or property damage, move the power switch to OFF and disconnect main circuit breaker, or unplug cord at wall receptacle.

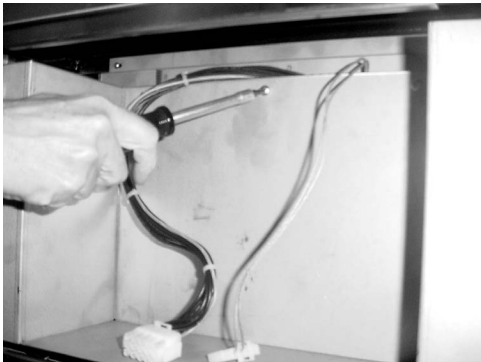

2. Remove the control panel.

3. Remove the inner heat shield.

4. Remove two nuts securing the high limit bracket to unit, and pull the bracket from the unit.

5. Remove two screws securing the high limit to the bracket, and remove the high limit from the bracket.

6. Remove the two electrical wires from the high temperature limit control.

7. Manually reset control, then check for continuity between the two terminals after resetting the control. If circuit is open, replace control, then continue with this procedure. (If the circuit is closed, high limit is not defective. Reconnect the two electrical wires.)



**2-4. HIGH TEMPERATURE
LIMIT CONTROL
(Continued)**



To avoid electrical shock or property damage, move the power switch to OFF and disconnect main circuit breaker, or unplug cord at wall receptacle.

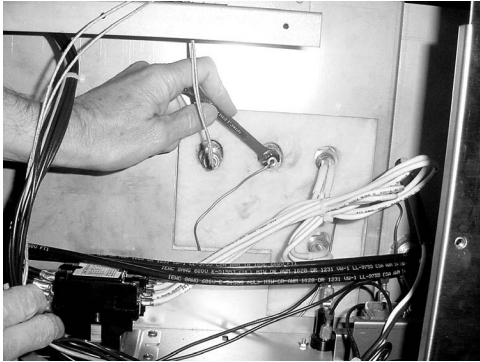

Replacement

1. If the tube is broken or cracked, the control will open, shutting off electrical power. The control cannot be reset.
2. Drain shortening from the frypot and discard. A substance in the tube could contaminate the shortening.
3. Remove control panel.
4. Loosen small inside screw nut on capillary tube.
5. Remove capillary bulb from bulb holder inside the frypot.
6. Straighten the capillary tube.
7. Remove larger outside nut that threads into pot wall, and remove defective control from control panel area.
8. Insert new control and replace screws.
9. Uncoil capillary line, starting at capillary tube, and insert through frypot wall.

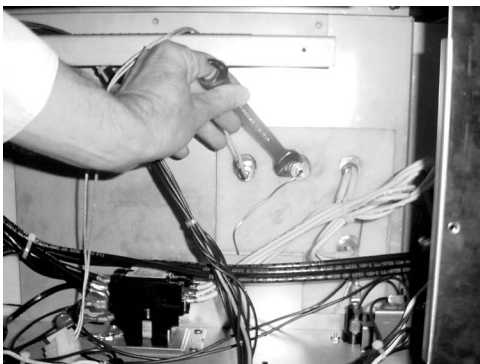

To avoid electrical shock or other injury, run capillary line under and away from all electrical power wires and terminals. The tube must never be in such a position where it could accidentally touch the electrical power terminals.

10. Carefully bend the capillary tube as shown in photo and place into bulb brackets.

**2-4. HIGH TEMPERATURE
LIMIT CONTROL
(Continued)**

11. Pull excess capillary line from pot and tighten nut into frypot wall.

CAUTION

Be sure capillary bulb of high limit is positioned so it does not interfere with carrier or get damaged when cleaning frypot.

12. With excess capillary line pulled out, tighten smaller nut.
13. Replace inner and front panels.
14. Refill with shortening.

2-5. FUSE HOLDERS



There are two fuse holders on each model of the electric fryers. To check or change fuse, unscrew black fuse holder cap.



To avoid electrical shock or property damage, move the power switch to OFF and disconnect main circuit breaker, or unplug cord at wall receptacle.

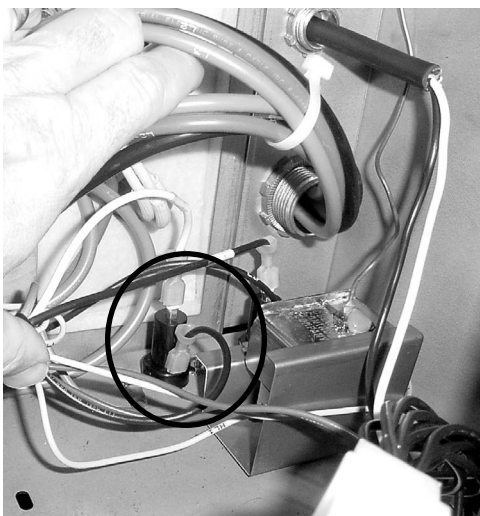

Checking Procedure for Fuse Holders

CONTROL PANEL FUSES 3 Phase

Remove the control panel and pull the wires from the fuse holder terminals. Using a multimeter or continuity light, check across the terminals. The circuit should be closed. If not, replace the fuse (HP# EF02-007) or fuse holder (HP# EF02-006).

2-6. POWER/PUMP SWITCH

The POWER/PUMP switch is a three way rocker switch with a center OFF position. With switch in the POWER position, the fryer operates. With switch in PUMP position, the filter pump operates, but the unit will not heat.



To avoid electrical shock or property damage, move the power switch to OFF and disconnect main circuit breaker, or unplug cord at wall receptacle.

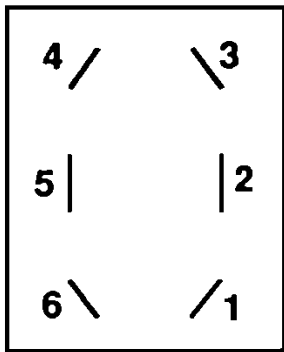

Checkout

1. Remove control panel.
2. Label and remove wires from the switch.
3. OFF position-should be open circuit anywhere on switch.
4. Power position. Check from: #5 to #6 closed circuit
#1 to #2 closed circuit
5. Pump position. Check from: #4 to #5 closed circuit
#3 to #2 closed circuit

NOTICE

Check across the jumpers on the wires of POWER/PUMP switch. These jumpers have resistors and capacitors which may be faulty.

Replacement

1. With control panel removed, and wires off of the switch, push in on tabs on the switch to remove from the panel.
2. Replace with new switch, and reconnect wires to switch following the wiring diagram.
3. Replace the control panel.

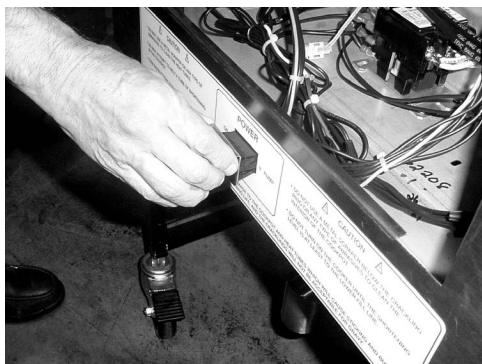

2-7. TEMPERATURE PROBE REPLACEMENT

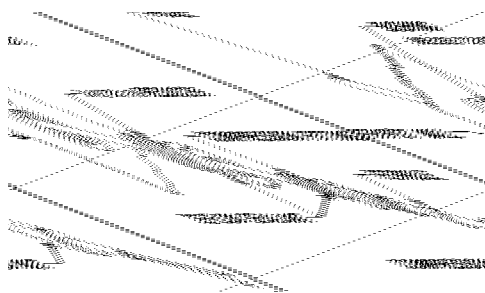
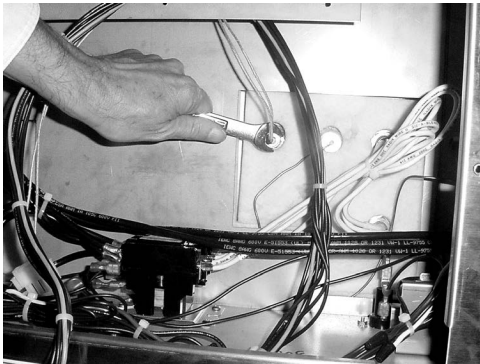

Figure 2-1

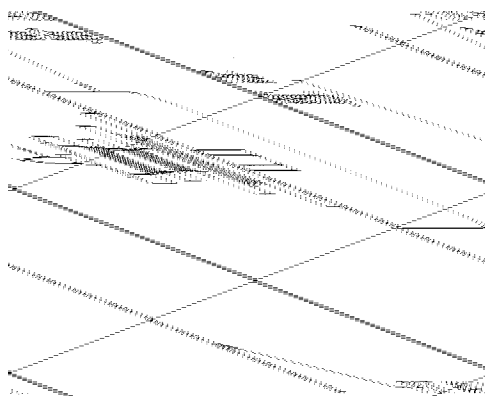

Figure 2-2

Temp. F	Temp. C	Resistance Ohms	Temp. F	Temp. C	Resistance Ohms
50	10.00	1039.02	250	121.11	1464.79
60	15.56	1060.65	260	126.67	1485.71
70	21.11	1082.24	270	132.22	1506.58
80	26.67	1103.80	280	137.78	1527.43
90	32.22	1125.32	290	143.33	1548.23
100	37.78	1146.81	300	148.89	1569.00
110	43.33	1168.26	310	154.44	1589.73
120	48.89	1189.67	320	160.00	1610.43
130	54.44	1211.05	325	162.78	1620.77
140	60.00	1232.39	330	165.56	1631.09
150	65.56	1253.70	340	171.11	1651.72
160	71.11	1274.97	350	176.67	1672.31
170	76.67	1296.20	360	182.22	1692.86
180	82.22	1317.40	365	185.00	1703.13
185	85.00	1327.99	370	187.78	1713.38
190	87.78	1338.57	380	193.33	1733.87
200	93.33	1359.69	390	198.89	1754.31
210	98.89	1380.79	400	204.44	1774.72
212	100.00	1385.00	410	210.00	1795.10
220	104.44	1401.84	420	215.56	1815.44
230	110.00	1422.86	430	221.11	1835.74
240	115.56	1443.85	440	226.67	1856.01

The temperature probe relays actual shortening temperature to the control. If it becomes disabled, “E06” will show in the display. Also, if temperature is out of calibration more than 10°F, or 10°C, the temperature probe should be replaced. An Ohm check can be performed also. See chart at end of this section.

1. Remove electrical power supplied to the fryer.



To avoid electrical shock or property damage, move the power switch to OFF and disconnect main circuit breaker, or unplug cord at wall receptacle.

2. Drain the shortening from the frypot.
3. Remove the control panel.
4. Using a 1/2” wrench, remove the nut on compression fitting.
5. Remove the temperature probe from the frypot.
6. Place nut and new ferrule on new temperature probe and insert temperature probe into compression fitting until it extends one-half (1/2) inch (1.3 cm) into frypot. Use temperature probe gauge provided in temperature probe kit, to ensure proper placement in frypot. See Figures 2-1 & 2-2.
7. Tighten hand tight and then a half turn with wrench.



Excess force will damage temperature probe.

8. Connect new temperature probe to PC board and replace control panel.
9. Replace shortening.
10. Turn power on and check out fryer.

2-8. COMPLETE CONTROL PANEL-HENNY PENNY



Should the control panel become inoperative, follow these instructions for replacing the board.

1. Remove electrical power supplied to the fryer.



To avoid electrical shock or property damage, move the power switch to OFF and disconnect main circuit breaker, or unplug cord at wall receptacle.

2. Remove the two screws securing the control panel and lift panel up and out
3. Unplug the connectors going to the control board.
4. Install a new control panel.

2-9. PRESSURE REGULATION

The Henny Penny Fryer uses pressure as one of the components of the cooking process. Once the lid is sealed to the frypot, and the solenoid valve closes, a deadweight valve maintains the correct pressure in the frypot.

The lid has minimal and limited maintenance and repair procedures, which are addressed in the following sections.

The following is a routine maintenance schedule for the Lid:

Every 90 days

- Clean and reverse the lid gasket

Yearly Inspection

- Check Lid Gasket for splits and tears-replace if necessary
- Check Pressure Pads for wear-rotate if necessary
- Check Cam Slide Guides-replace if worn or broken
- Check Lid Rollers-replace if cracked or damaged

2-10. TILTING THE LID UPRIGHT



The Lid Assembly is easily tilted up for cleaning or servicing.

1. Raise the lid and remove racks and carrier.
2. Grasping the lid handle, lift the front of the lid up until it stops in an upright position.



Be sure the metal arm on the left side of the lid is in the vertical position holding lid upright, or severe injuries could result. (See photo at left).

2-11. REVERSING THE LID GASKET

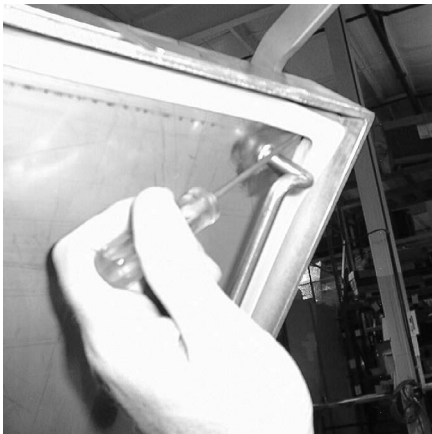

The gray rubber gasket surrounding the inside of the lid is designed to be reversed.

Because of heat expansion and the pressure used for cooking process, gasket is constantly under extreme stress. Reversing the lid gasket will help to assure that the fryer will not lose pressure through leakage.

1. Put the lid in the upright position, as previously described.
2. Using a thin blade screwdriver, pry out the gasket at the corners. Remove the gasket.

NOTICE

Check the gasket for any tears or nicks. If the gasket is damaged it needs to be replaced.



Be sure the metal arm on the left side of the lid is in the vertical position holding lid upright, or severe injuries could result. (See photo in Tilting Lid Upright section)

3. Clean the gasket and gasket seat with hot water.
4. Rotate the gasket with the opposite side facing out.

NOTICE

Install the 4 corners of the lid gasket. Smooth gasket into place, working from the corners towards the middle of each side.

2-12. LID COUNTERWEIGHT CABLES



The Lid Counterweight in the back of the fryer balances the weight of the lid system to allow easier opening and closing of the lid. The weight has two cables attached to it, and weighs about 150 lbs. (67.5 Kg).

1. Using a 3/8" socket, remove the nuts securing rear shroud of the fryer and remove the shroud.
2. Using Phillips-head screwdriver, remove screws securing the top cap and remove cap.
3. Raise the lid.
4. Unscrew broken cable from the weight assembly and the bracket attached to the fryer, and remove broken cable.
5. Screw a 5/16" nut on each end of the new cable.
6. Using a wrench, screw new cable into the weight assembly until tight.
7. Using a 1/2" wrench, tighten nut (already threaded on the cable) against weight assembly, securing the cable into the weight assembly.
8. Pull cable over pulley and down behind weight assembly.
9. Insert cable into the hole in the bracket and screw a 5/16" nut onto end of cable. Tighten cable, by screwing the cable through this nut until the weight assembly becomes level.

NOTICE

The safety cable should now have slack in it with the weight assembly level.

10. Tighten nut against the top of the bracket, securing the cable.
11. Replace the top cap and rear shroud. The repair is now complete.

2-13. PRESSURE PAD

The pressure pads are plastic strips that the lid cam presses against to seal the lid.



1. Raise the lid.
2. Remove the 4 screws securing the lid cover and remove cover.



3. Push the lid cam back, off of the pressure pads.



4. Using an Allen wrench, remove the large bolt securing the pad.



5. Using a Phillips head screw driver, remove the small screw securing the pad and remove the broken pad.

NOTICE

If the pressure pad is worn, but not broken, it can be reversed 180 degrees, and the other end of the pad used.

6. Install new pad in reverse order.

2-14. LID ADJUSTMENT

If steam leaks out from around the lid gasket, the pressure pads could be worn or broken. If the pressure pad is worn, but not broken, it can be reversed 180 degrees, and the other end of the pad used. See Pressure Pad Section.

If steam leaks, check for:

- Pressure pad wear
- Cracked or worn gasket
- Gasket installed improperly
- Fryer operating above 12 psi (827 mbar)



Fryer should be operating at 12 psi, or serious burns could result.

2-15. SOLENOID VALVE

This is an electro-mechanical device that causes pressure to be held in the frypot. The solenoid valve closes at the beginning of the Cook Cycle and opens automatically at the end of the Cook Cycle. If this valve should become dirty, or the Teflon seat nicked, pressure will not build up. The electric fryer uses a 208/240 volt 60 hertz coil (50 hertz internationally).



To avoid electrical shock or property damage, move the power switch to OFF and disconnect main circuit breaker, or unplug cord at wall receptacle.

Coil Check Procedure

Remove the solenoid wires from the wire nuts which are found behind the control panel. Check across wires.

	RESULTS
208/240 Volt, 60 Hertz	150 Ohms
208/240 Volt, 50 Hertz	230 Ohms

Replacement

1. Remove the right side panel.
2. Remove the “tru-arc” retaining clip on top of coil housing.
3. Remove the cover.
4. If only the coil is to be replaced, disconnect two coil wires at wire nuts in the coil housing. Remove coil, insert new coil, and connect wires at wire nuts. Assemble in reverse order of disassembly.



NOTICE

The wires may be connected in any order.



2-15. SOLENOID VALVE
(Continued)



5. If the core-disc assembly is sticking due to buildup of shortening, breadings, and food particles, proceed with the following steps:
 - a. Unscrew the solenoid bonnet assembly from solenoid valve body.
 - b. Remove solenoid bonnet assembly and bonnet gasket.
 - c. Remove the core-disc assembly, core spring retainer, and the core spring.
 - d. Wash all these parts in hot water.

NOTICE

If Teflon seals need to be replaced, proceed to Step 6; otherwise, assemble in reverse order of disassembly. Assemble valve core and blade with smooth side and rounded edge of blade toward the disc spring guide.

6. Repair kit, Part No. 17120, is available if any of the seals must be replaced. If one seal is defective, replace all seals.

NOTICE

Solenoid body must be removed from the fryer for replacement of seals. Continue on to step 7.

7. Loosen wires on the strain relief and pull the wires through the relief.
8. With the bonnet assembly and core-disc assembly removed, disconnect the two nut fittings. One connects the solenoid valve to the deadweight, the other is attached to the condensation tank.
9. Remove the elbows from the solenoid valve.
10. Remove the two adapter screws which attach the pipe adapter to the solenoid valve body.
11. Remove the disc spring, guide, and Teflon seat.
12. Clean the valve body.

2-15. SOLENOID VALVE
(Continued)

13. Wet “O” ring around seat with water and insert O-ring assembly (flat side first) in valve through “IN” side of body. Use an eraser end of pencil and press in the Teflon seal until it snaps into place. Be careful not to mar or nick the seat.

NOTICE

The smallest nick can cause a pressure leak. Replace all O-ring seals that are in the parts kit and reassemble the valve.

14. If the complete valve is to be replaced, follow steps 1, 2, 3, 4, 5, 7, 8 and 9 in this section.

2-16. DEADWEIGHT VALVE

⚠ DANGER
BURN RISK

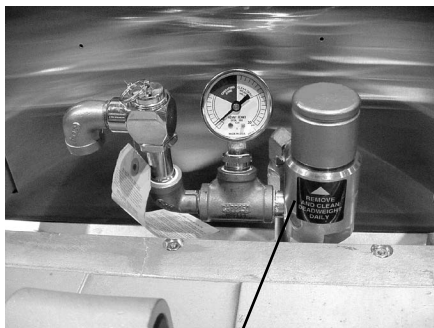

Deadweight valve

DO NOT ATTEMPT TO REMOVE DEADWEIGHT CAP WHILE FRYER IS OPERATING. SEVERE BURNS OR OTHER INJURIES WILL RESULT.

The operating valves are located behind the lid. The valve, left of the pressure gauge, is a 14 1/2 lb. (999 mbar) safety relief valve, and the one on the right is the deadweight valve.

Valves are working properly, when the pointer on the gauge is in the “OPERATING ZONE” (green area). The gauge pointer should not normally exceed the operating zone. If the pressure builds to 14 1/2 lbs.(999 mbar), the safety relief valve will open to release steam pressure from inside frypot.

2-16. DEADWEIGHT VALVE
(Continued)



DO NOT PULL THE RING ON THE SAFETY RELIEF VALVE. HOT STEAM WILL BE RELEASED AND SEVERE BURNS WILL RESULT.

1. At the end of each day's usage of the fryer, the deadweight valve must be cleaned. The fryer must be OFF and pressure released. Open the lid and then remove the deadweight valve cap and deadweight.

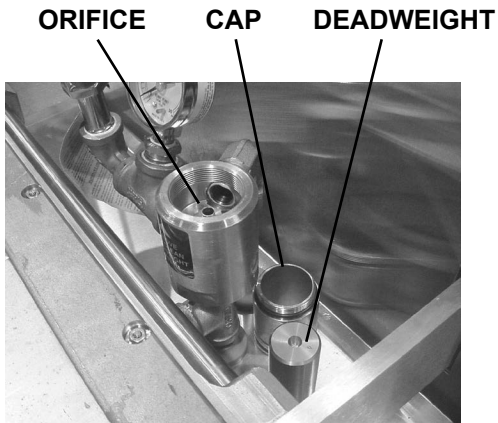

Failure to clean the deadweight assembly daily could result in the fryer building too much pressure. Severe injuries and burns could result.

2. Wipe both the cap and weight with a soft cloth. Make certain to thoroughly clean inside cap, the weight seat, and around deadweight orifice.
3. Dry the parts and replace immediately to prevent damage or loss.

2-17. REMOVAL & CLEANING
OF SAFETY RELIEF
VALVE

The safety relief valve should be cleaned once a year.

SAFETY RELIEF VALVE

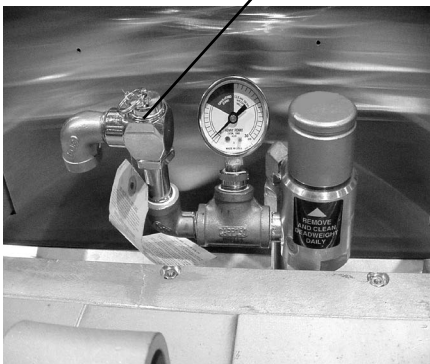

DO NOT ATTEMPT TO REMOVE SAFETY VALVE WHILE FRYER IS OPERATING, OR SEVERE BURNS OR OTHER INJURIES WILL RESULT.

1. Remove pressure gauge.

**2-17. REMOVAL & CLEANING
OF SAFETY RELIEF
VALVE (Continued)**

2. Use a wrench to loosen the valve from the pipe tee, turn counterclockwise to remove.
3. Clean the inside of the pipe tee with hot water.

NOTICE

Turn the safety relief valve towards the rear of the fryer when reinstalling safety relief valve.

4. Immerse the safety relief valve in a soapy water solution for 24 hours. Use a 1 to 1 dilution rate. The valve cannot be disassembled. It is factory preset to open at 14 1/2 pounds of pressure. If it does not open or close, it must be replaced.



DO NOT DISASSEMBLE OR MODIFY THIS VALVE. TAMPERING WITH THIS VALVE COULD CAUSE SERIOUS INJURIES AND WILL VOID AGENCY APPROVALS AND APPLIANCE WARRANTY.

2-18. PRESSURE GAUGE

Calibration Steps

The pressure gauge can be recalibrated should it be out of adjustment.

1. Remove the rim and glass.
2. If the indication hand shows a pressure or vacuum reading when it should stand at "0", turn the recalibrator screw in the same direction in which the indicating hand is to be moved until the hand stands a proper "0" position.
3. Replace the rim and glass.

Cleaning Steps

1. Remove the gauge and check inside the pipe fittings from deadweight body. Make certain fittings are clean and open.
2. Clean and reinstall the gauge.

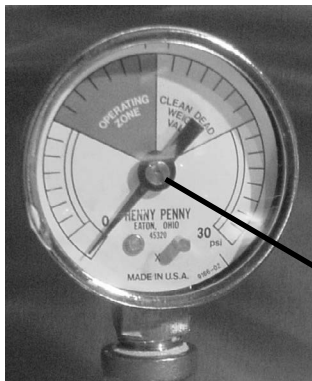

**Adjusting
Screw**

2-19. CONTACTORS

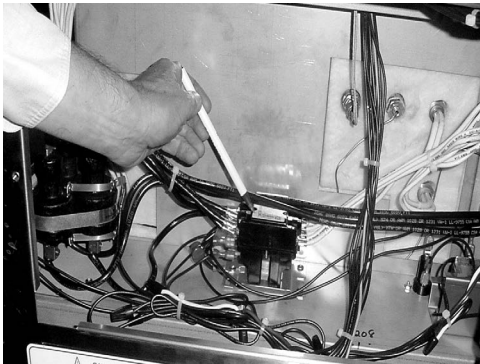

Primary

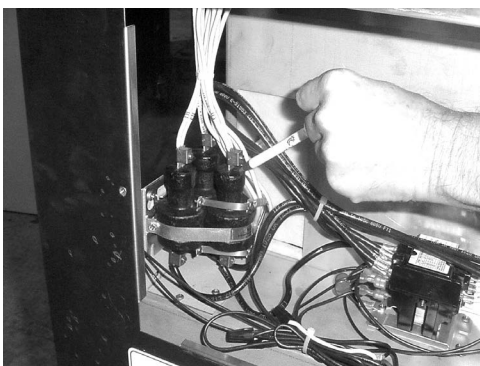

Heat

The electric fryer requires two switching contactors: a primary and a heat contactor. The primary contactor energizes (contacts close) any time the POWER/PUMP switch is in the POWER position, and the temperature of the shortening is below 420° F (215° C). The high limit cuts power at the primary contactor if the temperature of the shortening is above 420° F (215° C). The primary contactor supplies power to one side of the heat contactor.

The heat contactor is controlled by the computer controller. When the controller calls for heat, the heat contactor applies power to one side of the heating elements. When the heat contactor and primary contactor are energized (contacts closed) the electric heating elements heat the shortening.

NOTICE

The photo shows a mercury heat contactor, but CE countries will have an electromechanical heat contactor.

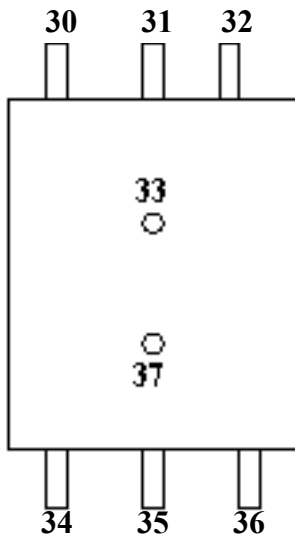

Primary Contactor

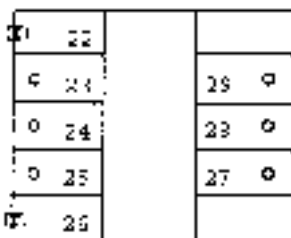

Checkout

1. Remove electrical power supplied to the fryer.



To avoid electrical shock or property damage, move the power switch to OFF and disconnect main circuit breaker, or unplug cord at wall receptacle.

2. Remove the control panel.
3. Label and remove wires from contactors and perform a check on both contactors as follows:

<u>Test Points</u>	<u>Results</u>
From 23 to 29	open circuit
From 24 to 28	open circuit
From 25 to 27	open circuit
From 30 to 34	open circuit
From 31 to 35	open circuit
From 32 to 36	open circuit
From 33 to 37	ohm reading 1700
From 22 to 26	ohm reading 415

2-19. CONTACTORS
(Continued)



To avoid electrical shock, make connections before applying power, take reading, and remove power before removing meter leads. The following checks are performed with the wall circuit breaker closed and the main power switch in the ON position.

4. With power reapplied and in a heat-up mode, check the power going to both contactor coils. This is to be sure power is going to the contactors.

If no voltage is found going into the primary contactor coil, check wiring, high limit, and drain switch. If no voltage at heat contactor coil, check wiring and connections at PC board.

Replacement

If either contactor proves defective, replace as follows:



To avoid electrical shock or property damage, move the power switch to OFF and disconnect main circuit breaker, or unplug cord at wall receptacle.

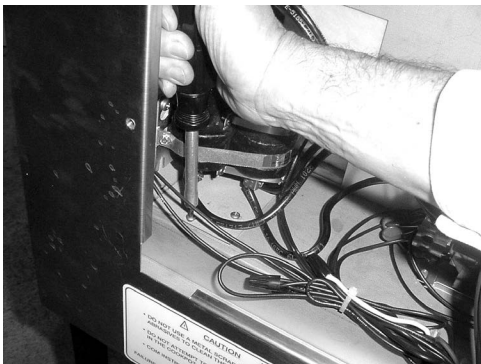

1. Label and remove only those wires directly connected to the contactor being replaced.
- Hint: Removing the left side panel may be helpful in replacing the heat contactor.
2. Remove the mounting screws on the base plate of the primary contactor and remove contactor. Proceed to step 5.
 3. Remove the screws securing the mercury contactor bracket to the mounting plate and remove bracket and contactor.
 4. Remove the screws securing the contactor to the bracket and remove contactor from bracket.
 5. Install new contactor in reverse order.
 6. Install control panel and reconnect power to the fryer and test for proper operation.

2-20. HEATING ELEMENTS

The electric model fryer uses 2 heating elements.

NOTICE

Heating elements are available in 208, 220/240, 380 and 415 volts. Check the data plate, on the shroud behind the lid, to determine the correct voltage elements.

1. Remove the electrical power supplied to the unit.



To avoid electrical shock or property damage, move the power switch to OFF and disconnect main circuit breaker, or unplug cord at wall receptacle.

2. Remove the control panel.

3. Remove both side panels.

4. Remove upper screws and loosen the lower screws, to the front control shroud, and hinge it down. (See photo at left)

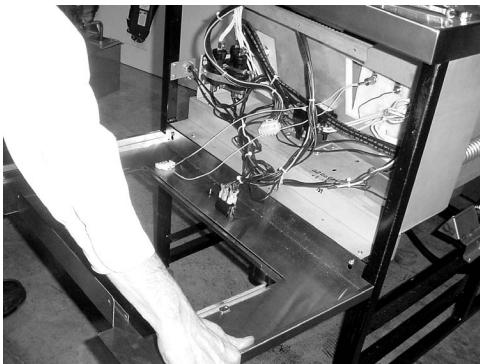

To avoid electrical shock, make connections before applying power, take reading, and remove power before removing meter leads. The following checks are performed with the wall circuit breaker closed and the main power switch in the ON position.

5. Perform an amp check on one heating element at a time with the wires connected to the contactors. The 2 heaters actually have 3 small heating elements on the inside of the outer plate. It is important to check between the correct wires to obtain the accurate amp reading. The wires are labeled for your convenience.

Wires	Power	Voltage	Amperage
L1-L3	8500W	208V	47.8
L3-L2	8500W	208V	47.9
L2-L1	8500W	208V	48.0
L1-L2	8500W	240V	39.4
L3-L2	8500W	240V	40.1
L2-L1	8500W	240V	39.9

2-20. HEATING ELEMENTS
(Continued)

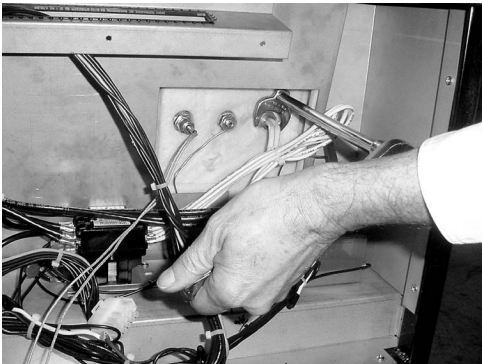

Replacement

1. Drain the shortening.
2. Remove the high limit bulb holder from the heating element inside the frypot.
3. Disconnect the heating element wires from the contactors. Label each so it can be replaced in the same position on the new element.
4. Remove the heat contactor, as described in Contactors Section, to access the left side element nuts.
5. Loosen the screws on the element spreaders.
6. Slide element spreaders to the center of the heating element.
7. Using a 7/8" crow's foot, remove the brass nuts and washers which secure the ends of the elements through the frypot wall.
8. Remove the heating elements from the frypot as a group by lifting the far end, and sliding them up and out towards the rear of the frypot.

NOTICE

Always install new rubber O-rings (2) when installing heating elements.

9. Install new heating elements with new rubber O-rings mounted on terminal ends, and spreaders loosely mounted in the center of the stacked elements.
10. Replace the heating elements, terminal end first at approximately 45° angle, slipping the terminal ends through the front wall of the frypot.

2-20. HEATING ELEMENTS
(Continued)

10. Replace the brass nuts and washers on the heating element terminals. Tighten the brass nuts to 30 foot lbs of torque.
11. Replace heat contactor.
12. Move the element spreaders from the center of the element, into a position which will spread each element apart evenly on all four sides, and tighten.
13. Replace the high limit bulb holder on the top element, and position the bulb between the top and second element midway from side to side, and tighten screw which holds the bulb in place.
14. Reconnect the wires to the appropriate terminal as labeled when they were removed.
15. Replace the front control shroud and control panel.
16. Replace side panels.
17. Connect the power cord to the wall receptacle or close wall circuit breaker.

CAUTION

Heating elements should never be energized without shortening in the frypot, or damage to elements could result.

2-21. DRAIN MICROSWITCH

Upon pulling out on the drain handle, the microswitch should be activated and the unit will not heat, but when the handle is pushed back, the unit should operate properly. The bracket on the microswitch is slotted so it can be adjusted backward or forward.

1. Remove electrical power supplied to the unit.



To avoid electrical shock or property damage, move the power switch to OFF and disconnect main circuit breaker, or unplug cord at wall receptacle.



2. The following check should be made to determine if the drain switch is defective.
 - a. Remove bracket from the unit.
 - b. Remove wires from the switch.
 - c. Check for continuity across the two outside terminals on the drain switch. If circuit is open, the Drain Switch is bad. The circuit should only be opened by pressing on the actuator of the Drain Switch.

1/8" (4 mm) Gap

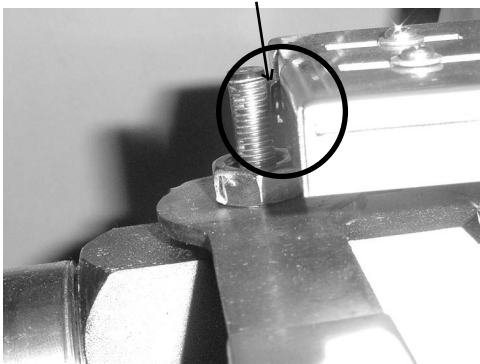

3. To replace switch, remove switch from the bracket, and install switch in reverse order.
4. Test to see if drain valve handle actuates the switch. The gap between the drain switch and the shaft should be no more than 1/8" (3 mm).

HINT: Listen for audible click of switch while pulling drain valve handle.

**2-22. DRAIN VALVE
AND EXTENSION**



The drain valve opens when the drain valve handle is pulled out and drains the shortening out of the pot.

Replacement

1. Using a 3/8" socket, remove the nuts securing the drain switch bracket, and pull the bracket from the studs.
2. Remove the nut securing the drain handle and pull the handle from the drain valve.
3. Using a large adjustable wrench, unscrew the drain valve and extension from the unit.
4. Replace the drain valve and extension.
5. Replace the drain switch bracket.
6. Adjust the microswitch to be no more than 1/8" (3 mm) from the shaft of the drain valve.

HINT: Listen for audible click of switch while pulling drain valve handle.

2-23. NYLATRON STRIPS REPLACEMENT



1. Raise the lid and remove the retention ring from one end of the lid pin.
2. Slide the lid pin from unit.
3. Lift the lid from unit.



The lid weighs 80 lbs (36 kg). Take care when lifting lid to prevent personal injury.



4. Using a 3/8" socket, remove the nuts securing the rear shroud and remove shroud.
5. Using a Phillip's-head screwdriver, remove the screws securing the top cap and remove top cap.
6. Remove the bolts securing the nylatron strips to the weight assembly and remove strips from weight assembly.



7. Using a Phillip's-head screwdriver, remove the screws securing the front shroud.

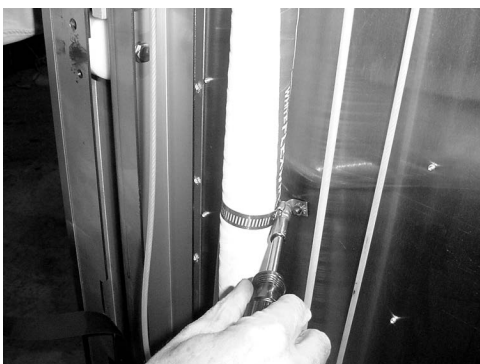

8. Unfasten the exhaust hose from the hose clamp.

2-23. NYLATRON STRIPS
REPLACEMENT
(Continued)



9. Lift the front shroud up and out, over the arm of the lid.

10. Thread the new nylatron strip through the track in the front shroud.

11. Lining up the holes in the strips, fit the front shroud back over the lid arms.

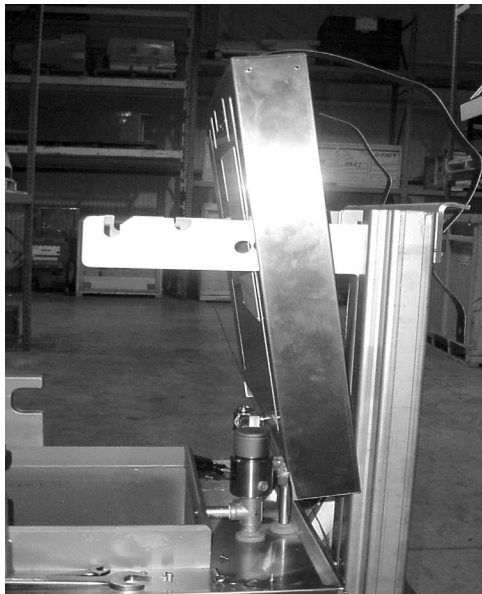

12. Secure the strips to the weight assembly.

13. Replace back shroud, top cap, and lid, and replacement is complete.

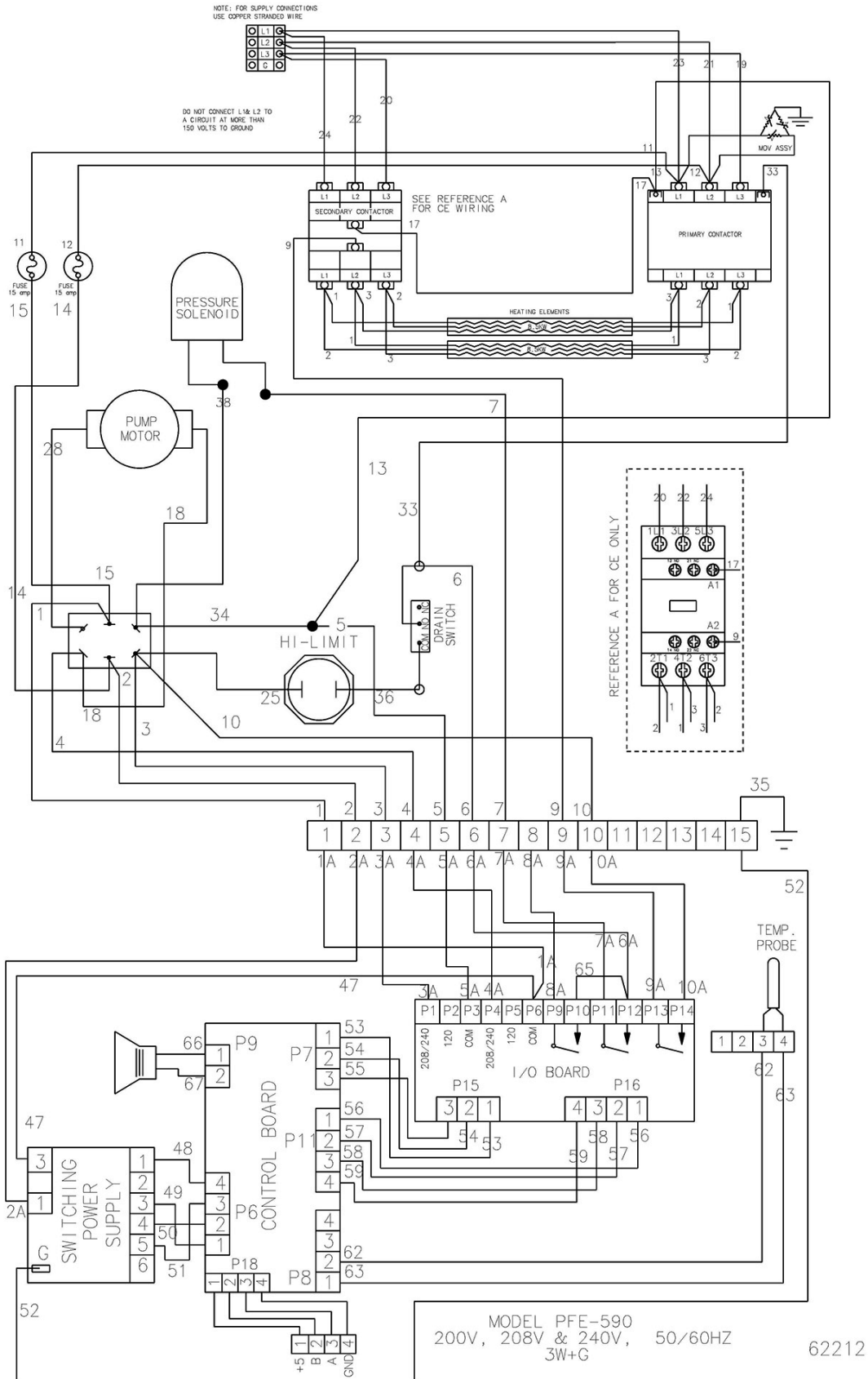

SN: AC0608030 & below

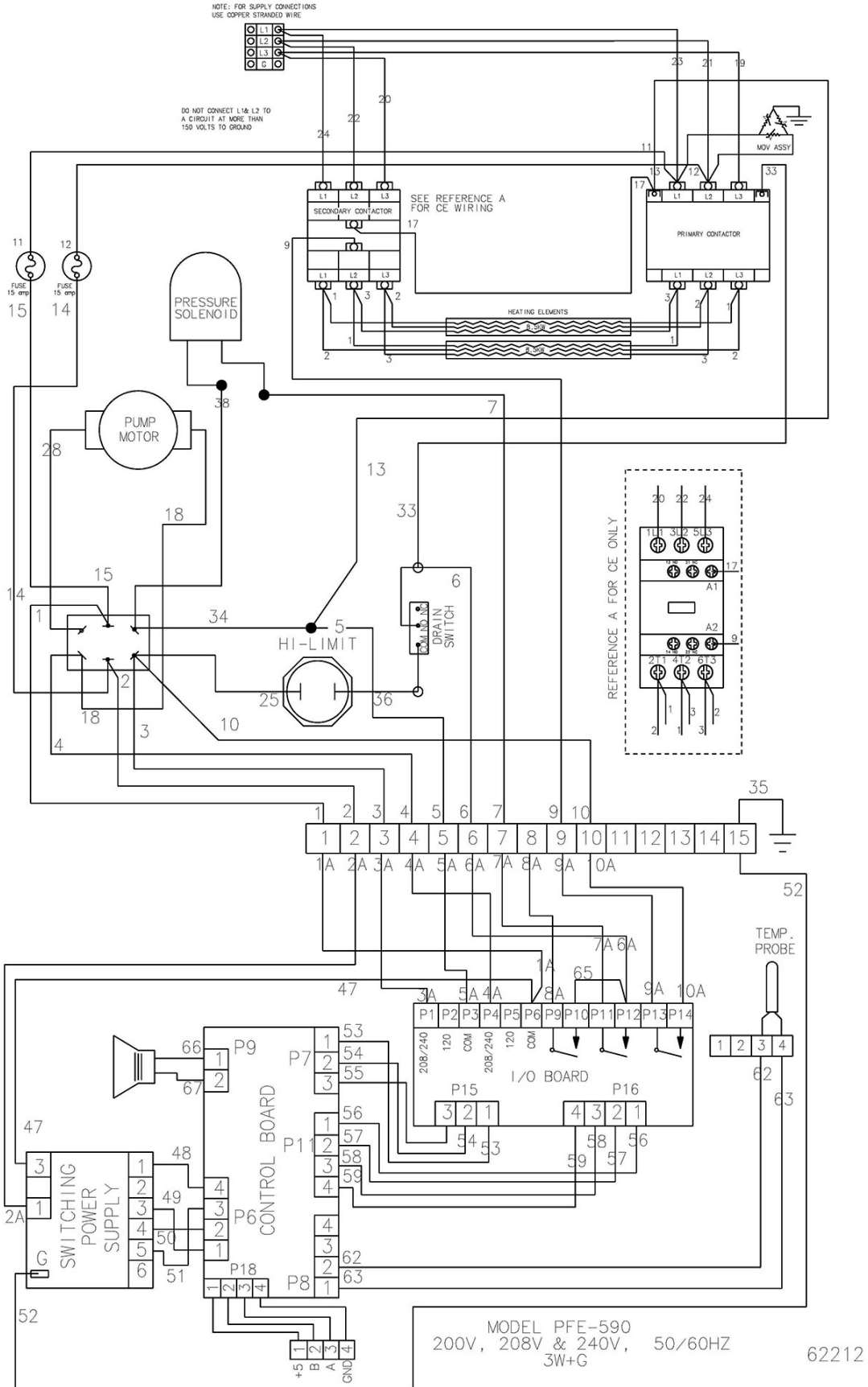

SN: AC0608031 & above

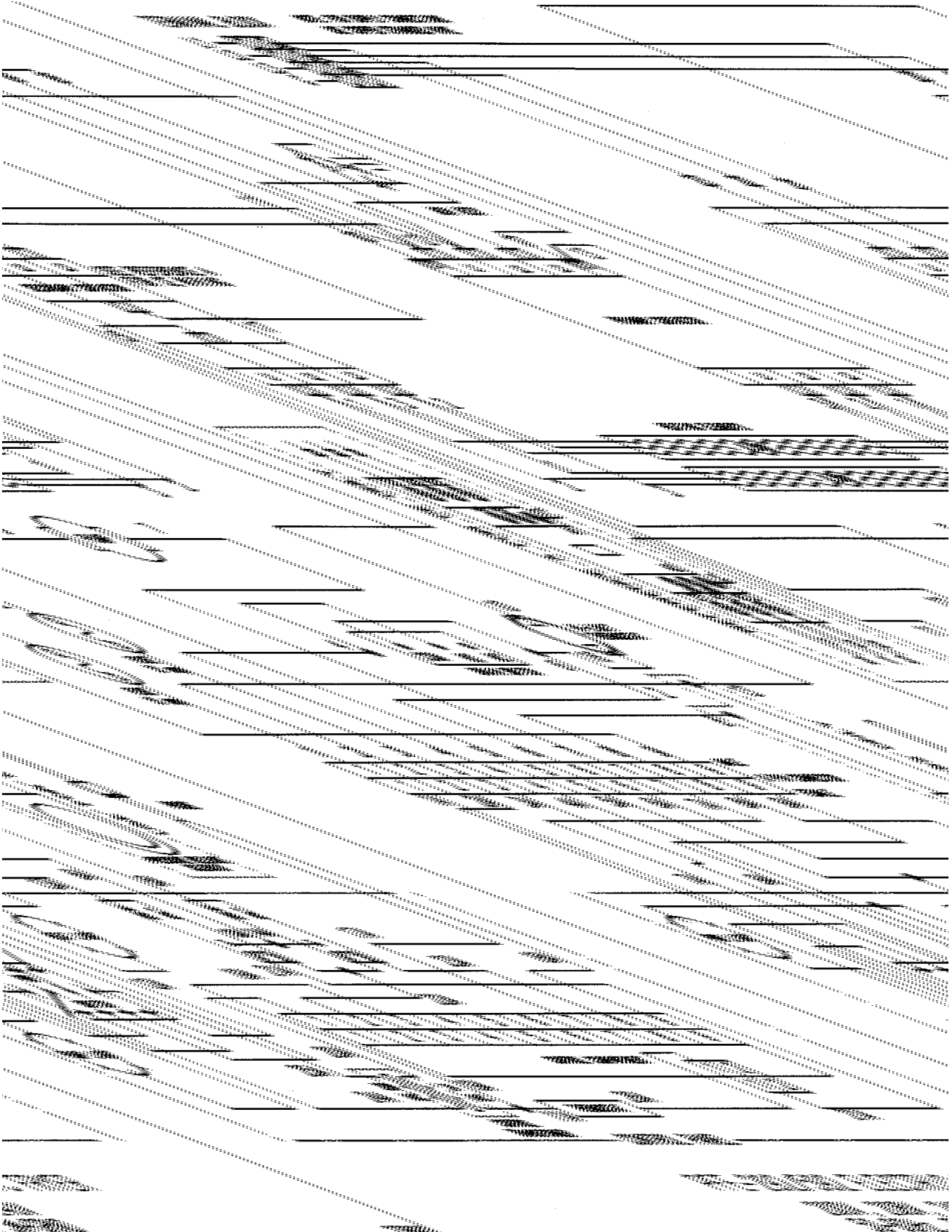

SN: AC0608030 & below

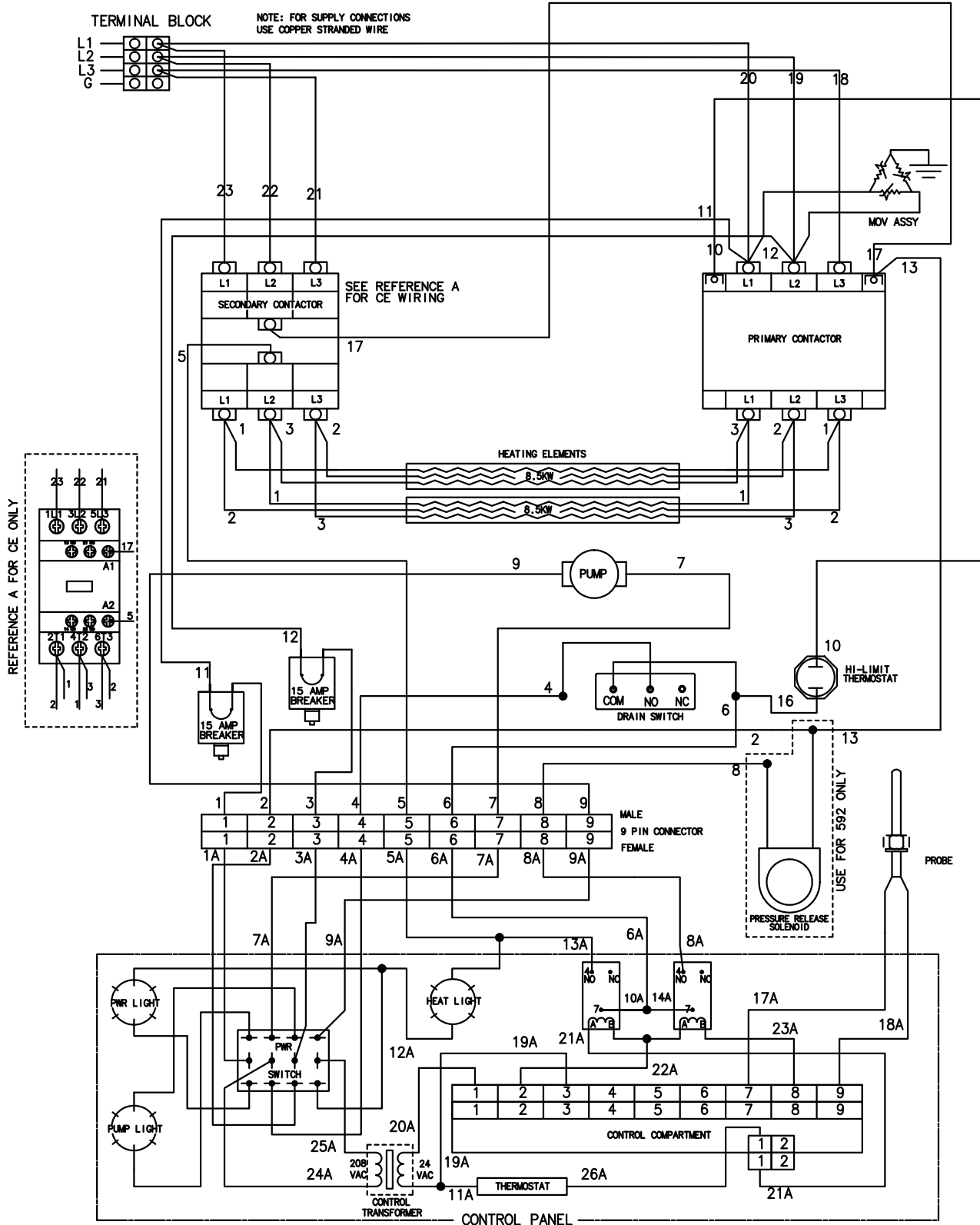

PFE-292/592 ELECTRIC FRYER

200V, 208V, 240V
50-60Hz, 3W+GRND

23890

SN: AC0608031 & above

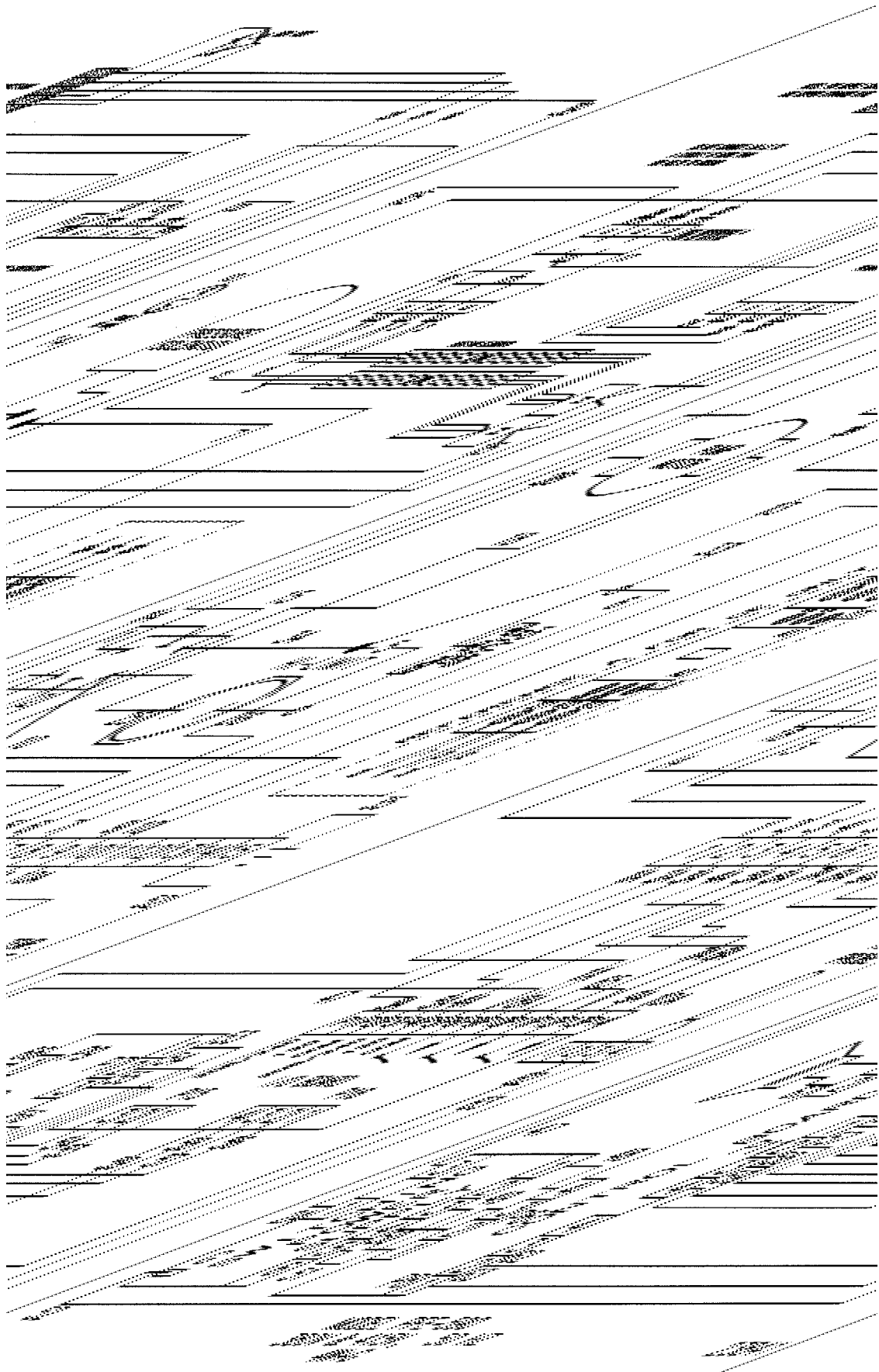

SN: AC0608030 & below

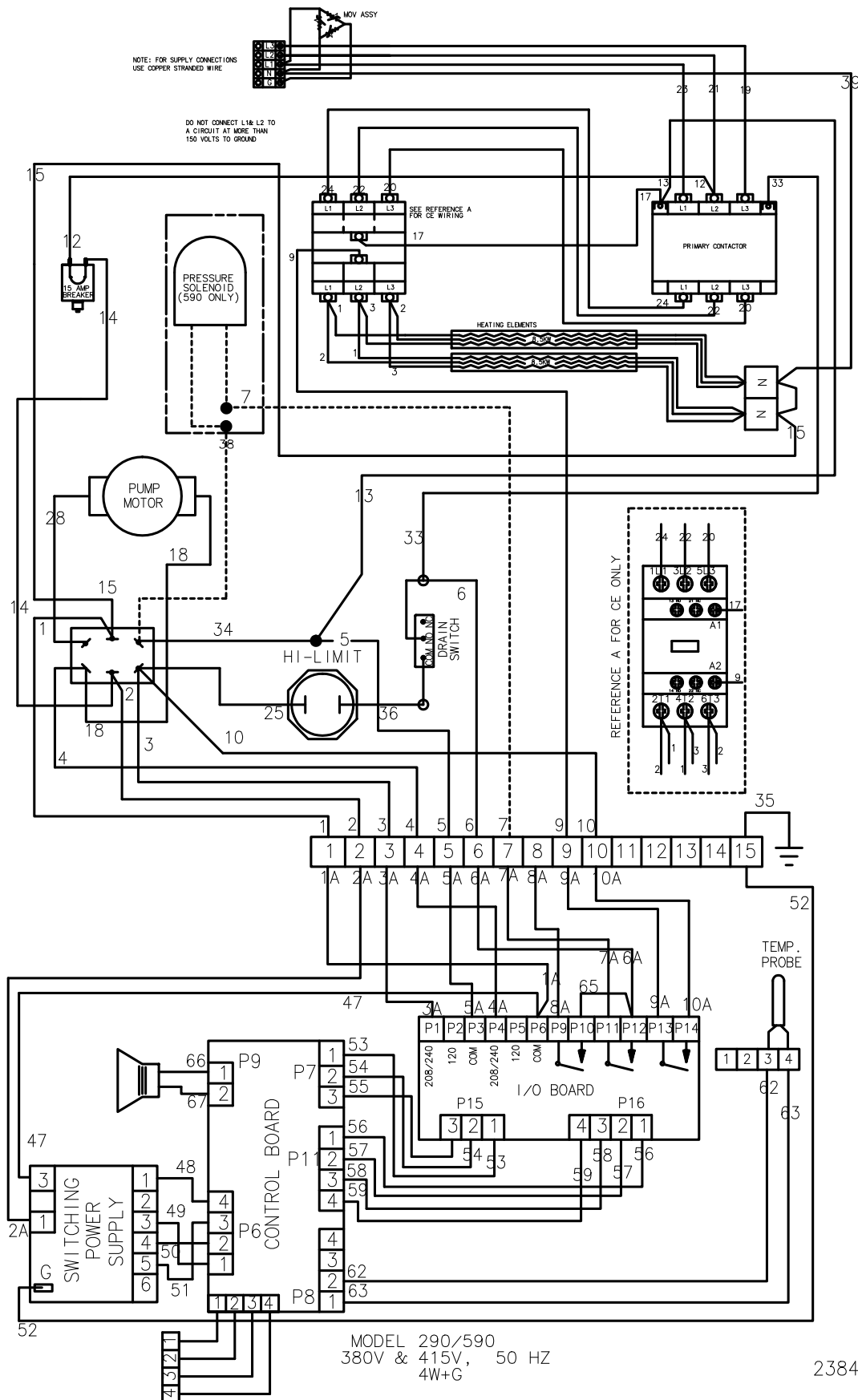

SN: AC0608031 & above

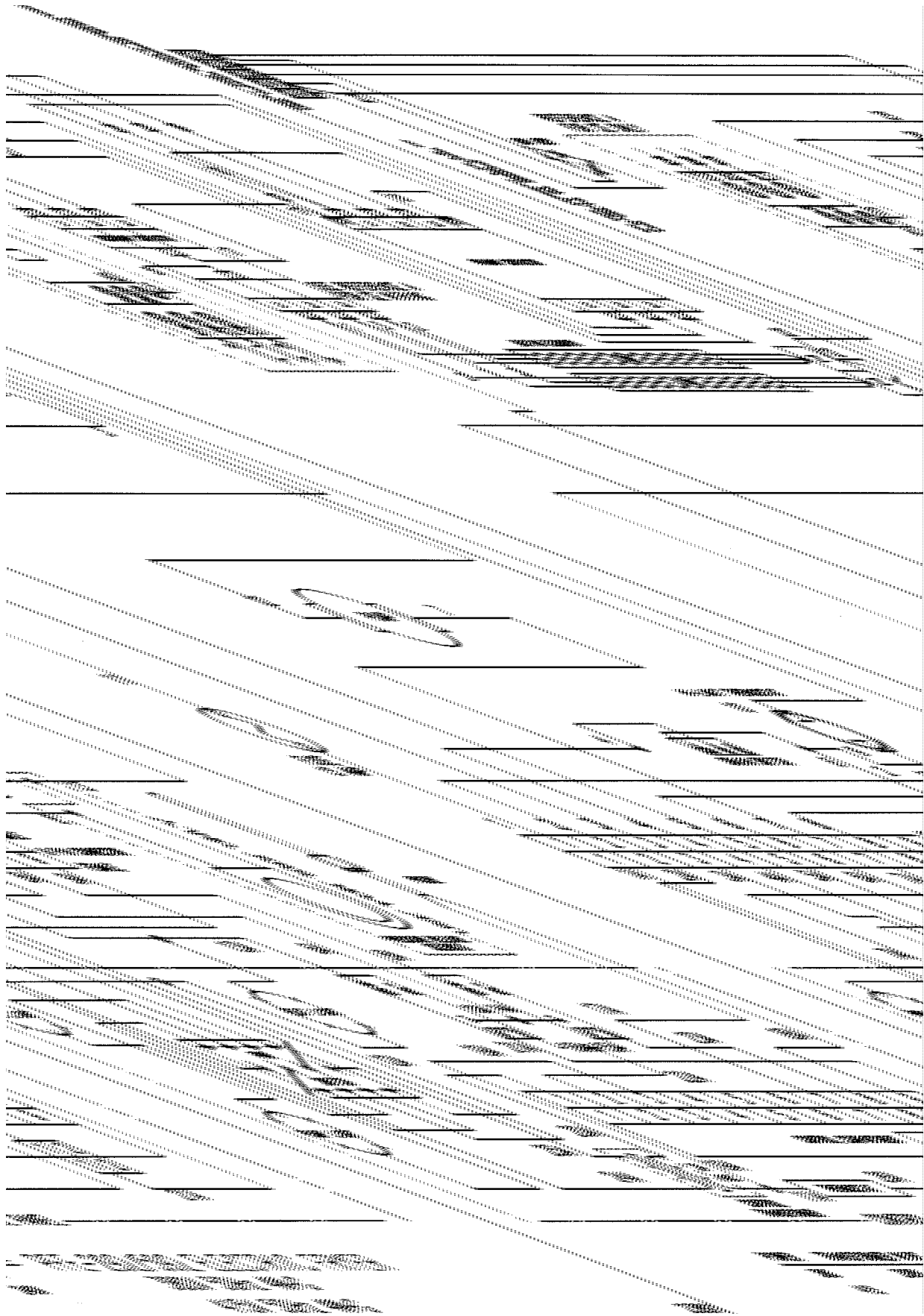

SN: AC0608030 & below

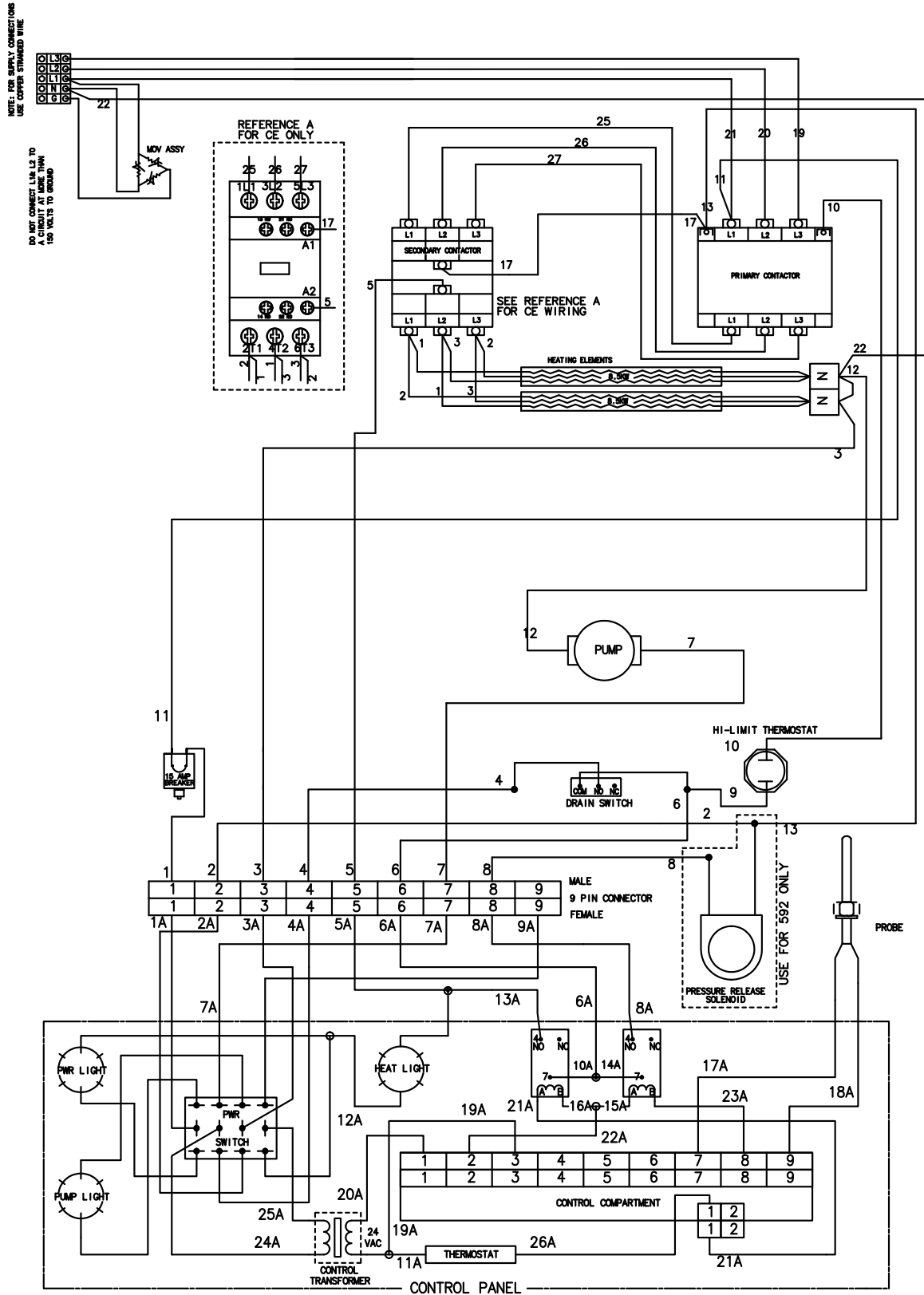

POWER	TRANSFORMER WIRE
380	240V
415	240V

PFE-292/592 ELECTRIC FRYER
380V 50Hz 4W+G
415V 50Hz 4W+G

SN: AC0608031 & above

23891

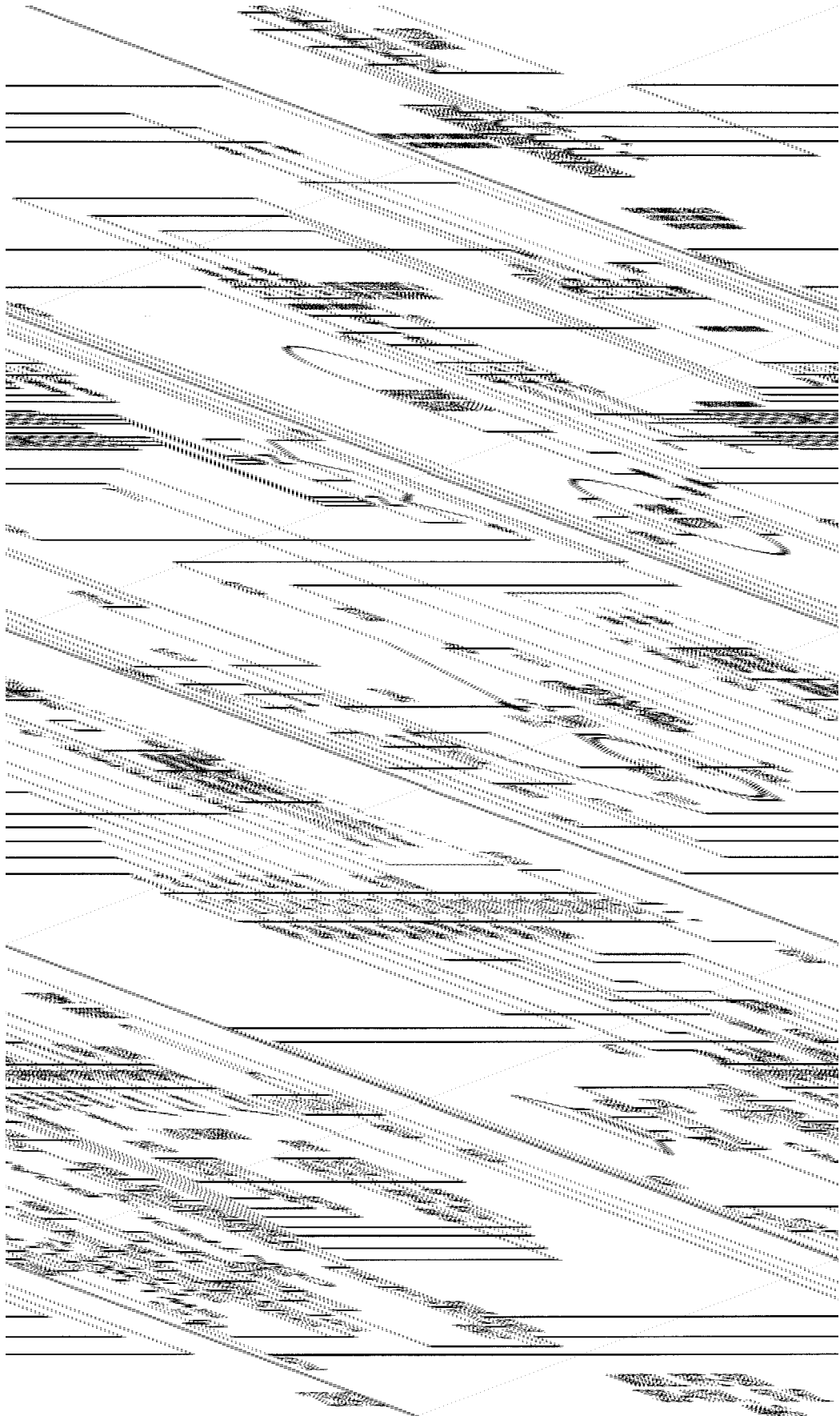

SN: AC0608030 & below

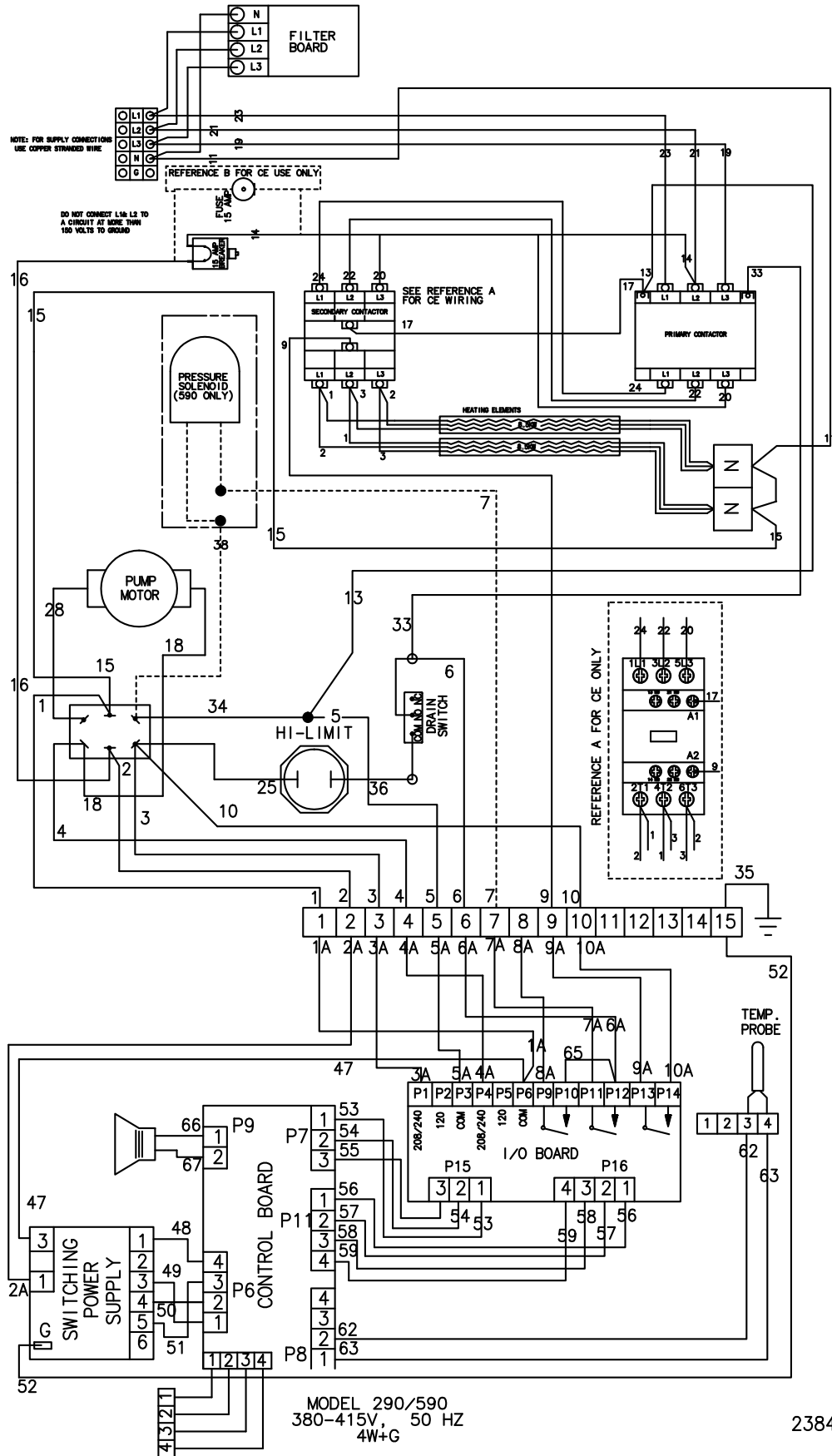

23842

SN: AC0608031 to 10-4-07

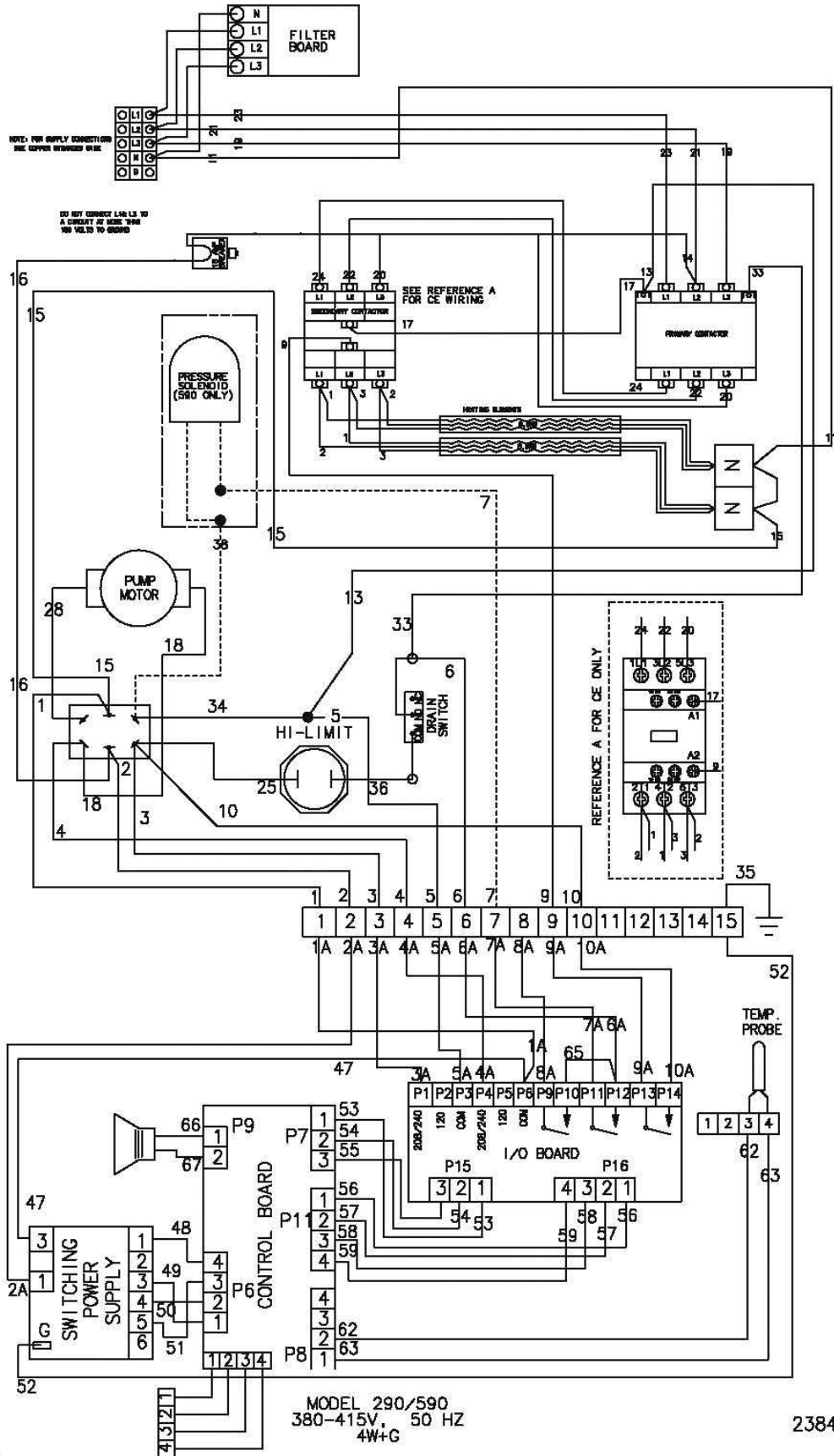

10-4-07 & After

NOTE: FOR SUPPLY CONNECTIONS
USE COPPER STRANDED WIRE

DO NOT CONNECT LINE L2 TO
GROUND AT A POINT MORE THAN
150 VOLTS TO GROUND

PFE-292/592 ELECTRIC FRYER
400V 50Hz 4N+G

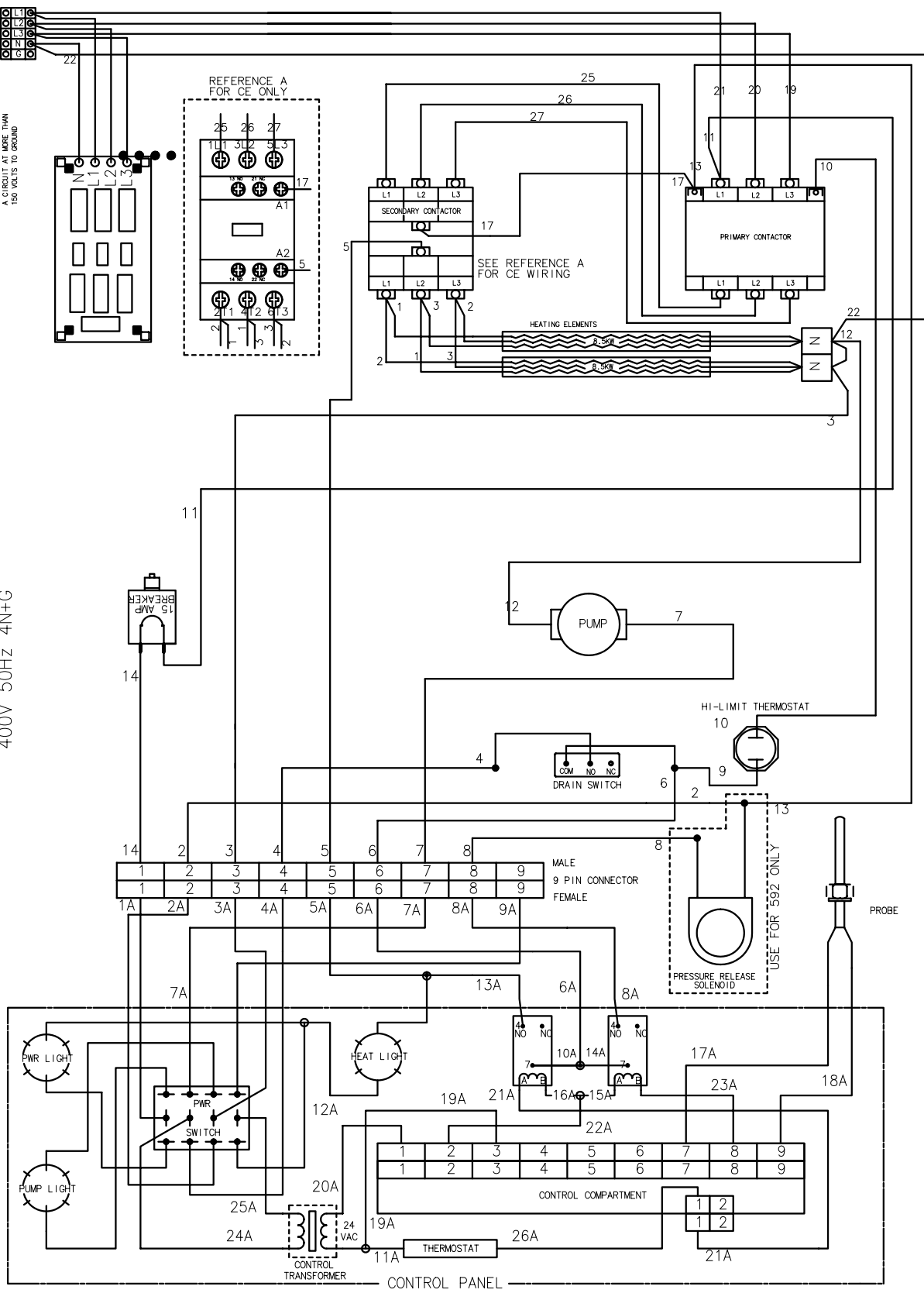

USE 240V TAP
ON TRANSFORMER

23894

10-4-07 & After

SECTION 3. PARTS INFORMATION

3-1. INTRODUCTION

This section lists the replaceable parts of the Henny Penny Model 590 fryer.

3-2. GENUINE PARTS

Use only genuine Henny Penny parts in your fryer. Using a part of lesser quality or substitute design may result in damage to the unit or personal injury.

3-3. WHEN ORDERING PARTS

Once the parts that you want to order have been found in the parts list, write down the following information:

Item Number	2	
Part Number	<u>16738</u>	Example:
Description	<u>High Limit</u>	

From the data plate, list the following information:

Product Number	<u>01100</u>	
Serial Number	<u>0001</u>	Example:
Voltage	<u>208</u>	

3-4. PRICES

Your distributor has a price parts list and will be glad to inform you of the cost of your parts order.

3-5. DELIVERY

Commonly replaced items are stocked by your distributor and will be sent out when your order is received. Other parts will be ordered, by your distributor, from Henny Penny Corporation. Normally, these will be sent to your distributor within three working days.

3-6. WARRANTY

All replacement parts (except lamps and fuses) are warranted for 90 days against manufacturing defects and workmanship. If damage occurs during shipping, notify the carrier at once so that a claim may be properly filed. Refer to warranty in the front of this manual for other rights and limitations.

3-7. RECOMMENDED SPARE PARTS FOR DISTRIBUTORS

Recommended replacement parts, stocked by your distributor, are indicated with √ in the parts lists. Please use care when ordering recommended parts, because all voltages and variations are marked. Distributors should order parts based upon common voltages and equipment sold in their territory.

3-8. INDEX OF PARTS LIST ILLUSTRATIONS

Title	Fig. No.	Page No.
FRAME & COVER ASSEMBLY.....	3-1	3-3
ELEMENT ASSEMBLY	3-2	3-5
COUNTERWEIGHT SYSTEM	3-3	3-6
LID & COVER ASSEMBLY	3-4	3-7
STEAM BOX & HOSE ASSEMBLY	3-5	3-9
DEADWEIGHT & SOLENOID ASSEMBLY	3-6	3-10
SOLENOID VALVE ASSEMBLY	3-7	3-12
FAST READY PARTS.....	3-8	3-14
CONTROL PANEL ASSEMBLY.....	3-9	3-16
BEHIND CONTROL PANEL COMPONENTS	3-10	3-17
FILTER PUMP ASSEMBLY (SN: LG012JC & BELOW)	3-11A	3-18
FILTER PUMP ASSEMBLY (SN: LG013JC & ABOVE).....	3-11B	3-20
DRAIN VALVE & DRAIN SWITCH ASSEMBLIES.....	3-12	3-22
DRAIN PAN & FILTER ASSEMBLY	3-13	3-23
CARRIER, RACKS & JUNCTION BOX ASSY.....	3-14	3-25

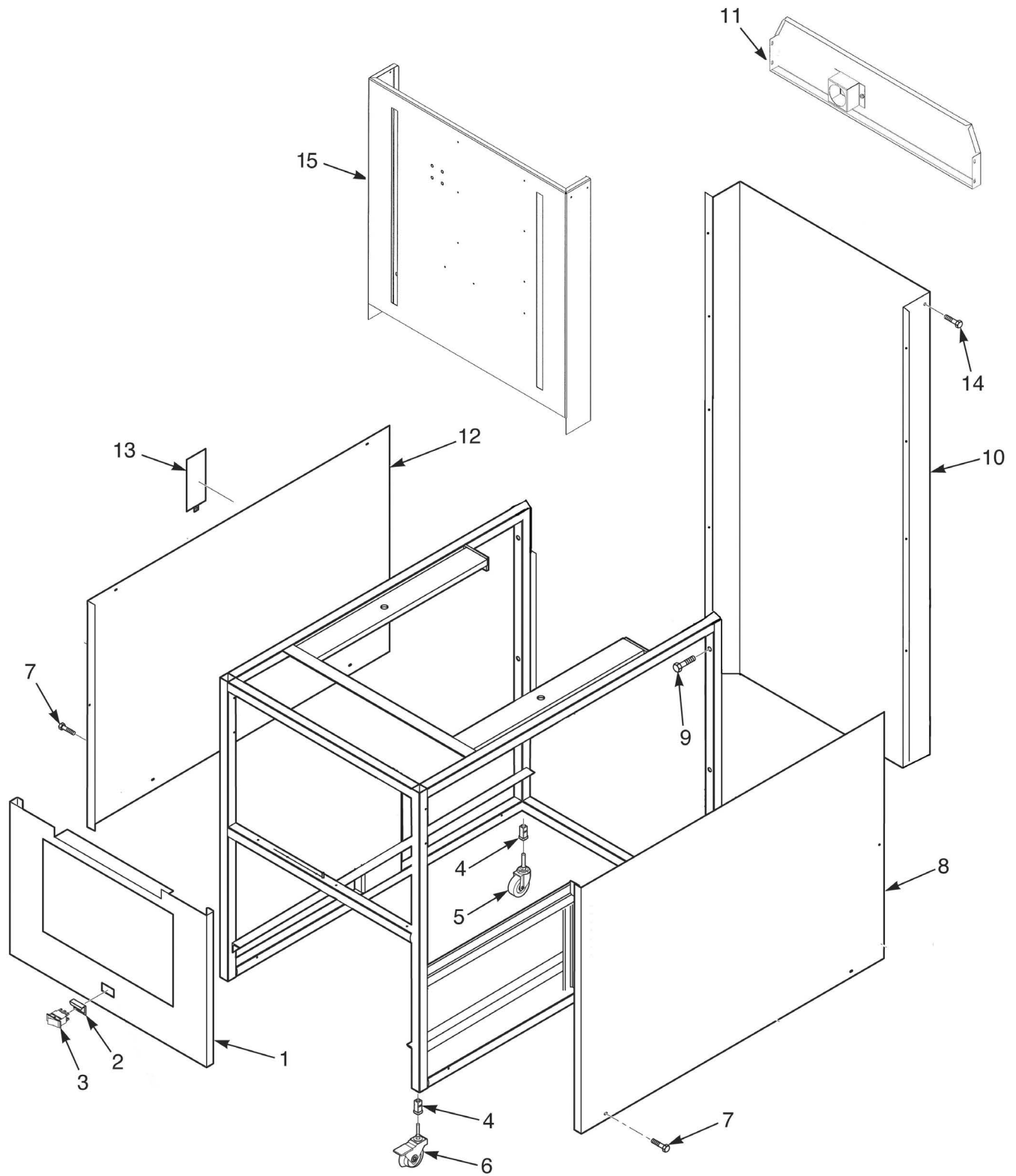

FIGURE 3-1. FRAME & COVER ASSEMBLY

Figure & Item No.	Part No.	Description	Qty.
3-1		FRAME & COVER ASSEMBLY	
1	39796	WELDMENT – CONTROL PANEL FRONT.....	1
2	53669	GUARD – POWER SWITCH.....	1
√ 3	29898	SWITCH – POWER.....	1
4	54225	1” INSERT – LEG MACHINED.....	4
5	35154	CASTER, SWIVEL 4”.....	2
6	37246	CASTER W/BRAKE & SWIVEL LOCK.....	2
7	SC03-005	SCREW - - #8 x 1/2” PH PHD.....	4
8	66934	SIDE PANEL – RIGHT.....	1
9	SC01-215	SCREW - 5/16-18 x 2.5” HEX HD BOLT.....	4
10	37291	REAR SHROUD – ACCESS ASSEMBLY.....	1
11	35726	TOP COVER – REAR SHROUD.....	1
12	66933	SIDE PANEL – LEFT.....	1
12	14457	KIT - SOUND DEADENING.....	1
13	36337	DOOR – ACCESS.....	1
14	SC02-023	SCREW - #8-B x 3/8” PH THD SS.....	5
15	62085	REAR SHROUD.....	1

√ recommended parts

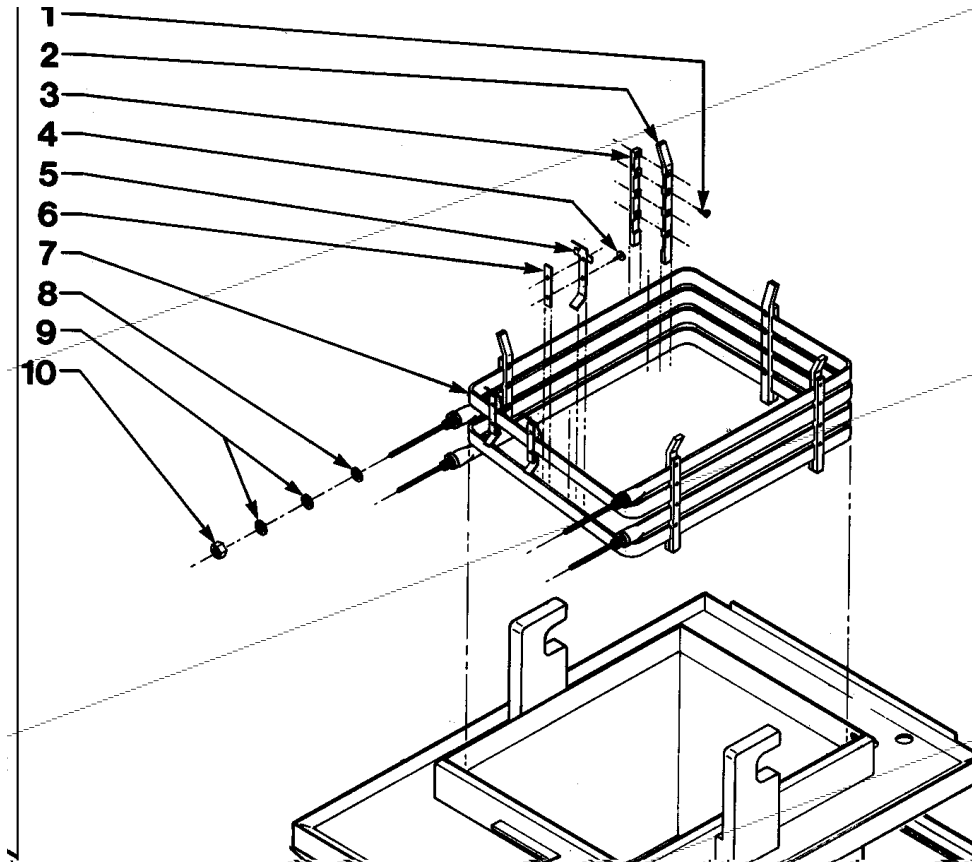

Figure & Item No.	Part No.	Description	Qty.
3-2		ELEMENT ASSEMBLY	
1	SC01-083	SCREW, (#10-32 x 1/2 PH FHD).....	As Required
2	35101	SUPPORT, ELEMENT - LONG.....	5
3	35100	SUPPORT, ELEMENT - SHORT.....	5
4	SC01-074	SCREW, (#10-32 x 1/2 PH THD S).....	As Required
5	35435	BRACKET, HI LIMIT PROBE.....	3
6	35462	BRACKET, HI LIMIT PROBE.....	3
√ 7	35234	HEAT ELEMENT ASSEMBLY, 8.5 KW 208V.....	2
√	35598	HEAT ELEMENT, 8.5 KW 240V.....	2
√	48367	HEAT ELEMENT, 230 V(Int'l Only).....	2
√	36290	HEAT ELEMENT, 220 V(Int'l Only).....	2
8	16855	SEAL, O-RING.....	4
9	WA01-005	WASHER, (5/8 DIA. TYPE A - SERIES N).....	8
10	NS01-017	NUT, (5/8-18 B HEX).....	4

√ recommend. parts

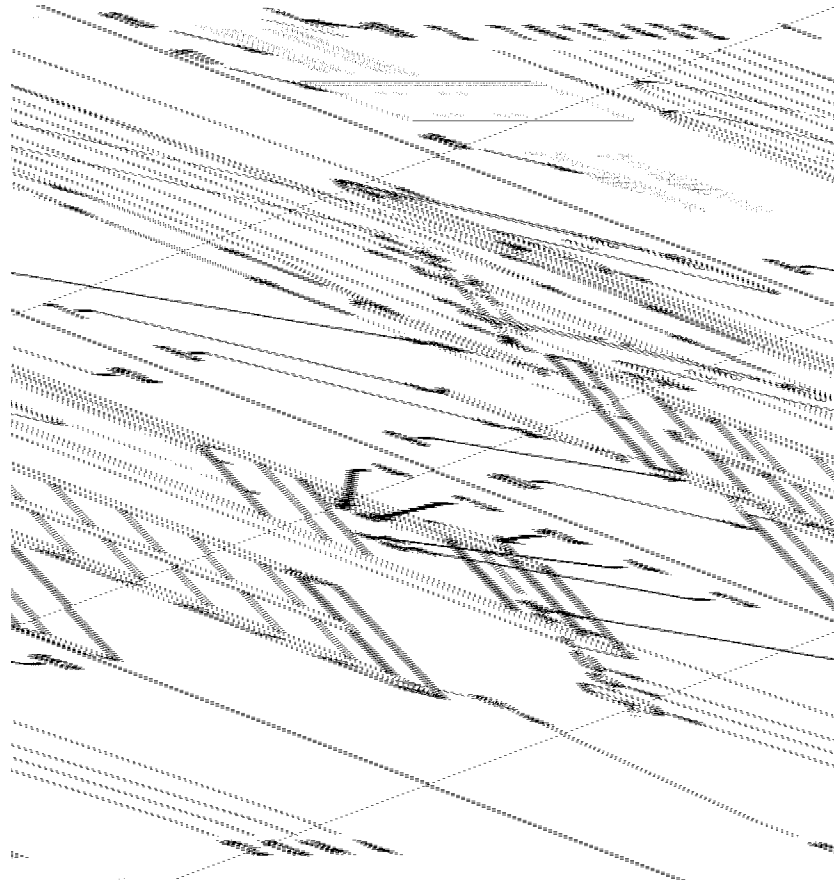
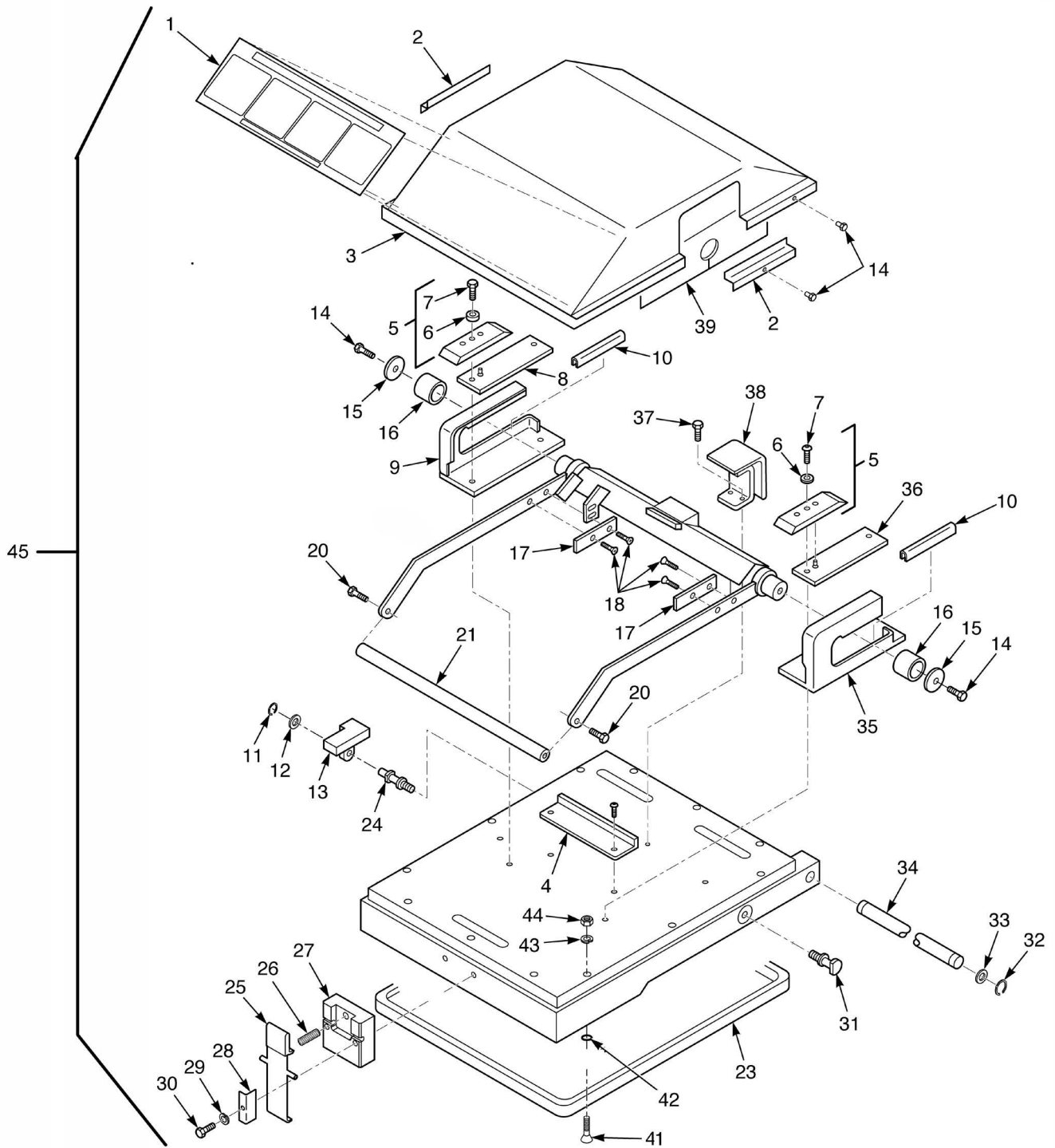

Figure & Item No.	Part No.	Description	Qty.
3-3		COUNTERWEIGHT SYSTEM	
1	35026	ARM, LID SUPPORT	2
√ 2	140225	KIT-CABLE (2 CABLES)	1
3	NS01-025	NUT, HEX 5/16-18 SS	10
4	LW01-010	WASHER, 3/8 SPLIT RING SS.....	10
5	35092	CARRIAGE	1
6	SC01-069	SCREW, 3/8-16 X 1-1/2 HEX HD S2P	8
7	36839	SLIDE.....	2
8	SC01-042	SCREW, 3/8-16 X 1 HEX C	2
9	36625	WELD ASSEMBLY, C/W CARRIAGE	1
10	36627	COUNTERWEIGHT BAR	7
11	36626	SPACER, C/W FRAME.....	2
12	37362	WHEEL, CARRIAGE	4
13	37363	SPACER, CARRIAGE WHEEL.....	4
14	37364	SPINDLE	4
15	SC01-081	SCREW, 3/8-24 X 3/4 HEX HD SS.....	4
16	35962	BRACKET/WHEEL ASSY.....	2
17	36561	BRACE, TOP FRAME.....	1
18	35954	PLATE, SUPPORT PULLEY	4
19	SC01-132	SCREW, CAP, SOC HD, 1/2-20 X 5/8	8

√ recommended parts



3-4. LID & COVER ASSEMBLY

Figure & Item No.	Part No.	Description	Qty.
3-4		LID & COVER ASSEMBLY	
1	35792	LID INSTRUCTION LABEL.....	1
2	35675	FILLER-LID.....	2
3	35243	COVER-MAIN LID.....	1
4	35413	PLATE-TRIP.....	1
√ 5	52627	PRESSURE PAD ASSY.	2
6	49852	BUSHING-PRESSURE PAD.....	2
7	SC01-204	SCREW 1/4-20X1.00 SOCK BUTT.....	2
8	49962	PLATE, SHIM ASSY. (L.H.).....	1
9	49890	PLATE, CAM GUIDE (L.H.).....	1
10	35359	SLIDE (6").....	2
11	RR01-004	RING, RETAINING 1/2".....	1
12	WA01-020	WASHER, LID STOP.....	1
13	51531	CAST, LID STOP.....	1
14	SC01-074	SCREW, #10-32 x 1/2 PH THD SS.....	8
15	35223	WASHER, SPECIAL.....	1
16	35227	ROLLER, LINKAGE SHAFT.....	2
17	35339	GUIDE, HANDLE SIDE.....	2
18	SC01-062	SCREW, #6-32 x 3/8 PH FH.....	4
20	SC01-041	SCREW, 5/16-18 x 1.00 HEX HD C.....	2
21	36285	WELDMENT, HANDLE TAP PLATE.....	1
√ 23	34526	GASKET, LID - SN: AC0712021 & below.....	1
√ 23	66620	GASKET, LID - SN: AC0712022 & above.....	1
24	35945	PIN, LID SUPPORT.....	1
25	52497	LATCH ASSEMBLY, COATED.....	1
26	52498	LATCH SPRING.....	1
27	59169	LATCH BRACKET, LID (MACHINED).....	1
28	51707	LATCH BRACKET, LID.....	2
29	LW02-006	LOCKWASHER, LATCH.....	2
30	SC01-248	SCREW, LATCH, 10-32 x 1.25 PH THD SS.....	2
31	35032	PIN, LID SUPPORT.....	1
32	RR01-010	RING, RET. 3/4 SHAFT SS.....	2
33	36312	WASHER, LID HINGE.....	2
34	51697	PIN, LID HINGE.....	1
35	49895	PLATE, CAM GUIDE (R.H.).....	1
36	49963	PLATE SHIM ASSEMBLY (R.H.).....	1
37	SC01-146	SCREW, 1/4-20 x 3/4 HEX HD SS.....	2
38	52477	LIFT, LID.....	1
√ 39	35465	CAM SLIDE FILLER.....	2
41	SC01-195	SCREW, 8-32 x 1-7/16 PH FHD S.....	12
42	OR01-005	O-RING, 5/16 x 1/16 DIA.....	12
43	LW01-002	LOCKWASHER, SPLIT RING 1/4 S.....	12
44	NS01-008	NUT, 8-32 HEX.....	12
45	79418	ASSY - 590 REBUILT LID.....	1

√ recommended parts/* not shown

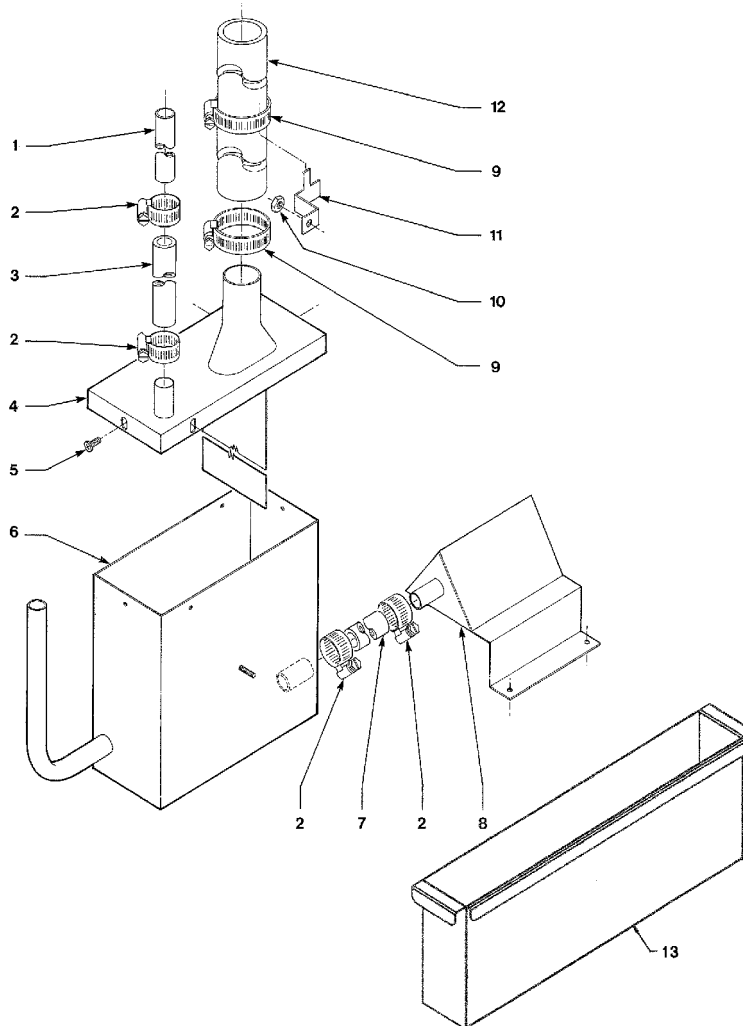
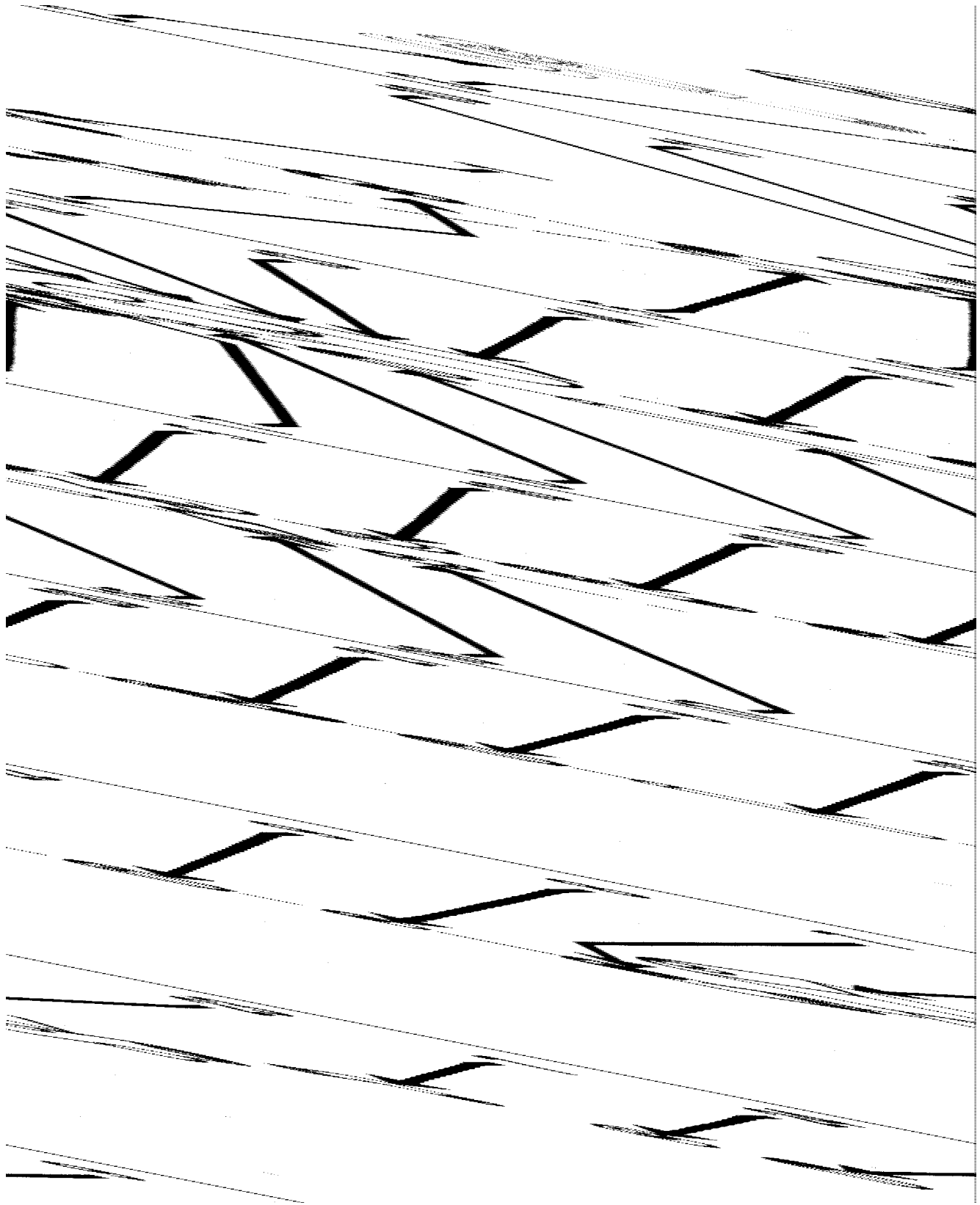

Figure & Item No.	Part No.	Description	Qty.
3-5		STEAM BOX & HOSE ASSY	
1	35686	TUBE, DW TO EXHAUST STACK SS.....	1
2	MS01-297	HOSE CLAMP, SS - .500 – 1.062 DID	4
3	35693	TUBE, EXHAUST CONNECT	1
4	35696	WELDMENT, STEAM EXHAUST BOX LID	1
5	SC02-041	SCREW, #8-18 X 7/16 PH IND XTRNL TRX	4
6	66732	WELDMENT, STEAM EXHAUST BOX.....	1
7	82517	HOSE, CONDENSATE (SN: AC0903045 & ABOVE)	1
7	66723	TUBE, CONDENSATE (SN: IG048JC - AC0903044)	1
7	62211	TUBE, CONDENSATE (SN: IG047JC & BELOW).....	1
8	69263	RESTRICTOR	1
9	MS01-315	HOSE CLAMP, ½ X 1-3/4 SS	2
10	NS01-011	NUT, (#10-32 HEX).....	1
11	36851	BRACKET, HOSE	1
12	21877	TUBING, STEAM EXHAUST.....	4
13	71409	CONDENSATE PAN WELDMENT	1
14*	EF02-118	2 HOLE CONDUIT CLAMP 1" EMT (cond. hose).....	1

* not shown



3-6. DEADWEIGHT & SOLENOID ASSEMBLY

Figure & Item No.	Part No.	Description	Qty.
3-6		DEADWEIGHT & SOLENOID ASSY	
√ 1	16910	PRESSURE GAUGE.....	1
√ 2	59742	RELIEF VALVE ASSY	1
3	FP01-127	ELBOW, STREET, ½ X ½, 90 DEGREE	1
4	FP01-063	REDUCER, ½ NPT M TO ¼ NPT F.....	1
5	FP01-011	PIPE TEE, ½ NPT 304 SS.....	2
6	FP01-028	NIPPLE, CLOSE ½ NPT.....	2
7	17407	CONNECTOR, ½ MALE ELBOW	3
8	16817	FITTING, SLEEVE TEFLON.....	As Required
9	16809	NUT FITTING.....	As Required
10	56307	CAP, DEAD WEIGHT	1
11	16902	SEAL "O" RING	1
12	16903	DEADWEIGHT - 12 PSI	1
12	65449	DEADWEIGHT - 3 PSI	1
12	81343	DEADWEIGHT - 11 PSI.....	1
13	16918	ORIFICE, 12 PSI.....	1
14	16852	BODY, VALVE.....	1
15	35686	TUBE, DW TO EXHAUST STACK.....	1
16	35817	PIPE NIPPLE, ½ X 2 ¼ SS	1
17	16804	UMBRELLA GROMMET	1
18	35200	UMBRELLA GRAMMET	1
19	35474	PIPE NIPPLE, ½ X 2.....	1
20	FP01-066	COUPLING, ½ NPT SS	1
21	16807	FITTING CONNECTOR, MALE	1
22	35147	TUBE, STEAM EXHAUST - UP	1
23	18721	VALVE, SOLENOID 208-240V, 60 Hz	1
23	18724	VALVE, SOLENOID 208-240V, 50 Hz	1
24	16808	FITTING SLEEVE, STEEL.....	1

√ recommended parts

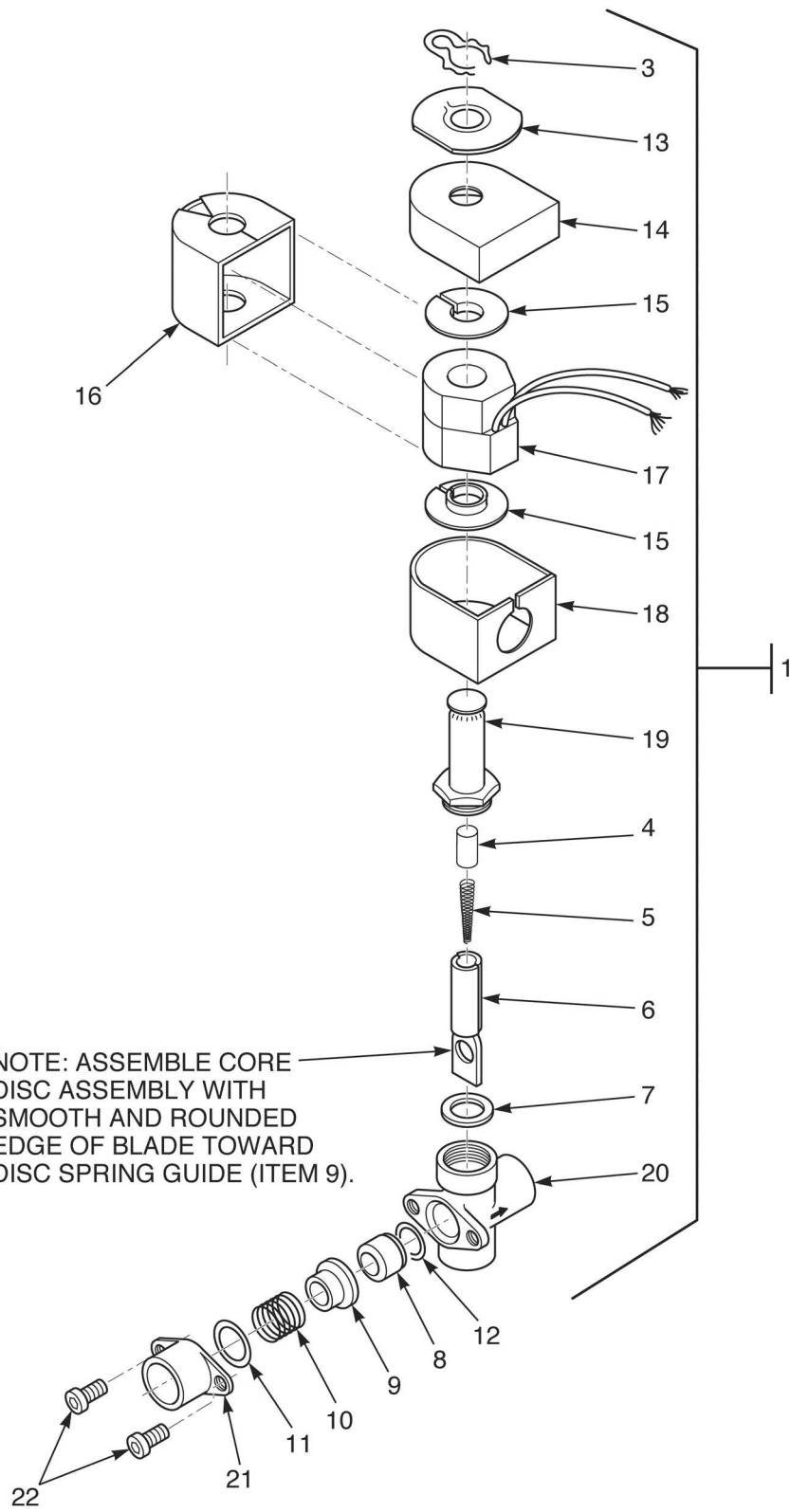

3-7. SOLENOID VALVE ASSEMBLY

Figure & Item No.	Part No.	Description	Qty.
3-7		SOLENOID VALVE ASSEMBLY	
1	18721	VALVE, SOLENOID 208-240V, 60 Hz	1
1	18724	VALVE, SOLENOID 208-240V, 50 Hz	1
√ 2*	17120	KIT, SOLENOID VALVE REPAIR.....	1
3	17101	CLIP, RETAINER.....	1
4	17109	RETAINER, SPRING.....	1
5	17110	SPRING, CORE.....	1
6	17111	CORE, DISC ASSEMBLY	1
7	17112	GASKET, BONNET	1
8	17114	SEAT, TEFLON	1
9	17115	GUIDE, DISC SPRING.....	1
10	17116	SPRING, DISC	1
11	17117	RING, SPRING RETAINER	1
12	17122	SEAT, O-RING SEAL	1
√ 13	17102	PLATE, SOLENOID NAME	1
√ 14	17103	COVER, COIL HOUSING.....	1
√ 15	17104	WASHER, COIL.....	2
√ 16	17105	YOKE, COIL	1
√ 17	18706	COIL, 208-240V, 60 Hz.....	1
√ 17	18726	COIL, 208-240V, 50 Hz.....	1
√ 18	17123	HOUSING, COIL	1
√ 19	17108	BONNET, SOLENOID.....	1
√ 20	17113	BODY, SOLENOID VALVE	1
√ 21	17118	ADAPTER, PIPE	1
√ 22	SC01-132	SCREW, ADAPTER.....	2

√ recommended parts

* not shown

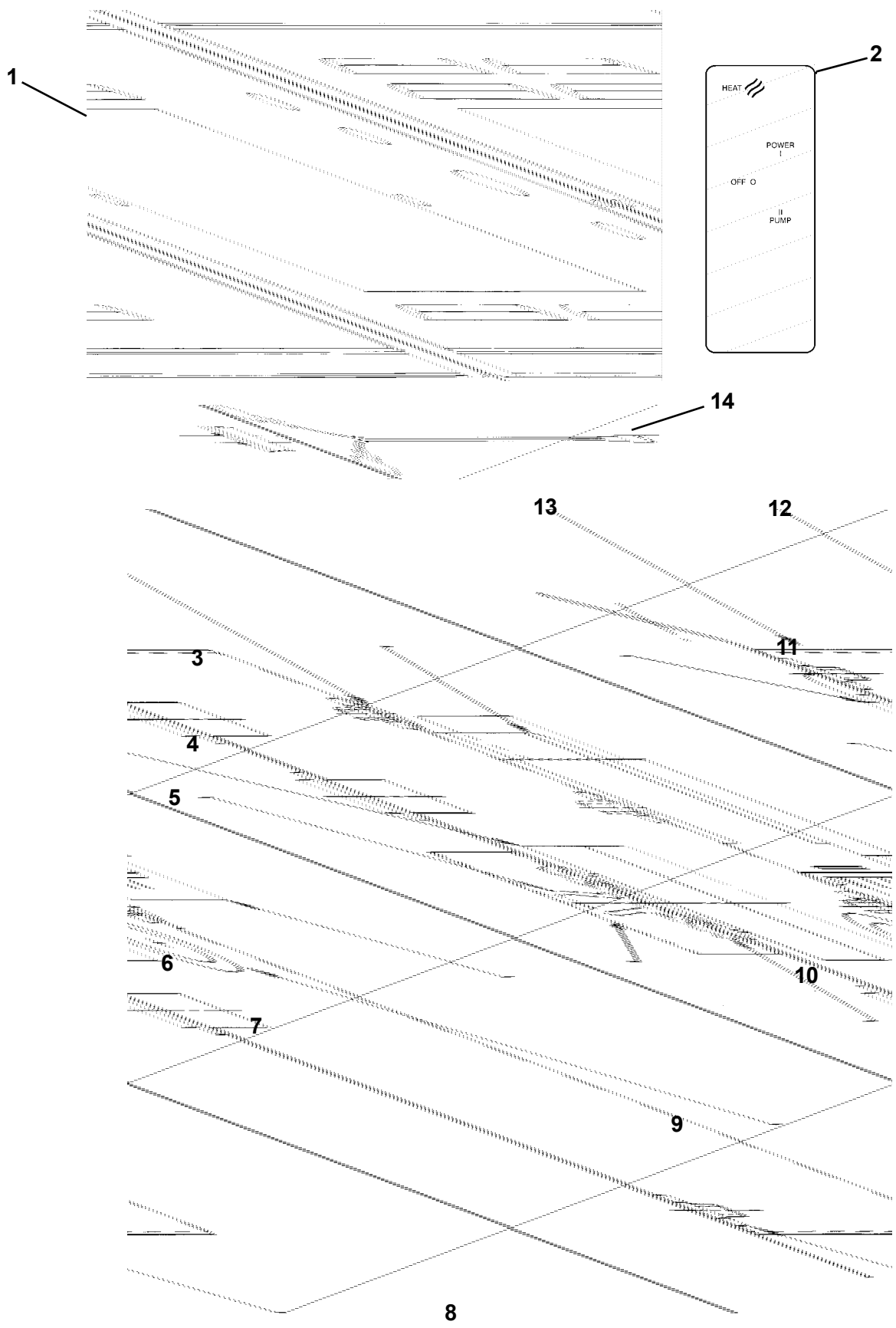

3-8. FAST READY PARTS

Figure & Item No.	Part No.	Description	Qty.
3-8		FAST READY PARTS	
1	23806	ASSY - CONTROL PANEL CE- 592	1
1	23805	ASSY - STUD-CONTROL - 592	1
2	51292	DECAL - FAST CONTROL.....	1
√ 3	54085	LIGHT - CE INDICATOR, GREEN	3
√ 3	16624	LIGHT - INDICATOR, RED.....	3
√ 4	16640	SWITCH MAIN ASSY - 4 PDT.....	1
5	48369	SWITCH COVER	1
6	18450	GUARD - SWITCH FRYER.....	1
7	NS03-018	NUT - 3/4-32 JAM	2
8	NS02-007	NUT HEX KEPS #8-32 C	10
9	EF02-002	BUSHING 33/64 P	1
√ 10	30614	TRANSFORMER - 208/240V PRI-24 VS.....	1
√ 11	30429	RELAY - 15A-125VAC, 10A-250VAC	1
12	SC01-034	SCREW #8-32 X 3/8 PH THD S.....	6
13	29921	BOX - SHIELD	1
√ 14	29948	ASSY - PROBE FAST ELECTRIC	1

√ recommended parts

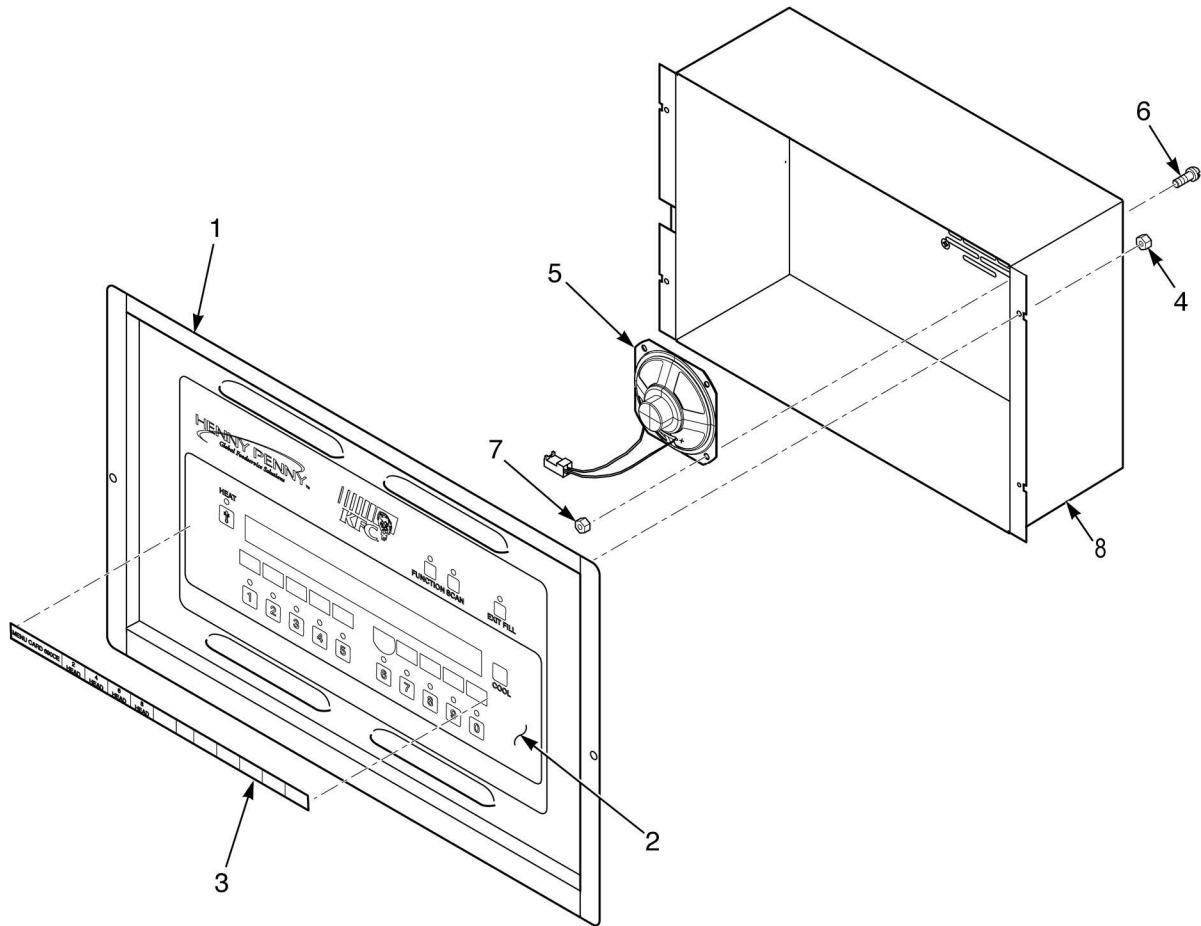

Figure & Item No.	Part No.	Description	Qty.
3-9		CONTROL PANEL ASSEMBLY	
√ 1	70949RB	CONTROL ASSY-590 SMS-W/O SETPOINTS-INT'L....	1
√ 1	23720RB	CONTROL ASSY – KFC 590 SMS - US DOM.....	1
2	50624	CONTROL DECAL – 8 HEAD KFC.....	1
3	54922	MENU CARD	1
3	78950	MENU CARD-INTERNATIONAL	1
4	NS02-005	NUT	4
√ 5	51877	WIRE/SPEAKER ASSY.....	1
6	SC01-049	. SCREW	4
7	NS02-005	. NUT.....	4
8	72500	.ASSY – CONTROL COVER STUD	1
9*	14621	KIT - CONTROL RETRO - 592 TO 590.....	1

√ recommended part/* not shown

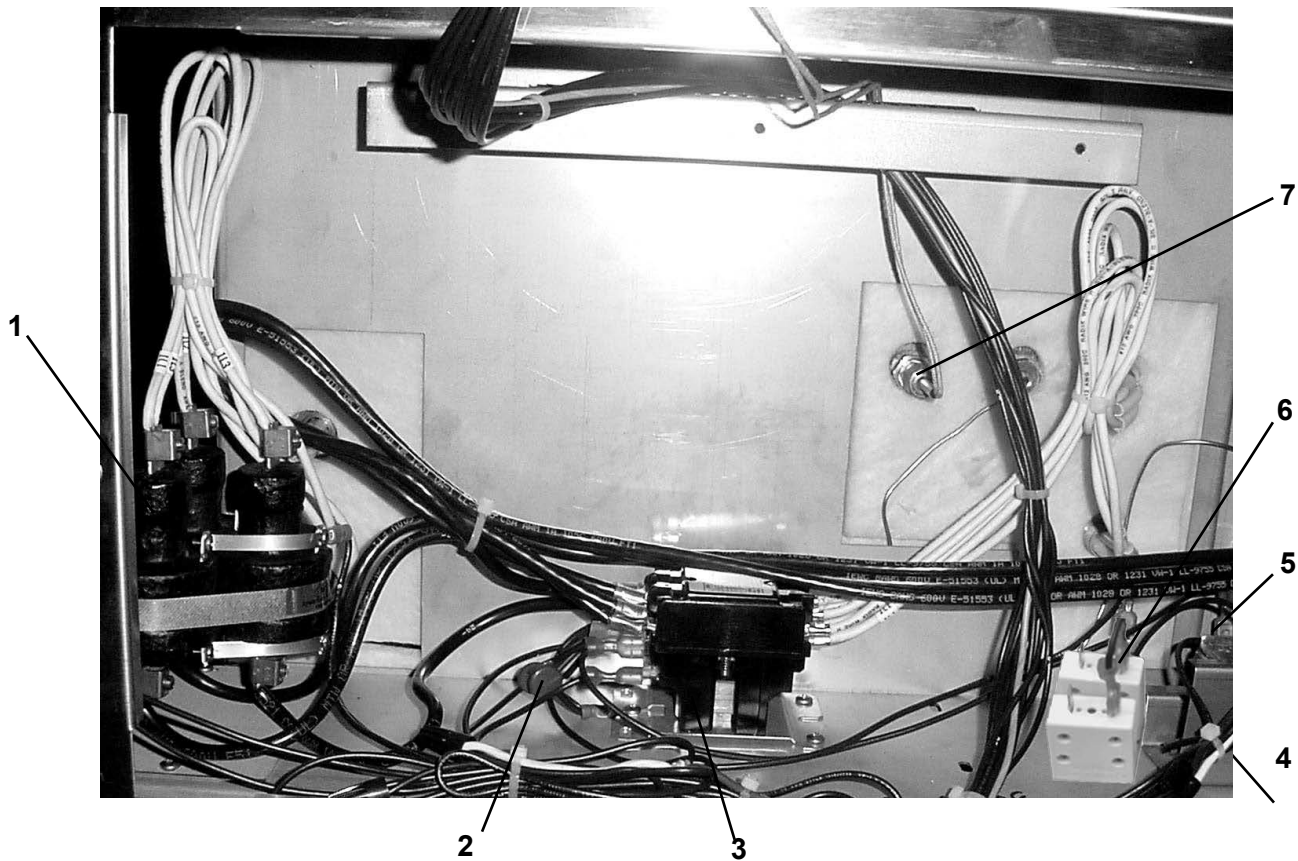
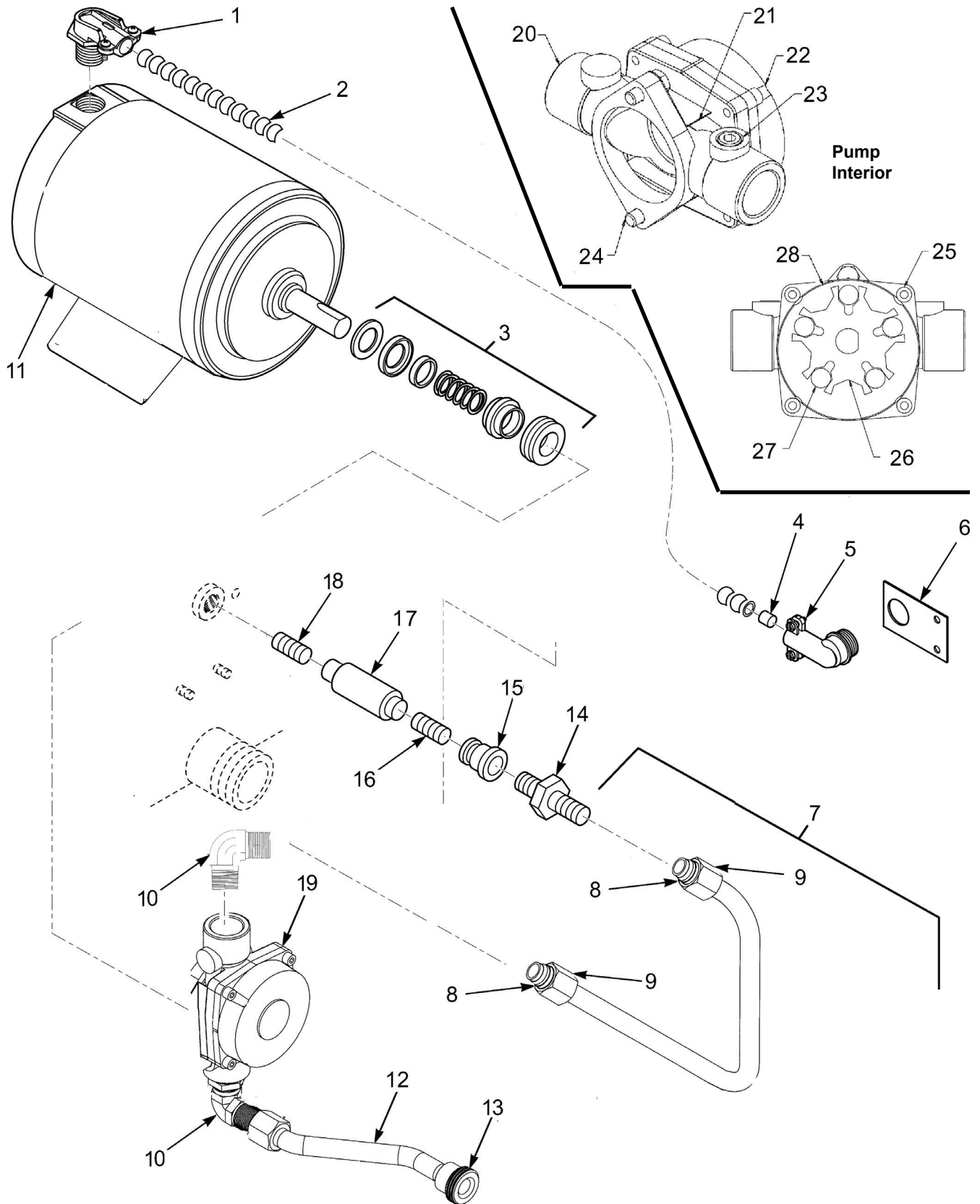

Figure & Item No.	Part No.	Description	Qty.
3-10		BEHIND CONTROL PANEL COMPONENTS	
√ 1	29942	CONTACTOR - MERCURY 208/240 VAC..... (BEFORE SN: AC0909001)	1
√ 1*	65075	E/M HEAT CONTACTOR - NON-CE - 240V (SN: AC0909001 AND ABOVE & ALL UK UNITS)	1
√ 1*	77574	E/M HEAT CONTACTOR - NON-CE - 208V (SN: AC0909001 AND ABOVE & ALL UK UNITS)	1
√ 1*	65074	E/M HEAT CONTACTOR - CE - 220-230V (SN: AC0909001 AND ABOVE)	1
√ 2	30971	CAPACITOR-RESISTOR ASSY.....	1
√ 3	19405	CONTACTOR KIT - 208/240 VAC.....	1
4	17216	BRACKET ASSY- HIGH LIMIT.....	1
√ 5	16738	450° F HIGH LIMIT.....	1
√ 5	60241	425° F HIGH LIMIT - CE.....	1
√ 6	EF02-125	BREAKER-PUSH BUTTON RESET-15 AMP..... SN: AC0608031& ABOVE- Non-CE units (10/4/07 and After - CE units)	2
√ 6	18364	FUSE HOLDER ASSY - 15 AMP..... (SN: AC0608030 & BELOW - Non-CE units)	2
√ 6	EF02-006	FUSE HOLDER.....	2
√ 6	EF02-007	FUSE - 15 AMP.....	2
√ 6	EF02-104	FUSE HOLDER - 20A-250V-CE (Before 10/4/07)...	1
√ 6	EF02-105	FUSE - 15 AMP - CE (Before 10/4/07).....	1
√ 7	14335	PROBE KIT.....	1

√ recommended parts/* not shown



3-11A. FILTER PUMP ASSEMBLY (SN: LG012JC & BELOW)

Figure & Item No.	Part No.	Description	Qty.
3-11A		FILTER PUMP ASSY (SN: LG012JC & BELOW)	
1	18107	CONDUIT CONNECTOR 3/8 X 90	1
2	54484	BLOWER/PUMP – FLEXIBLE CONDUIT	1
√ 3	17476	PUMP SEAL KIT	1
4	18105	ANTI SHORT 3/8 INCH	2
5	18644	CONDUIT CONNECTOR 3/8 X 90	1
6	51831	PUMP CONDUIT BRACKET	1
7	55836	ASSY – OIL RETURN LINE	1
8	16808	SLEEVE, FITTING	2
9	16809	NUT, FITTING	2
10	17407	CONNECTOR, 1/2 MALE ELBOW	2
√ 11	67583	MOTOR – FILTER PUMP - 1/2 HP	1
12	14669	KIT - FILTER PUMP RETURN LINE	1
12	62206	ASSY - TUBE - PUMP TO DISCON - 590	1
√ 13	17430(use69289)	UNION, MALE FITTING	1
14	16807	FITTING, CONNECTOR MALE	1
15	FP01-122	REDUCER, 3/8 TO 1/2	1
16	FP02-024	NIPPLE, CLOSE 3/8	1
√ 17	35472	CHECK VALVE - PRESSURE	1
18	FP02-007	NIPPLE 3/8 X 1-1/2	1
19	17437	PUMP SUBASSY 5 GPM	1
√ 20	17454	BODY - PUMP	1
√ 21	17456	PUMP SHIELD	2
√ 22	17451	COVER - PUMP	1
√ 23	SC01-016	PLUG 1/4 HEX COUNTERSUNK	1
√ 24	SC01-026	SCREW 5/16-18 X 3/4 HEX HD C	2
√ 25	SC01-132	1/4-20 X 5/8 SOC HD CAP SCREW	4
√ 26	17447	ROTOR - PUMP	1
√ 27	17446	ROLLER - TEFLON SET	1
28	17453	PUMP O RING GASKET	1
29*	67589	ASSY - FILTER PMP & 1/2 HP MOTOR	1

√ recommended part

* not shown

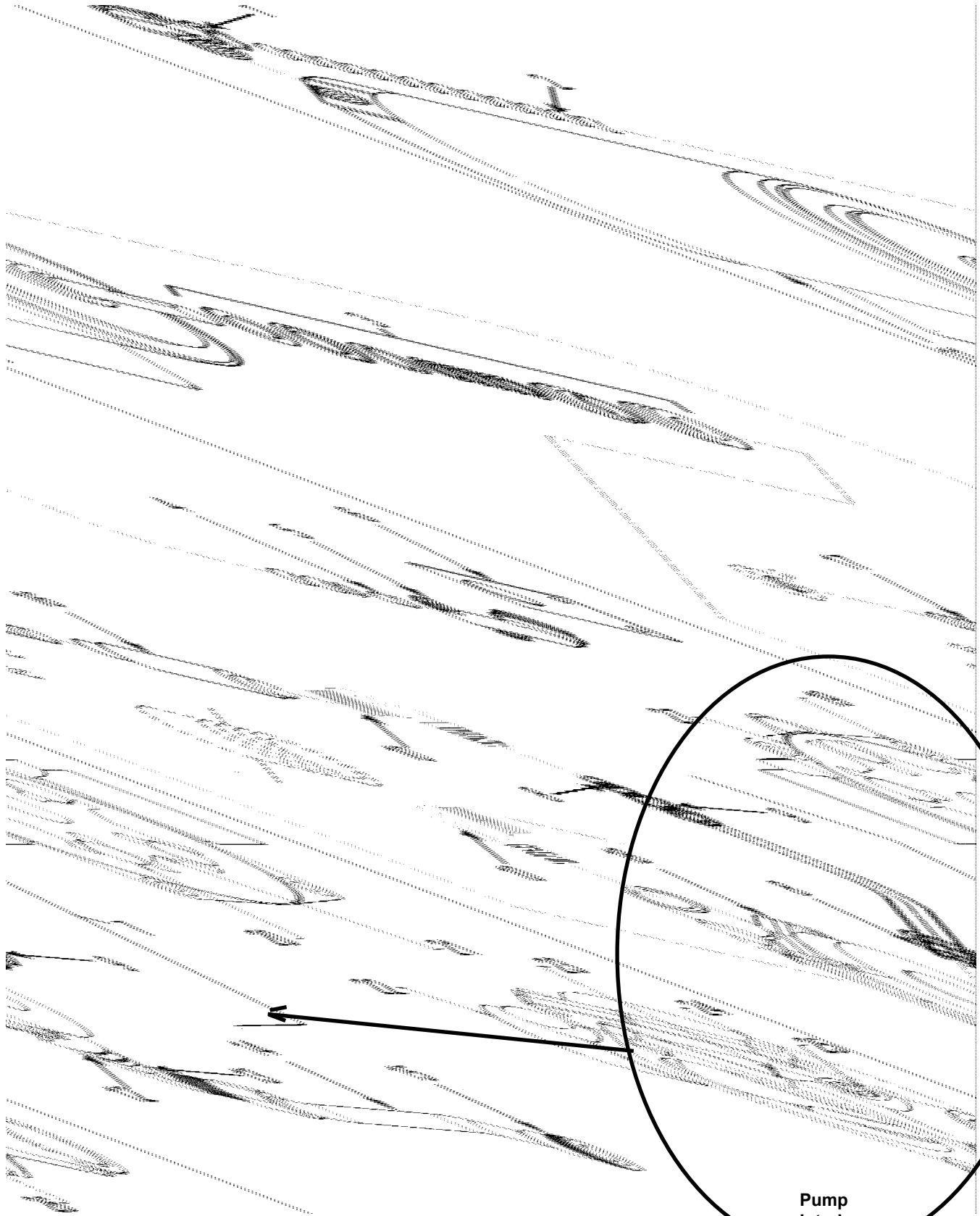

3-11B. FILTER PUMP ASSEMBLY (SN: LG013JC & ABOVE)

Figure & Item No.	Part No.	Description	Qty.
3-11B		FILTER PUMP ASSY (SN: LG013JC & ABOVE)	
1	18107	CONDUIT CONNECTOR 3/8 X 90	1
2	54484	BLOWER/PUMP – FLEXIBLE CONDUIT	1
√ 3	17476	PUMP SEAL KIT	1
4	18105	ANTI SHORT 3/8 INCH	2
5	18644	CONDUIT CONNECTOR 3/8 X 90	1
6	51831	PUMP CONDUIT BRACKET	1
7	66618	ASSY – OIL RETURN LINE.....	1
8	N/A	SLEEVE, FITTING	2
9	N/A	NUT, FITTING	2
10	FP01-169	CON-90 MALE 3/4 TUBE 3/4 NPT	2
√ 11	67583	MOTOR – FILTER PUMP - 1/2 HP.....	1
12	FP01-089	BUSHING - REDUCING 3/4M TO 1/2F.....	1
13	17407	CONNECTOR, 1/2 MALE ELBOW.....	1
14	62206	ASSY - TUBE - PUMP TO DISCON - 590	1
√ 15	17430(use69289)	UNION, MALE FITTING.....	1
√ 16	21800	VALVE - 3/4 CHECK.....	1
17	FP02-021	NIPPLE - 3/4 NPT X 3 IN LG BL.....	1
17	FP02-033	SN: AC0805020 AND BELOW NIPPLE - 3/4 NPT X 4 IN LG BL.....	1
18	64218	SN: AC0805021 AND ABOVE PUMP SUBASSY 8GPM	1
√ 19	SC01-132	1/4-20 X 5/8 SOC HD CAP SCREW.....	4
√ 20	23469	ROLLER - 8 GPM PUMP.....	5
√ 21	23468	ROTOR - 8 GPM PUMP.....	1
√ 22	23647	BODY - 8 GPM PUMP.....	1
√ 23	17456	PUMP SHIELD.....	2
√ 24	23470	CAP - 8 GPM PUMP.....	1
√ 25	FP01-020	PLUG 1/4-18 HEX LEVEL SEAL	1
√ 26	SC01-026	SCREW 5/16-18 X 3/4 HEX HD C	2
√ 27	17453	PUMP O RING GASKET.....	1
28*	69356	ASSY - 3/4" PUMP & MOTOR.....	1

√ recommended part

* not shown

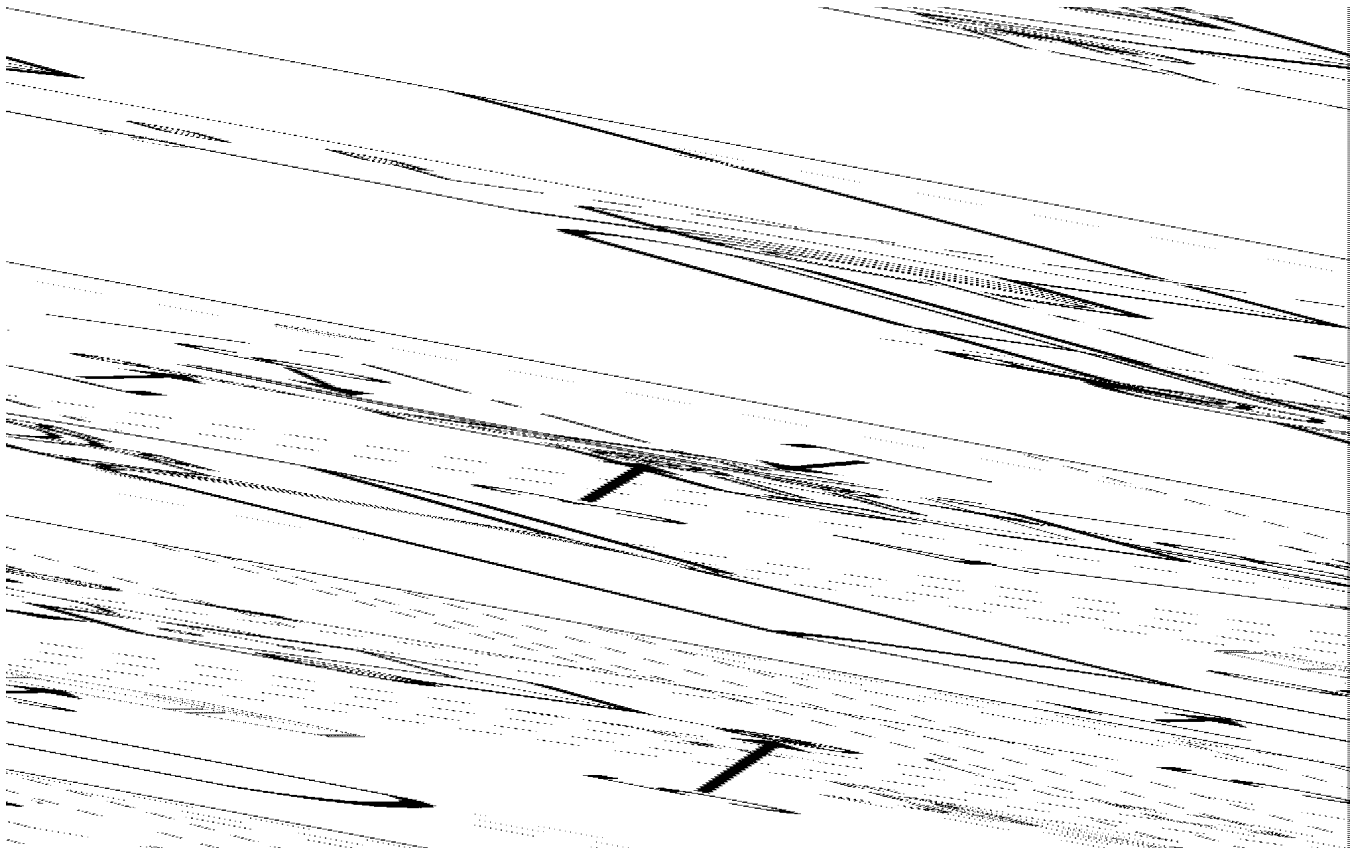

Figure & Item No.	Part No.	Description	Qty.
3-12		DRAIN VALVE & DRAIN SWITCH ASSEMBLIES	
1	65520	DRAIN VALVE ASSEMBLY (SN: LG012JC & BELOW)	1
1	66553	DRAIN VALVE ASSEMBLY (SN: LG013JC & ABOVE)	1
2	SC01-058	SCREW #6-32 X 1 PH. PAN HD.	2
3	WA01-006	WASHER #6 TYPE A.....	2
√ 4	54228	DRAIN SWITCH W/BOOT.....	1
5	NS02-005	NUT #6-32 HEX.....	2
6	52519	CORD ASSY., DRAIN INTERLOCK.....	1
7	65522	BRACKET, SWITCH (SN:AC0404025 & BELOW).....	1
7	67619	BRACKET, SWITCH (SN:AC0404026 & ABOVE).....	1
8	EF02-017	STRAIN RELIEF.....	2
9	67617	BRACKET - MICROSWITCH TRIGGERING.....	1
10*	76579	PLATE - D/I SWITCH COVER.....	1

√ recommended part

Figure & Item No.	Part No.	Description	Qty.
3-13		DRAIN PAN & FILTER ASSEMBLY	
1	52194	CRUMB CATCHER (OPTIONAL).....	1
2*	03203	CRUMB CATCHER BASKET W/HANDLE..... (OPTIONAL) (FITS INSIDE FRYPOT)	1
2	21471	CRUMB CATCHER BASKET ASSY.....	1
2	24491	HANDLE - CRUMB BASKET.....	1
3	52496	FILTER DRAIN PAN ASSEMBLY.....	1
4	52487	CASTER.....	2
5	SC01-009	SCREW 1/4-20 X 1/2.....	8
6	NS02-002	NUT 1/4-20.....	8
7	17505	FILTER CLIPS.....	2
8	17503(use 14674)	BOTTOM FILTER SCREEN..... (SN:AC0503055 AND BELOW)	1
8	65447	BOTTOM FILTER SCREEN-SS..... (SN: AC0503056 AND UP)	1
9	17502(use 14674)	TOP FILTER SCREEN..... (SN:AC0503055 AND BELOW)	1
10	36305	WASHER- STANDPIPE (USE WITH ITEM 1).....	1
11	24212	STANDPIPE ASSEMBLY..... (SN:AC0503055 AND BELOW)	1
11	14658	KIT, 8 HEAD PICK-UP TUBE..... (SN AC0503056 & ABOVE)	1
√ 12	17431(use 69289)	UNION - MALE FITTING.....	1
√ 13	17432(use 69289)	UNION - HANDLE FITTING.....	1
14	24211	WELDMENT, FILTER TUBE AND WASHER.....	1
15	23740	HANDLE, STANDPIPE 8 HEAD.....	1
16	SC01-245	SCREW 10-32 X 1/2.....	3
17	23804	INSERT, FILTER NUT.....	1
18	OR01-007	O-RING, FILTER NUT INSERT.....	1
19	23803	FILTER NUT (SN:AC0503055 AND BELOW).....	1
19	66535	FILTER NUT (SN AC0503056 & ABOVE).....	1
20	62082	FILTER DRAIN PAN COVER ASSEMBLY.....	1
√ 21	12102	FILTER ENVELOPE PAPER (100 PER CARTON).....	1
22	65776	ROD - LONG CLEAN OUT.....	1
√ 23	35771	BRUSH.....	1
24	35310	STIRRER.....	1
√ 25	12126	BLACK L-BRUSH.....	1
26	65211	CRUMB CATCHER - SS.....	1
27*	14895	KIT-SPCL. SHORT FILTER-KFC/FALCON.....	1

√ recommended parts

* not shown

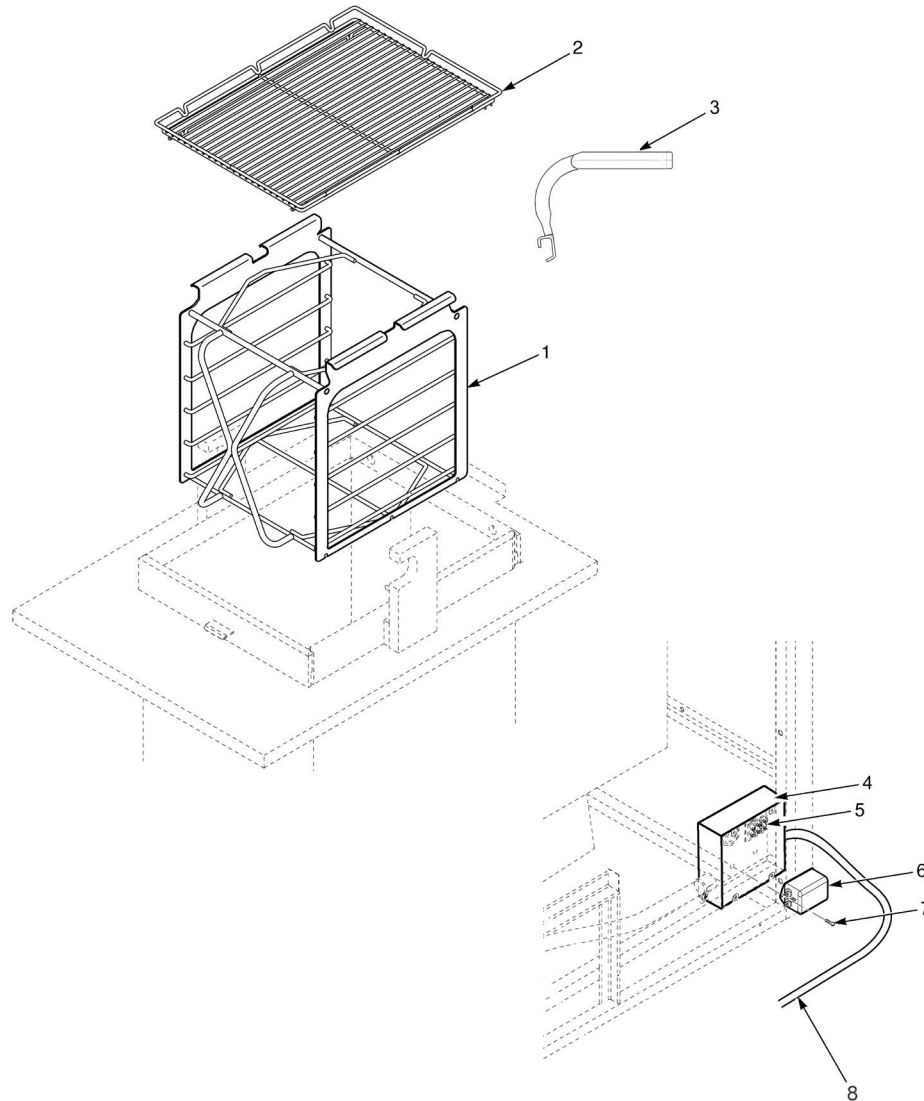

Figure & Item No.	Part No.	Description	Qty.
3-14		CARRIER, RACKS & JUNCTION BOX ASSY	
1	35194	CARRIER ASSY	1
2	44782	RACK HALF SIZE – 8 HEAD FRYER.....	5
3	35308	WELDMENT - RACK HANDLE.....	1
4	62126	JUNCTION BOX ASSY.....	1
4	62127	JUNCTION BOX ASSY - CE	1
5	65427	ASSY - 5-POLE TERMINAL BLOCK - CE	1
√ 6	51057	ASSY - EMC FILTER - CE.....	1
7	SC01-023	SCREW #6-32 X 1/4 PH RHD C	8
8	65180	ASSY - MAIN POWER CORD	1
8	65181	CORD - 291/591 POWER.....	1
9*	58146	PLUG-90, 60A, 3PH, 250V, #15-60P	1
10*	37560	RECEPTACLE #15-60R.....	1
11*	70824	ASSY - CE GROUNDING LUG.....	1

√ recommended parts/* not shown

