

SECTION 3. PARTS INFORMATION

3-1. INTRODUCTION

This section lists the replaceable parts of the Henny Penny Model 591 fryer.

3-2. GENUINE PARTS

Use only genuine Henny Penny parts in your fryer. Using a part of lesser quality or substitute design may result in damage to the unit or personal injury.

3-3. WHEN ORDERING PARTS

Once the parts that you want to order have been found in the parts list, write down the following information:

Item Number	<u>2</u>	Example:
Part Number	<u>16738</u>	
Description	High Limit	

From the data plate, list the following information:

Product Number	<u>01100</u>	Example:
Serial Number	<u>0001</u>	
Voltage	208	

3-4. PRICES

Your distributor has a price parts list and will be glad to inform you of the cost of your parts order.

3-5. DELIVERY

Commonly replaced items are stocked by your distributor and will be sent out when your order is received. Other parts will be ordered, by your distributor, from Henny Penny Corporation. Normally, these will be sent to your distributor within three working days.

3-6. WARRANTY

All replacement parts (except lamps and fuses) are warranted for 90 days against manufacturing defects and workmanship. If damage occurs during shipping, notify the carrier at once so that a claim may be properly filed. Refer to warranty in the front of this manual for other rights and limitations.

3-7. RECOMMENDED SPARE PARTS FOR DISTRIBUTORS

Recommended replacement parts, stocked by your distributor, are indicated with √ in the parts lists. Please use care when ordering recommended parts, because all voltages and variations are marked. Distributors should order parts based upon common voltages and equipment sold in their territory.

3-8. INDEX OF PARTS LIST ILLUSTRATIONS

Title	Fig. No.	Page No.
FRAME & COVER ASSEMBLY.....	3-1	3-3
ELEMENT ASSEMBLY	3-2	3-5
COUNTERWEIGHT SYSTEM	3-3	3-6
LID & COVER ASSEMBLY	3-4	3-7
STEAM BOX & HOSE ASSEMBLY	3-5	3-9
DEADWEIGHT & SOLENOID ASSEMBLY	3-6	3-10
SOLENOID VALVE ASSEMBLY	3-7	3-12
CONTROL PANEL ASSEMBLY.....	3-9	3-14
BEHIND CONTROL PANEL COMPONENTS	3-10	3-15
FILTER PUMP ASSEMBLY (SN: LG012JC & BELOW)	3-11A	3-16
FILTER PUMP ASSEMBLY (SN: LG013JC & ABOVE).....	3-11B	3-18
OPTIONAL RINSE HOSE ATTACHMENTS (SN: LG012JC & BELOW)	3-12A	3-20
OPTIONAL RINSE HOSE ATTACHMENTS (SN: LG013JC & ABOVE).	3-12B	3-21
DRAIN VALVE & DRAIN SWITCH ASSEMBLIES.....	3-13	3-22
DRAIN PAN & FILTER ASSEMBLY	3-14	3-23
CARRIER, RACKS & JUNCTION BOX ASSY.....	3-15	3-25
OPTIONAL DIRECT-CONNECT KIT (SN: LG014JC & ABOVE).....	3-16	3-26

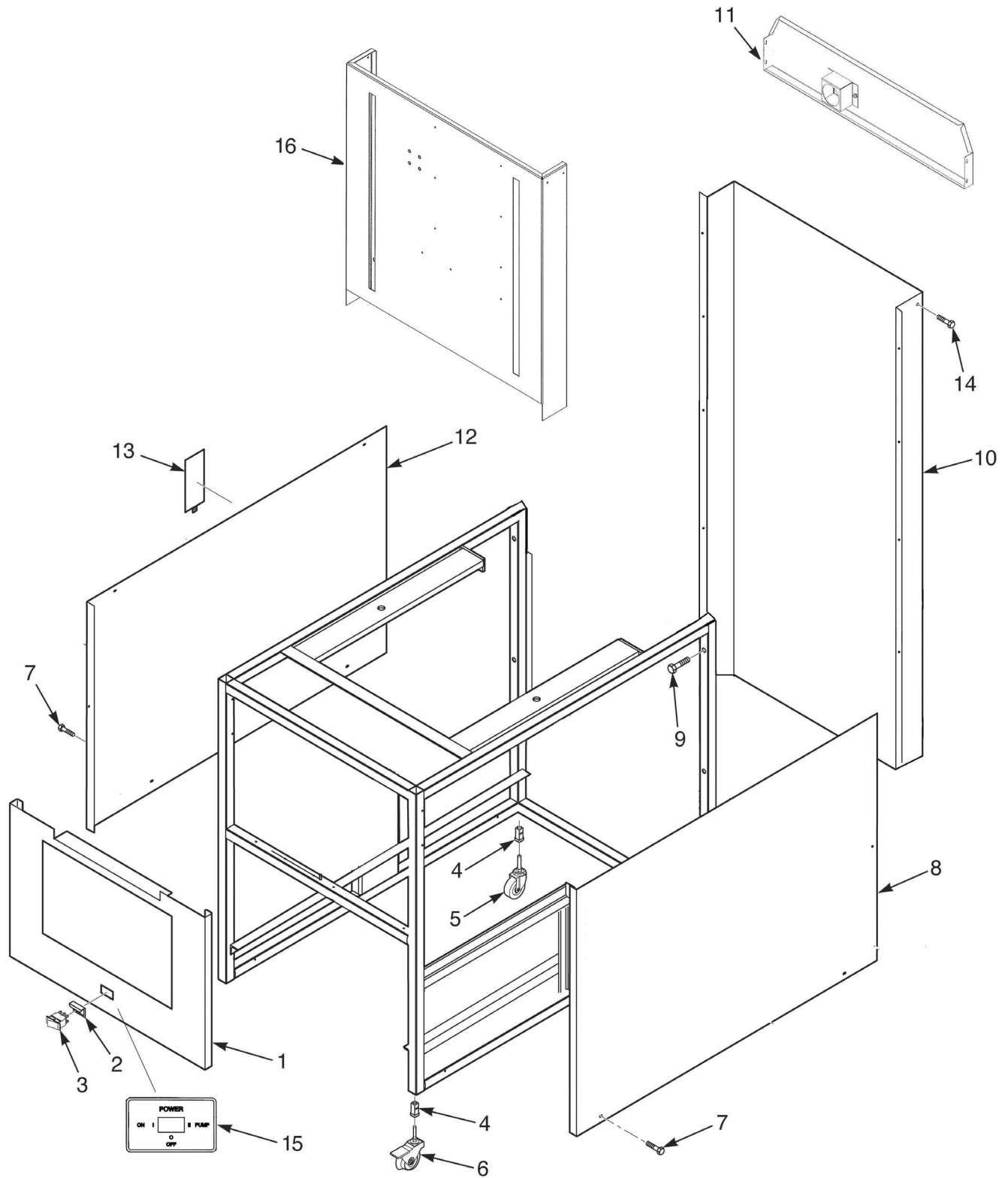

Figure 3-1. Frame and Cover Assembly

Figure & Item No.	Part No.	Description	Qty.
3-1		FRAME & COVER ASSEMBLY	
1	39796	WELDMENT – CONTROL PANEL FRONT.....	1
2	53669	GUARD – POWER SWITCH.....	1
√ 3	29898	SWITCH – POWER.....	1
4	54225	1” INSERT – LEG MACHINED.....	4
5	35154	CASTER, SWIVEL 4”.....	2
6	37246	CASTER W/BRAKE & SWIVEL LOCK.....	2
7	SC03-005	SCREW - - #8 x 1/2” PH PHD.....	4
8	66934	SIDE PANEL – RIGHT.....	1
9	SC01-215	SCREW - 5/16-18 x 2.5” HEX HD BOLT.....	4
10	37291	REAR SHROUD – ACCESS ASSEMBLY.....	1
11	35726	TOP COVER – REAR SHROUD.....	1
12	66933	SIDE PANEL – LEFT.....	1
12	14457	KIT - SOUND DEADENING.....	1
13	36337	DOOR – ACCESS.....	1
14	SC02-023	SCREW - #8-B x 3/8” PH THD SS.....	5
15	75696	LABEL - POWER/PUMP - ENGLISH.....	1
16	62085	REAR SHROUD.....	1

√ recommended part

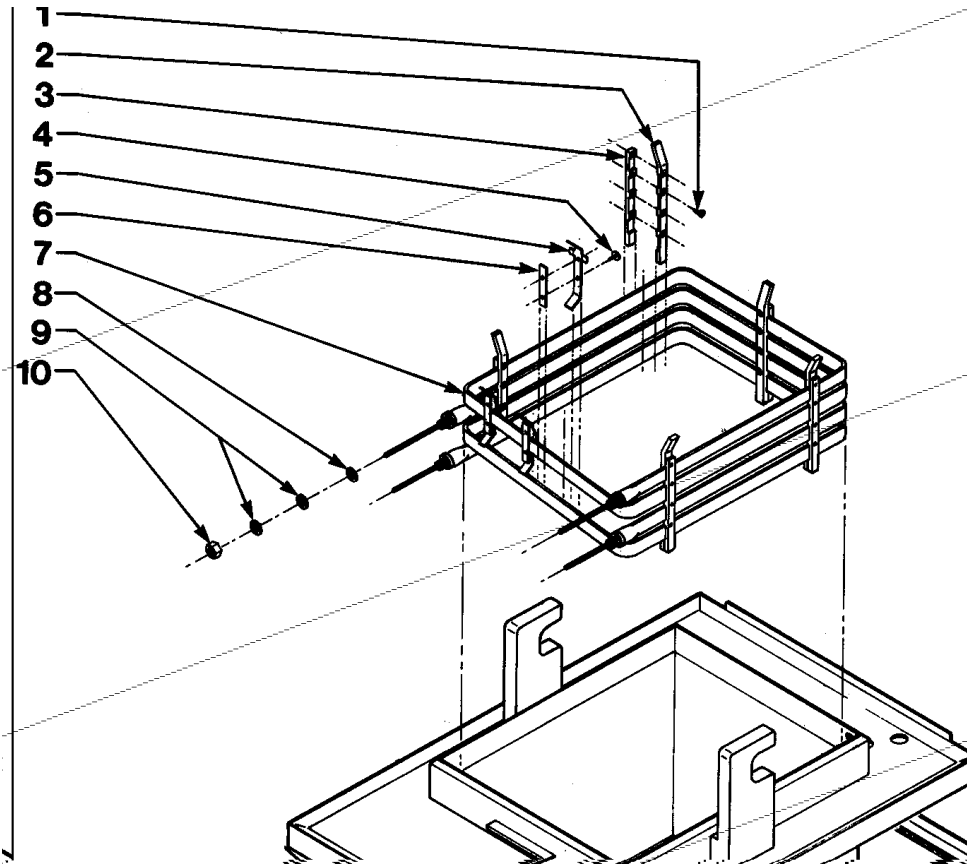

Figure & Item No.	Part No.	Description	Qty.
3-2		ELEMENT ASSEMBLY	
1	SC01-083	SCREW, (#10-32 x 1/2 PH FHD).....	As Required
2	35101	SUPPORT, ELEMENT - LONG.....	5
3	35100	SUPPORT, ELEMENT - SHORT.....	5
4	SC01-074	SCREW, (#10-32 x 1/2 PH THD S).....	As Required
5	35435	BRACKET, HI LIMIT PROBE.....	3
6	35462	BRACKET, HI LIMIT PROBE.....	3
√ 7	35234	HEAT ELEMENT ASSEMBLY, 8.5 KW 208V.....	2
√	35598	HEAT ELEMENT, 8.5 KW 240V.....	2
√	36407	HEAT ELEMENT, 8.5 KW 480V.....	2
√	48367	HEAT ELEMENT, 230 V(Int'l Only).....	2
√	36290	HEAT ELEMENT, 220 V(Int'l Only).....	2
8	16855	SEAL, O-RING.....	4
9	WA01-005	WASHER, (5/8 DIA. TYPE A - SERIES N).....	8
10	NS01-017	NUT, (5/8-18 B HEX).....	4

√ recommended part

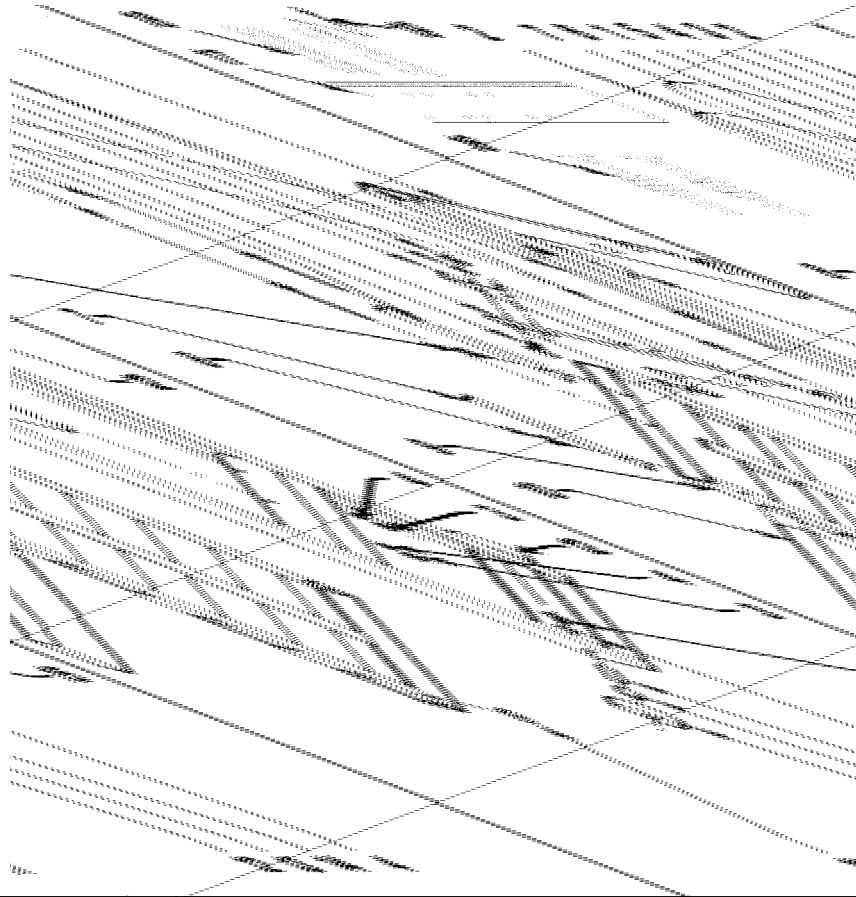
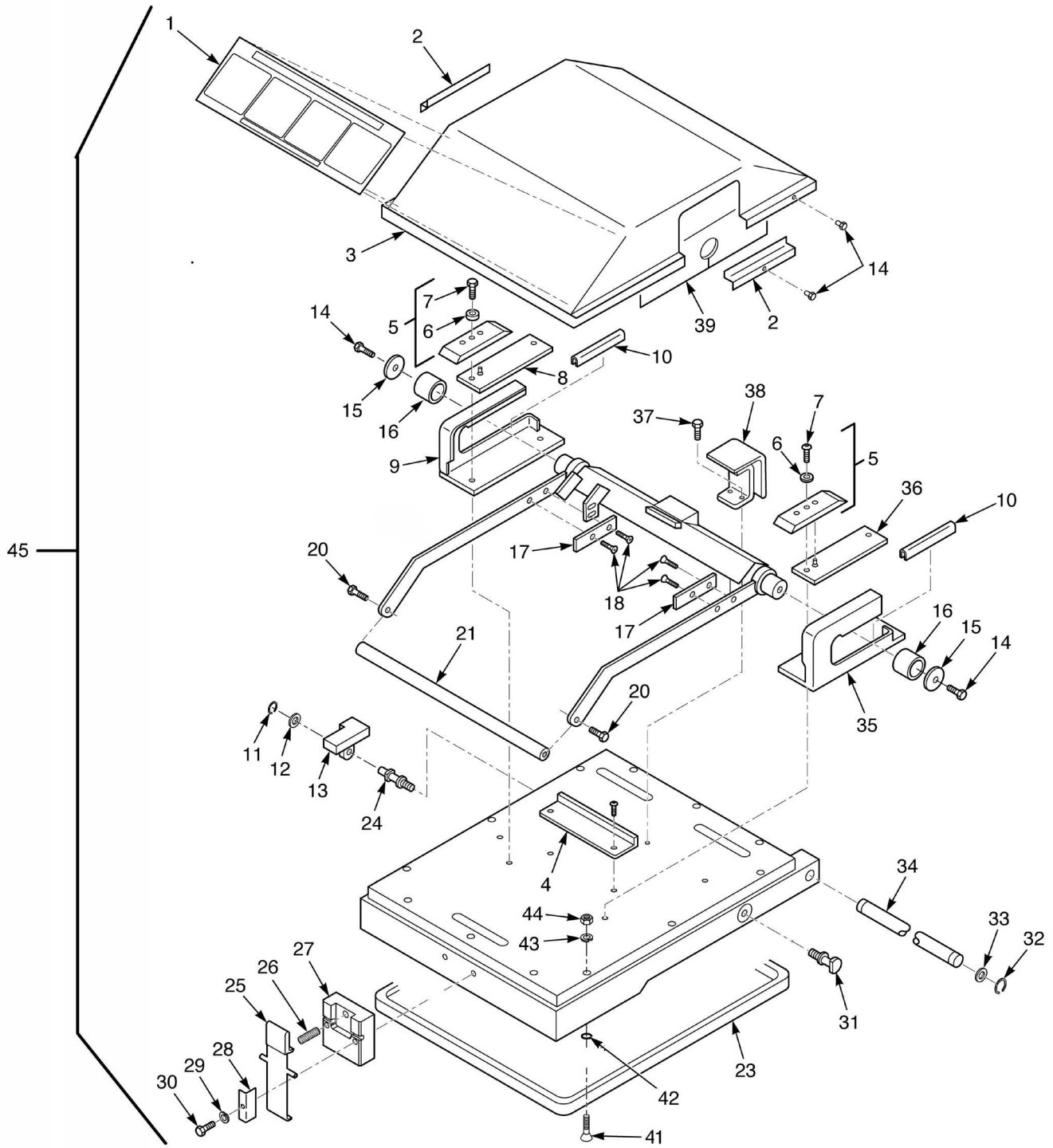

Figure & Item No.	Part No.	Description	Qty.
3-3		COUNTERWEIGHT SYSTEM	
1	35026	ARM, LID SUPPORT	2
√ 2	35207	CABLE	2
3	NS01-025	NUT, HEX 5/16-18 SS	10
4	LW01-010	WASHER, 3/8 SPLIT RING SS	10
5	35092	CARRIAGE	1
6	SC01-069	SCREW, 3/8-16 X 1-1/2 HEX HD S2P	8
7	36839	SLIDE	2
8	SC01-042	SCREW, 3/8-16 X 1 HEX C	2
9	36625	WELD ASSEMBLY, C/W CARRIAGE	1
10	36627	COUNTERWEIGHT BAR	7
11	36626	SPACER, C/W FRAME	2
12	37362	WHEEL, CARRIAGE	4
13	37363	SPACER, CARRIAGE WHEEL	4
14	37364	SPINDLE	4
15	SC01-081	SCREW, 3/8-24 X 3/4 HEX HD SS	4
16	35962	BRACKET/WHEEL ASSY	2
17	36561	BRACE, TOP FRAME	1
18	35954	PLATE, SUPPORT PULLEY	4
19	SC01-132	SCREW, CAP, SOC HD, 1/2-20 X 5/8	8

√ recommended part



3-4. LID & COVER ASSEMBLY

Figure & Item No.	Part No.	Description	Qty.
3-4		LID & COVER ASSEMBLY	
1	35792	LID INSTRUCTION LABEL.....	1
2	35675	FILLER-LID.....	2
3	35243	COVER-MAIN LID.....	1
4	35413	PLATE-TRIP.....	1
√ 5	52627	PRESSURE PAD ASSY.	2
6	49852	BUSHING-PRESSURE PAD.....	2
7	SC01-204	SCREW 1/4-20X1.00 SOCK BUTT.....	2
8	49962	PLATE, SHIM ASSY. (L.H.).....	1
9	49890	PLATE, CAM GUIDE (L.H.).....	1
10	35359	SLIDE (6").....	2
11	RR01-004	RING, RETAINING 1/2".....	1
12	WA01-020	WASHER, LID STOP.....	1
13	51531	CAST, LID STOP.....	1
14	SC01-074	SCREW, #10-32 x 1/2 PH THD SS.....	8
15	35223	WASHER, SPECIAL.....	1
16	35227	ROLLER, LINKAGE SHAFT.....	2
17	35339	GUIDE, HANDLE SIDE.....	2
18	SC01-062	SCREW, #6-32 x 3/8 PH FH.....	4
20	SC01-041	SCREW, 5/16-18 x 1.00 HEX HD C.....	2
21	36285	WELDMENT, HANDLE TAP PLATE.....	1
√ 23	34526	GASKET, LID - SN: AC0712021 & below.....	1
√ 23	66620	GASKET, LID - SN: AC0712022 & above.....	1
24	35945	PIN, LID SUPPORT.....	1
25	52497	LATCH ASSEMBLY, COATED.....	1
26	52498	LATCH SPRING.....	1
27	59169	LATCH BRACKET, LID (MACHINED).....	1
28	51707	LATCH BRACKET, LID.....	2
29	LW02-006	LOCKWASHER, LATCH.....	2
30	SC01-248	SCREW, LATCH, 10-32 x 1.25 PH THD SS.....	2
31	35032	PIN, LID SUPPORT.....	1
32	RR01-010	RING, RET. 3/4 SHAFT SS.....	2
33	36312	WASHER, LID HINGE.....	2
34	51697	PIN, LID HINGE.....	1
35	49895	PLATE, CAM GUIDE (R.H.).....	1
36	49963	PLATE SHIM ASSEMBLY (R.H.).....	1
37	SC01-146	SCREW, 1/4-20 x 3/4 HEX HD SS.....	2
38	52477	LIFT, LID.....	1
√ 39	35465	CAM SLIDE FILLER.....	2
41	SC01-195	SCREW, 8-32 x 1-7/16 PH FHD S.....	12
42	OR01-005	O-RING, 5/16 x 1/16 DIA.....	12
43	LW01-002	LOCKWASHER, SPLIT RING 1/4 S.....	12
44	NS01-008	NUT, 8-32 HEX.....	12
45	79418	ASSY - REBUILT LID.....	1

√ recommended part

* not shown

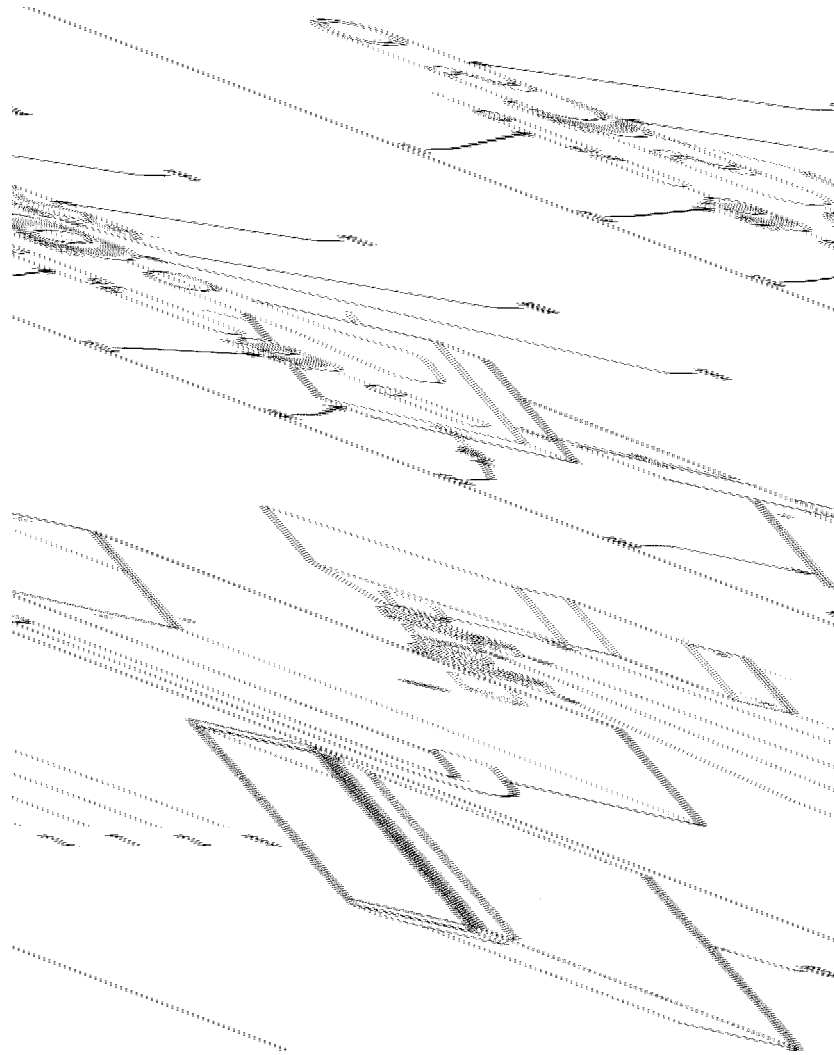
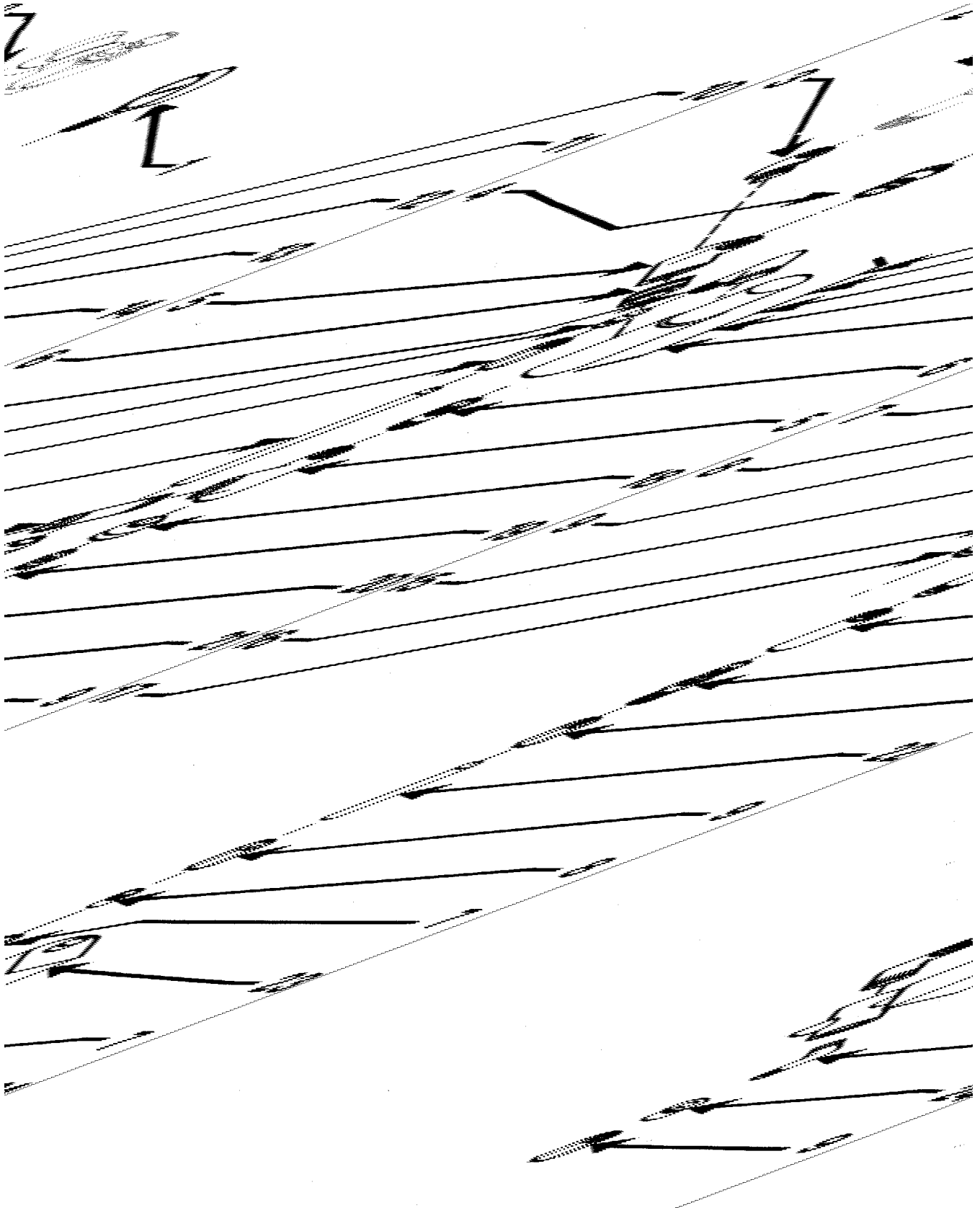

Figure & Item No.	Part No.	Description	Qty.
3-5		STEAM BOX & HOSE ASSY	
1	35686	TUBE, DW TO EXHAUST STACK SS.....	1
2	MS01-297	HOSE CLAMP, SS - .500 – 1.062 DID	4
3	35693	TUBE, EXHAUST CONNECT	1
4	35696	WELDMENT, STEAM EXHAUST BOX LID	1
5	SC02-041	SCREW, #8-18 X 7/16 PH IND XTRNL TRX	4
6	66732	WELDMENT, STEAM EXHAUST BOX.....	1
7	82517	HOSE, CONDENSATE (SN: AC0903045 & ABOVE)	1
7	66723	TUBE, CONDENSATE (SN: IG048JC - AC0903044)	1
7	62211	TUBE, CONDENSATE (SN: IG047JC & BELOW).....	1
8	69263	RESTRICTOR	1
9	MS01-315	HOSE CLAMP, ½ X 1-3/4 SS	2
10	NS01-011	NUT, (#10-32 HEX).....	1
11	36851	BRACKET, HOSE	1
12	21877	TUBING, STEAM EXHAUST.....	4
13	71409	CONDENSATE PAN WELDMENT	1
14*	EF02-118	2 HOLE CONDUIT CLAMP 1” EMT (cond. hose).....	1

* not shown



3-6. DEADWEIGHT & SOLENOID ASSEMBLY

Figure & Item No.	Part No.	Description	Qty.
3-6		DEADWEIGHT & SOLENOID ASSY	
√ 1	16910	PRESSURE GAUGE.....	1
√ 2	59742	RELIEF VALVE ASSY	1
3	FP01-127	ELBOW, STREET, ½ X ½, 90 DEGREE	1
4	FP01-063	REDUCER, ½ NPT M TO ¼ NPT F.....	1
5	FP01-011	PIPE TEE, ½ NPT 304 SS.....	2
6	FP01-028	NIPPLE, CLOSE ½ NPT.....	2
7	17407	CONNECTOR, ½ MALE ELBOW	3
8	16817	FITTING, SLEEVE TEFLON.....	As Required
9	16809	NUT FITTING.....	As Required
10	56307	CAP, DEAD WEIGHT	1
11	16902	SEAL "O" RING	1
12	16904	DEAD WEIGHT - 9 PSI	1
12	65449	DEAD WEIGHT - 3 PSI	1
13	16906	ORIFICE, 9 PSI.....	1
14	16852	BODY, VALVE.....	1
15	35686	TUBE, DW TO EXHAUST STACK.....	1
16	35817	PIPE NIPPLE, ½ X 2 ¼ SS	1
17	16804	UMBRELLA GROMMET	1
18	35200	UMBRELLA GRAMMET	1
19	35474	PIPE NIPPLE, ½ X 2.....	1
20	FP01-066	COUPLING, ½ NPT SS	1
21	16807	FITTING CONNECTOR, MALE	1
22	35147	TUBE, STEAM EXHAUST - UP	1
23	29515	VALVE, SOLENOID 24V, 60HZ.....	1
23	29698	VALVE, SOLENOID 24V, 50HZ.....	1
24	16808	FITTING SLEEVE, STEEL.....	1

√ recommended part

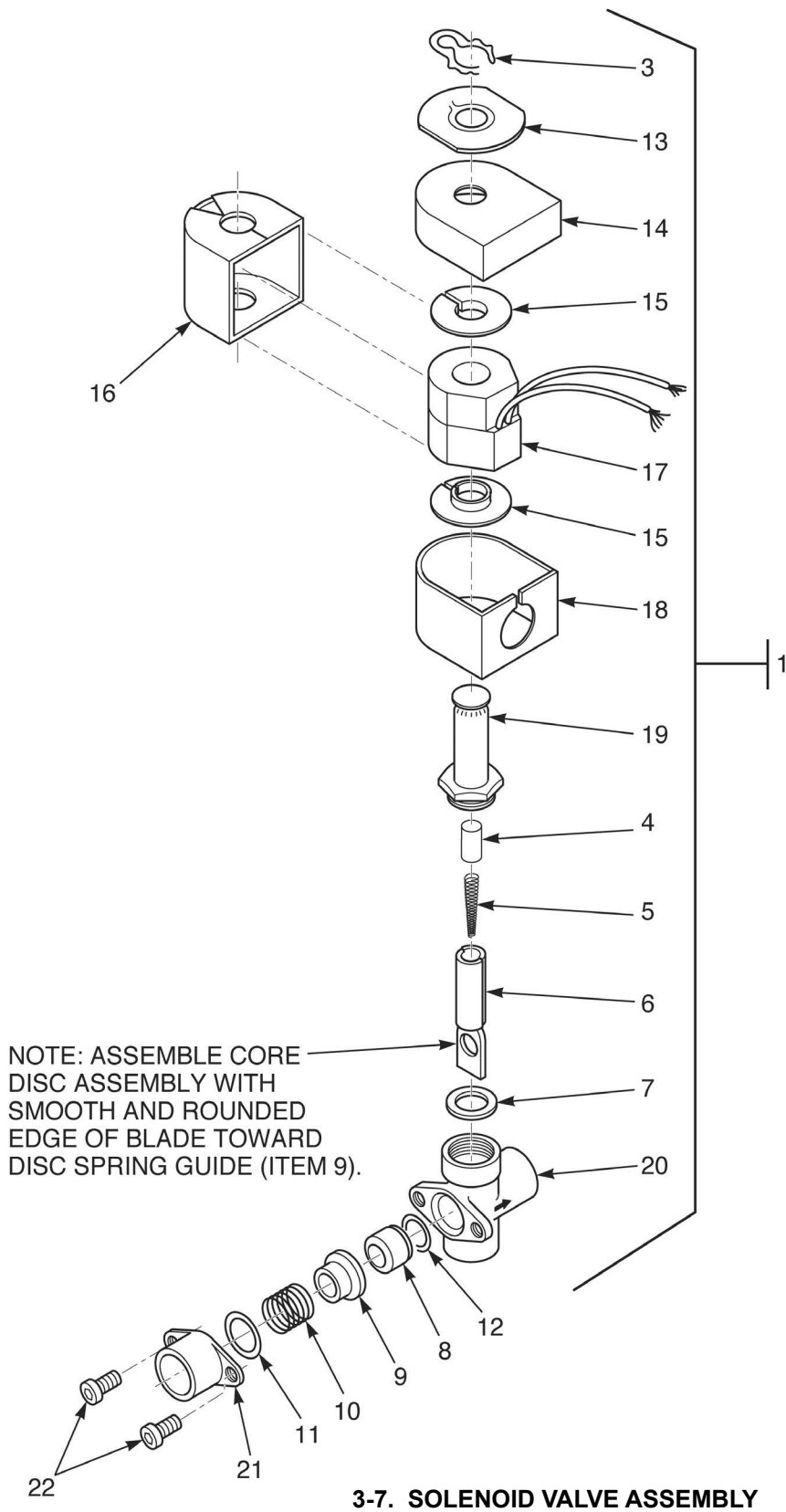

Figure & Item No.	Part No.	Description	Qty.
3-7		SOLENOID VALVE ASSEMBLY	
1	29515	VALVE, SOLENOID 24V, 60 Hz.....	1
1	29698	VALVE, SOLENOID 24V, 50 Hz.....	1
√ 2*	17120	KIT, SOLENOID VALVE REPAIR.....	1
3	17101	CLIP, RETAINER.....	1
4	17109	RETAINER, SPRING.....	1
5	17110	SPRING, CORE.....	1
6	17111	CORE, DISC ASSEMBLY.....	1
7	17112	GASKET, BONNET.....	1
8	17114	SEAT, TEFLON.....	1
9	17115	GUIDE, DISC SPRING.....	1
10	17116	SPRING, DISC.....	1
11	17117	RING, SPRING RETAINER.....	1
12	17122	SEAT, O-RING SEAL.....	1
√ 13	17102	PLATE, SOLENOID NAME.....	1
√ 14	17103	COVER, COIL HOUSING.....	1
√ 15	17104	WASHER, COIL.....	2
√ 16	17105	YOKE, COIL.....	1
√ 17	29547	COIL, 24V, 60 Hz.....	1
√ 17	29575	COIL, 24V, 50 Hz.....	1
√ 18	17123	HOUSING, COIL.....	1
√ 19	17108	BONNET, SOLENOID.....	1
√ 20	17113	BODY, SOLENOID VALVE.....	1
√ 21	17118	ADAPTER, PIPE.....	1
√ 22	SC01-132	SCREW, ADAPTER.....	2

√ recommended part

* not shown

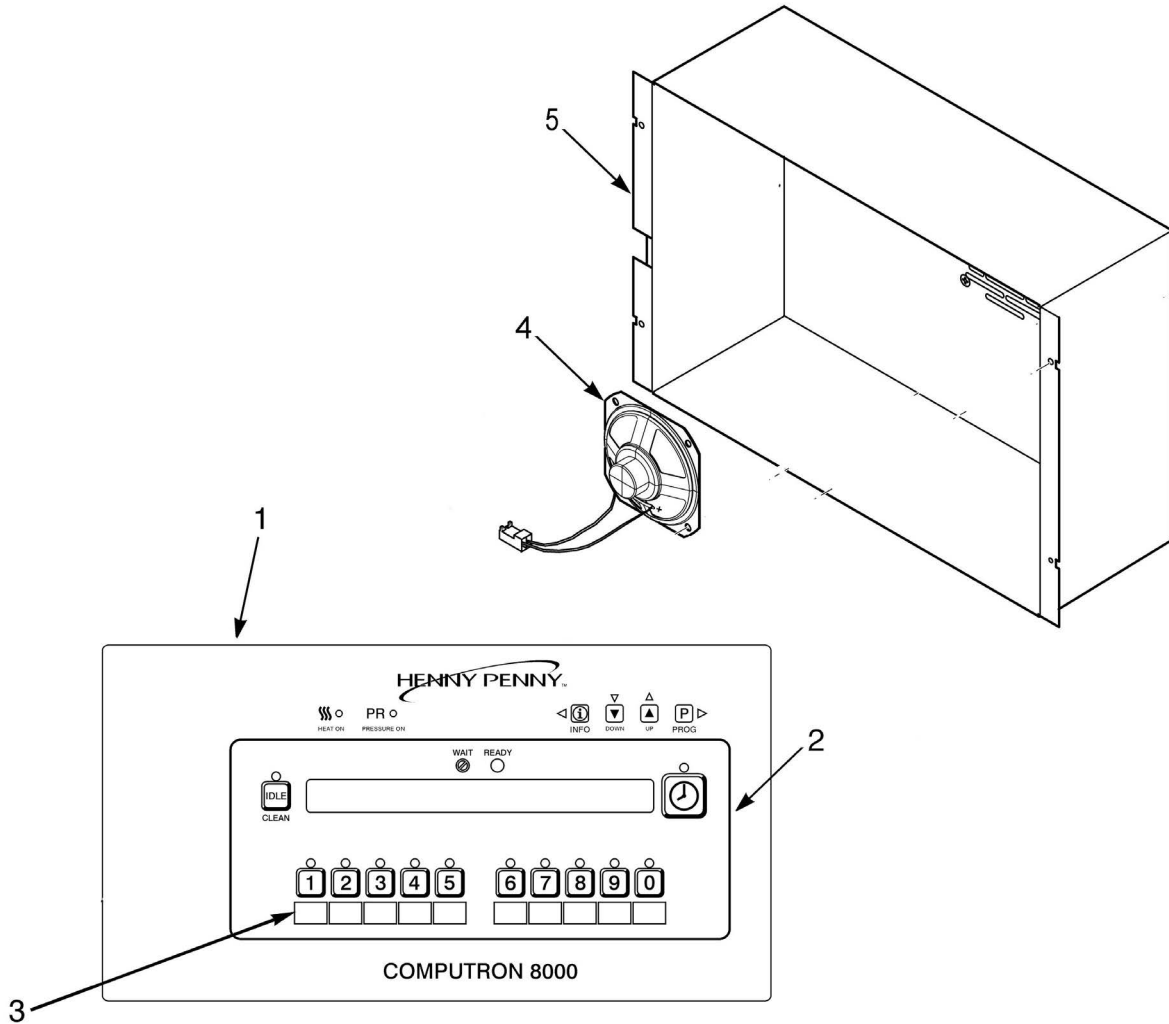

Figure & Item No.	Part No.	Description	Qty.
3-9		CONTROL PANEL ASSEMBLY	
√ 1	65279RB	ASSY - 8 HEAD C8000 CONTROL.....	1
2	65236	DECAL – 8 HEAD C8000	1
3	32634	MENU CARD C8000 BLANK.....	1
3	65922	MENU CARD C8000 8-HD HP GM	1
√ 4	26974	WIRE/SPEAKER ASSY	1
5	65661	STUD ASSY-8-HEAD-C8000- COVER.....	1
6*	65893RB	ASSY - I/O BOARD.....	1
7*	14686	KIT, 590 TO 591 CONVERSION - 60HZ.....	1
7*	14687	KIT, 590 TO 591 CONVERSION - 50HZ.....	1
7*	14690	KIT, 592 TO 591 CONVERSION - 60HZ.....	1
7*	14691	KIT, 592 TO 591 CONVERSION - 50HZ.....	1

√ recommended part/* not shown



Figure & Item No.	Part No.	Description	Qty.
3-10		BEHIND CONTROL PANEL COMPONENTS	
√ 1	29510	CONTACTOR - MERCURY 24V	1
		(BEFORE SN: AC0909001)	
√ 1*	65073	CONTACTOR - 24V (SN: AC0909001 & ABOVE).....	1
√ 2	29901	CAPACITOR-RESISTOR ASSY.....	1
√ 3	29509	CONTACTOR KIT - 24V	1
4	17216	BRACKET ASSY- HIGH LIMIT	1
√ 5	16738	450° F HIGH LIMIT	1
√ 5	60241	425° F HIGH LIMIT - CE.....	1
√ 6	EF02-125	BREAKER-PUSH BUTTON RESET-15 AMP	2
		SN: AC0608031& ABOVE- Non-CE units	
		(10/4/07 and After - CE units)	
√ 6	18364	FUSE HOLDER ASSY - 15 AMP	2
		(SN: AC0608030 & BELOW - Non-CE units)	
√ 6	EF02-006	FUSE HOLDER.....	2
√ 6	EF02-007	FUSE - 15 AMP	2
√ 6	EF02-104	FUSE HOLDER - 20A-250V-CE (Before 10/4/07).....	1
√ 6	EF02-105	FUSE - 15 AMP - CE (Before 10/4/07)	1
√ 7	140084	KIT, TEMPERATURE PROBE.....	1
√ 8*	72854	ASSY - TRANSFORMER - 24VAC - C8000.....	1

√ recommended part/* not shown

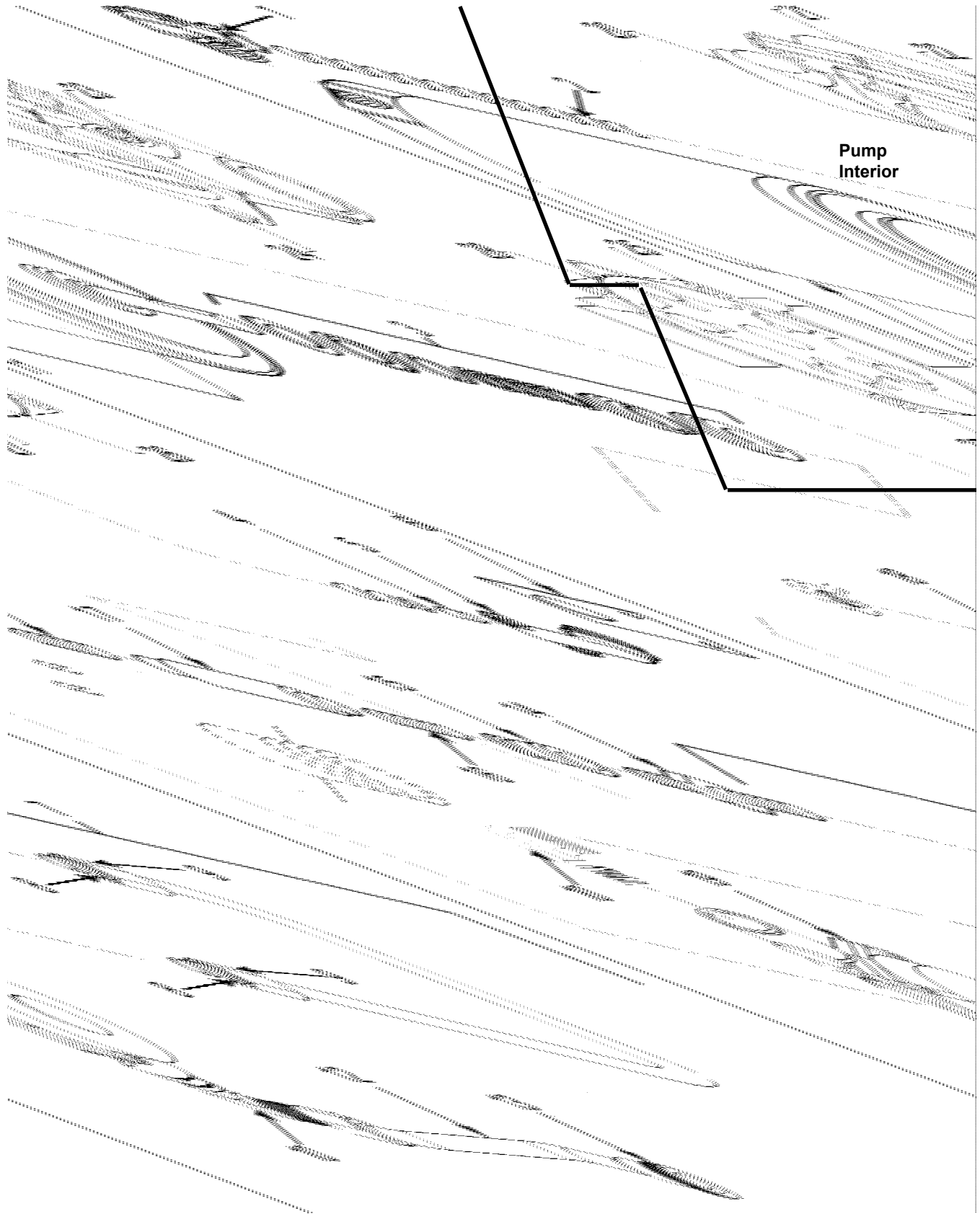

**Pump
Interior**

3-11A. FILTER PUMP ASSEMBLY (SN: LG012JC & BELOW)

Figure & Item No.	Part No.	Description	Qty.
3-11A		FILTER PUMP ASSY (SN: LG012JC & BELOW)	
1	18107	CONDUIT CONNECTOR 3/8 X 90	1
2	54484	BLOWER/PUMP – FLEXIBLE CONDUIT	1
√ 3	17476	PUMP SEAL KIT	1
4	18105	ANTI SHORT 3/8 INCH	2
5	18644	CONDUIT CONNECTOR 3/8 X 90	1
6	51831	PUMP CONDUIT BRACKET	1
7	55836	ASSY – OIL RETURN LINE.....	1
8	16808	SLEEVE, FITTING	2
9	16809	NUT, FITTING	2
10	17407	CONNECTOR, 1/2 MALE ELBOW.....	2
√ 11	67583	MOTOR – FILTER PUMP - 1/2 HP.....	1
12	14669	KIT - FILTER PUMP RETURN LINE.....	1
12	62206	ASSY - TUBE - PUMP TO DISCON - 590	1
√ 13	17430(use69289)	UNION, MALE FITTING.....	1
14	16807	FITTING, CONNECTOR MALE	1
15	FP01-122	REDUCER, 3/8 TO 1/2	1
16	FP02-024	NIPPLE, CLOSE 3/8	1
√ 17	35472	CHECK VALVE - PRESSURE	1
18	FP02-007	NIPPLE 3/8 X 1-1/2.....	1
19	17437	PUMP SUBASSY 5 GPM	1
20	17454	BODY - PUMP	1
21	17456	PUMP SHIELD.....	2
22	17451	COVER - PUMP.....	1
23	SC01-016	PLUG 1/4 HEX COUNTERSUNK	1
24	SC01-026	SCREW 5/16-18 X 3/4 HEX HD C.....	2
25	SC01-132	1/4-20 X 5/8 SOC HD CAP SCREW	4
26	17447	ROTOR - PUMP	1
27	17446	ROLLER - TEFLON SET	1
28	17453	PUMP O RING GASKET	1
29*	67589	ASSY - FILTER PMP & 1/2 HP MOTOR.....	1

√ recommended part

* not shown

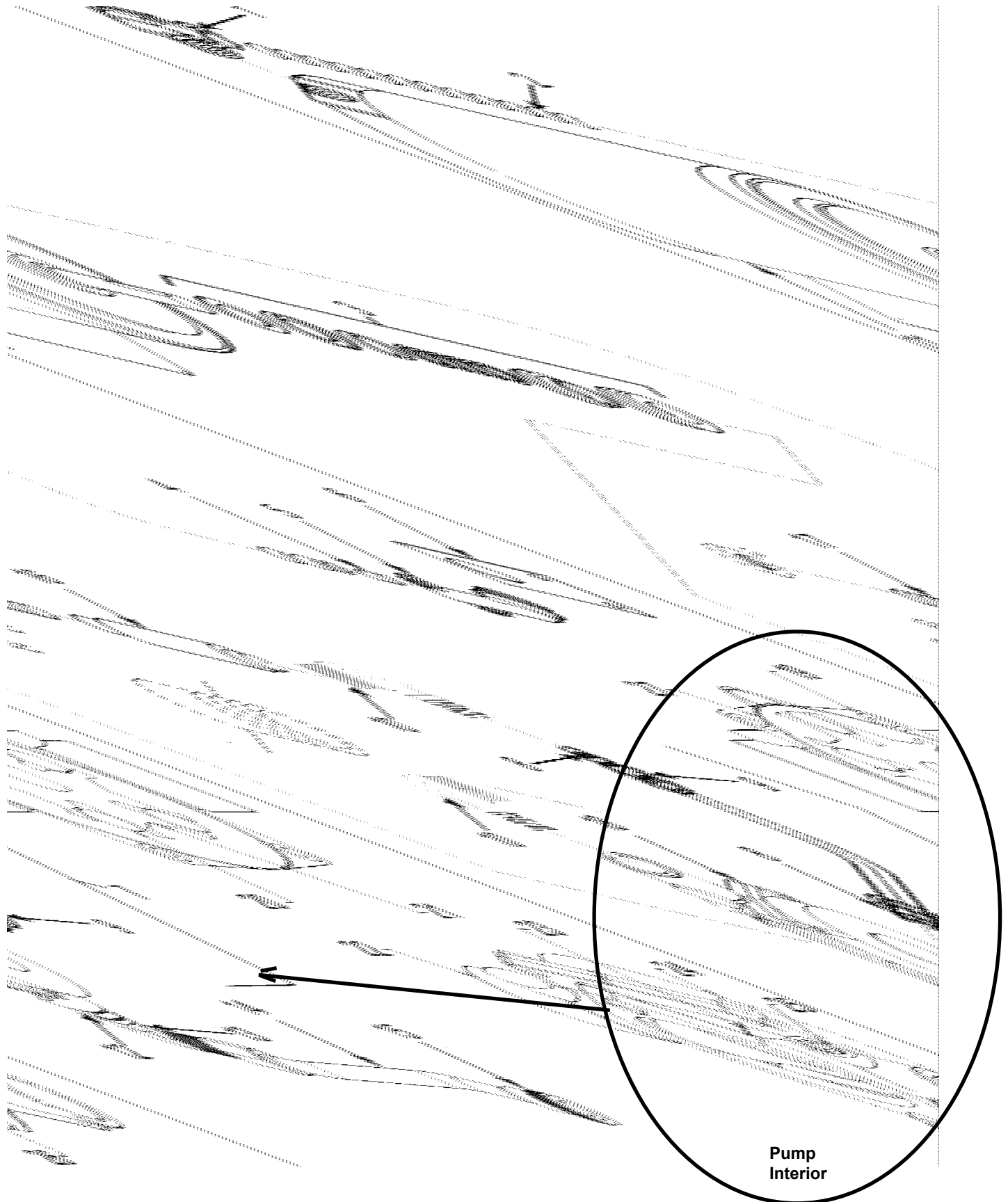

3-11B. FILTER PUMP ASSEMBLY (SN: LG013JC & ABOVE)

Figure & Item No.	Part No.	Description	Qty.
3-11B		FILTER PUMP ASSY (SN: LG013JC & UP)	
1	18107	CONDUIT CONNECTOR 3/8 X 90	1
2	54484	BLOWER/PUMP – FLEXIBLE CONDUIT	1
√ 3	17476	PUMP SEAL KIT	1
4	18105	ANTI SHORT 3/8 INCH	2
5	18644	CONDUIT CONNECTOR 3/8 X 90	1
6	51831	PUMP CONDUIT BRACKET	1
7	66618	ASSY – OIL RETURN LINE.....	1
8	N/A	SLEEVE, FITTING.....	2
9	N/A	NUT, FITTING.....	2
10	FP01-169	CON-90 MALE 3/4 TUBE 3/4 NPT	2
√ 11	67583	MOTOR – FILTER PUMP	1
12	FP01-089	BUSHING - REDUCING 3/4M TO 1/2F.....	1
13	17407	CONNECTOR, 1/2 MALE ELBOW.....	1
14	62206	ASSY - TUBE - PUMP TO DISCON - 590	1
√ 15	17430(use69289)	UNION, MALE FITTING.....	1
16	21800	VALVE - 3/4 CHECK.....	1
17	FP02-021	NIPPLE - 3/4 NPT X 3 IN LG BL.....	1
		SN: AC0805020 AND BELOW	
17	FP02-033	NIPPLE - 3/4 NPT X 4 IN BL.....	1
		SN: AC0805021 AND ABOVE	
18	64218	PUMP SUBASSY 8 GPM	1
√ 19	SC01-132	1/4-20 X 5/8 SOC HD CAP SCREW	4
√ 20	23469	ROLLER - 8 GPM PUMP	5
√ 21	23468	ROTOR - 8 GPM PUMP.....	1
√ 22	23647	BODY - 8 GPM PUMP	1
√ 23	17456	PUMP SHIELD.....	2
√ 24	23470	CAP - 8 GPM PUMP	1
√ 25	FP01-020	PLUG 1/4-18 HEX LEVEL SEAL	1
√ 26	SC01-026	SCREW 5/16-18 X 3/4 HEX HD C	2
√ 27	17453	PUMP O RING GASKET.....	1
28*	69356	ASSY - 3/4" PUMP & MOTOR.....	1

√ recommended part

* not shown

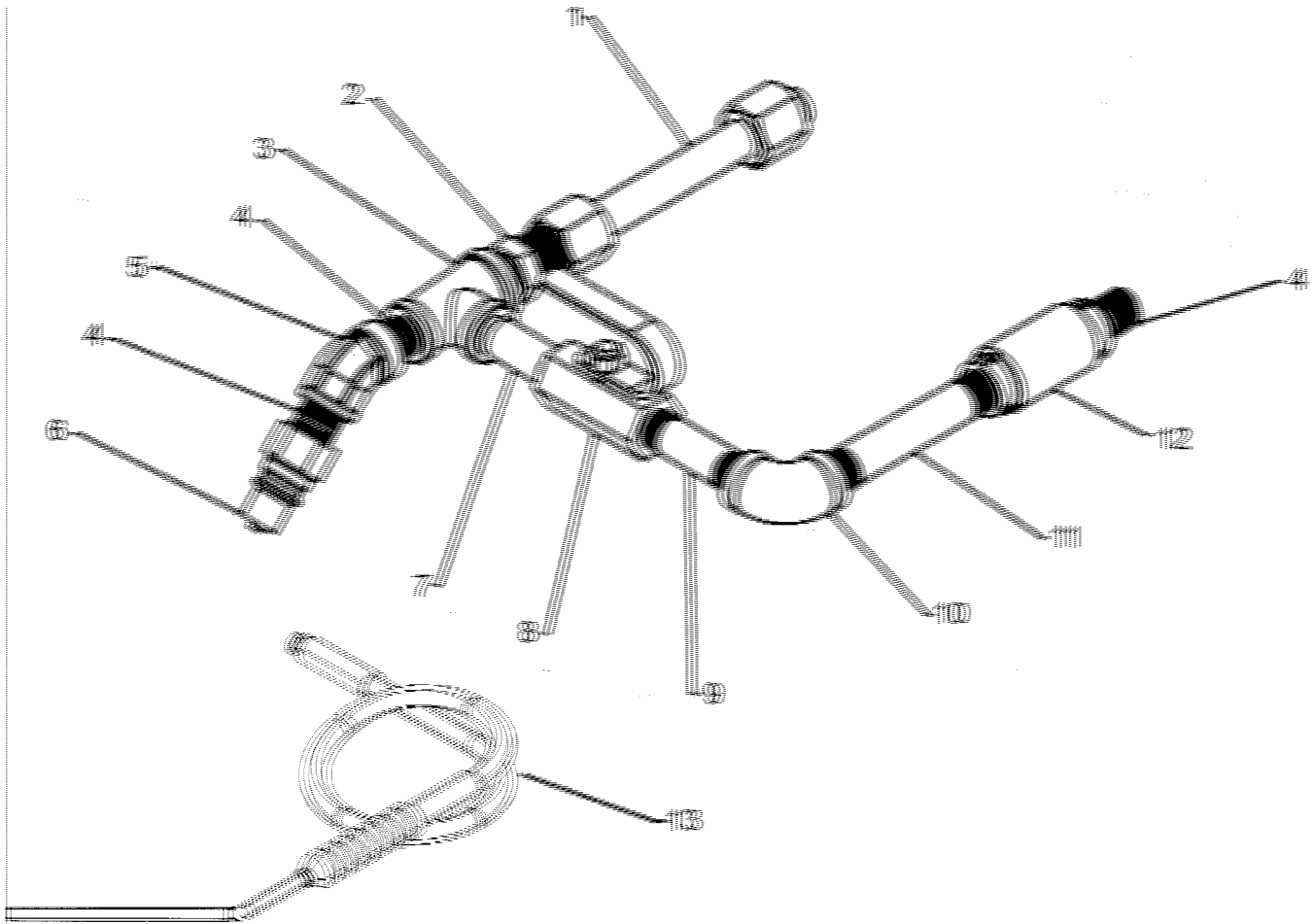

3-12A. OPTIONAL RINSE HOSE ATTACHMENTS (SN: LG012JC & BELOW)

Figure & Item No.	Part No.	Description	Qty.
3-12A		OPTIONAL RINSE HOSE ATTACHMENTS	
1	66677	ASSY - RINSE HOSE - TUBE - 591	1
2	16807	FITTING - MALE CONNECTOR.....	1
3	17306	PIPE TEE FITTING	1
4	FP02-024	NIPPLE - 3/8 NPT - CLOSE B. I.	3
5	FP01-133	ELBOW - 3/8 NPT X 45 - FEMALE	1
6	17334	RINSE HOSE DISCONNECT - MALE.....	1
7	FP02-042	NIPPLE - 3/8 X 2 LG B. I.	1
8	59185	VALVE - FILTER (SMALL C HANDLE).....	1
9	FP02-043	NIPPLE - 3/8 NPT X 2.5 B. I.	1
10	17319	PIPE ELBOW - 3/8.....	1
11	FP01-116	NIPPLE - 3/8 NPT X 4" LG B. I.	1
12	35472	CHECK VALVE - PRESSURE	1
13	03003	DETACHABLE HOSE ASSEMBLY	1

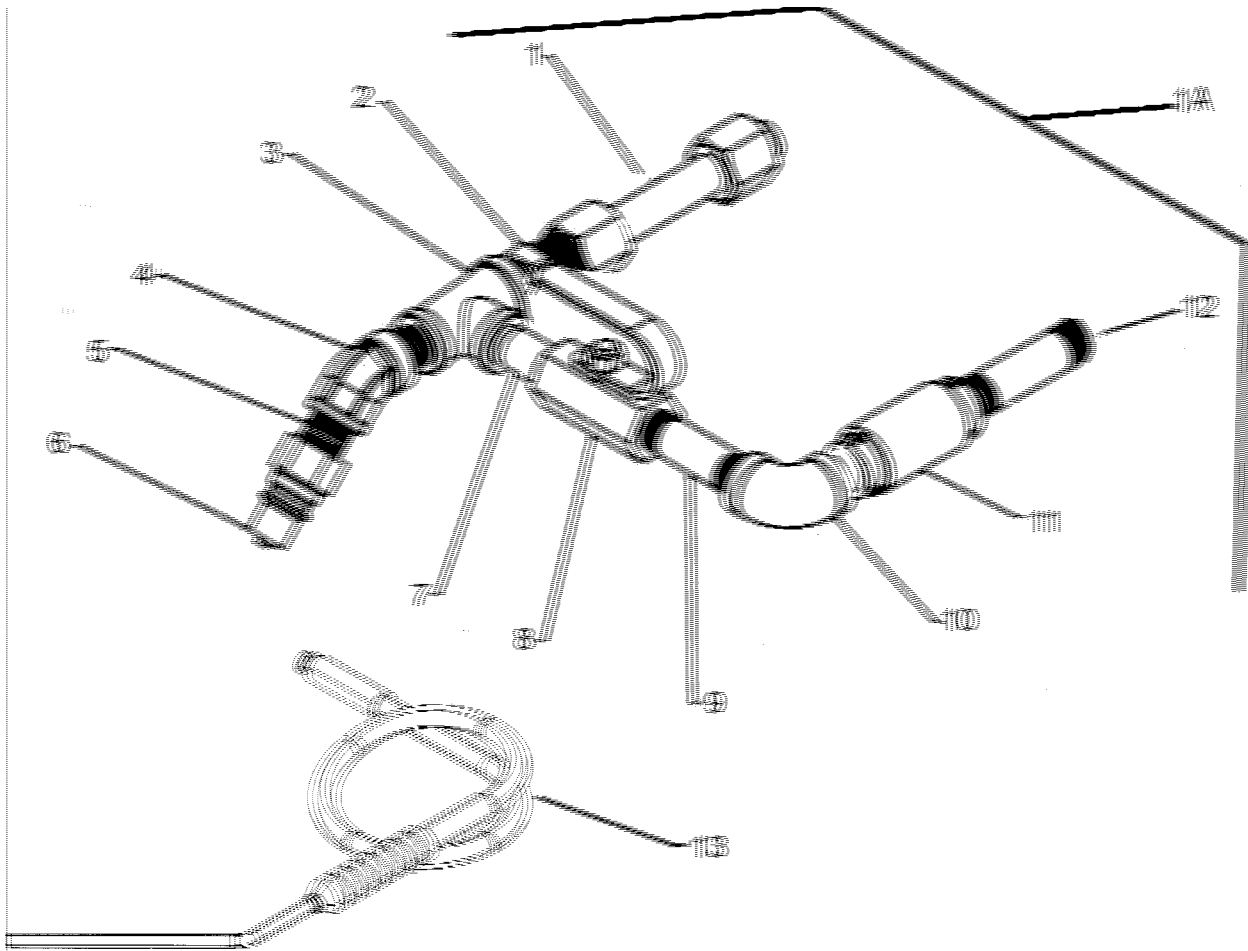

3-12B. OPTIONAL RINSE HOSE ATTACHMENTS (SN: LG013JC & ABOVE)

Figure & Item No.	Part No.	Description	Qty.
3-12B	14780	OPTIONAL RINSE HOSE ATTACHMENTS	
1A	66450	KIT - PFE590-RINSE HOSE ATTACH	1
1	66450	ASSY -PUMP TO VALVE TUBE - 591	1
2	FP01-170	CONNECTOR - STRAIGHT MALE 3/4 NPT	1
3	FP01-171	TEE - 3/8 X 3/4 X 3/4 B. I.	1
4	FP01-172	ELBOW - 45 STREET 3/8 NPT B. I.	1
5	FP02-024	NIPPLE - 3/8 NPT - CLOSE B. I.	1
6	17334	RINSE HOSE DISCONNECT - MALE	1
7	FP02-044	NIPPLE - 3/4 X 2 LG B. I.	1
8	23430	VALVE - 3/4 INLET - E34X	1
9	16282	NIPPLE - 3/4 X CLOSE	1
10	FP01-100	ELBOW - STREET 3/4 NPT B. I.	1
11	21800	VALVE - 3/4 CHECK	1
12	FP02-021	NIPPLE - 3/4 NPT X 3 IN LG B. I.	1
13	03003	DETACHABLE HOSE ASSEMBLY	1

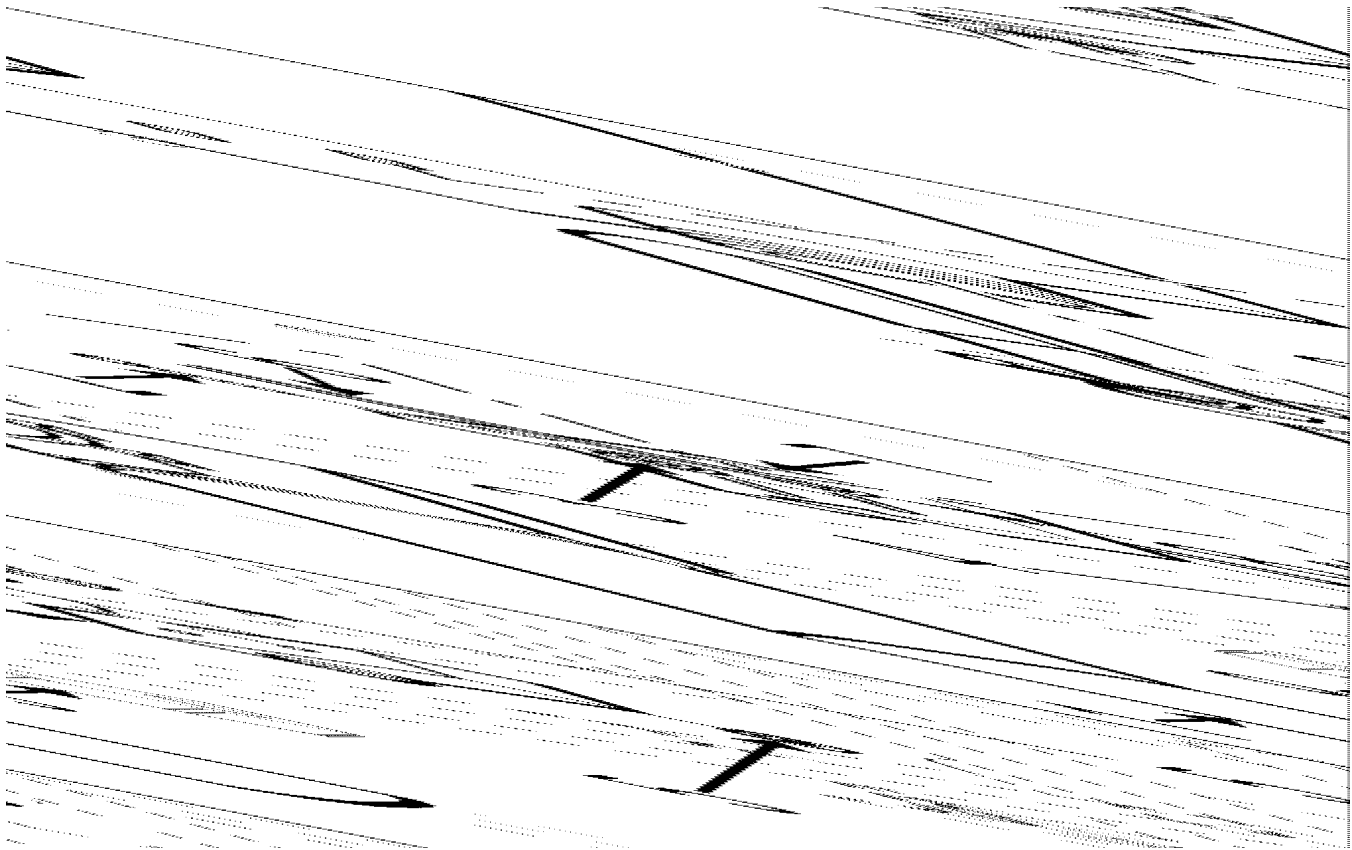
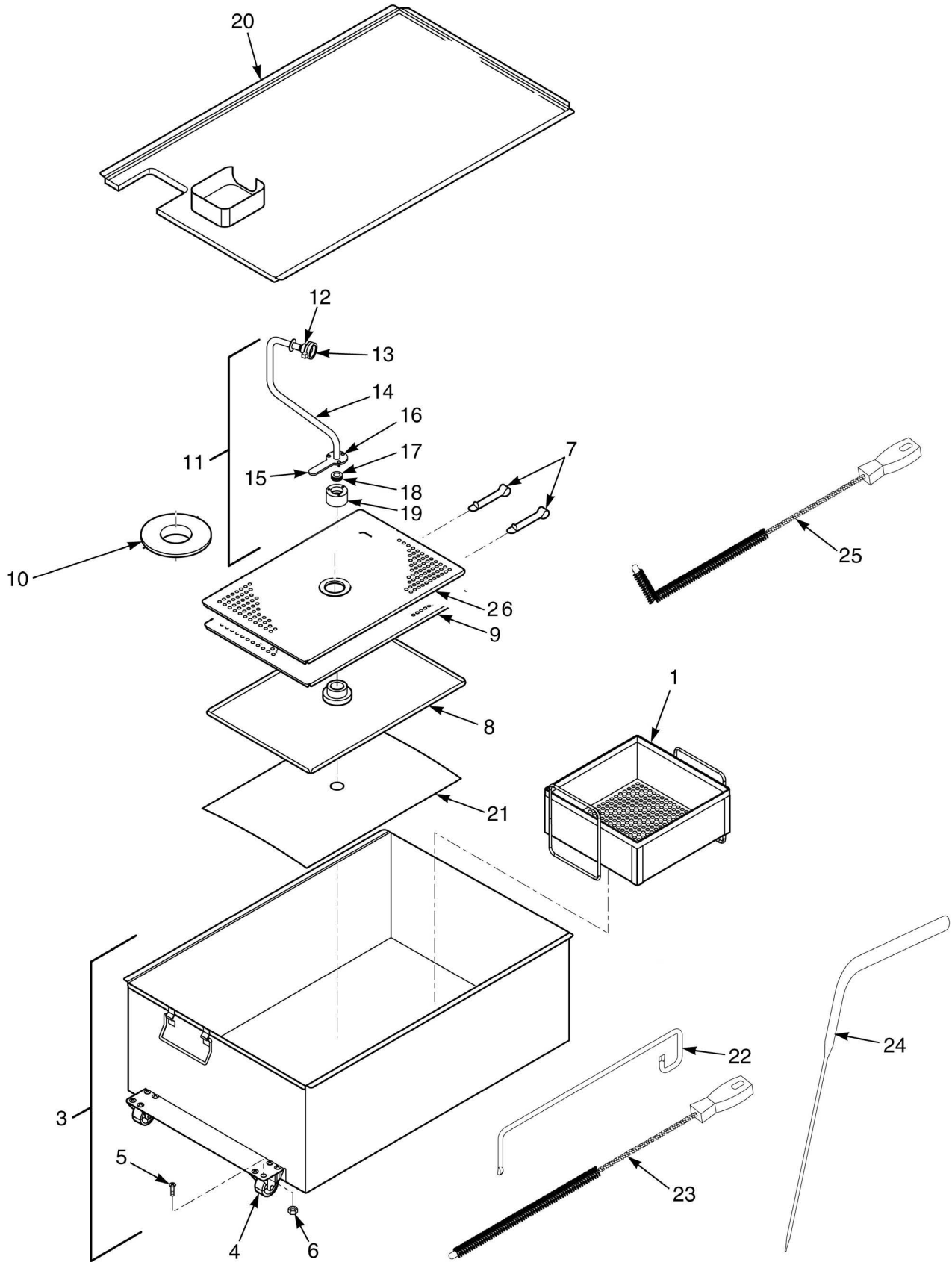

Figure & Item No.	Part No.	Description	Qty.
3-13		DRAIN VALVE & DRAIN SWITCH ASSEMBLIES	
1	66520	DRAIN VALVE ASSY (SN: LG012JC & BELOW)	1
1	66553	DRAIN VALVE ASSY (SN: LG013JC & ABOVE)	1
2	SC01-058	SCREW #6-32 X 1 PH. PAN HD.	2
3	WA01-006	WASHER #6 TYPE A.....	2
√ 4	54228	DRAIN SWITCH W/BOOT.....	1
5	NS02-005	NUT #6-32 HEX.....	2
6	52519	CORD ASSY - DRAIN INTERLOCK.....	1
7	65522	BRACKET, SWITCH (SN: AC0403050 & below).....	1
7	67619	BRACKET, SWITCH (SN: AC0403051 & above).....	1
8	EF02-017	STRAIN RELIEF.....	2
9	67617	BRACKET - MICROSWITCH TRIGGERING.....	1
10*	76579	PLATE - D/I SWITCH COVER.....	1

√ recommended part

* not shown



3-14. DRAIN PAN & FILTER ASSEMBLY

Figure & Item No.	Part No.	Description	Qty.
3-14		DRAIN PAN & FILTER ASSEMBLY	
1	52194	CRUMB CATCHER (OPTIONAL)	1
2*	03203	CRUMB CATCHER BASKET W/HANDLE	1
		(OPTIONAL) (FITS INSIDE FRYPOT)	
2*	21471	CRUMB CATCHER BASKET ASSEMBLY	1
2*	24491	HANDLE - CRUMB BASKET	1
3	52496	FILTER DRAIN PAN ASSEMBLY	1
4	52487	CASTER	2
5	SC01-009	SCREW 1/4-20 X 1/2	8
6	NS02-002	NUT 1/4-20	8
7	17505	FILTER CLIPS	2
8	17503(use 14674)	BOTTOM FILTER SCREEN	1
		(SN:AC0503055 AND BELOW)	
8	65447	BOTTOM FILTER SCREEN-SS	1
		(SN: AC0503056 AND ABOVE)	
9	17502(use 14674)	TOP FILTER SCREEN	1
		(SN:AC0503055 AND BELOW)	
10	36305	WASHER & STANDPIPE	1
11	24212	STANDPIPE ASSEMBLY	1
		(SN:AC0503055 AND BELOW)	
11	14658	KIT, 8 HEAD PICK-UP TUBE	1
		(SN AC0503056 & ABOVE)	
√ 12	17431(use 69289)	UNION - MALE FITTING	1
√ 13	17432(use 69289)	UNION - HANDLE FITTING	1
14	24211	WELDMENT, FILTER TUBE AND WASHER.....	1
15	23740	HANDLE, STANDPIPE 8 HEAD.....	1
16	SC01-245	SCREW 10-32 X 1/2	3
17	23804	INSERT, FILTER NUT	1
18	OR01-007	O-RING, FILTER NUT INSERT	1
19	23803	FILTER NUT (SN:AC0503055 AND BELOW)	1
19	66535	FILTER NUT (SN AC0503056 & ABOVE)	1
20	62082	FILTER DRAIN PAN COVER ASSEMBLY	1
√ 21	12102	FILTER ENVELOPE PAPER (100 PER CARTON)	1
22	65776	ROD - LONG CLEAN OUT	1
√ 23	35771	BRUSH	1
24	35310	STIRRER	1
√ 25	12126	BLACK L-BRUSH.....	1
26	65211	CRUMB CATCHER - SS	1

√ recommended part
* not shown

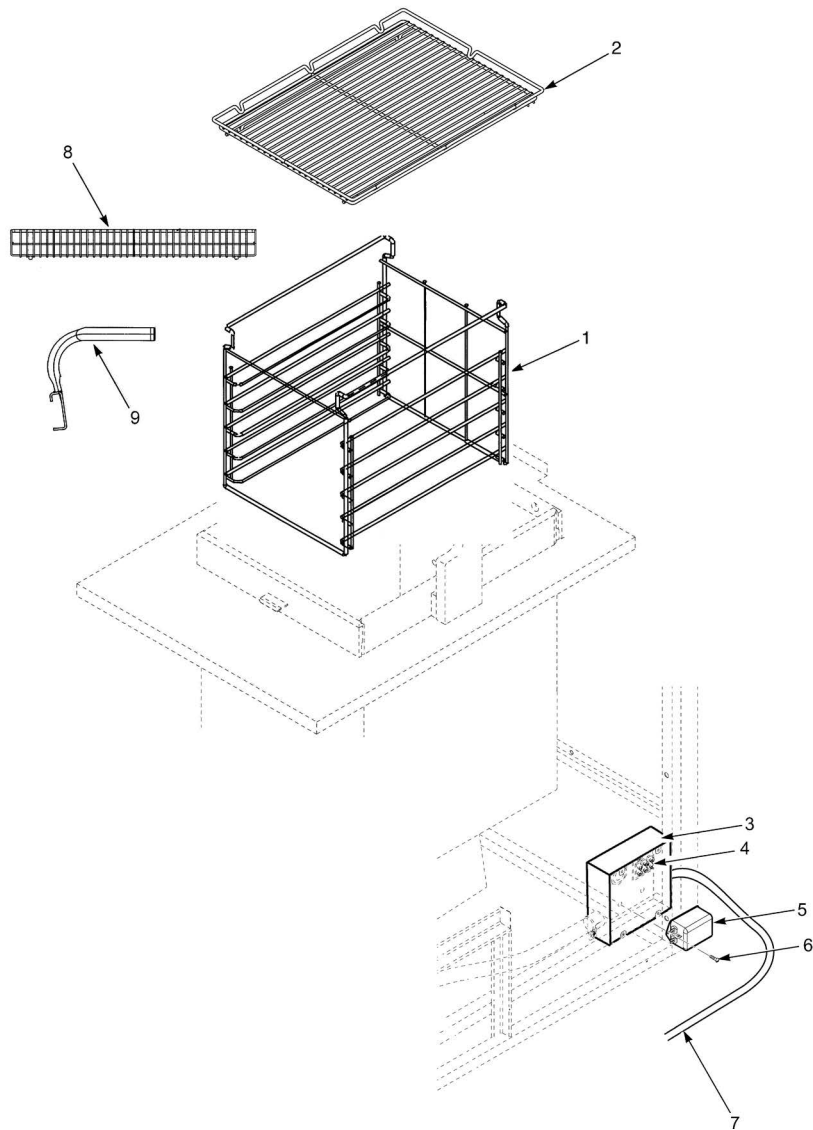

Figure & Item No.	Part No.	Description	Qty.
3-15		CARRIER, RACKS & JUNCTION BOX ASSY	
1	35194	CARRIER ASSY	1
2	44782	RACK HALF SIZE – 8 HEAD FRYER.....	1
3	62126	JUNCTION BOX ASSY.....	1
3	62127	JUNCTION BOX ASSY - CE	1
4	65427	ASSY - 5-POLE TERMINAL BLOCK - CE	1
√ 5	51057	ASSY - EMC FILTER - CE.....	1
6	SC01-023	SCREW #6-32 X 1/4 PH RHD C	8
7	65180	ASSY - MAIN POWER CORD	1
7	65181	CORD - 291/591 POWER	1
*	58146	PLUG-90, 60A, 3PH, 250V, #15-60P	1
8	36404	WIRE BASKET - GM 8 HEAD.....	4
9	36374	ASSY - BASKET HANDLE WELD.....	1
10*	19923	TRANSFORMER - LARGE - 480 VOLT.....	1
11*	70824	ASSY - CE GROUNDING LUG.....	1

√ recommended part/* not shown

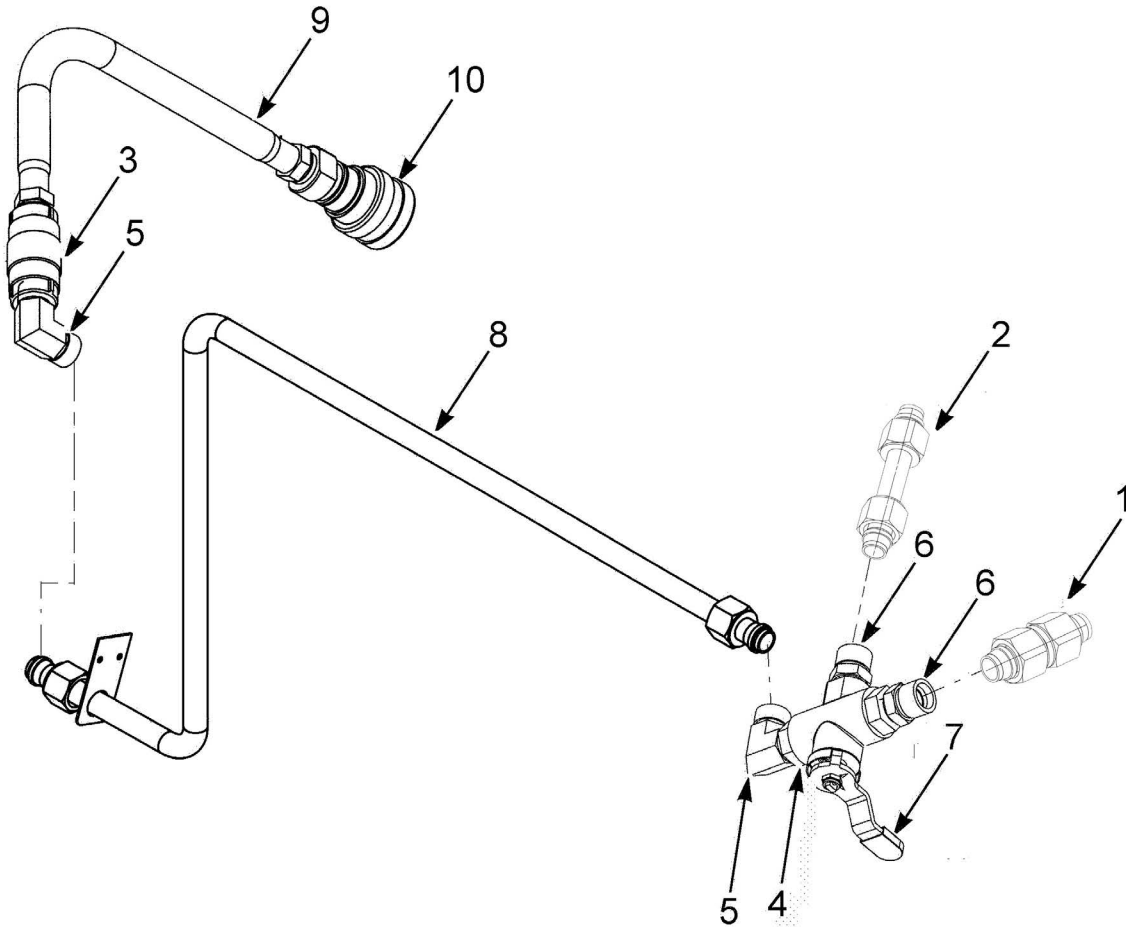

Figure & Item No.	Part No.	Description	Qty.
3-16	14638	OPTIONAL DIRECT-CONNECT KIT	1
		(SN: LG014JC & ABOVE only)	
1	67695	ASSY - TUBE DC POT TO DIVERTER.....	1
2	66450	ASSY - TUBE DC DIVERTER TO POT.....	1
3	21800	VALVE - 3/4 CHECK	1
4	68510	VALVE - 3/4 DIVERTER W/O HANDLE	1
5	FP01-169	CON - 90 MALE 3/4 TUBE 3/4 NPT	2
6	FP01-170	CON - STR MALE 3/4 NPT	1
7	68126	HANDLE - 8 HEAD DIRECT CONNECT	1
8	67692	ASSY - DIRECT CONN TUBE 8 HEAD	1
9	21753	HOSE - SHORTENING DISCARD	1
10	21612	DISCONNECT - FEMALE	1