



HENNY PENNY[®]

Engineered to Last

**Henny Penny
Pressure Fryer
Model PFG-690**

TECHNICAL MANUAL

NOTICE

This manual should be retained in a convenient location for future reference.

A wiring diagram for this appliance is located on the rear shroud cover of the control panel.

Post in a prominent location, instructions to be followed if user smells gas. This information should be obtained by consulting the local gas supplier.

Do not obstruct the flow of combustion and ventilation air. Adequate clearance must be left all around appliance for sufficient air to the combustion chamber.

The Model PFG-690 pressure fryer is equipped with a continuous pilot. But fryer cannot be operated without electric power. Fryer will automatically return to normal operation when power is restored.

CAUTION

Keep appliance area free and clear from combustibles.



Improper installation, adjustment, alteration, service or maintenance can cause property damage, injury or death. Read the installation, operating and maintenance instructions thoroughly before installing or servicing this equipment.



DO NOT STORE OR USE GASOLINE OR OTHER FLAMMABLE VAPORS AND LIQUIDS IN THE VICINITY OF THIS OR ANY OTHER APPLIANCE. FIRE OR EXPLOSION COULD RESULT.

HENNY PENNY 8 HEAD GAS PRESSURE FRYER SPECIFICATIONS

Height	61" (155 cm)
Width	24" (61 cm)
Depth	41¾" (106 cm)
Floor Space	Approximately 7 sq. ft. (0.65 sq. m.)
Pot Capacity	8 Head of chicken (32 lbs.) (14.4 kg.) 130 lbs. shortening (59 kg.)
Electrical	120 VAC, 1 Phase, 50/60 Hz, 10 Amp, 3 Wire Service 240 VAC, 1 Phase, 50/60 Hz, 5 Amp, 3 Wire Service
Heating	Propane or Natural Gas; 100,000 Btu/hr (105.51 MJ/hr)
Pressure	12 psi operating pressure (827 mbar) 14.5 psi safety relief pressure (999 mbar)
Shipping Weight	Approximately 935 lbs. (424 kg.)

NOTICE

A data plate, located on the back shroud behind the lid, gives the information of the type of fryer, serial number, warranty date, and other information pertaining to fryer. Also, the serial number is stamped on the outside of the frypot. See figure below.

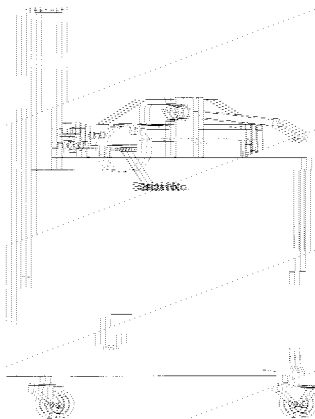

TABLE OF CONTENTS

Section	Page
Section 1. TROUBLESHOOTING.....	1-1
1-1. Introduction	1-1
1-2. Safety.....	1-1
1-3. Troubleshooting.....	1-2
1-4. Error Codes	1-11
 Section 2. MAINTENANCE.....	 2-1
2-1. Introduction	2-1
2-2. Maintenance Hints.....	2-1
2-3. Preventive Maintenance	2-1
2-4. High Temperature Limit Control.....	2-2
2-5. Power/Pump Switch	2-4
2-6. Temperature Probe Replacement.....	2-5
2-7. Complete Control Panel - Henny Penny	2-6
2-8. Pressure Regulation.....	2-7
2-9. Tilting the Lid Upright	2-7
2-10. Reversing the Lid Gasket	2-8
2-11. Lid Counterweight Cables.....	2-9
2-12. Pressure Pad	2-10
2-13. Lid Adjustment.....	2-11
2-14. Clean the Nylatrons.....	2-11
2-15. Solenoid Valve.....	2-12
2-16. Deadweight Valve.....	2-14
2-17. Removal & Cleaning of Safety Relief Valve.....	2-15
2-18. Pressure Gauge	2-16
2-19. Gas Control Valve	2-17
2-20. Blower Assembly	2-19
2-21. Transformer	2-20
2-22. Airflow Switch	2-21
2-23. Drain Microswitch.....	2-22
2-24. Drain Valve and Extension.....	2-23
2-25. Air Valve.....	2-24
2-26. Cleaning the Dilution Box.....	2-25
2-27. Cleaning the Blower Wheel	2-25
2-28. Ignition Modules	2-26
2-29. Ignitor Assembly	2-27
2-30. Flame Sensor Assembly	2-28
2-31. Ignitor and Flame Sensor Adjustment.....	2-28
2-32. Nylatron Strips Replacement	2-29
2-33. Lubricating Lid Rollers	2-30
120 Volt Wiring Diagram (AP0803002 & BELOW)	2-31
120 Volt Wiring Diagram (AP0803003 & ABOVE).....	2-32
220-240 Volt Wiring Diagram (AP0803002 & BELOW).....	2-33
220-240 Volt Wiring Diagram (AP0803003 & ABOVE).....	2-34
230 Volt Wiring Diagram (AP0803002 & BELOW)	2-35
230 Volt Wiring Diagram (AP0803003 & ABOVE).....	2-36

TABLE OF CONTENTS (Continued)

Section	Page
Section 2	MAINTENANCE (Continued)
	230 Volt Ladder Diagram (AP0803002 & BELOW)..... 2-37
	230 Volt Ladder Diagram (AP0803003 & ABOVE)..... 2-38
	100-120 Volt FAST Wiring Diagram (AP0803002 & BELOW) 2-39
	100-120 Volt FAST Wiring Diagram (AP0803003 & ABOVE) 2-40
	230 Volt FAST Wiring Diagram (AP0803002 & BELOW)..... 2-41
	230 Volt FAST Wiring Diagram (AP0803003 & ABOVE) 2-42
	220-240 Volt FAST Wiring Diagram (AP0803002 & BELOW) 2-43
	220-240 Volt FAST Wiring Diagram (AP0803003 & ABOVE) 2-44
Section 3.	PARTS INFORMATION..... 3-1
3-1.	Introduction 3-1
3-2.	Genuine Parts 3-1
3-3.	When Ordering Parts..... 3-1
3-4.	Prices 3-1
3-5.	Delivery 3-1
3-6.	Warranty 3-1
3-7.	Recommended Spare Parts for Distributors 3-2

SECTION 1. TROUBLESHOOTING

1-1. INTRODUCTION

This section provides troubleshooting information in the form of an easy-to-read table.

If a problem occurs during the first operation of a new fryer, recheck the installation per the Installation section of the Operator's Manual.

Before troubleshooting, always recheck the operation procedures per section 3 of the Operator's Manual.

1-2. SAFETY

Where information is of particular importance or safety related, the words DANGER, WARNING, CAUTION, and NOTICE are used. Their usage is described below.



SAFETY ALERT SYMBOL is used with DANGER, WARNING, or CAUTION which indicates a personal injury type hazard.



NOTICE is used to highlight especially important information.



CAUTION used without the safety alert symbol indicates a potentially hazardous situation which, if not avoided, may result in property damage.



CAUTION indicates a potentially hazardous situation which, if not avoided, may result in minor or moderate injury.



WARNING indicates a potentially hazardous situation which, if not avoided, could result in death or serious injury.



DANGER INDICATES AN IMMINENTLY HAZARDOUS SITUATION WHICH, IF NOT AVOIDED, WILL RESULT IN DEATH OR SERIOUS INJURY.

1-3. TROUBLESHOOTING

To isolate a malfunction, proceed as follows:

1. Clearly define the problem (or symptom) and when it occurs.
2. Locate the problem in the Troubleshooting table.
3. Review all possible causes. Then, one at a time, work through the list of corrections until the problem is solved.
4. Refer to the maintenance procedures in the Maintenance section to safely and properly make the checkout and repair needed.



If maintenance procedures are not followed correctly, injuries and/or property damage could result.

1-3. TROUBLESHOOTING

(Continued)

Problem	Cause	Correction
COOKING SECTION		
Product Color Not Correct:		
A. Too Dark	<ul style="list-style-type: none"> • Temperature too high • Faulty temperature probe • Shortening too old • Shortening too dark • Breeding product too far in advance 	<ul style="list-style-type: none"> • Check temperature setting in the program mode; see Programming section of Operator's Manual • Remove and replace temperature probe • Change shortening • Filter shortening • Change shortening • Bread product closer to actual frying period
B. Too Light	<ul style="list-style-type: none"> • Temperature too low • Fryer incorrect preheat • Slow fryer heat-up/recovery • Wrong cook button pushed 	<ul style="list-style-type: none"> • Check temperature setting • Remove and replace temperature probe • Allow proper preheat time • Low gas pressure; have gas pressure checked going to burners • Be sure to select the correct amount of product to be cooked
C. Product Greasy	<ul style="list-style-type: none"> • Shortening old • Temperature too low • Faulty temperature probe • Frypot overloaded • Product not removed from frypot immediately after depressurization 	<ul style="list-style-type: none"> • Replace shortening • Check temperature setting • Temperature not recovered when product was dropped in frypot • Remove and replace defective temperature probe • Reduce cooking load • Remove product from frypot immediately after depressurization

1-3. TROUBLESHOOTING
(Continued)

Problem	Cause	Correction
COOKING SECTION (Continued)		
D. Spotted Product	<ul style="list-style-type: none"> • Improper separation of the product • Breading not uniform on the product • Burned breading particles on product • Product sticking together 	<ul style="list-style-type: none"> • Load product into basket properly • Sift breading regularly • Separate product during breading • Filter the shortening more frequently • Separate product prior to pressure cooking
E. Dryness of Product	<ul style="list-style-type: none"> • Moisture loss prior to cooking • Overcooking the product • Low operating pressure • Wrong cook button pushed 	<ul style="list-style-type: none"> • Use fresh products • Reduce cooking time • Reduce cooking temperature • Check pressure gauge reading, check for pressure leaks • Be sure to select the correct amount of product to be cooked
Product Flavor (Taste): A. Salty Taste B. Burned Taste C. Bland Taste	<ul style="list-style-type: none"> • Breading mixture is too salty • Incorrect choice of breading • Burned shortening flavor • Frypot not properly cleaned • Raw product not fresh • Breading mixture incorrect for product (spice content too low) • Cooking temperature too high (spice flavors lost) 	<ul style="list-style-type: none"> • Sift breading after each use • Incorrect breading mixture • Discard old breading • Use breading designed for the desired product • Replace shortening • Drain and clean frypot • Use fresh raw product • Use breading designed for desired product • Check temperature

1-3. TROUBLESHOOTING
(Continued)

Problem	Cause	Correction
COOKING SECTION (Continued)		
D. Rancid Taste	<ul style="list-style-type: none"> • Shortening too old • Infrequent filtering • Non-compatible products cooked within the same shortening • Raw product not fresh 	<ul style="list-style-type: none"> • Replace shortening and follow recommended care and use of shortening • Replace shortening and follow recommended care and use of shortening • Replace shortening • Use compatible products and follow recommended care and use of shortening • Use fresh product
General: A. Meat Separation From Bone	<ul style="list-style-type: none"> • Incorrect meat cut • Overcooking • Product not fresh 	<ul style="list-style-type: none"> • Use correct meat cutting procedures • Check cooking time • Use fresh product
B. Bone Color Not Proper	<ul style="list-style-type: none"> • Using frozen product (black bone) • Improper processing of product (black bone) • Product not thoroughly cooked (red bone) 	<ul style="list-style-type: none"> • Use fresh product • Use proper processing procedure for product • Check cooking time • Check cooking temperature
C. Breading Falls Off	<ul style="list-style-type: none"> • Incorrect breading procedures • Product partially frozen 	<ul style="list-style-type: none"> • Use correct breading procedure • Thoroughly thaw the product before breading
D. Product Sticking Together	<ul style="list-style-type: none"> • Product breaded too long prior to cooking • Improper loading procedure • Wrong cook button pushed 	<ul style="list-style-type: none"> • Refer to breading and frying instructions • Properly load product per loading procedures • Be sure to select the correct amount of product to be cooked

1-3. TROUBLESHOOTING

(Continued)

Problem	Cause	Correction
POWER SECTION		
<p>With switch in POWER position, the fryer is completely inoperative (NO POWER)</p>	<ul style="list-style-type: none"> • Open circuit 	<ul style="list-style-type: none"> • Check to see that unit is plugged in • Check the breaker or fuse at supply box • Check voltage at wall receptacle • Check MAIN POWER switch; replace if defective • Check cord and plug
PRESSURE SECTION		
<p>Pressure will not exhaust at end of cook cycle</p>	<ul style="list-style-type: none"> • Exhaust line from solenoid valve to exhaust tank clogged • Solenoid valve clogged 	<ul style="list-style-type: none"> • Turn unit off and allow fryer to cool to release pressure from frypot; clean all pressure lines, exhaust stacks, and exhaust tank • Check and clean solenoid valve per maintenance section on solenoid valve
<p>Operating pressure too high</p>	<ul style="list-style-type: none"> • Dead weight clogged • Exhaust line to stack clogged 	<ul style="list-style-type: none"> • Turn unit off and allow fryer to cool to release pressure from frypot; remove deadweight and clean • Clean exhaust line to stack



DO NOT OPERATE UNIT IF HIGH-PRESSURE CONDITIONS EXIST; SEVERE INJURIES AND BURNS WILL RESULT. PLACE POWER/PUMP SWITCH IN THE OFF POSITION IMMEDIATELY. RELEASE THE PRESSURE BY ALLOWING UNIT TO COOL. THE PRESSURE WILL THEN DROP. DO NOT RESUME USE OF UNIT UNTIL CAUSE OF HIGH PRESSURE HAS BEEN FOUND AND CORRECTED.

1-3. TROUBLESHOOTING

(Continued)

Problem	Cause	Correction
PRESSURE SECTION (Continued)		
Pressure does not build	<ul style="list-style-type: none"> • Not enough product in fryer or product not fresh • Metal shipping spacer not removed from deadweight • Lid open or not latched • Solenoid valve leaking or not closing • Deadweight valve leaking • Pressure not programmed • Lid gasket leaking • Safety relief valve leaking • Pressure pad broken or crushed 	<ul style="list-style-type: none"> • Place proper quantity of fresh product within frypot to generate steam • Remove shipping spacer; see Unpacking section of Operator’s Manual • Close and latch lid • Check or clean solenoid valve per maintenance section on the solenoid valve • Repair per maintenance section on deadweight valve • Check programming • Reverse gasket or lid needs adjusted; see sections 2-10 & 2-13 • Check and replace if necessary per maintenance section on the safety relief valve • Replace pressure pads

1-3. TROUBLESHOOTING
(Continued)

Problem	Cause	Correction
HEATING OF SHORTENING SECTION		
Shortening will not heat	<ul style="list-style-type: none"> • Gas valve knob turned to the OFF position • Blown fuse or tripped circuit breaker at supply box or control panel • Blown fuse in PC board • Faulty Power/Pump switch • Faulty cord and plug • Faulty drain switch • Faulty PC Board • Faulty high limit control switch • Drain valve open • Possible faulty gas control valve • Possible faulty temperature probe • Bad spark ignitor • Low air pressure • Faulty ignitor module • Spark ignitor or flame sensor out of adjustment 	<ul style="list-style-type: none"> • Make sure the gas valve knob is turned to the ON position • Reset breaker or replace fuse • Replace glass fuse in board • Check Power/Pump switch per maintenance section on the Power/Pump switch • Check cord and plug and power at wall receptacle • Check drain switch per maintenance section on drain switches • Remove and replace control panel • Check high limit control switch per maintenance section on the high limit • Close drain valve • With power removed from fryer, check across electrical leads of gas control valve with multimeter, and gas valve in ON position • Replace temperature probe • Replace spark ignitor • Clean or replace blower • Replace air pressure switch • Replace module • The spark ignitor must be 1/8 inch from the pilot hood, and 1/4 inch from the flame sensor

1-3. TROUBLESHOOTING
(Continued)

Problem	Cause	Correction
HEATING OF SHORTENING SECTION (Continued)		
Heating of shortening too slow	<ul style="list-style-type: none"> • Supply line too small - low gas volume • Improper ventilation system • Burner out of adjustment 	<ul style="list-style-type: none"> • Increase supply line size; refer to installation instructions • Refer to installation instructions • Observe burners • Check gas pressure • Clean dilution box; refer to section 2-25 • Clean blower wheel; refer to section 2-26
Shortening overheating	<ul style="list-style-type: none"> • Programming wrong • Faulty PC Board • Faulty temperature probe 	<ul style="list-style-type: none"> • Check temperature setting in the program mode • Remove and replace control panel • Remove and replace temperature probe

1-3. TROUBLESHOOTING
(Continued)

Problem	Cause	Correction
SHORTENING FOAMING/DRAINING SECTION		
Foaming or boiling over of shortening	<ul style="list-style-type: none"> • Water in shortening • Condensation line stopped up • Improper or bad shortening • Improper filtering • Cold zone full of cracklings • Improper rinsing after cleaning the fryer 	<ul style="list-style-type: none"> • At end of a cook cycle, drain shortening and clean frypot; add fresh shortening • Remove and clean condensation line • Use recommended shortening • Refer to the procedure covering filtering the shortening • Filter shortening • Clean and neutralize the frypot; rinse with vinegar to remove the alkaline, then rinse with hot water, and dry frypot
Shortening will not drain from frypot	<ul style="list-style-type: none"> • Drain valve clogged with crumbs 	<ul style="list-style-type: none"> • Open valve, push cleaning rod through drain opening from inside of frypot
Shortening leaking through drain valve	<ul style="list-style-type: none"> • Obstruction in drain • Faulty drain valve 	<ul style="list-style-type: none"> • Remove obstruction • Replace drain valve

1-4. ERROR CODES

In the event of a control system failure, the digital display shows an error message. These messages are coded: “E-4”, “E-5”, “E-6”, “E-32”, “E-41” and “E-71”. A constant tone is heard when an error code is displayed, and to silence this tone, press any of the product buttons.

DISPLAY	CAUSE	PANEL BOARD CORRECTION
“E-4”	Control board overheating	Turn switch to OFF position, then turn switch back to ON; if display still shows “E-4”, the board is getting too hot; check for signs of overheating behind the control panel; once panel cools down the controls should return to normal; if “E-4” persists, have control panel replaced
“E-5”	Shortening overheating	Turn switch to OFF position, then back to ON; if display shows “E-5”, the heating circuits and temperature probe should be checked; once the unit cools down, the controls should return to normal; if “E-5” persists, have control panel replaced
“E-6”	Temperature probe failure	Turn switch to OFF position, then back to ON; if the display shows “E-6”, the temperature probe should be checked; once the probe is repaired, or replaced, the controls should return to normal; if “E-6” persists, have control panel replaced
“E-41”	Programming failure	Turn switch to OFF position, then back to ON; if display shows “E-41”, the control should be re-initialized (See Programming Section) if the error code persists, have control panel replaced
“E-71”	Pump motor relay failure or wiring problem	Replace relay if contacts are stuck closed; check wiring on POWER/PUMP switch, or at wall receptacle; L1 and N may be reversed
“E32, CHECK HIGH LIMIT, DRAIN VALVE, VACUUM SWITCH, BLOWER MOTOR	Air pressure switch open; clogged dilution box or faulty blower; open drain switch; open high limit; open vacuum switch	Clean dilution box or replace blower if necessary; have drain switch checked; reset high limit or have high limit checked; check vacuum switch

1-4. ERROR CODES (Continued)

CE Only - Along with error codes from preceding page, CE units have the following self-diagnostic error codes:

DISPLAY	CAUSE	PANEL BOARD CORRECTION
“E-10”	High limit	Allow unit to cool (15-20 minutes), reset the high limit by manually pushing up on red reset button; if high limit does not reset, high limit must be replaced per section 2-4
“E-15”	Drain Switch	Close the drain using drain valve handle; if display still shows “E-15,” check the drain microswitch per section 2-22
“E-20A”	Air Pressure Switch Failure (stuck closed)	Press the Timer button to try the ignition process again; if “E-20A” persists, call Henny Penny’s Service Department
“E-20B”	Draft Fan or Air Pressure (stuck open)	Press the Timer button to try the ignition process again; if “E-20B” persists, call Henny Penny’s Service Department; Switch Failure Number of failures can be seen in Review Usage (pg. 3-24) of Operator’s Manual, then press EXIT COOL
“E-20C”	Left Gas Module Failure	Press the Timer button to try the ignition process again; if “E-20C” persists, call Henny Penny’s Service Department
“E-20D”	Right Module Failure	Press the Timer button to try the ignition process again; if “E-20D” persists, call Henny Penny’s Service Department
“E-20E”	Both Modules Failure	Press the Timer button to try the ignition process again; if “E-20E” persists, call Henny Penny’s Service Department
“E-20F”	Left Module No Flame Sense	Press the Timer button to try the ignition process again; if “E-20F” persists, call Henny Penny’s Service Department
“E-20G”	Right Module No Flame Sense	Press the Timer button to try the ignition process again; if “E-20G” persists, call Henny Penny’s Service Department
“E-20H”	Both Modules No Flame Sense	Press the Timer button to try the ignition process again; if “E-20H” persists, call Henny Penny’s Service Department

SECTION 2. MAINTENANCE

2-1. INTRODUCTION

This section provides checkout and replacement procedures for various parts of the fryer. Before replacing any parts, refer to the Troubleshooting section to aid you in finding the cause of the malfunction.

2-2. MAINTENANCE HINTS

1. A multimeter will help you check the electric components.
2. When the manual refers to the circuit being closed, the multimeter should read zero unless otherwise noted.
3. When the manual refers to the circuit being open, the multimeter should read infinity.



Do not move the fryer with hot shortening in the frypot or drain filter pan. Severe burns can result from splashing hot shortening.

4. Remove weights from frame to easily access rear of fryer.

2-3. PREVENTIVE MAINTENANCE

To ensure a long life of fryers and their components, regular maintenance should be performed. Refer to the chart below.

<u>Frequency</u>	<u>Action</u>
Daily	Clean deadweight assembly cap, weight, and deadweight orifice (see section 2-15)
See KFC's Standards Library	Filtering of shortening
Monthly	Check dilution box, clean as needed (see section 2-25)
Monthly	Clean the Nylatrons (see section 2-14)
Annually	Clean blower wheel (see section 2-26)
Annually	Lubricate lid rollers in back of fryer (see section 2-32)
Annually	Remove and clean safety relief valve (see section 2-16)
See KFC's Standards Library	Cleaning the frypot
Every 90 Days	Reversing lid gasket (see section 2-10)
Annually	Inspect lift Cables

**2-4. HIGH TEMPERATURE
LIMIT CONTROL**



This high temperature control is a safety, manual reset control, which senses the temperature of the shortening. If the shortening temperature exceeds 425°F (218°C), this switch opens and shuts off the heat to the frypot. When the temperature of the shortening drops to a safe operation limit (15-20 minutes), manually reset by pressing the red reset button. The red reset button is located under the control panel, in the front of the fryer. Once reset, the frypot starts heating.

Before replacing a high temperature limit control, check to see that its circuit is closed.

NOTICE

Checkout

The shortening temperature must be below 380°F (193°C) to accurately perform this check.



1. Remove electrical power supplied to the fryer.



To avoid electrical shock or property damage, move the power switch to OFF and disconnect main circuit breaker, or unplug cord at wall receptacle.



2. Remove the control panel.
3. Remove the two nuts securing high limit bracket to the unit, and pull the bracket from the unit.
4. Remove the two screws securing the high limit to bracket, and remove the high limit from the bracket.



5. Remove the two electrical wires from the high temperature limit control.
6. Manually reset the control, then check for continuity between the two terminals after resetting the control. If the circuit is open, replace the control, then continue with this procedure. (If the circuit is closed, the high limit is not defective. Reconnect the two electrical wires.)

**2-4. HIGH TEMPERATURE
LIMIT CONTROL
(Continued)**

Replacement



To avoid electrical shock or property damage, move the power switch to OFF and disconnect main circuit breaker, or unplug cord at wall receptacle.

1. If the tube is broken or cracked, the control will open, shutting off electrical power. The control cannot be reset.
2. Drain shortening from the frypot and discard. A substance in the tube could contaminate the shortening.
3. Remove control panel.
4. Loosen small inside screw nut on capillary tube.
5. Remove capillary bulb from bulb holder inside the frypot.
6. Straighten the capillary tube.
7. Remove larger outside nut that threads into pot wall, and remove defective control from control panel area.
8. Insert new control and replace screws.
9. Uncoil capillary line, starting at capillary tube, and insert through frypot wall.



To avoid electrical shock or other injury, run the capillary line under and away from all electrical power wires and terminals. The tube must NEVER be in such a position where it could accidentally touch the electrical power terminals.

10. Carefully bend the capillary tube as shown in photo and place into bulb brackets.

**2-4. HIGH TEMPERATURE
LIMIT CONTROL
(Continued)**

11. Pull all excess capillary line from the frypot and tighten nut **into** frypot wall.

CAUTION

Be sure capillary bulb of high limit is positioned so it does not interfere with the carrier or get damages when cleaning the frypot.

12. With excess capillary line pulled out, tighten smaller nut.
13. Replace front panel.
14. Refill with shortening.

2-5. POWER/PUMP SWITCH

The Power/Pump switch is a three-way rocker switch with a center OFF position. With the switch in the POWER position, the fryer operates. With the switch in the PUMP position, the filter pump operates, but the unit will not heat.



To avoid electrical shock or property damage, move the power switch to OFF and disconnect main circuit breaker, or unplug cord at wall receptacle.

Checkout

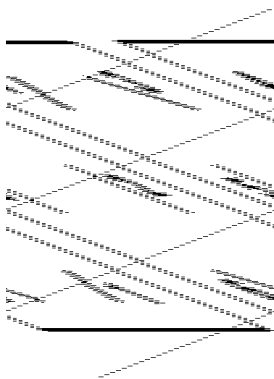

1. Remove Control Panel.
2. Label and remove wires from the switch.
3. “OFF” Position - should be open circuit anywhere on the switch.
4. “Power” Position. Check from: #5 to #6 closed circuit
#1 to #2 closed circuit
5. “Pump” Position. Check from: #4 to #5 closed circuit
#3 to #2 closed circuit

NOTICE

Check across the jumpers on the wires of the Power/Pump switch. These jumpers have resistors and capacitors which may be faulty.

2-5. POWER/PUMP SWITCH

(Continued)

Replacement



1. With control panel removed, and wires off the switch, push in on tabs on the switch to remove from the panel.
2. Replace with new switch, and reconnect wires to switch following the wiring diagram.
3. Replace the control panel.

2-6. TEMPERATURE PROBE REPLACEMENT



Temperature Probe relays the actual shortening temperature to the control. If it becomes disabled, “E-6” will show in the display. Also, if the temperature is out of calibration more than 10°F, or 10°C, the temperature probe should be replaced. An Ohm check can be performed also. See chart at end of this section.

1. Remove electrical power supplied to the fryer.



To avoid electrical shock or property damage, move the power switch to OFF and disconnect main circuit breaker, or unplug cord at wall receptacle.

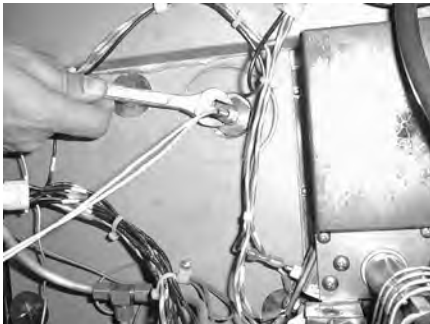

2. Drain the shortening from the frypot.
3. Remove the Control Panel.
4. Using a 1/2” wrench, remove the nut on the compression fitting.
5. Remove the temperature probe from the frypot.

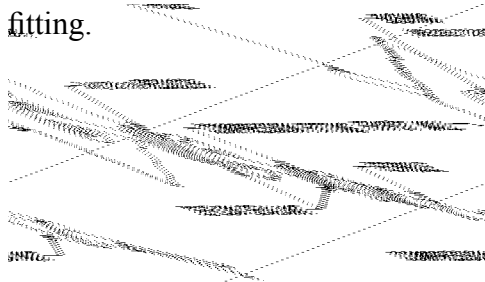

6. Place nut and new ferrule on new temperature probe and insert the temperature probe into the compression fitting until it extends 1/2 inch (1.3 cm) into the frypot. Use the temperature probe gauge provided in the temperature probe kit to ensure proper placement in frypot. See Figures 2-1 and 2-2.

Figure 2-1

2-6. TEMPERATURE PROBE REPLACEMENT (Continued)

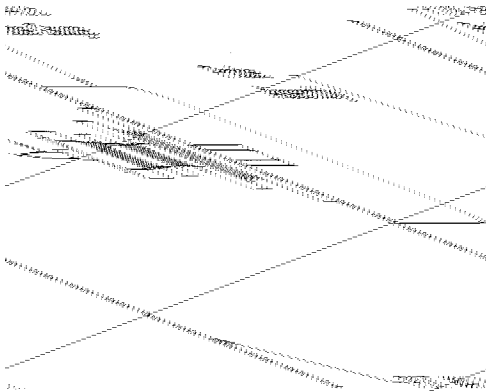

Figure 2-2

7. Tighten hand tight and then a half turn with wrench.

CAUTION

Excess force will damage temperature probe.

8. Connect new temperature probe to PC board and replace Control Panel.
9. Replace shortening.
10. Turn power ON and check out fryer.

Temp. F	Temp. C	Resistance Ohms	Temp. F	Temp. C	Resistance Ohms
50	10.00	1039.02	250	121.11	1464.79
60	15.56	1060.65	260	126.67	1485.71
70	21.11	1082.24	270	132.22	1506.58
80	26.67	1103.80	280	137.78	1527.43
90	32.22	1125.32	290	143.33	1548.23
100	37.78	1146.81	300	148.89	1569.00
110	43.33	1168.26	310	154.44	1589.73
120	48.89	1189.67	320	160.00	1610.43
130	54.44	1211.05	325	162.78	1620.77
140	60.00	1232.39	330	165.56	1631.09
150	65.56	1253.70	340	171.11	1651.72
160	71.11	1274.97	350	176.67	1672.31
170	76.67	1296.20	360	182.22	1692.86
180	82.22	1317.40	365	185.00	1703.13
185	85.00	1327.99	370	187.78	1713.38
190	87.78	1338.57	380	193.33	1733.87
200	93.33	1359.89	390	198.89	1754.31
210	98.89	1380.79	400	204.44	1774.72
212	100.00	1385.00	410	210.00	1795.10
220	104.44	1401.84	420	215.56	1815.44
230	110.00	1422.86	430	221.11	1835.74
240	115.56	1443.85	440	226.67	1856.01

2-7. COMPLETE CONTROL PANEL - HENNY PENNY



Should the Control Panel become inoperative, follow these instructions for replacing the board.

1. Remove electrical power supplied to the fryer.



To avoid electrical shock or property damage, move the power switch to OFF and disconnect main circuit breaker, or unplug cord at wall receptacle.

2. Remove the two screws securing the Control Panel and lift panel up and out.
3. Unplug the connectors going to the Control Board.
4. Install a new Control Panel.

2-8. PRESSURE REGULATION

The Henny Penny Fryer uses pressure as one of the components of the cooking process. Once the lid is sealed to the frypot and the solenoid valve closes, a deadweight valve maintains the correct pressure in the frypot.

The lid has minimal and limited maintenance and repair procedures, which are addressed in the following sections.

The following is a routine maintenance schedule for the lid:

Every 90 days

- Clean and reverse the lid gasket.

Yearly Inspection

- Check lid gasket for splitting and tears - replace if necessary.
- Check pressure pads for wear - rotate if necessary.
- Check cam slide guides - replace if worn or broken.
- Check lid rollers - replace if cracked or damaged.

2-9. TILTING THE LID UPRIGHT

The lid assembly is easily tilted up for cleaning or servicing.

1. Raise the lid and remove racks and carrier.
2. Grasping the lid handle, lift the front of the lid up until it stops in an upright position.



Be sure the metal arm on the left side of the lid is in the vertical position holding the lid upright, or severe injuries could result. (See photo at left.)

2-10. REVERSING THE LID GASKET



The gray rubber gasket surrounding the inside of the lid is designed to be reversed.

Because of heat expansion and the pressure used for the cooking process, the gasket is constantly under extreme stress. Reversing the lid gasket will help to ensure that the fryer will not lose pressure through leakage.

1. Put the lid in the upright position, as previously described.
2. Using a thin blade screwdriver, pry out the gasket at the corners. Remove the gasket.

NOTICE

Check the gasket for any tears or nicks. If the gasket is damaged, it needs to be replaced.



Be sure the metal arm on the left side of the lid is in the vertical position holding the lid upright, or severe injuries could result. (See photo on page 2-7.)

3. Clean the gasket and gasket seat with hot water.
4. Rotate the gasket with the opposite side facing out.

NOTICE

Install the four corners of the lid gasket. Smooth the gasket into place, working from the corners towards the middle of each side.

2-11. LID COUNTERWEIGHT CABLES



The Lid Counterweight in the back of the fryer balances the weight of the lid system to allow easier opening and closing of the lid. The weight has two cables attached to it, and weighs about 150 lbs. (67.5 Kg).

1. Using a 3/8" socket, remove the nuts securing the rear shroud of the fryer and remove the shroud.
2. Using Phillip's-head screwdriver, remove screws securing the top cap and remove cap.
3. Raise the lid.
4. Unscrew the broken cable from the weight assembly and bracket attached to the fryer, and remove broken cable.
5. Screw a 5/16" nut on each end of the new cable.
6. Using a wrench, screw the new cable into the weight assembly until tight.
7. Using a 1/2" wrench, tighten nut (already threaded on the cable) against the weight assembly, securing the cable into weight assembly.
8. Pull the cable over the pulley and down behind the weight assembly.
9. Insert the cable into the hole in bracket and screw a 5/16" nut onto end of the cable. Tighten cable, by screwing the cable through this nut until the weight assembly becomes level.

NOTICE

The safety cable should now have slack in it with the weight assembly level.

10. Tighten the nut against the top of the bracket, securing the cable.
11. Replace top cap and rear shroud; repair is now complete.

2-12. PRESSURE PAD

The pressure pads are plastic strips that the lid cam presses against to seal the lid.



1. Raise the lid.
2. Remove the four screws securing the lid cover and remove cover.



3. Push the lid cam back, off the pressure pads.



4. Using an Allen wrench, remove the large bolt securing pad.



5. Using a Phillips head screw driver, remove the small screw securing the pad and remove the broken pad.

NOTICE

If the pressure pad is worn, but not broken, it can be reversed 180 degrees, and the other end of the pad used.

6. Install new pad in reverse order.

2-13. LID ADJUSTMENT

If steam leaks out from around the lid gasket, the pressure pads could be worn or broken. If the pressure pad is worn, but not broken, it can be reversed 180 degrees, and the other end of the pad used. See Section 2-12.

If steam leaks, check for:

- Pressure pad wear
- Cracked or worn gasket
- Gasket installed improperly
- Fryer operating above 12 psi (827 mbar)



Fryer should be operating at 12 psi (827 mbar), or serious burns could result.

2-14. CLEAN THE NYLATRONS



1. Spray Henny Penny biodegradable, food safe, foaming degreaser (part no. 12226) on Nylatrons.
2. Raise lid up and down several times to spread degreaser.
3. Wipe Nylatrons to remove food soil, grease, and degreaser residue.

2-15. SOLENOID VALVE

This is an electromechanical device that causes pressure to be held in the frypot. The solenoid valve closes at the beginning of the cook cycle and opens automatically at the end of the cook cycle. If this valve should become dirty, or the Teflon seat nicked, pressure will not build up. The gas fryer uses a 120 volt, 60 Hz coil (208/240 volt, 50 Hertz internationally).



To avoid electrical shock or property damage, move the power switch to OFF and disconnect main circuit breaker, or unplug cord at wall receptacle.

Coil Check Procedure

Remove the solenoid wires from the wire nuts which are found behind the control panel. Check across wires.

	RESULTS
208/240 Volt, 60 Hertz	150 Ohms
208/240 Volt, 50 Hertz	230 Ohms
120 Volt, 60 Hertz	50 Ohms

Replacement

1. Remove the right side panel.
2. Remove the Tru-Arc retaining clip on top of coil housing.
3. Remove the cover.
4. If only the coil is to be replaced, disconnect the two coil wires at the wire nuts in the coil housing. Remove the coil, insert new coil, and connect the wires at the wire nuts. Assemble in reverse order of disassembly.



The wires may be connected in any order.



2-15. SOLENOID VALVE
(Continued)



5. If the core-disc assembly is sticking due to buildup of shortening, breading, and food particles, proceed with the following steps:
 - a. Unscrew the solenoid bonnet assembly from solenoid valve body.
 - b. Remove the solenoid bonnet assembly and bonnet gasket.
 - c. Remove the core-disc assembly, core spring retainer, and the core spring.
 - d. Wash all these parts in hot water.

NOTICE

If Teflon seals need to be replaced, proceed to Step 6; otherwise, assemble in reverse order of disassembly. Assemble valve core and blade with smooth side and rounded edge of blade toward the disc spring guide.

6. Repair kit, part no. 17120, is available if a seal must be replaced. If any one seal is defective, replace ALL seals.

NOTICE

Solenoid body must be removed from the fryer for replacement of seals. Continue onto step 7.

7. Loosen the wires on the strain relief and pull the wires through the relief.
8. With the bonnet and core-disc assemblies removed, disconnect the two nut fittings. One connects the solenoid valve to the deadweight, the other is attached to the condensation tank.
9. Remove the elbows from the solenoid valve.
10. Remove the two adapter screws which attach pipe adapter to the solenoid valve body.
11. Remove the disc spring, guide, and Teflon seat.
12. Clean the valve body.

2-15. SOLENOID VALVE
(Continued)

13. Wet O-ring around seat with water and insert O-ring assembly (flat side first) in valve through “IN” side of body. Use an eraser end of pencil and press in the Teflon seal until it snaps into place. BE CAREFUL NOT TO MAR OR NICK THE SEAT.

NOTICE

The smallest nick can cause a pressure leak. Replace all O-ring seals that are in the parts kit and reassemble valve.

14. If the complete valve is to be replaced, follow steps 1, 2, 3, 4, 5, 7, 8 and 9 in this section.

2-16. DEADWEIGHT VALVE



DEADWEIGHT VALVE

DANGER
BURN RISK

DO NOT ATTEMPT TO REMOVE DEADWEIGHT CAP WHILE FRYER IS OPERATING. SEVERE BURNS OR OTHER INJURIES WILL RESULT.

The operating valves are located behind the lid. The valve left of the pressure gauge is a 14-1/2 psi (999 mbar) safety relief valve, and the one on the right is the deadweight valve.

Valves are working properly when the pointer on gauge is in the OPERATING ZONE (green area). The gauge pointer should not normally exceed the operating zone. If the pressure builds to 14-1/2 psi (999 mbar), the safety relief valve will open to release steam pressure from inside frypot.

2-16. DEADWEIGHT VALVE
(Continued)



DO NOT PULL THE RING ON SAFETY RELIEF VALVE. HOT STEAM WILL BE RELEASED AND SEVERE BURNS WILL RESULT.

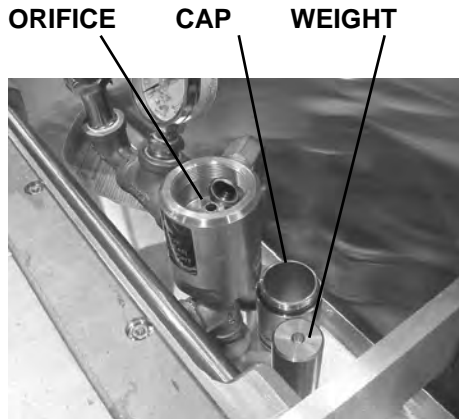

1. AT THE END OF EACH DAY'S USAGE OF THE FRYER, THE DEADWEIGHT VALVE MUST BE CLEANED. The fryer must be OFF and the pressure released. Open the lid and then remove the deadweight valve cap and deadweight.



Failure to clean the deadweight assembly daily could result in the fryer building too much pressure. Severe injuries and burns could result.

2. Wipe both the cap and weight with a soft cloth. Make certain to thoroughly clean inside cap, the weight seat, and around deadweight orifice.
3. Dry the parts and replace immediately to prevent damage or loss.

2-17. REMOVAL & CLEANING
OF SAFETY RELIEF VALVE

The safety relief valve should be cleaned once a year.



DO NOT ATTEMPT TO REMOVE SAFETY RELIEF VALVE WHILE FRYER IS OPERATING, OR SEVERE BURNS OR OTHER INJURIES WILL RESULT.

1. Remove pressure gauge.

**2-17. REMOVAL & CLEANING
OF SAFETY RELIEF VALVE
(Continued)**

2. Use a wrench to loosen the valve from the pipe tee; turn counterclockwise to remove.
3. Clean the inside of the pipe tee with hot water.

NOTICE

Turn the safety relief valve towards the rear of fryer when reinstalling safety relief valve.

4. Immerse the safety relief valve in a soapy water solution for 24 hours. Use a 1 to 1 dilution rate. The valve cannot be disassembled. It is factory preset to open at 14-1/2 psi (999 mbar). If it does not open or close, it must be replaced.



DO NOT DISASSEMBLE OR MODIFY THIS VALVE. TAMPERING WITH THIS VALVE COULD CAUSE SERIOUS INJURIES AND WILL VOID AGENCY APPROVALS AND APPLIANCE WARRANTY.

2-18. PRESSURE GAUGE

Calibration Steps



**ADJUSTING
SCREW**

The pressure gauge can be recalibrated should it be out of adjustment.

1. Remove the rim and glass.
2. If the indication hand shows a pressure or vacuum reading when it should stand at “0”, turn the recalibrator screw in the same direction in which the indicating hand is to be moved until the hand stands at a proper “0” position.
3. Replace the rim and glass.

Cleaning Steps

1. Remove the gauge and check inside the pipe fittings from deadweight body. Make certain fittings are clean and open.
2. Clean and reinstall the gauge.

2-19. GAS CONTROL VALVE

Safety Precautions

The gas control valve sends regulated gas to burners when the controller calls for heat. The control valve can be turned on or off. In ON position, and power switch ON, a spark ignitor lights a standing pilot, and when the control calls for heat, the valve is opened and the burners are ignited.



TO AVOID INJURY, PROPERTY DAMAGE, OR EXPLOSION, BEFORE REPLACING GAS CONTROL VALVE DO THE FOLLOWING:

- **MOVE THE POWER/PUMP SWITCH TO THE "OFF" POSITION.**
- **DISCONNECT MAIN CIRCUIT BREAKER AT THE WALL, OR UNPLUG THE POWER CORD.**
- **TURN OFF THE MAIN GAS SUPPLY TO THE FRYER AND DISCONNECT AND CAP SUPPLY LINE TO FRYER.**

Replacement



NOTICE

A voltage check at the control valve must be taken four (4) seconds after the Power/Pump switch is turned to the Power position.

1. Turn gas knob to the OFF position.
2. Remove cover from control valve.
3. Remove the wires from the control valve.



2-19. GAS CONTROL VALVE
(Continued)



4. Remove left side panel.
5. Remove control panel.
6. Unscrew nut from inlet line from the control valve.

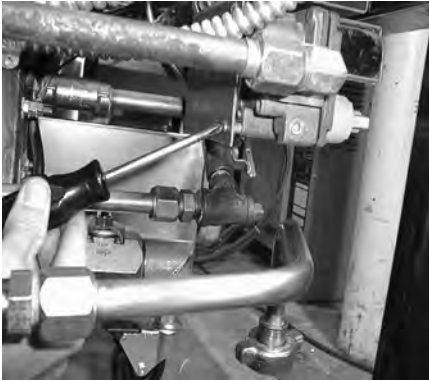

7. Remove the bracket from behind the control valve.



8. Remove pilot light tube from control valve.

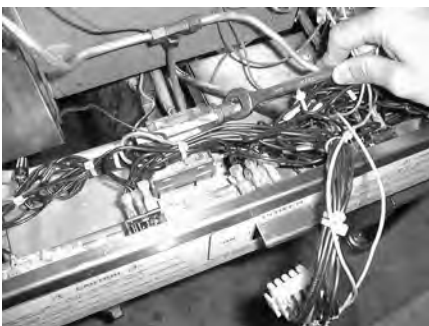

9. Loosen fittings from tee and pull control valve assembly from the unit.
10. Remove the fittings from the defective control valve, and place fittings on new valve.
11. Reassemble in reverse order.

2-20. BLOWER ASSEMBLY

The blower motor circulates air into the burner area to create the correct heat for the fryer. If the blower fails, a sensor will shut the power control valve down.

1. **Make sure unit is off**, and close and lock the lid.



Lid should be in locked down position. Failure to do so could result in personal injury.

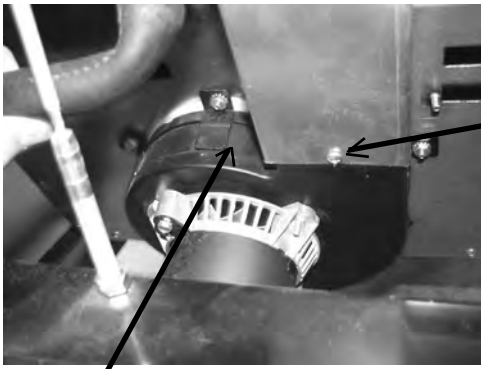

Blower Motor

2. Remove the back shroud of the unit.
3. Using a Phillip's-head screwdriver, remove the screw securing the flue to the blower.
4. Using a 3/8" socket or wrench, remove the 5 nuts securing blower motor and pull motor from unit.
5. Disconnect wires at junction box.
6. Remove the blower from unit.
7. Replace new blower in reverse order of procedures.

2-21. TRANSFORMER

The transformer reduces the voltage down to accommodate those components with low voltage.

1. Remove electrical power supplied to the unit.



To avoid electrical shock or property damage, move the power switch to OFF and disconnect main circuit breaker, or unplug cord at wall receptacle.



2. Remove the control panel.
3. Remove the two screws securing the transformer to the unit and remove transformer.
4. Remove the wires from transformer.



Mark wires before removal to ensure new transformer is wired correctly.

5. Replace with new transformer in reverse order.



2-22. AIRFLOW SWITCH

The airflow switch senses the flow of air coming from the blower. If the airflow is reduced below a set amount, the switch will cut power to the control valve, which shuts the burners down.

Replacement



1. Remove electrical power supplied to the unit.



To avoid electrical shock or property damage, move the power switch to OFF and disconnect main circuit breaker, or unplug cord at wall receptacle.

2. Remove control panel.
3. Remove screws securing air switch to the frame, and remove switch.
3. Pull hose from switch from under fryer.
4. Disconnect wires from switch.

NOTICE

Mark wires before removal to ensure new airflow switch is wired correctly.

5. Install new airflow switch in reverse order.



To avoid property damage, do not tamper with, or disassemble this component. It is set and sealed from the factory and is not to be adjusted.

2-23. DRAIN MICROSWITCH

Upon pulling out on the drain handle, the microswitch should be activated and the unit will not heat, but when the handle is pushed back, the unit should operate properly. The bracket on the microswitch is slotted so it can be adjusted backward or forward.



1. Remove electrical power supplied to the unit.



To avoid electrical shock or property damage, move the power switch to OFF and disconnect main circuit breaker, or unplug cord at wall receptacle.

2. The following check should be made to determine if the drain switch is defective.



- a. Remove bracket from the unit.

- b. Remove wires from the switch.

- c. Check for continuity across the two outside terminals on the drain switch. If circuit is open, the drain switch is bad. The circuit should only be opened by pressing on the actuator of the drain switch.



3. To replace switch, remove switch from the bracket, and install new switch in reverse order.

4. Test to see if the drain valve handle actuates the switch. The gap between the drain switch and the shaft should be no more than 1/8" (3 mm).

HINT: Listen for audible click of switch while pulling drain valve handle.

**2-24. DRAIN VALVE
AND EXTENSION**



The drain valve opens when drain valve handle is pulled out and drains the shortening out of the pot.

1. Using a 3/8" socket, remove the nuts securing the drain switch bracket, and pull the bracket from the studs.
2. Remove the nut securing the drain handle and pull the handle from the drain valve.
3. Using a large adjustable wrench, unscrew drain valve and extension from the unit.
4. Replace the drain valve and extension.
5. Replace the drain switch bracket.
6. Adjust the microswitch to be no more than 1/8" (3 mm) from the shaft of the drain valve.

HINT: Listen for audible click of switch while pulling drain valve handle.

2-25. AIR VALVE

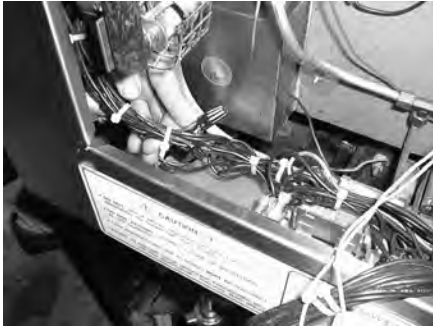

The air valve allows circulation of the shortening in the frypot to keep the shortening at a uniform temperature.

1. Remove electrical power supplied to the unit.



To avoid electrical shock or property damage, move the power switch to OFF and disconnect main circuit breaker, or unplug cord at wall receptacle.

2. Remove the left side panel.
3. Remove the wires from the wire nuts.
4. Disconnect union at the valve.
5. Loosen the nut on the conduit connector and pull coil from conduit.
6. Remove close nipple and female part of union from valve body.
7. Replace with new valve in reverse order.

2-26. CLEANING THE DILUTION BOX

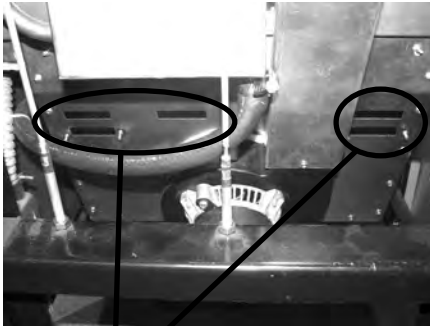

DILUTION SLOTS



2-27. CLEANING THE BLOWER WHEEL

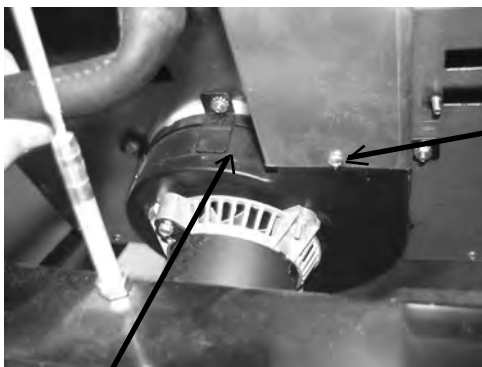

Blower Motor

Clean the dilution box **annually** to ensure the unit operates efficiently and with few failures.

1. **Make sure unit is off**, and close and lock the lid.



Lid should be in locked down position. Failure to do so could result in personal injury.

2. Remove the back shroud of the fryer.
3. Clean dilution box with a cloth or brush. Make sure slots are free of debris. Replace back shroud when finished.



Depending on the breading location and conditions within the kitchen area, the dilution slots may need to be cleaned more often. See example at left:

The blower wheel must be cleaned annually to ensure the unit operates efficiently and without failures.

1. **Make sure unit is off**, and close and lock the lid.



Lid should be in locked down position. Failure to do so could result in personal injury.

2. Remove the back shroud of the unit.
3. Clean the inside of back shroud and the rear of the fryer.
4. Using a Phillip's-head screwdriver, remove the screw securing the flue to the blower.
5. Using a 3/8" socket or wrench, remove the 5 nuts securing blower motor and pull motor from unit.
6. Clean fins of blower wheel, using a brush or flat blade screwdriver. Make sure the fins are clean of any debris.



Depending on breading location and kitchen area conditions, cleaning the blower wheel should be done more often.

2-28. IGNITION MODULES

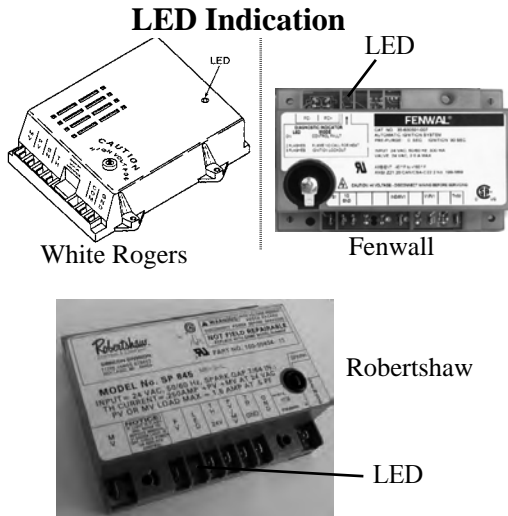

Sends 24 volts to the ignitors and gas control valve.

3 different modules are in the field. The White Rogers and Fenwall modules have a red LED, and the Robertshaw modules have a green LED. These LEDs help to identify a failure.

For White Rogers & Fenwall modules, when the control calls for heat, the LED flashes, then goes out, indicating control is functional. If the LED continues to flash, the module did not sense a pilot flame. If LED stays on continuously, an internal fault has been detected, and the module should be replaced.

For Robertshaw, when the control calls for heat, the LED will be on continuously, indicating the control is functional. If LED flashes, module did not sense a pilot flame. If LED goes out while the control is calling for heat, an internal fault has been detected, and the module should be replaced.

Replacement

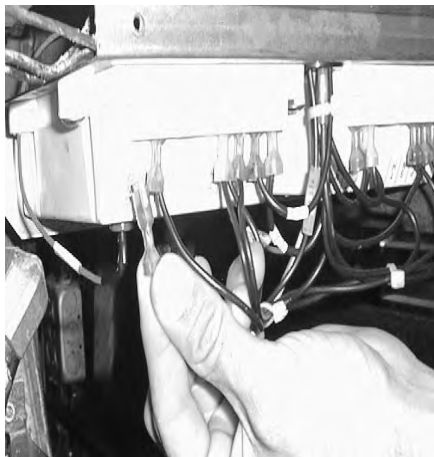

1. Remove electrical power supplied to the unit.



To avoid electrical shock or property damage, move the power switch to OFF and disconnect main circuit breaker, or unplug cord at wall receptacle.

2. Remove the control panel as discussed in section 2-7.
3. Remove the condensation drain pan.
4. Using a Phillips head screwdriver, remove the screws securing the module cover and remove the cover.
5. Label and remove the wires from the module.
6. Using a 3/8" socket and Phillips head screwdriver, remove nuts and screws securing module and remove it from unit.
7. Replace with module in reverse order.

2-29. IGNITOR ASSEMBLY

Replacement

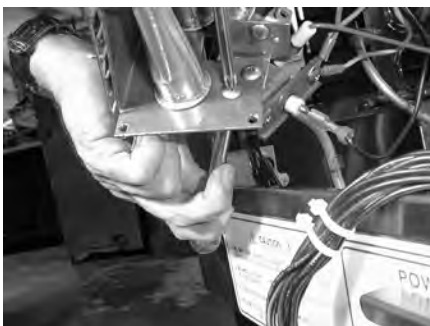
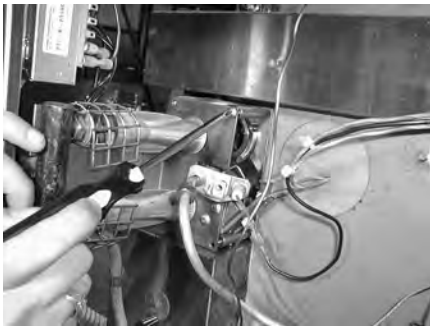

The 690 Model has electronic spark ignition that lights a standing pilot.

1. Remove electrical power supplied to the unit.



To avoid electrical shock or property damage, move the power switch to OFF and disconnect main circuit breaker, or unplug cord at wall receptacle.



TO AVOID INJURY, PROPERTY DAMAGE, OR EXPLOSION, BEFORE REPLACING IGNITOR ASSEMBLY, DO THE FOLLOWING:

- **MOVE THE POWER/PUMP SWITCH TO THE “OFF” POSITION.**
- **DISCONNECT MAIN CIRCUIT BREAKER AT THE WALL, OR UNPLUG THE POWER CORD.**
- **TURN OFF THE MAIN GAS SUPPLY TO THE FRYER AND DISCONNECT AND CAP THE SUPPLY LINE TO FRYER.**

2. Remove the control panel as discussed in section 2-7.
3. Disconnect the 1/4” gas line fitting from the pilot assembly.
4. Follow the wire from the spark ignitor to the module, and remove the wire from the module.
5. Remove the left or right side panel, depending upon which ignitor assembly will be removed.
6. Disconnect gas line (for the left ignitor assembly).
7. Remove the four screws securing burner assembly, and pull the assembly from the unit.
8. Using a Phillips head screwdriver, remove screw securing the ignitor assembly to the burner assembly, and pull the ignitor assembly from the unit.
9. Secure new assembly with the screw previously removed, making sure the assembly is turned to provide a 1/8” gap between the spark ignitor and the hood of pilot assembly.

2-30. FLAME SENSOR ASSEMBLY

Replacement



The flame sensor should glow a bright red when pilot is lit and allows the gas control valve to open. If it does not sense a flame, it will shut the gas control valve down.

1. Remove electrical power supplied to the unit.



To avoid electrical shock or property damage, move the power switch to OFF and disconnect main circuit breaker, or unplug cord at wall receptacle.

2. Remove the control panel as discussed in section 2-7.
3. Pull the wire off the terminal of the flame sensor.
4. Using Phillips head screwdriver, remove the screw securing flame sensor assembly, and remove assembly from the unit.
5. Replace with new assembly in reverse order. Make sure the flame sensor has 1/4" gap between it and the pilot hood.

2-31. IGNITOR AND FLAME SENSOR ADJUSTMENT

For proper function of the ignitor and flame sensor, it is **critical** that they are adjusted properly. The flame rectification, from the flame sensor to the module, should at least be 1.3 micro-amps. See photos.

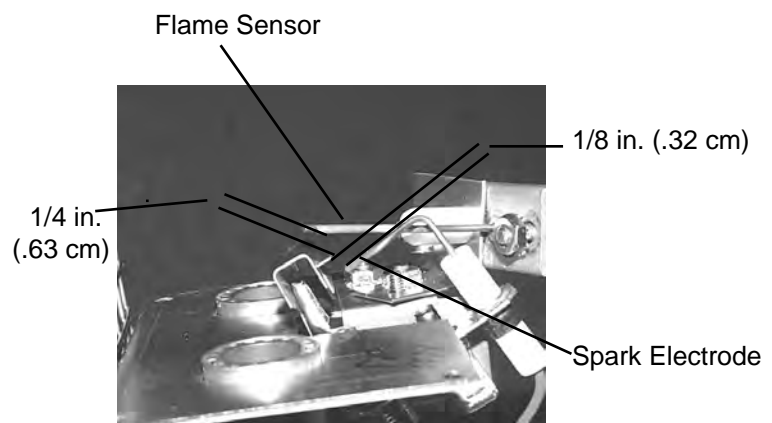
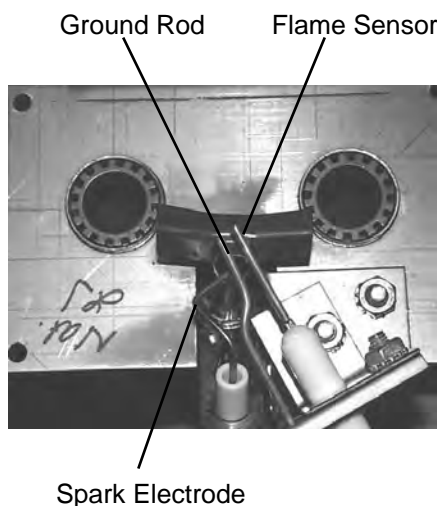

If the burner assembly is removed from the fryer to install and adjust the parts, once the assembly is re-installed, check the spacing of the components again.

2-32. NYLATRON STRIPS REPLACEMENT



1. Raise the lid and remove the retention ring from one end of the lid pin.
2. Slide the lid pin from unit.
3. Lift the lid from unit.



The lid weighs 80 lbs (36 kg). Take care when lifting lid to prevent personal injury.



4. Using a 3/8" socket, remove the nuts securing the rear shroud and remove shroud.
5. Using a Phillip's-head screwdriver, remove the screws securing the top cap and remove top cap.



6. Remove the bolts securing the nylatron strips to the weight assembly and remove strips from weight assembly.
7. Using a Phillip's-head screwdriver, remove the screws securing the front shroud.



8. Unfasten the exhaust hose from the hose clamp.

**2-32. NYLATRON STRIPS
REPLACEMENT (CONTD)**



9. Lift the front shroud up and out, over the arm of the lid.

10. Thread the new nylatron strip through the track in the front shroud.



11. Lining up the holes in the strips, fit the front shroud back over the lid arms.

12. Secure the strips to the weight assembly.

13. Replace back shroud, top cap, and lid, and replacement is complete.

**2-33. LUBRICATING LID
ROLLERS**

The lid rollers, in the back of the fryer, should be lubricated at least once a year, to allow the lid easy movement.



1. Remove the back shroud of the fryer.

2. Using spindle lube, part number 12124, place a small amount of lube on both top and bottom rollers. Make sure to lube both left and right rollers.

3. Clean the inside of back shroud and the back of the fryer.

4. Replace the back shroud.

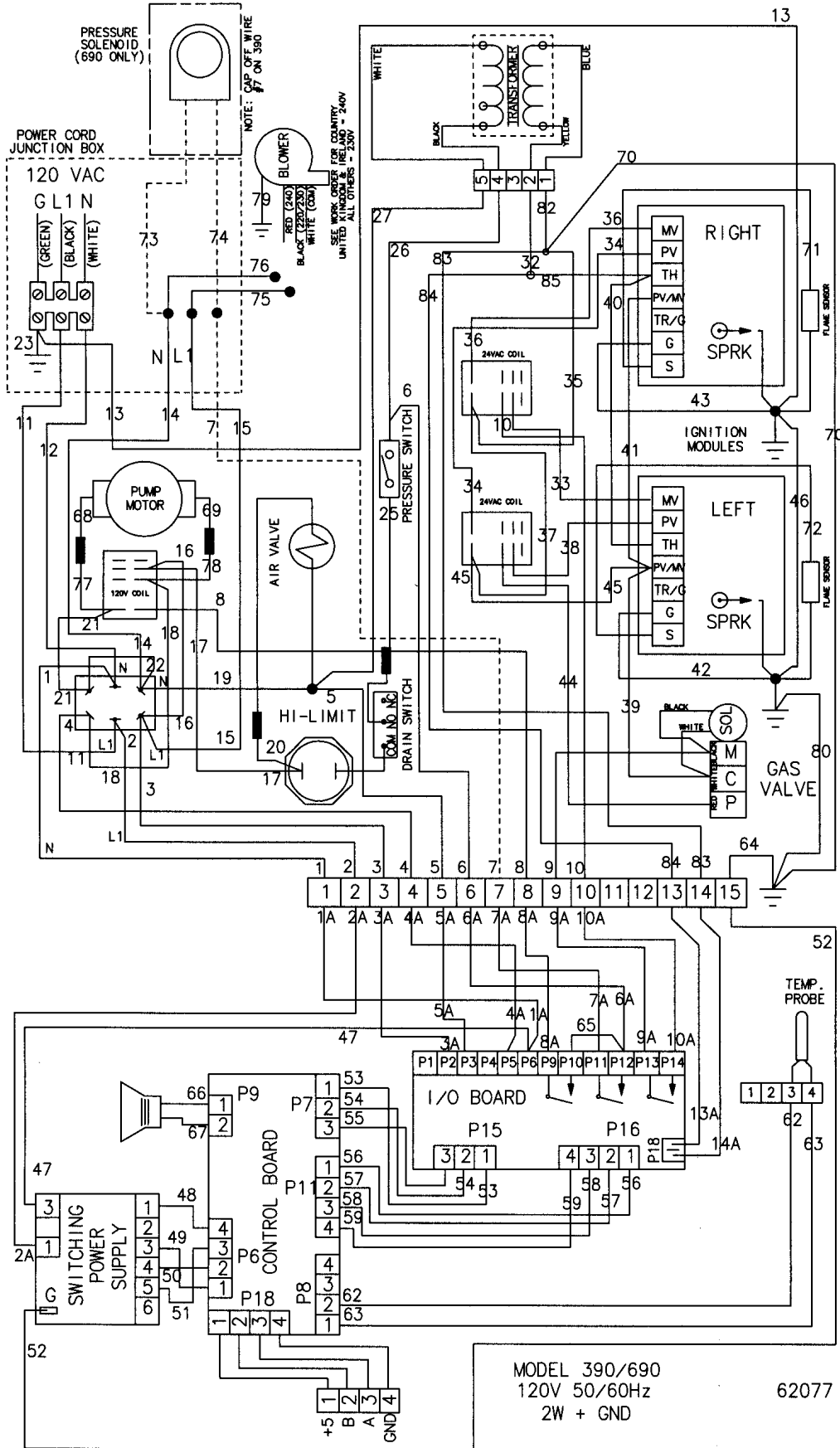

MODEL 390/690
120V 50/60Hz
2W + GND
62077

AP0803002 & below

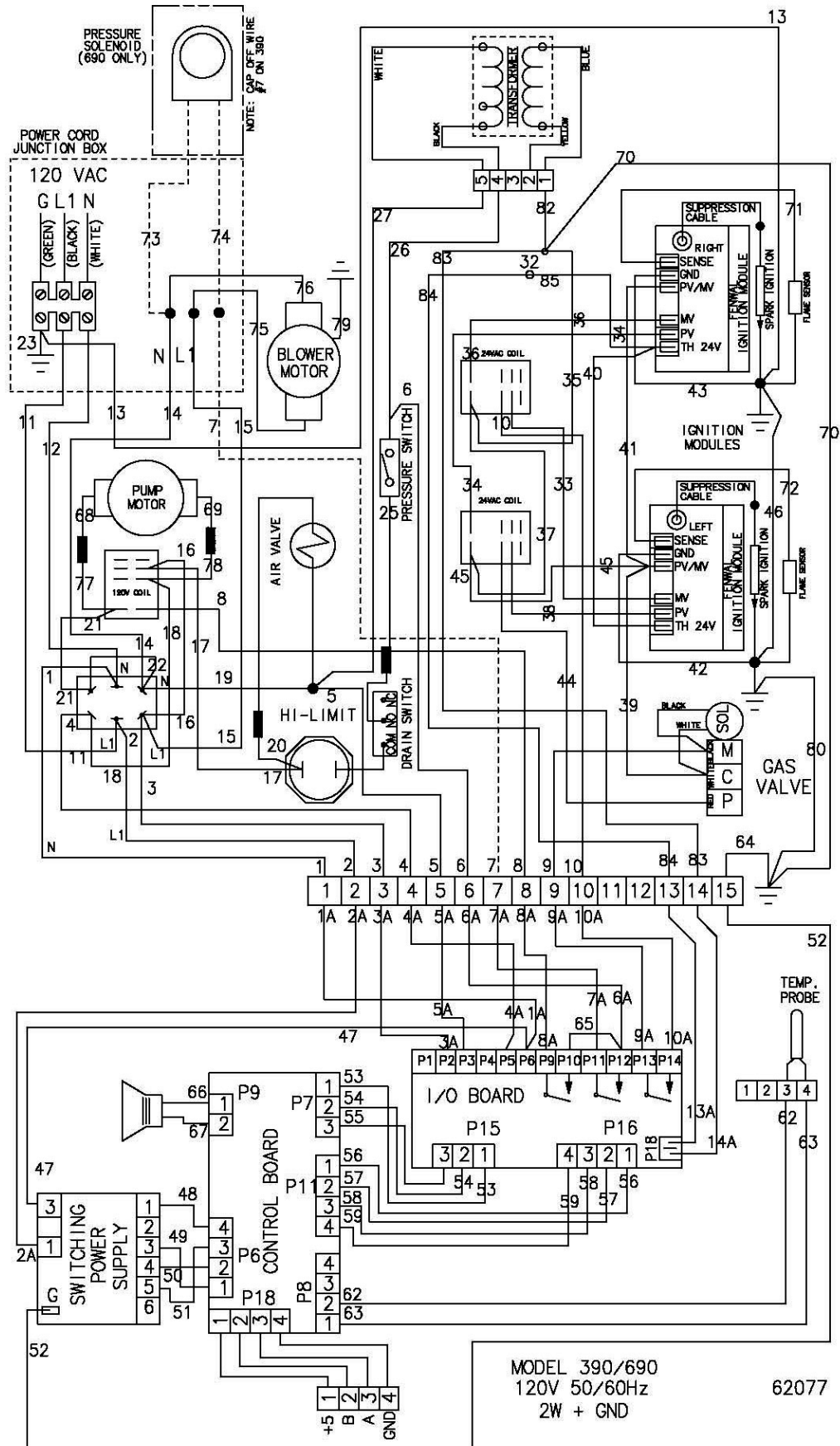

AP0803003 & above

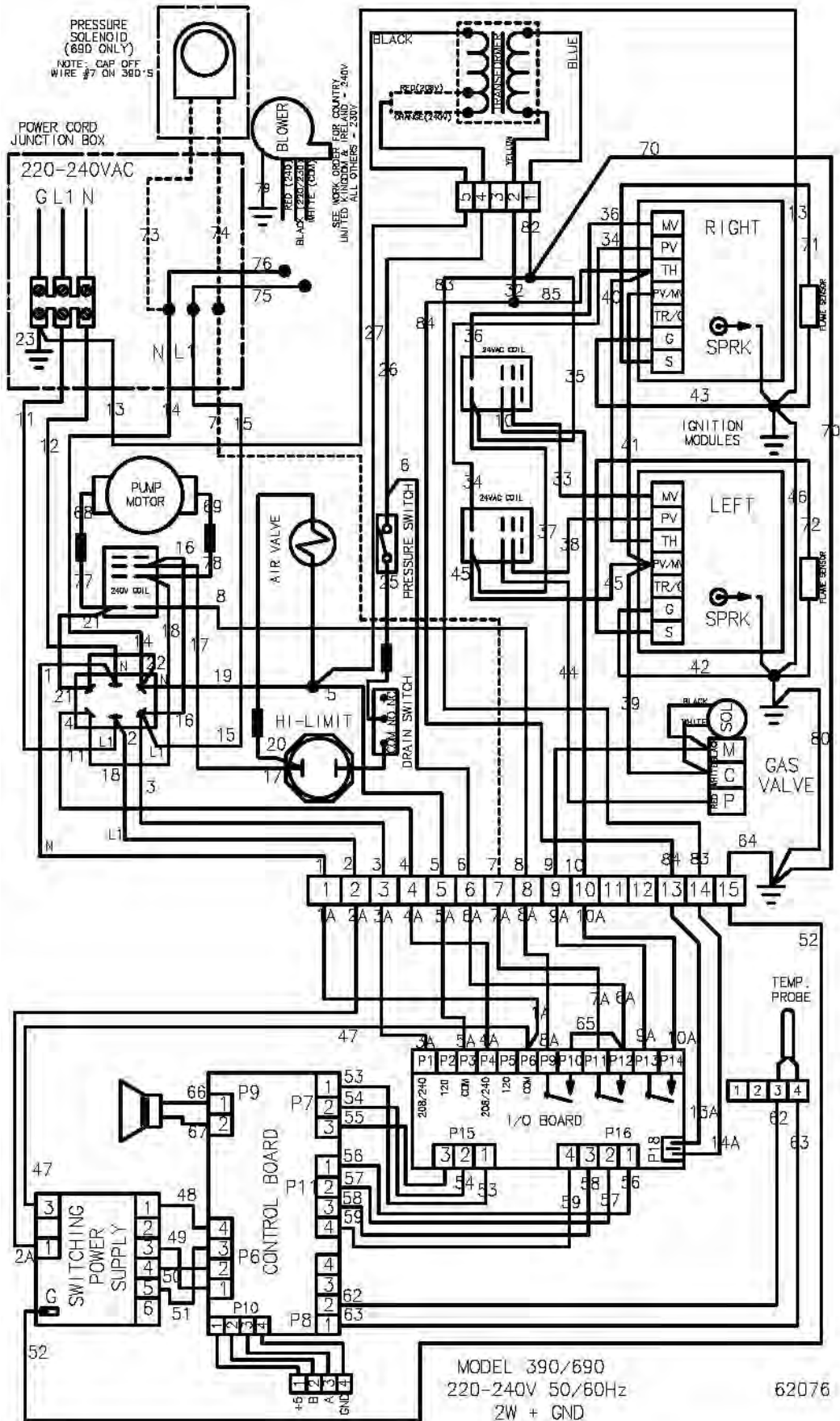

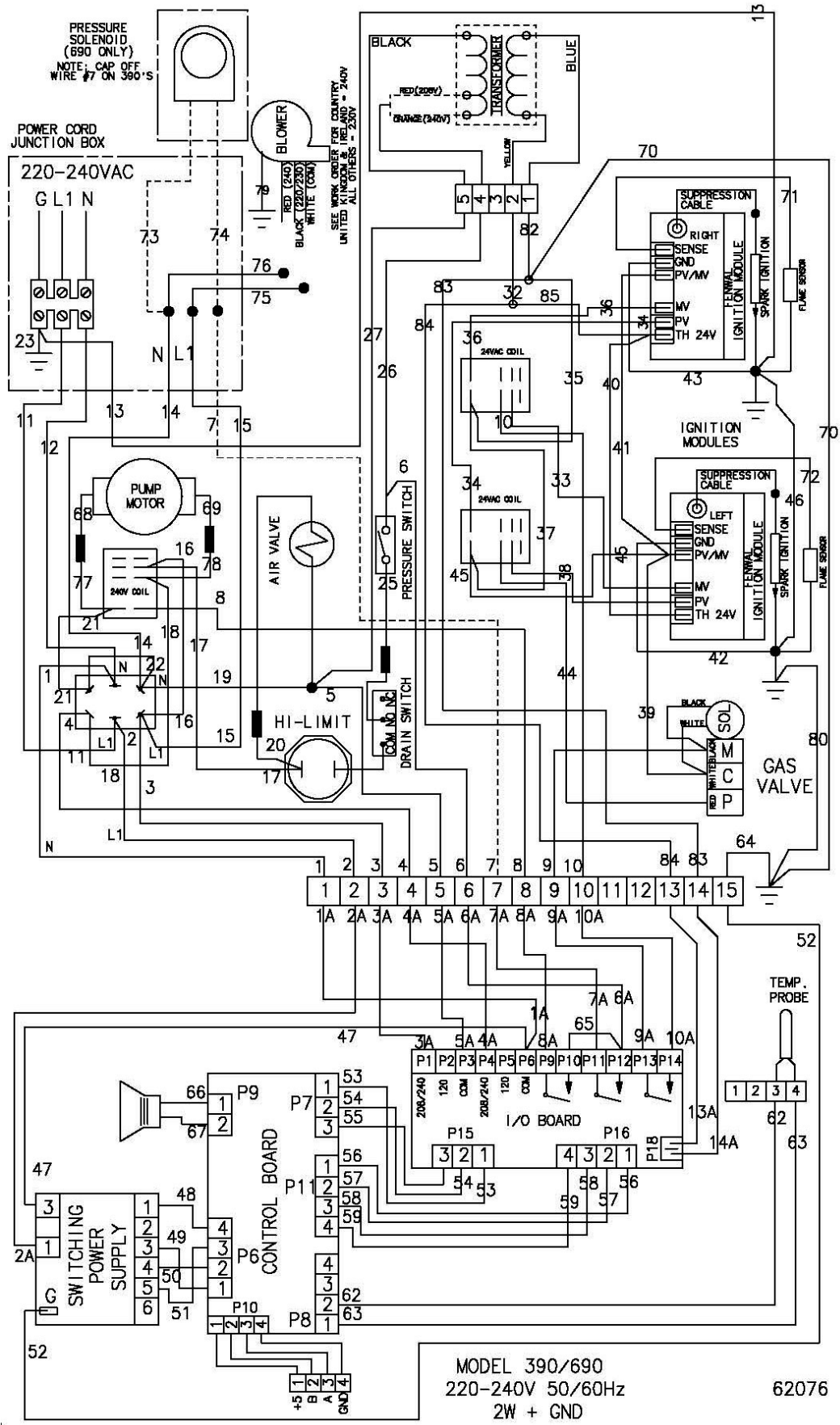

AP0803003 & above



AP0803002 & below

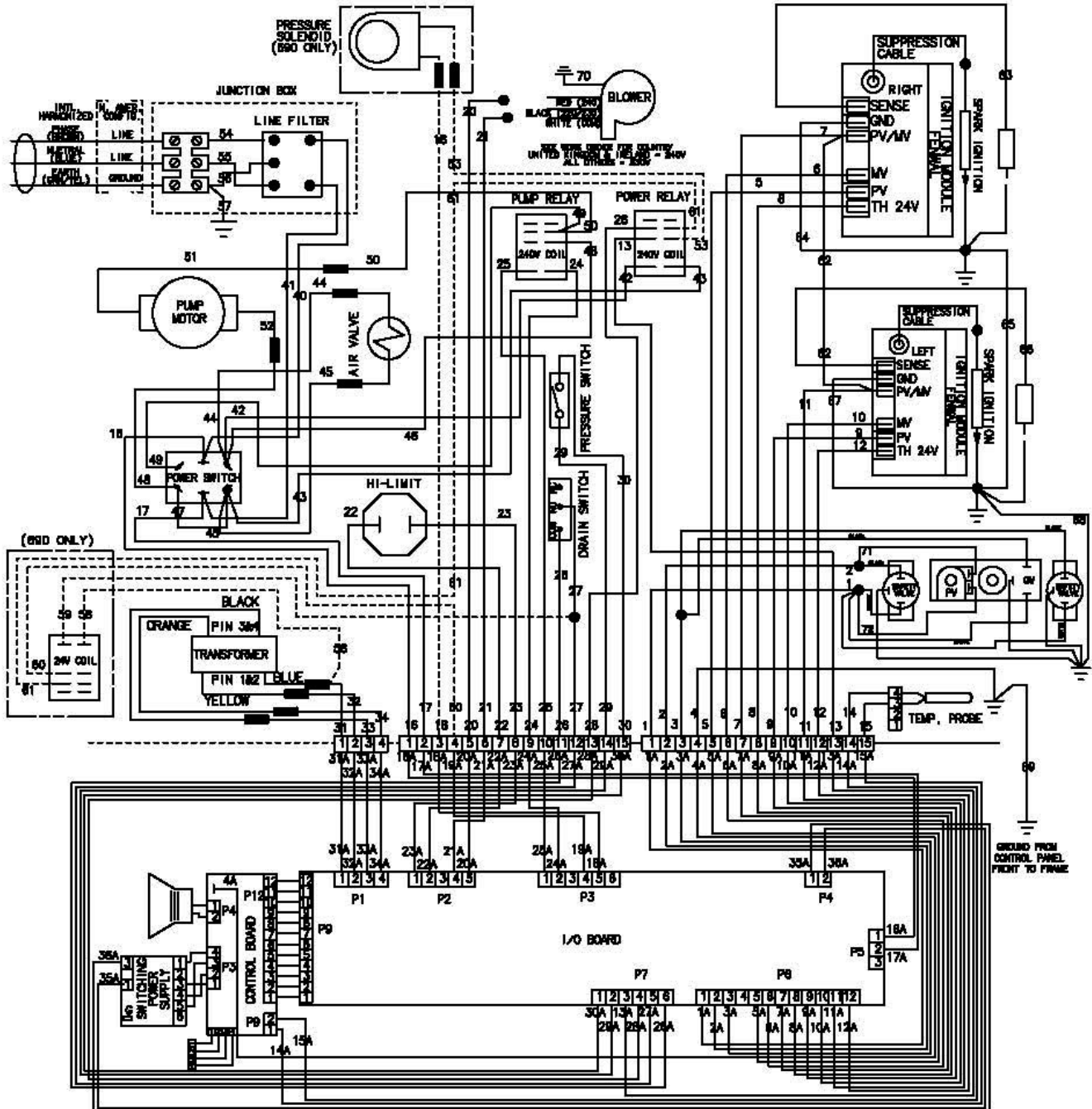

MODEL 390/690
230V 50/60 Hz
2+G

54914

AP0803003 & above

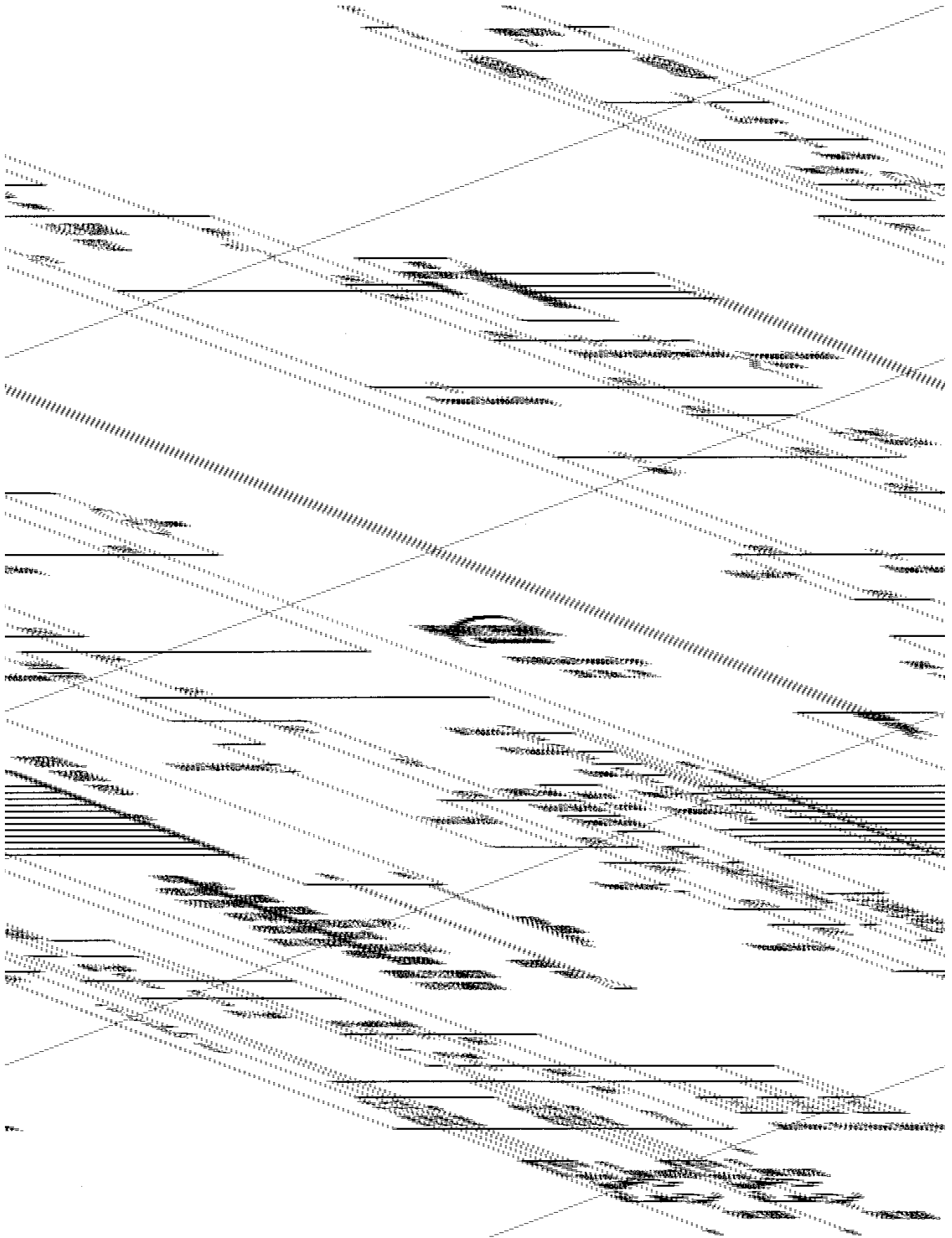

AP0803002 & below

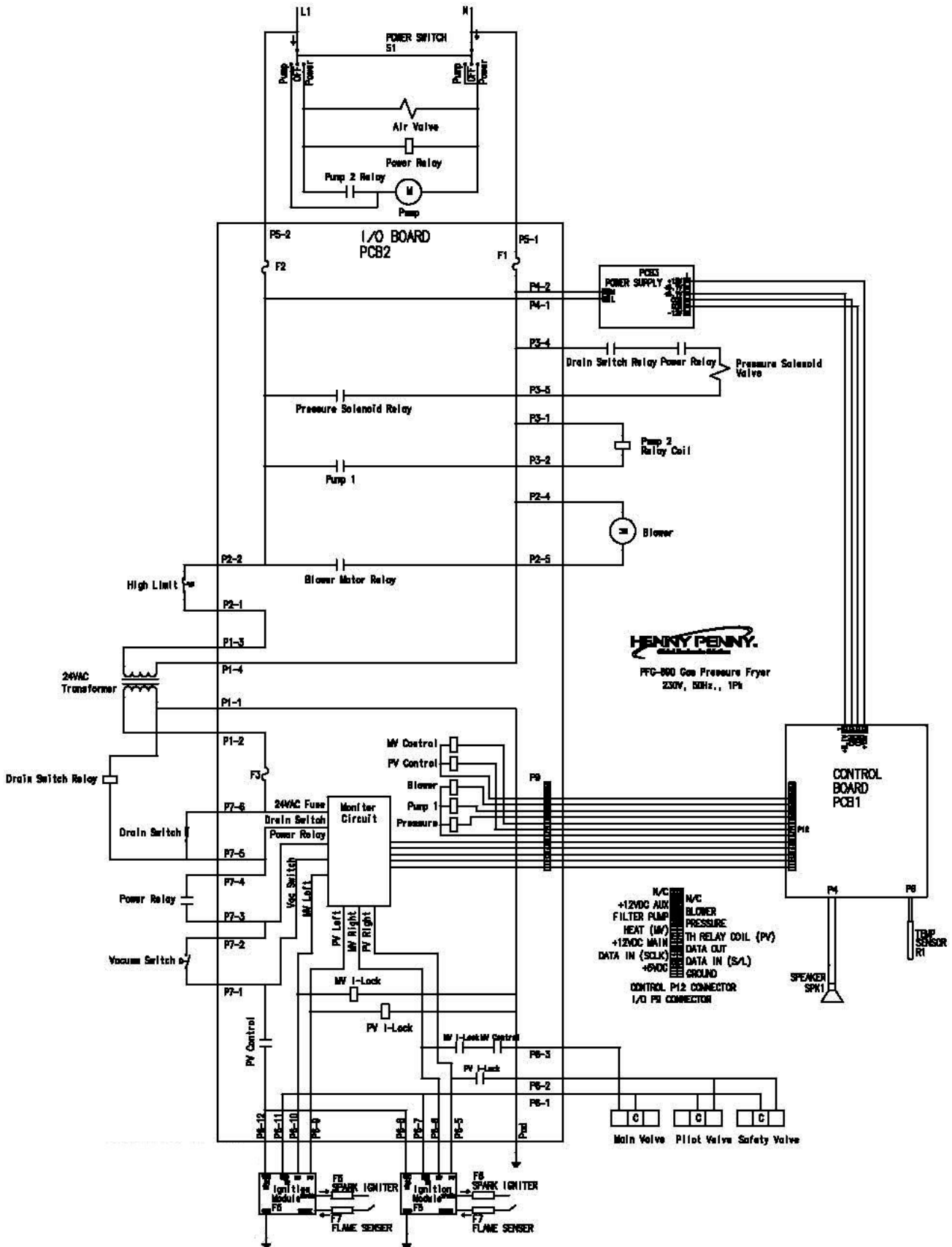

AP0803003 & above

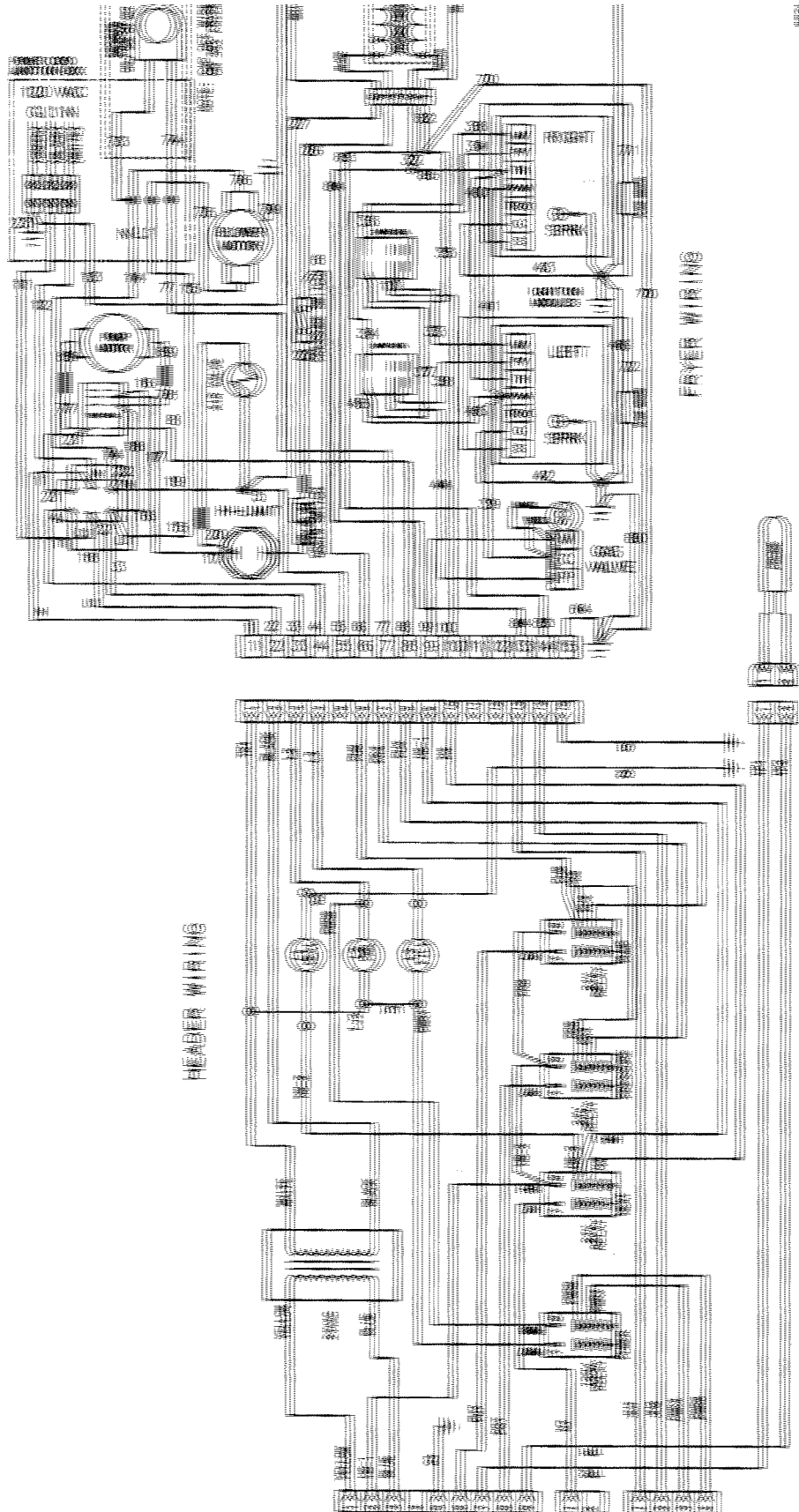

**100-120 Volt FAST Wiring Diagram
AP0803002 & below**

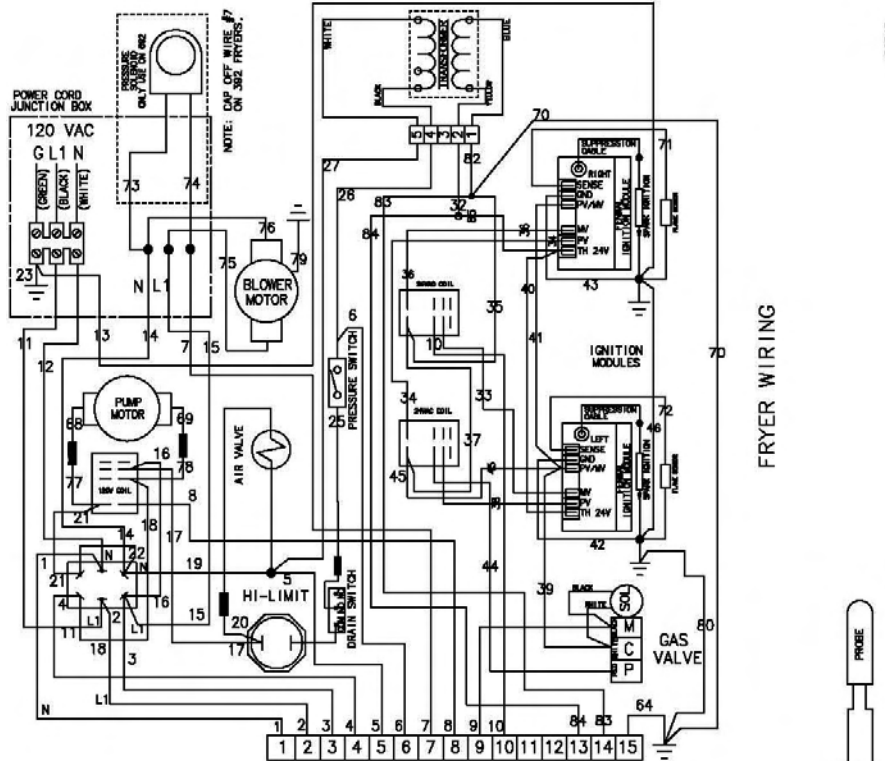

66245

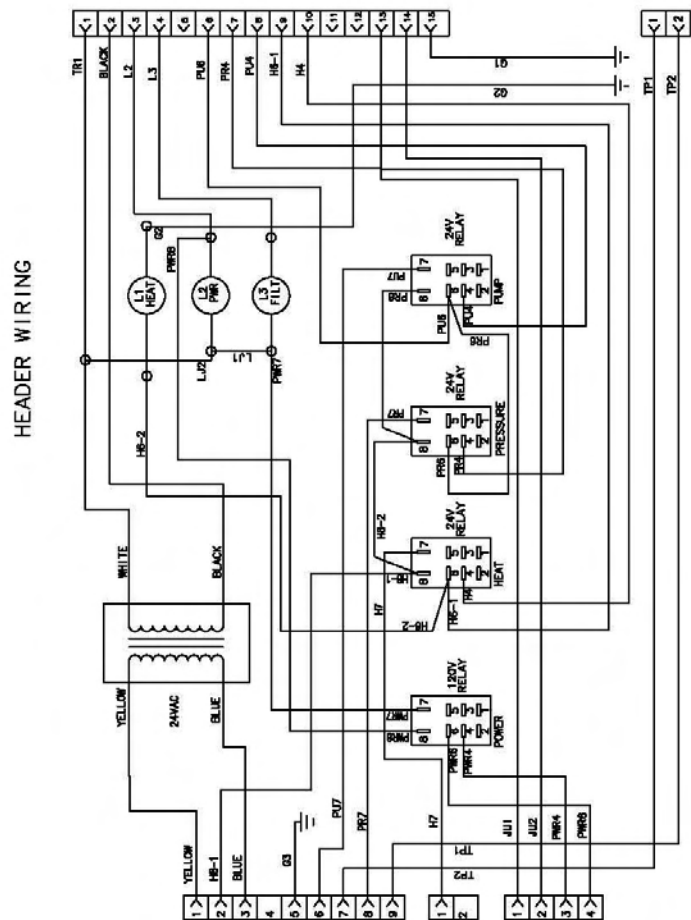

AP0803003 & above

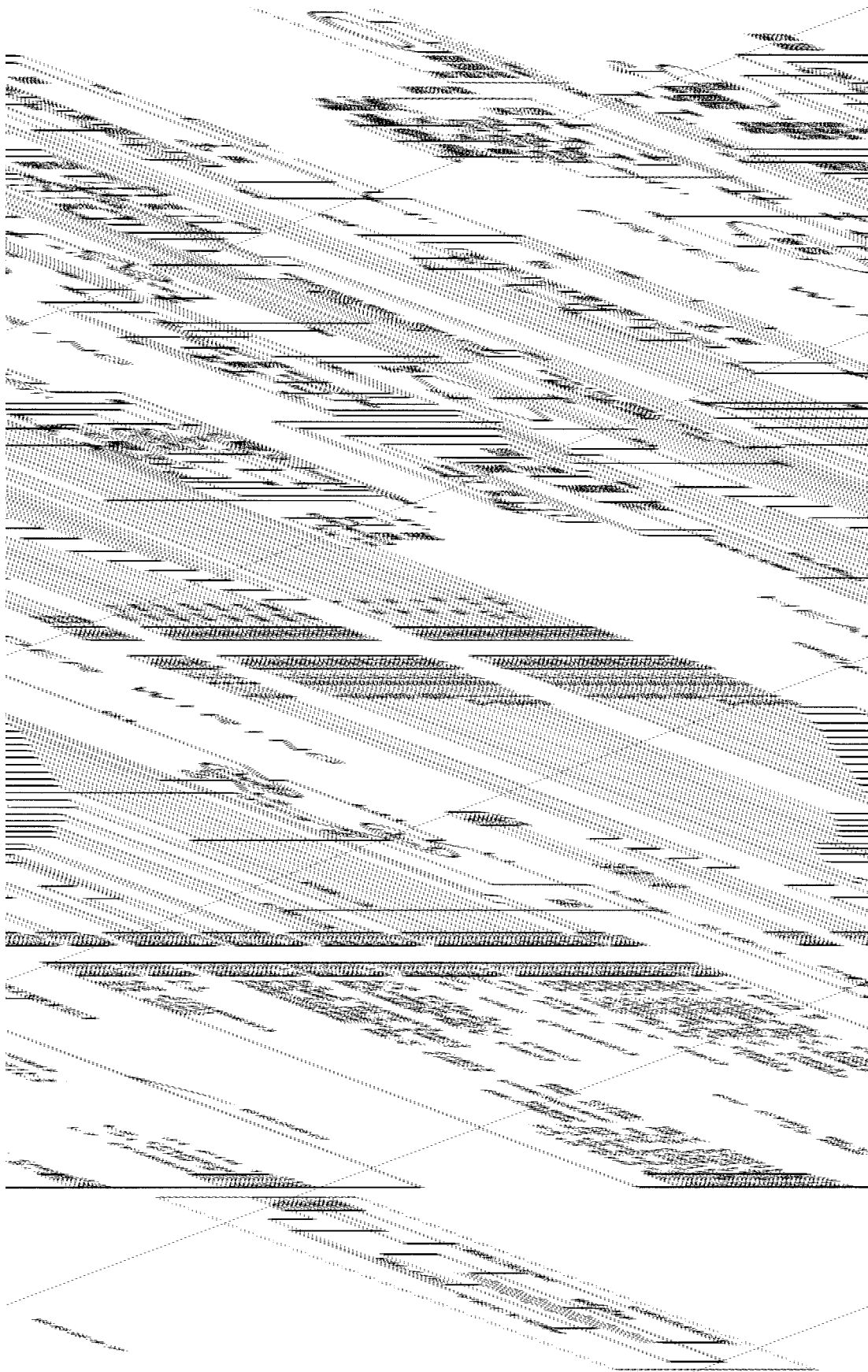

**230 Volt FAST Wiring Diagram
AP0803002 & below**

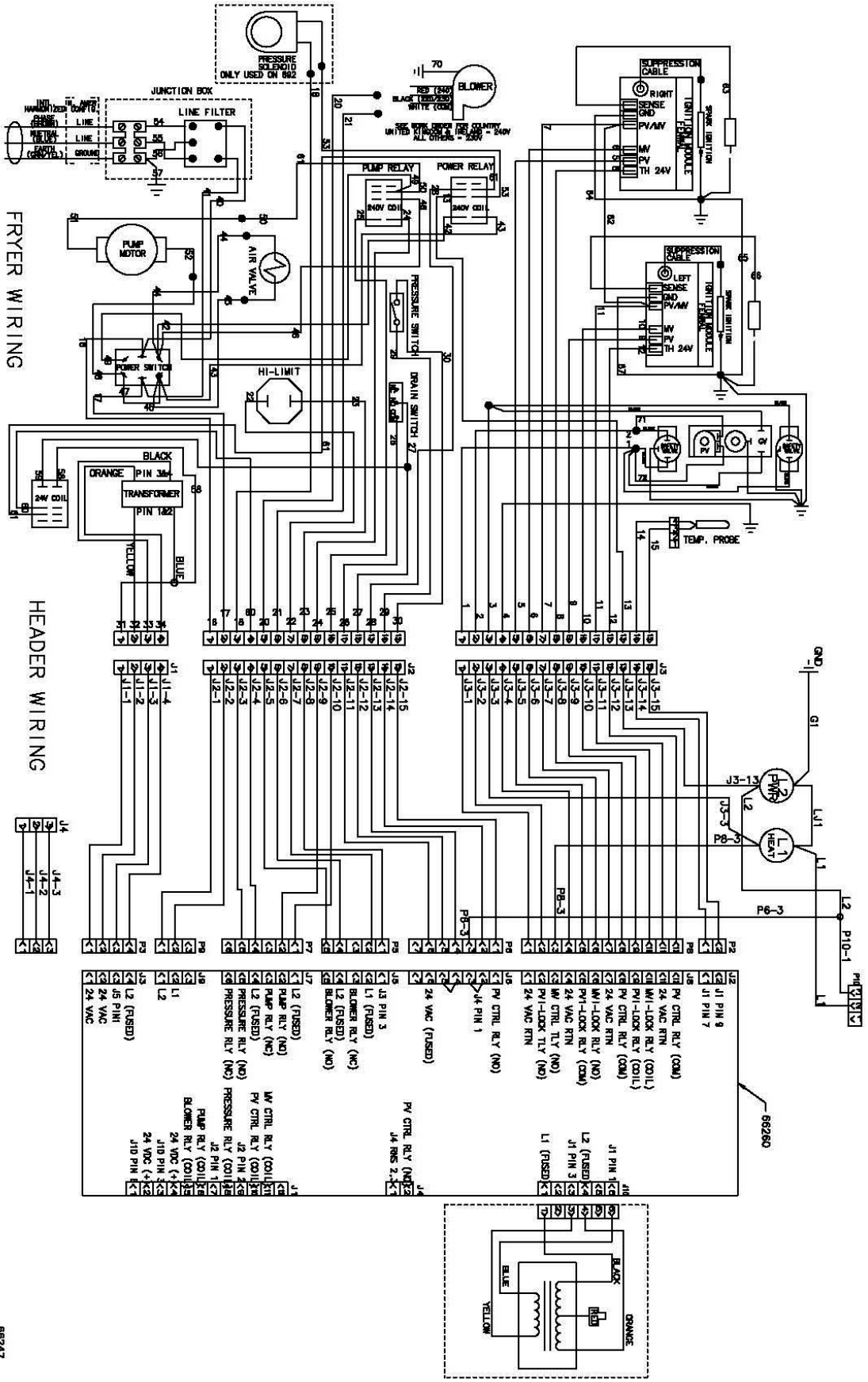

AP0803003 & above



**220-240 Volt FAST Wiring Diagram
AP0803002 & below**

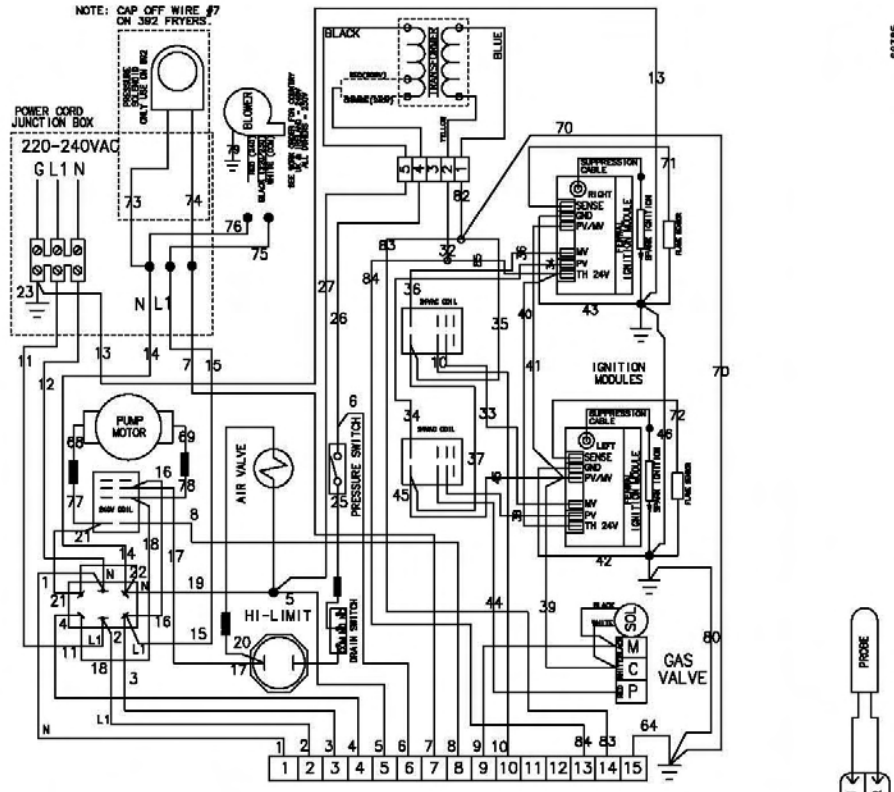

86385

HEADER WIRING

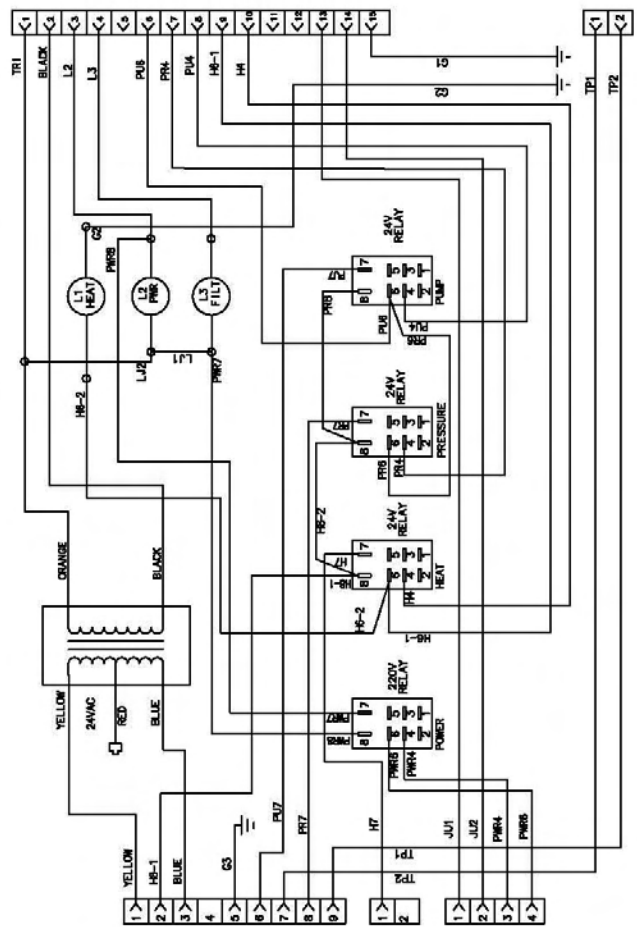

AP0803003 & above

LIMITED WARRANTY FOR HENNY PENNY EQUIPMENT

Subject to the following conditions, Henny Penny Corporation makes the following limited warranties to the original purchaser only for Henny Penny appliances and replacement parts:

NEW EQUIPMENT: Any part of a new appliance, except baskets, lamps, and fuses, which proves to be defective in material or workmanship within two (2) years from date of original installation, will be repaired or replaced without charge F.O.B. factory, Eaton, Ohio, or F.O.B. authorized distributor. Baskets will be repaired or replaced for ninety (90) days from date of original installation. Lamps and fuses are not covered under this Limited Warranty. To validate this warranty, the registration card for the appliance must be mailed to Henny Penny within ten (10) days after installation.

FILTER SYSTEM: Failure of any parts within a fryer filter system caused by the use of the non-OEM filters or other unapproved filters is not covered under this Limited Warranty.

REPLACEMENT PARTS: Any appliance replacement part, except lamps and fuses, which proves to be defective in material or workmanship within ninety (90) days from date of original installation will be repaired or replaced without charge F.O.B. factory, Eaton, Ohio, or F.O.B. authorized distributor.

The warranty for new equipment covers the repair or replacement of the defective part and includes labor charges and maximum mileage charges of 200 miles round trip for a period of one (1) year from the date of original installation.

The warranty for replacement parts covers only the repair or replacement of the defective part and does not include any labor charges for the removal and installation of any parts, travel, or other expenses incidental to the repair or replacement of a part.

EXTENDED FRYPOT WARRANTY: Henny Penny will replace any frypot that fails due to manufacturing or workmanship issues for a period of up to seven (7) years from date of manufacture. This warranty shall not cover any frypot that fails due to any misuse or abuse, such as heating of the frypot without shortening.

0 TO 3 YEARS: During this time, any frypot that fails due to manufacturing or workmanship issues will be replaced at no charge for parts, labor, or freight. Henny Penny will either install a new frypot at no cost or provide a new or reconditioned replacement fryer at no cost.

3 TO 7 YEARS: During this time, any frypot that fails due to manufacturing or workmanship issues will be replaced at no charge for the frypot only. Any freight charges and labor costs to install the new frypot as well as the cost of any other parts replaced, such as insulation, thermal sensors, high limits, fittings, and hardware, will be the responsibility of the owner.

Any claim must be presented to either Henny Penny or the distributor from whom the appliance was purchased. No allowance will be granted for repairs made by anyone else without Henny Penny's written consent. If damage occurs during shipping, notify the sender at once so that a claim may be filed.

THE ABOVE LIMITED WARRANTY SETS FORTH THE SOLE REMEDY AGAINST HENNY PENNY FOR ANY BREACH OF WARRANTY OR OTHER TERM. BUYER AGREES THAT NO OTHER REMEDY (INCLUDING CLAIMS FOR ANY INCIDENTAL OR CONSEQUENTIAL DAMAGES) SHALL BE AVAILABLE.

The above limited warranty does not apply (a) to damage resulting from accident, alteration, misuse, or abuse; (b) if the equipment's serial number is removed or defaced; or (c) for lamps and fuses. THE ABOVE LIMITED WARRANTY IS EXPRESSLY IN LIEU OF ALL OTHER WARRANTIES, EXPRESS OR IMPLIED, INCLUDING MERCHANTABILITY AND FITNESS, AND ALL OTHER WARRANTIES ARE EXCLUDED. HENNY PENNY NEITHER ASSUMES NOR AUTHORIZES ANY PERSON TO ASSUME FOR IT ANY OTHER OBLIGATION OR LIABILITY.

Revised 01/01/07

SECTION 3. PARTS INFORMATION

3-1. INTRODUCTION

This section lists the replaceable parts of the Henny Penny Model 690 Fryer.

3-2. GENUINE PARTS

Use only genuine Henny Penny parts in your fryer. Using a part of lesser quality or substitute design may result in damage to the unit or personal injury.

3-3. WHEN ORDERING PARTS

Once the parts that you want to order have been found in the parts list, write down the following information:

Example:

Item Number	<u>4</u>
Part Number	<u>16738</u>
Description	<u>High Limit</u>

From the data plate, list the following information:

Example:

Product Number	<u>01100</u>
Serial Number	<u>0001</u>
Voltage	<u>120</u>

3-4. PRICES

Your distributor has a price parts list and will be glad to inform you of the cost of your parts order.

3-5. DELIVERY

Commonly replaced items are stocked by your distributor and will be sent out when your order is received. Other parts will be ordered, by your distributor, from Henny Penny Corporation. Normally, these will be sent to your distributor within three working days.

3-6. WARRANTY

All replacement parts (except lamps and fuses) are warranted for 90 days against manufacturing defects and workmanship. If damage occurs during shipping, notify the carrier at once so that a claim may be properly filed. Refer to warranty on the facing page for other rights and limitations.

3-7. RECOMMENDED SPARE PARTS FOR DISTRIBUTORS

Recommended replacement parts, stocked by your distributor, indicated with √ in the parts lists. Please use care when ordering recommended parts, because all voltages and variations are marked. Distributors should order parts based upon common voltages and equipment sold in their territory.

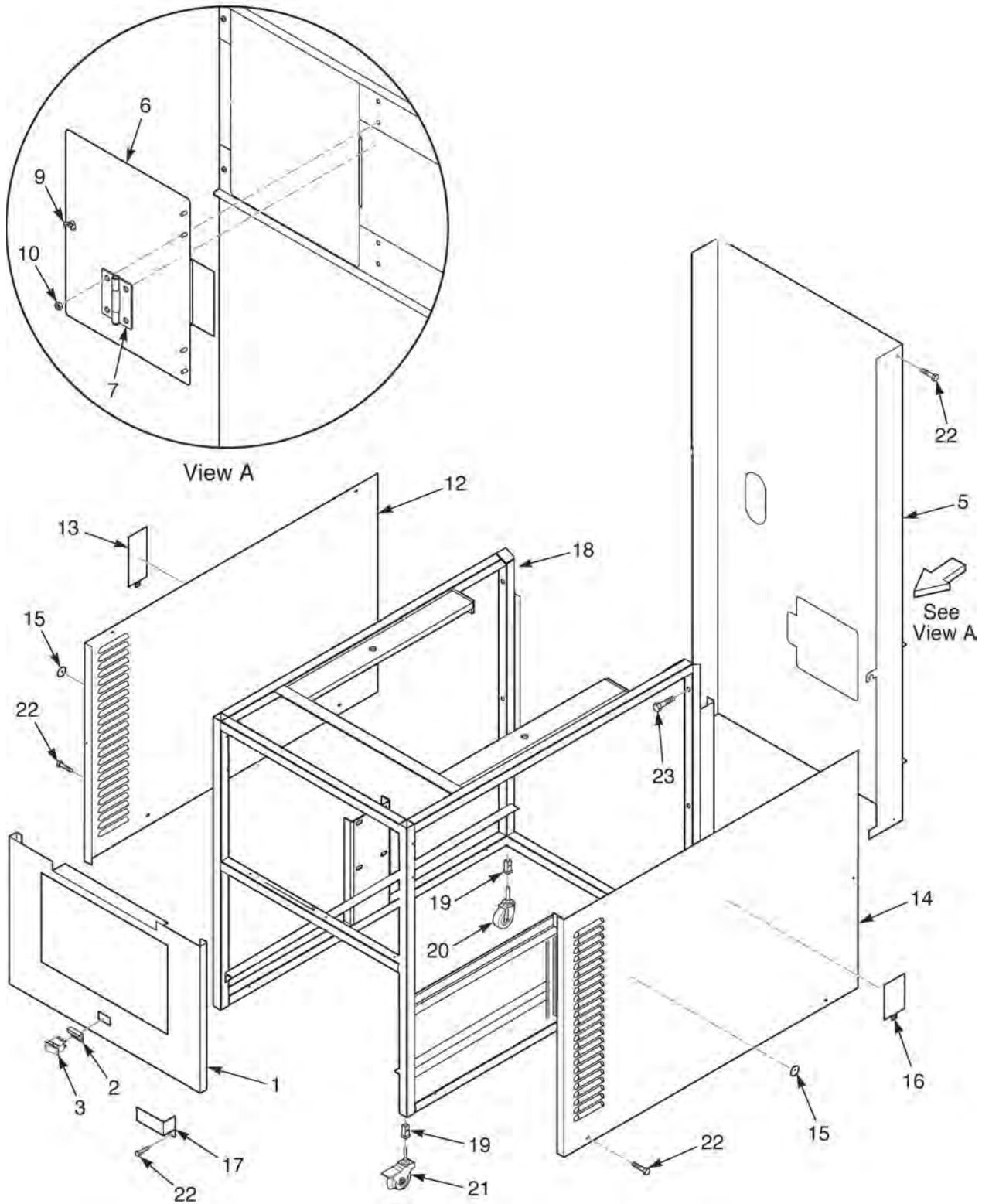
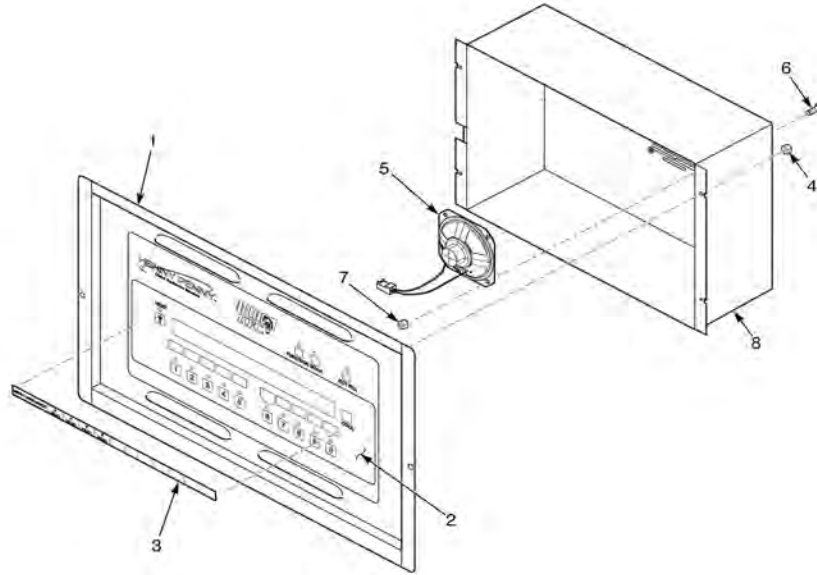

FIGURE 3-0. FRAME & COVER ASSEMBLY

Figure & Item No.	Part No.	Description	Qty.
3-0		FRAME & COVER ASSEMBLY	
1	39796	WELDMENT – CONTROL PANEL FRONT.....	1
2	53669	GUARD – POWER SWITCH.....	1
√ 3	29898	SWITCH – POWER.....	1
5	70591	REAR SHROUD – ACCESS ASSEMBLY.....	1
6	58258	. ACCESS COVER – STUD ASSEMBLY.....	1
7	58256	. HINGE – 2” LEAF HT.....	2
9	NS03-033	. NUT, WING – SS 10-24.....	1
10	NS03-002	. NUT, ACORN #10-24.....	8
12	70438	SIDE PANEL – LEFT.....	1
13	36337	DOOR – ACCESS.....	1
14	70439	SIDE PANEL – RIGHT.....	1
15	PL01-035	COVER – PILOT VIEW.....	2
16	35179	COVER – ACCESS COVER - SN: AP0603009 & BELOW....	1
16	36337	COVER – ACCESS COVER - SN: AP0603010 & ABOVE	1
17	51741	COVER, GAS VALVE WIRE.....	1
18	62194	FRAME ASSY – WELDMENT.....	1
19	54225	1” INSERT – LEG MACHINED.....	4
20	35154	CASTER, SWIVEL 4”.....	2
21	37246	CASTER W/BRAKE & SWIVEL LOCK.....	2
22	SC03-005	SCREW.....	8
23	SC01-215	SCREW.....	4
24*	51801	RUNNER - DRAIN PAN - SN BELOW HH001JJ.....	2

√ recommended parts

* not shown



**Figure &
Item No.**

Part No.

Description

Qty.

3-1		CONTROL PANEL	
√ 1	14418	KIT-CONTROL ASSY/AIR SWITCH MONITOR.- SMS-DOM....	1
√ 1	14245	KIT-CONVERSION TO SMS-DOM	1
√ 1	14427	KIT-CONTROL -240V-NON-SMS TO SMS-DOM	1
√ 1	14749	KIT-CONTROL -AIR SWITCH MONITOR - INT'L	1
√ 1	14750	KIT-CONTROL -240V-NON-SMS TO SMS - INT'L.....	1
√ 1	14753	KIT-CONVERSION TO SMS - INT'L	1
1	14788	KIT-120V 692 FAST to 690 SMS	1
1	14923	KIT-691 CONVERSION TO SMS - CE	1
√ 1	56834RB	CONTROL ASSY – KFC 690 NON-SMS - 120V.....	1
√ 1	70944RB	CONTROL ASSY – KFC 690 - 120V - NO SETPTS - INT'L.....	1
√ 1	55300RB	CONTROL ASSY – 220-240V F690 - W/SETPTS	1
√ 1	92836	ASSY-CONTROL-KFC ZIGB 690-DOM	1
√ 1	70952RB	CONTROL ASSY -KFC 690 -208-240 -NO SETPTS - INT'L.....	1
√ 1	21363RB	CONTROL ASSY – KFC 690 - CE.....	1
2	56829	. CONTROL DECAL – KFC 690 NON-SMS.....	1
2	50624	. CONTROL DECAL – 8 HEAD KFC.....	1
2	55574	. CONTROL DECAL – CE 690	1
3	54922	. . MENU CARD – 690	1
3	59516	. . MENU CARD – CE NON ENGLAND	1
3	76896	. . MENU CARD – ENGLAND	1
4	NS02-005	. NUT	4
√ 5	51877	. WIRE/SPEAKER ASSY	1
6	SC01-049	. SCREW.....	4
7	NS02-005	. NUT	4
8	72500	. SHIELD - CONTROL PANEL.....	1
9*	30614	. TRANSFORMER-208/240V Primary, 24V Secondary - CE.....	1

√ recommended parts

* not shown

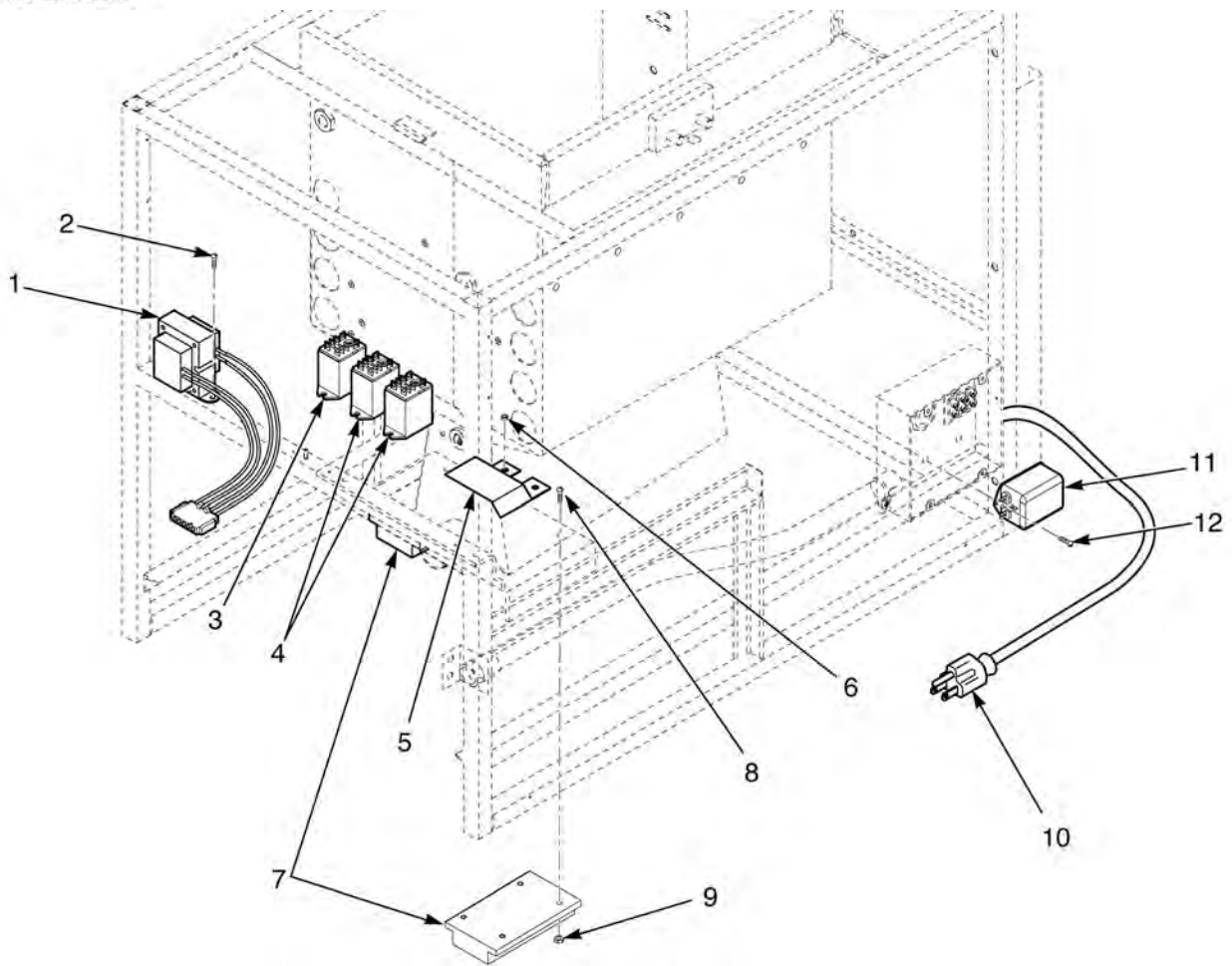

Figure & Item No.	Part No.	Description	Qty.
3-2		ELECTRICAL CONTROLS	
√ 1	60207	TRANSFORMER ASSY – 120V.....	1
√ 1	60536	TRANSFORMER ASSY – 24V/230V.....	1
2	SC03-005	SCREW	2
√ 3	140049	KIT - RELAY - 120V - SN: AP0903010 & Below	1
√ 3	81914	RELAY - 120V - SN: AP0903011 & Above	1
√ 3	56394	POWER RELAY - 240V.....	1
√ 4	60818	RELAY, 24V Coil (10A@120V; 12A@240VAC	2
5	62053	SHIELD – WIRE – RH BURNER NON CE.....	1
6	NS02-005	NUT.....	2
√ 7	14932	KIT - IGNITION MODULE - SN: AP0803002 & below	2
√ 7	77839	IGNITION MODULE - SN: AP0803003 & above	2
√ 7	14921	KIT - IGNITION MODULE - CE - SN: AP0803002 & below	2
√ 7	77602	IGNITION MODULE - CE - SN: AP0803003 & above	2
8	SC01-214	SCREW #10-32 X 1 PH THD SS	4
9	NS02-001	NUT HEX KEPS #10-32 C.....	4
10	53656	POWER CORD – 120V	1
√ 11	54988	FILTER – 220V – 50/60HZ GA CE.....	1
12	SC01-006	SCREW #10-32 X 3/8 PH THD C.....	2
13*	77923-01	CABLE - SUPPRESSION - 18 IN.....	1
13*	77923-02	CABLE - SUPPRESSION - 12 IN.....	1

√ recommended parts/* not shown

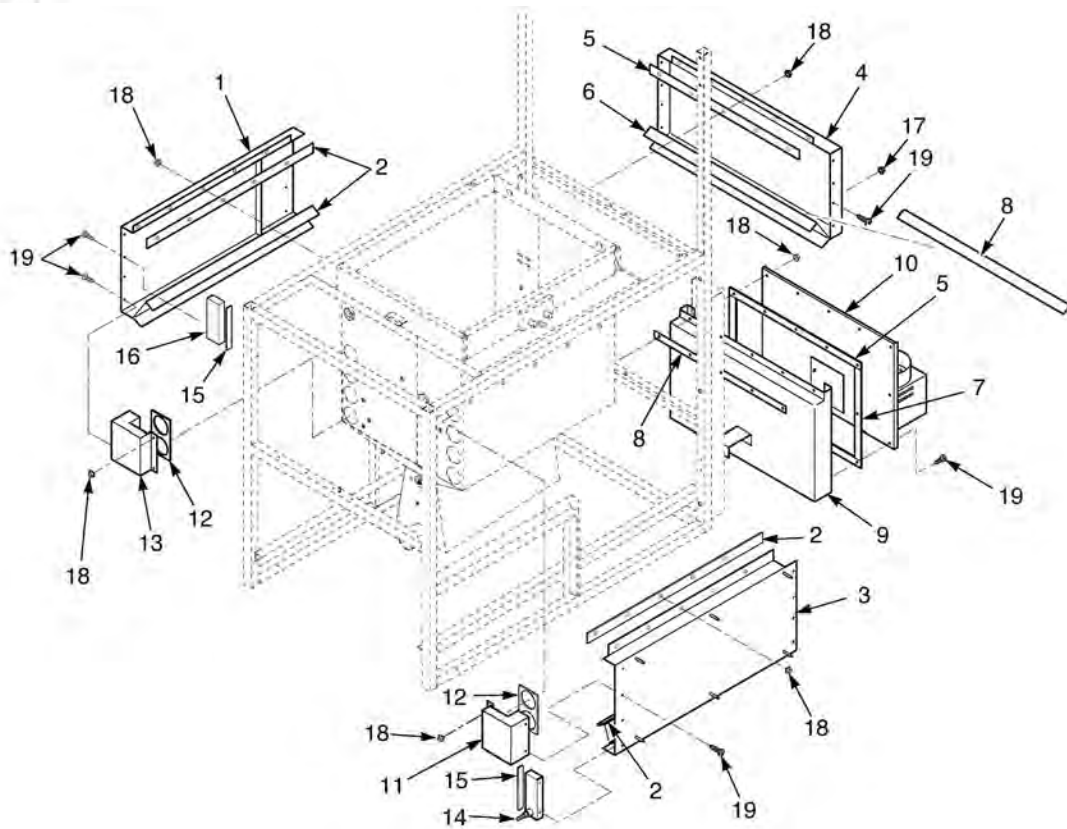

Figure & Item No.	Part No.	Description	Qty.
3-3A		FRYPOT COVERS & INSULATION	
1	52799	ASSY-INSUL/LFT. C/CHAMBER.....	1
2	52041	INSULATION-C/CHAMBER MOUNTIN.....	4
3	52798	ASSY-INSUL/RT. C/CHAMBER	1
4	52800	ASSY-INSUL/REAR C/CHAMBER	1
5	52038	INSULATION-LOWER CHAMBER DUC.....	3
6	52040	INSULATION-REAR C/CHAMBER.....	1
7	51897	INSULATION-LOWER CHAMBER COV.....	2
8	52039	INSULATION-C/CHAMBER COLLAR.....	2
9	52120	ASSY-LOWER C/CHAMBER DUCT.....	1
10	52801	ASSY-INSUL/CHAMBER COVER - SN: AP080208 & below.....	1
10	79392-01	COMBUSTION BOX PLATE - SN: AP080209 & above	1
		(non-CE-0-5000 ft & Maritus Island)	
10	79392-02	COMBUST. BOX PLATE-SN: AP080209 & above (Mexico).....	1
10	79392-03	COMBUSTION BOX PLATE - SN: AP080209 & above	1
		(CE-Above 5000 ft).....	
11	52795	ASSY INSUL/TUBE-CHAMBER RT.	1
12	52792	INSULATION-TUBE TO C/CHAMBER	2
13	52794	ASSY-INSUL/TUBE-CHAMBER LFT.	1
14	52797	ASSY-INSUL/LOWER CHAMBER CAP.....	1
15	52793	INSULATION - C/CHAMBER CAP	2
16	52796	ASSY-INSUL/UPPER CHAMBER CAP.....	1
17	NS02-005	NUT HEX KEPS #6-32C	5
18	NS02-006	NUT HEX KEPS #10-24C	34
19	SC02-014	SCREW #8 AB X 3/8 PH #400SS.....	27
20*	14928	KIT - FILTER DILUTION BOX - SN: AP0802028 & below	1

* not shown

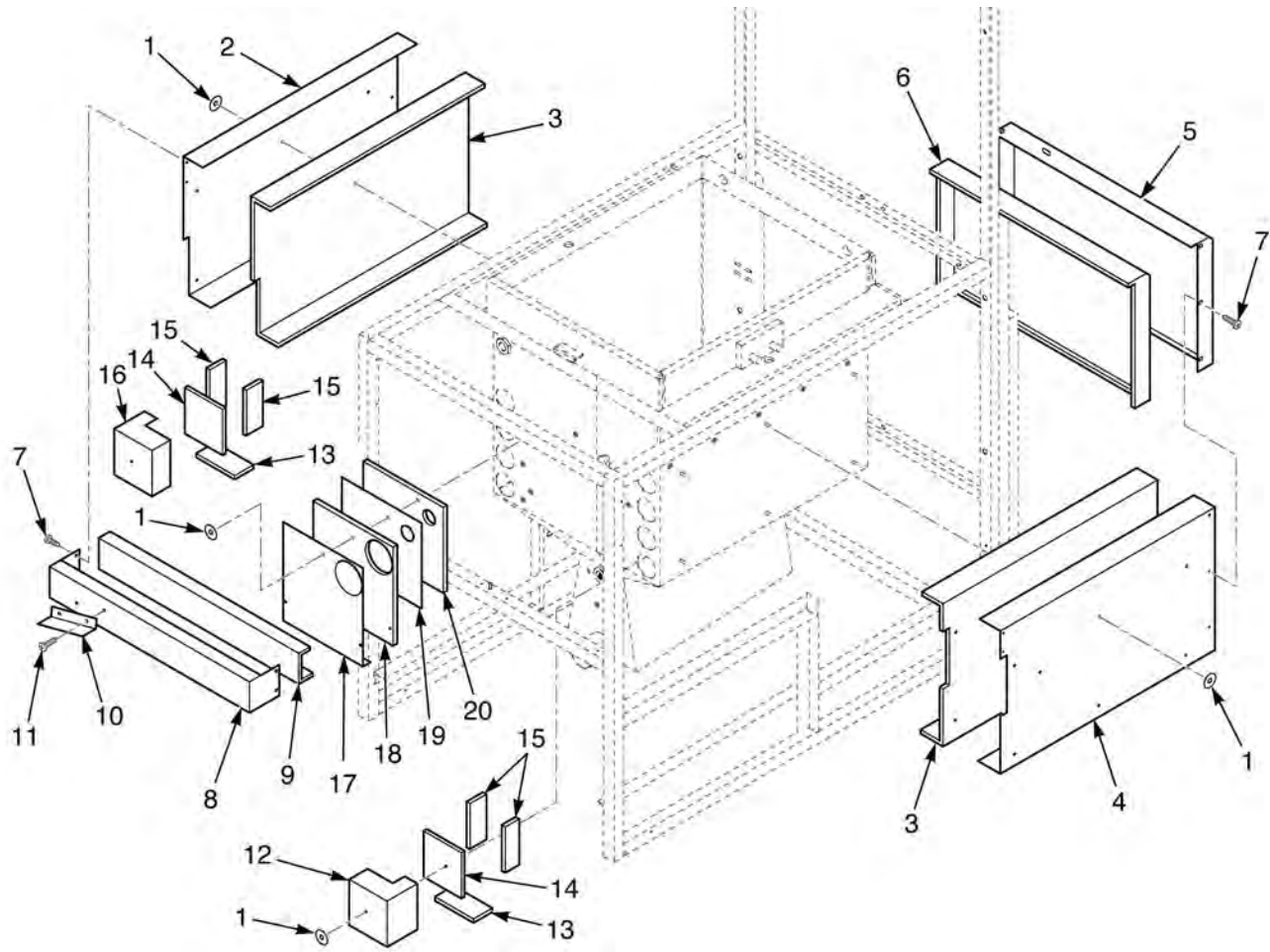

Figure & Item No.	Part No.	Description	Qty.
3-3B		INSULATION COVERS	
1	WA02-001	WASHER – INSULATION 1-1/2” DIA.	17
2	51763	INSULATION COVER – LEFT.....	1
3	51892	INSULATION – C/CHAMBER SIDE	2
4	51765	INSULATION COVER – RIGHT	1
5	51759	INSULATION COVER – REAR.....	1
6	51893	INSULATION – REAR C/CHAMBER.....	1
7	SC02-014	SCREW #8-AB X 3/8 PH #400SS	10
8	51739	TOP FRONT INSULATION PANEL.....	1
9	51894	INSULATION – TOP FRONT PANEL	1
10	62060	SHIELD – HIGH LIMIT	1
11	SC03-005	SCREW SD #8 X 1/2 PH PHD.....	2
12	51753	INSULATION COVER – TUBE TRAN RH	1
13	53661	INSUL. – TUBE/CHAMBER-SIDE	4
14	53662	INSUL – TUBE/CHAMBER-BOTTOM	2
15	53660	INSUL. – TUBE/CHAMBER-BACK	2
16	51755	INSULATION COVER – TUBE TRANS.....	1
17	51821	CONTROL INSULATION COVER LH.....	1
18	53659	INSULATION – POT FRONT (FOIL).....	1
19	51806	POT FRONT INSULATION COVER.....	1
20	53658	INSULATION – POT FRONT	1

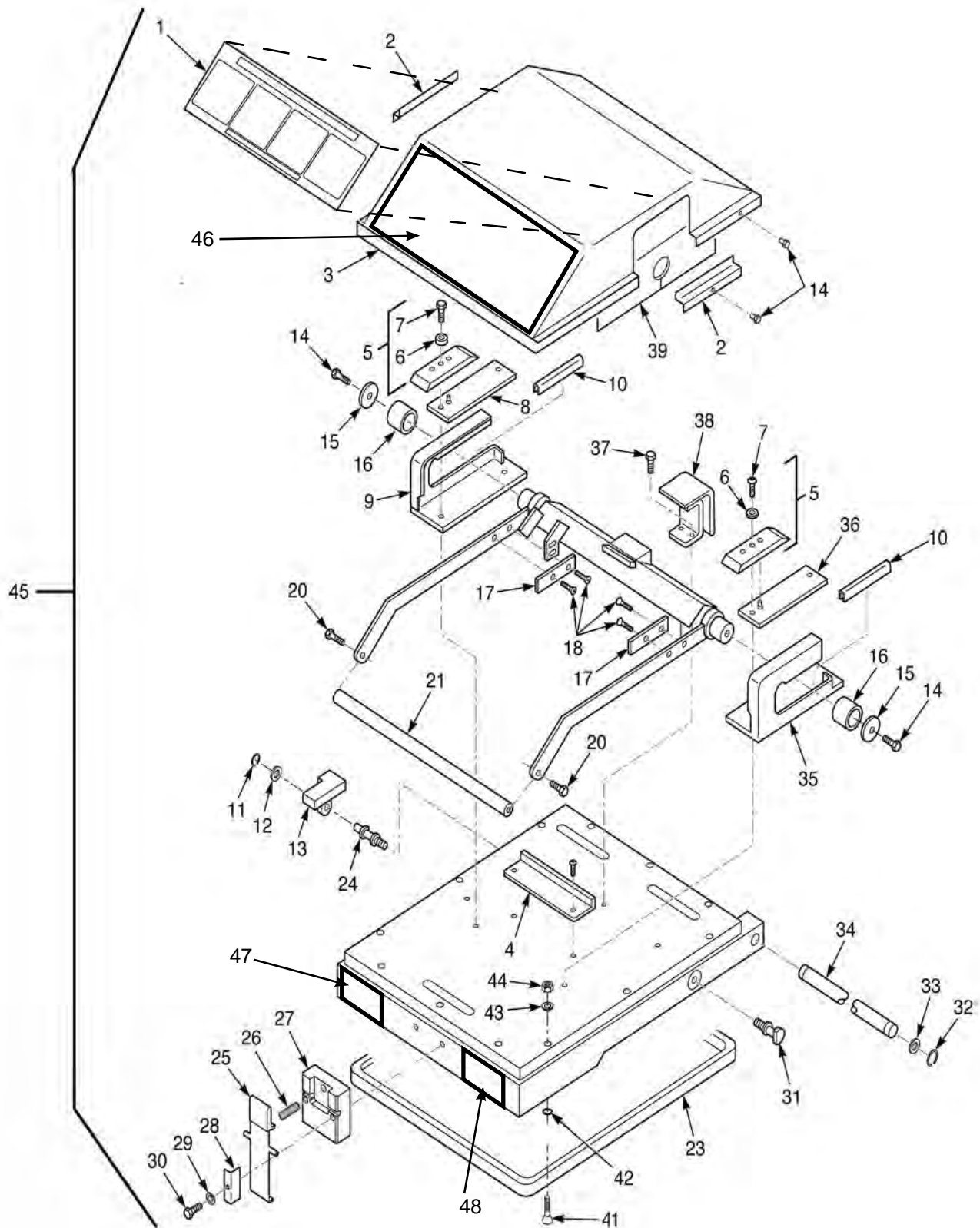

FIGURE 3-4. LID & COVER ASSEMBLY

Figure & Item No.	Part No.	Description	Qty.
3-4		LID & COVER ASSEMBLY	
1	35792	LID INSTRUCTION LABEL	1
2	35675	FILLER-LID	2
3	35243	COVER-MAIN LID	1
4	35413	PLATE-TRIP	1
√ 5	52627	PRESSURE PAD ASSY.	2
6	49852	. BUSHING-PRESSURE PAD	2
7	SC01-204	. SCREW 1/4-20X1.00 SOCK BUTT	2
8	49962	PLATE, SHIM ASSY. (L.H.)	1
9	49890	PLATE, CAM GUIDE (L.H.)	1
10	35359	SLIDE (6")	2
11	RR01-004	RING, RETAINING 1/2"	1
12	WA01-020	WASHER, LID STOP	1
13	51531	CAST, LID STOP	1
14	SC01-074	SCREW, #10-32 x 1/2 PH THD SS	8
15	35223	WASHER, SPECIAL	1
16	35227	ROLLER, LINKAGE SHAFT	2
17	35339	GUIDE, HANDLE SIDE	2
18	SC01-062	SCREW, #6-32 x 3/8 PH FH	4
20	SC01-041	SCREW, 5/16-18 x 1.00 HEX HD C	2
21	36285	WELDMENT, HANDLE TAP PLATE	1
√ 23	34526	GASKET, LID - SN: AP0712013 & below	1
√ 23	66620	GASKET, LID - SN: AP0712014 & above	1
24	35945	PIN, LID SUPPORT	1
25	52497	LATCH ASSEMBLY, COATED	1
26	52498	LATCH SPRING	1
27	59169	LATCH BRACKET, LID (MACHINED)	1
28	51707	LATCH BRACKET, LID	2
29	LW02-006	LOCKWASHER, LATCH	2
30	SC01-248	SCREW, LATCH, 10-32 x 1.25 PH THD SS	2
31	35032	PIN, LID SUPPORT	1
32	RR01-010	RING, RET. 3/4 SHAFT SS	2
33	36312	WASHER, LID HINGE	2
34	51697	PIN, LID HINGE	1
35	49895	PLATE, CAM GUIDE (R.H.)	1
36	49963	PLATE SHIM ASSEMBLY (R.H.)	1
37	SC01-146	SCREW, 1/4-20 x 3/4 HEX HD SS	2
38	52477	LIFT, LID	1
√ 39	35465	CAM SLIDE FILLER	2
41	SC01-195	SCREW, 8-32 x 1-7/16 PH FHD S	12
42	OR01-005	O-RING, 5/16 x 1/16 DIA.	12
43	LW01-002	LOCKWASHER, SPLIT RING 1/4 S	12
44	NS01-008	NUT, 8-32 HEX	12
45	72379	ASSY-690 REBUILT LID	1
46	66444	LABEL-OPERATIONAL HAZARDS	1
47	37933	LABEL-DANGER STIRRING	1
48	37934	LABEL - DANGER SHORTENING	1

√ recommended parts

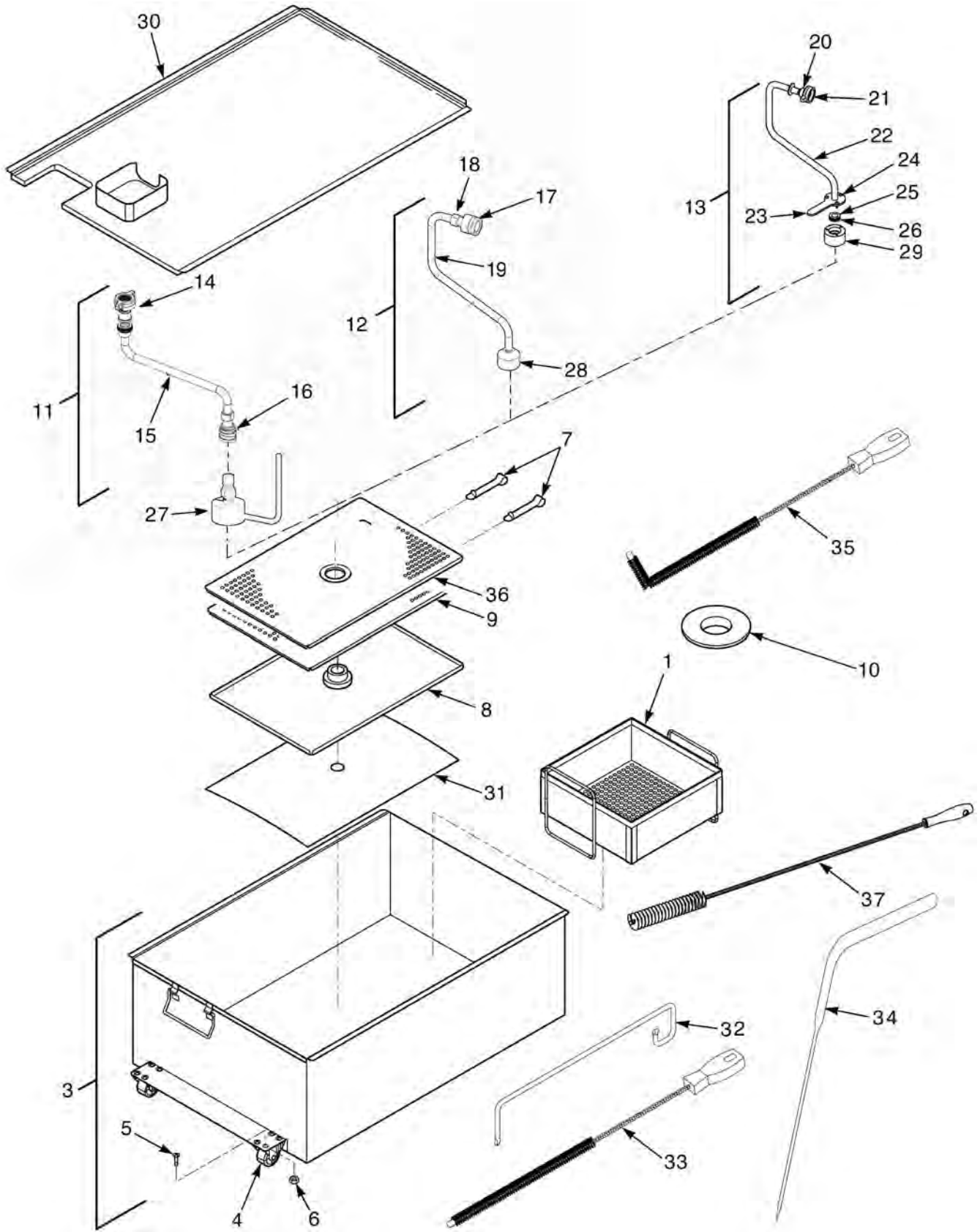

FIGURE 3-5. DRAIN PAN & FILTER ASSEMBLY

Figure & Item No.	Part No.	Description	Qty.
3-5		DRAIN PAN & FILTER ASSEMBLY	
1	52194	CRUMB CATCHER (OPTIONAL) (REQUIRES ITEM 10)	1
2*	03204	CRUMB CATCHER BASKET W/HANDLE (OPTIONAL)..... (FITS INSIDE FRYPOT)	1
2*	21010	. "COLD ZONE" CRUMB CATCHER BASKET ASSEMBLY..	1
2*	24429	. HANDLE - CRUMB BASKET	1
3	52496	FILTER DRAIN PAN ASSEMBLY	1
4	52487	. CASTER	2
5	SC01-009	. SCREW 1/4-20 X 1/2.....	8
6	NS02-002	. NUT 1/4-20	8
7	17505	FILTER CLIPS.....	2
8	17503 (use 14671)	BOTTOM FILTER SCREEN (SN: KH031JJ AND BELOW)	1
8	17503 (use 14674)	BOTTOM FILTER SCREEN (SN: KH032JJ TO AP0503043).....	1
8	65447	BOTTOM FILTER SCREEN (SN: AP0503044 AND ABOVE)...	1
9	No Longer Available	TOP FILTER SCREEN	1
10	36305	WASHER, STANDPIPE (USE WITH ITEM 1).....	1
11	55876	STANDPIPE ASSEMBLY (S/N KH031JJ & BELOW).....	1
12	62081	STANDPIPE ASSEMBLY (S/N KH032JJ to AH085JB)	1
13	24212	STANDPIPE ASSEMBLY (S/N AH086JB to AP0503043)	1
13	14658	STANDPIPE ASSEMBLY (S/N AP0503044 AND ABOVE)	1
14	69289	. FILTER UNION ASSEMBLY (S/N KH031JJ & BELOW)	1
15	51799	. FILTER DRAIN LINE (S/N KH031JJ & BELOW).....	1
16	55507	. DISCONNECT-FEMALE (S/N KH031JJ & BELOW)	1
17	35396	. CAP-FILTER NOZZLE (S/N KH032JJ to AH085JB)	1
18	17333	. RH-DISCONNECT FEMALE (S/N KH032JJ to AH085JB).....	1
19	62010	. TUBE-FILTER TO DISCONN. (S/N KH032JJ to AH085JB) ...	1
√ 20	17431 (use 69289)	. UNION - MALE FITTING	1
√ 21	17432 (use 69289)	. UNION - HANDLE FITTING.....	1
22	24211	. WELDMENT, FILTER TUBE AND WASHER.....	1
23	23740	. HANDLE, STANDPIPE 8 HEAD	1
24	SC01-245	. SCREW 10-32 X 1/2.....	3
25	23804	. INSERT, FILTER NUT	1
26	OR01-007	. O-RING, FILTER NUT INSERT.....	1
27	55877	. FILTER NUT (S/N KH031JJ & BELOW)	1
28	65208	. FILTER NUT - (S/N KH032JJ to AH085JB)	1
29	23803	. FILTER NUT - (S/N AH086JB to AP0503043)	1
29	66535	. FILTER NUT - SS (S/N AP0503044 & ABOVE)	1
30	62082	FILTER DRAIN PAN COVER ASSEMBLY	1
√ 31	12102	FILTER ENVELOPE PAPER (100 PER CARTON).....	1
32	52209	ROD - CLEAN OUT	1
√ 33	52208	BRUSH - 24 IN (61 CM).....	1
34	35310	STIRRER	1
√ 35	12126	BLACK L-BRUSH	1
36	65211	CRUMB CATCHER	1
37	35771	BRUSH - CLEAN-OUT - 35 IN. (89 CM).....	1
38*	14895	KIT - SPCL SHORT FLTR KFC/FALCON.....	1

√ recommended parts
 * not shown

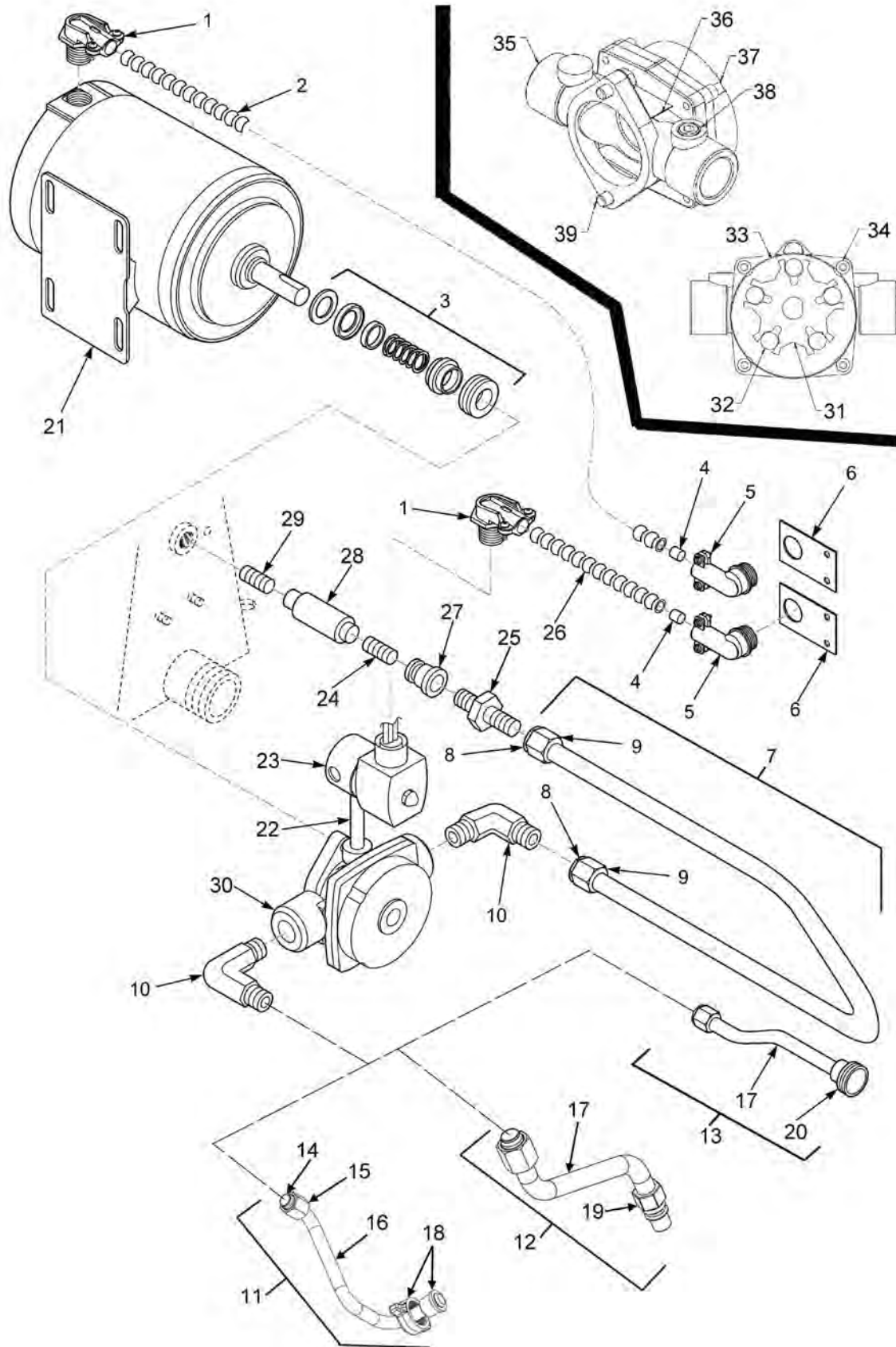

FIGURE 3-6. FILTER PUMP ASSEMBLY (BELOW SN: AP0401001)

Figure & Item No.	Part No.	Description	Qty.
3-6		FILTER PUMP ASSEMBLY (BELOW SN: AP0401001)	
1	18107	CONDUIT CONNECTOR 3/8 X 90	2
2	54484	BLOWER/PUMP – FLEXIBLE CONDUIT	1
√ 3	17476	PUMP SEAL KIT	1
4	18105	ANTI SHORT 3/8 INCH	2
5	18644	CONDUIT CONNECTOR 3/8 X 90	2
6	51831	PUMP CONDUIT BRACKET	2
7	55757	ASSY – OIL RETURN LINE.....	1
8	16808	. SLEEVE, FITTING.....	2
9	16809	. NUT, FITTING.....	2
10	17407	CONNECTOR, 1/2 MALE ELBOW	2
11	55435	TUBE ASSY – DISCON. TO PUMP (S/N KH031JJ & LOWER)...	1
12	62009	TUBE ASSY – DISCON. TO PUMP (S/N KH032JJ to AH086JB)..	1
13	24225	TUBE ASSY – DISCON. TO PUMP (S/N AH086JB to AP0401001)	1
14	16808	. SLEEVE, FITTING.....	1
15	16809	. NUT, FITTING.....	1
16	55434	. TUBING, DISCONNECT TO PUMP (S/N KH031JJ & LOWER)	1
17	66676	. TUBING, DISCONNECT TO PUMP (S/N KH032JJ to AP0401001)	1
18	69289	. FILTER UNION ASSEMBLY (S/N KH031JJ & LOWER).....	1
19	17334	. RH-DISCONNECT MALE (S/N KH032JJ to AH086JB)	1
√ 20	17430 (use 69289)	. UNION, MALE FITTING (S/N AH086JB to AP0401001).....	1
√ 21	67583	MOTOR – FILTER PUMP - 1/2 HP.....	1
22	62050	NIPPLE 1/4 NPT X 2.0	1
√ 23	52125	AIR-SOLENOID VALVE 120V.....	1
√ 23	54908	AIR-SOLENOID VALVE 240V.....	1
24	FP02-024	NIPPLE 3/8 CLOSE	1
25	16807	FITTING, CONNECTOR, MALE	1
26	54486	AIR VALVE – FLEXIBLE CONDUIT	1
27	FP01-122	REDUCER 3/8 TO 1/2	1
√ 28	35472	CHECK VALVE – PRESSURE	1
29	FP02-007	NIPPLE 3/8 X 1-1/2	1
30	17437	PUMP SUBASSY 5 GPM.....	1
√ 31	17447	ROTOR - PUMP.....	1
√ 32	17446	ROLLER - TEFLON SET	1
√ 33	17453	PUMP O RING GASKET	1
√ 34	SC01-132	1/4-20 X 5/8 SOC HD CAP SCREW	4
√ 35	17454	BODY - PUMP.....	1
√ 36	17456	PUMP SHIELD	2
√ 37	17451	COVER - PUMP.....	1
√ 38	FP01-020	PLUG 1/4 HEX COUNTERSUNK.....	1
39	SC01-026	SCREW 5/16-18 X 3/4 HEX HD C.....	2
40*	85777	1/2” PUMP AND MOTOR (Includes Items 3, 21, and 30).....	1

√ recommended parts
 * not shown

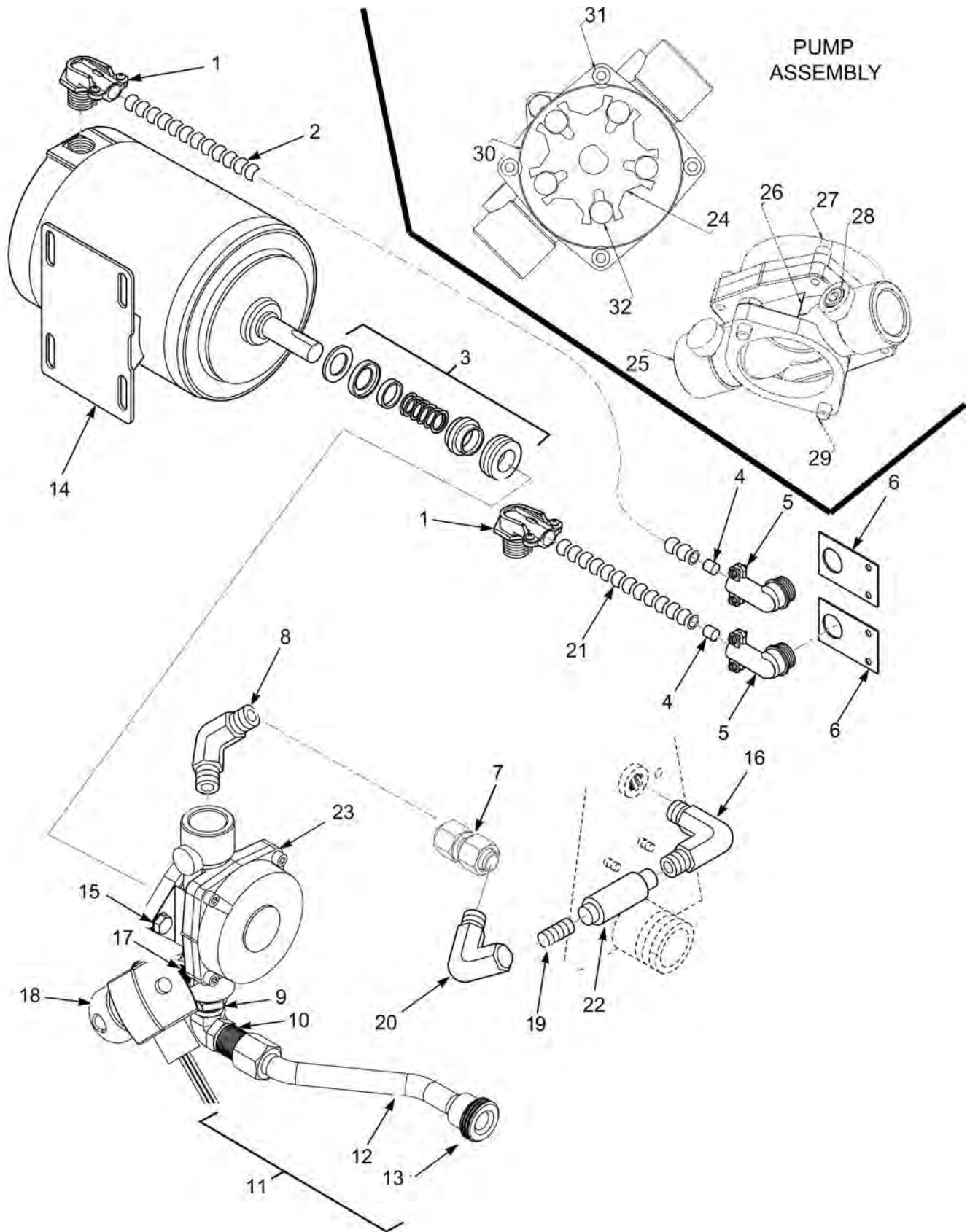

FIGURE 3-7. FILTER PUMP ASSEMBLY (SN: AP0401001 & ABOVE)

Figure & Item No.	Part No.	Description	Qty.
3-7		FILTER PUMP ASSEMBLY (SN: AP0401001 & ABOVE)	
1	18107	CONDUIT CONNECTOR 3/8 X 90	2
2	54484	BLOWER/PUMP – FLEXIBLE CONDUIT	1
√ 3	17476	PUMP SEAL KIT.....	1
4	18105	ANTI SHORT 3/8 INCH	2
5	18644	CONDUIT CONNECTOR 3/8 X 90	2
6	51831	PUMP CONDUIT BRACKET	2
7	65080	ASSY – PUMP TO CHECK VLV TUBE-390/690.....	1
8	FP01-169	CON - 90 MALE 3/4 TUBE 3/4 NPT.....	1
9	FP01-089	BUSHING - REDUCING - 3/4M TO 1/2.....	1
10	17407	CONNECTOR, 1/2 MALE ELBOW	1
11	66574	ASSY – DISCON. TO PUMP	1
12	65079	. ASSY – DISCON. TO PUMP TUBE.....	1
√ 13	17430 (use 69289)	. UNION, MALE FITTING	1
√ 14	67583	MOTOR – FILTER PUMP - 1/2 HP.....	1
15	LW02-014	LOCKWASHER - 5/16 INT STAR	1
16	FP01-173	ELBOW - 3/4 NPT X 90 MALE NICKEL.....	1
17	62050	NIPPLE 1/4 NPT X 2.0.....	1
√ 18	52125	AIR-SOLENOID VALVE 120V	1
√ 18	54908	AIR-SOLENOID VALVE 240V	1
19	FP02-037	NIPPLE 3/4 X 2.5 LG BI.....	1
20	FP01-168	CON - 90 FEMALE 3/4 TUBE 3/4 NF	1
21	54486	AIR VALVE – FLEXIBLE CONDUIT	1
√ 22	21800	VALVE - 3/4 CHECK	1
23	64218	ASSY - FILTER PUMP 8 GPM.....	1
√ 24	23468	ROTOR - 8 GPM PUMP.....	1
√ 25	23467	BODY - 8 GPM PUMP.....	1
√ 26	17456	PUMP SHIELD.....	2
√ 27	23470	CAP - 8 GPM PUMP	1
√ 28	FP01-020	PLUG 1/4-18 HEX LEVEL SEAL	1
√ 29	SC01-026	SCREW 5/16-18 X 3/4 HEX HD C	2
√ 30	17453	PUMP O RING GASKET.....	1
√ 31	SC01-132	1/4-20 X 5/8 SOC HD CAP SCREW	4
32	23469	ROLLER - 8 GPM PUMP	5
33*	69355	PUMP & MOTOR ASSEMBLY	1

√ recommended parts

* not shown

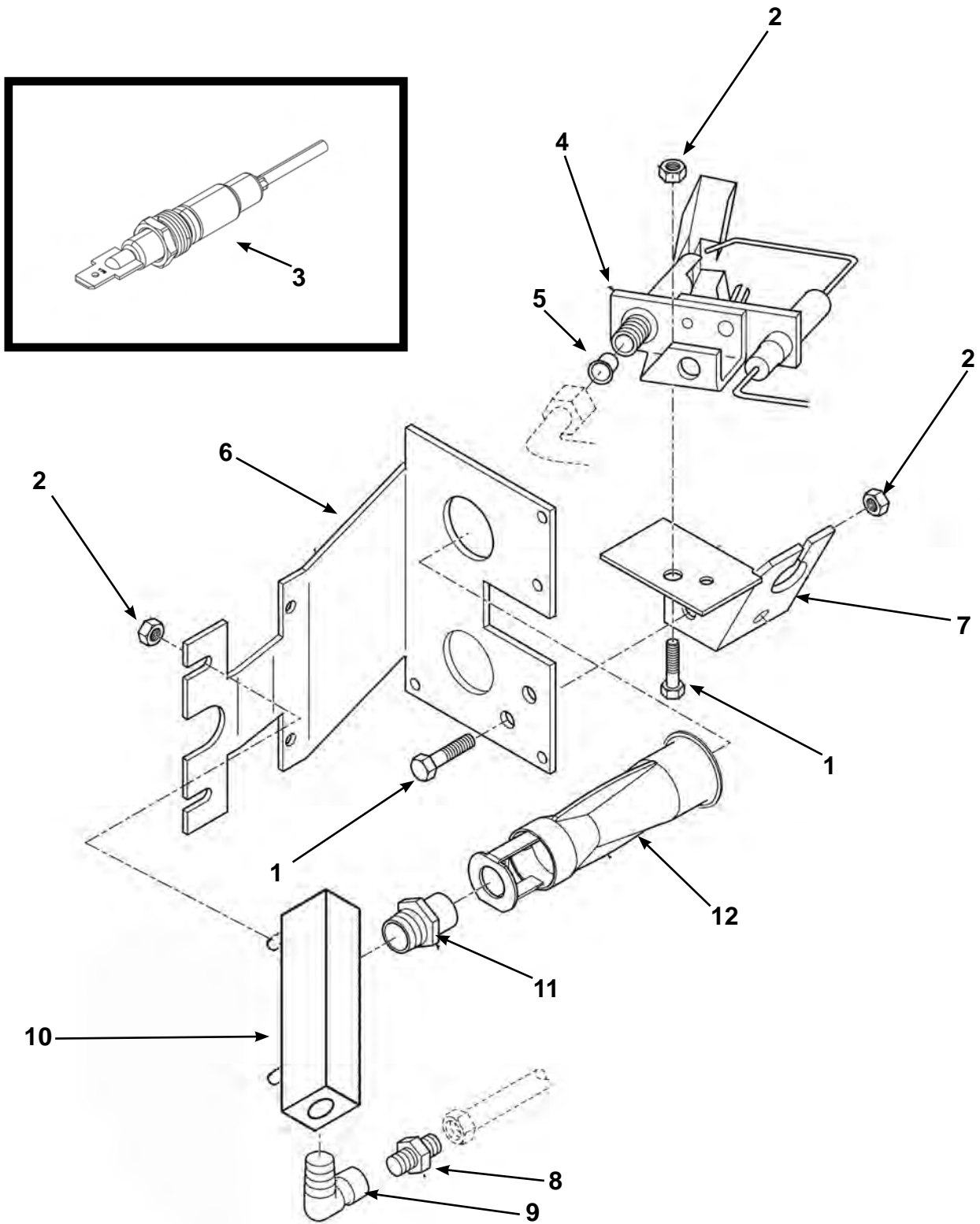

FIGURE 3-8. GAS BURNER ASSEMBLY

Figure & Item No.	Part No.	Description	Qty.
3-8		GAS BURNER ASSEMBLY	
1	SC01-084	. SCREW #10-32 X 3/8 HEX HD S	8
2	NS02-001	. NUT HEX KEPS #10-32 C.....	8
√ 3	88254	FLAME SENSOR- (AP1101001 & After).....	2
		Assembly's listed below do NOT include flame sensor	
√ 4	86940-001	ASSY- PILOT- LH NAT (AP1101001 & After)	1
√ 4	86940-002	ASSY- PILOT- RH NAT (AP1101001 & After)	1
√ 4	86940-003	ASSY- PILOT- LH LP (AP1101001 & After).....	1
√ 4	86940-004	ASSY- PILOT- RH LP (AP1101001 & After)	1
		For unit before above serial numbers, see KIT chart below	
5	54877	. ORIFICE, PILOT – NATURAL, CE NATURAL.....	2
5	60614	. ORIFICE, PILOT – LP, CE LP, PROPANE, BUTANE MIX.....	2
6	51735	. BURNER MOUNTING BRACKET	2
7	56708	. BRACKET- OBSOLETE- Use Kits listed below	2
8	FP05-010	. CONNECTOR, 3/8 TUBE TO 1/4 NPT	2
9	FP01-117	. STREET ELBOW, 1/4 NPT B.I.	2
10	14852	. KIT-GAS MANIFOLD	2
10	69919	. . GAS MANIFOLD.....	2
11	51725	. ORIFICE, BURNER – NATURAL	2
11	51730	. ORIFICE, BURNER – LP	2
11	55453	. ORIFICE, BURNER – CE LP	2
11	56219	. ORIFICE, BURNER – PROPANE/BUTANE MIX	2
11	40905	. ORIFICE, BURNER – LP BUTANE MIX 70% PRO 30% BU.	2
11	56637	. ORIFICE, BURNER – NATURAL JAPAN	2
12	52066	. BURNER INSHOT	4
13*	14221	. CONVERSION KIT – LP. TO NAT.	1
13*	14222	. CONVERSION KIT – NAT. TO LP.	1
13*	14269	. CONVERSION KIT – LP. TO NAT.-JAPAN	1
13*	14321	. CONVERSION KIT – LP. TO NAT.-CE	1
14*	14322	. CONVERSION KIT – NAT. TO LP.-CE	1

√ recommended parts

* not shown

Pilot Retrofit Kits		
Kit Number	Description	Qty.
140131	KIT- RETROFIT PILOT NAT W/ TUBES (before SN: AP0506015)	1
140095	KIT- RETROFIT- PILOT NAT (SN:AP0506015-AP1101001)	1
140132	KIT- RETROFIT- PILOT LP W/ TUBES (before SN: AP0506015)	1
140123	KIT- RETROFIT- PILOT LP (SN:AP0506015-AP1101001)	1

-All Retrofit kits include both right and left hand pilot assemblies and flame sensor

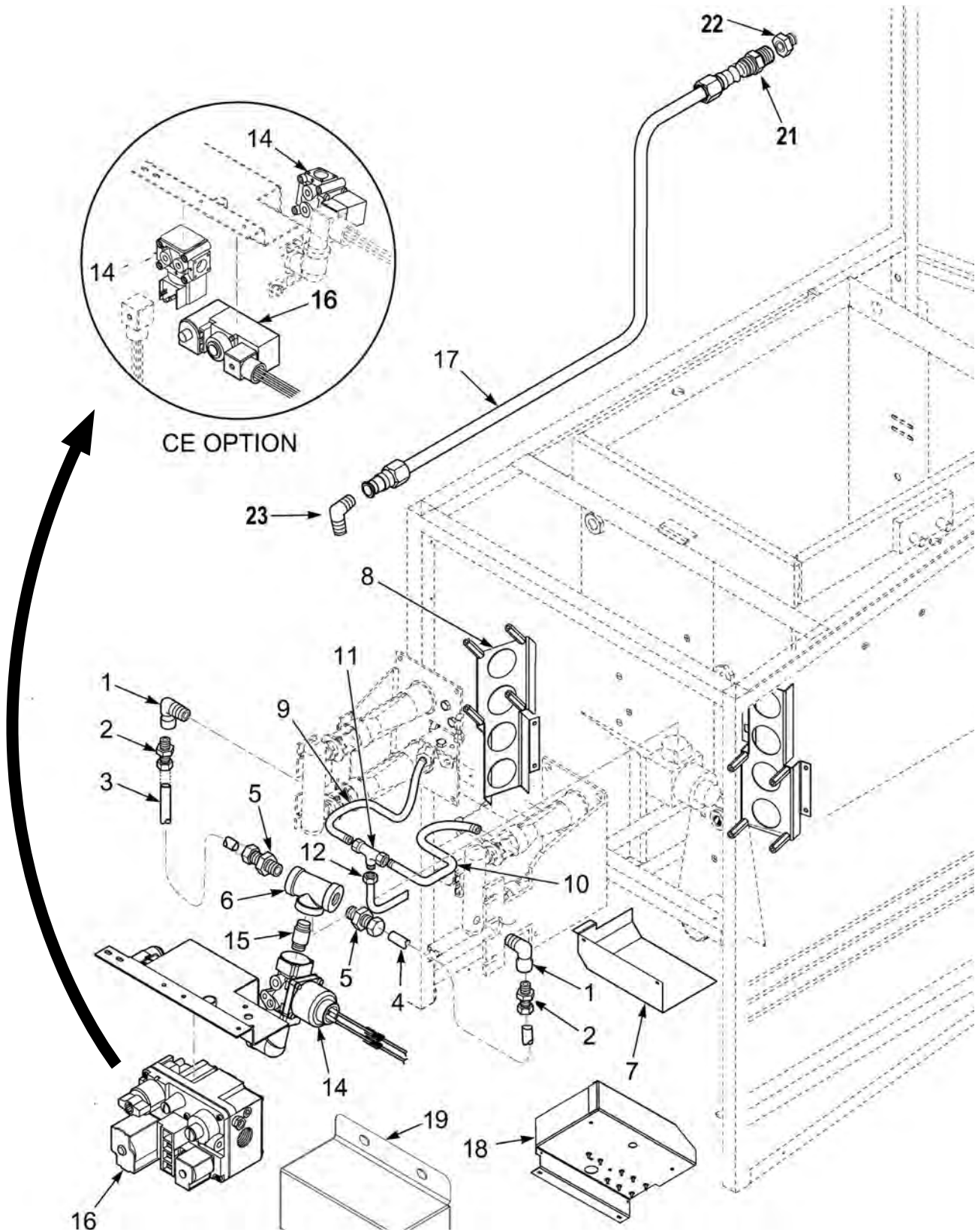

FIGURE 3-9. GAS PIPING & CONTROLS

Figure & Item No.	Part No.	Description	Qty.
3-9		GAS PIPING & CONTROLS	
1	FP01-117	ELBOW	2
2	FP05-010	FITTING 3/8 TUBE TO 1/4 NP	2
3	65173	MANIFOLD TUBE – LEFT	1
4	65173	MANIFOLD TUBE – RIGHT	1
5	FP01-115	NIPPLE – 3/8 to 1/2 NP.	2
6	FP01-112	1/2 NPT FEMALE PIPE TEE B.I.	1
7	54875	MODULE COVER.....	1
8	52785	BURNER SHIELD ASSY	2
	68536	BURNER SHIELD STUD ASSY	2
	51731	STANDOFF-BURNER	8
9	88227	PACK-SVCE LH PILOT TUBE.....	1
10	88228	PACK-SVCE RH PILOT TUBE	1
11	FP05-011	TEE – 1/4 X 1/4 X 1/4 BR COMPR.....	1
12	88228	PACK-SVCE RH PILOT TUBE	1
13*	21452	GAS VALVE ASSY 24V – CE – NATURAL GAS	1
		(includes 38402 & 14758)	
13*	21453	GAS VALVE ASSY 24V – CE – LP GAS	1
		(includes 38402 & 14759)	
√ 14	38468	. SOLENOID GAS VALVE – 24V 60 HZ (S/N IH024JJ & ABOVE) – NON CE.....	1
√ 14	34802	. SOLENOID GAS VALVE – 24V 50 HZ (S/N IH024JJ & ABOVE) – CE	2
15	FP01-028	. NIPPLE, CLOSE 1/2 NPT SS 1L.....	1
√ 16	80761	. COMBINATION GAS VALVE – NAT.- (S/N: AP0907006 & ABOVE)-NON CE (USED IN 52476).....	1
√ 16	80858	. COMBINATION GAS VALVE – LP.- (S/N: AP0907006 & ABOVE)NON CE	1
√ 16	140056	KIT, GAS VALVE, NAT/LP.- NON CE (S/N: AP0907005 AND BELOW) (KIT DOES NOT INCLUDE 38468 SOLENOID GAS VALVE)	1
16	140042	KIT. GAS VALVE, NAT/LP.- NON CE (S/N: AP0907005 AND BELOW) (KIT INCLUDES 38468 SOLENOID GAS VALVE)	1
√ 16	14758	. KIT-COMBINATION GAS VALVE-NAT– CE (USED IN 21452)	1
16	14759	. KIT-COMBINATION GAS VALVE-LP– CE (USED IN 21453)..	1
17	52122	MAIN GAS SUPPLY LINE ASSY	1
17	76333	MAIN GAS SUPPLY LINE ASSY - CE*S(BEFORE 4-22-2008)...	1
17	55433	MAIN GAS SUPPLY LINE ASSY - CE (AFTER 4-22-2008).....	1
18	59189	STUD ASSY - MODULE ENCLOSURE	1
19	51741	WIRE COVER - GAS VALVE (SN: AP0907005 & below).....	1
19	82232	COVER-GAS VALVE WIRE FRONT(SN: AP0907005 & after) ...	1
20*	FP01-200	FITTING - GAS INLET BSPT	1
21	16335	MALE CONNECTOR- 37° FLARE	1
22	FPO1-078	1/2IN TO 3/4IN REDUCER.....	1
23	16336	MALE ELBOW	1

√ recommended parts

* not shown

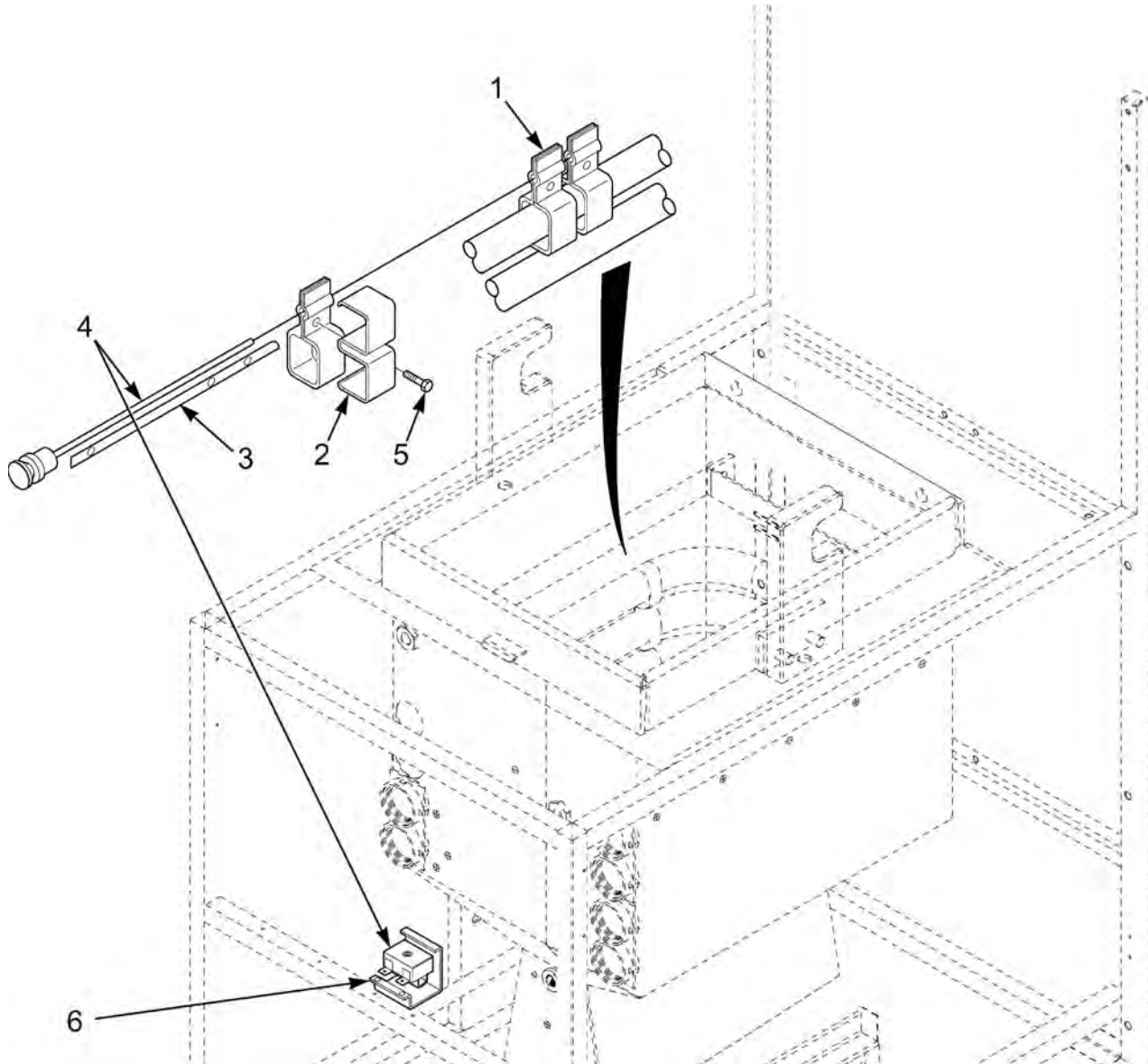

Figure & Item No.	Part No.	Description	Qty.
3-10		BURNER TUBES	
1	54480	BRACKET ASSY – HIGH LIMIT SENSING BULB.....	3
2	62051	CLIP – SPREADER – HEAT TUBE	6
3	53670	SPACER – HIGH LIMIT	1
√ 4	16738	450 HIGH LIMIT – NON CE	1
√ 4	60241	425 HIGH LIMIT – CE.....	1
5	SC01-211	SCREW #10-32 X 1/2 IND HEX HD S.S.	3
6	17216	BRACKET ASSY – HIGH LIMIT	1
7*	16268	THERMOCOUPLE FITTING - POT (for High Limit).....	1

√ recommended parts

* not shown

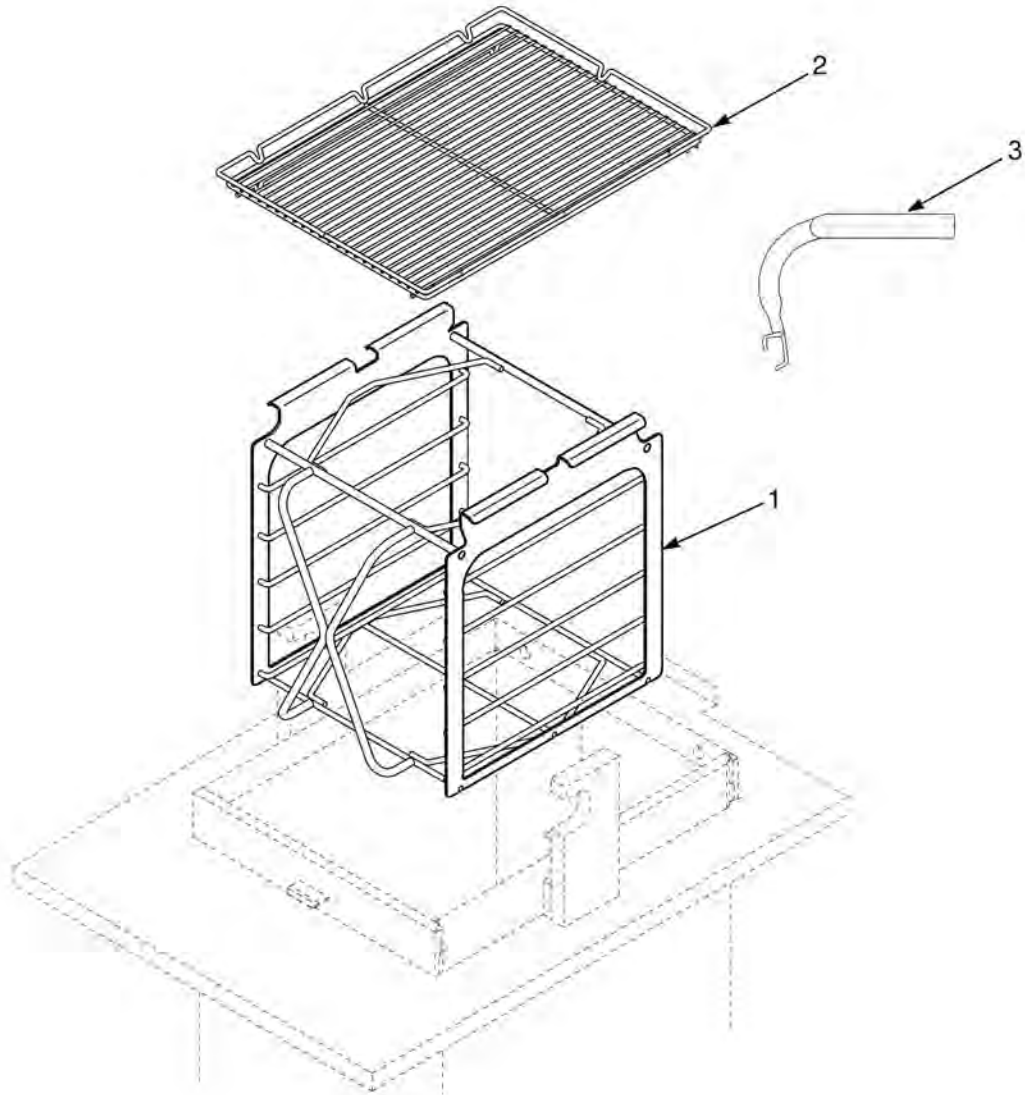

Figure & Item No.	Part No.	Description	Qty.
3-11		CARRIER & RACKS	
1	62183	CARRIER ASSY.....	1
2	44782	RACK HALF SIZE – 8 HEAD FRYER.....	5
3	35308	WELMENT - RACK HANDLE.....	1

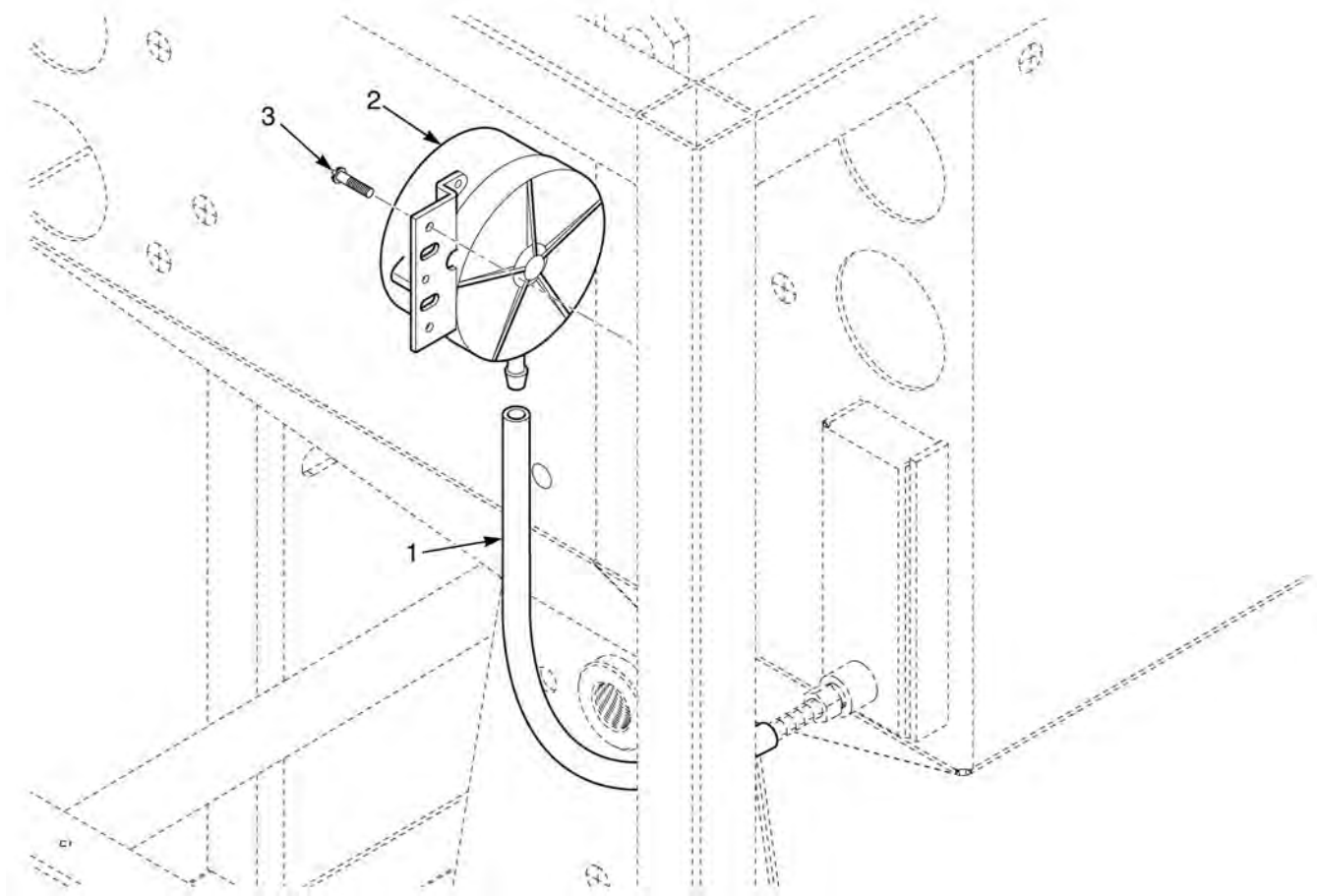
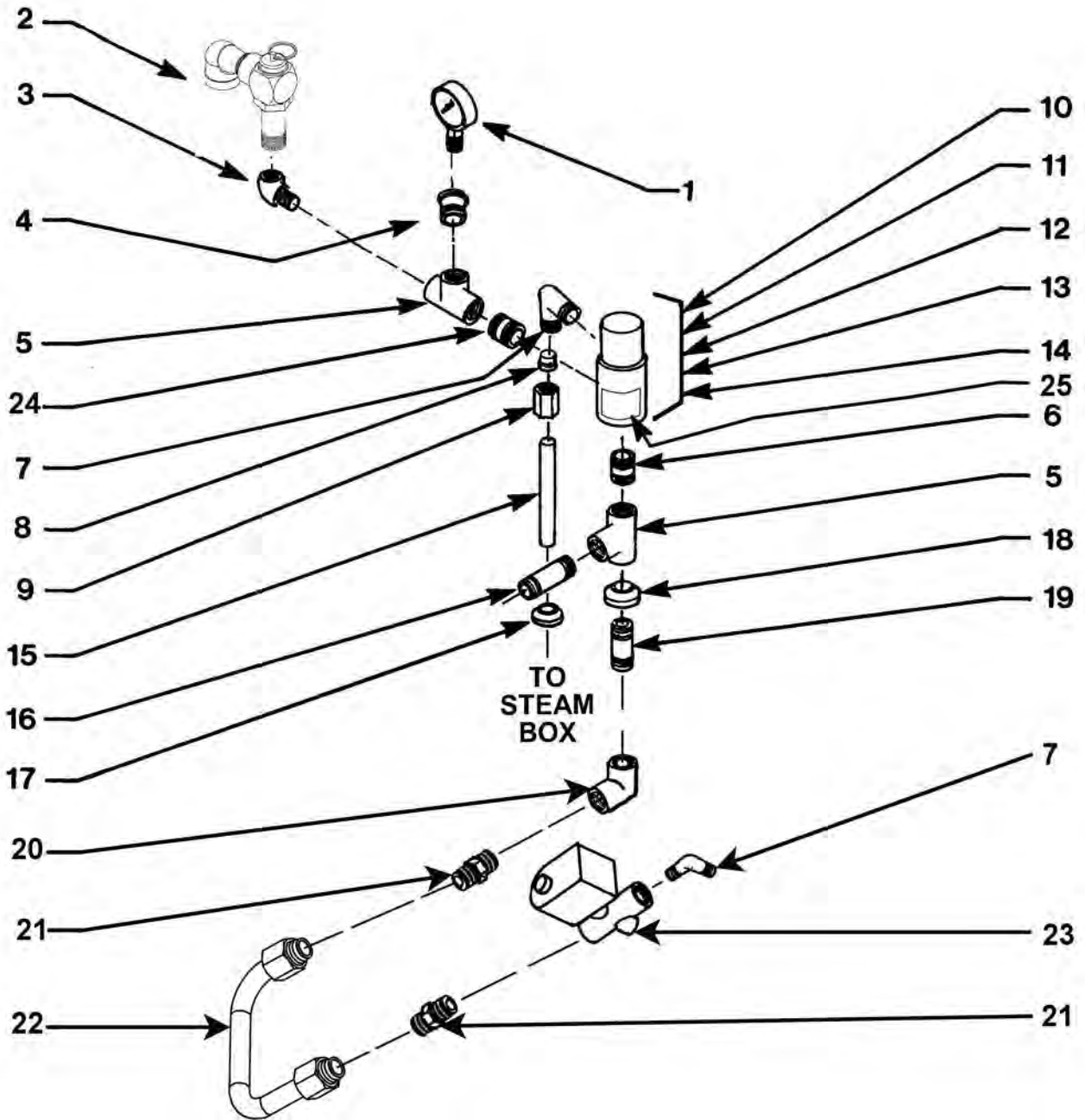

Figure & Item No.	Part No.	Description	Qty.
3-12		VACUUM SWITCH	
1	60202	TUBE-VACUUM SWITCH.....	1
√ 2	14240	KIT - VACUUM SWITCH - VERTICAL.....	1
√ 2	72514	VACUUM SWITCH – VERTICAL (Included in 14240 Kit).....	1
√ 2	72515	VACUUM SWITCH–VERTICAL-CE (SN: AP080209 & ABOVE) (SN: AP080208 & BELOW use 72514)	1
3	SC03-005	SCREW (Included in 14240 Kit).....	3

√ recommended parts



3-13. DEADWEIGHT & SOLENOID ASSEMBLY
(SN: AP082029 & ABOVE)

Figure & Item No.	Part No.	Description	Qty.
3-13		DEADWEIGHT & SOLENOID ASSY (SN: AP082029 & ABOVE)	
√ 1	16910	PRESSURE GAUGE.....	1
√ 2	59742	RELIEF VALVE ASSY.....	1
3	FP01-127	ELBOW, STREET, ½ X ½, 90 DEGREE.....	1
4	FP01-063	REDUCER, ½ NPT M TO ¼ NPT F.....	1
5	FP01-011	PIPE TEE, ½ NPT 304 SS	2
6	FP01-028	NIPPLE, CLOSE ½ NPT.....	1
7	17407	CONNECTOR, ½ MALE ELBOW.....	3
8	16817	FITTING, SLEEVE TEFLON.....	As Required
9	16809	NUT FITTING.....	As Required
10	56307	CAP, DEAD WEIGHT	1
11	16902	SEAL "O" RING	1
12	16903	DEADWEIGHT - 12 PSI.....	1
12	65449	DEADWEIGHT - 3 PSI.....	1
12	32729	DEADWEIGHT - 7 PSI.....	1
13	16918	ORIFICE, 12 PSI	1
14	56305	BODY, VALVE	1
15	35686	TUBE, DW TO EXHAUST STACK.....	1
16	35817	PIPE NIPPLE, ½ X 2 ¼ SS	1
17	16804	UMBRELLA GROMMET	1
18	35200	UMBRELLA GROMMET	1
19	35474	PIPE NIPPLE, ½ X 2.....	1
20	FP01-090	COUPLING, ½ NPT SS	1
21	16807	FITTING CONNECTOR, MALE	1
22	70475	TUBE, CONDENSATION	1
23	17121	VALVE, SOLENOID 120V, 60 Hz (See figure 3-17)	1
23	18721	VALVE, SOLENOID 208-240V, 60 Hz (See figure 3-17).....	1
23	18724	VALVE, SOLENOID 208-240V, 50 Hz (See figure 3-17).....	1
24	35856	NIPPLE, 1-1/8", SHORT, HOSPITAL	1
25	16912	DECAL-DEADWEIGHT ASSEMBLY	1

√ recommended parts

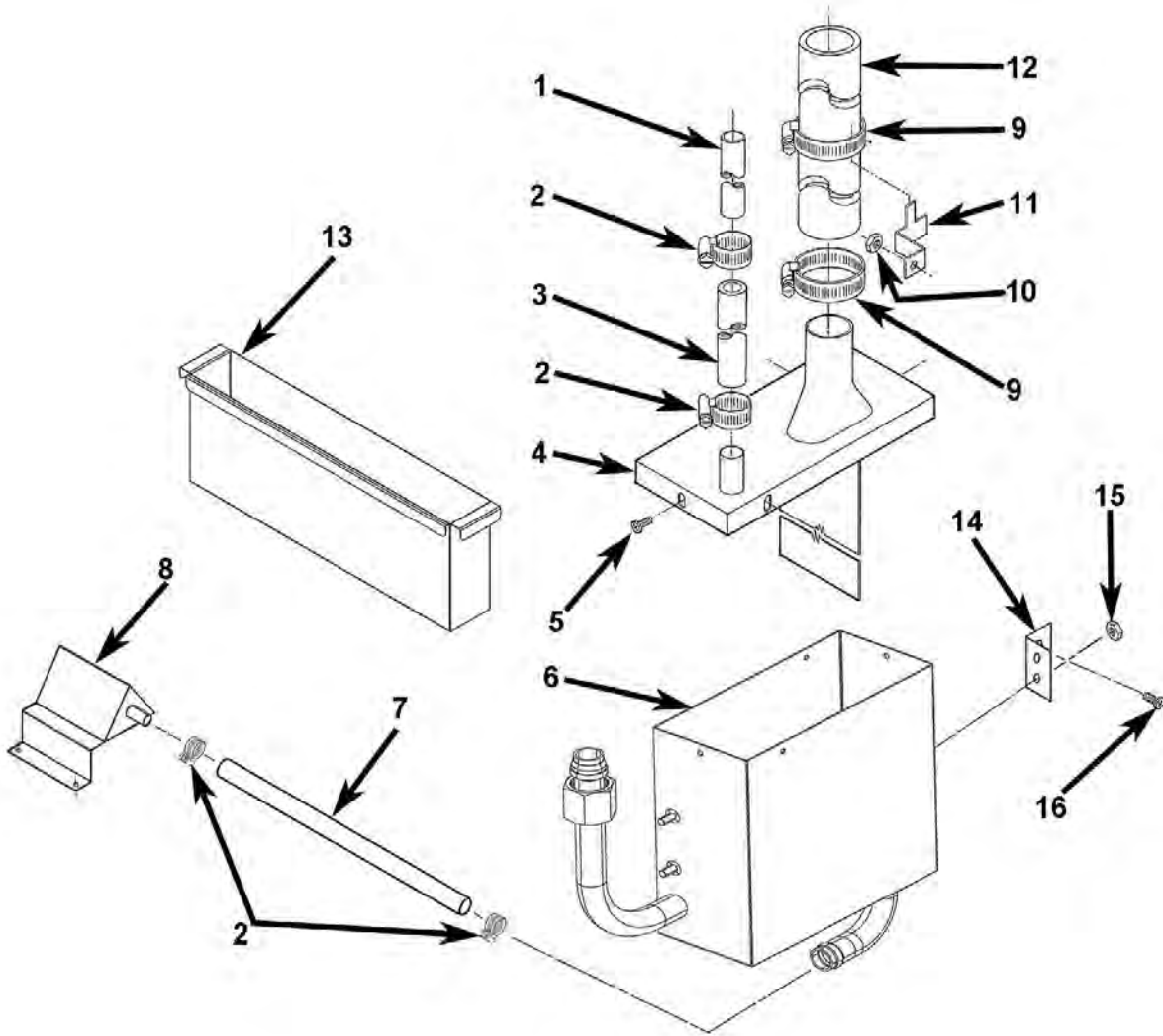

Figure & Item No.	Part No.	Description	Qty.
3-14A		STEAM BOX & HOSE ASSY (SN: AP082029 & UP)	
1	35686	TUBE, DW TO EXHAUST STACK SS.....	1
2	MS01-297	HOSE CLAMP, SS - .500 – 1.062 DID	4
3	70569	TUBE, EXHAUST CONNECT	1
4	35696	WELDMENT, STEAM EXHAUST BOX LID	1
5	SC02-041	SCREW, #8-18 X 7/16 PH IND XTRNL TRX	4
6	70523	WELDMENT, STEAM EXHAUST BOX.....	1
7	82516	HOSE, CONDENSATE	1
8	69263	RESTRICTOR	1
9	MS01-315	HOSE CLAMP, ½ X 1-3/4 SS	2
10	NS01-011	NUT, (#10-32 HEX).....	1
11	36851	BRACKET, HOSE	1
12	21877	TUBING, STEAM EXHAUST.....	4
13	71409	CONDENSATE PAN WELDMENT	1
14	70471	BRACKET	2
15	NS02-006	NUT.....	4
16	SC03-010	SCREW	4

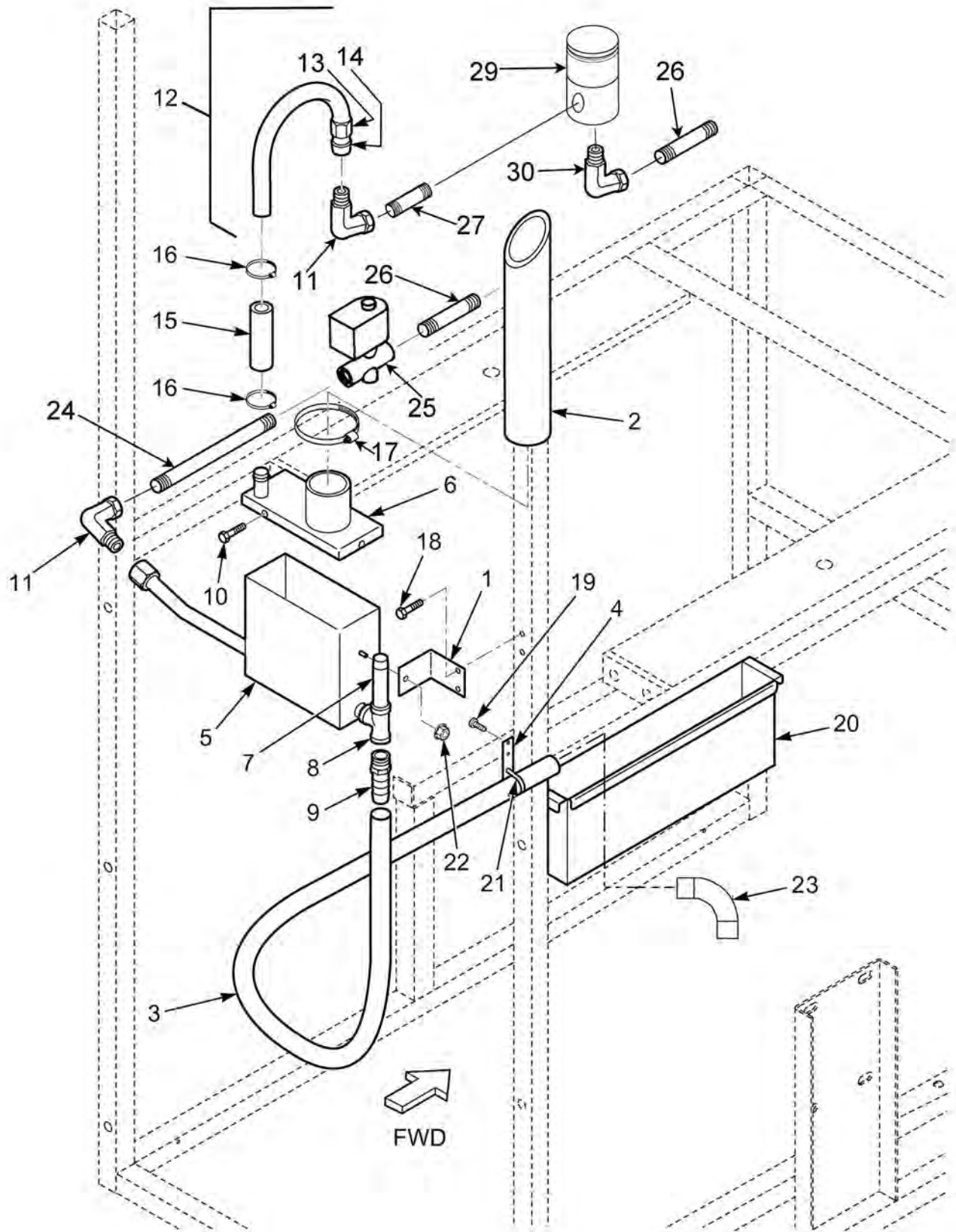
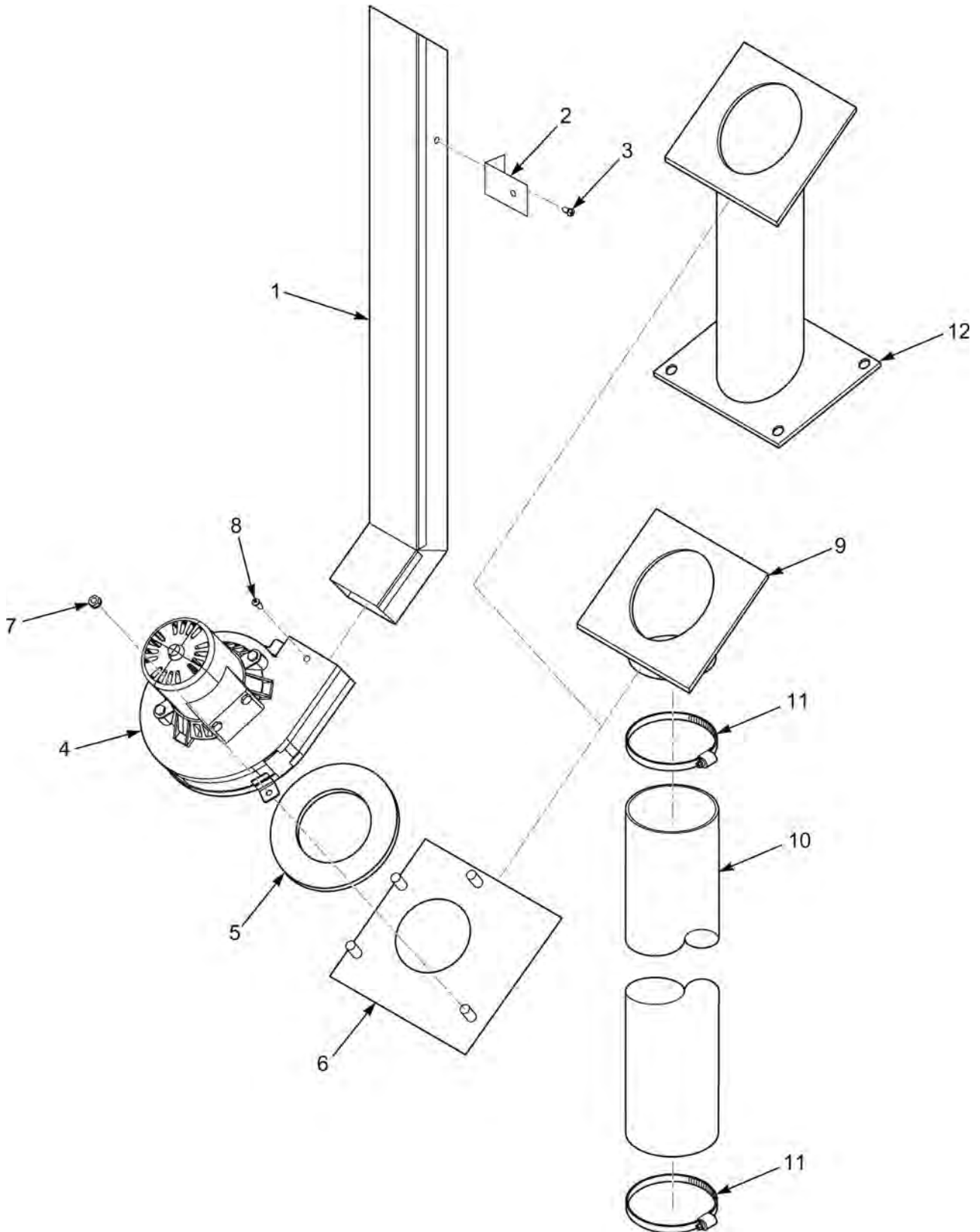

FIGURE 3-14B. STEAM BOX & HOSE ASSEMBLY
SN: AP0802028 & BELOW

Figure & Item No.	Part No.	Description	Qty.
3-14B		STEAM BOX & HOSE ASSEMBLY (SN: AP0802028 & BELOW)	
1	56335	BRACKET – CONDENSATE BOX.....	1
2	21878	TUBING – STEAM EXHAUST.....	1
2	42508	TUBING – STEAM EXHAUST-UNITS BUILT BEFORE 8/98	1
3	51748	CONDENSATE DRAIN HOSE.....	1
4	52056	CONDENSATION HOSE BRACKET	3
5	56312	CONDENSATE BOX – WELDMENT(S/N CH051II to AP0802028) (Includes items 6, 7, 8, 9, and 10)	1
5	52104	CONDENSATE BOX – WELDMENT (S/N CH050II & LOWER) ..	1
6	52108	ASSY – CONDENSATE BOX TOP	1
7	FP02-030	NIPPLE – 3/8 NPT X 3” LG BI.....	1
8	FP01-121	TEE – 3/8 NPT FEMALE N1	1
9	FP01-120	FITTING – 3/8 NPT BARB M BRASS.....	1
10	SC02-041	#8-32 X 7/16 PH IND XTRNL TRX	4
11	FP01-118	ELBOW – 5/8 TUBE – 1/2 NPT FEMALE.....	2
12	52185	ASSY – DEADWEIGHT/STEAM TUBE	1
13	16809	. NUT FITTING	1
14	16808	. SLEEVE FITTING.....	1
15	52124	DEADWEIGHT TO EXHAUST HOSE.....	1
16	MS01-297	HOSE CLAMP – SS .562-1.062 D1D	2
17	MS01-307	HOSE CLAMP 2-1/2–3 IN. SS.....	1
18	SC03-010	SCREW 1/4-20 X 3/4 HEX HD GS.....	2
19	SC03-005	SCREW	2
20	71409	CONDENSATE PAN	1
21	EF02-037	CLAMP 1 ID X 1/2 WD	1
22	NS02-006	NUT.....	1
23	68534	ELBOW - 5/8 CONDENSATION DRAIN.....	1
24	FP02-020	NIPPLE - 1/2 NPT X 5”.....	1
25	17121	VALVE, SOLENOID 120V, 60 Hz (See figure 3-17).....	1
25	18721	VALVE, SOLENOID 208-240V, 60 Hz (See figure 3-17).....	1
25	18724	VALVE, SOLENOID 208-240V, 50 Hz (See figure 3-17).....	1
26	16226	NIPPLE - 1/2 X 3-1/2”	2
27	35474	NIPPLE - 1/2 X 2 (SN: IH066JJ & BELOW)	1
27	FP01-061	NIPPLE - 1/2 X 2-1/2 SS (SN: IH067JJ & ABOVE)	1
28*	FP01-029	REDUCER - 1/2 NPTM-3/8 NPTFS (SN: IH066JJ & BELOW).....	1
29	-----	ASSY, DEADWEIGHT (See figure 3-13)	1
30	16239	STREET ELL 1/2 X 90 DEGREE	1

* not shown



**FIGURE 3-15. FLUE ASSEMBLY & BLOWER
SN: AP0802028 & BELOW**

Figure & Item No.	Part No.	Description	Qty.
3-15		FLUE ASSEMBLY & BLOWER (SN: AP0802028 & BELOW)	
1	55681	FLUE ASSY – WELDMENT	1
2	55783	BRACKET – FLUE RETAINING.....	1
3	SC03-005	SCREW SD #8 X 1/2 PH PHD.....	2
√ 4	14420	120V BLOWER – FLUE EXHAUST W/INSULATION.....	1
√ 4	14421	100V BLOWER – FLUE EXHAUST W/INSULATION.....	1
√ 4	14422	240V BLOWER – FLUE EXHAUST W/INSULATION.....	1
5	21329	. INSULATION – BLOWER.....	1
6	55673	STUD ASSY – BLOWER MOUNT PLATE.....	1
7	NS02-002	NUT KEPS 1/4-20 C.....	4
8	SC02-041	#8-32 X 7/16 PH IND XTRNL TRX.....	2
9	55675	ASSY – INSUL/BLOWER INLET-NAT GAS ONLY.....	1
10	52103	DILUTION HOSE/BLOWER-NAT GAS ONLY.....	1
11	MS01-429	HOSE CLAMP – 3 9/16-4 1/2 PL-NAT GAS ONLY.....	2
12	32743	DILUTION HOSE ASSEMBLY-LP GAS ONLY.....	1
13*	14384	KIT, FLUE DUCTS – BUTANE	1
14*	21980-1	DILUTION BOX ASSY - NAT- 3,999FT).....	1
14*	21980-2	DILUTION BOX ASSY - LP - CE (0-3,999 FT).....	1
14*	21980-3	DILUTION BOX ASSY - NAT. - CE (0-3,999 FT).....	1
14*	21980-4	DILUTION BOX ASSY - LP-CE (OVER 3,999 FT).....	1
14*	21980-5	DILUTION BOX ASSY - NAT.-CE (OVER 3,999 FT).....	1

√ recommended parts
 * not shown

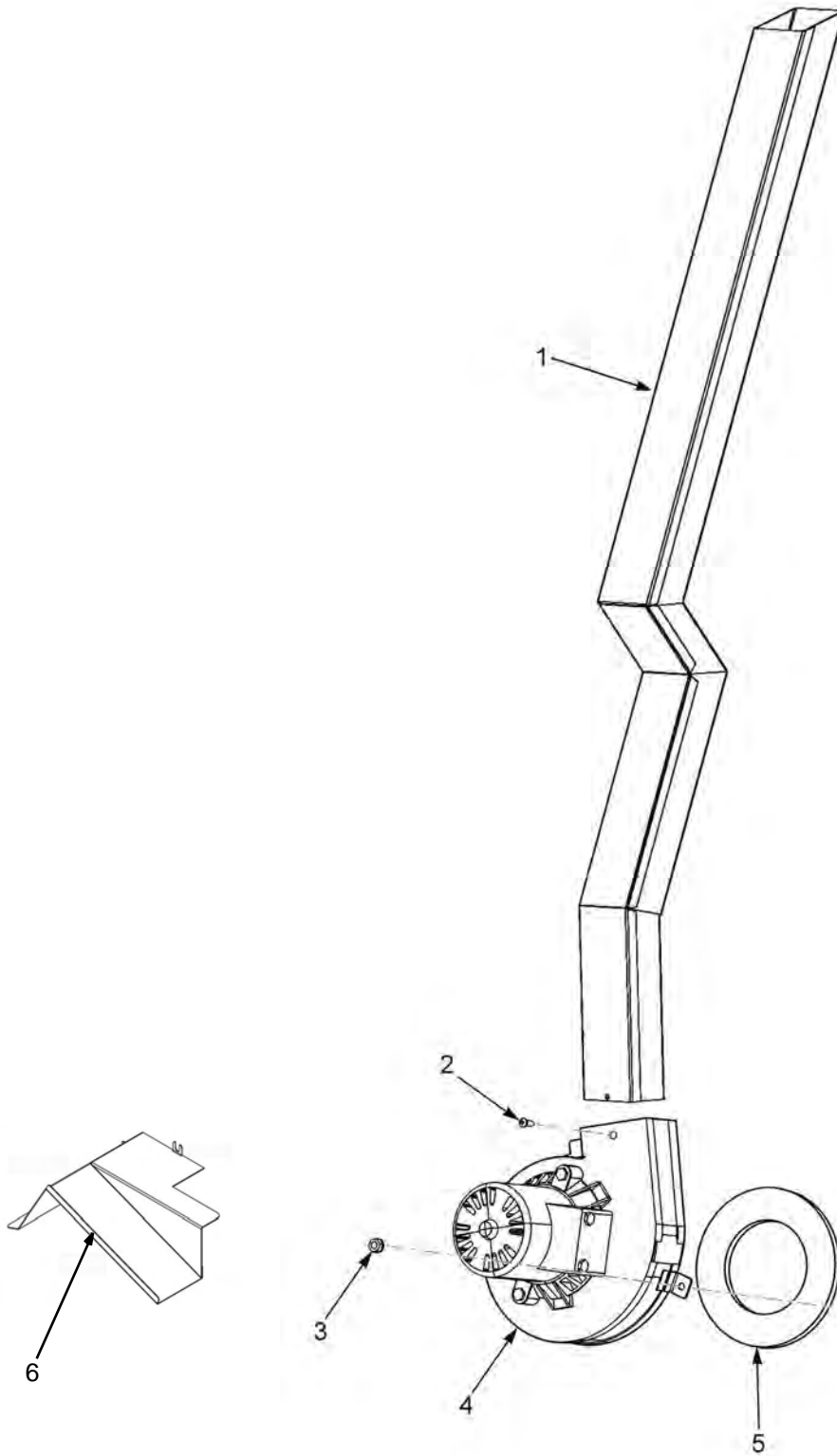

**FIGURE 3-16. FLUE ASSEMBLY & BLOWER
SN: AP080209 & ABOVE**

Figure & Item No.	Part No.	Description	Qty.
3-16		FLUE ASSEMBLY & BLOWER (SN: AP0802029 & ABOVE)	
1	70582	FLUE ASSY – WELDMENT	1
2	SC02-041	#8-32 X 7/16 PH IND XTRNL TRX	1
3	NS02-002	NUT KEPS 1/4-20 C.....	5
√ 4	14986	120V BLOWER – FLUE EXHAUST W/INSULATION.....	1
√ 4	14988	100V BLOWER – FLUE EXHAUST W/INSULATION.....	1
√ 4	14987	220 – 230V BLOWER – FLUE EXHAUST W/INSULATION....	1
√ 4	14422	240V BLOWER – FLUE EXHAUST W/INSULATION.....	1
5	21329	. INSULATION – BLOWER.....	1
6	84144	BLOWER DRIP SHIELD ASSY - WELDMENT.....	1

√ recommended parts

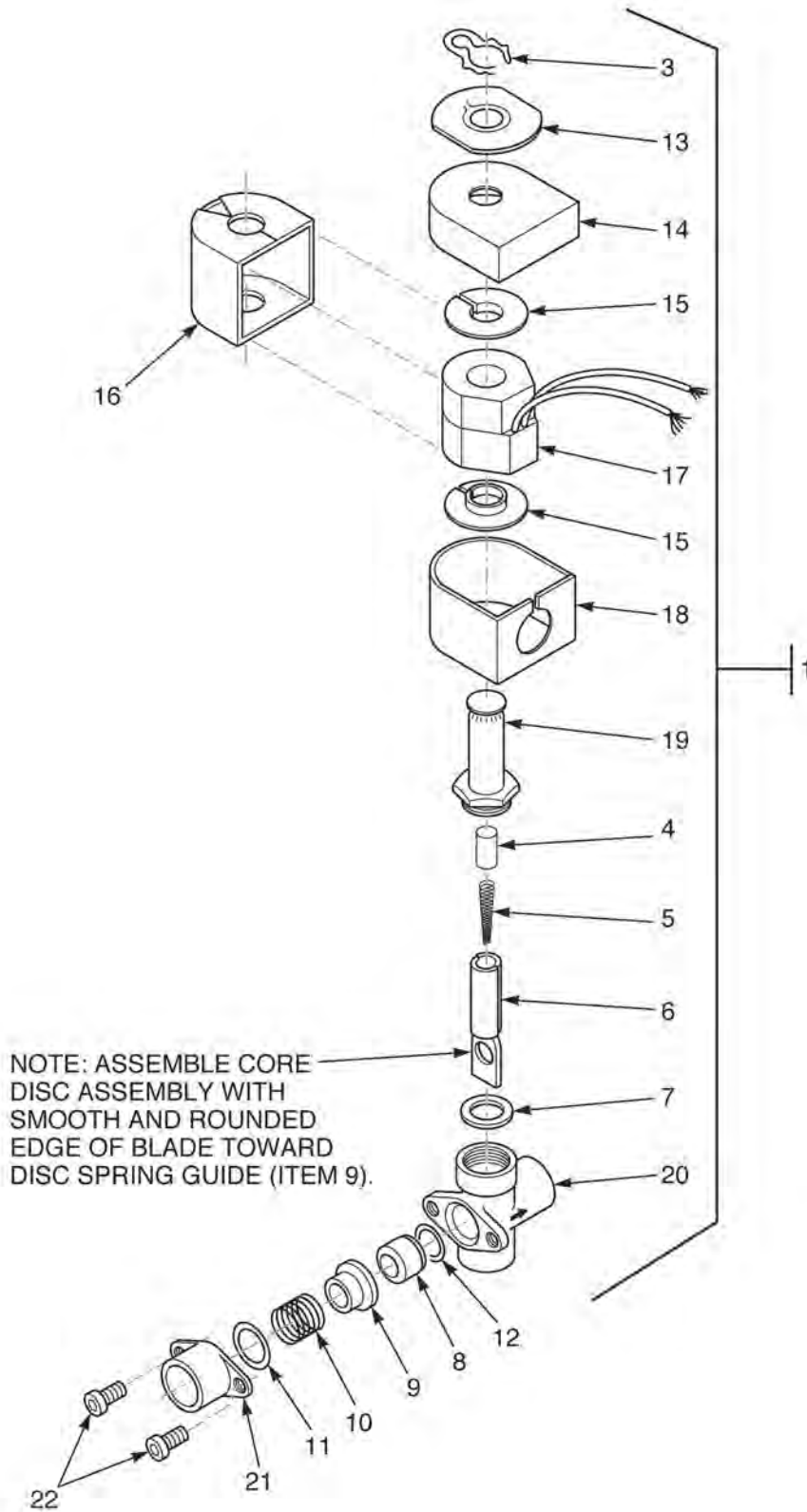

FIGURE 3-17. SOLENOID VALVE ASSEMBLY

Figure & Item No.	Part No.	Description	Qty.
3-17		SOLENOID VALVE ASSEMBLY	
1	17121	VALVE, SOLENOID 120V, 60 Hz	1
1	18721	VALVE, SOLENOID 208-240V, 60 Hz.....	1
1	18724	VALVE, SOLENOID 208-240V, 50 Hz.....	1
√ 2	17120	. KIT, SOLENOID VALVE REPAIR	1
3	17101	.. CLIP, RETAINER	1
4	17109	.. RETAINER, SPRING	1
5	17110	.. SPRING, CORE.....	1
6	17111	.. CORE, DISC ASSEMBLY	1
7	17112	.. GASKET, BONNET	1
8	17114	.. SEAT, TEFLON	1
9	17115	.. GUIDE, DISC SPRING	1
10	17116	.. SPRING, DISC	1
11	17117	.. RING, SPRING RETAINER	1
12	17122	.. SEAT, O-RING SEAL.....	1
13	17102	PLATE, SOLENOID NAME	1
√ 14	17103	COVER, COIL HOUSING	1
√ 15	17104	WASHER, COIL	2
√ 16	17105	YOKE, COIL	1
√ 17	17106	COIL, 120V, 60 Hz	1
√ 17	18706	COIL, 208-240V, 60 Hz.....	1
√ 17	18726	COIL, 208-240V, 50 Hz.....	1
√ 18	17123	HOUSING, COIL.....	1
√ 19	17108	BONNET, SOLENOID.....	1
√ 20	17113	BODY, SOLENOID VALVE	1
√ 21	17118	ADAPTER, PIPE	1
√ 22	SC01-132	SCREW, ADAPTER	2

√ recommended parts

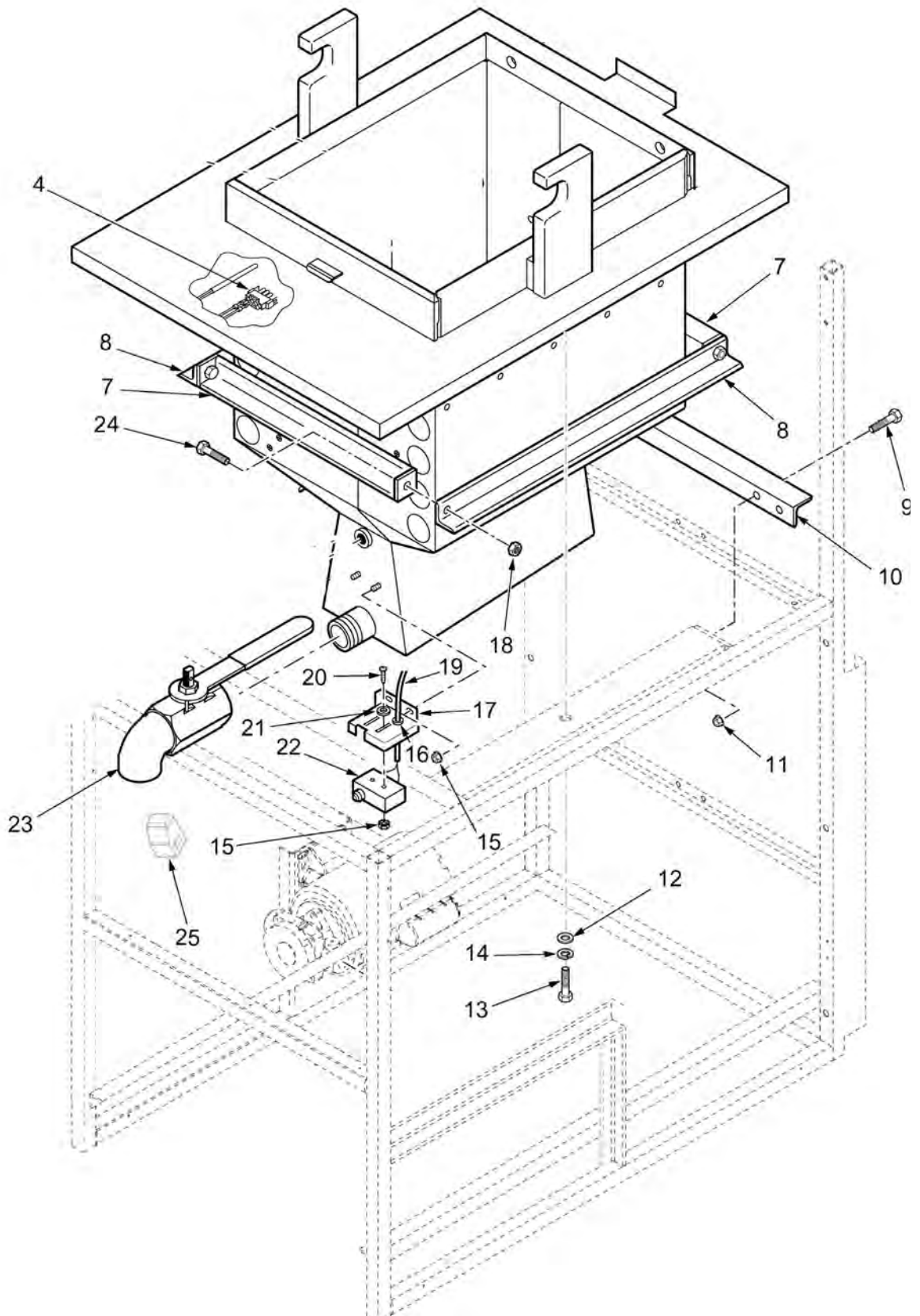
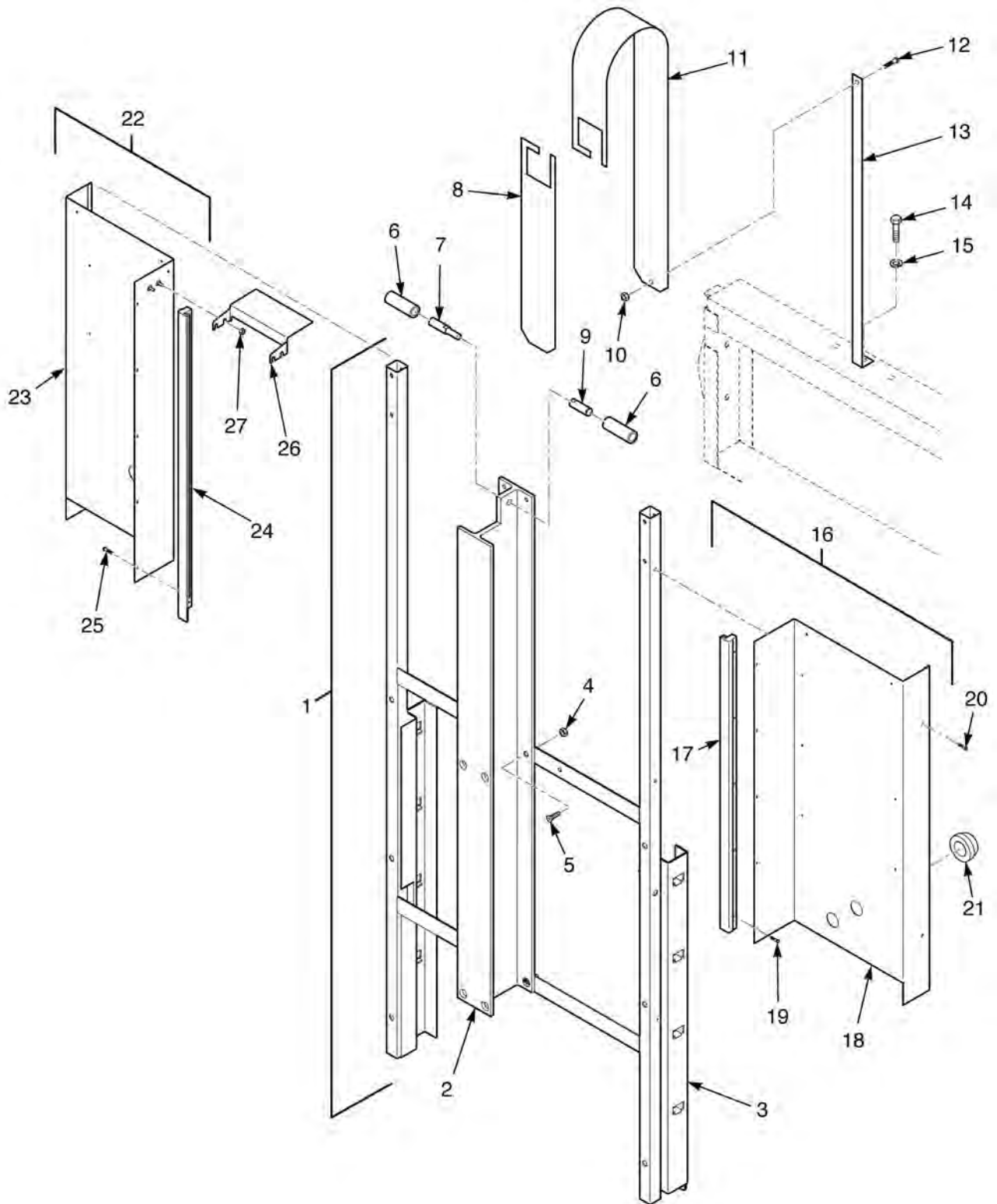

FIGURE 3-18. FRYPOT & DRAIN PIPING

Figure & Item No.	Part No.	Description	Qty.
3-18		FRYPOT & DRAIN PIPING	
√4	14330	PROBE ASSY – DOMESTIC	1
√4	14266	KIT-CE PROBE CONNECTOR RETROFIT (probe not included).. (CE units built prior to NOV. 1, 1999)	1
5	16226	NIPPLE 1/2 X 3-1/2	2
6	16239	ELBOW	1
7	51792	POT BRACE, FRONT AND REAR	2
8	51790	POT BRACE, SIDE.....	2
9	SC01-022	SCREW 1/4-20 X 3/4 HEX HD.	4
10	51874	SUPPORT, REAR.....	1
11	NS02-002	NUT 1/4-20.....	4
12	WA01-018	WASHER 3/8 FLAT	2
13	SC01-042	SCREW 3/8-16 X 1 HEX HD.	2
14	LW01-010	LOCKWASHER 3/8 SPLIT RING.....	2
15	NS02-005	NUT #6-32 HEX.....	4
16	EF02-017	STRAIN RELIEF	1
17	51891	BRACKET, SWITCH (SN: AP0403029 & BELOW).....	1
17	67618	BRACKET, SWITCH (SN: AP0403030 & ABOVE)	1
18	NS01-016	NUT 7/16-14 HEX.....	4
19	52519	CORD ASSY., DRAIN INTERLOCK	1
20	SC01-058	SCREW #6-32 X 1 PH. PAN HD.....	2
21	WA01-006	WASHER #6.....	2
√22	54228	DRAIN SWITCH W/BOOT.....	1
23	21355	DRAIN VALVE W/EXTENSION (BELOW SN: AP0401001).....	1
23	66446	DRAIN VALVE W/EXTENSION (SN: AP0401001 & ABOVE)	1
24	SC01-217	SCREW 7/16-14 X 1-1/4 HEX HD.....	4
25	67617	BRACKET - MICROSWITCH TRIGGERING..... (SN: AP0802028 & BELOW)	1
26*	76683	PLATE - D/I SWITCH COVER GAS.....	1

√ recommended parts



**FIGURE 3-19. LIFT BEAM & SHROUDS
SN: AP0802028 & BELOW**

Figure & Item No.	Part No.	Description	Qty.
3-19		LIFT BEAM & SHROUDS (SN: AP0802028 & BELOW)	
1	55678	ASSY – I-BEAM/LIFT FRAME	1
2	51548	. LIFT I-BEAM	1
3	55677	. LIFT FRAME ASSY – WELDMENT	1
4	NS02-008	. . NUT.....	4
5	SC01-212	. . SCREW	4
6	52474	STOP - LIFT U-CHANNEL	1
7	51595	STOP PIN MALE	1
8	56825	LIFT STRAP FILLER – LOWER	1
9	51594	STOP PIN – FEMALE.....	1
10	NS02-007	NUT.....	1
11	56824	LIFT STRAP FILLER – UPPER	1
12	SC01-034	SCREW – PH.....	1
13	52177	LIFT STRAP	1
14	SC01-052	BOLT.....	1
15	LW01-002	LOCK WASHER	1
16	52784	ASSY – FRONT SHROUD/RIGHT	1
17	21345	. SLIDE GUIDE – RIGHT	1
18	52482	. WELDMENT – FRONT SHROUD/RIGHT	1
19	SC01-023	. SCREW #6-32 X 1/4 PH RHD C	5
20	SC03-005	SCREW – PH.....	4
21	16804	UMBRELLA GROMMET.....	3
22	52521	ASSY – FRONT SHROUD/LEFT.....	1
23	62087	. ASSY – FRONT SHROUD, LEFT STUD	1
24	21346	. SLIDE GUIDE – LEFT	1
25	SC01-023	. SCREW #6-32 X 1/4 PH RHD C	5
26	62091	SHROUD SPACER/PULLY GUARD.....	1
27	NS02-005	NUT.....	4
28*	14218	SINGLE TO DOUBLE LIFT STRAP KIT.....	1

* not shown

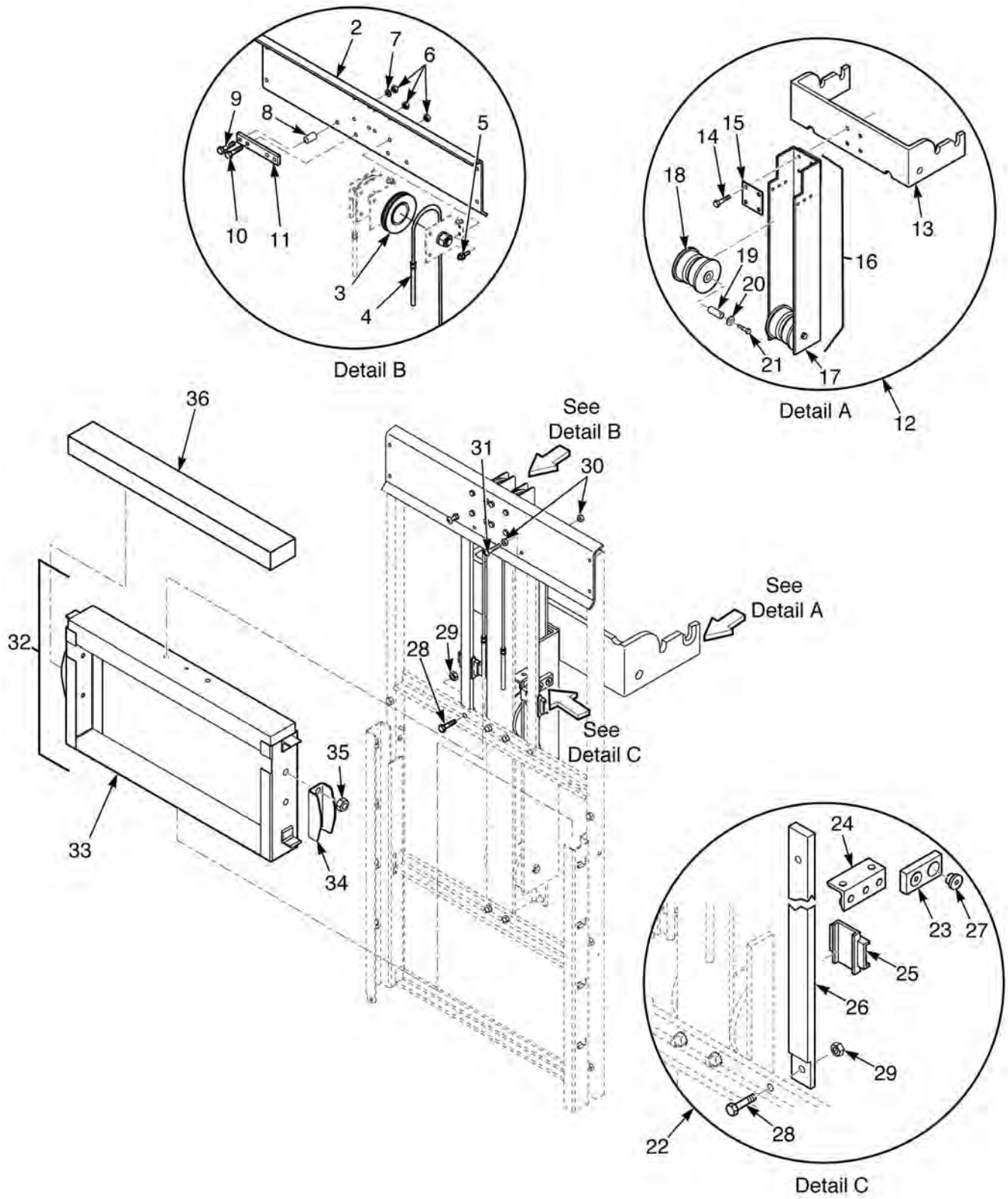

**FIGURE 3-20. COUNTERWEIGHT & PULLEY SYSTEM
(SN: AP080208 & BELOW)**

Figure & Item No.	Part No.	Description	Qty.
3-20		COUNTERWEIGHT & PULLEY SYSTEM (SN: AP0802028 & BELOW)	
2	51677	PULLEY PLATE.....	1
3	35962	BRACKET/WHEEL ASSY	2
√ 4	140225	KIT-CABLE (2 CABLES).....	1
5	SC01-022	SCREW 1/4-20 X 3/4 HEX HD C.....	8
6	NS02-002	NUT KEPS 1/4-20 C.....	12
7	WA01-002	WASHER	2
8	51590	SPACER.....	2
9	SC01-104	BOLT.....	2
10	SC01-022	BOLT.....	2
11	51591	I BEAM – PULLEY BRACE	1
12	54494	ASSY – LID ARM/U-CHANNEL.....	1
13	51692	. MACHINED – ARM – LID LIFT	1
14	55883	. SCREW 3/8–16 X 1-1/2 FT HH G	4
15	55598	. TORQUE PLATE – U-CHANNEL	1
16	54493	. ASSY – LIFT U-CHANNEL	1
17	51549	. . LIFT U-CHANNEL	1
18	66715	. . WHEEL – TRUCK	4
19	51593	. . SPINDLE – U CHANNEL WHEEL.....	4
20	LW01-001	. . LOCKWASHER SPLIT RING 3/8 ID.....	4
21	SC01-081	. . SCREW 3/8-24 X 3/4 HEX HD S	4
22	55873	STABILIZER COMPONENTS – ASSY	1
23	59113	. SUPPORT ARM – STABILIZER	2
24	51553	. ASSY – CABLE MOUNTING BRACKET	2
25	59112	. SLIDE – STABILIZER.....	2
26	59111	. BRACE – STABILIZER.....	2
27	SC01-226	. 5/16-18 X 1-1/4 FHD CAP SCREW.....	6
28	SC01-146	. SCREW 1/4-20 X 3/4 HEX HD C.....	2
29	NS02-002	. NUT KEPS 1/4-20 C.....	4
30	NS01-012	. NUT HEX 1/4-20 C	2
31	SC01-232	. 1/4-20 X 2.00 TRUSS HD PH ZI	2
32	54492	ASSY – CARRIAGE, WEIGHT.....	1
33	52118	. ASSY – WEIGHT BRACKET, STUD	1
34	62018	. GUIDE – COUNTER WEIGHT.....	2
35	NS02-002	. NUT KEPS 1/4-20 C.....	4
36	36627	COUNTERWEIGHT BAR	7

√ recommended parts

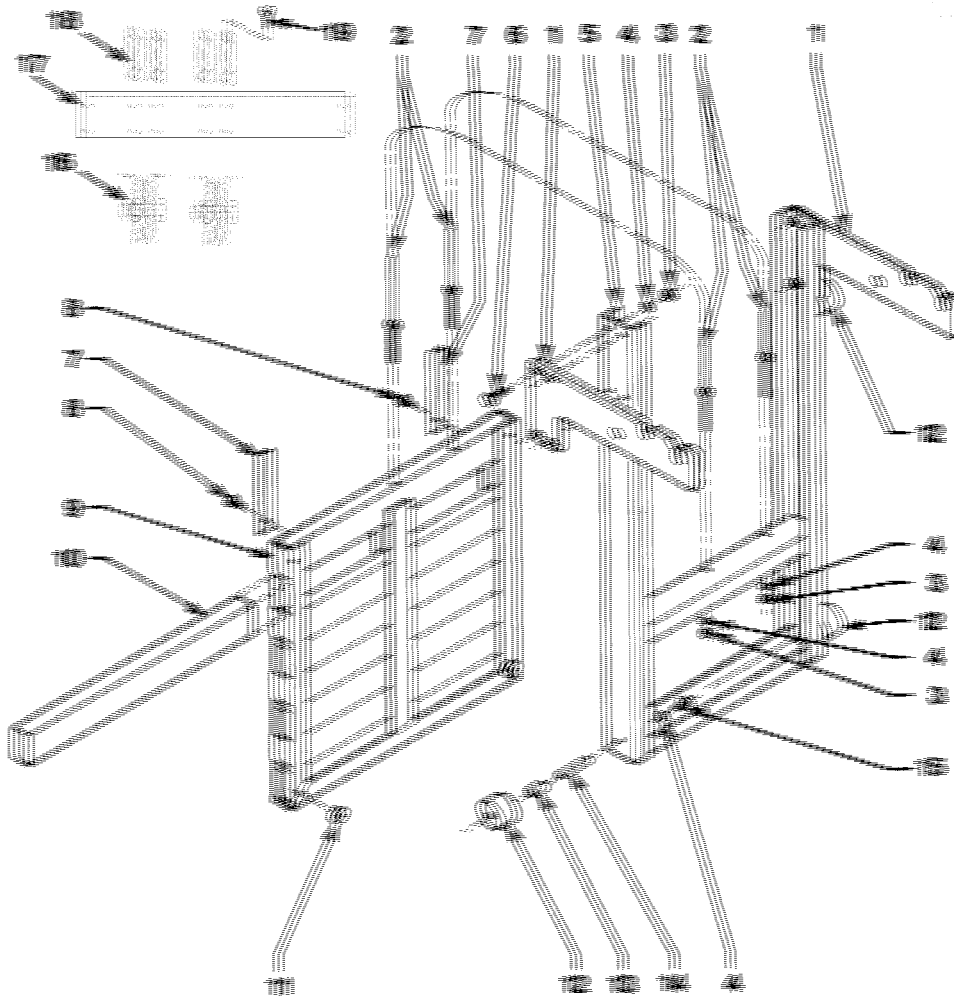

Figure & Item No.	Part No.	Description	Qty.
3-21		COUNTERWEIGHT SYSTEM (SN: AP0802029 & ABOVE)	
1	35026	ARM, LID SUPPORT.....	2
√ 2	140225	KIT-CABLE (2 CABLES).....	1
3	NS01-025	NUT, HEX 5/16-18 SS.....	10
4	LW01-010	WASHER, 3/8 SPLIT RING SS.....	10
5	35092	CARRIAGE.....	1
6	SC01-069	SCREW, 3/8-16 X 1-1/2 HEX HD S2P.....	8
7	36839	SLIDE.....	2
8	SC01-042	SCREW, 3/8-16 X 1 HEX C.....	2
9	36625	WELD ASSEMBLY, C/W CARRIAGE.....	1
10	36627	COUNTERWEIGHT BAR.....	7
11	36626	SPACER, C/W FRAME.....	2
12	37362	WHEEL, CARRIAGE.....	4
13	37363	SPACER, CARRIAGE WHEEL.....	4
14	37364	SPINDLE.....	4
15	SC01-081	SCREW, 3/8-24 X 3/4 HEX HD SS.....	4
16	35962	BRACKET/WHEEL ASSY.....	2
17	36561	BRACE, TOP FRAME.....	1
18	35954	PLATE, SUPPORT PULLEY.....	4
19	SC01-132	1/2-20 X 5/8 SOC HD CAP SCREW.....	8

√ recommended parts

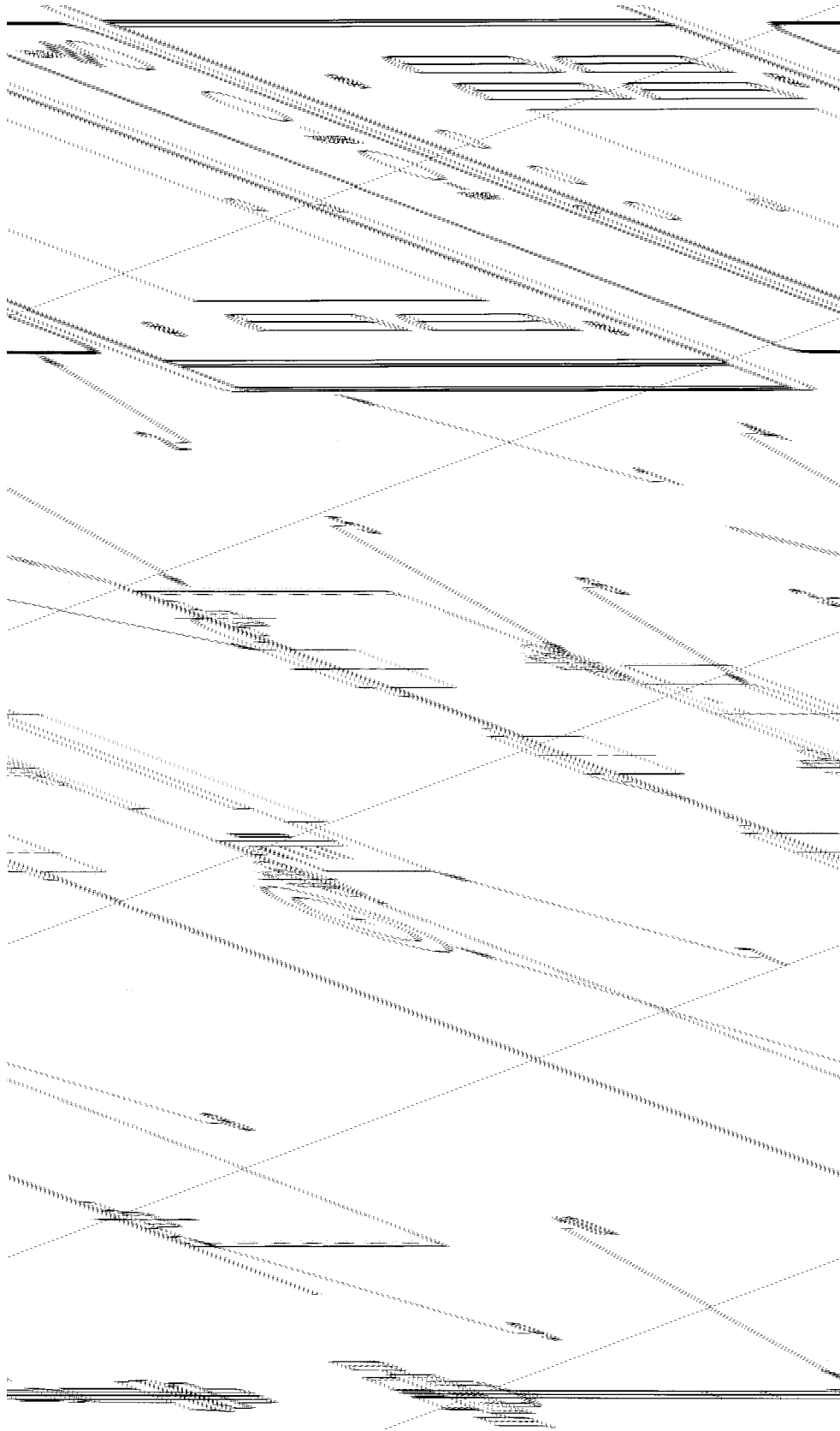

Figure 3-22. FAST Ready Parts

Figure & Item No.	Part No.	Description	Qty.
3-22		FAST READY PARTS	
1	66287	ASSY - 392/692 - 120V FAST HEADER.....	1
1	66288	ASSY - 392/692 - 230V FAST HEADER - CE.....	1
1	66385	ASSY - 392/692 - 220-240V FAST HEADER.....	1
1	66241	STUD ASSY - 392/692 CONTROL PNL	1
1	66296	STUD ASSY - 392/692 CONTROL PNL - CE.....	1
2	66289	DECAL - 392/692 FAST CONTROL.....	1
2	66294	DECAL - 392/692 FAST - CE CONTROL.....	1
√ 3	54085	LIGHT - CE INDICATOR, GREEN - CE.....	2
√ 3	16624	LIGHT - INDICATOR, RED.....	3
4	66239	BOX - SHIELD - 392/692.....	1
4	66302	BOX - SHIELD - 392/692 - CE	1
5	SC01-023	SCREW - #6-32 X 1/4 PH RHD C.....	11
√ 6	81914	(REPLACES 54472)POWER RELAY - 15A-120VAC ..	1
√ 6	56394	POWER RELAY - 10A-240VAC-DBL POLE.....	1
√ 6	60818	RELAY - 24VAC COIL (NON-CE)	3
√ 7	66259	ASSY - 120V FAST TRANSFORMER	1
7	66261	ASSY - 230V FAST TRANSFORMER	1
8	EF02-072	BUSHING SPLIT 3/4.....	1
9	NS02-005	NUT HEX KEPS #6-32 C	11
√ 10	66244	ASSY - FAST 392/692 PROBE	1
√ 11*	66260	BOARD - 230V FAST I/O CONTROL - CE	1

√ recommended parts

* not shown