



**Henny Penny  
Rotisserie Display  
Model SCD-6/8**

**TECHNICAL MANUAL**



## TABLE OF CONTENTS

<b>Section</b>		<b>Page</b>
Section 1.	TROUBLESHOOTING .....	1-1
	1-1. Introduction .....	1-1
	1-2. Safety .....	1-1
	1-3. Troubleshooting .....	1-1
	1-4. Error Codes .....	1-3
Section 2.	MAINTENANCE .....	2-1
	2-1. Introduction .....	2-1
	2-2. Maintenance Hints .....	2-1
	2-3. Light Bulb Replacement .....	2-1
	2-4. Blower Replacement .....	2-2
	2-5. Thermal Sensor Replacement .....	2-3
	2-6. Light Fixture Replacement .....	2-4
	2-7. Power Switch .....	2-4
	2-8. Heaters .....	2-5
	2-9. Relays .....	2-7
	2-10. Control Board Replacement .....	2-9
	2-11. Transformer Replacement .....	2-10
	2-12. High Limit Replacement .....	2-11
	2-13. Wiring Diagram .....	2-12
Section 3.	PARTS INFORMATION .....	3-1
	3-1. Introduction .....	3-1
	3-2. Genuine Parts .....	3-1
	3-3. How To Order .....	3-1
	3-4. Prices .....	3-1
	3-5. Delivery .....	3-1
	3-6. Warranty .....	3-1
	3-7. Recommended Spare Parts for Distributors .....	3-1

## SECTION 1. TROUBLESHOOTING

### 1-1. INTRODUCTION

This section provides troubleshooting information in the form of an easy to read table.

If a problem occurs during the first operation of a new rotisserie merchandiser, recheck the installation per the Installation Section of the Operator's Manual.

Before troubleshooting, always recheck the Operation Section of the Operator's Manual.

### 1-2. SAFETY

Where information is of particular importance or is safety related, the words NOTICE, CAUTION, or WARNING are used. Their usage is described below.



**SAFETY ALERT SYMBOL** is used with **DANGER**, **WARNING**, or **CAUTION** which indicates a personal injury type hazard.

**NOTICE** is used to highlight especially important information.

*CAUTION used without the safety alert symbol indicates a potentially hazardous situation which, if not avoided, may result in property damage.*

*CAUTION indicates a potentially hazardous situation which, if not avoided, may result in minor or moderate injury.*

**The word WARNING is used to alert you to a procedure, that if not performed properly, might cause personal injury.**

### 1-3. TROUBLESHOOTING

To isolate a malfunction proceed as follows:

1. Clearly define the problem or symptom and when it occurs.
2. Locate the problem in the troubleshooting table.
3. Review all possible causes, then one at a time work through the list of corrections until the problem is solved.



**If maintenance procedures are not followed correctly, injuries and/or property damage could result.**

**1-3. TROUBLESHOOTING (Continued)**

Problem	Cause	Correction
<b>POWER SECTION</b>		
<p>With power switch in POWER position the merchandiser is completely inoperative</p>	<ul style="list-style-type: none"> <li>• Open circuit</li> </ul>	<ul style="list-style-type: none"> <li>• Check to see that unit is plugged in</li> <li>• Check the breaker or fuse at supply box</li> <li>• Check voltage at wall receptacle</li> <li>• Check power switch; replace if defective</li> <li>• Check cord and plug</li> </ul>
<p>Unit will not heat</p>	<ul style="list-style-type: none"> <li>• Blown fuse or tripped circuit breaker at supply box</li> <li>• Blown fuse PC board</li> <li>• Faulty power switch</li> <li>• Faulty PC Board</li> <li>• Faulty cord and plug</li> <li>• Faulty relay</li> </ul>	<ul style="list-style-type: none"> <li>• Reset breaker or replace fuse</li> <li>• Check 1.5 amp fuse on PC board</li> <li>• Check power switch per Power Switch Section</li> <li>• Remove and replace control board</li> <li>• Check cord and plug and power at wall receptacle</li> <li>• Check relay per Relays Section</li> </ul>
<p>Unit overheating</p>	<ul style="list-style-type: none"> <li>• Check probe calibration</li> <li>• Faulty control board</li> </ul>	<ul style="list-style-type: none"> <li>• If probe is more than 10°F out of calibration, replace probe</li> <li>• Replace control board per Control Board Replacement Section</li> </ul>
<p>Timers fail to run, or won't turn off</p>	<ul style="list-style-type: none"> <li>• Low voltage</li> <li>• Faulty display board</li> <li>• Indented or torn decal</li> </ul>	<ul style="list-style-type: none"> <li>• Check voltage at receptacle to match unit voltage</li> <li>• Check voltage at transformer</li> <li>• Replace display board</li> <li>• Replace control decal</li> </ul>

**1-4. ERROR CODES**

The controls have some self-diagnostic error code capabilities that will show on the display.

Display	Cause	Panel Board Correction
"E-4"	<ul style="list-style-type: none"> <li>Control board too hot; cooling fan clogged or not working</li> </ul>	<ul style="list-style-type: none"> <li>Turn switch to OFF position, then back to ON; if display still shows "E-4", the PC board is getting too hot; clean louvers and check cooling fan; if cooling fan is not working, have it replaced; once panel cools down, the controls should return to normal; if "E-4" persists, replace the PC board</li> </ul>
"E-6"	<ul style="list-style-type: none"> <li>Temperature probe failure</li> </ul>	<ul style="list-style-type: none"> <li>Turn switch to OFF position, then back to ON; if the display shows "E-06", temperature probe should be checked; once the temperature probe is repaired, or replaced, the controls should return to normal; if "E-6" persists, replace PC board</li> </ul>
"E-41"	<ul style="list-style-type: none"> <li>Scrambled memory</li> </ul>	<ul style="list-style-type: none"> <li>Turn switch to OFF position, then back to ON; if the display shows "E-41", the control should be re-initialized (see Special Program Section in Operator's Manual); if "E-41" persists, have PC board replaced</li> </ul>
"HI"	<ul style="list-style-type: none"> <li>Software hi-limit; air temperature too hot</li> </ul>	<ul style="list-style-type: none"> <li>Turn switch to OFF position, then back to ON; if display shows "HI", the heating circuits and temperature probe should be checked; once the unit cools down, the controls should return to normal; if "HI" persists, replace PC board</li> </ul>

## SECTION 2. MAINTENANCE

### 2-1. INTRODUCTION

This section provides procedures for the checkout and replacement of the various parts used within the rotisserie. Before replacing any parts, refer to the Troubleshooting Section. It will aid you in determining the cause of the malfunction.

### 2-2. MAINTENANCE HINTS

1. You may want to use a multimeter to check the electric components.
2. When the manual refers to the circuit being closed, the multimeter should read zero unless otherwise noted.
3. When the manual refers to the circuit being open, the multimeter will read infinity.

### 2-3. LIGHT BULB REPLACEMENT



Figure 2-1



**Light bulbs and glass may be hot. Severe burns could result.**

1. Unscrew the lamp cover (Figure 2-1).
2. Unscrew and remove light bulb, and replace with a new 40 watt bulb - HP part number, BL01-014.
3. Replace lamp cover.

## 2-4. BLOWER REPLACEMENT

1. Remove electrical power supplied to the unit.



**To avoid electrical shock or property damage, move the power switch to OFF and disconnect main circuit breaker, or unplug cord at wall receptacle.**



**Figure 2-2**

2. Remove the side panel closest to the controls.

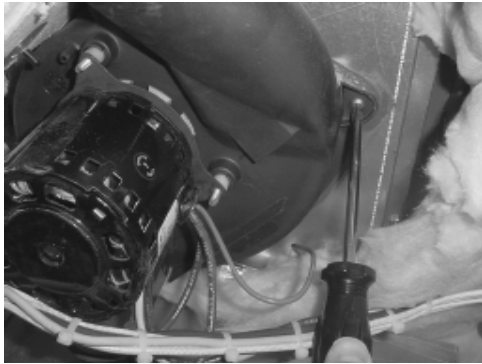

**Figure 2-3**

3. Cut the 3 wires to the blower motor (Figure 2-2).

4. Using a Phillips head screwdriver, remove the mounting screws (Figure 2-3).

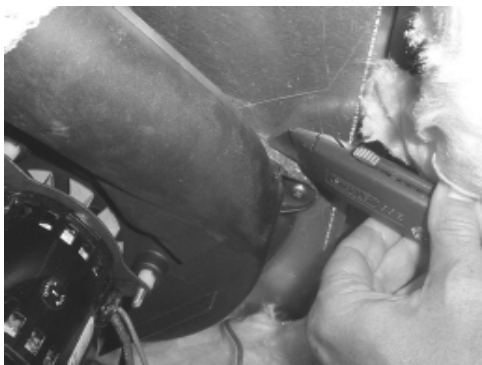

**Figure 2-4**

5. Cut seal around the plastic housing and pull blower from unit (Figure 2-4).

6. Mount new blower, sealing the blower housing with high temperature sealant.

7. Matching the wire colors, connect the wires of new blower with those cut in step 3, using wire nuts or wire splicers.

8. Secure wires to keep out of components.

9. Replace side panel and restore electrical power.



## **2-5. THERMAL SENSOR REPLACEMENT**

1. Remove electrical power supplied to the unit.



**To avoid electrical shock or property damage, move the power switch to OFF and disconnect main circuit breaker, or unplug cord at wall receptacle.**

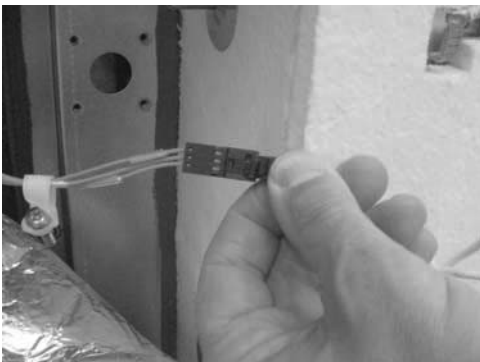

**Figure 2-5**

2. Remove the side panel closest to the controls.

3. Pull back insulation to expose sensor wires.

4. Using a Phillips head screwdriver, remove the mounting plate screws and pull plate from unit (Figure 2-5).



**Figure 2-6**

5. Pull wire connector apart (Figure 2-6).

6. Using a flat-head screwdriver, pry the sensor from the plate (Figure 2-7).



**Figure 2-7**

7. Snap a new sensor onto bracket and replace sensor in reverse order, starting with step 5.

## 2-6. LIGHT FIXTURE REPLACEMENT

1. Remove electrical power supplied to the unit.



**To avoid electrical shock or property damage, move the power switch to OFF and disconnect main circuit breaker, or unplug cord at wall receptacle.**

### **NOTICE**

On stacked units, the top unit must be removed from the top of the SCD to replace the light fixture. Remove the stacking brackets shown in Figure 2-1, then lift the top unit off of the SCD.

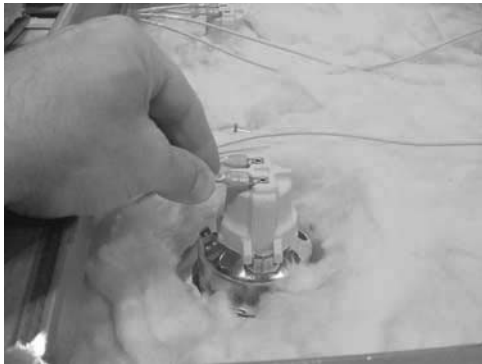

**Figure 2-8**

2. Remove the top cover of the SCD.

3. Remove the wires from the faulty light fixture (Figure 2-8).

4. Push in on the mounting tabs of the light socket, and remove the light socket from the interior of the unit (Figure 2-9).

5. Snap new light fixture into place from the interior of the unit.

6. Replace top cap (and re-stack units where applicable), and restore electrical power.



**Figure 2-9**

## 2-7. POWER SWITCH

1. Remove electrical power supplied to the unit.



**To avoid electrical shock or property damage, move the power switch to OFF and disconnect main circuit breaker, or unplug cord at wall receptacle.**

2. Remove the side panel closest to the controls.

**2-7. POWER SWITCH (Continued)**

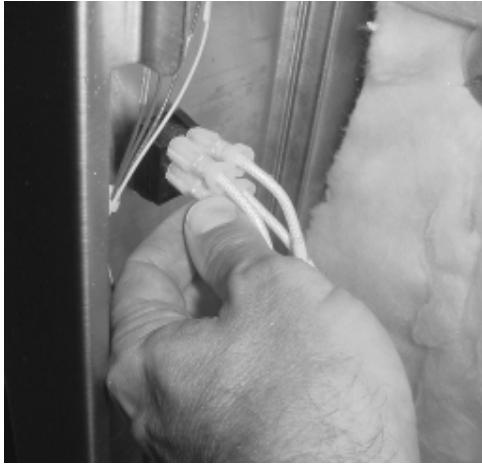

**Figure 2-10**



**Figure 2-11**

**2-8. HEATERS**

3. Label and remove wires from the switch (Figure 2-10).

4. Check for correct continuity of switch.

5. If switch proves bad, push in on the mounting tabs and pull switch from the front of the unit (Figure 2-11).

6. Install new switch in reverse order, and restore electrical power.

1. Remove electrical power supplied to the unit.



**To avoid electrical shock or property damage, move the power switch to OFF and disconnect main circuit breaker, or unplug cord at wall receptacle.**

2. Remove the side panel closest to the controls.

**2-8. HEATERS (Continued)**

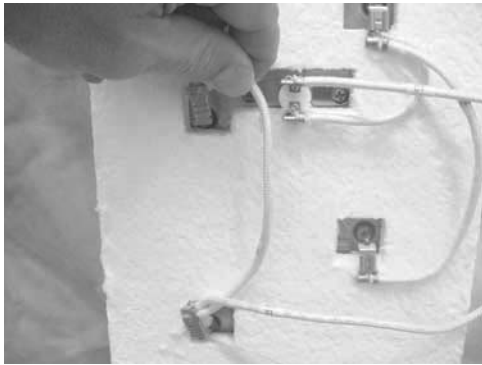

**Figure 2-12**



**Figure 2-13**



**Figure 2-14**

3. Label and remove all wire to heaters and high limit (Figure 2-12).
4. Pull insulation retainers from the nails and remove insulation.
5. Using a Phillips head screwdriver, remove the high limit from top heater, or the plate from the bottom heater (Figure 2-13).
6. Using a Phillips head screwdriver, remove the 6 screws securing the heater and remove from the unit (Figure 2-14).
7. Install new 1000 watt heater in reverse order, and restore electrical power to unit.

## 2-9. RELAYS

### Checkout:

1. Remove electrical power supplied to unit.



**To avoid electrical shock or property damage, move the power switch to OFF and disconnect main circuit breaker, or unplug cord at wall receptacle.**

2. Remove the side panel closest to the controls.



**To avoid electrical shock, make connections before applying power, take reading, and remove power before removing meter leads. The following checks are performed with the wall circuit breaker closed and the main power switch in the ON position.**

3. With power reapplied, let unit start heating up, or enter the Tech Mode in Special Program Mode and check the relays in the output test. (See Special Programming Section of the Operator's Manual.)
4. With the heaters energized, 0 volts should show on the output side of the relay, and 12 volts on the input side.
5. With the component not energized, 208 or 240 volts should show on the output side of relay, and 0 volts on input.
6. If voltage varies from steps 4 and 5, remove power to unit, pull input wires from relay and place leads of meter onto input wires. Reapply power to unit. When unit is running, the input wires to relay should show 12 vdc. If this proves true, the relay is faulty.

## 2-9. RELAYS (Continued)

### **Replacement:**

7. Remove power supplied to unit.



**Figure 2-15**

8. Using a Phillips head screwdriver, remove the wires from relay (Figure 2-15).

9. Using a Phillips head screwdriver, remove the screws securing the relay and remove relay from unit (Figure 2-16).



**Figure 2-16**

10. Coat the back of the new relay with the thermal joint compound.

### **CAUTION**

*Failure to use the thermal joint compound will shorten the life of the relay.*

11. Install new relay and replace wires.

12. Replace side panel and restore electrical power.

## 2-10. CONTROL BOARD REPLACEMENT

1. Remove electrical power supplied to the unit.



To avoid electrical shock or property damage, move the power switch to OFF and disconnect main circuit breaker, or unplug cord at wall receptacle.



Figure 2-17

2. Remove the side panel closest to the controls.

3. Pull connectors from board (Figure 2-17).



Figure 2-18

4. Using 5/16" socket, remove the nuts securing the control board and remove control board (Figure 2-18).

5. Install new board in reverse order, and restore electrical power to unit.

## **NOTICE**

Do not overtighten the nuts to the control board, or the control decal will interfere with the buttons on the control board.

## **2-11. TRANSFORMER REPLACEMENT**

1. Remove electrical power supplied to the unit.



**To avoid electrical shock or property damage, move the power switch to OFF and disconnect main circuit breaker, or unplug cord at wall receptacle.**

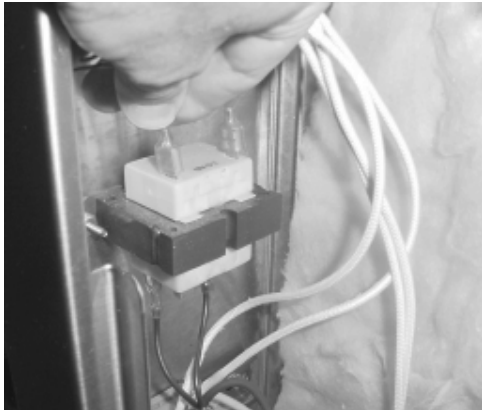

**Figure 2-19**

2. Remove the side panel closest to the controls.
3. Label and remove wires to the transformer (Figure 2-19).



**Figure 2-20**

4. Using 5/16" socket, remove the nuts securing the transformer and remove transformer from unit (Figure 2-20).
5. Install new transformer in reverse order and restore electrical power to the unit.



## **2-12. HIGH LIMIT REPLACEMENT**

1. Remove electrical power supplied to the unit.



**To avoid electrical shock or property damage, move the power switch to OFF and disconnect main circuit breaker, or unplug cord at wall receptacle.**

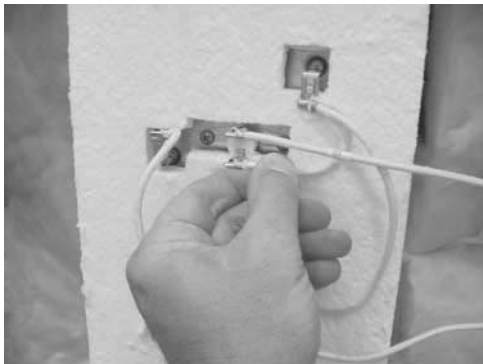

**Figure 2-21**

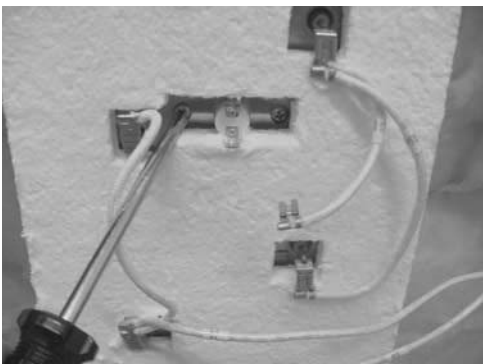

**Figure 2-22**

2. Remove the side panel closest to the controls.
3. Pull wires from the 235°F high limit and check for continuity between terminals (Figure 2-21). If the high limit shows continuity, or closed circuit when cabinet temperature is below 200°F (93°C), the high limit is operating properly and does not need replaced. If it doesn't show continuity, or shows an open circuit, the high limit is faulty and continue on with this section.
4. Using a Phillips head screwdriver, remove the 2 screws securing the high limit and remove high limit from unit (Figure 2-22).
5. Install new high limit, replace side panel, and restore electrical power to unit.

**2-13. WIRING DIAGRAM**

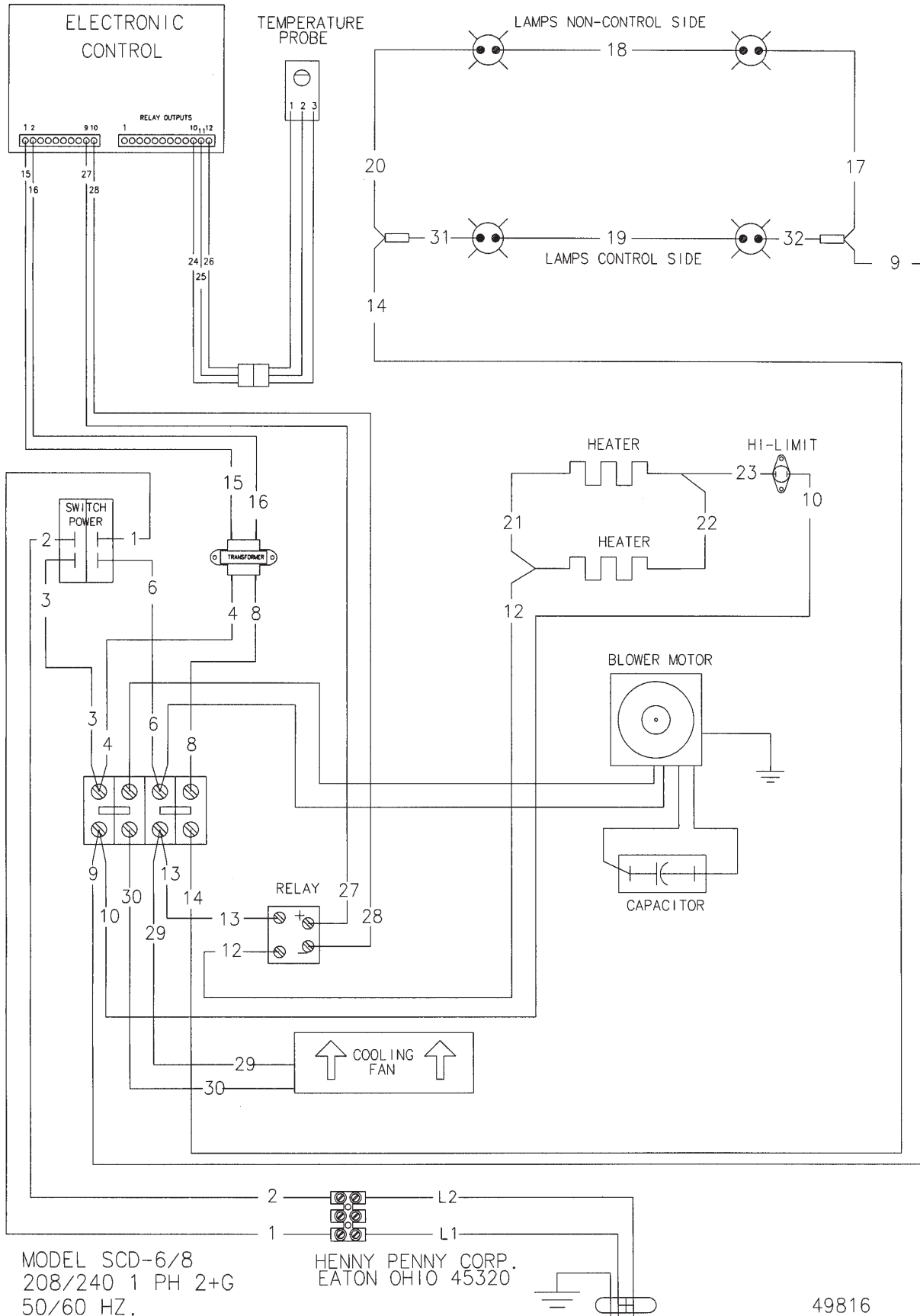



## **LIMITED WARRANTY FOR HENNY PENNY EQUIPMENT**

Subject to the following conditions, Henny Penny Corporation makes the following limited warranties to the original purchaser only for Henny Penny appliances and replacement parts:

**NEW EQUIPMENT:** Any part of a new appliance, except baskets, lamps, and fuses, which proves to be defective in material or workmanship within two (2) years from date of original installation, will be repaired or replaced without charge F.O.B. factory, Eaton, Ohio, or F.O.B. authorized distributor. Baskets will be repaired or replaced for ninety (90) days from date of original installation. Lamps and fuses are not covered under this Limited Warranty. To validate this warranty, the registration card for the appliance must be mailed to Henny Penny within ten (10) days after installation.

**FILTER SYSTEM:** Failure of any parts within a fryer filter system caused by the use of the non-OEM filters or other unapproved filters is not covered under this Limited Warranty.

**REPLACEMENT PARTS:** Any appliance replacement part, except lamps and fuses, which proves to be defective in material or workmanship within ninety (90) days from date of original installation will be repaired or replaced without charge F.O.B. factory, Eaton, Ohio, or F.O.B. authorized distributor.

The warranty for new equipment covers the repair or replacement of the defective part and includes labor charges and maximum mileage charges of 200 miles round trip for a period of one (1) year from the date of original installation.

The warranty for replacement parts covers only the repair or replacement of the defective part and does not include any labor charges for the removal and installation of any parts, travel, or other expenses incidental to the repair or replacement of a part.

**EXTENDED FRYPOT WARRANTY:** Henny Penny will replace any frypot that fails due to manufacturing or workmanship issues for a period of up to seven (7) years from date of manufacture. This warranty shall not cover any frypot that fails due to any misuse or abuse, such as heating of the frypot without shortening.

**0 TO 3 YEARS:** During this time, any frypot that fails due to manufacturing or workmanship issues will be replaced at no charge for parts, labor, or freight. Henny Penny will either install a new frypot at no cost or provide a new or reconditioned replacement fryer at no cost.

**3 TO 7 YEARS:** During this time, any frypot that fails due to manufacturing or workmanship issues will be replaced at no charge for the frypot only. Any freight charges and labor costs to install the new frypot as well as the cost of any other parts replaced, such as insulation, thermal sensors, high limits, fittings, and hardware, will be the responsibility of the owner.

Any claim must be presented to either Henny Penny or the distributor from whom the appliance was purchased. No allowance will be granted for repairs made by anyone else without Henny Penny's written consent. If damage occurs during shipping, notify the sender at once so that a claim may be filed.

THE ABOVE LIMITED WARRANTY SETS FORTH THE SOLE REMEDY AGAINST HENNY PENNY FOR ANY BREACH OF WARRANTY OR OTHER TERM. BUYER AGREES THAT NO OTHER REMEDY (INCLUDING CLAIMS FOR ANY INCIDENTAL OR CONSEQUENTIAL DAMAGES) SHALL BE AVAILABLE.

The above limited warranty does not apply (a) to damage resulting from accident, alteration, misuse, or abuse; (b) if the equipment's serial number is removed or defaced; or (c) for lamps and fuses. THE ABOVE LIMITED WARRANTY IS EXPRESSLY IN LIEU OF ALL OTHER WARRANTIES, EXPRESS OR IMPLIED, INCLUDING MERCHANTABILITY AND FITNESS, AND ALL OTHER WARRANTIES ARE EXCLUDED. HENNY PENNY NEITHER ASSUMES NOR AUTHORIZES ANY PERSON TO ASSUME FOR IT ANY OTHER OBLIGATION OR LIABILITY.

Revised 01/01/07

## SECTION 3. PARTS INFORMATION

### **3-1. INTRODUCTION**

This section identifies and lists the replaceable parts of the Henny Penny SCD Rotisserie Merchandiser.

### **3-2. GENUINE PARTS**

Use only genuine Henny Penny parts in your cabinet. Using a part of lesser quality or substitute design may result in cabinet damage or personal injury.

### **3-3. HOW TO ORDER**

Once the part you want to order has been found in the Parts List, write down the following information:

1. From the Parts List  
(Sample)

Item Number 3  
Part Number 40645  
Description Relay

2. From the data plate  
(Sample)

Product Number SCD6.0  
Serial Number AE001IH  
Voltage 208V

### **3-4. PRICES**

Your distributor has a price parts list and will be glad to inform you of the cost of your parts order.

### **3-5. DELIVERY**

Commonly replaced items are stocked by your distributor and will be sent out when your order is received. Other parts will be ordered by your distributor from Henny Penny Corporation. Normally, these will be sent to your distributor within three working days.

### **3-6. WARRANTY**

All replacement parts (except lamps and fuses) are covered under warranty for 90 days against manufacturing defects and workmanship. If damage occurs during shipping, notify the carrier at once so that a claim may be properly filed. Refer to warranty on the front of this section for other rights and limitations.

### **3-7. RECOMMENDED SPARE PARTS FOR DISTRIBUTORS**

Recommended replacement parts, stocked by your distributor, are indicated with ✓ in the parts lists. Please use care when ordering recommended parts, because all voltages and variations are marked. Distributors should order parts based upon common voltages and equipment sold in their territory.

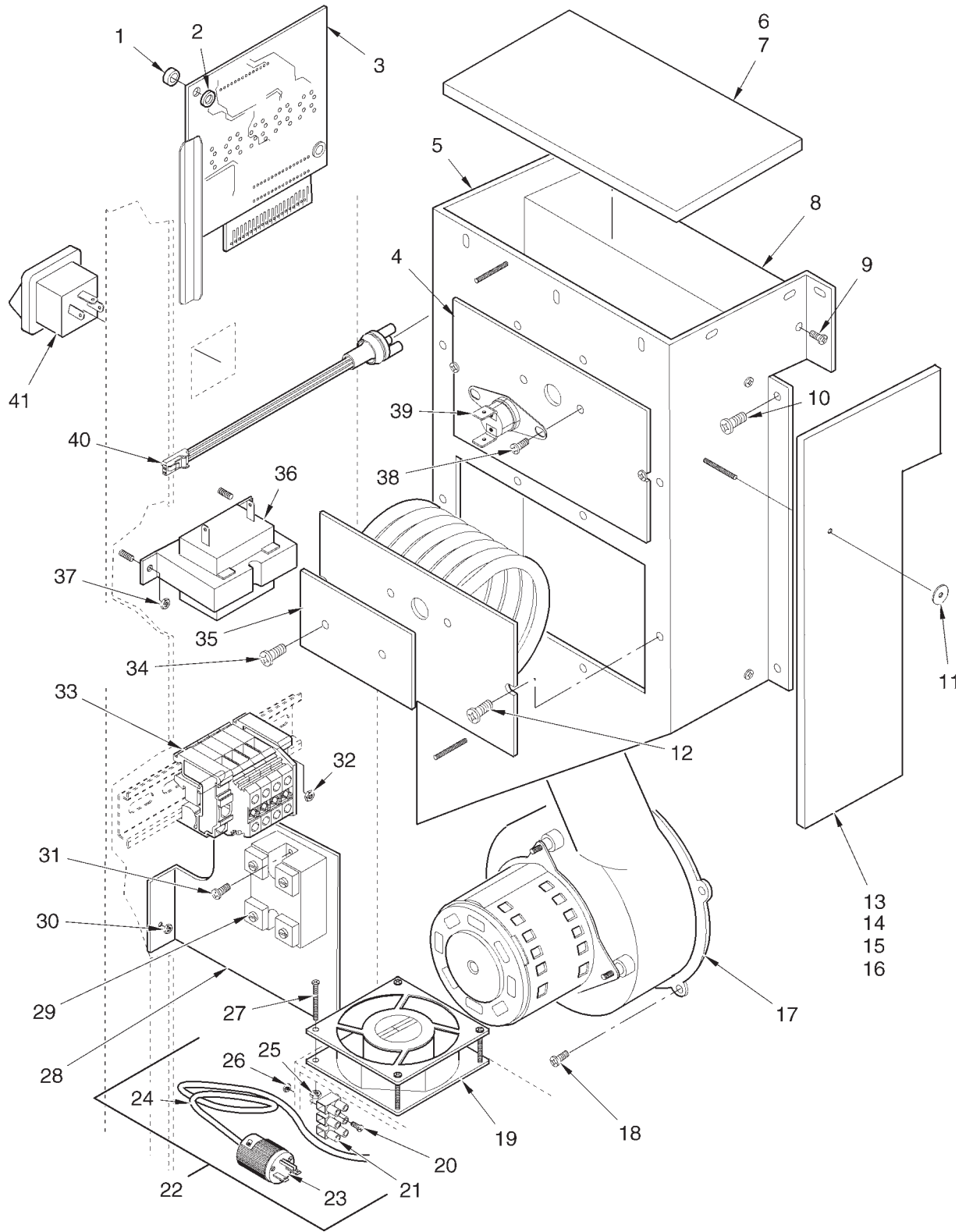

**Figure 3-1. Electrical Controls**

FIG. & ITEM NO.	PART NO.	DESCRIPTION	SCD-8	SCD-6
3-1		ELECTRICAL CONTROLS		
1	ME50-014	SPACER	4	4
2	NS02-005	NUT	4	4
√ 3	51101RB	CONTROL BOARD ASSEMBLY	1	1
√ 4	49214	HEATER - 208V-1000W (UNDER INSUL.)	2	2
√ 4	49215	HEATER - 240V-1000W (UNDER INSUL.)	2	2
5	50614	HEATER BOX	1	1
6	49900	INSULATION - HEATER BOX CAP	1	1
7	49899	INSULATION - HEATER BOX TOP	2	2
8	49211	BAFFLE - BLOWER	1	1
9	SC02-016	SCREW	9	9
10	SC02-016	SCREW	7	7
11	WA02-001	WASHER	7	7
12	SC02-016	SCREW	6	6
13	49903	INSULATION - HEATER BOX, RH	1	1
14	49902	INSULATION - HEATER BOX, LH	1	1
15	49901	INSULATION - HEATER BOX, BOTTOM	1	1
16	49898	INSULATION - HEATER BOX, FRONT	1	1
√ 17	39308	BLOWER - HIGH TEMP.	1	1
18	SC01-124	SCREW (#8-32 X 3/4 PH THD SS)	4	4
19	37398	COOLING FAN	1	1
20	SC01-058	SCREW	2	2
21	ME50-021	TERMINAL BLOCK	1	1
22	49957	POWER CORD ASSEMBLY	1	1
23	36810	. PLUG-15 AMP-250V	1	1
24	49956	. POWER CORD		
25	NS02-005	NUT	4	4
26	NS02-005	NUT	2	2
27	SC01-037	SCREW	4	4
28	49949	BRACKET, RELAY	1	1
√ 29	40645	RELAY	1	1
30	NS02-005	NUT	2	2
31	SC02-041	SCREW	2	2
32	NS02-005	NUT	1	1
33	52994	TERMINAL BLOCK ASSEMBLY	1	1
34	SC02-016	SCREW	2	2
35	43719	HOLE COVER	1	1
√ 36	28979	TRANSFORMER-PRI. 208/240V-SEC. 12V	1	1
37	NS02-005	NUT	2	2
38	SC02-016	SCREW	2	2
√ 39	18201	HIGH LIMIT	1	1
√ 40	52100	TEMPERATURE SENSOR ASSY (UNDER INSUL.)	1	1
√ 41	43768	POWER SWITCH - 125-250V	1	1

√ recommended parts

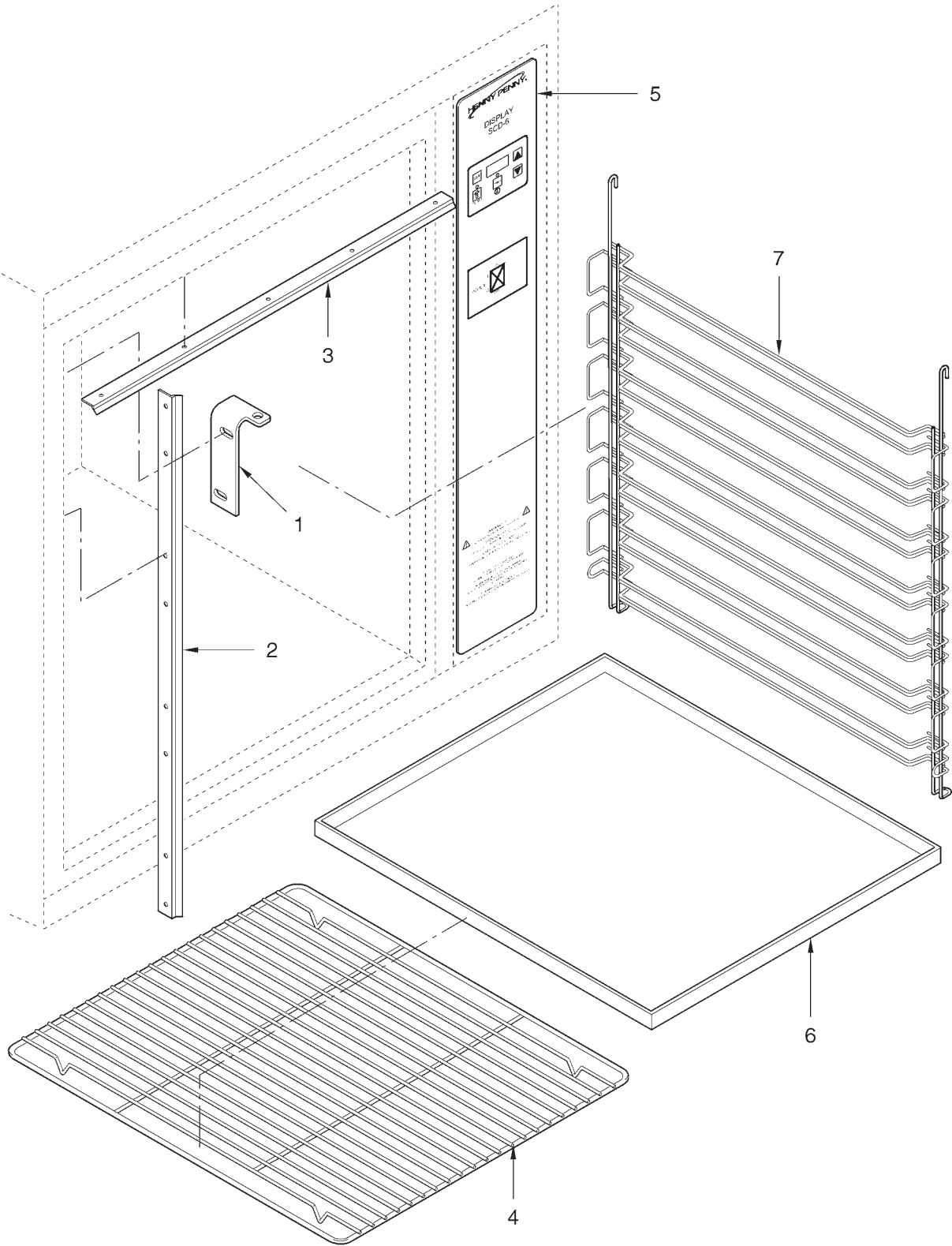
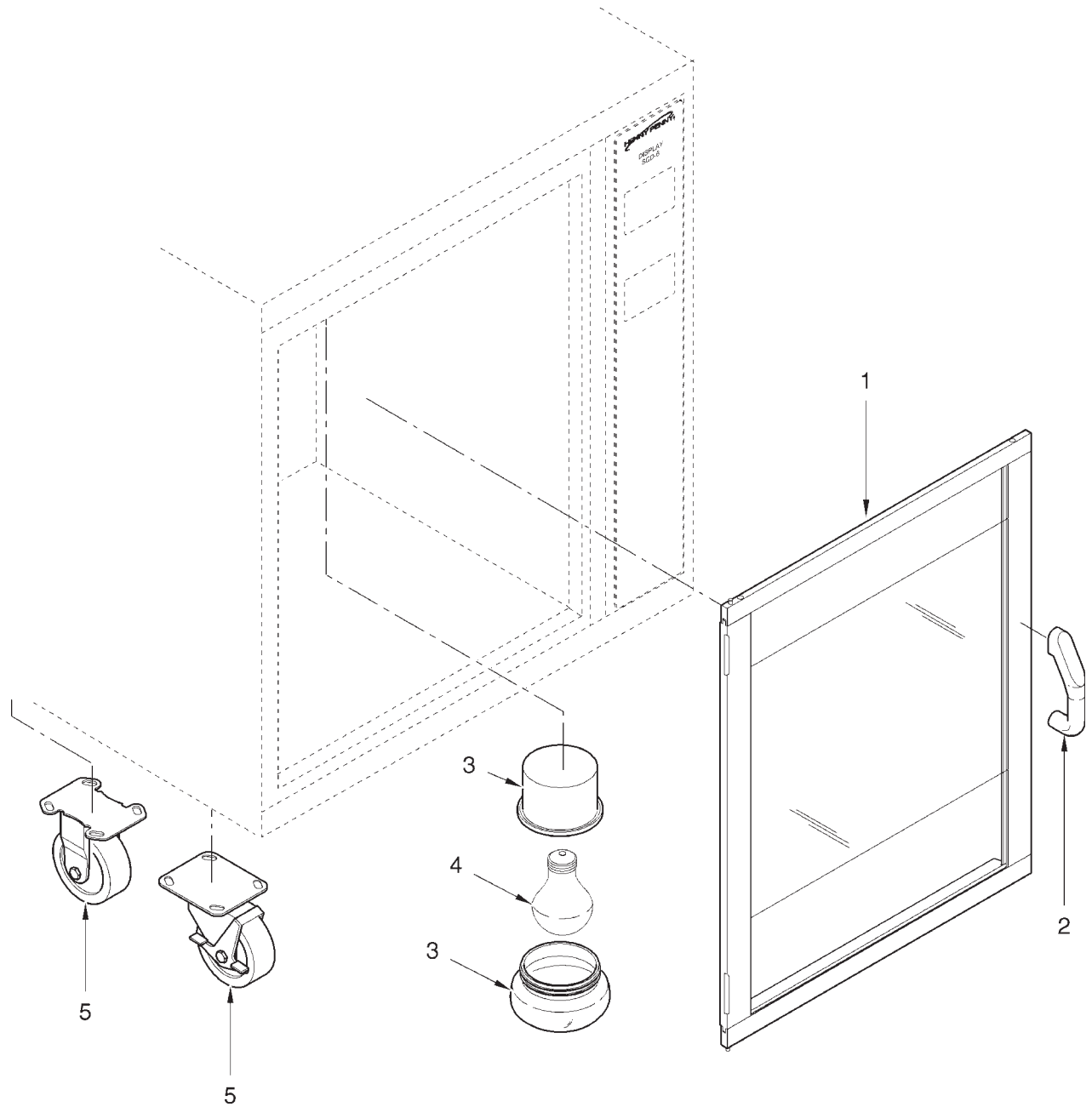

**Figure 3-2. Drip Pan and Racks**



FIG. & ITEM NO.	PART NO.	DESCRIPTION	SCD-8	SCD-6
3-2		DRIP PAN AND RACKS		
1	48549	HINGE - CONTROL SIDE	1	1
1	48567	HINGE - CUSTOMER SIDE	1	1
√ 2	49863	DOOR GASKET - SIDE - SCD-8	2	-
√ 2	49861	DOOR GASKET - SIDE - SCD-6	-	2
√ 3	49862	DOOR GASKET - TOP - SCD-8	2	-
√ 3	49860	DOOR GASKET - TOP - SCD-6	-	2
4	40882	SHELF - SCD-8	6	-
4	40871	SHELF - SCD-6	-	6
5	49842	DECAL - CONTROL PANEL - SCD-8	1	-
5	49841	DECAL - CONTROL PANEL - SCD-6	-	1
5	61473	DECAL - CONTROL PANEL - SCD-8 - POLLO	1	-
6	40925	DRIP PAN - SCD-8	1	-
6	40923	DRIP PAN - SCD-6	-	1
7	49175	SIDE RACK - SCD-8	2	-
7	49174	SIDE RACK - SCD-6	-	2

√ recommended parts



**Figure 3-3. Door, Light, and Casters**

FIG. & ITEM NO.	PART NO.	DESCRIPTION	SCD-8	SCD-6
3-3		DOOR, LIGHT, AND CASTERS		
1	49751	DOOR ASSY. - CONTROL - W/HANDLE	1	-
1	49752	DOOR ASSY. - CONTROL - MIR. - W/HANDLE	1	-
1	49753	DOOR ASSY. - CUST. - W/O HANDLE	1	-
1	49754	DOOR ASSY. - CUST. - W/HANDLE	1	-
1	49755	DOOR ASSY. - CUST. - MIR. - W/O HANDLE	1	-
1	49756	DOOR ASSY. - CUST. - MIR. - W/HANDLE	1	-
1	49261	DOOR ASSY. - CONTROL - W/HANDLE	-	1
1	49262	DOOR ASSY. - CONTROL - MIR. - W/HANDLE	-	1
1	49263	DOOR ASSY. - CUST. - W/O HANDLE	-	1
1	49264	DOOR ASSY. - CUST. - W/HANDLE	-	1
1	49265	DOOR ASSY. - CUST. - MIR. - W/O HANDLE	-	1
1	49266	DOOR ASSY. - CUST. - MIR. - W/HANDLE	-	1
2	44757	DOOR HANDLE	1 OR 2	1 OR 2
3	51854	LIGHT FIXTURE	4	4
√ 4	BL01-014	LIGHT BULB - 40 WATT	4	4
5	40948	CASTER 4 IN. - RIGID (REAR)	2	2
5	40947	CASTER 4 IN. - SWIVEL (FRONT)	2	2
6	41356*	LEG ASSEMBLY (OPTIONAL)	4	4

√ recommended parts

\* not shown