



Henny Penny
Open Fryer Electric

Model OE-30X

Model OG-30X

SERVICE MANUAL

Henny Penny Open Fry Station



Model: OE-301 - electric
OG-301 - gas

Product Number: 01408 - natural gas
02458 - 208 electric



Model: OE-302 - electric
OG-302 - gas

Product Number: 01406 - natural gas
02456 - 208 electric

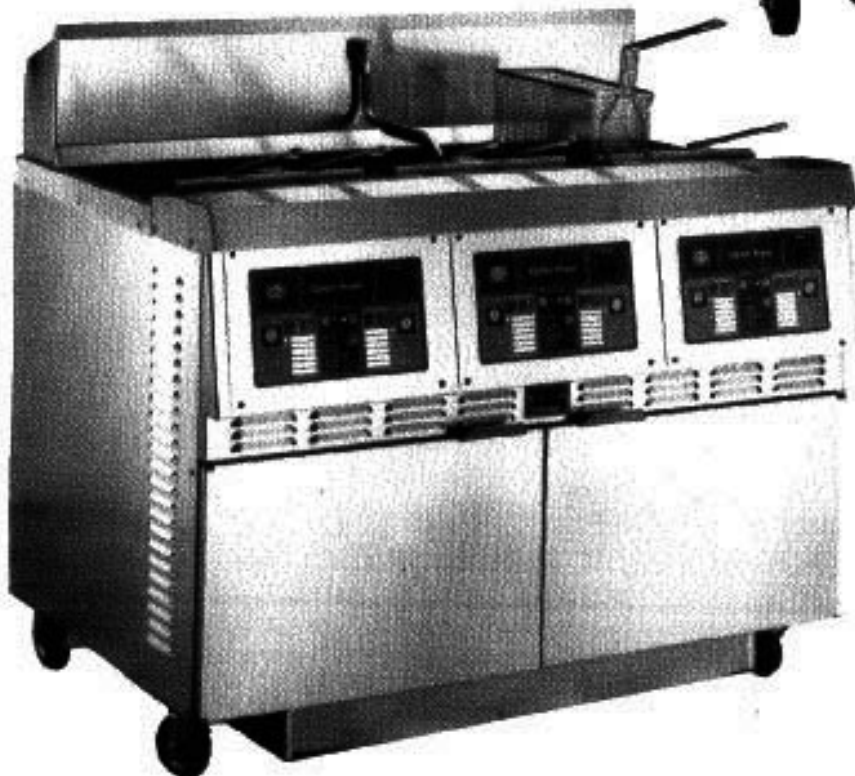

Model: OE-303 - electric
OG-303 - gas

Product Number: 01400 - natural gas
02450 - 208 electric

LIMITED WARRANTY FOR HENNY PENNY APPLIANCES

Subject to the following conditions, Henny Penny Corporation makes the following limited warranties to the original purchaser only for Henny Penny appliances and replacement parts:

NEW EQUIPMENT: Any part of a new appliance, except lamps and fuses, which proves to be defective in material or workmanship within two (2) years from date of original installation, will be repaired or replaced without charge F.O.B. factory, Eaton, Ohio, or F.O.B. authorized distributor. To validate this warranty, the registration card for the appliance must be mailed to Henny Penny within ten (10) days after installation.

REPLACEMENT PARTS: Any appliance replacement part, except lamps and fuses, which proves to be defective in material or workmanship within ninety (90) days from date of original installation will be repaired or replaced without charge F.O.B. factory, Eaton, Ohio, or F.O.B. authorized distributor.

The warranty for new equipment and replacement parts covers only the repair or replacement of the defective part and does not include any labor charges for the removal and installation of any parts, travel or other expenses incidental to the repair or replacement of a part.

EXTENDED FRYPOT WARRANTY: Henny Penny will replace any frypot that fails due to manufacturing or workmanship issues for a period of up to seven (7) years from date of manufacture. This warranty shall not cover any frypot that fails due to any misuse or abuse, such as heating of the frypot without shortening.

0 TO 3 YEARS: During this time, any frypot that fails due to manufacturing or workmanship issues will be replaced at no charge for parts, labor, or freight. Henny Penny will either install a new frypot at no cost or provide a new or reconditioned replacement fryer at no cost.

3 TO 7 YEARS: During this time, any frypot that fails due to manufacturing or workmanship issues will be replaced at no charge for the frypot only. Any freight charges and labor costs to install the new frypot as well as the cost of any other parts replaced, such as insulation, thermal sensors, high limits, fittings, and hardware, will be the responsibility of the owner.

Any claim must be represented to either Henny Penny or the distributor from whom the appliance was purchased. No allowance will be granted for repairs made by anyone else without Henny Penny's written consent. If damage occurs during shipping, notify the sender at once so that a claim may be filed.

THE ABOVE LIMITED WARRANTY SETS FORTH THE SOLE REMEDY AGAINST HENNY PENNY FOR ANY BREACH OF WARRANTY OR OTHER TERM. BUYER AGREES THAT NO OTHER REMEDY (INCLUDING CLAIMS FOR ANY INCIDENTAL OR CONSEQUENTIAL DAMAGES) SHALL BE AVAILABLE.

The above limited warranty does not apply (a) to damage resulting from accident, alteration, misuse, or abuse; (b) if the equipment's serial number is removed or defaced; or (c) for lamps and fuses. THE ABOVE LIMITED WARRANTY IS EXPRESSLY IN LIEU OF ALL OTHER WARRANTIES, EXPRESS OR IMPLIED, INCLUDING MERCHANTABILITY AND FITNESS, AND ALL OTHER WARRANTIES ARE EXCLUDED. HENNY PENNY NEITHER ASSUMES NOR AUTHORIZES ANY PERSON TO ASSUME FOR IT ANY OTHER OBLIGATION OR LIABILITY

WARNING

This manual should be retained in a convenient location for future reference.

Wiring diagram for this appliance is located on the inside access door below the control panel.

Post in a prominent location, instructions to be followed in event user smells gas. This information shall be obtained by consulting the local gas supplier.



FOR YOUR SAFETY

DO NOT STORE OR USE GASOLINE OR OTHER FLAMMABLE VAPORS AND LIQUIDS IN THE VICINITY OF THIS OR ANY OTHER APPLIANCE.

Keep appliance area free and clear from combustables.

Do not obstruct the flow of combustion and ventilation air. Adequate clearance must be left all around appliance for sufficient air to the combustion chamber.

NOTE

The Model OG-301/302/303 Fryers are equipped with a continuous pilot. Fryer can not be operated without electric power. Fryer will automatically return to normal operation when power is restored.

WARNING

WARNING: Improper installation, adjustment, alteration, service or maintenance can cause property damage, injury or death. Read the installation, operating and maintenance instructions thoroughly before installing or servicing this equipment.

Technical Data for CE Marked Products

Nominal Heat Input: (Net)	Natural (I_{2H}) = 21,1 KW (72,000 Btu/h) Liquid Propane (I_{3P}) = 21,1 KW (72,000 Btu/h)
Nominal Heat Input: (Gross)	Natural (I_{2H}) = 23,4 KW (80,000 Btu/h) Liquid Propane (I_{3P}) = 23,4 KW (80,000 Btu/h)
Supply Pressure:	Natural (I_{2H}) = 20 mbar Liquid Propane (I_{3P}) = 37 mbar Liquid Propane (I_{3P}) = 50 mbar
Test Point Pressure:	Natural (I_{2H}) = 8,7 mbar Liquid Propane (I_{3P}) = 25 mbar
Injector Size:	Natural (I_{2H}) = 0,66 mm Liquid Propane (I_{3P}) = 1,04 mm

This appliance must be installed in accordance with the manufacturers instructions and the regulations in force and only used in a suitable ventilated location. Read the instructions fully before installing or using the appliance.

Datos Tecnicos Para Products CE

Consumo Calorico Nominal: (Neto)	Gas Natural (I_{2H}) = 21,1 KW (72,000 Btu/h) Propano Licuado (I_{3P}) = 21,1 KW (72,000 Btu/h)
Consumo Calorico Nominal: (Bruto)	Gas Natural (I_{2H}) = 21,1 KW (80,000 Btu/h) Propano Licuado (I_{3P}) = 21,1 KW (80,000 Btu/h)
Presion De Alimentacion:	Gas Natural (I_{2H}) = 20 mbar Propano Licuado (I_{3P}) = 37 mbar Propano Licuado (I_{3P}) = 50 mbar
Presion En Ez Punto De Prueba:	Gas Natural (I_{2H}) = 8,7 mbar Propano Licuado (I_{3P}) = 25 mbar
Diámetro Boquilla:	Gas Natural (I_{2H}) = 0,66 mm Propano Licuado (I_{3P}) = 1,04 mm

Este equipo debe instalarse únicamente en un recinto adecuadamente ventilado y conforme a las indicaciones del fabricante y a las normas vigentes. Lea completamente las instrucciones antes de instalar o usar este equipo.

TABLE OF CONTENTS

Section	Page
Section 1. INTRODUCTION	1-1
1-2. Model Variations	1-1
1-3. Features	1-1
1-4. Safety	1-1
1-5. Assistance	1-2
Section 2. INSTALLATION	2-1
2-1. Introduction	2-1
2-2. Unpacking	2-1
2-3. Selecting the Location	2-2
2-4. Leveling the Fry Station	2-2
2-5. Ventilation of Fry Station	2-2
2-6. Gas Supply	2-3
2-7. Gas Leak Test	2-5
2-8. Gas Pilot Lighting	2-6
2-9. Gas Pilot Shut Down Procedure	2-7
2-10. Pressure Regulator	2-7
2-11. Electrical Requirements OG-301/302/303	2-7
2-12. Electrical Requirements OE-301/302/303	2-8
2-13. Testing the Fry Station	2-8
Section 3. OPERATION	3-1
3-1. Introduction	3-1
3-2. Operating Controls	3-1
3-3. Filling or Adding Shortening	3-11
3-4. Operating Controls and Procedures	3-11
3-5. Filtering of Shortening	3-13
3-6. Filter Pump Problems	3-14
3-7. Filter Pump Motor Protector	3-15
3-8. Changing the Filter Envelope	3-15
3-9. Cleaning the Cookpots	3-17
Section 4. PROGRAMMING	4-1
4-1. First Level Program Mode	4-1
4-2. Second Level Program Mode	4-2
4-3. Idle Programming	4-3
4-4. Third Level Program Mode	4-3
4-5. Special Program Mode	4-4
Section 5. TROUBLESHOOTING	5-1
5-1. Introduction	5-1
5-2. Troubleshooting	5-1

TABLE OF CONTENTS (Continued)

Section	Page
Section 6. MAINTENANCE	6-1
6-1. Introduction	6-1
6-2. Test Instruments	6-1
6-3. Removing the Control Panel	6-1
6-4. Thermal Sensor (Probe)	6-2
6-5. High Temperature Limit Control (electric models)	6-4
6-6. High Temperature Limit Control (gas models)	6-6
6-7. Heating Elements (electric models only)	6-8
6-8. Heating Contactors (electric models)	6-10
6-9. Gas Burner Assembly (gas models)	6-12
6-10. Thermocouple (gas models)	6-14
6-11. Gas Control Valve	6-15
6-12. Fuses and Fuse Holders	6-18
6-13. Drain Switch	6-19
6-14. Power On/Off Switch	6-20
6-15. Filter Switch	6-21
6-16. Filtering System	6-22
6-17. Gas Conversion	6-25
6-18. Gas Safety Solenoid (gas models only)	6-27
Section 7. PARTS INFORMATION	7-1
7-1. Introduction	7-1
7-2. Genuine Parts	7-1
7-3. When Ordering Parts	7-1
7-4. Prices	7-1
7-5. Delivery	7-1
7-6. Warranty	7-1

Henny Penny Distributor Lists (Domestic and International)

SECTION 1. INTRODUCTION

1-1. INTRODUCTION.

The Henny Penny Open Fry Station is a basic unit of food equipment designed to cook foods better and easier. The microcomputer based design helps make this possible.

1-2. MODEL VARIATIONS

This manual covers the following variations of the Henny Penny Open Fry Station:

- Model OG-301/302/303 (gas model)
- Model OE-301/302/303 (electric model)

1-3. FEATURES

- Easily cleaned.
- 43 lb. shortening capacity - gas model.
- 48 lb. shortening capacity - electric model.
- 2 Half size baskets per well (or full size baskets).
- Microcomputer control.
- Stainless steel construction.
- Manual reset high limit control.
- Self-diagnostic system built into controls.
- Built in filter (handles all 3 wells).

1-4. SAFETY

The Henny Penny Fry Station has many safety features incorporated. However, the only way to ensure safe operation is to fully understand the proper installation, operation, and maintenance procedures. The instructions in this manual have been prepared to aid you in learning the proper procedures. Where information is of particular importance or is safety related, the words **DANGER**, **WARNING**, **CAUTION**, or **NOTE** are used. Their usage is described below:



The word **DANGER** indicates an imminent hazard which will result in highly serious injury such as second or third degree burns.

1-4. SAFETY
(Continued)

WARNING

The word **WARNING** is used to alert you to a procedure that if not performed properly, might cause personal injury.

CAUTION

The word **CAUTION** is used to alert you to a procedure that, if not performed properly, may damage the fry station.

NOTE

The word **NOTE** is used to highlight especially important information.

1-5. ASSISTANCE

Should you require outside assistance, just call your local independent distributor maintained by Henny Penny Corporation.

In addition, feel free to contact our corporate headquarters in Eaton, Ohio. Dial 1-800-417-8417 toll free.

SECTION 2. INSTALLATION

2-1. INTRODUCTION

This section provides the installation instructions for the Henny Penny Fry Station.

NOTE

Installation of the unit should be performed only by a qualified service technician.

WARNING

Do not puncture the unit with any objects such as drills or screws as component damage or electrical shock could result.

2-2. UNPACKING

The Henny Penny Fry Station has been tested, inspected, and expertly packed to ensure arrival at its destination in the best possible condition. The unit is bolted to a wooden skid and then packed inside a heavy cardboard carton with sufficient padding to withstand normal shipping treatment.

NOTE

Any shipping damage should be noted in the presence of the delivery agent and signed prior to his or her departure.

1. Carefully cut bands from cardboard carton.
2. Lift carton from fryer.

WARNING

This manual should be retained in a convenient location for future reference.

Wiring diagram for this appliance is located on the inside access door below the control panel. Post in a prominent location, instructions to be followed in event user smells gas. This information shall be obtained by consulting the local gas supplier.

2-3. SELECTING THE LOCATION

The proper location of the Fry Station is very important for operation, speed, and convenience. The location of the fry station should allow clearances for servicing and proper operation. Choose a location which will provide easy loading and unloading without interfering with the final assembly of food orders. Operators have found that frying from raw to finish, and holding the product in warmers provides fast continuous service. Keep in mind the best efficiency will be obtained by a straight line operation, i.e. raw in one side and finished out the other side. Order assembly can be moved away with only a slight loss of efficiency.

The fryer should be installed in such a way as to prevent tipping or movement causing splashing of hot liquid shortening. This may be accomplished by the location the fry station is in, or by restraining ties.



The gas Model OG-300 Series Fry Station is designed for installation on combustible floors and adjacent to combustible walls. Fry Station must be installed with a minimum clearance from all combustible, and noncombustible materials, 4 inches from side and 4 inches from the back.

2-4. LEVELING THE FRY STATION

For proper operation, the fry station should be level from side to side and front to back. Using a level place on the flat areas around the frypot collar, on the middle well, adjust the casters until the unit is level.

2-5. VENTILATION OF FRY STATION

The fry station should be located with provision for venting into an adequate exhaust hood or ventilation system. This is essential to permit efficient removal of the steam exhaust and frying odors. Special precaution must be taken in designing an exhaust canopy to avoid interference with the operation of the fry station. We recommend you consult a local ventilation or heating company to help in designing an adequate system.

NOTE

Ventilation must conform to local, state, and national codes. Consult your local fire department or building authorities.

2-5. VENTILATION OF FRY STATION (Continued)**WARNING**

When installing the gas fry station do not attach an extension to the gas flue exhaust stack. This may impair proper operation of the burner, causing malfunctions and possible negative back draft.

2-6. GAS SUPPLY

The gas fry station is factory available for either natural or propane gas. Check the data plate inside the front door of the cabinet to determine the proper gas supply requirements.

NOTE

The OG-301 can be operated at altitudes of up to 4000 feet above sea level with no changes to the unit. For operation above 4000 feet, please contact Henny Penny Corporation for changes to the unit.



Do not attempt to use any gas other than that specified on the data plate. Incorrect gas supply could result in a fire or explosion.

Please refer to the illustration on the following page for the recommended hookup of the fry station to the main gas line supply.

WARNING

To avoid possible serious personal injury:

- Installation must conform with American National Standard Z223.1-Latest Edition National Fuel Gas Code and the local municipal building codes. In Canada, installation must be in accordance with Standard CAN/CGA B 1 49.1 & .2, Installation Codes - Gas Burning Appliances and local codes.
- The fry station and its individual shutoff valve must be disconnected from the gas supply piping system during any pressure testing of that system at test pressures in excess of 1/2 PSIG (3.45 KPA).
- The fry station must be isolated from the gas supply piping system by closing its individual manual shut off valve during any pressure testing of the gas supply piping system at test pressures equal to or less than 1/2 PSIG (3.45 KPA).

2-6. GAS SUPPLY (continued)

RIGHT

MINIMUM PULL of equipment away from wall permissible for accessibility to Quick Disconnect Device.

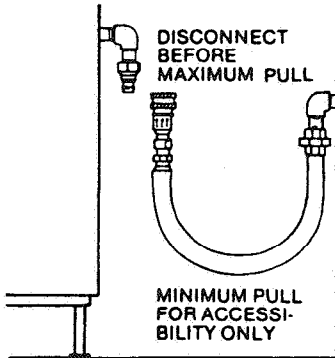

WRONG

AVOID SHARP BENDS AND KINKS when pulling equipment away from wall. (Maximum pull will kink ends, even if installed properly, and reduce Connector life.)

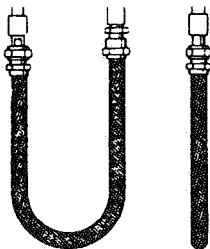
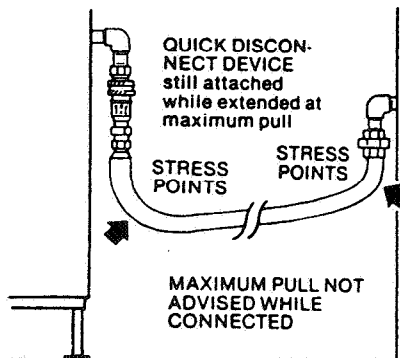

RIGHT

Couplings and hose should be installed in the same plane as shown at left. DO NOT OFFSET COUPLINGS—this causes torsional twisting and undue strain causing premature failure.

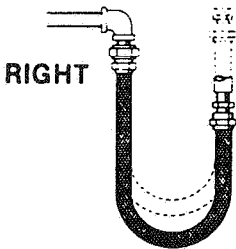
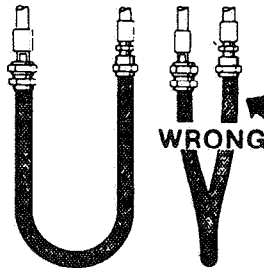

RIGHT

This is the correct way to install metal hose for vertical traverse. Note the single, natural loop.

Allowing a sharp bend, as shown at right, strains and twists the metal hose to a point of early failure at the coupling.

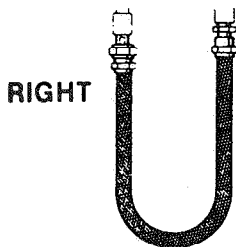
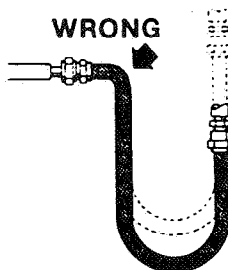

RIGHT

Maintain the minimum or larger bending diameter between the couplings for longest life.

Closing in the diameter at the couplings, as shown at right, creates double bends causing work fatigue failure of the fittings.

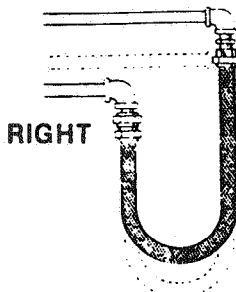

RIGHT

In all installations where "self-draining" is not necessary, connect metal hose in a vertical loop.

DO NOT CONNECT METAL HOSE HORIZONTALLY... unless "self-draining" is necessary, then use support on lower plane as shown at left.

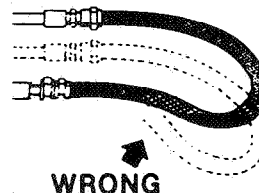

2-6. CABLE RESTRAINT

Please refer to the illustration below when installing cable restraint on all moveable gas fryers.

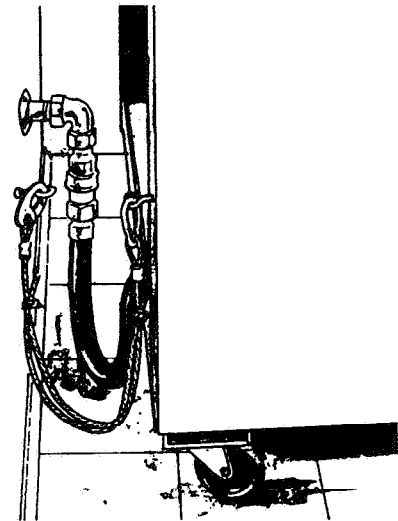

I-bolt is to be secured to the building using acceptable building construction practices.

CAUTION

DRY WALL CONSTRUCTION

Secure I-bolt to a building stud. DO NOT attach to dry wall only. Also, locate the I-bolt at the same height as the gas service. Preferred installation is approximately six inches to either side of service. Cable restraint must be at least six inches shorter than flexible gas line.

CAUTION

Utilize elbows when necessary to avoid sharp kinks or excessive bending. For ease of movement, install with a "lazy" loop. Gas appliance must be disconnected prior to maximum movement. (Minimum movement is permissible for hose disconnection).

**2-6. GAS SUPPLY
(Continued)**

- A standard one inch, black steel pipe and malleable fittings should be used for gas service connections.
- Do not use cast iron fittings.
- Although one inch size pipe is recommended, piping should be of adequate size and installed to provide a supply of gas sufficient to meet the maximum demand without undue loss of pressure between the meter and the fry station. The pressure loss in the piping system should not exceed 0.3 inch water column.

Provisions should be made for moving the fry station for cleaning and servicing. This may be accomplished by:

1. Installing a manual gas shut off valve and a disconnect union, or
2. Installing a heavy duty design A.G.A. certified connector. In order to be able to service this appliance, which is provided with casters, a connector complying with ANSI Z21.69 or CAN/CGA 6.16 and a quick-disconnect device complying with ANSI Z21.41 or CAN 1-6.9 must be installed. It must also be installed with restraining means to guard against transmission of strain to the connector as specified in the appliance manufacturer's instruction.
3. Refer to the cable restraint instructions (illustration 2-6) on how and where to attach the restraining devices to the wall and fryer.

2-7. GAS LEAK TEST

NOTE

Prior to turning the gas supply on, be sure the gas dial cock on fry station gas valve is in the OFF position. After the piping and fittings have been installed, check for gas leaks. A simple checking method is to turn on the gas and brush all connections with a soap solution. If bubbles occur, it indicates escaping gas. In this event, the piping connection must be redone.



Never use a lighted match or open flame to test for gas leaks. Escaping gas could cause an explosion resulting in severe personal injury.

2-8. GAS PILOT LIGHTING

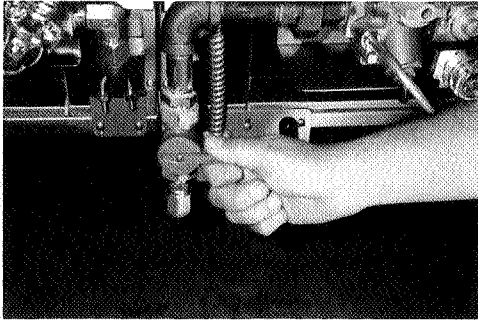

OFF

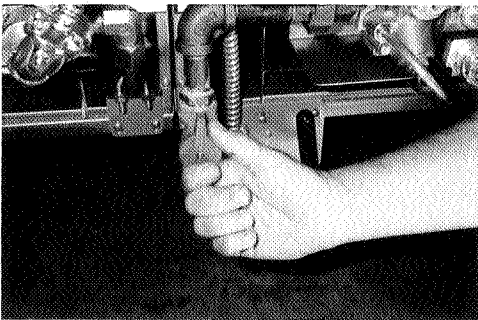

ON

The following steps provide the pilot PROCEDURE lighting procedure:

1. Open doors and open gas shut-off valve. (see illustrations)
2. The gas cock dial has a dual function:
 - a. Complete control of gas to the pilot and main burner.
 - b. When in the pilot position, it is the reset mechanism for the automatic pilot.
3. Partially depress and turn the control gas cock dial to the OFF position.
4. Wait a sufficient length of time to allow any gas which may have accumulated in the burner compartment to escape (at least 5 minutes).
5. Turn the main power switch to the OFF position.
6. Turn the gas cock dial to the PILOT position.
7. Depress and hold gas cock dial while lighting the pilot. Allow the pilot to burn approximately 30 seconds before releasing the gas cock dial. The pilot should remain lighted.

NOTE

If the pilot does not remain lighted, repeat steps 2 and 3, allowing a longer period of time before releasing the gas cock dial.

8. Turn the gas cock dial to the ON position.
9. Turn the power switch to the "ON" position.
10. Listen for the gas burner ignition. It will be an audible sound due to the gas igniting at the gas jets within the burner.

CAUTION

Do not leave the power switch on for more than 10 seconds; damage to the frypot may result.

11. The frypots should be cleaned per the instructions in section 3.
12. The frypots must be filled to the proper level with shortening. Refer to section 3-4.
13. The fry station is now ready for operation.

**2-9. GAS PILOT SHUT DOWN
PROCEDURE**

Depress lightly and turn manual lever on gas valve to the OFF position.

2-10. PRESSURE REGULATOR

The gas pressure regulator on the automatic gas valve is factory set as follows:

- Natural: 3.5 inches water column.
- Propane 10 0 inches water column.

**2-11. ELECTRICAL
REQUIREMENTS
OG-301/302/303**

- 120 V, 50/60 Hz., 12 A, 1 PH
- 230 V, 50/60 HZ., 6 A, 1 PH

The gas fry station requires a 3 wire grounded service.

WARNING

DO NOT DISCONNECT THE GROUND PLUG. This fry station MUST be adequately and safely grounded or electrical shock could result. Refer to local electrical codes for correct grounding procedures or in absence of local codes, with the National Electrical Code, ANSO/NFPA No. 70 Latest Edition. Canadian models are supplied with a terminal box, suitable for conduit connection. In Canada, all electrical connections are to be made in accordance with CSA C221, Canadian Electrical Code Part 1, and/or local codes.

Servicing of the filter pump is done at the rear of the unit. If service is required, disconnect the fry station from the electrical power source. The fry station will have to be pulled out from the wall to gain access to rear.

**2-12. ELECTRICAL
REQUIREMENTS
OE-301/302/303**

The OE-301/302/303 is available from the factory wired 208, or 220/240 volts, 50 or 60 hertz source. Refer to the table below for supply wiring and fusing.

Volts	Phase	KW	Amps
208	3	11.25	31
208	3	13.50	38
220/240	3	11.25	30/32
220/240	3	13.50	33/35
400	3	11.25	16
400	3	13.50	20

WARNING

This fry station must be adequately and safely grounded. Refer to local electrical codes for correct grounding procedures. If fry station is not adequately grounded, electrical shock could result.

A separate disconnect switch with proper capacity fuses or breakers must be installed at a convenient location between the fry station and the power source.

**2-13. TESTING
THE FRY STATION**

Each Henny Penny Fry Station was completely checked and tested prior to shipment. However, it is good practice to check the unit a again after installation.

SECTION 3. OPERATION

3-1. INTRODUCTION

This section provides operating procedures for the Henny Penny OG/OE-301/302/303. Sections 1, 2, and 3 should be read and all instructions should be followed before operating the fryer.

3-2. OPERATING CONTROLS

Figures 3-1 through 3-8 identify and describe the function of all operating controls and components.

Page 3-10 describes the function of electromechanical controls, or units without computer controls.

Fig. No.	Item No.	Description	Function
3-1	1	Power Switch	This two position rocker type switch controls the power to the fryer when in the on position.
3-1	2	Digital Display	The digital display is to show the shortening temperature, as well as the timer countdown in the frying cycle. The temperature of the shortening can be determined by depressing the temperature switch. If the temperature is below 250°F (121°C), the digital display will read "LO". If the temperature exceeds 390°F (199°C), the display will read "HI". Any temperature between these two settings will be displayed.
3-1	3	Timer Switch	The right timer can be activated or reset by gently depressing the timer switch. The same holds true for the left timer switch. The left display shows the left timer information and the right display shows the information for the right timer.
3-1	4	Set Switch	The set switch is used to set the cooking cycles and to enter the special program modes.
3-1	5	Exit Melt Switch	The exit melt switch is used to bypass the melt cycle. By pressing and holding the exit melt switch for five seconds, the heat will come on continuously.
3-1	6	Temperature Switch	By pressing the temperature switch (indicated by thermometer), the actual shortening temperature will show on the left display and the setpoint temperature on the right display.

3-2. OPERATING CONTROLS (Continued)

Fig. No.	Item No.	Description	Function
3-1	7	Melt LED	<p>When the melt LED is flashing, the fryer is in the melt cycle. When the temperature of the shortening reaches approximately 250°F (121°C), the melt LED will go off and automatically switch to the heat cycle.</p> <div style="text-align: center; border: 2px solid black; padding: 5px; width: fit-content; margin: 10px auto;"> WARNING </div> <p>When using solid shortening, it is recommended to melt the shortening on an outside heating source before placing shortening in the cookpots. Heating elements, and the slope of the gas cookpot must be completely submerged in shortening. Fire could result, or damage to the cookpot could result.</p>
3-1	8	Ready LED	The ready LED illuminates when the temperature of the shortening is near the setpoint temperature. (It will illuminate if the temperature is 5°F (or °C) more than the setpoint temperature.)
3-1	9	Heat LED	The heat LED illuminates when the heat comes on.
3-1	10	Product LED	The product LED flashes while in the program modes, and a new product can be selected at this time.
3-1	11	Time LED	The time LED flashes while in the program mode and a new fry time can be programmed.
3-1	12	Temperature LED	The temperature LED flashes while in the program mode and the setpoint temperature can be programmed.
3-1	13	Alarm LED	The alarm LED flashes while the program mode. Up to four alarms can be programmed in a cook cycle.

3-2. OPERATING CONTROLS (Continued)

Fig. No.	Item No.	Description	Function
3-1	14	Other LED	The other LED flashes while in the high level program mode and special program modes only. Several parameters can be programmed at this time.
3-1	15	Idle LED	The idle LED illuminates when the right timer up and down switch is pressed for two seconds. The indicator passes through the other product LEDs to the idle LED. The control will then regulate the shortening temperature at a lower programmed temperature.
3-1	16	Up and Down Switches	Two sets of up and down switches (denoted as triangles) are on the control. These switches are used in programming and product selection. A product is selected by pressing and holding either the up or down switch for two seconds. To select both the right and left products at the same time the programmed set point temperature must be the same.
3-2	17	Fuses (electric only)	The fuses, located on the panel behind door, are protective devices that break the circuit when the current exceeds the rated value. The 5 amp fuses provide an overload protection for the control panel.
3-2	18	High Limit Reset	This manual reset, located on panel behind door, must be pushed up in the event the high limit trips. This red button will manually reset the high limit. A high limit protects each cookpot.
3-3	19	Contactors (electric only)	The contactors are the relays that route power to the heating elements. One relay coil is in series with the high limit temperature control, and the other relay coil is in series with the heat control circuit, which is the mercury contactor.
3-3	20	Thermal Sensor	The thermal sensor, located behind the control panel, determines the shortening temperature.

**3-2. OPERATING CONTROLS
(Continued)**

Fig. No.	Item No.	Description	Function
3-4	21	Drain Interlock (Hidden behind bracket)	<p>The drain interlock switch is a microswitch that provides protection for the heating elements in the event an operator drains shortening from the frypot while the power switch is on. The drain switch is designed to automatically shut off the control system when the drain valve is opened. A drain interlock switch protects each cookpot.</p> <p style="text-align: center;">NOTE</p> <p>It is recommended to turn all power off before opening drain valve.</p>
3-5	22	Drain Valve	<p>The drain valve is a two-way ball valve and is normally in the closed position. Turn the handle to the open position to drain the shortening from the frypot.</p> <div style="text-align: center; border: 2px solid black; padding: 5px; width: fit-content; margin: 10px auto;"> <p>WARNING</p> </div> <p>Open the drain valve slowly to eliminate splashing of hot shortening. Severe burns could result.</p>
3-6	24	Filter Union	<p>The filter union connects the filter assembly to the filter pump. It is easily disconnected to allow removal of the filter and filter drain pan.</p>

3-2. OPERATING CONTROLS (Continued)

Fig. No.	Item No.	Description	Function
3-6	25	Filter Drain Pan	<p>The removable filter drain pan houses the filter and catches the shortening when it is drained from the frypot. It is not to be used to remove and discard the shortening when the shortening needs replaced.</p> <div style="text-align: center; border: 2px solid black; padding: 5px; width: fit-content; margin: 10px auto;"> WARNING </div> <p>Use extreme care when handling the drain pan or any metal which comes in contact with hot shortening. Do not move drain pan with hot shortening in pan. Severe burns could result. It is recommended to use gloves.</p>
3-6	26	Filter Pump Switch	This two position rocker switch controls the power to the filter pump motor.
3-6	27	Oil Return Line	The detachable oil return line pivots to reach all three cookpots when pumping shortening back into the cookpots. The return line can be removed and a rinse hose connected to unit to discard shortening from unit.
3-8	28	Gas Shut-Off Valve (gas only)	Each cookpot has its own gas shut-off valve on the gas line going to the gas valve.
3-8	29	Gas Control Valve (gas only)	Each cookpot has its own gas control valve which controls the flow of gas to burner assembly. It requires manual pilot lighting.
3-8	30	Gas Solenoid (gas only)	The gas solenoid shuts the flow of gas off to the burner in this unit that the high limit kicks out, and is present for each cookpot.

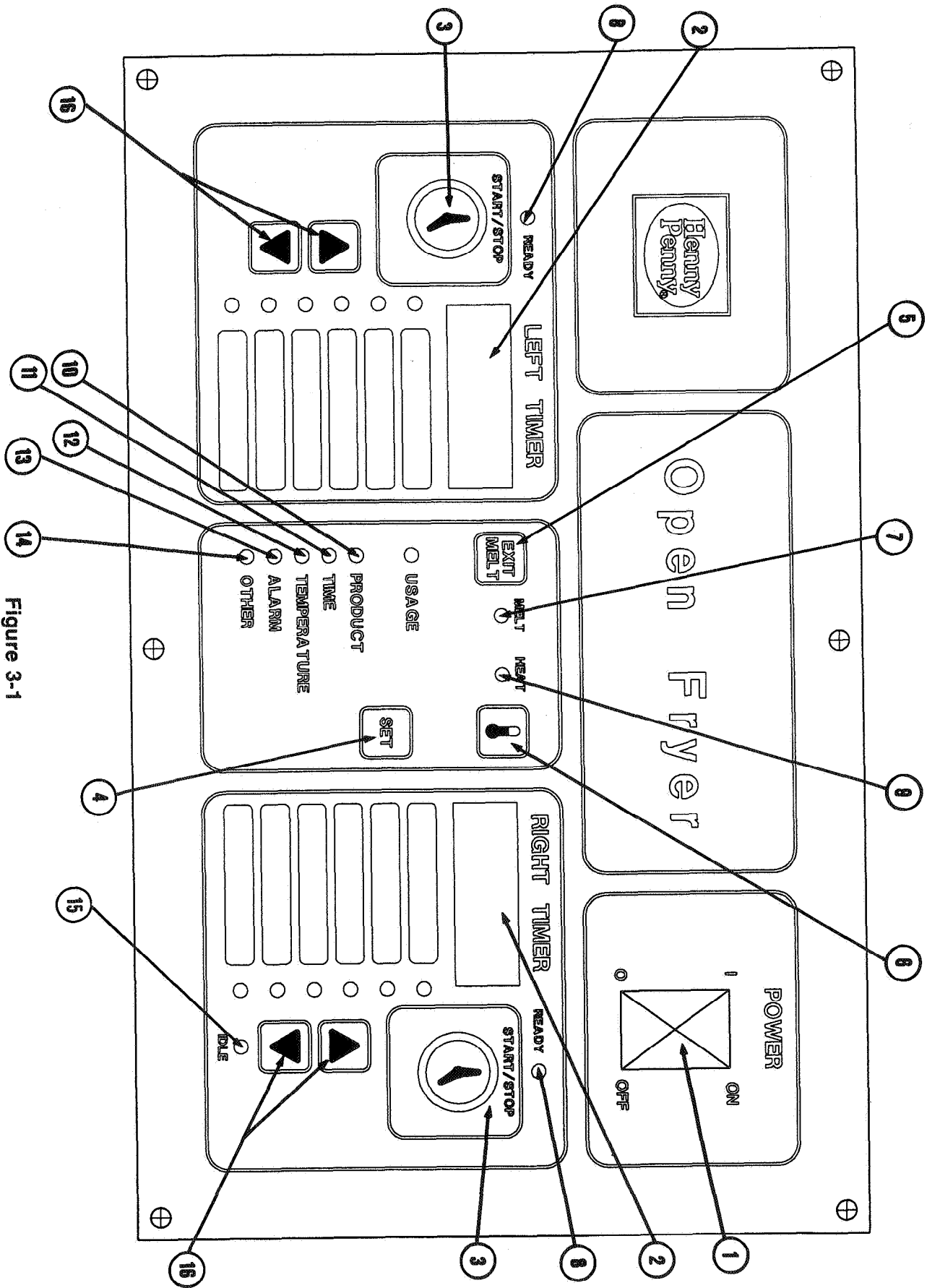

Figure 3-1

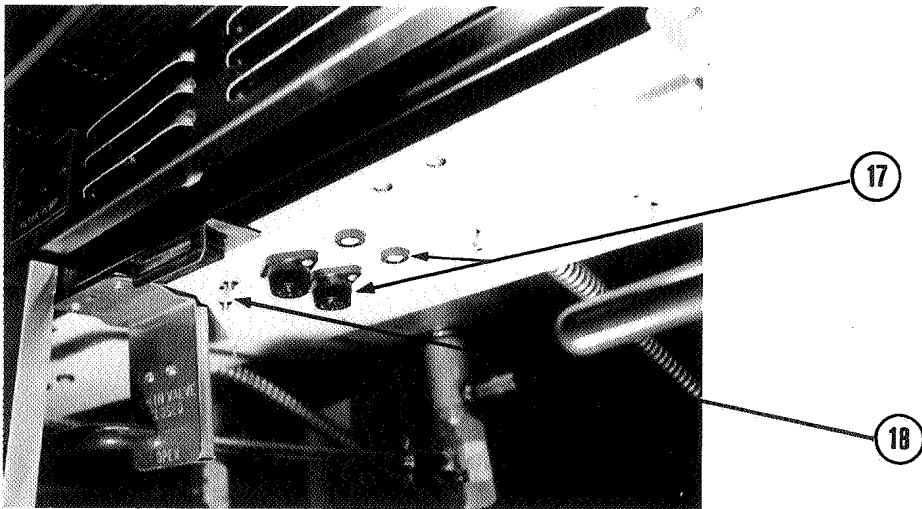

Figure 3-2

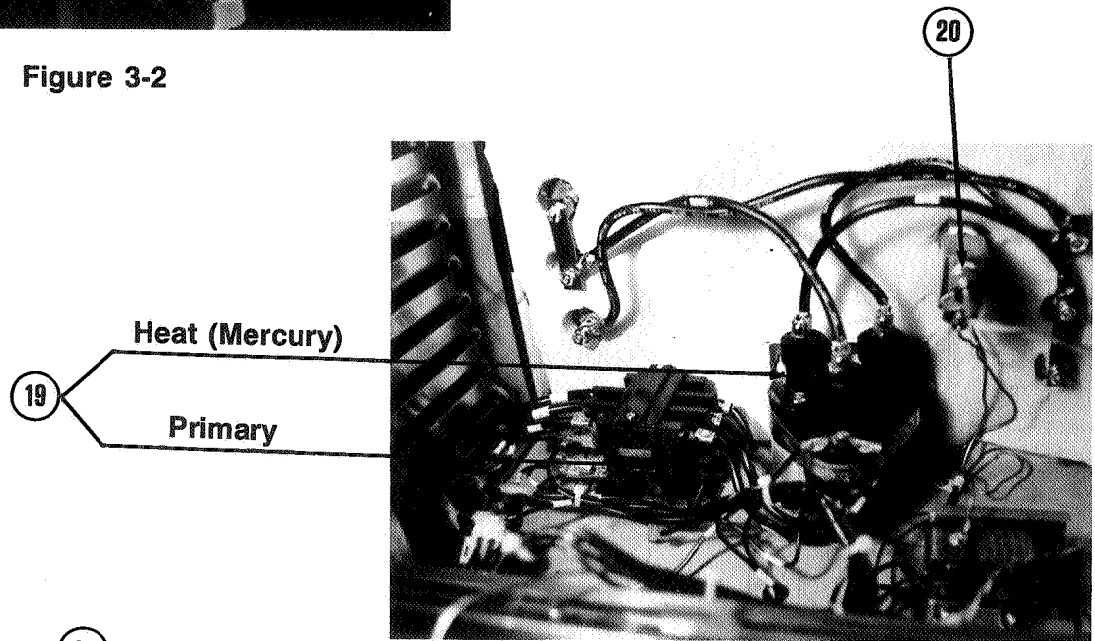

Figure 3-3

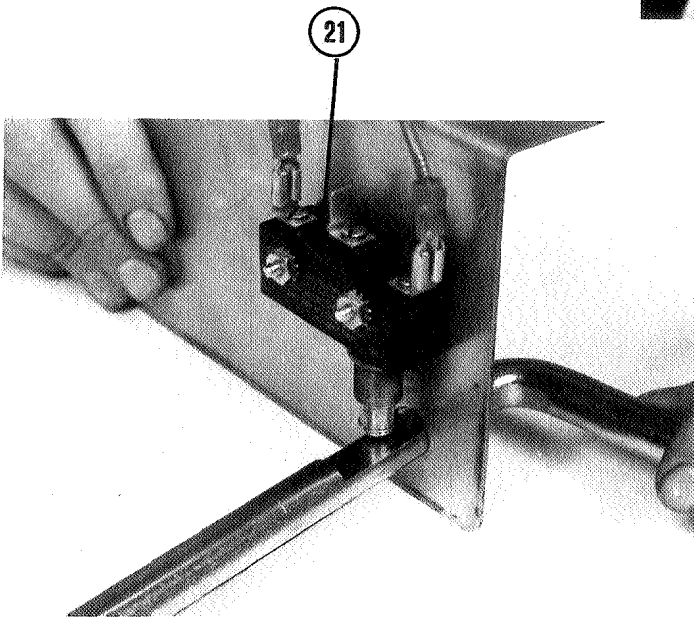

Figure 3-4

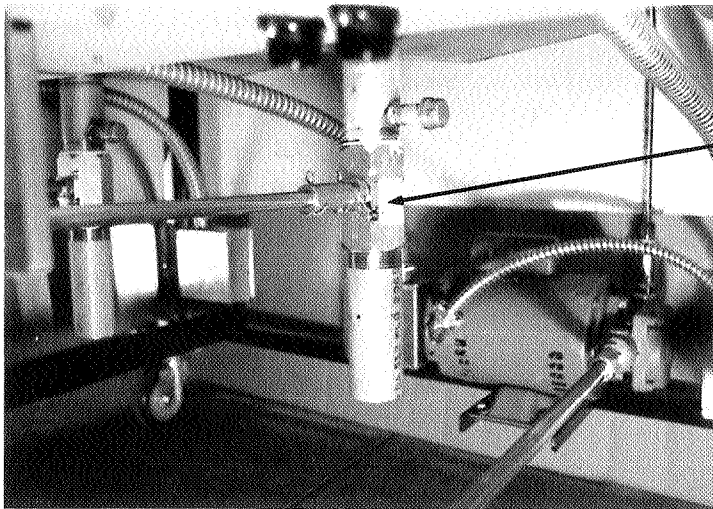

Figure 3-5

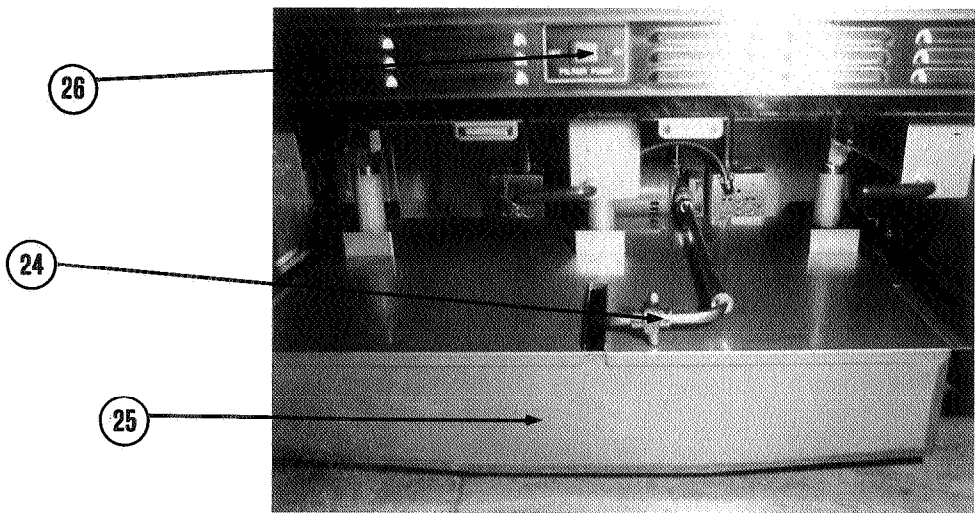

Figure 3-6

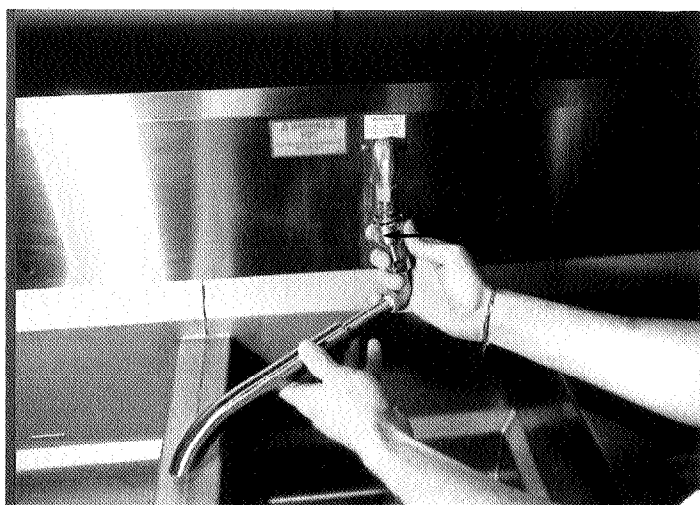

Figure 3-7

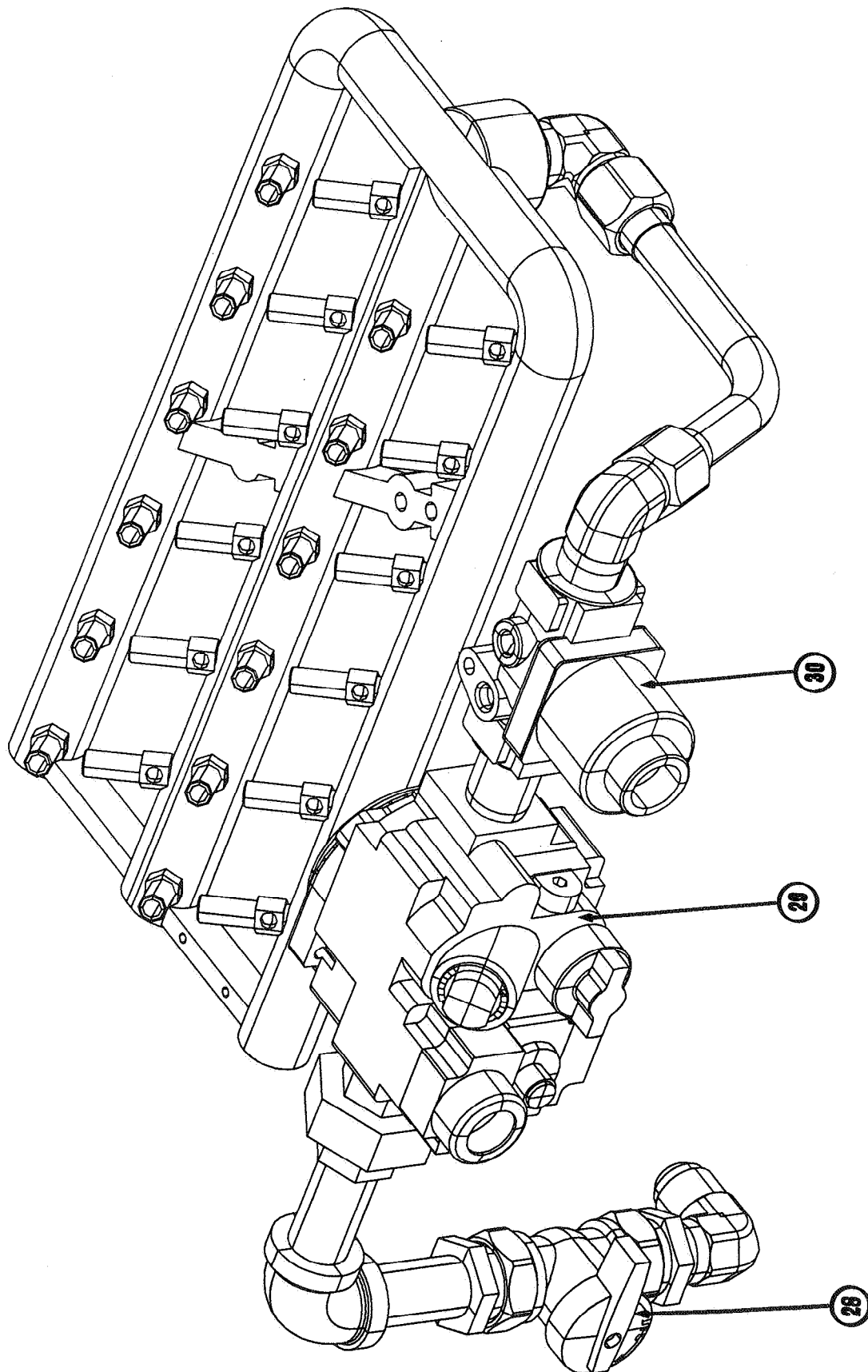
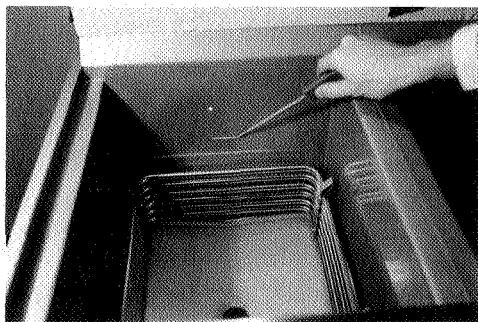

Figure 3-8

ELECTROMECHANICAL CONTROLS

ITEM	DESCRIPTION	FUNCTION
1	Main Power Switch	The main power switch is a two-way switch. Move the switch to the position marked ON to operate the fryer.
2	PUMP Switch	Move the switch to the position marked ON to operate the filter pump.
3	Thermostat Standard (TEMPERATURE)	The thermostat is an electro-mechanical device used to regulate temperature. Turn the knob to set the desired frying temperature.
4	TEMPERATURE Light	The temperature light is illuminated while the shortening is below the temperature set by the thermostat. It goes off when the shortening reaches the set temperature.
5	TIMER	The timer is an electro-mechanical device that controls the length of the frying cycle and activates the buzzer when the frying cycle is complete. Turn the knob to set the black arrow at the desired frying time. The red arrow will reset back to the black arrow when the ON/OFF switch is moved to OFF.
6	TIMER/ON/OFF Switch	Move the switch to the ON position to start the timer. Move to the OFF position to stop the buzzer after the frying cycle. This also will reset the timer to the original setting.
7	TIMER Light	The timer indicating light is a red light which is illuminated when the timer is on.

3-3. FILLING OR ADDING SHORTENING



It is recommended that a high quality frying shortening be used in the OE-301/302/303 and OG-301/302/303 fry stations. Some low grade shortenings have a high moisture content causing foaming and boiling over. The Henny Penny OE-301/302/303 requires 48 pounds of shortening per cookpot. The OG-301/302/303 requires 43 pounds per cookpot. All cookpots have two level indicators inscribed on the rear of the cookpot wall. The top indicator shows when the heated shortening is at the proper level. Cold shortening should be at the bottom indicator, since the shortening will expand when heated.

WARNING

Hot shortening must be maintained at the level indicator on each cookpot, or fire could result. It is also recommended to use gloves when in contact with hot shortening. Shortening and all metal parts that are in contact with the shortening are extremely hot and severe burns could result.

Moving the fryer with hot shortening in the cookpots or filter pan is not recommended. Hot shortening can splash out and severe burns could result.

3-4. OPERATING CONTROLS AND PROCEDURES

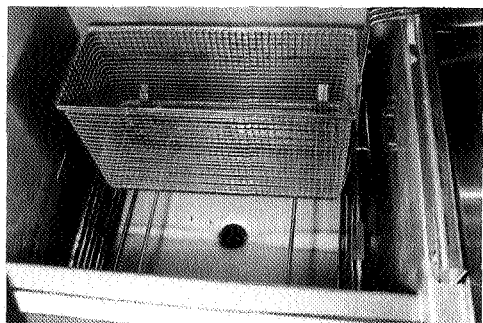

The Henny Penny Open Fry Station with dual timers contains solid state controls for each cookpot. The following is brief description of the operating procedures.

1. Be sure the drain valve is in the closed position.
2. Place basket support inside of cookpot.
3. Fill the cookpot with shortening.

WARNING

When using solid shortening, it is recommended to melt the shortening on an outside heating source before placing it in the cookpots. Heating elements and the slope of the gas cookpot must be completely submerged in shortening. Fire could result, or damage to the cookpot could result.

3-4. OPERATING CONTROLS AND PROCEDURES (Continued)

4. Move power switch to the "ON" position. Unit will automatically go into the melt cycle. When the temperature reaches 250°F (121°C) the control will go into the heat cycle. The shortening will be heated until the temperature setting is reached.

NOTE

The melt cycle may be bypassed, if desired, by pressing the Exit Melt switch and holding it for five seconds.

WARNING

Do not bypass the melt cycle unless enough shortening has melted to completely cover all of the heating elements. If melt cycle is bypassed before all heating elements are covered, excessive smoking of the shortening or a fire will result.

5. Press the up or down switch and hold for two seconds to select a product. The times and temperatures are preprogrammed.

NOTE

The operation of the two timers is entirely independent. They may be set, started, or stopped without affecting each other.

6. Thoroughly stir shortening to stabilize the temperature throughout the cookpots.
7. When the shortening temperature has reached setpoint, ready LED will illuminate, indicating to the operator, they may drop product.
8. Lower basket with product into cookpot and press timer switch. Countdown will begin.
9. When frying cycle is complete, a pulsating beep will sound and the display will read "DONE." Pressing the timer switch stops the beeping and starts the hold mode.
10. The baskets can be lifted out to drain for the duration of the hold mode, the display will flash 00:00 and a pulsating beep will sound. Pressing the timer switch resets it back to the cooking time.

3-5. FILTERING OF SHORTENING

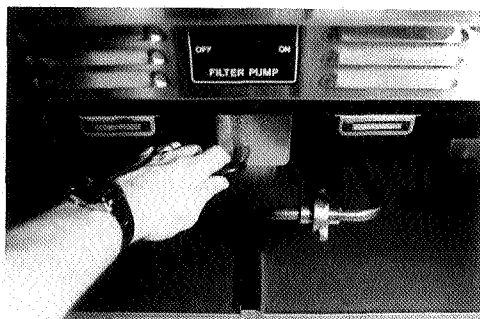

Frying breaded food requires frequent filtering. Taste the cold shortening every day for flavor. Watch the shortening for foaming during the frying cycle. Discard the shortening as soon as it shows sign of foaming. Clean the cookpot as follows each time the shortening is changed or filtered.

1. Turn the main switch to the OFF position. Remove and clean the fry basket in soap and water. Rinse thoroughly.

NOTE

Best results are obtained when shortening is filtered at the normal frying temperature.

2. Use a metal spatula to scrape any build up from the sides of the cookpot. Do not scrape heating elements on electric models, or the slope on the gas models.

WARNING

The filter pan must be in the proper position beneath the drain valve. This will prevent the splashing of shortening on the floor. This splashing could result in severe burns.

3. Open door(s) under unit and open the drain valve very slowly, half a turn at first and then slowly to the full open position. This will prevent excessive splashing of the hot shortening as it drains into the filter drain pan.
4. As the shortening drains from the cookpot, use brushes to scrape and clean the side of the cookpot and the heating elements of the electric model. If the drain fills with breading, use straight white brush to push excess breading into the drain pan.
5. When all of the shortening has drained, scrape or brush the sides and the bottom of the cookpot.
6. Rinse the cookpot as follows:
 - a. Close the drain valve.
 - b. Position return line over empty cookpot.
 - c. Move the pump switch to the pump position.
 - d. Fill the cookpot 1/3 full, then turn off pump.

3-5. FILTERING OF SHORTENING (Continued)

WARNING

If shortening is slow coming from faucet, it is possible that the filter connecting the union on the filter tube line is not tightened properly. If so, turn off the pump and use gloves to tighten the union. This union will be hot. Severe burns could result.

- e. Wash down and scrub the sides of the frypot.
 - f. After the sides and bottom are cleaned, open the drain valve.
7. Pump all of the shortening out of the filter pan and back into the cookpot.
 8. When the pump is pumping air only, move the pump switch from PUMP to OFF.
 9. Check the level of the shortening in the cookpot. Add fresh shortening if necessary, until it reaches the level indicator line on the rear wall of the cookpot.

NOTE

Approximately 10 to 12 filterings can be made with one filter paper envelope, depending on several conditions; the quantity and type of product fried and filtered, the type of breading used, and the amount of crumb accumulation left inside the filter drain pan. When the filter screen assembly and filter paper become clogged and the pumping flow rate slows down, clean the screen assembly and change the filter envelope.

10. If frying is to be continued at this time, move the main power switch back to the "ON" position, and allow time for reheating of the shortening.

3-6. FILTER PUMP PROBLEMS

The following steps will help prevent filter pump problems.

1. Make certain the filter paper envelope is properly installed over the filter screens. Make sure the open end of the envelope is properly folded over and clamped in place with the retaining clips so that the envelope is sealed and crumbs cannot enter.
2. Make sure all the shortening has been pumped from the filter lines and the pump by allowing the filter pump motor to run until no shortening is coming from the nozzle.

3-7. FILTER PUMP MOTOR PROTECTOR

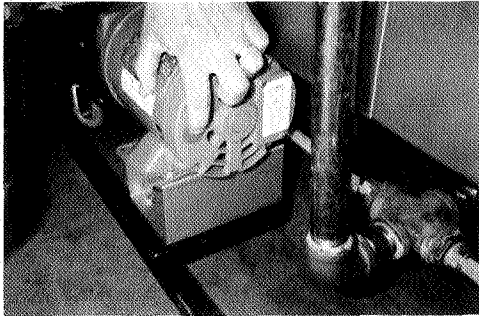

The filter pump motor is equipped with a manual reset button in the event the motor's thermal protector activates. This reset button is located on the rear of the motor. Wait approximately 5 minutes before attempting to reset this protector device.

WARNING

To prevent burns caused by splashing shortening, the unit's filter pump switch must be in the OFF position before resetting the filter pump motor's manual reset protector device.

NOTE

The reset button will take some effort to reset. A screwdriver could be used to press against the reset button to aid in resetting the protector device.

3-8. CHANGING THE FILTER ENVELOPE

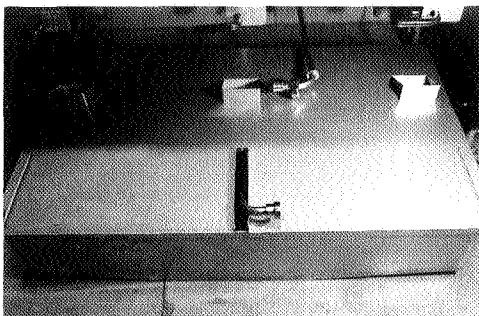

The filter envelope should be changed after 10-12 filterings or whenever it becomes clogged with crumbs. Proceed as follows:

1. Move the main power switch to the OFF position.
2. Disconnect the filter union and remove the filter drain pan from beneath the cookpot.

WARNING

This union may be hot. Use protective gloves or clothes to prevent burns. Also use care to prevent burns caused by splashing of hot shortening.

3. Remove drain pan cover from drain pan and lift the screen assembly from the drain pan.
4. Wipe the shortening and crumbs from the drain pan. Clean the drain pan with soap and water. Thoroughly rinse with hot water.
5. Unthread the suction standpipe from the screen assembly.
6. Remove the crumb catcher and clean thoroughly with soap and water. Rinse thoroughly with hot water.
7. Remove the filter clips and discard the filter envelope.

3-8. CHANGING THE FILTER ENVELOPE (Continued)

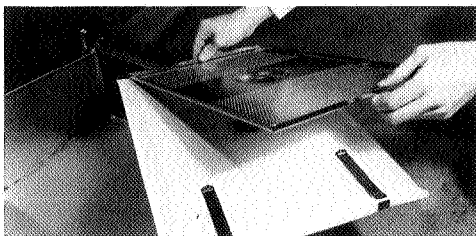
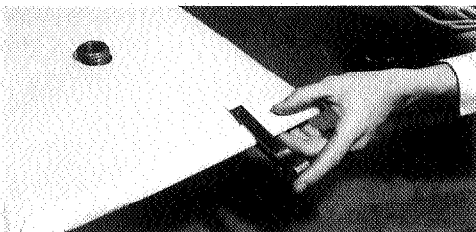
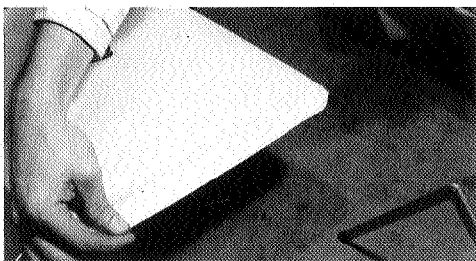
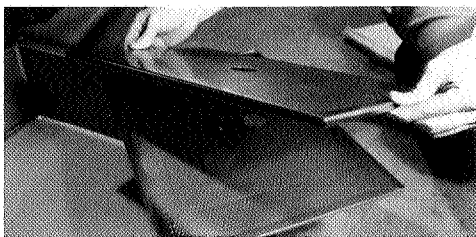
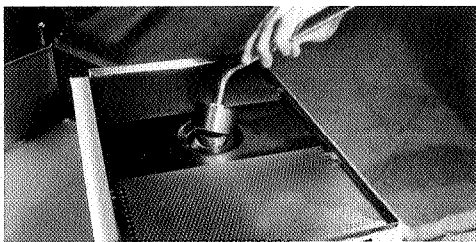
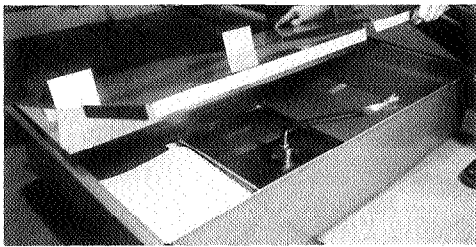

8. Clean the top and bottom filter screen with soap and water. Rinse thoroughly with hot water.

CAUTION

Be sure that the filter screens, crumb catcher, filter clips and the suction standpipe are thoroughly dry before assembly of filter envelope or water will dissolve the filter paper.

9. Assemble the top filter screen to the bottom filter screen.
10. Slide the screen into a clean filter envelope.
11. Fold the corners in and then double fold the open end.
12. Clamp the envelope in place with the two filter retaining clips.
13. Replace the crumb catcher screen on top of the filter paper. Screw on the suction standpipe assembly.
14. Place complete filter screen assembly back into filter drain pan, replace cover, and slide pan back into place beneath the fryer.
15. Connect the filter union by hand. Do not use a wrench to tighten.
16. The fryer is now ready to operate.

3-9. CLEANING THE COOKPOTS

After the initial installation of the fryer, as well as before every change of shortening, the cookpot should be thoroughly cleaned as follows:

NOTE

Melt bypass should be in operation. Refer to section 3-2 "Operating Controls" on Exit Melt Switch.

1. Turn the main power switch OFF.

WARNING

The filter drain pan must be in position under the drain valves to prevent splashing or spilling of hot liquids which can cause serious burns.

2. If hot shortening is present in the cookpot, it must be drained by slowly opening the drain valve handle one half turn. Leave for a few minutes, then slowly open the valve to full open position.
3. Close the drain valve. Discard the shortening in the filter pan using the shortening shuttle. Then install the filter drain under the fryer, leaving out the filter screen assembly.

WARNING

Moving the fry station, or drain pan, with hot shortening in them is not recommended. Hot shortening can splash out, and severe burns could result.

4. Fill the cookpot to the level indicator with hot water. Add 4 ounces of fryer cleaner to the water and mix thoroughly. The fry basket can be placed inside the cookpot for cleaning.

WARNING

Always wear chemical splash goggles or face shield and protective rubber gloves when cleaning the cookpot as the cleaning solution is high in alkaline. Avoid splashing or other contact of the solution with your eyes or skins. Severe burns may result. Carefully read the instructions on the cleaner. If the solution comes in contact with your eyes rinse thoroughly with cool water and see a physician immediately.

5. Turn the main power switch to the POWER position and set temperature to 200°F. The Exit Melt Switch must be used.

3-9. CLEANING THE COOKPOTS (Continued)

6. When the solution reaches 200°F, turn the main power switch to the OFF position.

CAUTION

Watch cleaning solution constantly to make sure it does NOT boil over, causing damage to controls.

7. Let the cleaning solutions stand for 15 to 20 minutes with the power off.
8. Using the fryer brush (never use steel wool), scrub the inside of the cookpot.
9. After cleaning, open the drain valve and drain cleaning solution from the cookpot into the drain pan and discard.
10. Replace the empty drain pan, close the drain valve, and refill the cookpot with plain hot water to the proper level.
11. Add approximately 8 ounces of distilled vinegar and bring the solution back up to 200°F (93°C).
12. Using a clean brush, scrub the interior of the cookpot. This will neutralize the alkaline left by the cleaning compound.
13. Drain the vinegar rinse water and discard.
14. Rinse down the cookpot using clean, hot water.
15. Thoroughly dry the drain pan and the cookpot interior.

NOTE

Make sure the inside of the cookpot, the drain valve opening, and all the parts that will come in contact with new shortening are as dry as possible.

16. Replace the clean filter screen assembly in the drain pan, replace cover, and install drain pan under fryer.
17. Refill the cookpot with fresh shortening.

SECTION 4. PROGRAMMING

The controls have four programming levels, a first level mode, a second level mode, a third level mode, and a special program mode. In each level, pressing the set switch advances through the programmable items. Program mode can be entered at anytime except during an alarm. The left display describes the item being programmed. The right display shows the item setting and can be changed by pressing the right Up and Down Switches.

**4-1. FIRST LEVEL
PROGRAM MODE**

The Low Level Program Mode allows the operator to program the "global" set point temperature (if enabled), cook and hold time, and set up to four alarms for the selected product.

1. Press and hold Set and Temperature Switch for at least five seconds. A tone will sound, and the left display shows "°F" and the right display shows the set point temperature. The temperature LED and all product indicator LED's flash.
2. Press the right Up and Down Switches to program desired set point temperature for all products.
3. Press the set switch and left display shows "Slct" and the right display shows "Prod". The product LED also flashes.
4. Press either the left or right Up and Down Switches to select a product to program, and the LED will be lit next, to the desired product.
5. Press the set switch and the time LED flashes. The left displays shows "Fry" and the right display shows the cook time. Pressing the right Up and Down Switches adjusts the cook time.
6. Press the set switch and the time LED continues to flash. The left display shows "Hold," the right display shows the hold time and can be adjusted with the right Up and Down Switches.

**4-1. LOW LEVEL
PROGRAM MODE
(Continued)**

7. Press the set switch and the alarm LED flashes. The left display shows "AL 1", the right display shows the alarm time and can be adjusted with the right Up and Down Switches.
8. Repeat step 8 for alarms 2, 3, and 4.
9. Press and hold the Set Switch to exit program mode, or continue to second level mode.

**4-2. SECOND LEVEL
PROGRAM MODE**

The Second Level Program Mode allows the operator to program load compensation, load anticipation, proportional control, filter cycle for the selected product, and the idle parameters.

1. While in the first level mode, push and hold the Set and Exit Melt Switches for five seconds. The beeper will sound the left display will show "Slct" (Select) and the right display will show "Prod" (Product). The Product LED also flashes.
2. Press either the right or left Up and Down Switches to select a product to program.
3. Press Set Switch and the Other LED flashes. The left display shows "LdCo," and the right display shows load compensation setting, and can be adjusted with the right Up and Down Switches.
4. Press the Set Switch and the Other LED continues to flash. The left display shows "PC," the right display shows the proportional control setting, and can be adjusted with the right Up and Down Switches.
5. Press the Set Switch and the Other LED continues to flash. The left display shows "LdAn," and the right display shows load anticipation setting, and can be adjusted with the right Up and Down Switches.
6. Press the Set Switch and the Other LED continues to flash. The left display shows "Filtr," and the right display shows filter cycles setting, and can be adjusted with the right Up and Down Switches.
7. Press the Set Switch and the Product LED flashes. Press either right or left Up and Down Switches to select another product to program. Press and hold the Set Switch to exit the program mode, or continue on to the third level program mode.

**4-2. SECOND LEVEL
PROGRAM MODE
(Continued)**

8. Also, with the Product LED flashing, pressing the right Up and Down Switches will access the Idle Mode parameters. The idle LED will be flashing, the left display will continue to show "Slet" and the right display shows "Prod." Pressing the Set Switch allows the operator to program the idle parameters (See Section 4-3).

4-3. IDLE PROGRAMMING

The Idle Mode must be enabled for the operator to access this mode.

1. While in the Second Program Mode, and the Product LED is flashing, press the right Up and Down Switches to select the idle mode items. The Idle LED will be flashing.
2. Press the Set Switch and the Time LED flashes, the left display shows "idle," and the right display shows "ON or OFF". Pressing the right Up and Down Switches to turn idle on or off.
3. Press the Set Switch and the Time LED flashes. The left display shows "Auto" and the right display shows automatic idle time. Adjust the automatic idle time with the right Up and Down Switches, and to disable the auto idle feature set time to "OFF."
4. Press the Set Switch and the Temperature LED flashes. The left display shows "F" or "C", and the right display shows the idle temperature setpoint, which can be adjusted with the right Up and Down Switches.
5. Press Set Switch and the Product LED flashes. Press and hold the Set Switch to exit the program mode or continue to the third level program mode.

**4-4. THIRD LEVEL
PROGRAM MODE**

The Third Level Program Mode allows the operator to enable, or disable "global" setpoints, program Fahrenheit or Celcius, probe calibration, alarm duration, and hold duration.

1. While in the third level program mode, press and hold Exit Melt and Temp switches until the buzzer sounds, and the left display flashes "glob" and °F", and the right display shows "ON" or "OFF." Pressing the right Up and Down Switches enables, or disables the global setpoint programming.
2. Press the Set Switch and the left displays shows "deg" and the right display shows "°F" or "°C." Pressing the right Up and Down Switches allows the operator to select Fahrenheit, or Celcius.

4-4. THIRD LEVEL PROGRAM MODE
(Continued)

3. Press the Set Switch and the left display flashes "Prob" and "Calib." The right display shows the actual pot temperature, and the right Up and Down Switches are used for calibration.
4. Press the Set Switch and the left display flashes "AL" and "dur." The right display shows the duration of this alarm at the end of a cook cycle, and can be adjusted with the right Up and Down Switches.
5. Press the Set Switch and the left display flashes "Hold" and "dur." The left display shows the duration of the hold alarm at the end of the hold cycle, and can be adjusted with the right Up & Down Switches.
6. Press and hold the Set Switch to exit the program mode.

4-5. SPECIAL PROGRAM MODE

The Special Program Mode allows the operator to initialize the program, or to perform an input/output test.

1. Turn Power Switch off, then press and hold the right Up and Down Switches while turning power switch back on. The left display shows "init" and the right displays shows "sgs." Press and hold the right Up or Down Switch for five seconds to initialize all settings. Special Program Mode is automatically exited if initialize is done.
2. While in the Special Program Mode, press the Set Switch and the left display shows "10" and the right display shows "test," then they go blank. By pressing all switches, enables all LED's and displays. Pressing temp. switch turns on heat. Press and hold Set Switch exits Special Program Mode.

SECTION 5. TROUBLESHOOTING

5-1. INTRODUCTION

This section provides troubleshooting information in the form of an easy-to-read table.

If a problem occurs during the first operation of a new fryer, recheck the installation per Section 2 of this manual.

Before troubleshooting, always recheck the operating procedure per Section 3 of this manual.

5-2. TROUBLESHOOTING

In the event of a control system failure, the digital display will show an "Error Message." These messages are coded: E5, E4, E6, E10, E15, E41, E50, E51, and E53.

DISPLAY	CAUSE	PANEL BOARD CORRECTION
E5	Shortening Overheating	Turn switch to OFF position, then turn switch back to ON. If display shows E5, the heating circuits and temperature probe should be checked.
E4	Control Board Overheating	Turn switch to OFF position, then turn switch back to ON. If display shows E4, the control board is getting too hot. Check the louvers on each side of the unit for obstructions. If E4 persists, replace control panel.
E6	Thermal Sensor Failure	Turn switch to OFF position, then turn switch back to ON. If display shows E6, thermal sensor must be replaced. Refer to section 6-4.
E10	High Limit Failure	Reset high limit by manually pushing up on the red reset button. If high limit does not reset, high limit must be replaced per section 6-5, or 6-6.
E15	Drain Switch Failure	Close drain, using the drain valve handle. If display still shows E15 check drain valve section 6-13.
E41, E50, E51, E53	Programming Failure	Turn switch to OFF, then back to ON. If display shows any of the error codes, the control panel needs replaced.

5-2. TROUBLESHOOTING
(Continued)

PROBLEM	CAUSE	POWER CORRECTION
With switch in POWER position and switch light not illuminated, fryer is completely inoperative.	Open Circuit	<ul style="list-style-type: none"> • Check to see if unit is plugged in. • Check breaker or fuse at supply box. • Check control panel fuse per Section 6-12. • Check POWER switch per Section 6-14. Replace if defective. • Check voltage at wall receptacle. • Check cord and plug.
With switch in power position, switch light is on, but all other lights are out except the pump will operate.	No power to board	<ul style="list-style-type: none"> • Check fuse on PC board.
Shortening will not heat but lights are on.	<p>Faulty Contactor (elec. model)</p> <p>Faulty Gas Valve (gas model)</p> <p>Faulty Gas Solenoid (gas model)</p> <p>Faulty Probe</p> <p>Faulty High Limit</p> <p>Faulty Drain Switch</p>	<ul style="list-style-type: none"> • Check contactor per Section 6-8. • Check gas valve per Section 6-11. • Check gas solenoid, per Section 6-19. • Check probe per Section 6-4. "Error message" E6. • Check High Limit per Section 6-6, or 6-7. "Error message" E10. • Check drain switch per Section 6-13. "Error message" E15.

5-2. TROUBLESHOOTING (Continued)

PROBLEM	CAUSE	POWER CORRECTION
Shortening will not heat, but lights are on.	Faulty Contactor (elec. model) Faulty Thermal Sensor Faulty High Limit	<ul style="list-style-type: none"> • Check contactor per Section 6-8. • Check thermal sensor per Section 6-4. "Error message" E6. • Check high limit control switch per Section 6-6 or 6-7.
A. Pilot will not light (gas model)	Pilot not lit Plugged pilot orifice, and/or pilot supply tube Gas supply off Faulty gas control valve Air in gas supply line	<ul style="list-style-type: none"> • Light pilot per Section 2-9. • Unplug pilot orifice and/or pilot supply tube. • Turn ON gas supply. • Replace gas control valve. • Bleed air from supply line.
B. Pilot will not stay lit.	Faulty thermo couple Pilot magnetic plug	<ul style="list-style-type: none"> • Replace thermo couple per Section 6-10. • Service per Section 6-11.
C. Burner will not light, pilot lit (gas model)	Drain valve open High Limit control switch open Possible faulty gas control valve	<ul style="list-style-type: none"> • Close drain valve. • With power removed from fryer, check across high limit switch terminals with ohmmeter. Replace if no reading is indicated on meter. • With power removed from fryer, check across electrical leads of gas control valve with ohmmeter, and gas valve in "ON" position. Ohm reading should be 234 ohm resistance. Replace the control valve if not within 10%.

5-2. TROUBLESHOOTING (Continued)

PROBLEM	CAUSE	POWER CORRECTION
Heating of shortening too slow	<p>Low or improper voltage (elec. model)</p> <p>Weak or burnt out elements (elec. model)</p>	<ul style="list-style-type: none"> • Use a meter and check the receptacle against data plate. • Check heating elements per section (elec. model).
Heating of shortening too slow (elec. model)	<p>Points in contactor bad (elec. model)</p> <p>Wire(s) loose</p> <p>Burnt or charred wire connection</p> <p>Supply line too small - low gas volume (gas model)</p> <p>Incorrect jet size (gas model)</p> <p>Improper ventilation system (gas model)</p>	<ul style="list-style-type: none"> • Check contactor per Section 6-8. • Tighten • Replace wire and clean connectors. • Increase supply line size. Refer to installation instructions. • Replace with proper size jet for type of gas. • Refer to Section 2-5.
Shortening overheating	<p>Check probe calibration</p> <p>Check contactor for not opening (elec. model)</p> <p>Bad Controller</p>	<ul style="list-style-type: none"> • Calibrate probe if $\pm 10^{\circ}\text{F}$ or $^{\circ}\text{C}$ off. If more than $\pm 10^{\circ}\text{F}$ or $^{\circ}\text{C}$, replace probe. • Replace control board if heat indicator stays on past ready temperature.

5-2. TROUBLESHOOTING (Continued)

PROBLEM	CAUSE	POWER CORRECTION
Foaming or boiling over of shortening.	Water in shortening Improper or bad shortening Improper filtering Improper rinsing after cleaning the fryer	<ul style="list-style-type: none"> • At end of frying cycle, drain shortening and clean frypot. Add fresh shortening. • Use recommended shortening. • Refer to the procedure covering filtering the shortening. • Clean and rinse the frypot. Then dry thoroughly.
Shortening will not drain from frypot	Drain valve clogged with crumbs Drain valve will not open by turning handle	<ul style="list-style-type: none"> • Open valve force cleaning brush through drain opening. • Replace cotler pins in in valve capling.
Filter motor runs but pumps shortening slowly	Filter valve not open Pump clogged Filter line connection loose Solidified shortening in lines	<ul style="list-style-type: none"> • Open filter valve. • Remove and clean pump per Section 6-15. • Tighten all filter line connections. • Clear all filter lines of solidified shortening.
Filter switch ON, motor does not run	Defective switch Defective motor Motor thermal protector tripped	<ul style="list-style-type: none"> • Check/replace switch per Section 6-15. • Check/replace motor per Section 6-15. • Reset thermal switch per Section 3-7.
Motor hums but will not pump	Clogged lines or pump	<ul style="list-style-type: none"> • Remove and clean pump and lines. • Replace pump seal, rotor and rollers per 6-15.



SECTION 6. MAINTENANCE

6-1. INTRODUCTION

This section provides procedures for checking and replacement of the various parts used within the unit. Before replacing any parts, refer to Section 5, Troubleshooting. It will aid you in determining the cause of a particular malfunction.

6-2. TEST INSTRUMENTS

You may want to use two test instruments to check the electric components.

- A continuity light
- An ohmmeter

When the manual refers to a circuit being closed, the continuity light will be illuminated or the ohmmeter should read (0) unless otherwise noted.

When the manual refers to the circuit being open, the continuity light will not illuminate, or the ohmmeter will read (1).

NOTE

A continuity light cannot be used to check coils or motors.

6-3. REMOVING THE CONTROL PANEL

To replace parts located inside the fryer, the control panel must be removed, or hinged down.

1. Place the power switch in the OFF position and remove power supplied to the unit, or on electric models, to the cookpot to be worked on.

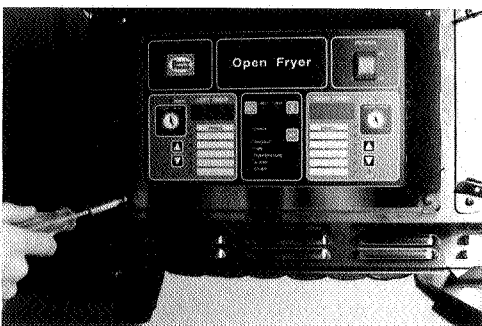

WARNING

Disconnect power supplied to the unit by unplugging the power cord, or turning off the wall circuit breaker, or fuse. Be aware that the other controls will HAVE power on electric models, or electrical shock could result.

6-3. REMOVING THE CONTROL PANEL (Continued)

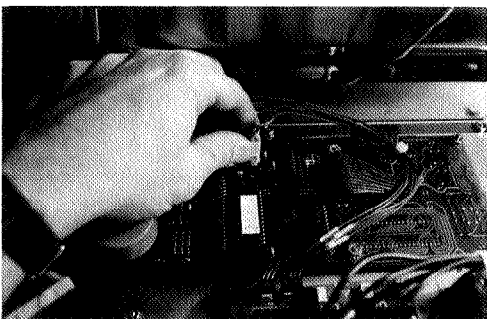
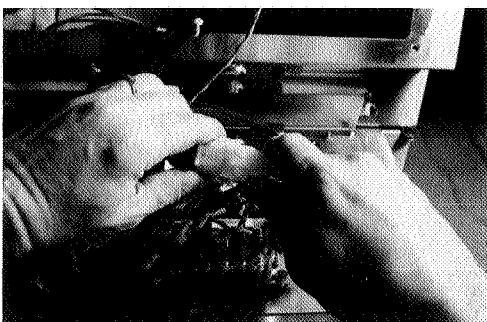
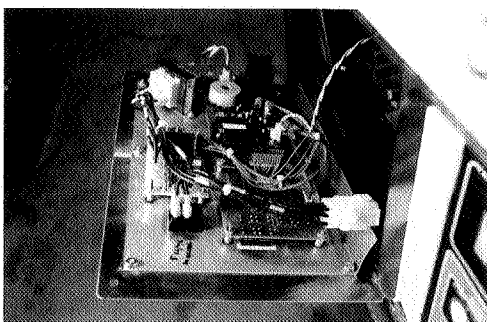

2. Using a Phillips head screwdriver, remove the four screws securing the control panel to the unit, and let panel swing down. The panel is hinged to hang in this position for convenience.

3. Disconnect nine-pin connector and remove probe connection from control panel.

4. To completely remove panel from unit, pull complete control panel up and out of slots securing the panel.

6-4. THERMAL SENSOR (Probe)

The thermal sensor, or probe, determines the shortening temperature. If a malfunction does occur, an E6 will be displayed on the digital display. Turn unit OFF, then back on. If E6 persists, the probe must be checked, or replaced by the following steps:

1. Place the power switch in the OFF position, and remove power supplied to the unit, or on electric models, to the cookpot to be worked on.

6-4. THERMAL SENSOR (Continued)

Checkout

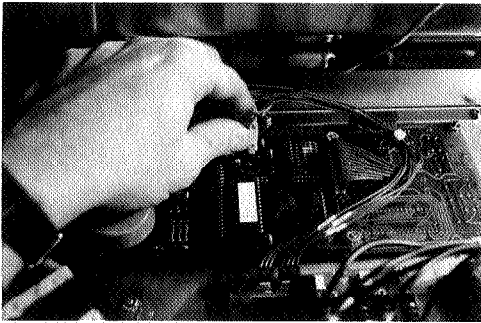

Replacement

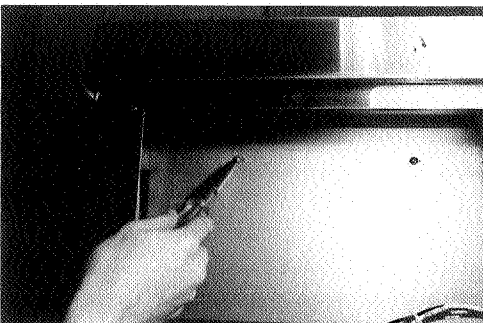
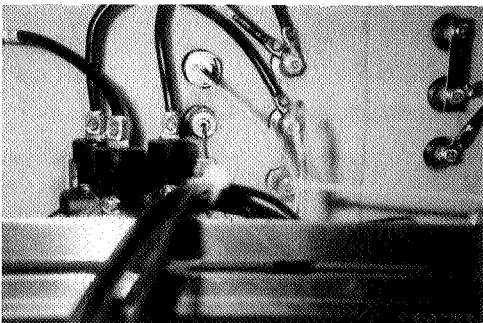

WARNING

Disconnect power supplied to the unit by unplugging the power cord, or turning off the wall circuit breaker, or fuse. Be aware that the other controls will **HAVE** power on electric models, or electrical shock could result.

2. Swing control panel down per section 6-3.
3. Inspect the probe connection at the board, making sure of a good connection.
4. Replace control panel, reconnect power supply and turn power switch to on position. If E6 persists continue on to step 5.

5. Disconnect power to unit and remove control panel per section 6-3.
6. Drain the shortening from cookpot (electric units continue to step 8).
7. Remove heat shield from unit.
8. Using a 1/2" wrench, loosen nut on compression fitting and pull probe from pot fitting.
9. Install new probe, making sure the probe extends out to the outer diameter of the heating elements on electric units. On gas units, the probe should extend to the outer edge of probe guard, making sure it doesn't extend out past guard.

CAUTION

Care must be taken not to extend the probe beyond the points described above, or damage to the probe could result. Also, make sure locking ferrule is in place and do not over-tighten nut or damage to probe could result. Snug nut up and tighten 1/4 turn past this point.

6-5. HIGH TEMPERATURE LIMIT CONTROL (ELECTRIC MODELS)

Description

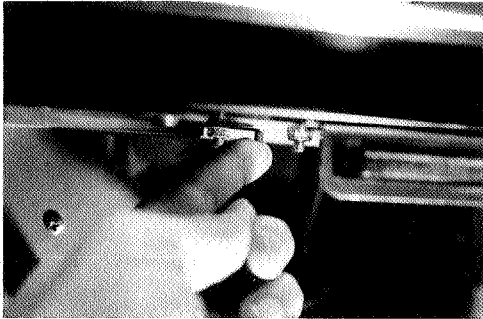

This high temperature control is a manual reset control which senses the temperature of the shortening. If the shortening temperature exceeds the safe operating limit, this control switch will open and shut off the heat to the frypot. When the temperature of the shortening drops to the safe operating limit, the control must manually be reset. Each frypot has a high temperature limit control.

Checkout

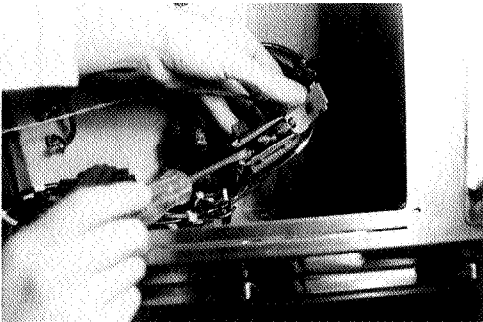

Before replacing a high temperature limit control, check to see that its circuit is closed.

NOTE

The shortening temperature must be below 380°F to accurately perform this check.

1. Remove electrical power supplied to the cookpot to be worked on.

WARNING

Place POWER switch to the OFF position, and unplug the power cord or open the wall circuit breaker. Be aware that the other controls will have power, or electrical shock could result.

2. Remove the control panel per section 6-3.
3. Remove control from bracket.
4. Remove the two electrical wires from the high temperature limit control.
5. Check for continuity between the two terminals after resetting the control. If the circuit is open, replace the control, then continue with this procedure. (If the circuit is closed, the high limit is not defective. Reconnect the two electrical wires.)

6-5. HIGH TEMPERATURE LIMIT CONTROL (ELECTRIC MODELS) (continued)

Replacement

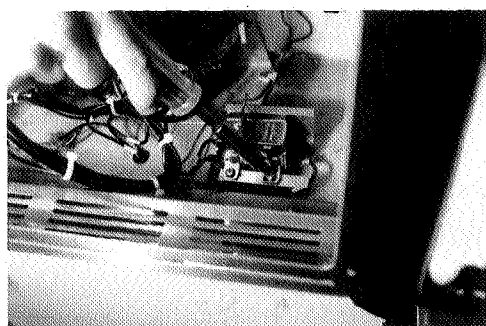
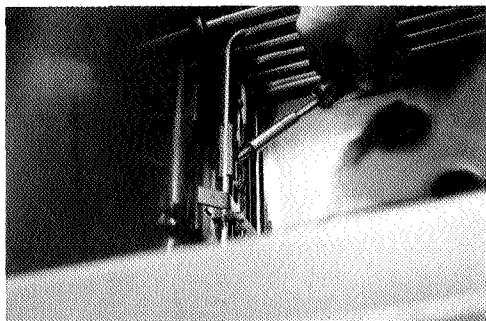
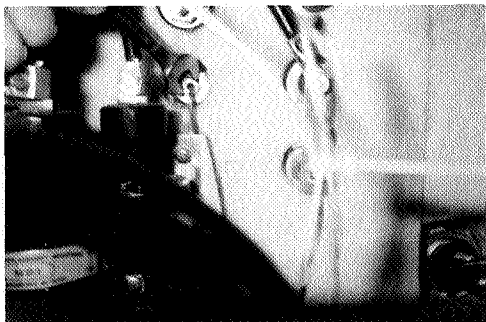

WARNING

Before following these steps, place POWER switch to the OFF position, and unplug the power cord or open the wall circuit breaker, or electrical shock could result. Be aware that the other controls will HAVE power.

1. If the tube is broken or cracked, the control will open, shutting off electrical power. The control cannot be reset.
2. Drain shortening from the frypot.
3. Remove control panel, per section 6-3.
4. Loosen small inside screw nut on capillary tube.
5. Remove capillary bulb from bulb holder inside the frypot.
6. Straighten the capillary tube.
7. Remove larger outside nut that threads into pot wall.
8. Remove the two screws that secures the high limit to the high limit bracket.
9. Loosen clamp on capillary tube.
10. Remove defective control from control panel area.
11. Insert new control and replace screws.
12. Uncoil capillary line, starting at capillary tube, and insert through frypot wall.

WARNING

To avoid electrical shock or other injury, the capillary line must run under and away from all electrical power wires and terminals. The tube must never be in such a position where it could accidentally touch the electrical power terminals.

13. Carefully bend the capillary bulb and tube toward bulb holder on heating elements.
14. Slip capillary bulb into bulb holder located on heating elements. Pull excess capillary line from pot and tighten nut into frypot wall.

6-5. HIGH TEMPERATURE
LIMIT CONTROL
(ELECTRIC MODELS)
(Continued)

CAUTION

Be sure capillary bulb of high limit is located behind front edge of elements. Capillary bulb and bulb holders should be positioned as not to interfere with basket or when cleaning the frypot wall, or damage to capillary tube could result.

- 15. With excess capillary line pulled out, tighten smaller nut.
- 16. Clamp capillary tube down to shroud.
- 17. Replace front panel.
- 18. Refill with shortening.

6-6. HIGH TEMPERATURE
LIMIT CONTROL
(GAS MODELS)

The gas units, OG-301/302/303, use the same high temperature limit control as the electric, OE-301/302/303, but the mounting of the capillary tube and fittings are different on the gas models compared to the electric models.

Checkout

Use the same procedure as in section 6-5.

Replacement

- 1. Place the power switch in the OFF position, and remove power supplied to the unit.

WARNING

Disconnect power supplied to the unit by unplugging the power cord, or turning off the wall circuit breaker or fuse. Electrical shock could result.

- 2. Drain shortening from frypot.
- 3. Remove control panel, per section 6-3.
- 4. Remove screws from heat shield and remove shield.

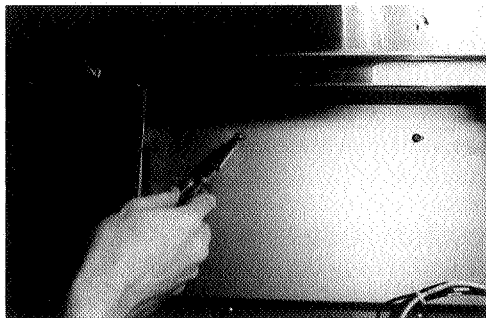

**6-6. HIGH TEMPERATURE
LIMIT CONTROL
(GAS MODELS)
(Continued)**

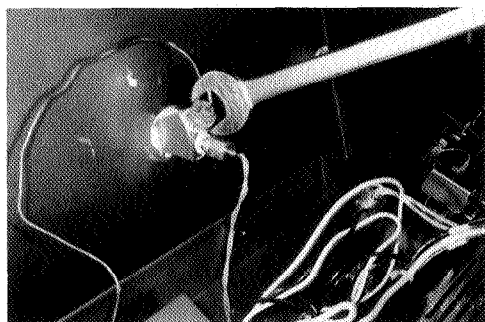
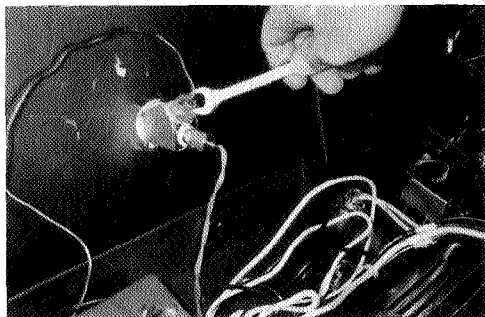

5. Remove probe as described in section 6-4.
6. Loosen small inside screw nut on capillary tube.
7. Remove capillary bulb from bulb holder on inside of frypot.
8. Remove larger outside screw nut that threads into "Y" fitting.
9. Cut the capillary bulb on the inside of cookpot, and remove the capillary from unit.
10. Remove capillary from clamp on shroud.
11. Remove the two screws that secures the high limit to bracket and remove the control from the unit.
12. Insert capillary of new high limit, through "Y" fitting.
13. Put pipe sealant on threads and screw "Y" fitting back into fitting in frypot.
14. Insert new control on bracket.
15. Carefully bend the capillary bulb towards the bulb holder and insert into holder.
16. Pull excess capillary line from pot and tighten nut into "Y" fitting.

CAUTION

Be sure capillary bulb of high limit is located close to frypot wall. Capillary bulb and line should be positioned as not to interfere with basket, or when cleaning the frypot wall, or damage to capillary tube could result.

17. With excess capillary line pulled out tighten smaller nut.
18. Clamp capillary tube down to shroud.

WARNING

To avoid electrical shock or other injury, the capillary tube must run under and away from all electrical power wires and terminals. The tube must never be in such a position where it could accidentally touch the electrical power terminals.

19. Replace probe, per section 6-4.
20. Replace front panel.
21. Refill with shortening.

**6-7. HEATING ELEMENTS
(ELECTRIC MODELS ONLY)**

NOTE

Heating elements are available for 208 and 230 voltage. Check data plate to determine the correct voltage.

Checkout

If the shortening's temperature recovery is very slow or at a slower rate than required, this may indicate defective heating element(s). An ohmmeter will quickly indicate if the elements are shorted or open.

1. Remove electrical power supplied to cookpot to be worked on.

WARNING

Place power switch in the OFF position and unplug the power cord or open the wall circuit breaker, for the cookpot to be worked on. Be aware the other controls will have power, or electrical shock could result.

2. Remove the control panel per section 6-3.
3. Perform an ohm check on one element at a time, with wires disconnected from element. If the resistance is not within tolerance, replace the element.

Voltage	Wattage	Resistance 10 Ohms (cold)
208	3750	11 ± 1.5
208	4500	9 ± 1
230	3750	12 ± 2
230	4500	11 ± 1.5

Replacement

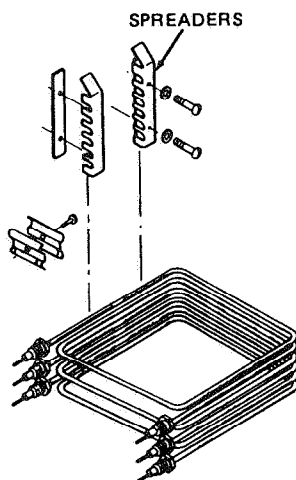

1. Drain the shortening.
2. Remove the High Limit bulb holder from the heating element inside the frypot.
3. Remove the heating element wires from the terminals by removing nuts (5) and washers (6 and 7). Label each so it can be replaced in the same position on the new element.
4. Loosen the bolts on the five element spreaders.
5. Slide the element spreaders to the center of the heating elements.
6. Remove the brass nuts (4) and washers (3), which secure the ends of the elements through the frypot wall.

6-7. HEATING ELEMENTS (ELECTRIC MODELS) (Continued)

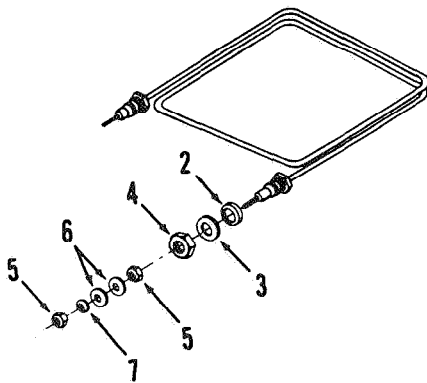

7. Remove the heating elements from the frypot as a group by lifting the far end and sliding them up and out toward the rear of the frypot.

NOTE

Always install new rubber O rings (2) when installing heater elements.

8. Install new heating elements with new rubber O rings (2) mounted on terminal ends, and spreaders loosely mounted in the center of the stacked elements.
9. Replace the heating elements, terminal end first at approximately 45° angle, slipping the terminal ends through the front wall of the frypot.
10. Replace the brass nuts (4) and washers (3) on the heating element terminals. Tighten the brass nuts to 30 foot lbs of torque.
11. Move the element spreaders from the center of the element, into a position which will spread each element apart evenly on all four sides, and tighten. Slide the fifth spreader over to protect the probe.
12. Replace the High Limit bulb holder on the top element, and position the bulb between the top and second element midway from side to side, and tighten screw which holds the bulb in place.
13. Reconnect the wires to the appropriate terminal as labeled when they were removed.
14. Replace the front control panel.
15. Connect the power cord to the wall receptacle or close wall circuit breaker.

CAUTION

Heating elements should never be energized without shortening in the frypot, or damage to elements could result.

16. Replace the shortening in the frypot.

6-8. HEATING CONTACTORS (ELECTRIC MODELS)

Description

Each electric fryer requires two switching contactors. One is the primary contactor and the second in line is the heat contactor. When open, the primary contactor allows no power to flow to the heat contactor. When closed, the primary contactor completes the timer circuit and the high limit (heat) circuit. It also supplies power to the heat contactor which is controlled by the thermostat.

Checkout (power removed)

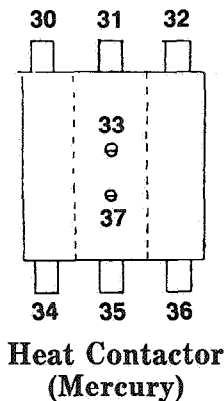
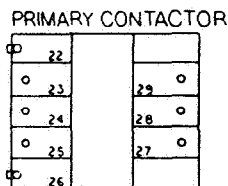

1. Remove electrical power supplied to the cookpot to be worked on.

WARNING

Place POWER switch to the OFF position, and unplug the power cord or open the wall circuit breaker, or electrical shock could result. Be aware that the other controls will have power.

2. Remove the control panel and insert it in the slot above the door. Refer to section 6-3.
3. Perform a check on the contactor as follows:

<u>Test Points</u>	<u>Results</u>
from 23 to 29	open circuit
from 24 to 28	open circuit
from 25 to 27	open circuit
from 30 to 34	open circuit
from 31 to 35	open circuit
from 32 to 36	open circuit
from 22 to 26	ohm reading 415
from 33 to 37	ohm reading 1500

NOTE

Wires should be removed and labeled to obtain an accurate check of contactors.

**6-8. HEATING CONTRACTORS
ELECTRIC MODEL
(Continued)**

Checkout (power supplied)

WARNING

The following checks are performed with the wall circuit breaker closed and the main power switch in the "ON" position. Extreme caution should be taken. Make connections before applying power, take reading, and remove power before removing meter leads, or electrical shock could result.

1. Re-apply power to unit and turn power switch "ON."
2. Using illustrations from previous page, check voltage as follows:

<u>Test Points</u>	<u>Results</u>
<u>Heat Contactor</u>	
from terminal 34 to 35	The voltage should read the same at each terminal.
from terminal 35 to 36	
from terminal 34 to 36	
<u>Primary Contactor</u>	
from terminal 27 to 28	It should correspond to the voltage rating stated on the data plate
from terminal 28 to 29	
from terminal 27 to 29	

Replacement

Primary Contactor

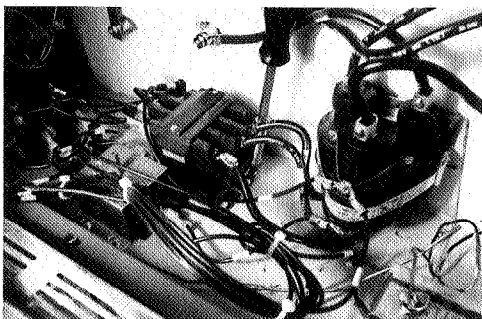
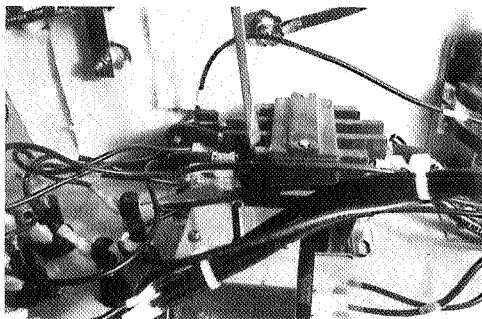

If either contactor is defective it must be replaced as follows:

WARNING

Remove electrical power supplied to the cookpot to be worked on, by unplugging or opening the wall circuit breaker, or electrical shock could result. Be aware that the other controls will have power.

1. Remove only those wires directly connected to the contactor being replaced. Label the wires.
2. Remove the two mounting screws on the base plate and remove contactor.
3. Install the new contactor and tighten the two mounting screws.

6-8. HEATING CONTRACTORS

Heat Contractor

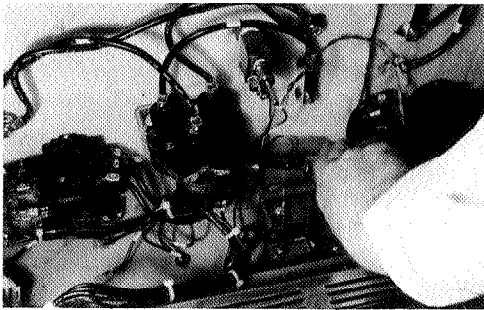
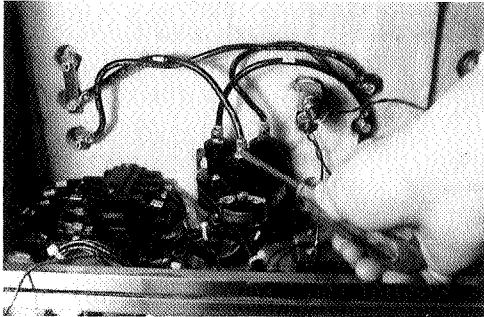

4. Connect the labeled wires to their respective positions.
5. Install the control panel per section 6-3.
6. Reconnect power to the fryer and test the fryer for proper operation.

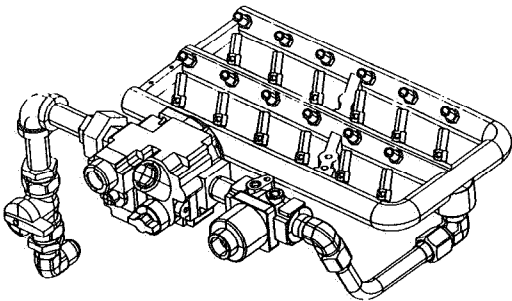
6-9. GAS BURNER ASSEMBLY
(GAS MODELS)

The gas model fryers have gas burner assemblies per cookpot consisting of Burner Casting, Orifices, Thermocouples, Pilot Holders, Main Gas Valve Controls, and Gas Safety Solenoid.

Also, each burner has a main gas shut-off valve, so all burners do not have to be shut down to work on one burner assembly.



If converting from natural gas to propane or from propane to natural gas, conversion must be done by a qualified service technician.

To avoid personal injury or property damage, before starting this procedure, move the power switch to the "OFF" position, and unplug power cord from wall receptacle. Turn off the gas supply to the frypot to be worked on, or a possible explosion could result.

**6-9. GAS BURNER ASSEMBLY
(GAS MODELS)
(Continued)**

**Removal
and
Installation**

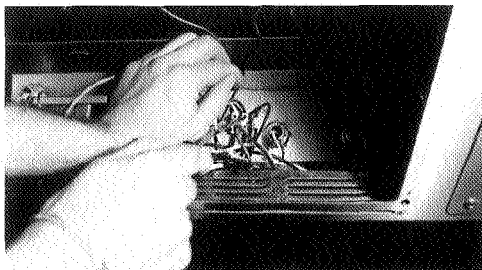
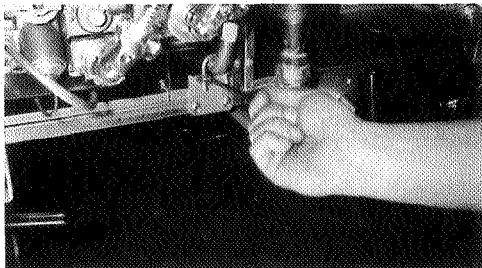
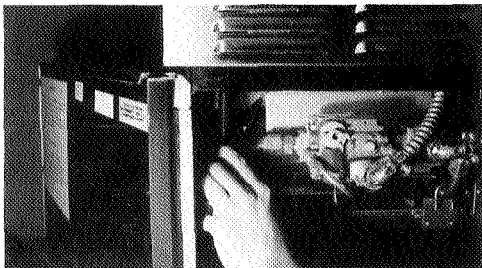
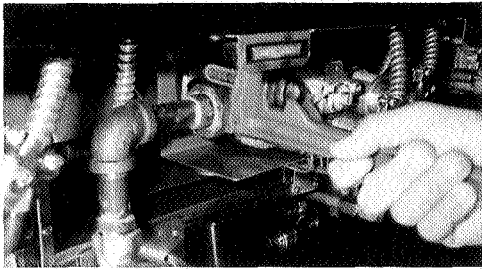
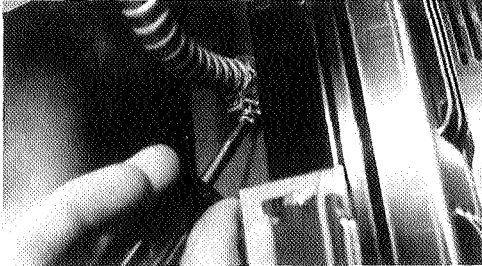

1. Remove the control panel per section 6-3.
2. Open doors to bottom of unit.
3. Remove the flexible conduit from the heat shield and shroud which contains the wires of the gas valve and solenoid.
4. Disconnect gas supply line from connector at gas valve.
5. Loosen the two screws on the Heat Shield Deflector on the firebox and flue assembly and raise deflector to its highest position. Retighten screws to hold at this position.
6. Remove U-bolt from bracket.
7. Remove and label wires from terminal block behind panel.
8. Remove two screws from gas valve heat shield.
9. Remove entire gas burner assembly, by lifting and pulling toward front of fryer.
 - a. Replace thermocouple as required per section 6-10.
 - b. Repair or replace gas valve as required per section 6-11.
 - c. Replace orifices as required.

NOTE

There are 23 brass and 1 stainless steel orifice. The stainless steel orifice is to be mounted adjacent to the pilot light.

10. Make other repairs or replacements as required.
11. Install entire gas burner assembly, reverse of above steps.
12. Turn on the gas supply to that frypot.



Check for leaks per section 2-7. Leaking gas may cause an explosion.

13. Connect the power cord to the wall receptacle.
14. Relight the gas pilot per the instructions in section 2-9.

**6-10. THERMOCOUPLE
(GAS MODELS)**

Description

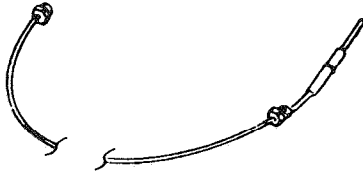

The thermocouple controls the gas valve. It generates voltage in the millivolt. This voltage signals the gas control valve to remain open to the pilot and burner. When the voltage is not generated the gas valve will shut off, not allowing gas to the pilot and main burner.

Safety Precautions



If converting from natural gas to propane gas or from propane gas to natural gas, conversion must be done by a qualified technician.

To avoid injury or property damage, before starting this procedure, move the MAIN POWER switch to the OFF position. Disconnect the main circuit breaker at the circuit breaker box or unplug the service cord at the wall receptacle. Turn off the main gas supply to the frypot to be worked on, or possible explosion could result.

**Replacement of
Thermocouple**

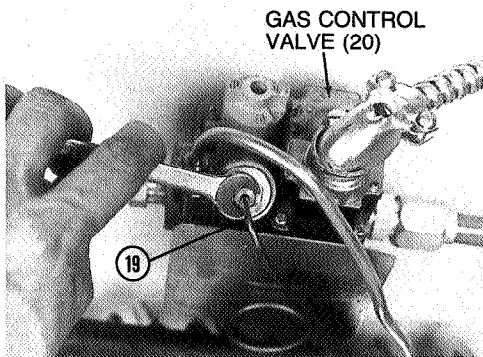

Step 1

Removal of the THERMOCOUPLE is accomplished with the main gas supply shut off. The main burner may remain inside the fryer, but the work is more easily performed with the burner removed.

1. Remove the nut securing the thermocouple (19) in the gas control valve (20).
2. Remove the nut securing the thermocouple in the pilot holder.
3. Install the new thermocouple, being careful not to create sharp bends in the tubing. When the pilot is lit, the flame must surround the top of the thermocouple.
4. Turn on the main gas supply and reconnect the electrical power.
5. Light the pilot per paragraph 2-11 and test the fryer for proper operation.

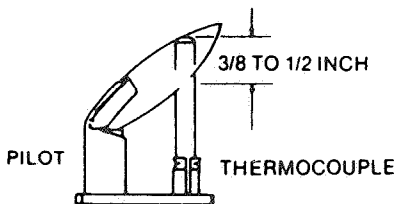

Step 3

6-11. GAS CONTROL VALVE

Description

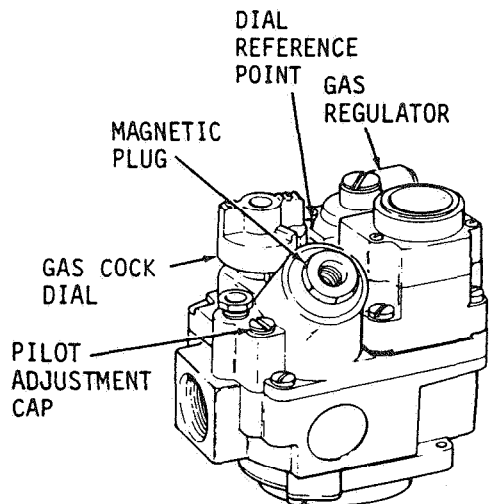

Safety Precautions

Operator Replacement

The gas control valve regulates the flow of gas to the pilot and the main burner. The valve consists of: gas regulator, magnetic plug, pilot gas tube, gas cock dial, pilot adjustment cap and screw, gas outlet and inlet ports, thermocouple connector, and electrical connection. The gas valve also has a dial reference point. - OFF/PILOT/ON.

The components of the gas valve can be serviced without removing the complete valve from the fryer.



If converting from natural gas to propane gas or from propane gas to natural gas, conversion must be done by a qualified technician.

To avoid injury or property damage, before starting this procedure, move the MAIN POWER switch to the OFF position. Disconnect the main circuit breaker at the circuit breaker box or unplug the service cord at the wall receptacle. Turn off the main gas supply to the frypot to be worked on, or possible explosion could result.

If the gas control valve must be replaced, remove per paragraph 6-9.

1. Depress the gas cock dial and turn to the OFF position.
2. Remove control panel per section 6-3.
3. Label and remove the gas valve wires from terminal block.

6-11. GAS CONTROL VALVE (Continued)

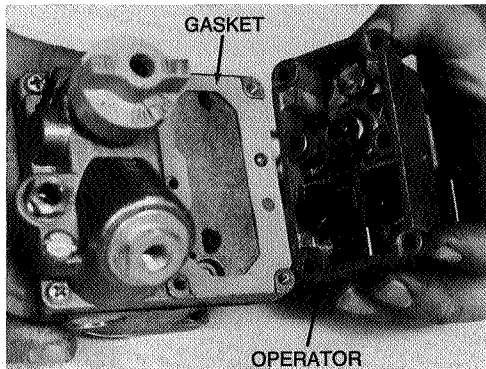

Step 5

4. Remove the 90° connector and conduit from the old gas valve and install on the replacement gas valve.
5. Remove the four screws securing the operator and gasket.
6. Secure the new operator and gasket with the four screws provided.
7. Reconnect the gas valve wires.
8. Install the control panel per paragraph 5-4.

NOTE

Check Procedure

120 volt - 50/60 Hz - 235-ohms
 208-240 volt - 50/60 Hz - 880-ohms

Regulator Replacement

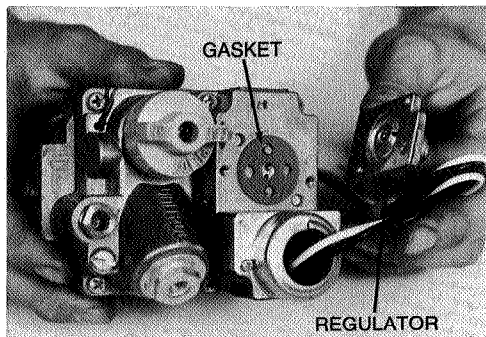

Step 1

1. Remove the two screws securing regulator to the operator.
2. Replace with the new gasket and regulator and secure with the two screws supplied.

Magnetic Plug Replacement

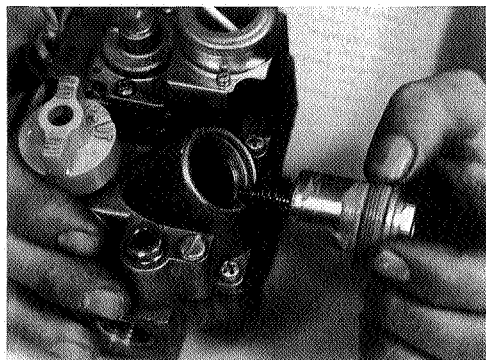

Step 2

1. Remove by unscrewing the hexagon shaped plug, with a 5/8 inch socket wrench.
2. Install the new magnetic plug by applying a small amount of thread lubricant and tighten the plug to prevent a gas leak.

6-11. GAS CONTROL VALVE (Continued)

Adjusting Pilot Burner

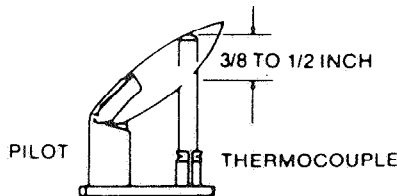

Adjusting Regulator

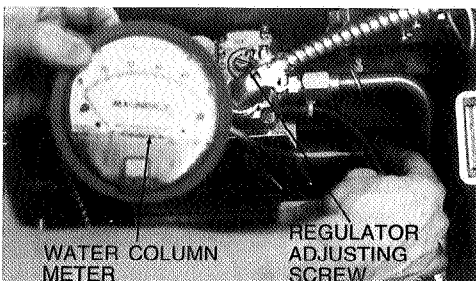
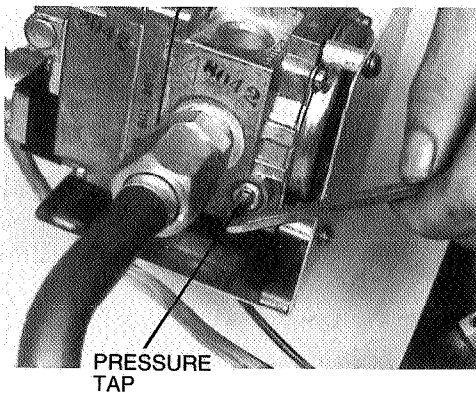

Step 1a

NOTE

The following two procedures must be performed with the gas supply reconnected and turned on. The service cord must be plugged into the receptacle and the circuit breaker on.

1. The pilot burner is preset at the factory. It may require resetting at the time of installation.
 - a. Remove the pilot adjustment cap.
 - b. Use a small flat screwdriver and rotate the adjustment screw counterclockwise to increase the size of the flame. Rotate clockwise the adjustment screw to decrease the size of the flame.

NOTE

The flame should be set high enough to surround the top of the thermocouple.

1. The pressure regulator is preset at the factory. It may require resetting at the time of installation.
 - a. Turn gas cock dial to OFF position.
 - b. Attach a manometer to the gas valve at the "Pressure Tap."
 - c. Turn gas cock dial to "PILOT," light, and turn to ON.
 - d. Remove the regulator adjustment screw cap.
 - e. Rotate the adjustment screw counterclockwise to increase the column indicated on the manometer or rotate clockwise to lower the column indicated.
 - f. Turn gas cock dial to OFF and remove manometer.
 - g. Replace the regulator adjustment screw cap.
 - h. Turn gas cock dial to PILOT and relight. Leak test with soap and water solution.

NOTE

Natural gas regulator is factory preset at 3½ inches water column.

Propane gas regulator is factory preset at 10.0 inches water column.

6-12. FUSES AND FUSE HOLDERS

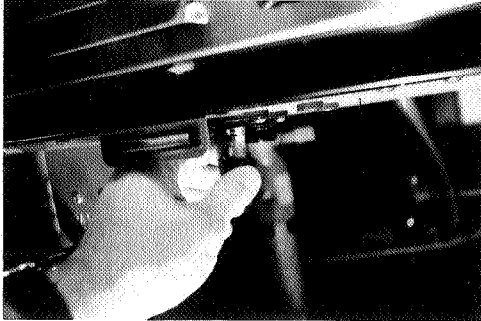

Checkout

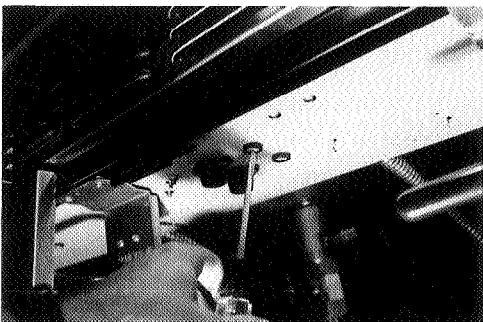
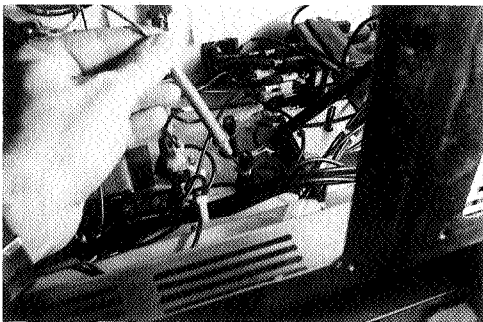

The electric fryers have two 15 amp fuses to protect the circuitry, and two 15 amp fuse to protect the PC board, for each control panel, found behind doors, up under shroud. The gas units do not have fuses other than at the main power source.

NOTE

Each PC board has a 1.5 amp fuse as a surge protector. If the power comes on, but no display, check this fuse.

WARNING

Before starting this procedure, move the power switch to the OFF position and unplug the power cord at the wall receptacle, for the panel to be worked on. Be aware the other controls will have power, or electrical shock could result.

1. Remove control panel per section 6-3.
2. Remove wires to fuse holders.
3. Using a continuity light, or volt meter, the circuit should be closed across terminals. If open, replace fuse.

6-13. DRAIN SWITCH

All model fryers have a drain microswitch in line with the gas valve or heat contactor. When the drain valve is opened to drain the shortening, this causes the drain switch to open, shutting down the gas to the burners or electrical power to elements.

WARNING

Disconnect power supplied to the unit by unplugging the power cord, or turning off the wall circuit breaker or fuse. Be aware that the other controls will have power on electric models, or electrical shock could result.

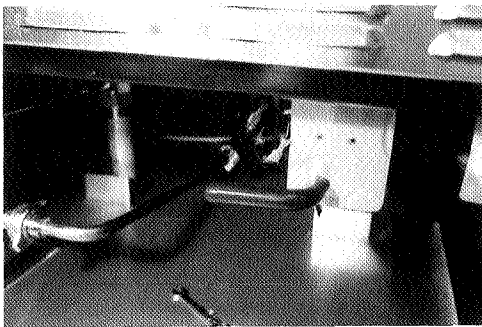
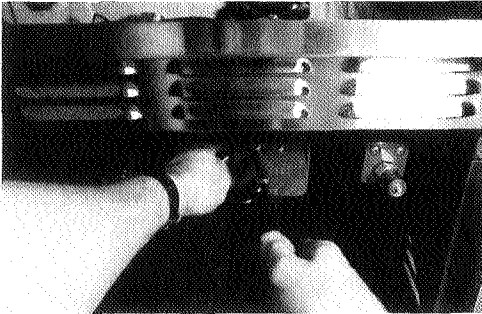
Checkout

1. Remove the two screws and nuts securing the switch and switch cover.
2. Label and disconnect wires to microswitch.
3. Check for continuity on the two outside terminals. With plunger extended, the circuit should be closed, when the plunger is pushed down, the circuit should be open.

Replacement

4. To replace drain switch, attach wires to new switch.
5. Position plunger and attach drain switch & switch cover with the nuts and screws.
6. Test to see if valve extension rod actuates the switch.

NOTE

Listen for a click while rotating drain valve extension rod.

6-14. POWER ON/OFF SWITCH

Checkout

The Power Switch is a two way rocker switch. With the switch in the "ON" position, this energizes the controls.

1. Remove power supplied to the unit, or on electric models, to the cookpot to be worked on.

WARNING

Disconnect power supplied to the unit by unplugging the power cord, or turning off the wall circuit breaker or fuse. Be aware that the other controls will have power on electric models, or electrical shock could result.

2. Remove appropriate control panel, but leave hinged on unit.
3. Remove and label wires from the switch and check across top and bottom terminals for continuity. With the switch in the "ON" position, the circuit should be closed. If the switch is defective, replace it by following the next steps.

Replacement

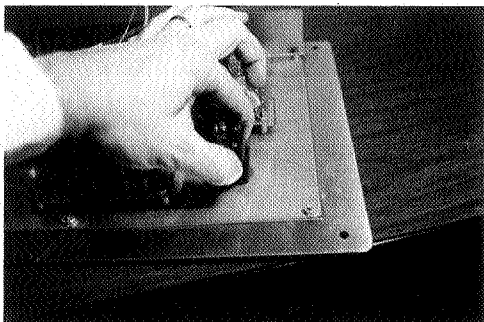

4. Push in on tabs on the ends of the switch and pull switch from the front of the control panel.
5. Replace new switch, replace wires, and replace control panel.
6. Reapply power to unit.

6-15. FILTER SWITCH

Checkout

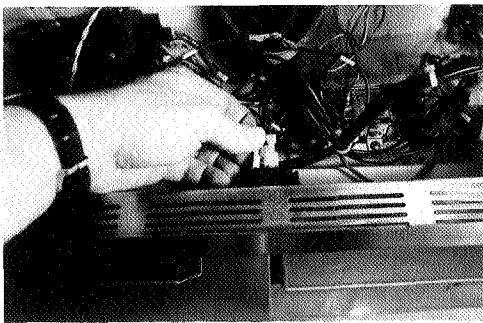

Replacements

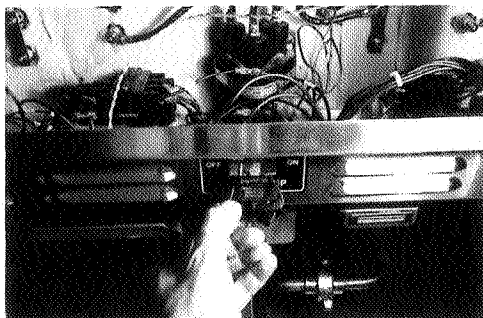
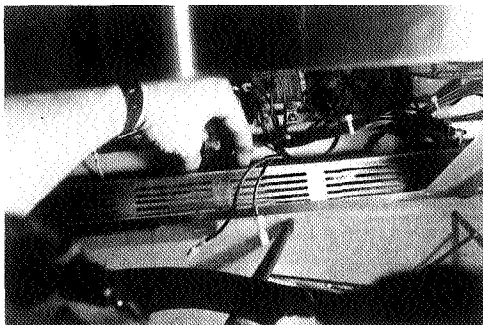

The filter switch is a two way rocker switch with the switch in the "ON" position, the filter motor energizes to pump up the shortening from the drain pan.

1. Remove power supplied to the unit, or on electric models, to the far right cookpot that powers the filter switch.

WARNING

Disconnect power supplied to the unit by unplugging the power cord, or turning off the wall circuit breaker or fuse. Be aware that the other control will have power on electric models, or electrical shock could result.

2. Remove the middle control panel per section 6-3.
3. Remove and label wires from the switch and check across top and bottom terminals for continuity. With the switch in the "ON" position, the circuit should be closed. If the switch is defective, replace it by following the next steps.

4. Push in tabs on the ends of the switch and pull switch from the front of the control panel.
5. Replace new switch, replace wires, and install panel.
6. Re-apply power to unit.

6-16. FILTERING SYSTEM

Filter Pump Repair
Description

The filtering system consists of the motor and filter pump assembly, filter screen assembly, and tubing.

The two most common causes for a fryer's inability to pump shortening is that the pump is clogged with breadding or solid shortening has cooled and solidified in the lines and pump.

WARNING

Before starting this procedure move MAIN POWER SWITCH to OFF position. Disconnect main circuit breaker at the circuit breaker box and unplug service cord from wall receptacle, or electrical shock could result.

Cover Removal

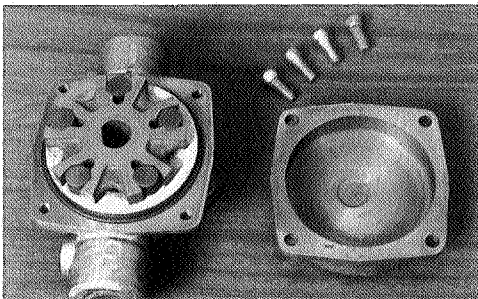
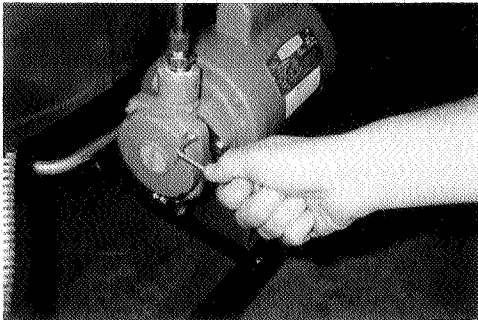

Step 2

1. Loosen the four allen head screws on the end of pump and remove the cover.
2. The inside is now exposed leaving a rotor and five teflon rollers. Clean the rotor and rollers.
3. To reassemble, place rotor on drive shaft, and place roller into rotor.

NOTE

A small amount of shortening might be needed to hold the bottom roller into place until cover plate is put on. Make sure O-ring is in proper position on plate.

6-16. FILTERING SYSTEM (Continued)

Pump Removal

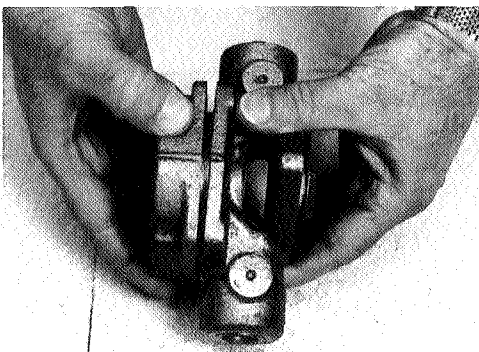
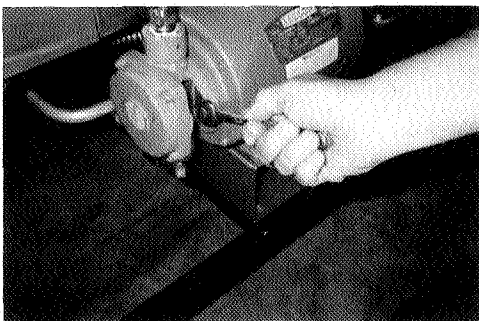
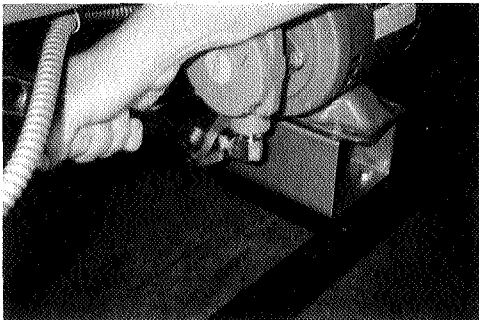
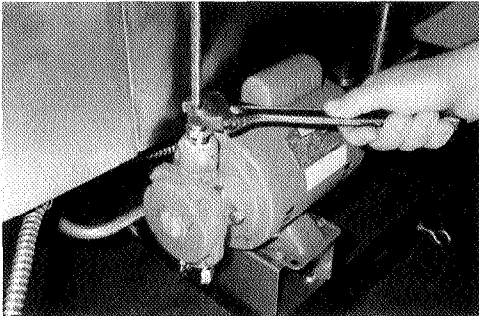

CAUTION

1. If the pump needs to be replaced, loosen one inch nuts from the outflow and inflow lines. Then remove the two bolts holding the pump to the motor with a 1/2 inch wrench.

2. The shaft seal should remain on the motor shaft, or if leaking, could be replaced at this time.

3. To replace the pump, remove the four allen screws, front plate, rotor, and rollers from pump. Place the pump onto the shaft and against the shaft seal. Place the two 1/2 inch bolts through the pump and into the motor and tighten. Then replace the rotor, rollers, front plate and tighten the allen screws.

CAUTION

When removing a pump from a motor note the positions of the INLET and OUTLET parts. Installation of the pump on the motor in any other position could cause damage to the fryer. There is an indicator on the side of the two halves of the pump, this mark must be together and face to the front of the fryer.

**6-16. FILTERING SYSTEM
(Continued)**

**Pump Removal
(Continued)**

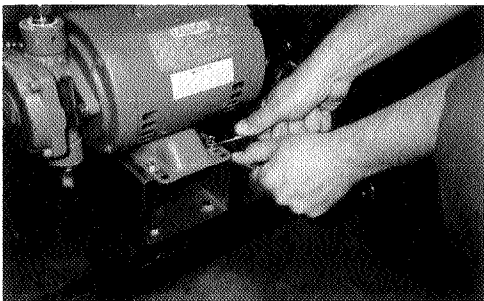
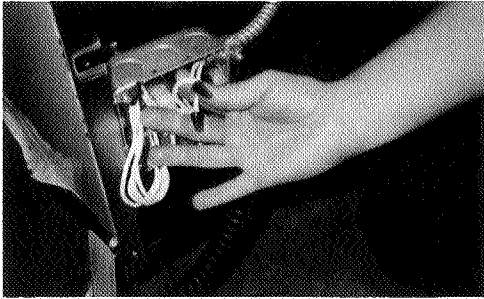

**Filter Pump Motor
Protector - "Manual Reset"**

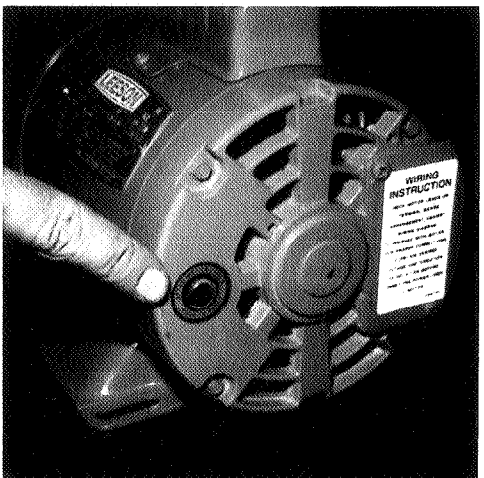

4. To replace the pump and motor assembly, insure the main power has been removed from the fryer.

WARNING

Before starting this procedure move MAIN POWER SWITCH to OFF position. Disconnect main circuit breaker at the main circuit breaker box and unplug service cord from wall receptacle, or electrical shock could result.

5. Remove the cover from the junction box and remove the wire nuts attaching wires leading into the flexible conduit going to the motor.
6. Loosen the two screws securing the flexible conduit to the conduit connector.
7. Remove tubing to the pump.
8. Remove hardware attaching the motor to the motor base bracket and remove motor and pump assembly.

The filter pump motor is equipped with a manual reset button in the event the motor's thermal protector actuates. This reset button is located on the rear of the motor. Wait approximately 5 minutes before attempting to reset this protector device.

WARNING

To prevent burns caused by splashing shortening, the unit's main power switch must be in the OFF position before resetting the filter pump motor's manual reset protection device.

6-17. GAS CONVERSION

Introduction

Gas model fryers are factory available for either NATURAL GAS or PROPANE GAS. Factory conversion kits for natural gas and propane gas are available that require the burner jets, pilot jet and regulator assembly to be changed.



Conversion must be accomplished by an authorized Henny Penny dealer or service representative, or personal injury could result.

Service Hints

On NATURAL GAS installation, the gas pressure regulator on the automatic gas control valve is factory set at 3.5 inch water column.

On PROPANE GAS installations, the gas pressure regulator on the automatic gas control valve is factory set at 10.0 inch water column.

After converting the fryer, turn on the gas supply and check for leaks. A simple method is to brush all the connections with soapy water, and watch for bubbles which indicate escaping gas.



Never use an open flame to test for leaks. Escaping gas could cause an explosion, and personal injury or property damage could result.

**6-17. GAS CONVERSION
(Continued)****Maintenance****WARNING**

Before starting this procedure move MAIN POWER SWITCH to OFF position. Disconnect main circuit breaker at the main circuit breaker box and unplug service cord from wall receptacle, or electrical shock could result.

To convert from one type of gas to another the following procedure may be followed:

1. Turn the gas cock dial to the OFF position.
2. Close the main gas valve and disconnect fryer supply line.
3. Remove gas control valve and burner assembly per section 6-9.
4. Remove the burner orifices (24 each), and replace with orifices in gas conversion kit 16247 - natural to propane conversion or kit 16248 - propane to natural conversion kit.
5. Remove the pilot orifice and replace with the one from the kit being installed.
6. Remove the two screws securing the gas valve regulator, and remove regulator and diaphragm, and replace with each from the kit being installed, per section 6-11.
7. Install converted gas control valve and burner assembly per section 6-9.
8. Connect the gas supply to the fryer.
9. Be sure the power switch is in the OFF position, gas control valve in the OFF position.
10. Connect the electrical power to the fryer.
11. Check for gas leak at supply line as per service hints in this section.
12. Turn the main gas valve on and turn the gas control valve to the pilot position.

6-17. GAS CONVERSION (Continued)

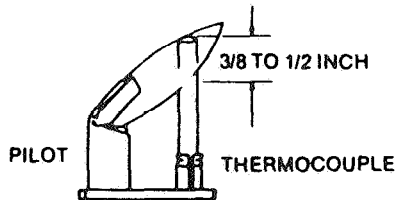

6-18. GAS SAFETY SOLENOID (GAS MODELS ONLY)

Replacement

13. Check for gas leak at the gas control valve and main gas valve per step 11 of this section. If there are no leaks, continue to step 14.



If a leak is detected, shut off gas valves and repair leak. Escaping gas could cause an explosion, and personal injury and property damage could result.

14. With the gas cock dial at PILOT, depress the dial and light the pilot burner per section 6-11.

The Gas Safety Solenoid is a gas line shut off, to the burner, if the high limit trips. When the high limit is reset, the solenoid should open.

If the high limit is closed, the pilot lit, and the gas valve checks out, the gas solenoid needs replaced.

NOTE

A "click" may be heard if solenoid is working properly.

1. Remove power supplied to the unit.

WARNING

Disconnect power supplied to the unit by unplugging the power cord, or turning off the wall circuit breaker or fuse, or electrical shock could result.

2. Turn the gas shut off to the off position (see operations section).
3. Open door to bottom of unit.
4. Remove control panel per section 6-3.
5. Remove gas burner assembly per section 6-9.
6. Remove solenoid from burner assembly.
7. Reinstall burner assembly per section 6-9.

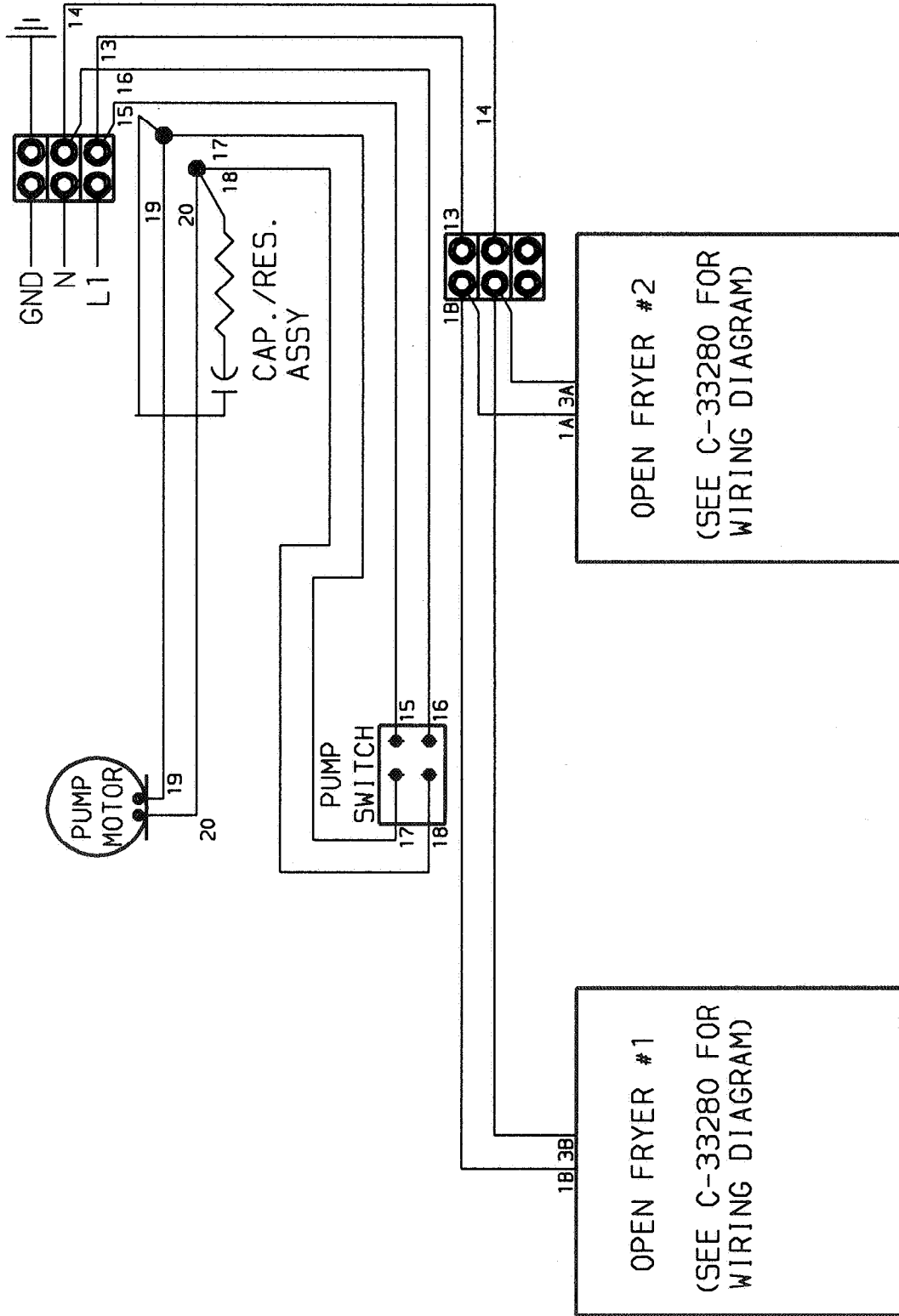

MODEL OG-302 SYSTEM
120V 50/60HZ 1PH

33461

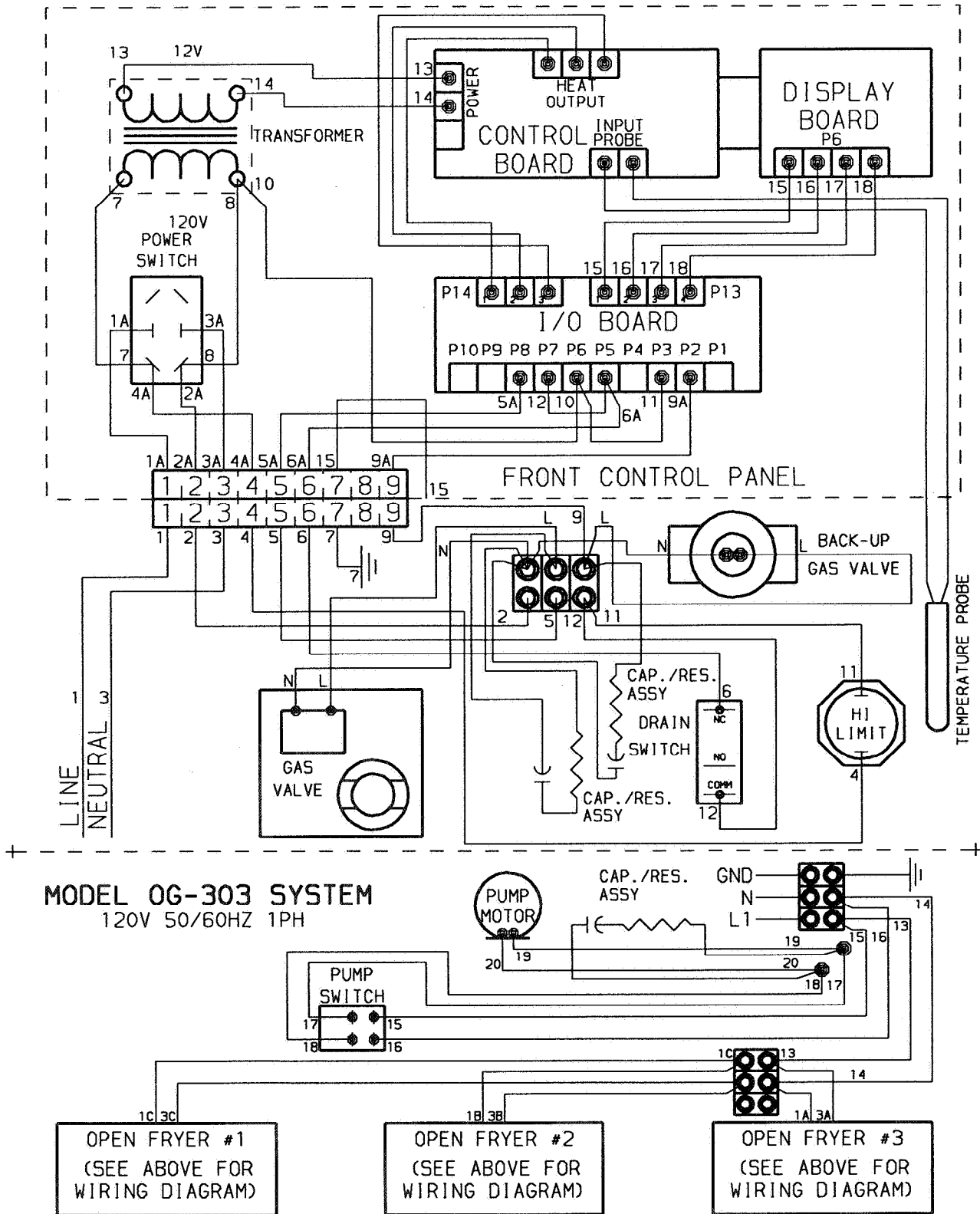

33375

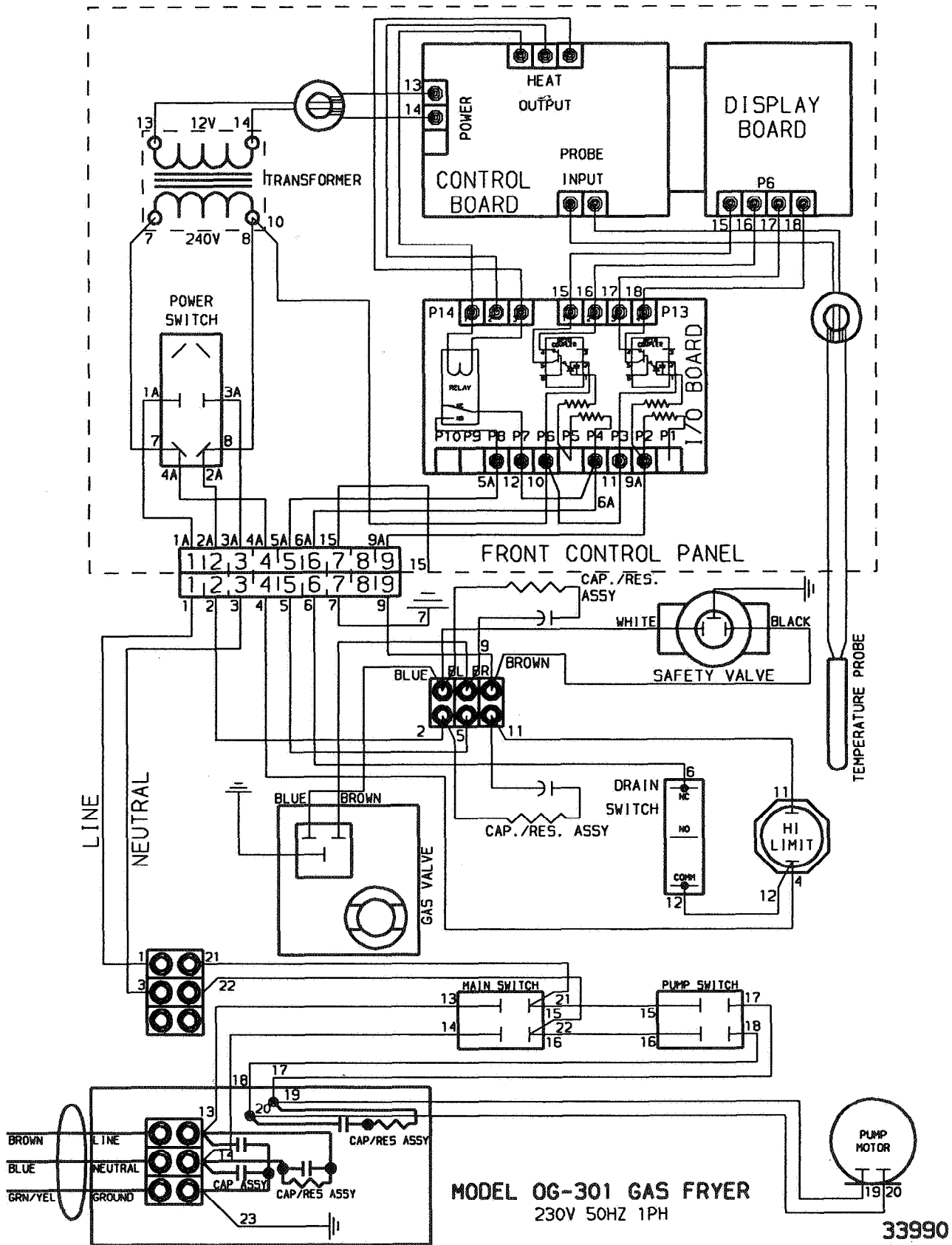

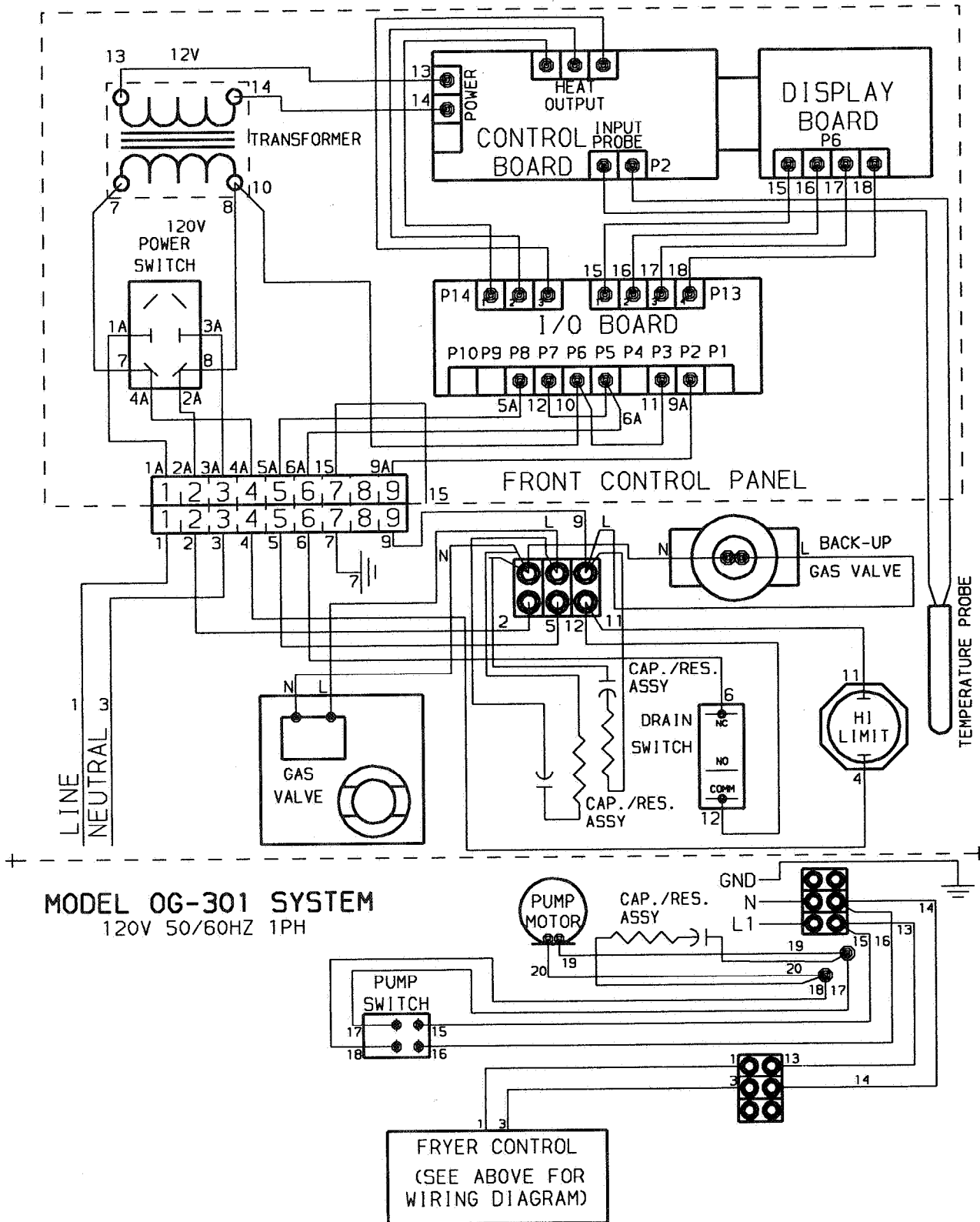

33724

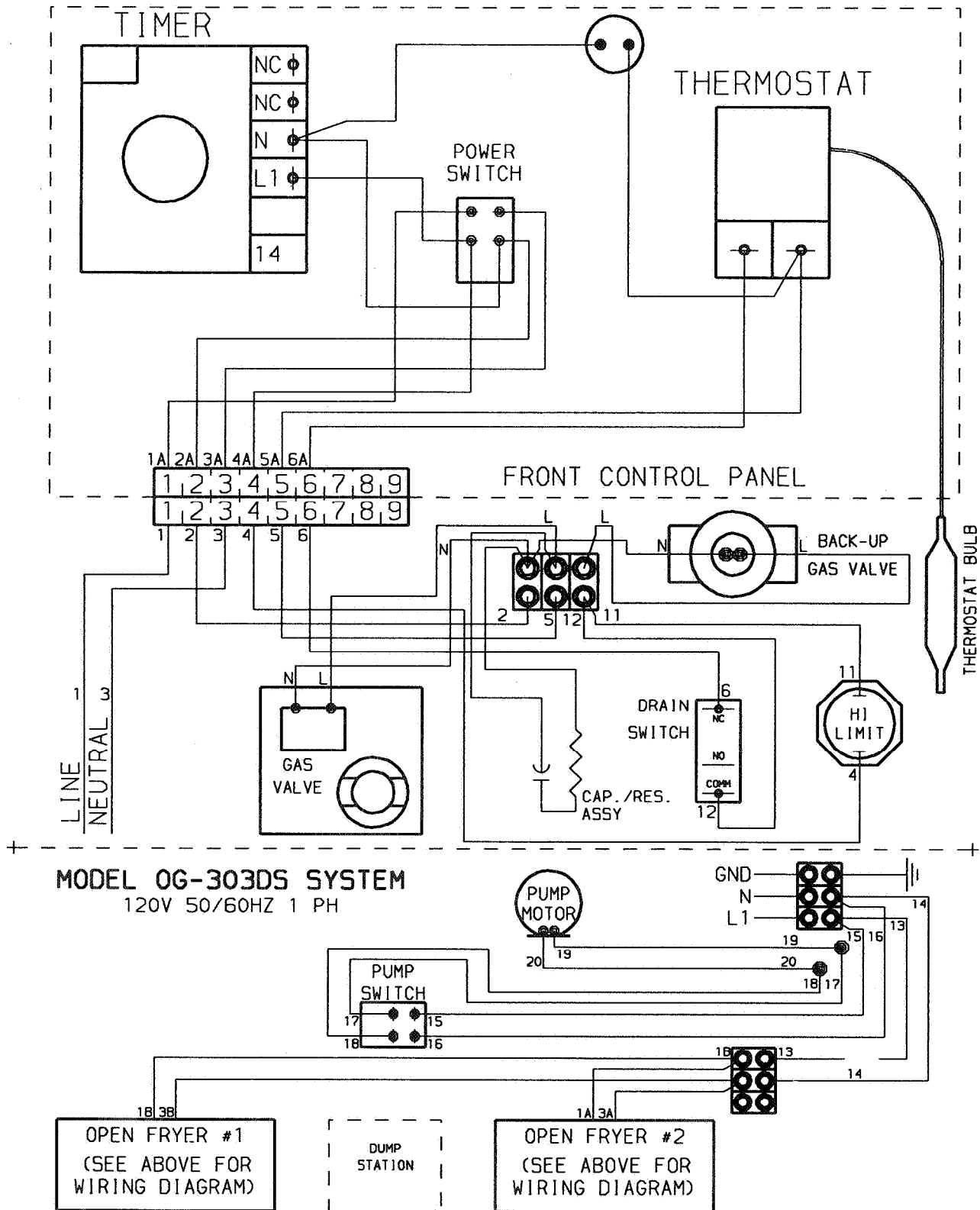

54002

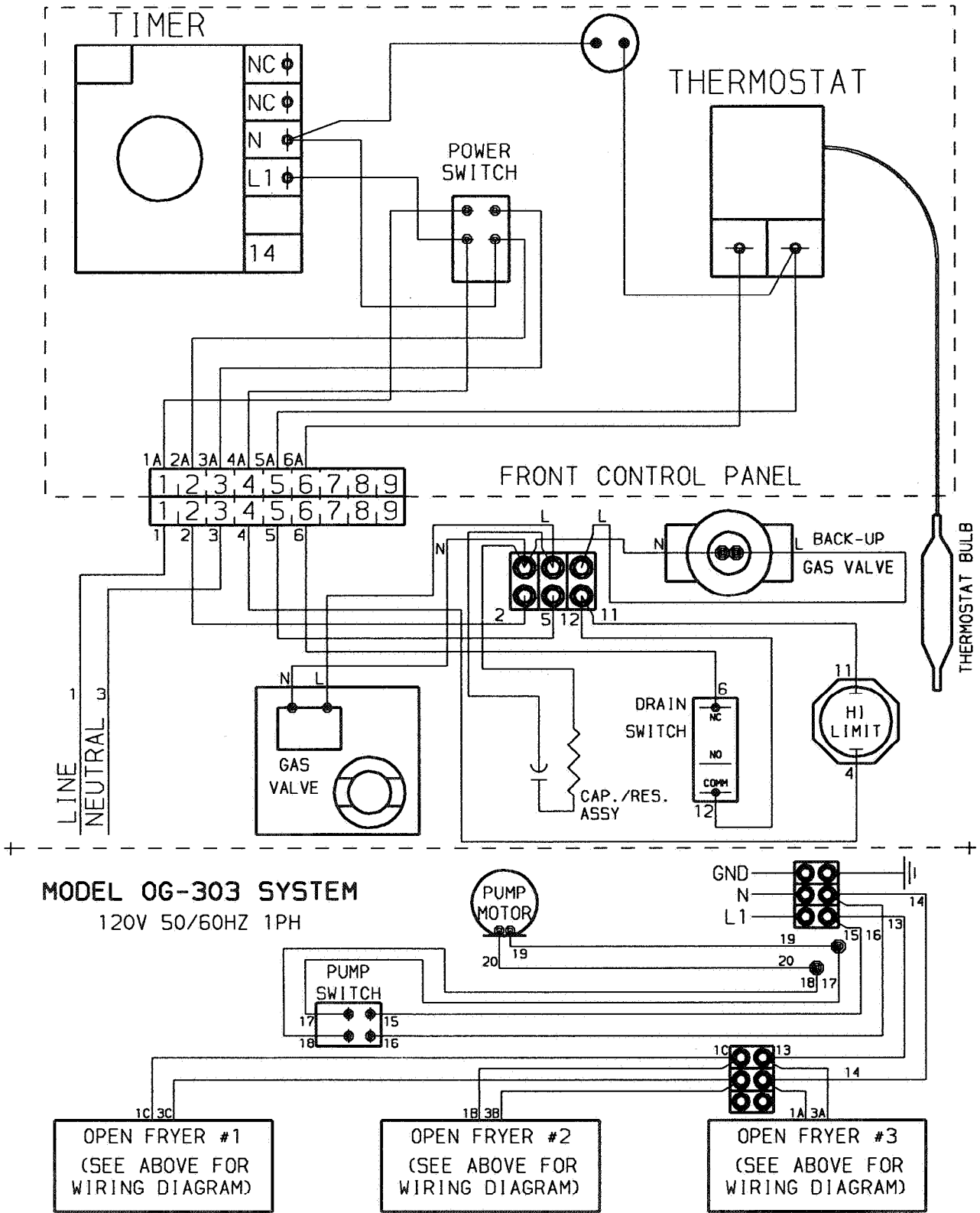

45382

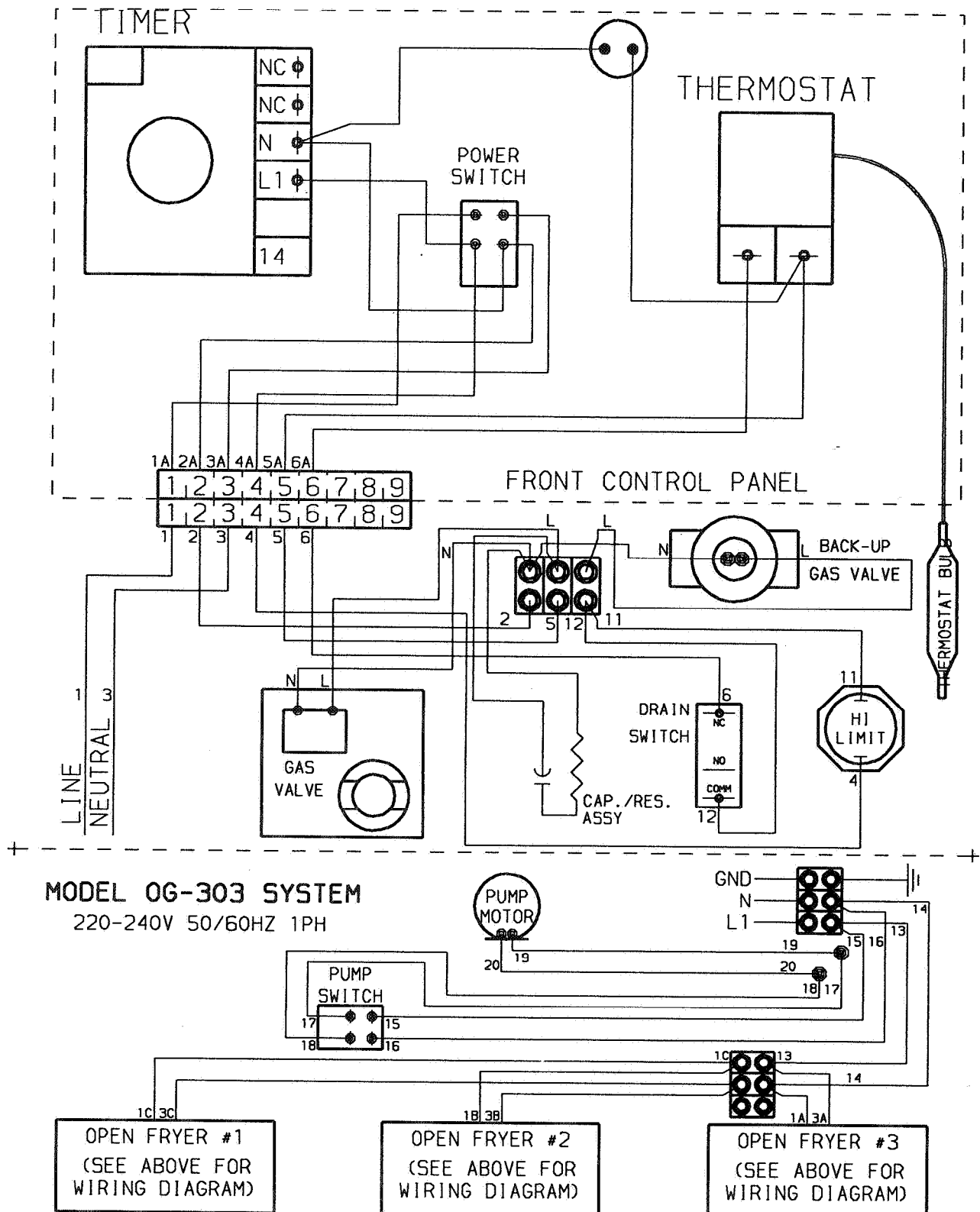

45389

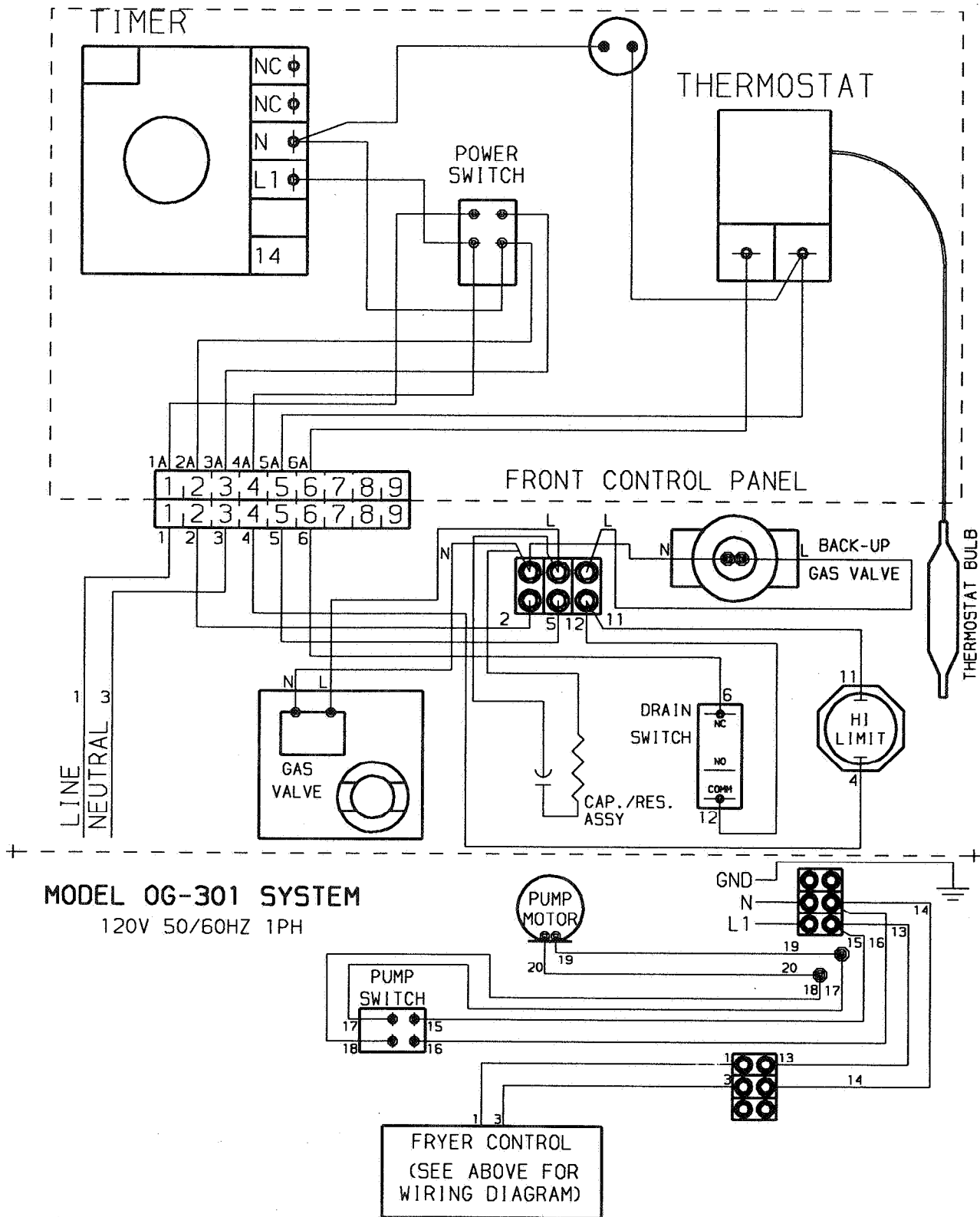

45392

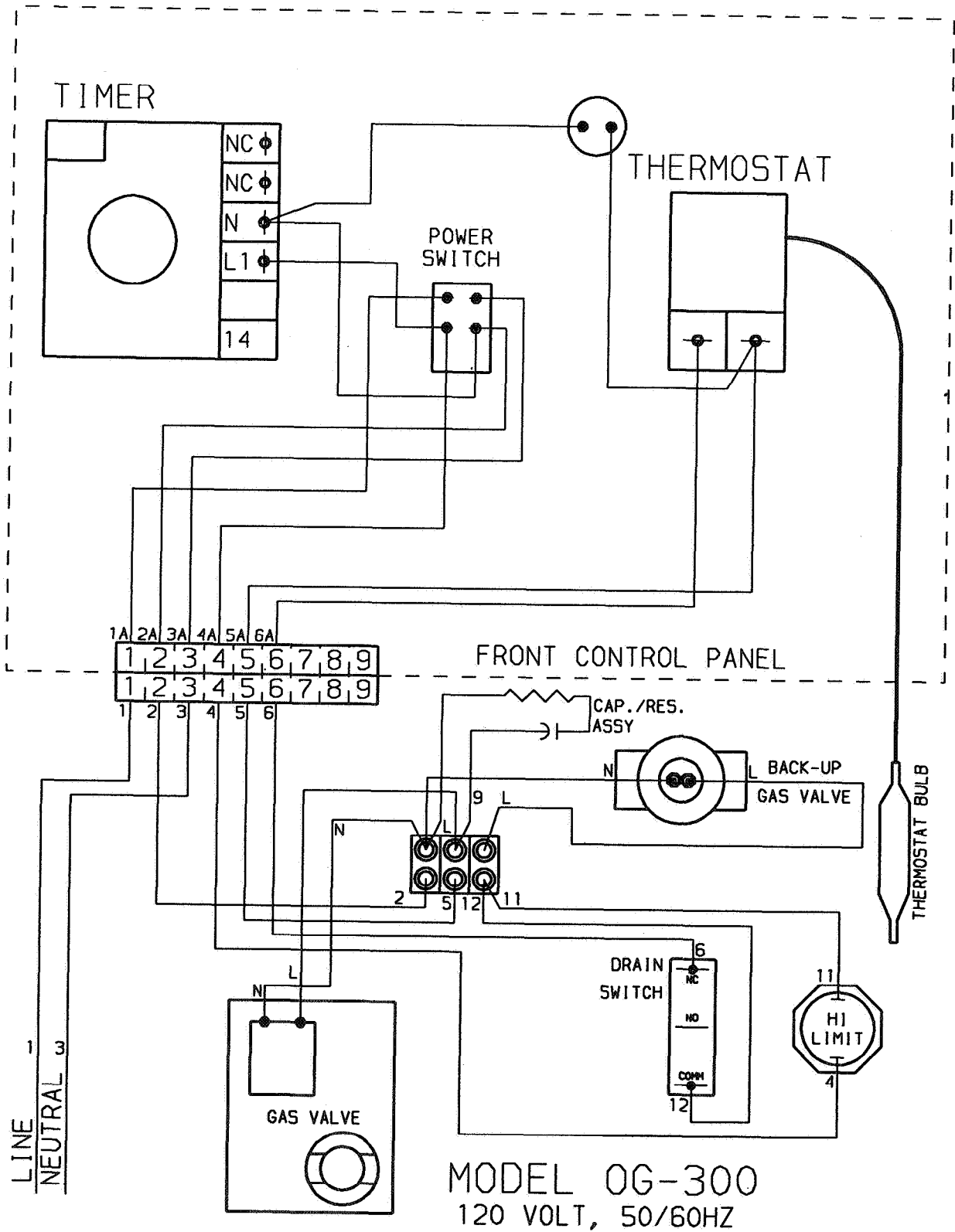

45325

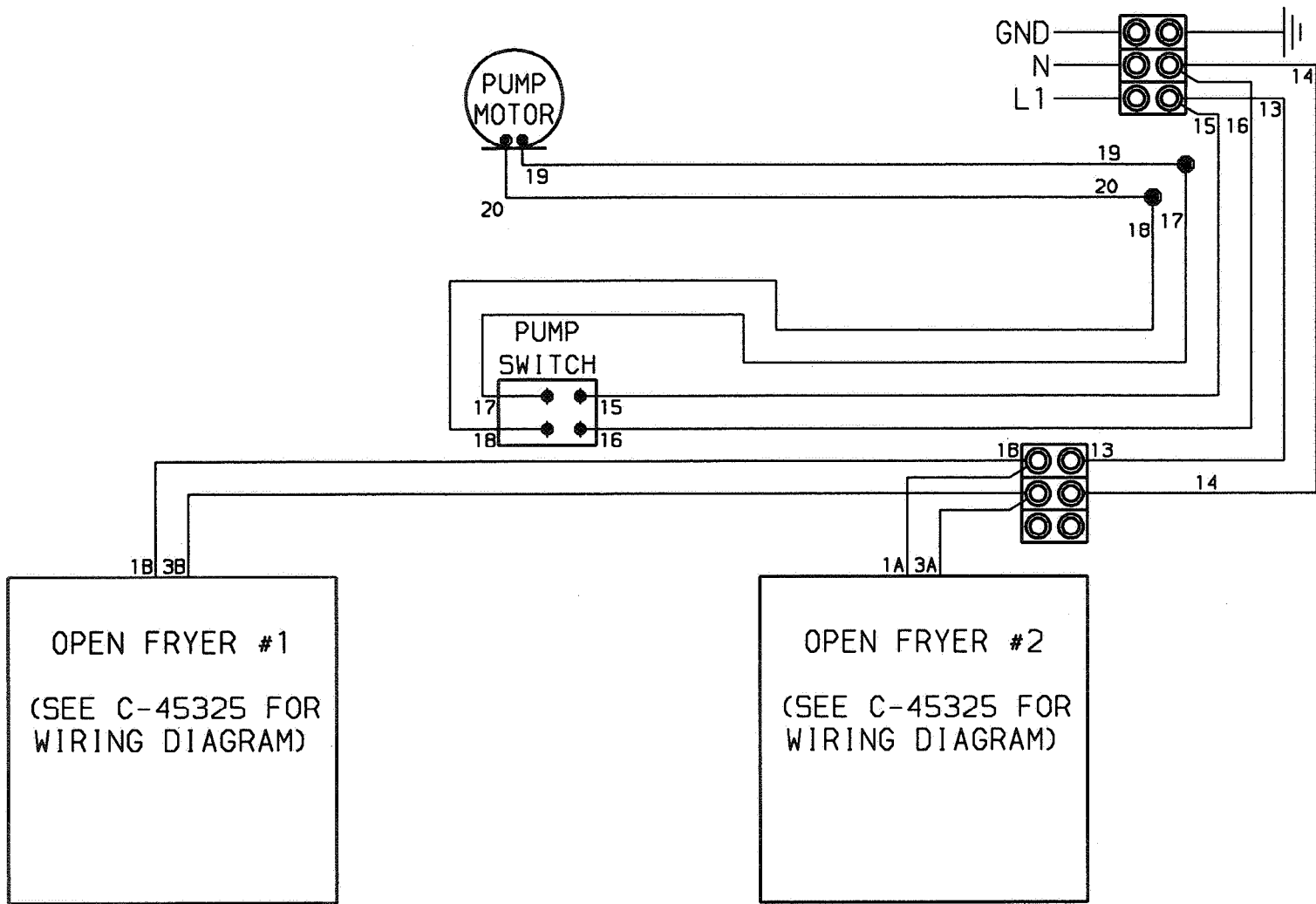

MODEL OG-302 SYSTEM
120V 50/60HZ 1PH

45390

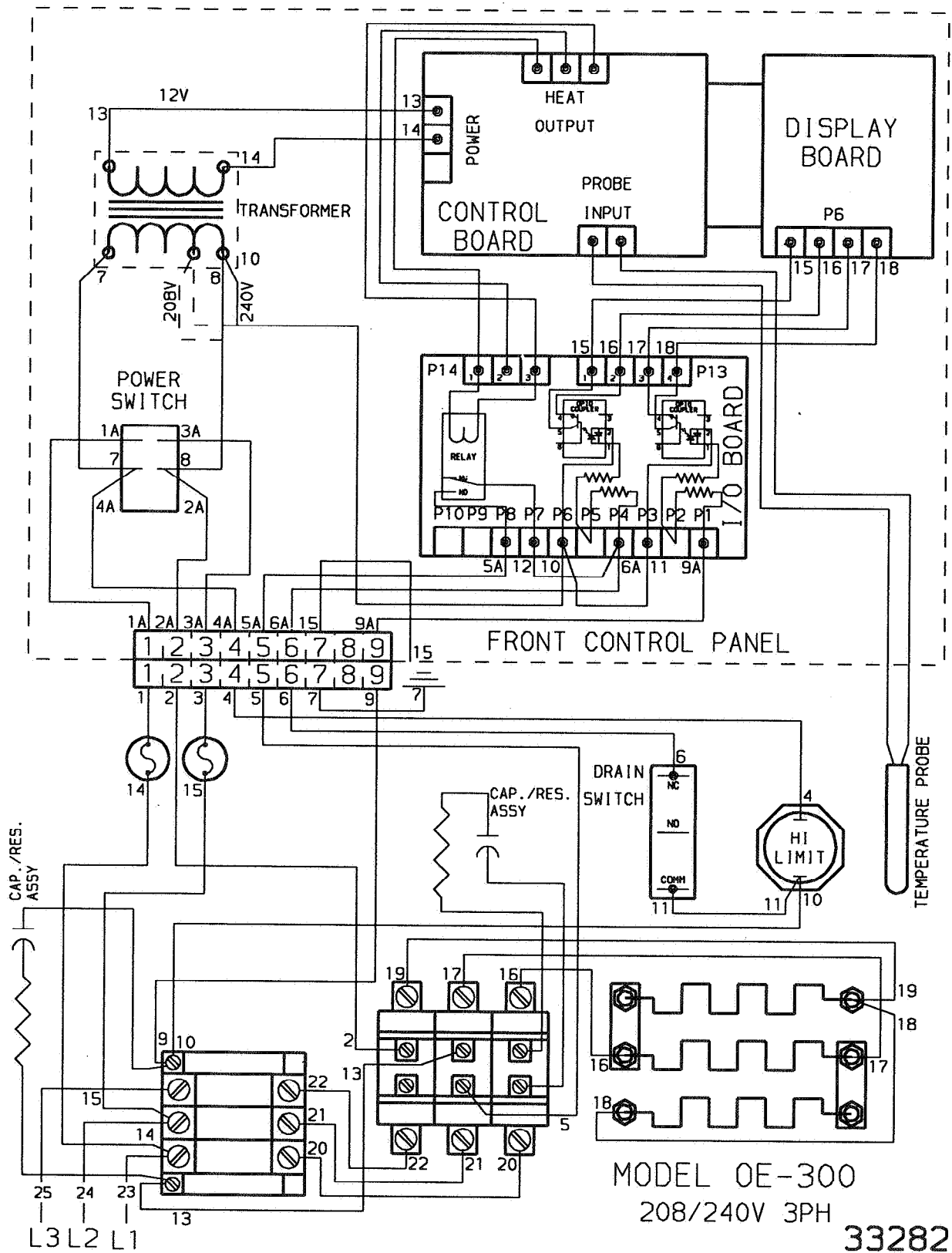

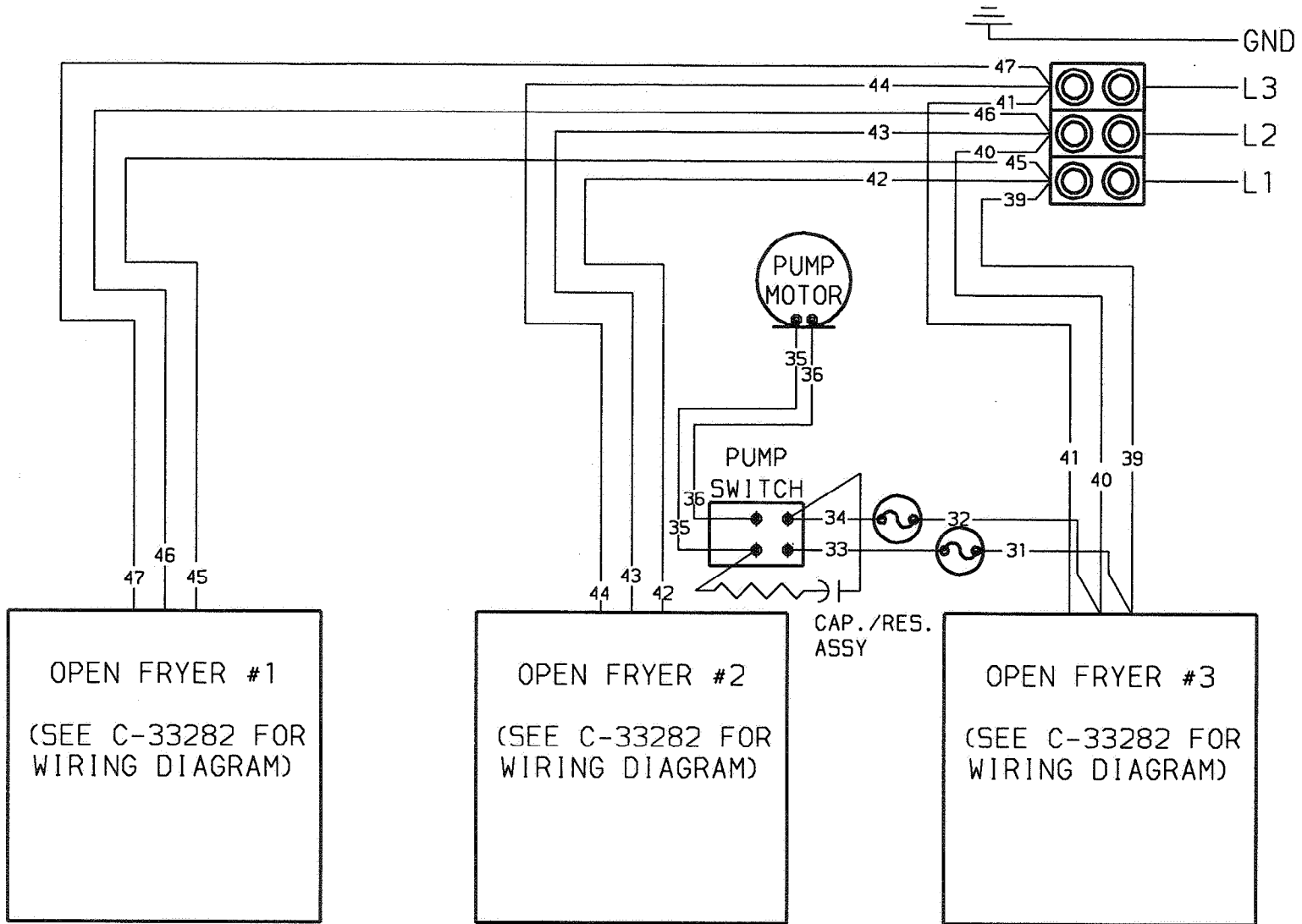

MODEL OE-303 SYSTEM
208/240V 3PH

33556

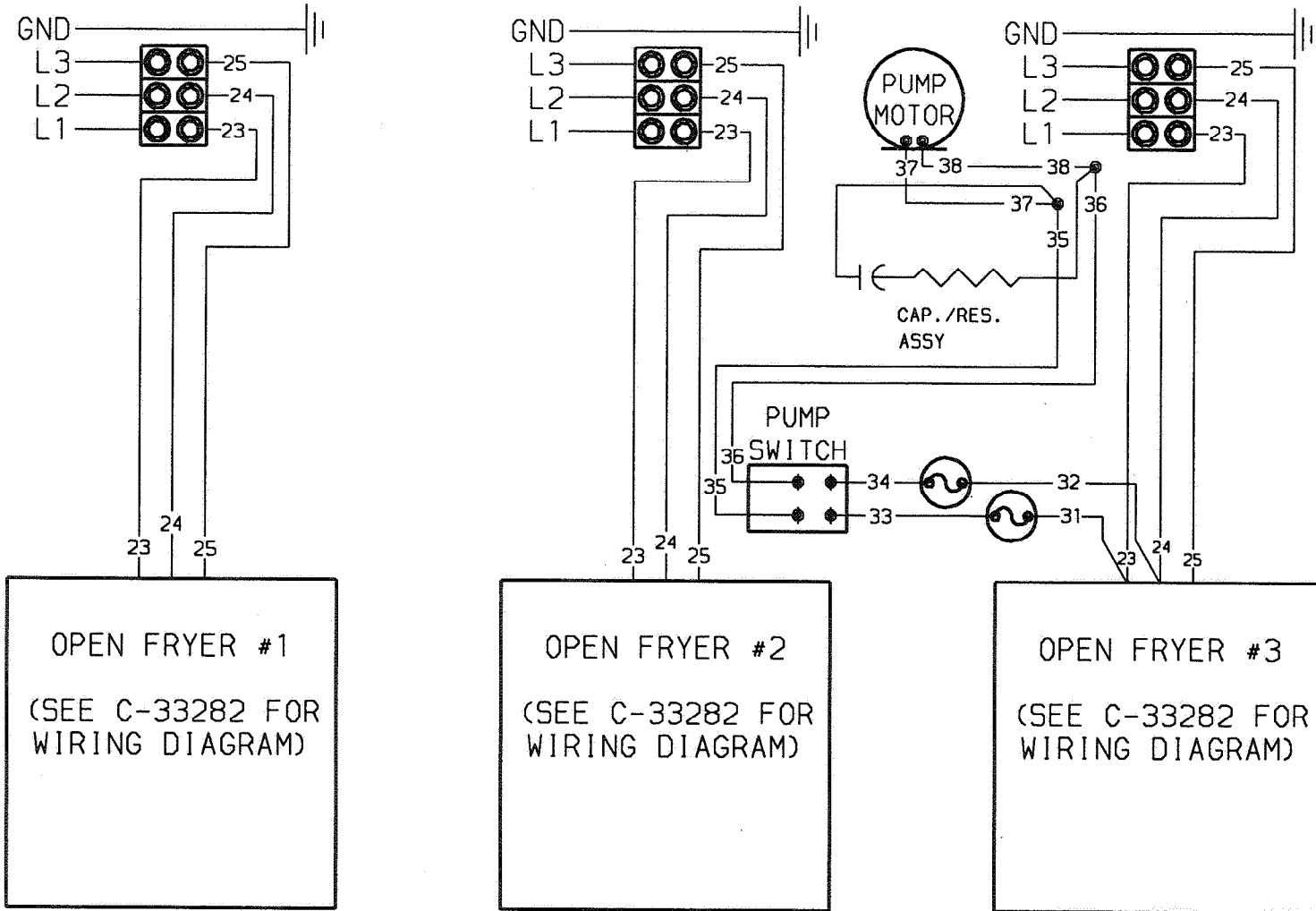

MODEL OE-303 SYSTEM
208/240V 3PH

33283

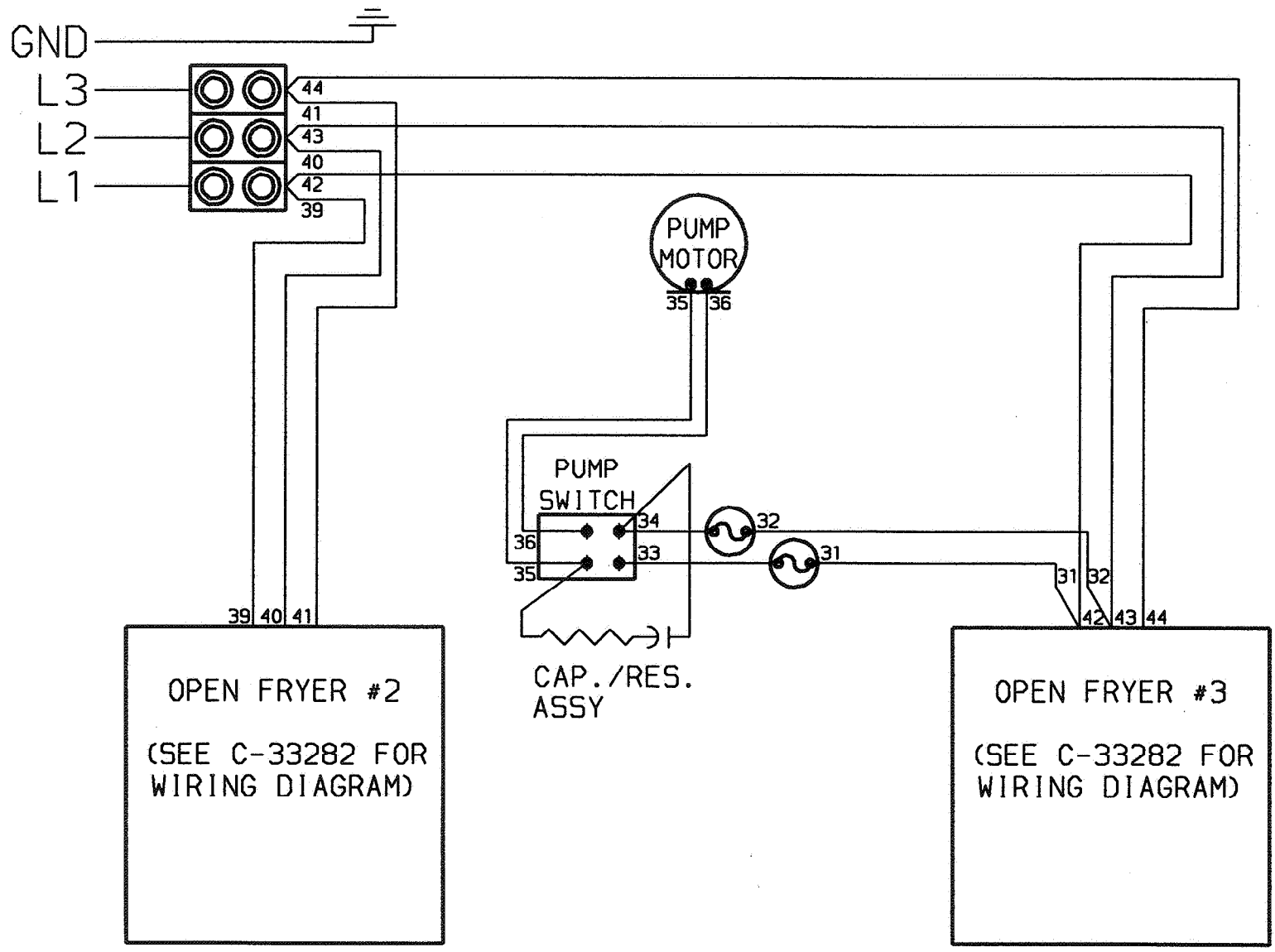

OPEN FRYER #2
(SEE C-33282 FOR
WIRING DIAGRAM)

OPEN FRYER #3
(SEE C-33282 FOR
WIRING DIAGRAM)

MODEL OE-302 SYSTEM
208/240V 3PH

33557

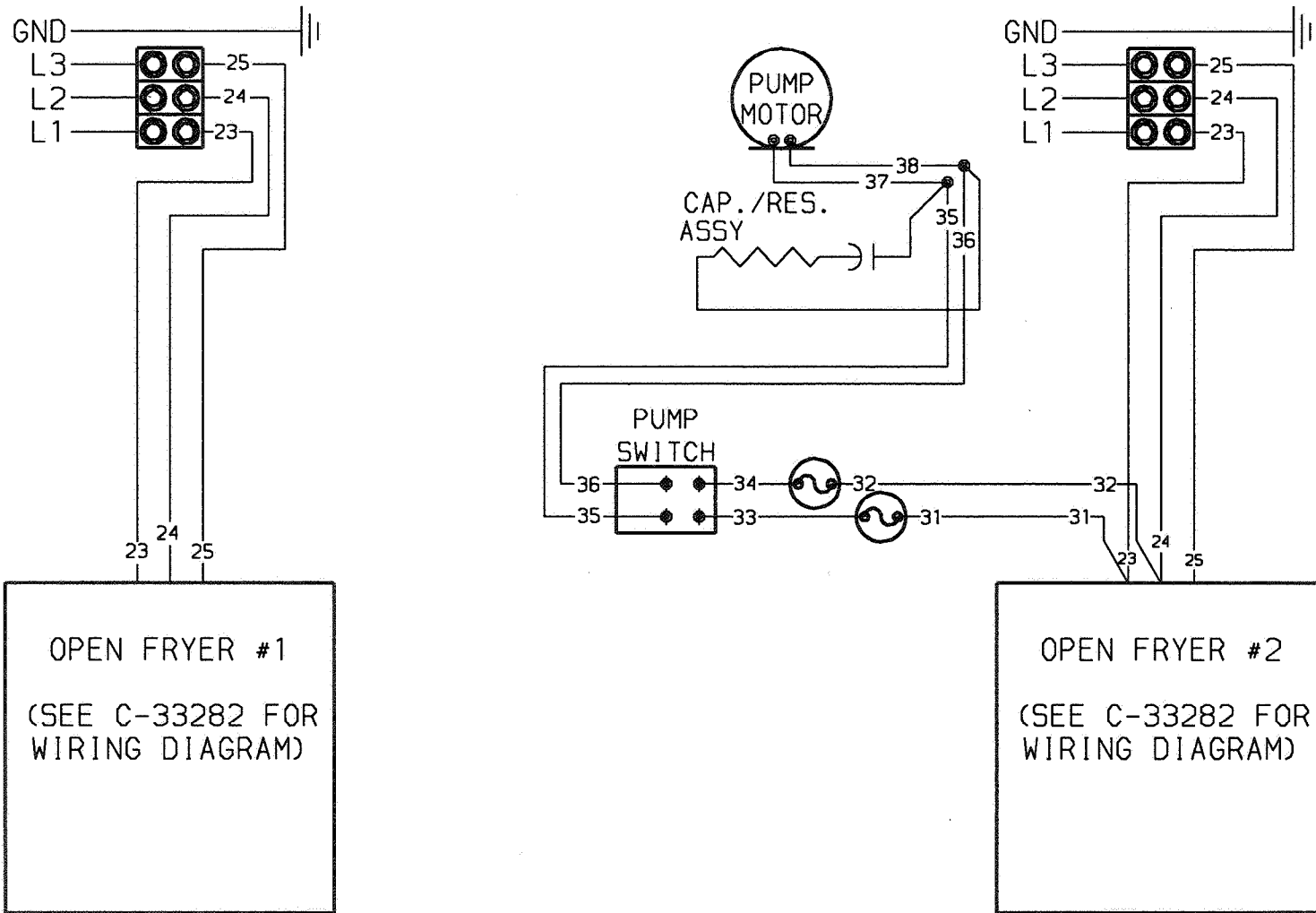

MODEL OE-302 SYSTEM
208/240V 3PH

33462

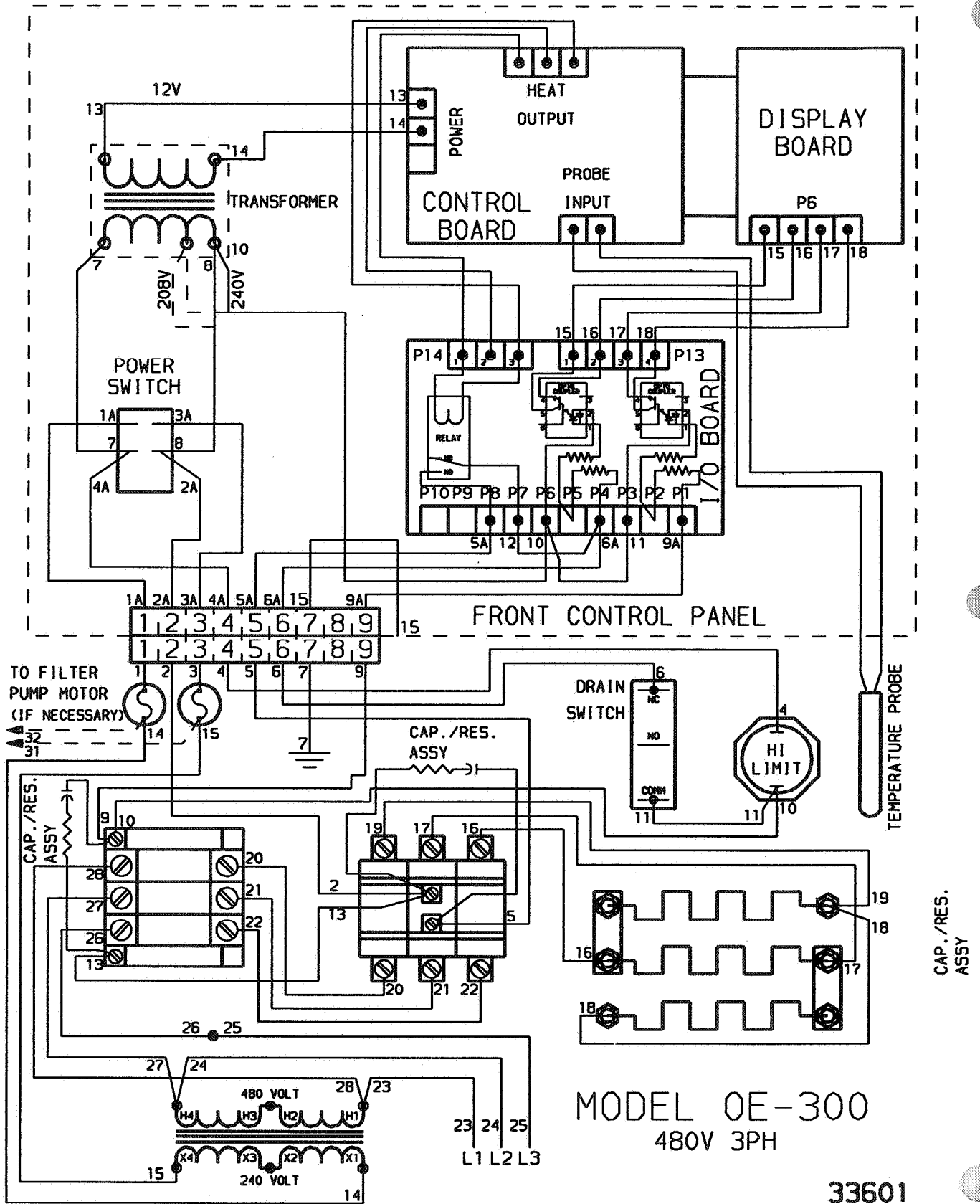

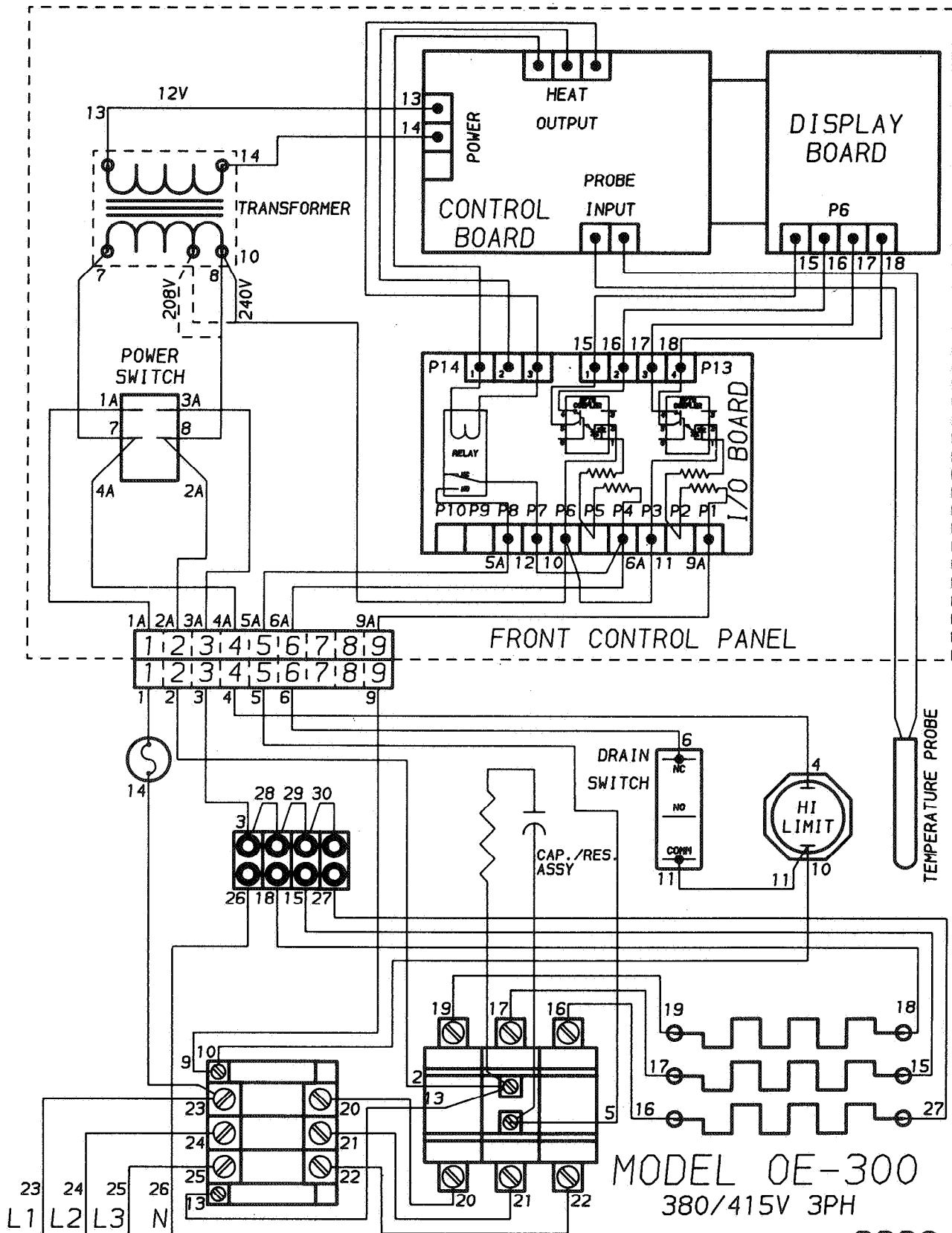

33284

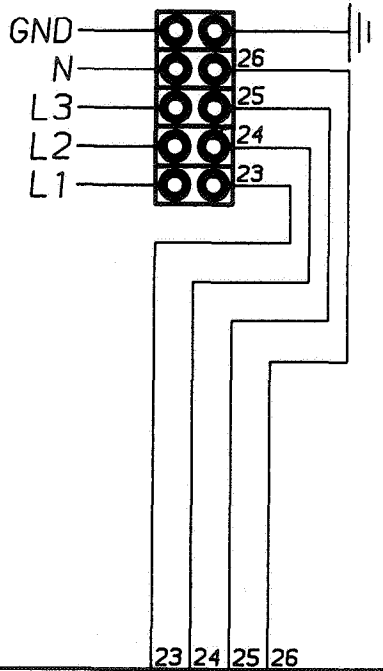

OPEN FRYER #1
 (SEE C-33284 FOR WIRING DIAGRAM)

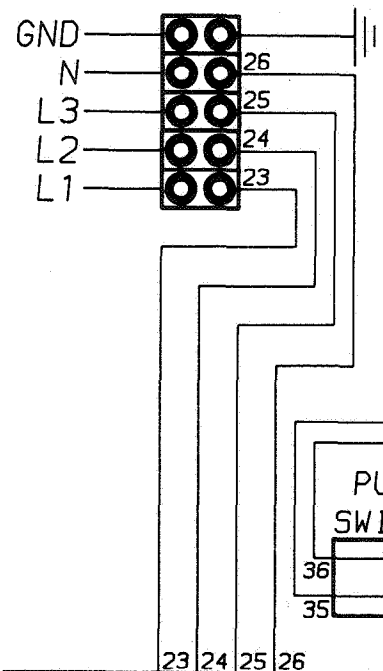

OPEN FRYER #2
 (SEE C-33284 FOR WIRING DIAGRAM)

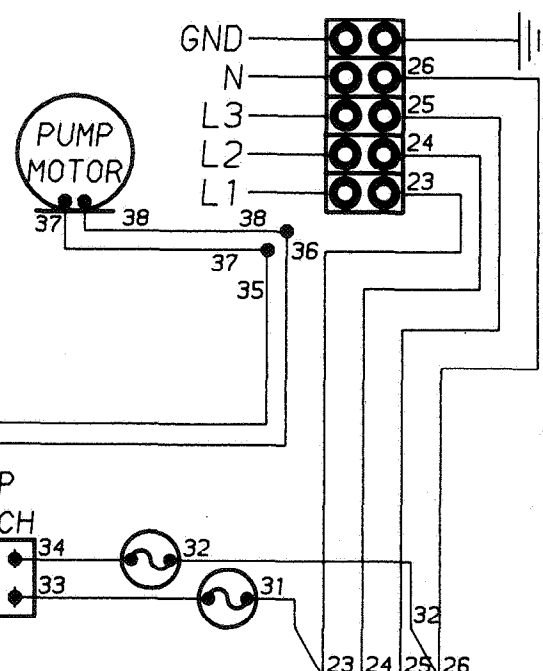

OPEN FRYER #3
 (SEE C-33284 FOR WIRING DIAGRAM)

MODEL OE-303 SYSTEM

208/380V 3PH

OR

240/415V 3PH

33285

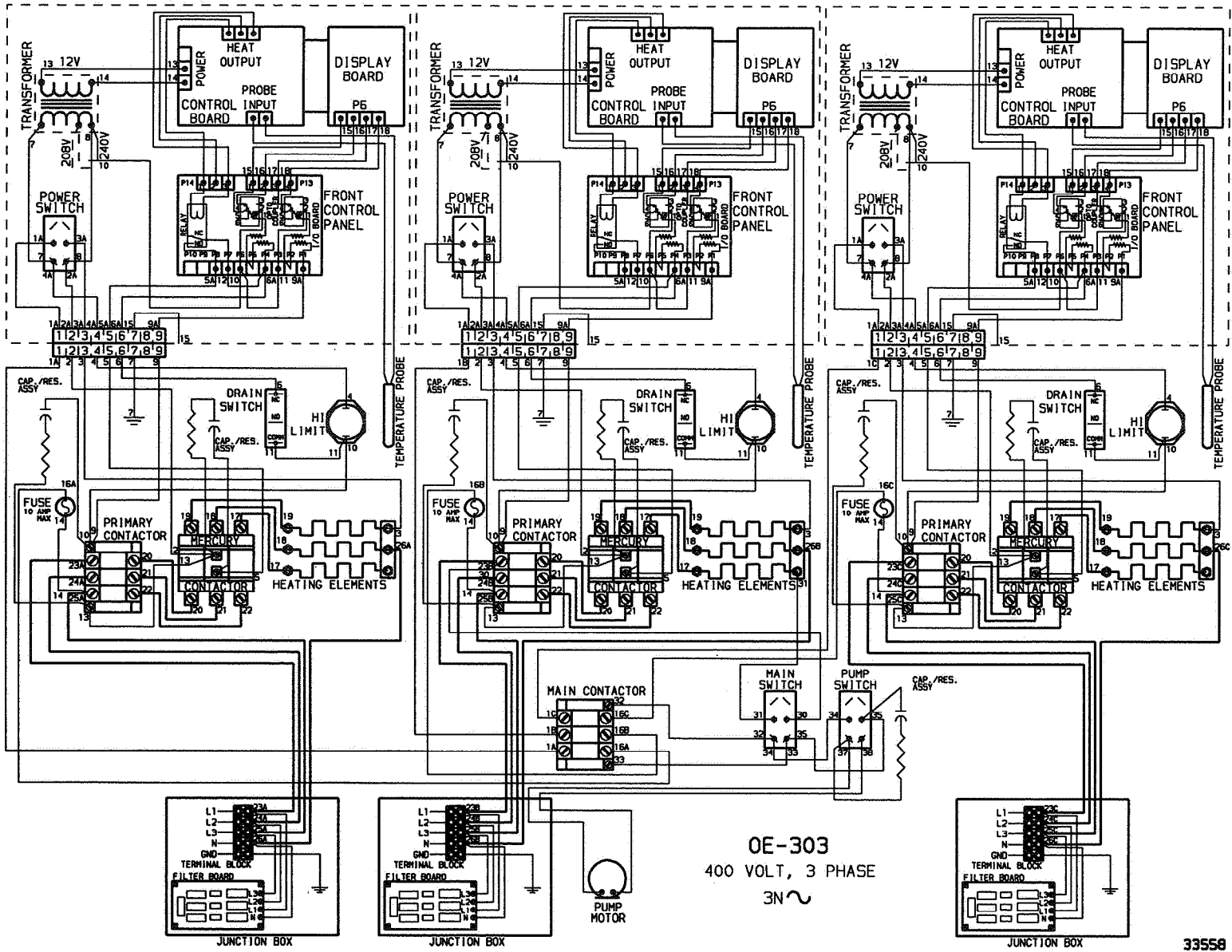

33558

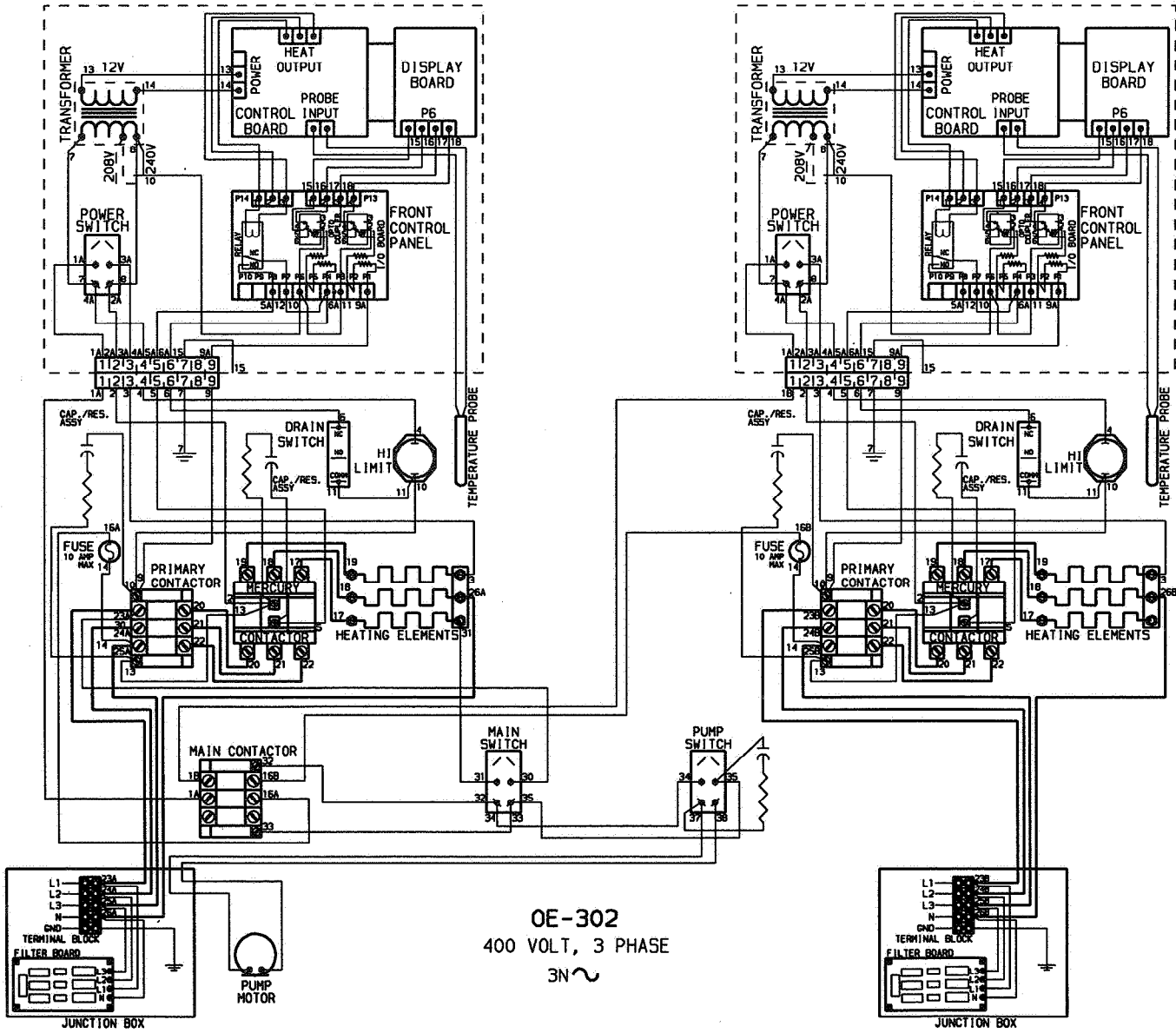

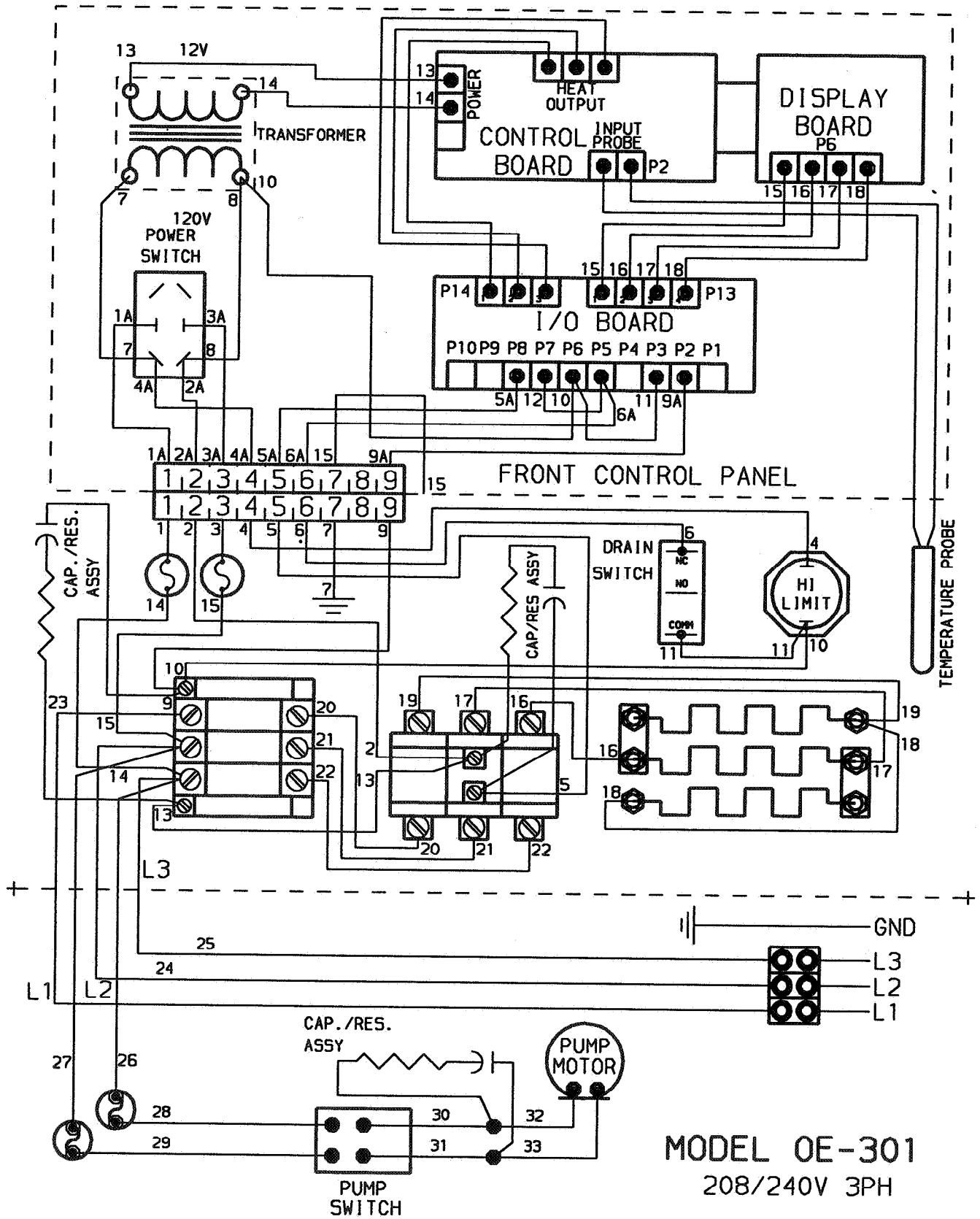

MODEL OE-301
208/240V 3PH

33726

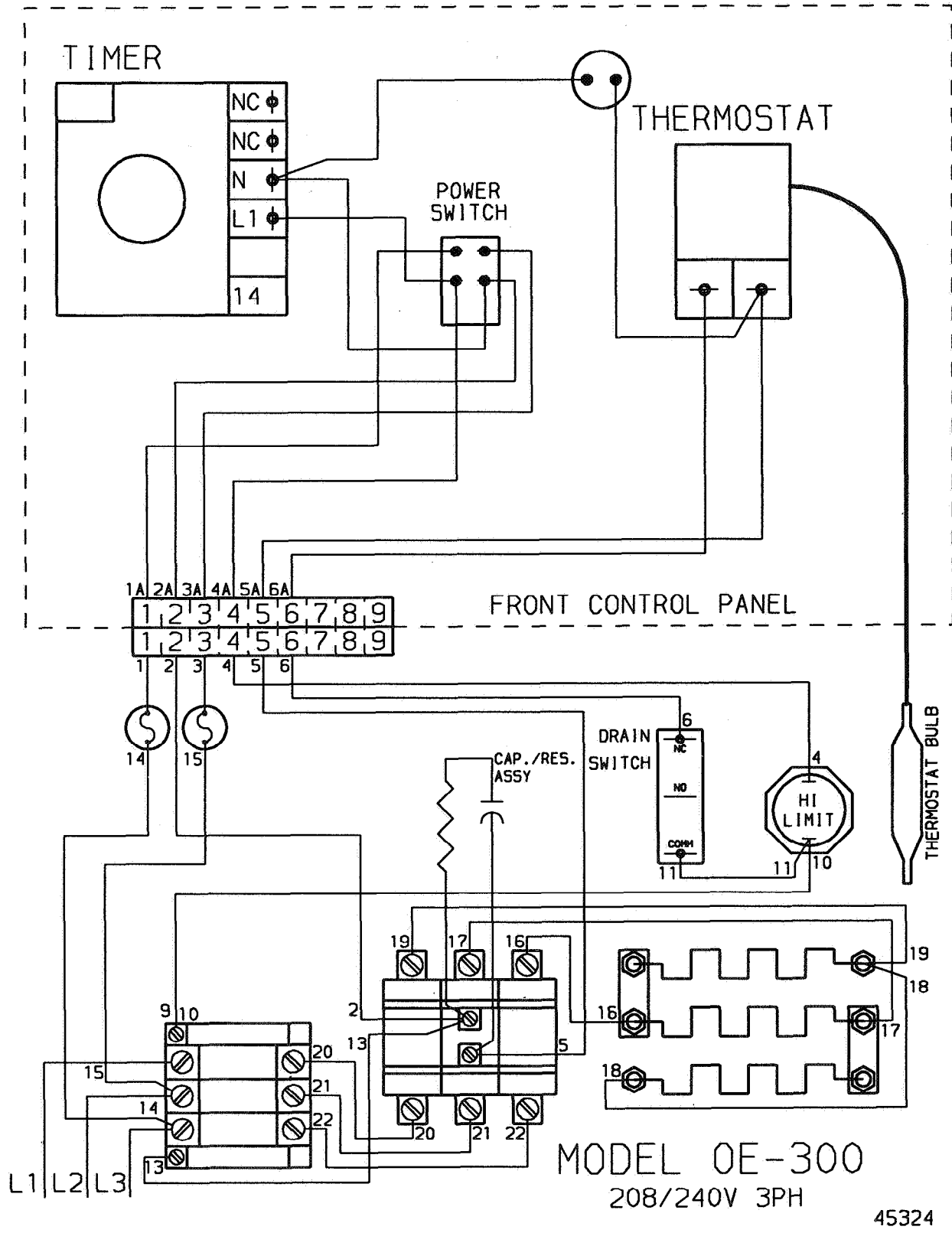

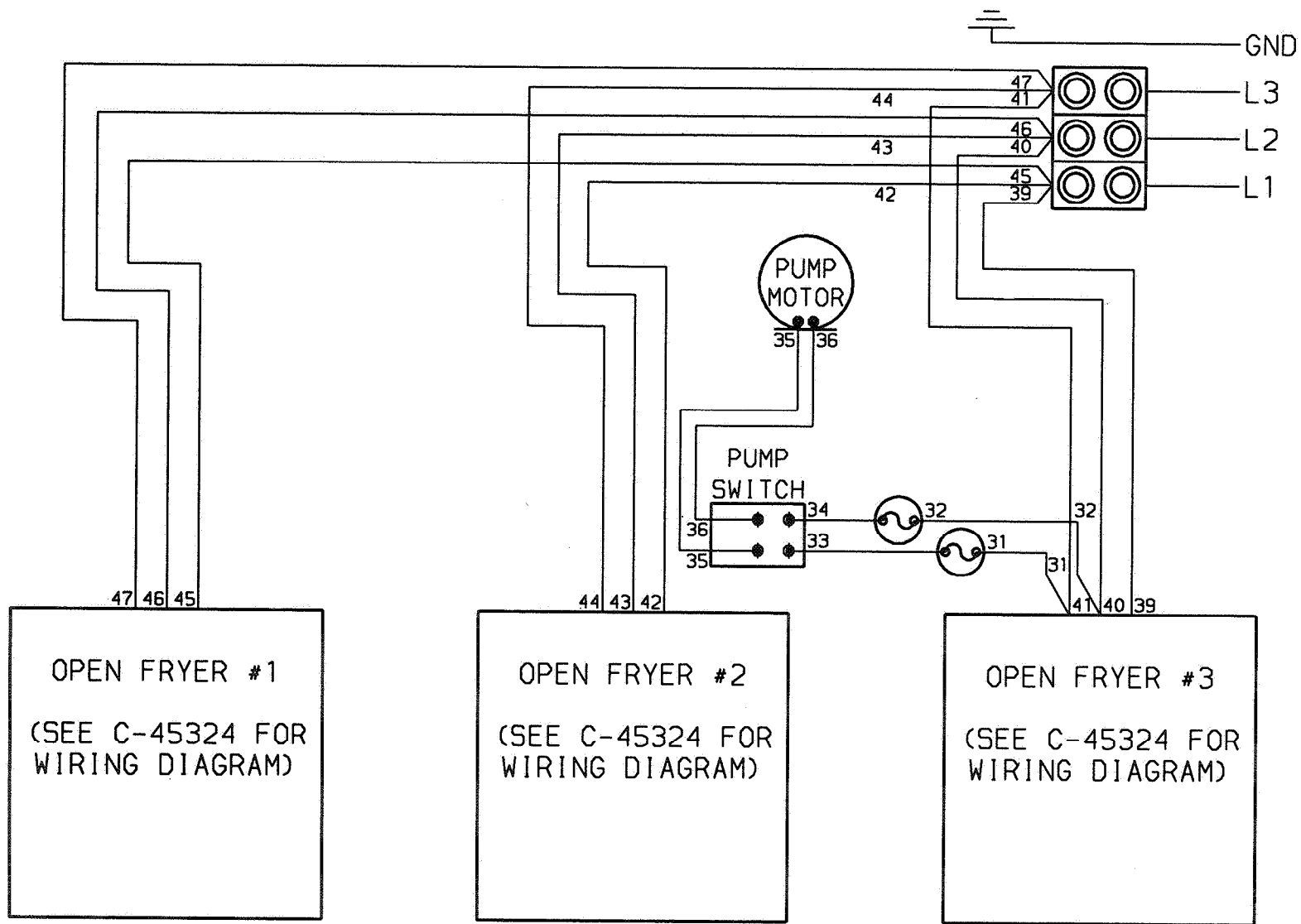

MODEL OE-303 SYSTEM
208/240V 3PH

45372

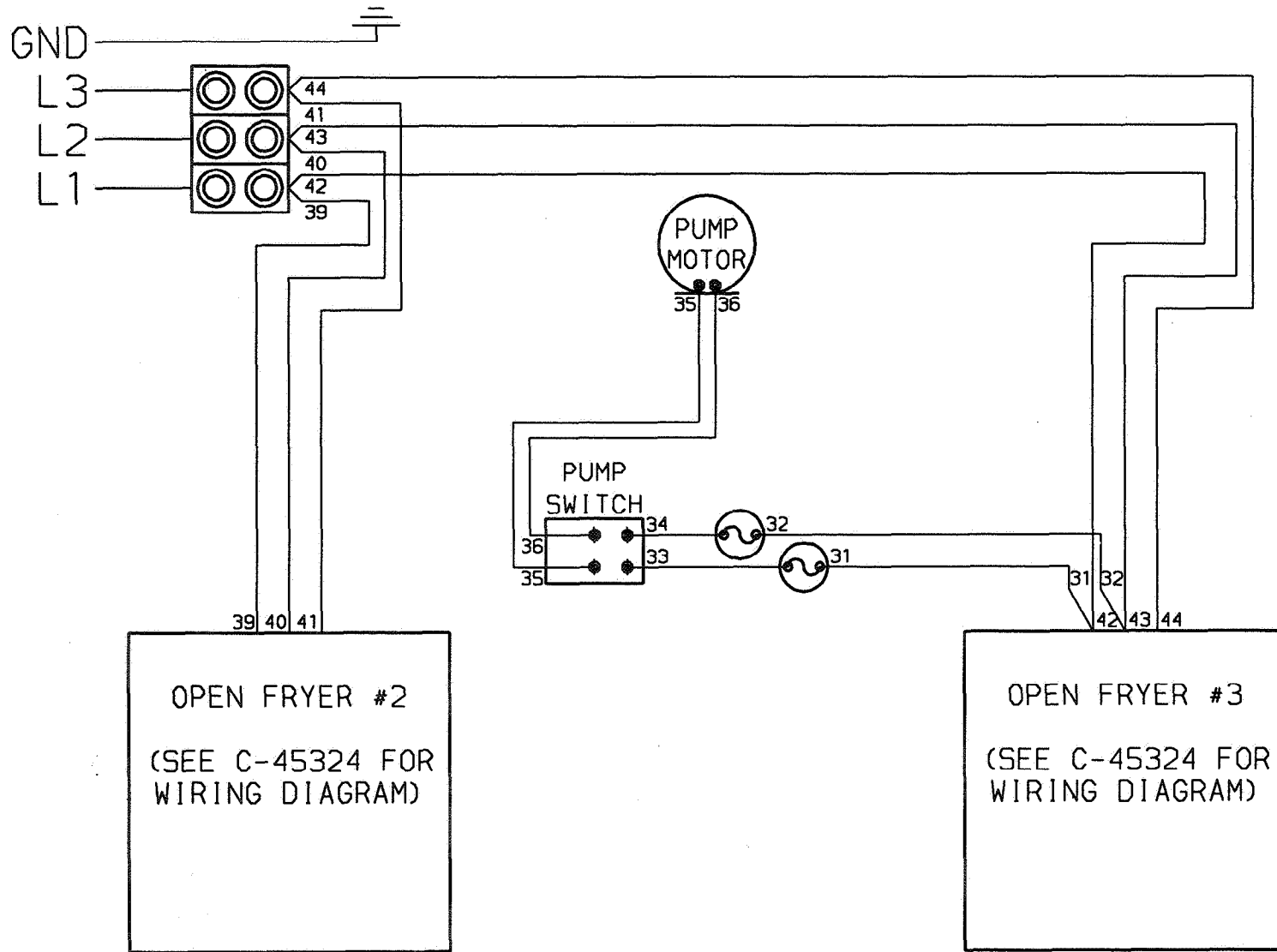

MODEL OE-302 SYSTEM
208/240V 3PH

45377

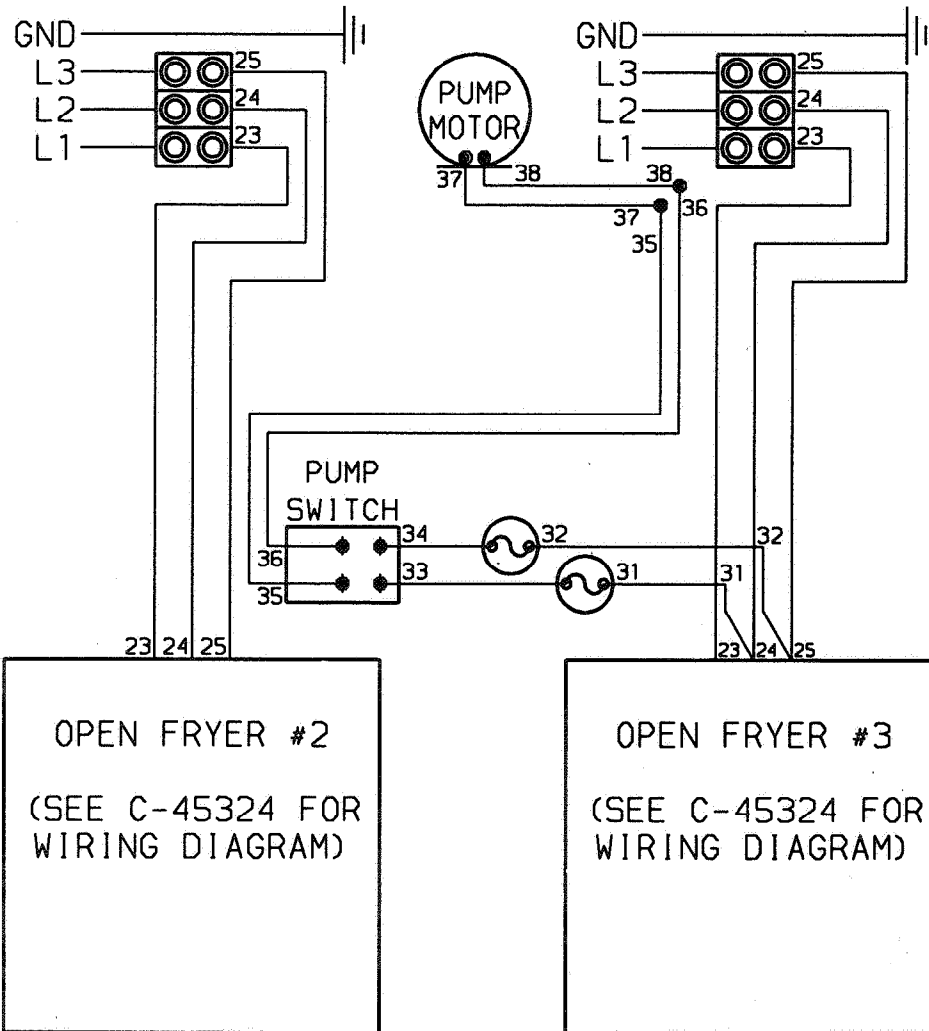
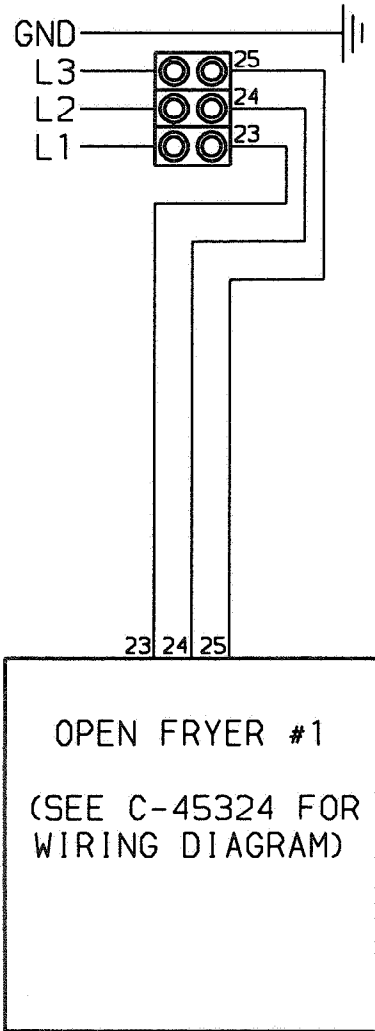

MODEL OE-300 SYSTEM
208/240V 3PH

45286

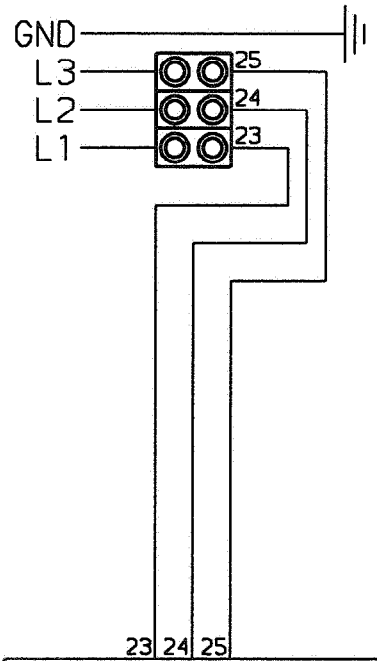

OPEN FRYER #1
 (SEE C-45324 FOR
 WIRING DIAGRAM)

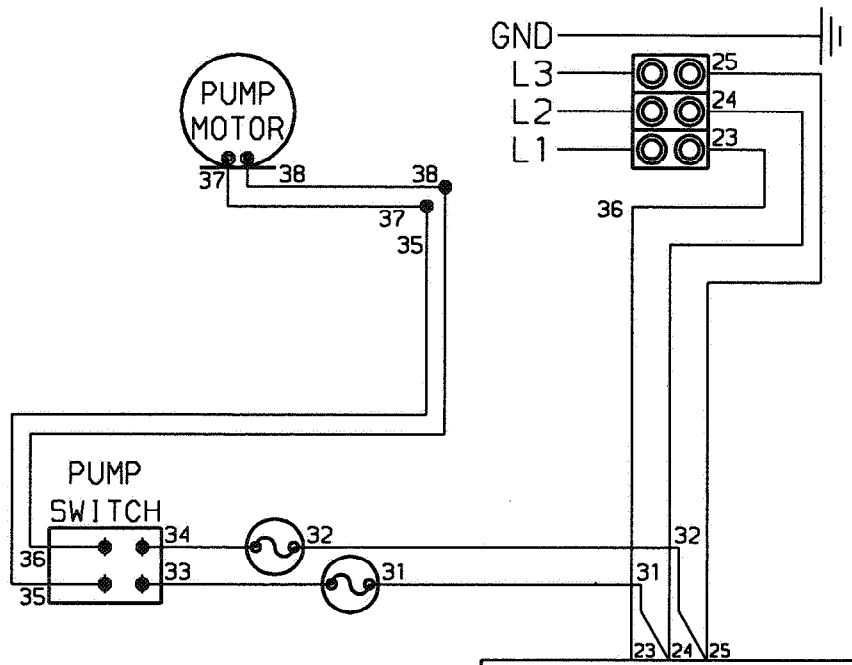

OPEN FRYER #2
 (SEE C-45324 FOR
 WIRING DIAGRAM)

MODEL OE-302 SYSTEM
 208/240V 3PH

45378

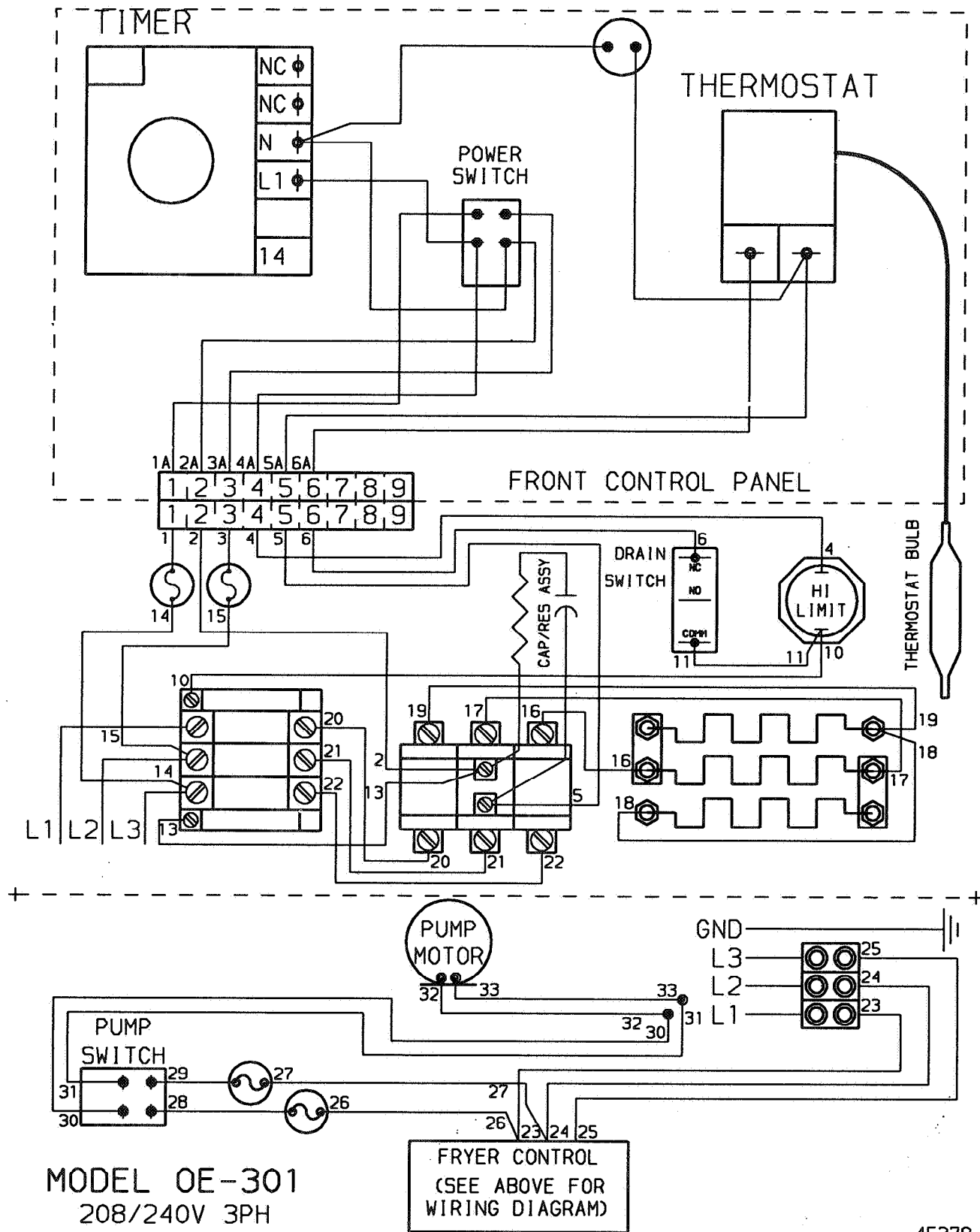

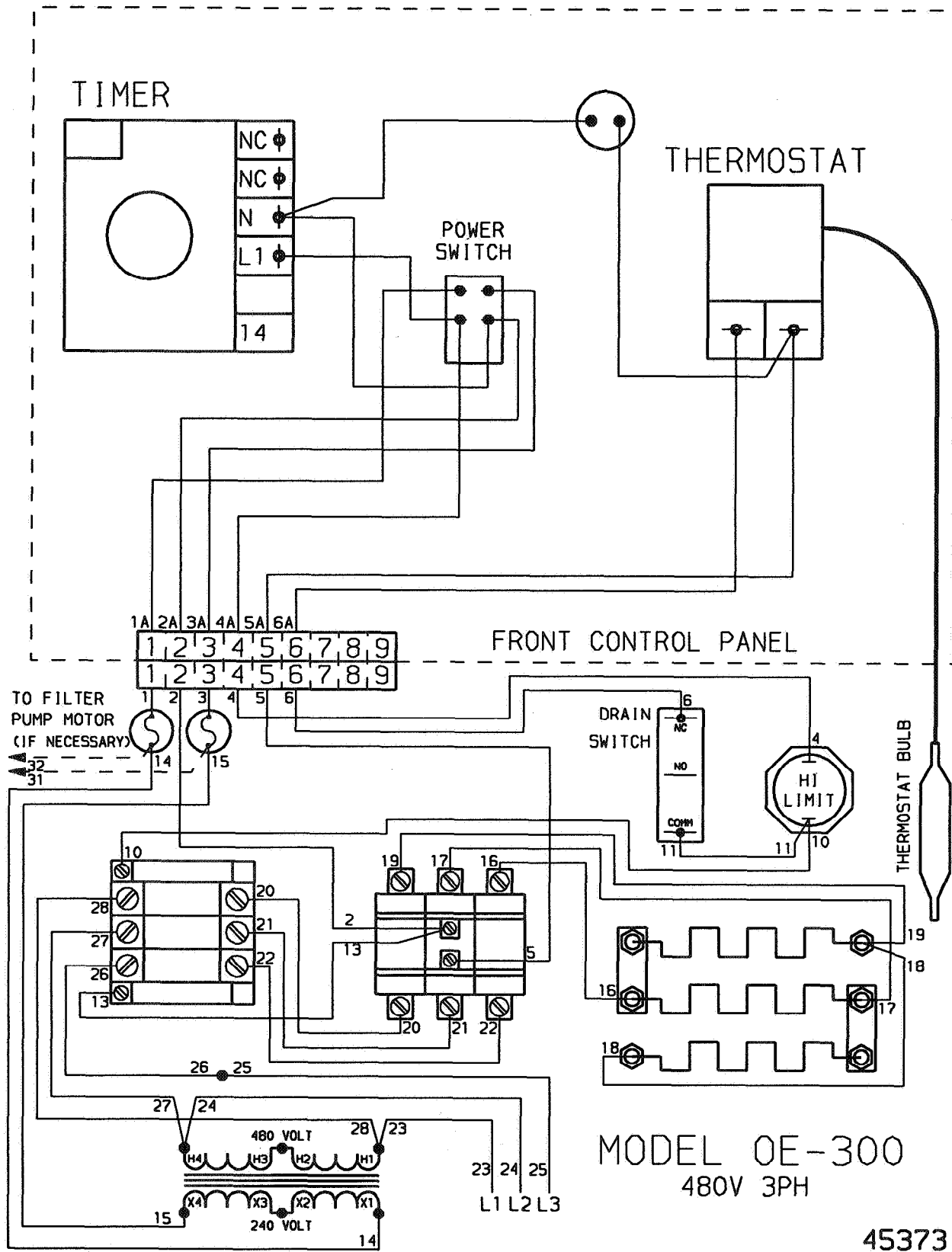

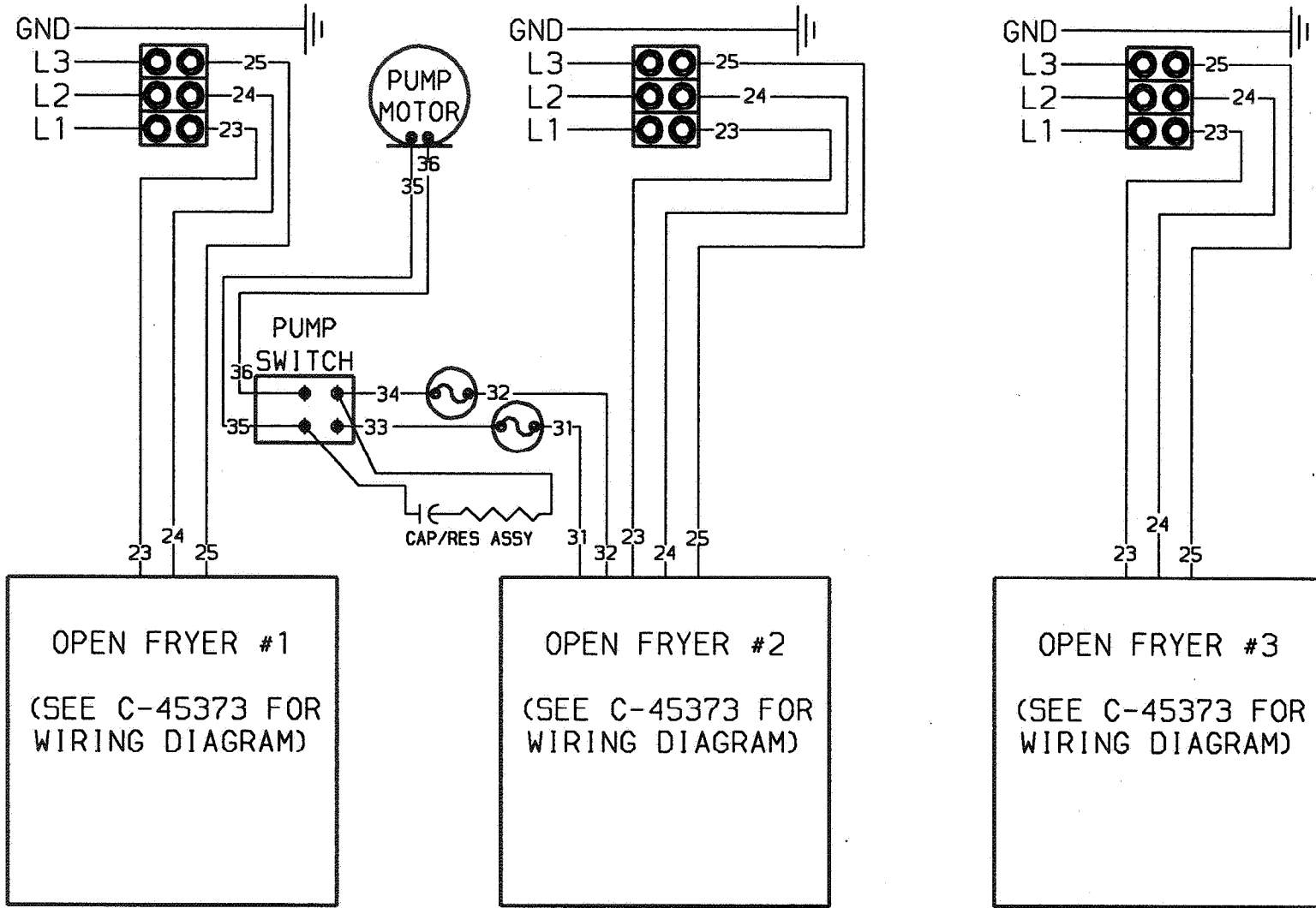

MODEL OE-303 SYSTEM
480V 3PH

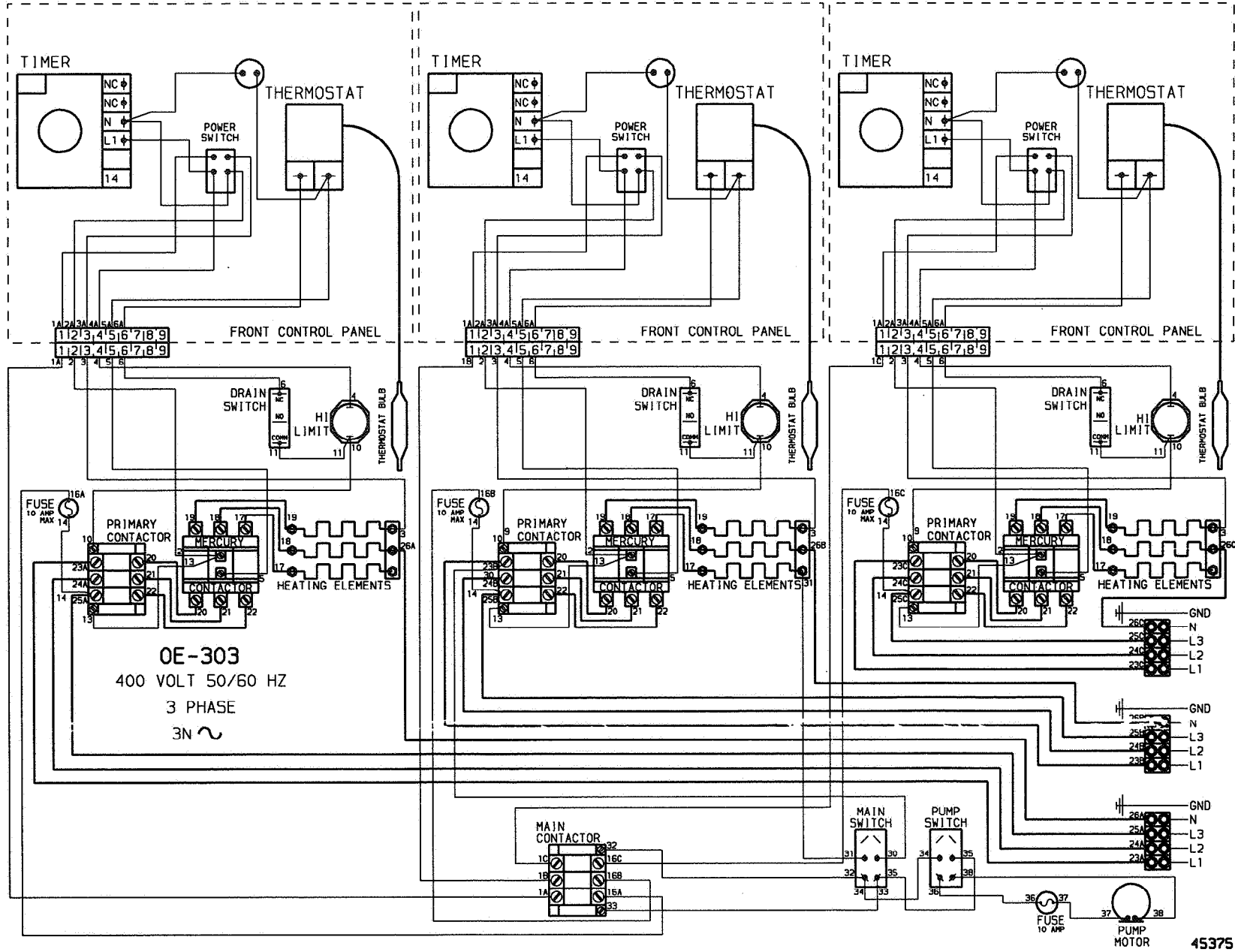

45375

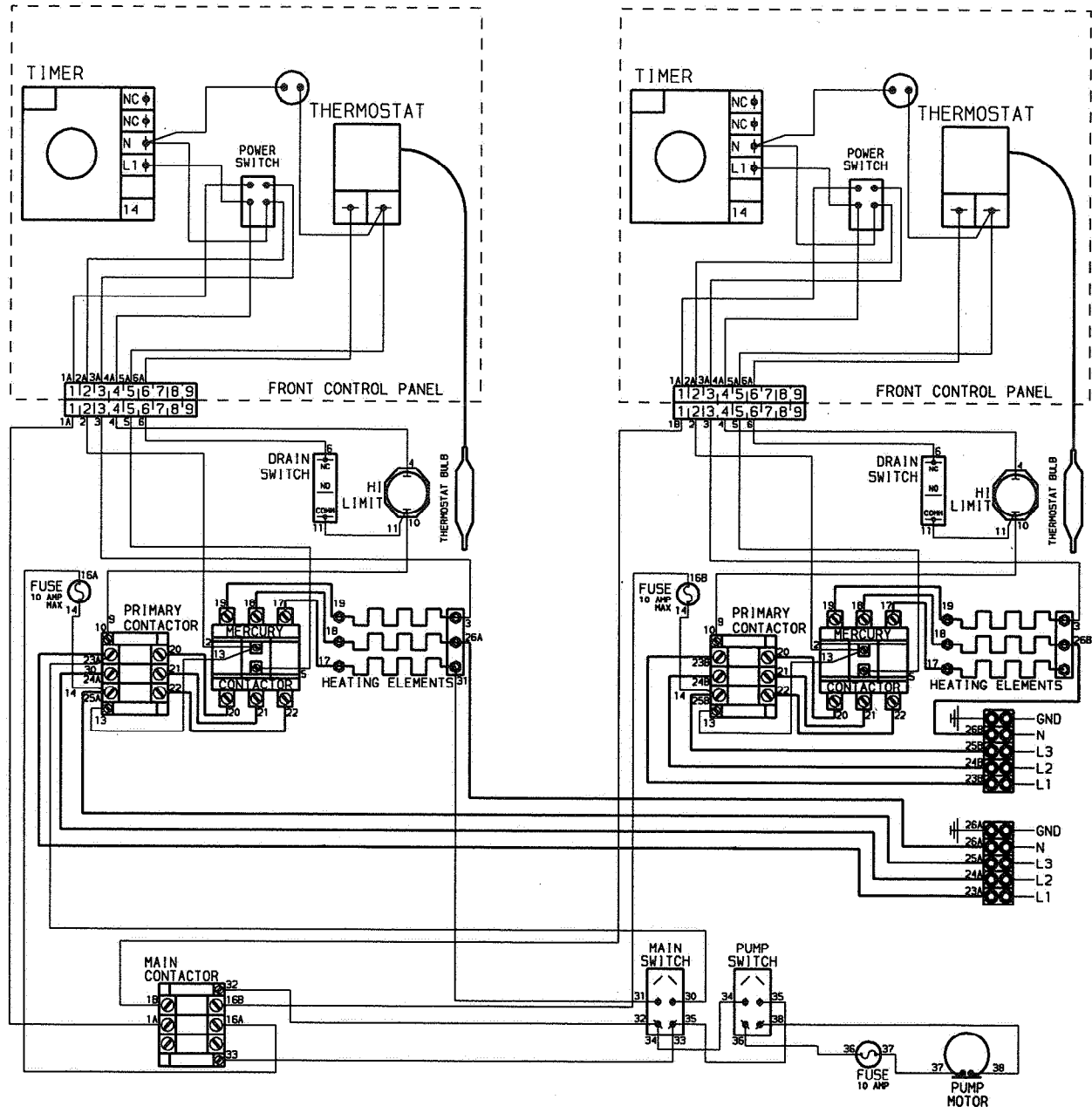

OE-302
 400 VOLT 50/60 HZ
 3 PHASE
 3N~

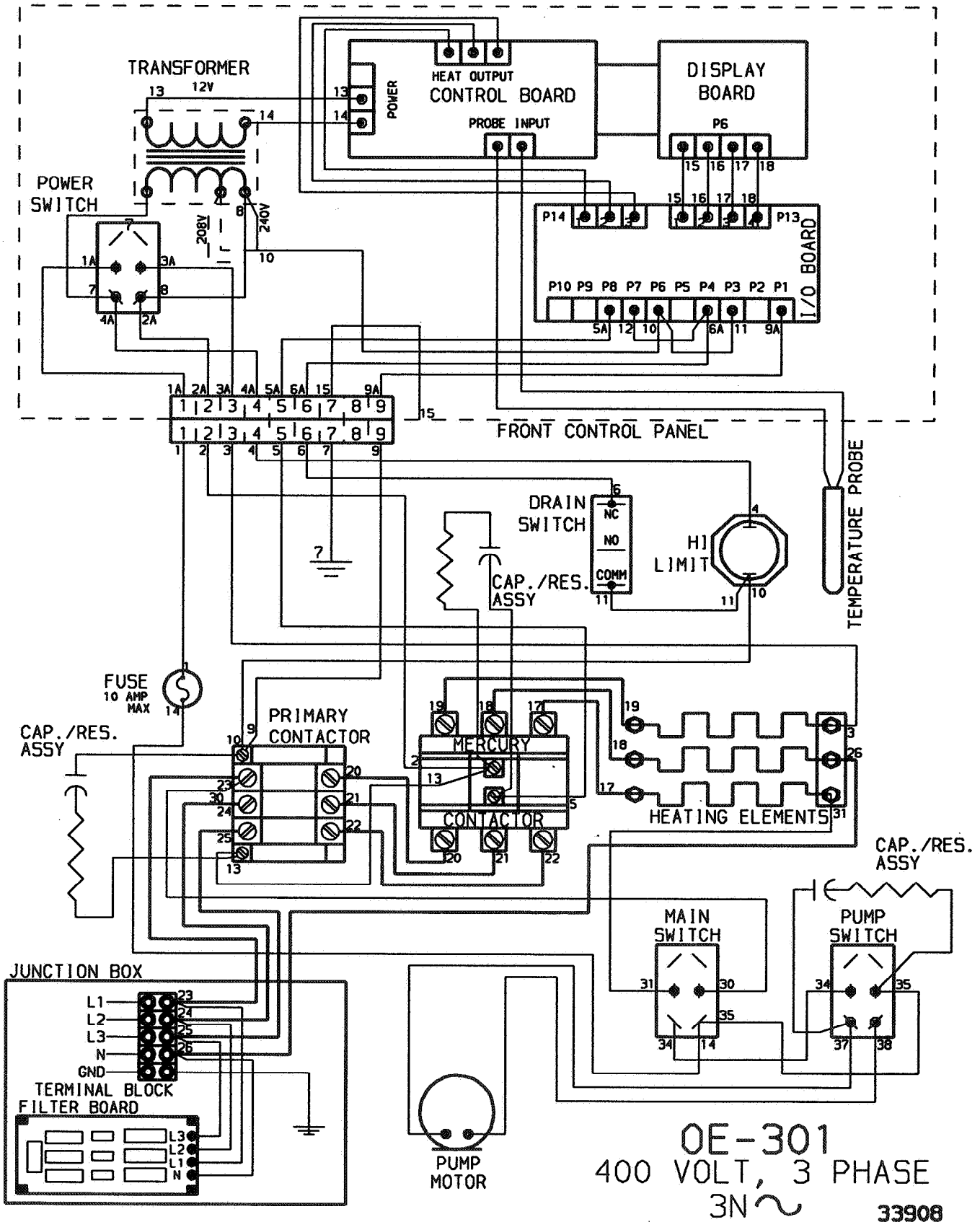

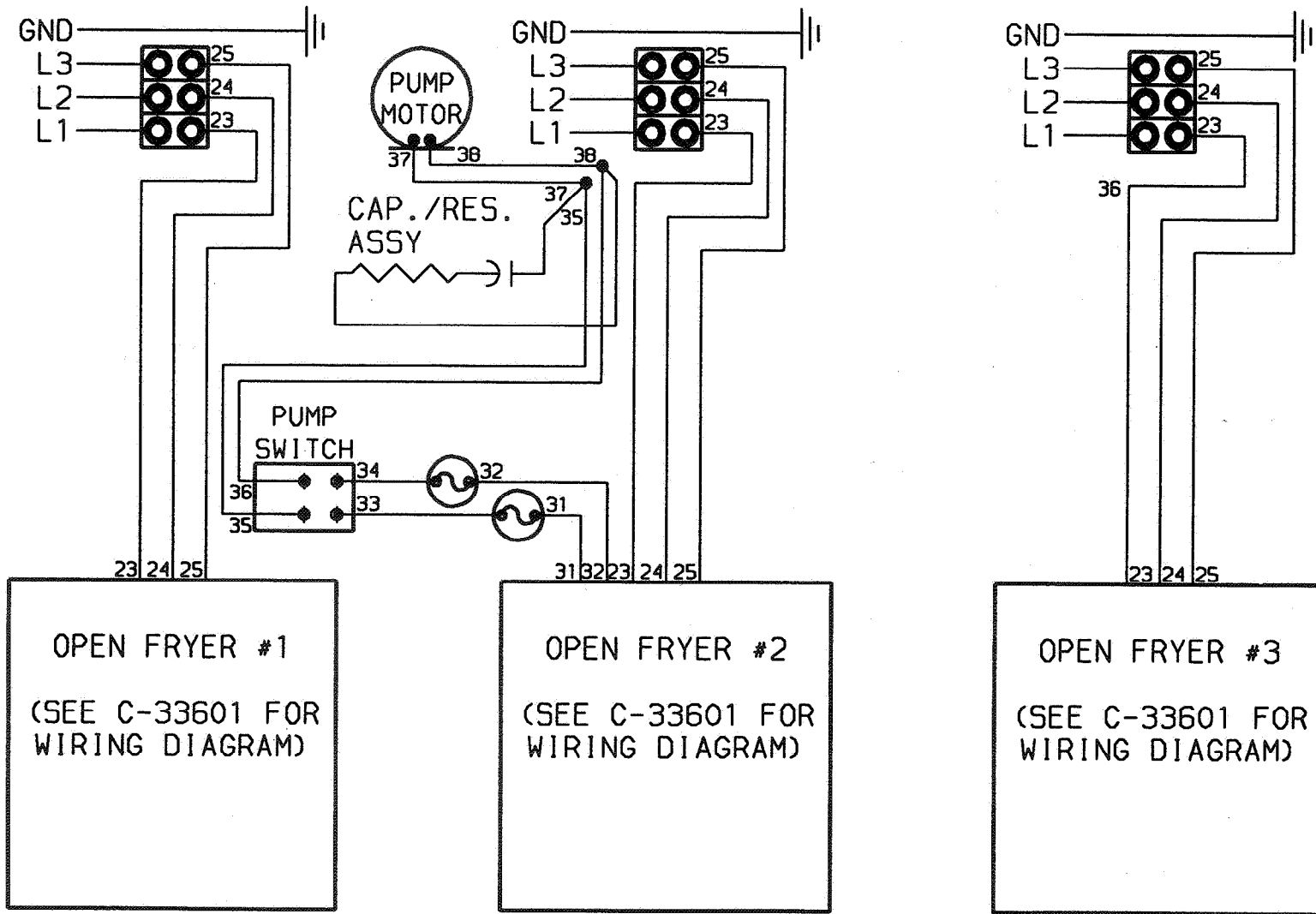

MODEL OE-303 SYSTEM
480V 3PH

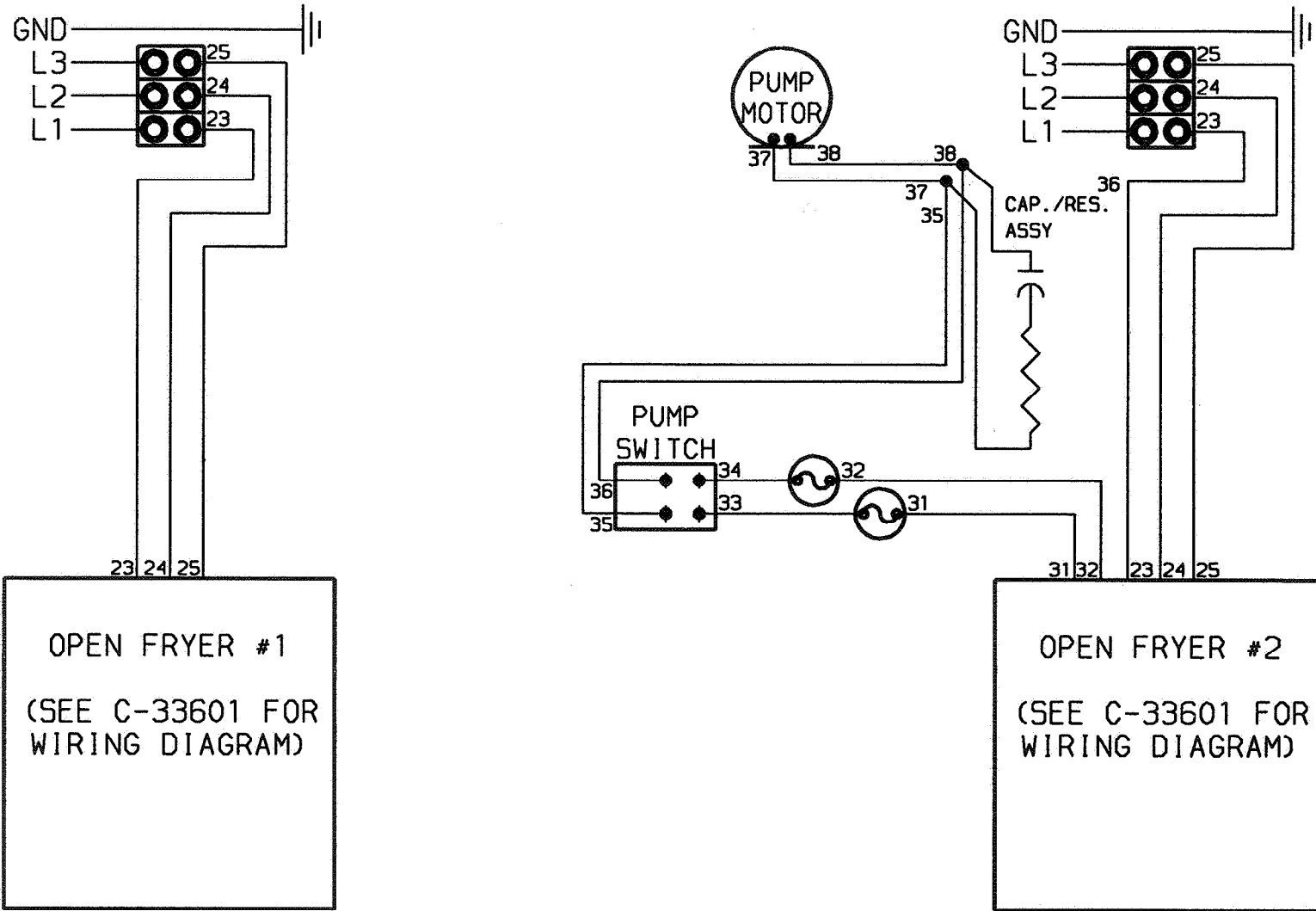

MODEL OE-302 SYSTEM
480V 3PH

33603

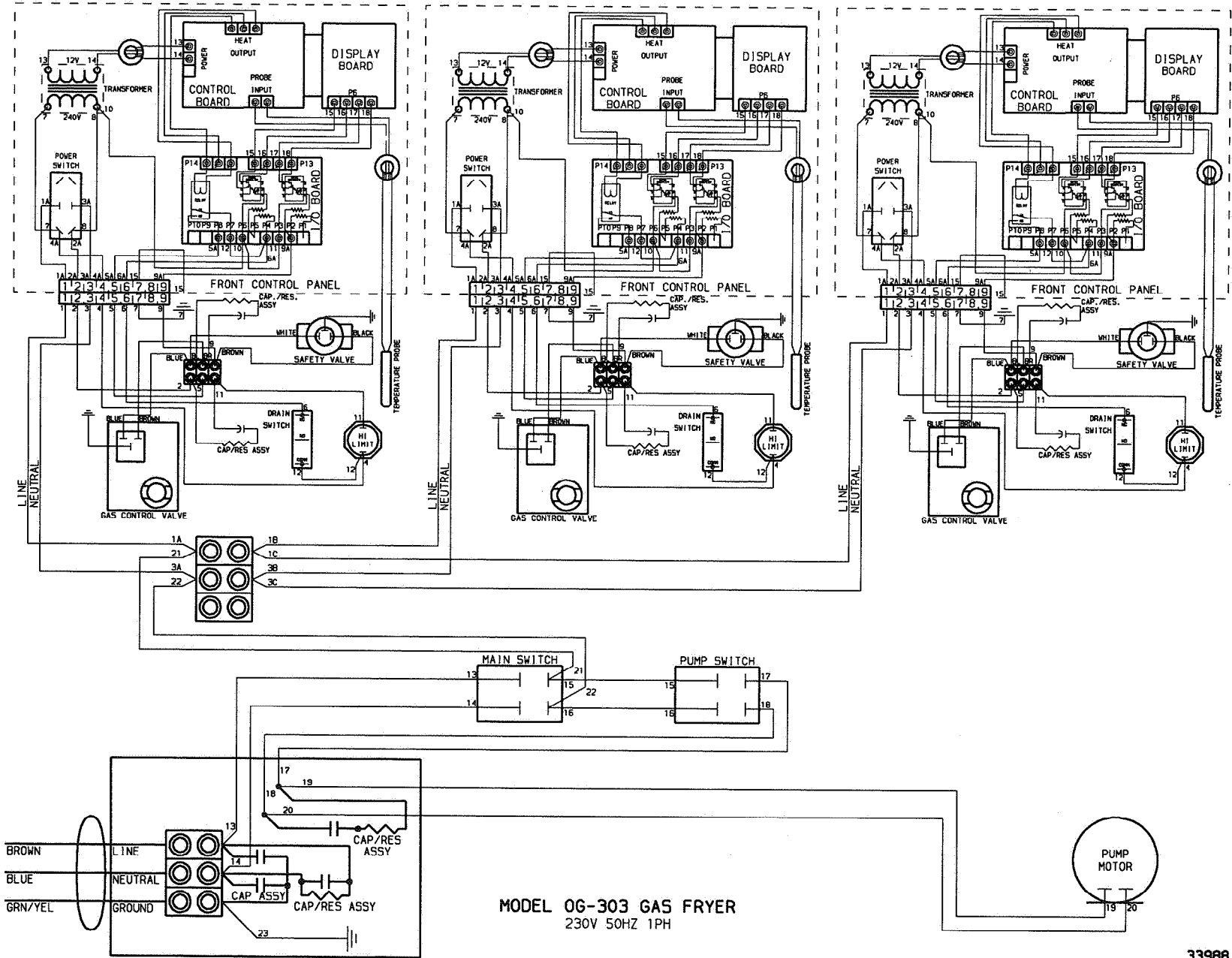

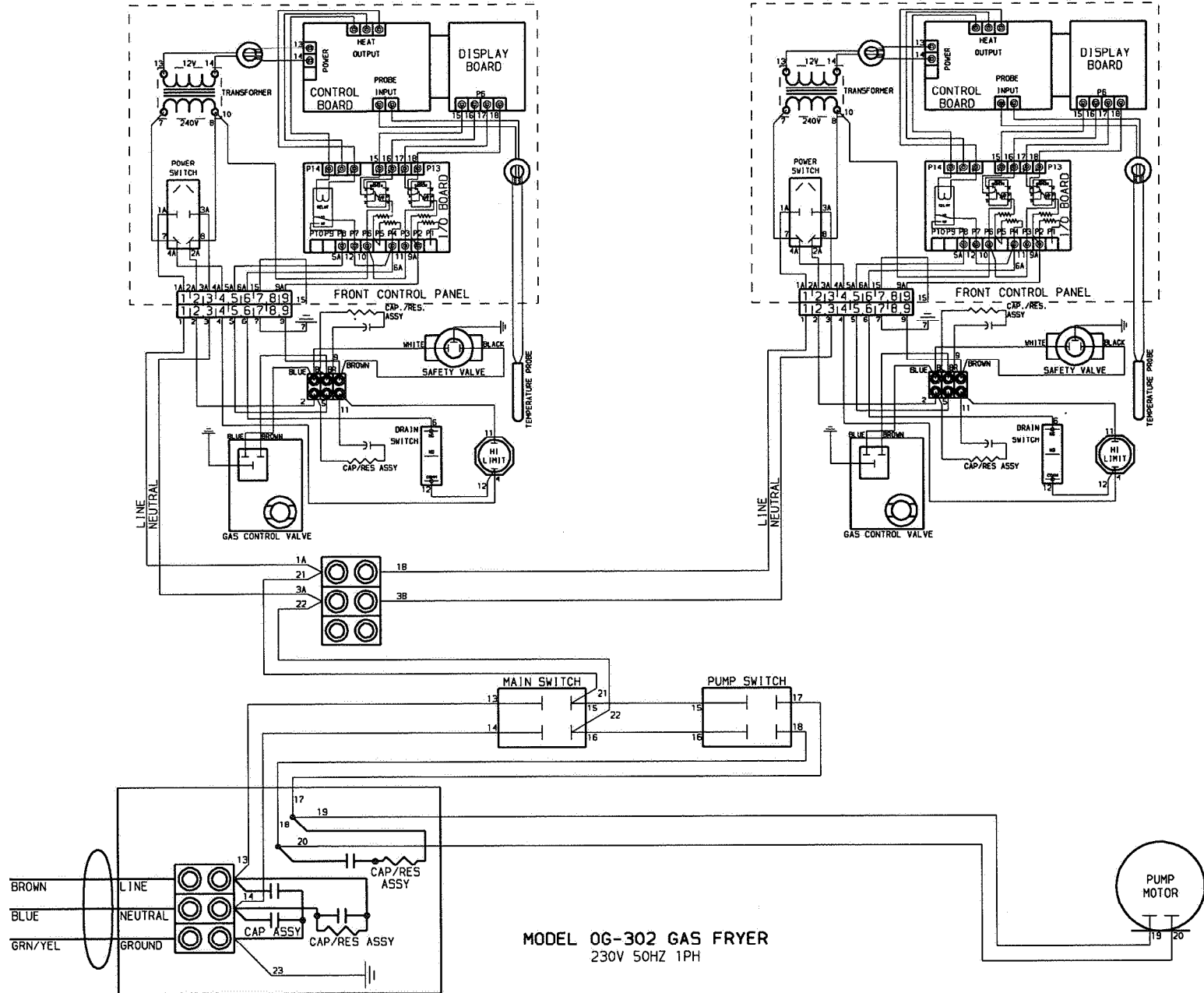

MODEL OG-302 GAS FRYER
230V 50HZ 1PH

33989

LIMITED WARRANTY FOR HENNY PENNY APPLIANCES

Subject to the following conditions, Henny Penny Corporation makes the following limited warranties to the original purchaser only for Henny Penny appliances and replacement parts:

NEW EQUIPMENT: Any part of a new appliance, except lamps and fuses, which proves to be defective in material or workmanship within two (2) years from date of original installation, will be repaired or replaced without charge F.O.B. factory, Eaton, Ohio, or F.O.B. authorized distributor. To validate this warranty, the registration card for the appliance must be mailed to Henny Penny within ten (10) days after installation.

REPLACEMENT PARTS: Any appliance replacement part, except lamps and fuses, which proves to be defective in material or workmanship within ninety (90) days from date of original installation will be repaired or replaced without charge F.O.B. factory, Eaton, Ohio, or F.O.B. authorized distributor.

The warranty for new equipment and replacement parts covers only the repair or replacement of the defective part and does not include any labor charges for the removal and installation of any parts, travel or other expenses incidental to the repair or replacement of a part.

EXTENDED FRYPOT WARRANTY: Henny Penny will replace any frypot that fails due to manufacturing or workmanship issues for a period of up to seven (7) years from date of manufacture. This warranty shall not cover any frypot that fails due to any misuse or abuse, such as heating of the frypot without shortening.

0 TO 3 YEARS: During this time, any frypot that fails due to manufacturing or workmanship issues will be replaced at no charge for parts, labor, or freight. Henny Penny will either install a new frypot at no cost or provide a new or reconditioned replacement fryer at no cost.

3 TO 7 YEARS: During this time, any frypot that fails due to manufacturing or workmanship issues will be replaced at no charge for the frypot only. Any freight charges and labor costs to install the new frypot as well as the cost of any other parts replaced, such as insulation, thermal sensors, high limits, fittings, and hardware, will be the responsibility of the owner.

Any claim must be represented to either Henny Penny or the distributor from whom the appliance was purchased. No allowance will be granted for repairs made by anyone else without Henny Penny's written consent. If damage occurs during shipping, notify the sender at once so that a claim may be filed.

THE ABOVE LIMITED WARRANTY SETS FORTH THE SOLE REMEDY AGAINST HENNY PENNY FOR ANY BREACH OF WARRANTY OR OTHER TERM. BUYER AGREES THAT NO OTHER REMEDY (INCLUDING CLAIMS FOR ANY INCIDENTAL OR CONSEQUENTIAL DAMAGES) SHALL BE AVAILABLE.

The above limited warranty does not apply (a) to damage resulting from accident, alteration, misuse, or abuse; (b) if the equipment's serial number is removed or defaced; or (c) for lamps and fuses. THE ABOVE LIMITED WARRANTY IS EXPRESSLY IN LIEU OF ALL OTHER WARRANTIES, EXPRESS OR IMPLIED, INCLUDING MERCHANTABILITY AND FITNESS, AND ALL OTHER WARRANTIES ARE EXCLUDED. HENNY PENNY NEITHER ASSUMES NOR AUTHORIZES ANY PERSON TO ASSUME FOR IT ANY OTHER OBLIGATION OR LIABILITY.



SECTION 7. PARTS INFORMATION

7-1. INTRODUCTION

This section identifies and lists the replaceable parts of the Henny Penny 3-Well Open Fryer.

7-2. GENUINE PARTS

Use only genuine Henny Penny parts in your unit. Using a part of lesser quality or substitute design may result in unit damage or personal injury.

7-3. WHEN ORDERING PARTS

Once the part you want to order has been found in the Part List, write down the following information:

1. From the exploded drawing and Parts List (Sample)

Item Number	8
Part Number	43768
Description	On/Off Switch

2. From the data plate (Sample)

Product Number	01400
Serial Number	00100
Voltage	208

7-4. PRICES

Your distributor has a price parts list and will be glad to inform you of the cost of yours parts order.

7-5. DELIVERY

Commonly replaced items are stocked by your independent Henny Penny distributor and will be sent out when your order is received. Other parts will be ordered by the distributor from Henny Penny Corporation. Normally, these will be sent to your distributor within three working days.

7-6. WARRANTY

All replacement parts (except lamps and fuses) are covered under warranty for 90 days against manufacturing defects and workmanship. If damage occurs during shipping, notify the carrier at once so that a claim may be properly filed. Refer to the warranty in this manual for other rights and limitations.

**7-7. RECOMMENDED
SPARE PARTS FOR
DISTRIBUTORS**

Recommended replacement parts, stocked by your distributor, are indicated with √ in the parts lists. Please use care when ordering recommended parts, because all voltages and variations are marked. Distributors should order parts based upon common voltages and equipment sold in their territory.

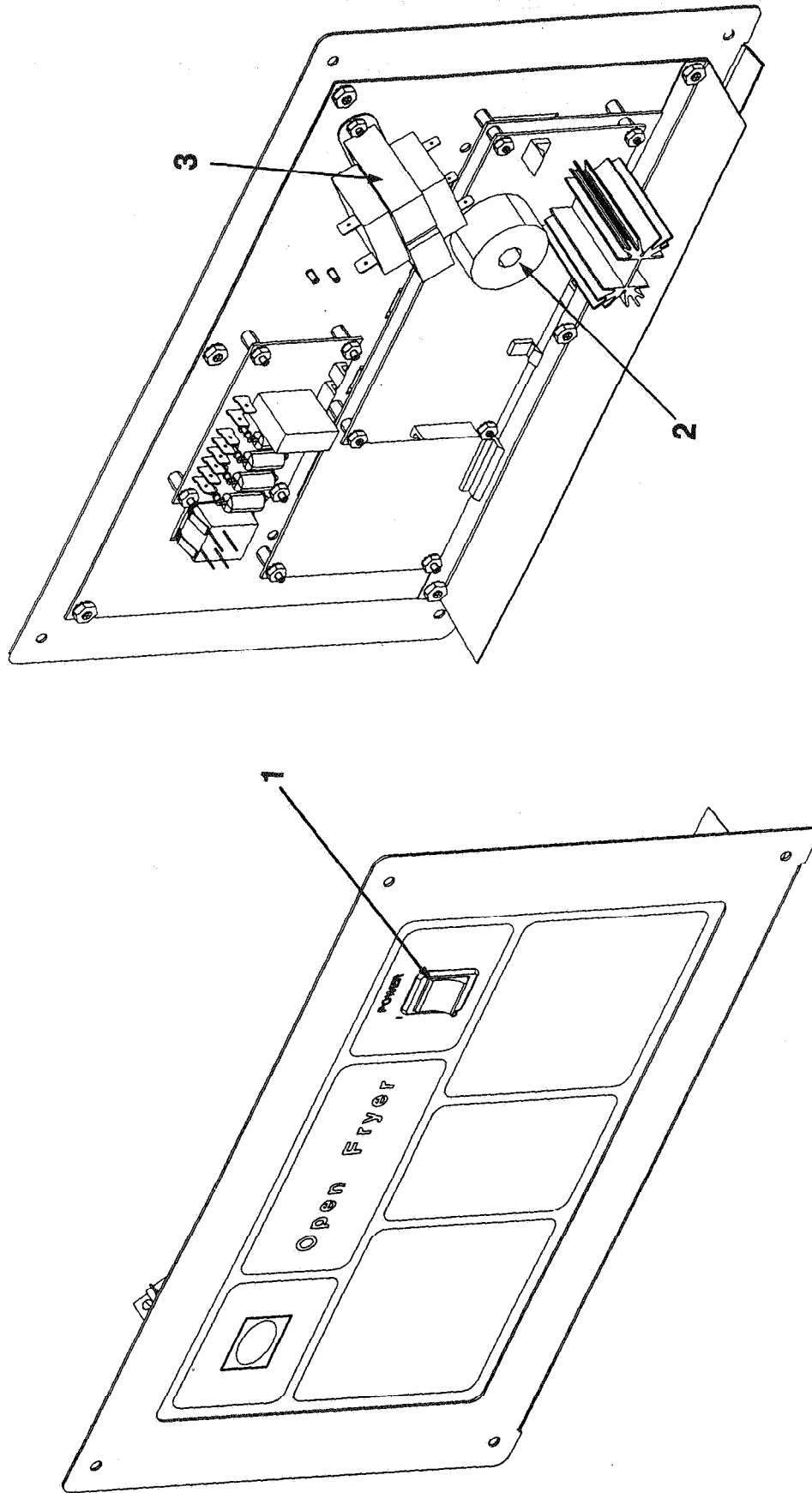

Figure 7-1. Control Panel Assembly - Complete

Control Panel Assembly - Complete

Item No.	Part Number	Description	Quantity per unit		
			303	302	301
7-1	33309	Control Panel Assembly Complete (Gas Models) - 120V	3	2	1
	33308	Control Panel Assembly Complete (Electric Models) - 208/240V	3	2	1
	44784	Control Panel Assembly Complete (Gas Models) - 240V	3	2	1
1	43768	Power (ON/OFF) Switch	3	2	1
2	40500	Replaceable Beeper	3	2	1
3	30978	Transformer - 120V-12V (Gas)	3	2	1
3	28979	Transformer - 208/240V-12V (Electric)	3	2	1

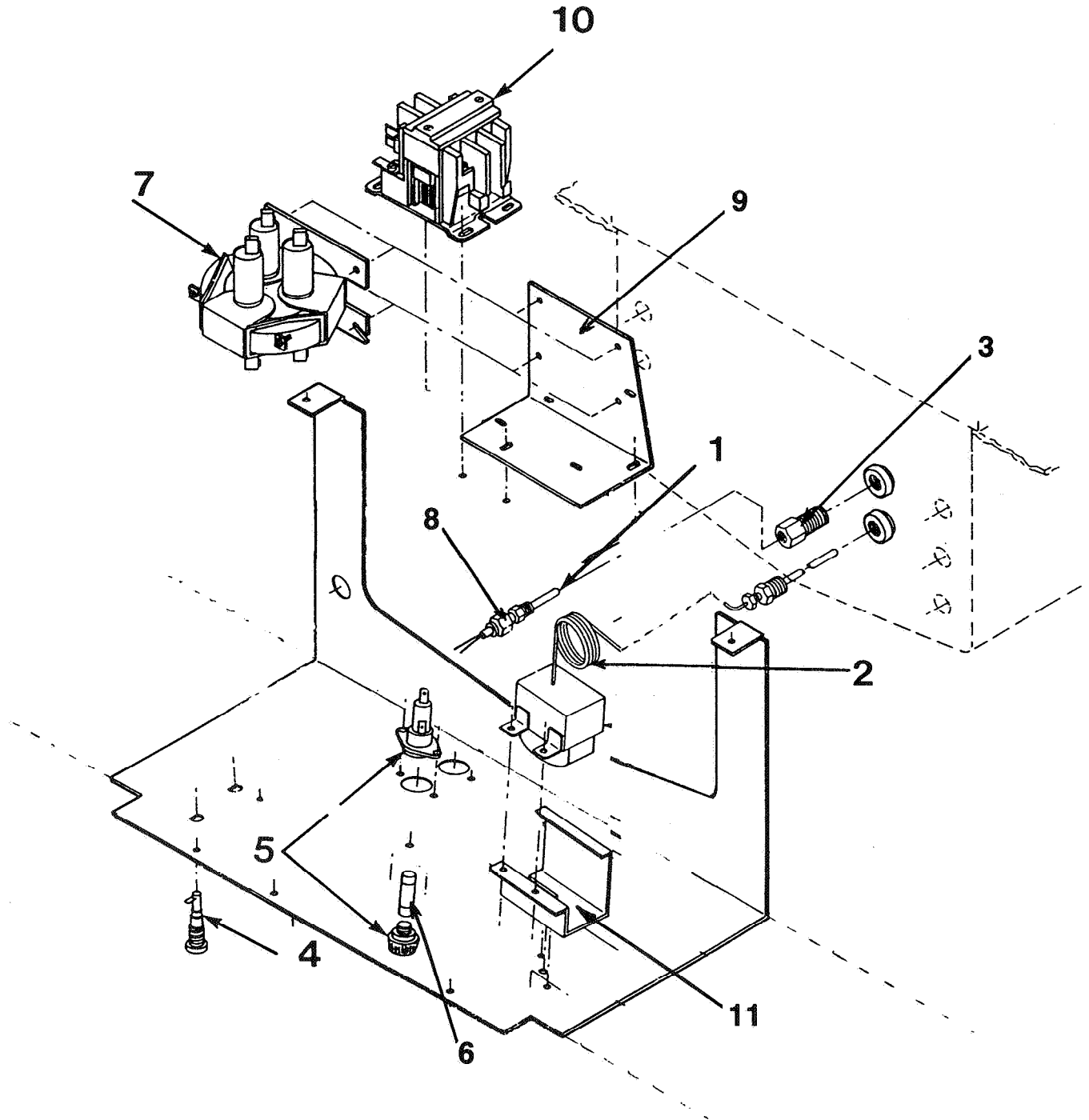
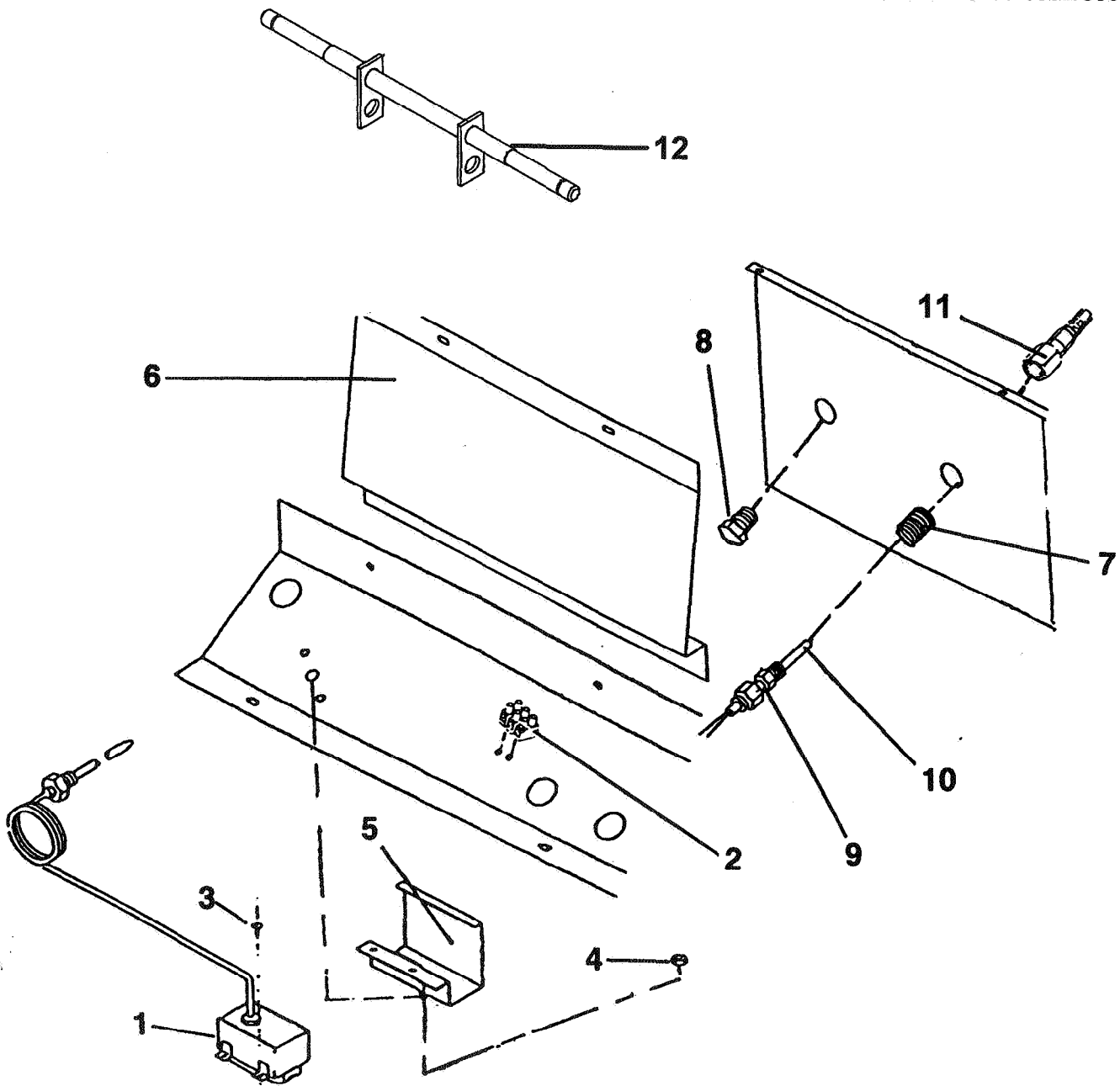

Figure 7-2. Electrical Components (Electric Models)

Electrical Components (Electric Models)

Item No.	Part Number	Description	Quantity per unit		
			303	302	301
7-2		Electrical Components (Electric Models)			
1	29523	Thermal Sensor (Probe)	3	2	1
2	16738	High Temperature Limit Control	3	2	1
3	33179	Thermocouple Pot Fitting	3	2	1
4	30090	Fuse Holder Assy. (5 amp)	6	4	2
5	EF02-006	Fuse Holder Assy. (15 amp)	6	4	2
5	EF02-104	Fuse Holder Assy. - CE	6	4	2
6	EF02-007	Fuse 15 amp.	6	4	2
6	EF02-105	Fuse 15 amp - CE	6	4	2
7	29942	Contactor - Mercury	3	2	1
8	30094	Compression Fitting	3	2	1
9	19682	Contactor Bracket	3	2	1
10	19405	Contactor	3	2	1
11	17216	High Limit Bracket	3	2	1
12	33376*	Insulation-Pot Front	3	2	1
13	29901*	Cap.-Resistor Assy.-Primary Contactor	3	2	1
14	51065*	EMC Filter Board Assy. (CE)	1	1	1
15	33498*	Cap.-Resistor Assy.-Heat Contactor	3	2	1
16	36012*	Cap.-Resistor Assy.-Pump Motor	1	1	1

*not shown



NOTE: Use PST Pipe Sealant around pipe fittings, compression fitting, and High Temperature Limit Control.

Figure 7-3. Thermal Sensor and High Temperature Limit Control (Gas Model)

Thermal Sensor and High Temperature Limit Control (Gas Models)

Item No.	Part Number	Description	Quantity per unit		
			303	302	301
7- 3		Thermal Sensor and High Temperature Limit Control (Gas Models)			
√ 1	16738	High Temperature Limit Control	3	2	1
√ 1	14267	High Temp. Limit Control Kit- CE - Electronic	3	2	1
√ 1	14282	High Temp. Limit Control Kit - CE - Electro-mech.	3	2	1
2	33068	Terminal Block	3	2	1
3	SC02-018	Screw, Thread Forming #8	6	4	2
4	NS02-001	Nut, #10-32 Hex Keys	3	2	1
6	33132	Control Shroud Access Plate	3	2	1
7	FP01-024	Bushing - 3/8-1/8"	3	2	1
8	FP01-099	Pipe Plug	3	2	1
9	33094	Compression Fitting	3	2	1
5	17216	High Limit Control Bracket	3	2	1
√ 10	55168	Thermal Sensor - 6"	3	2	1
√ 10	55167	Thermal Sensor - 3"	3	2	1
√ 10	34822	Thermal Sensor - 6" - CE	3	2	1
11	51071	Thermocouple Pot Fitting	3	2	1
12	34813	Capillary Bulb Mounting Assy.	3	2	1
12	50698	Clamp-Rear, Capillary Bulb - CE (not shown)	3	2	1
12	50699	Clamp-Front, Capillary Bulb - CE (not shown)	3	2	1
13	44371	Seal Weld Assy. (not shown)	2	2	2
√ 14	36012	Capacitor - Resistor Assy. (not shown)	7	5	3
15	33304	Insulation - Front Cover	1	1	1

√ recommended parts

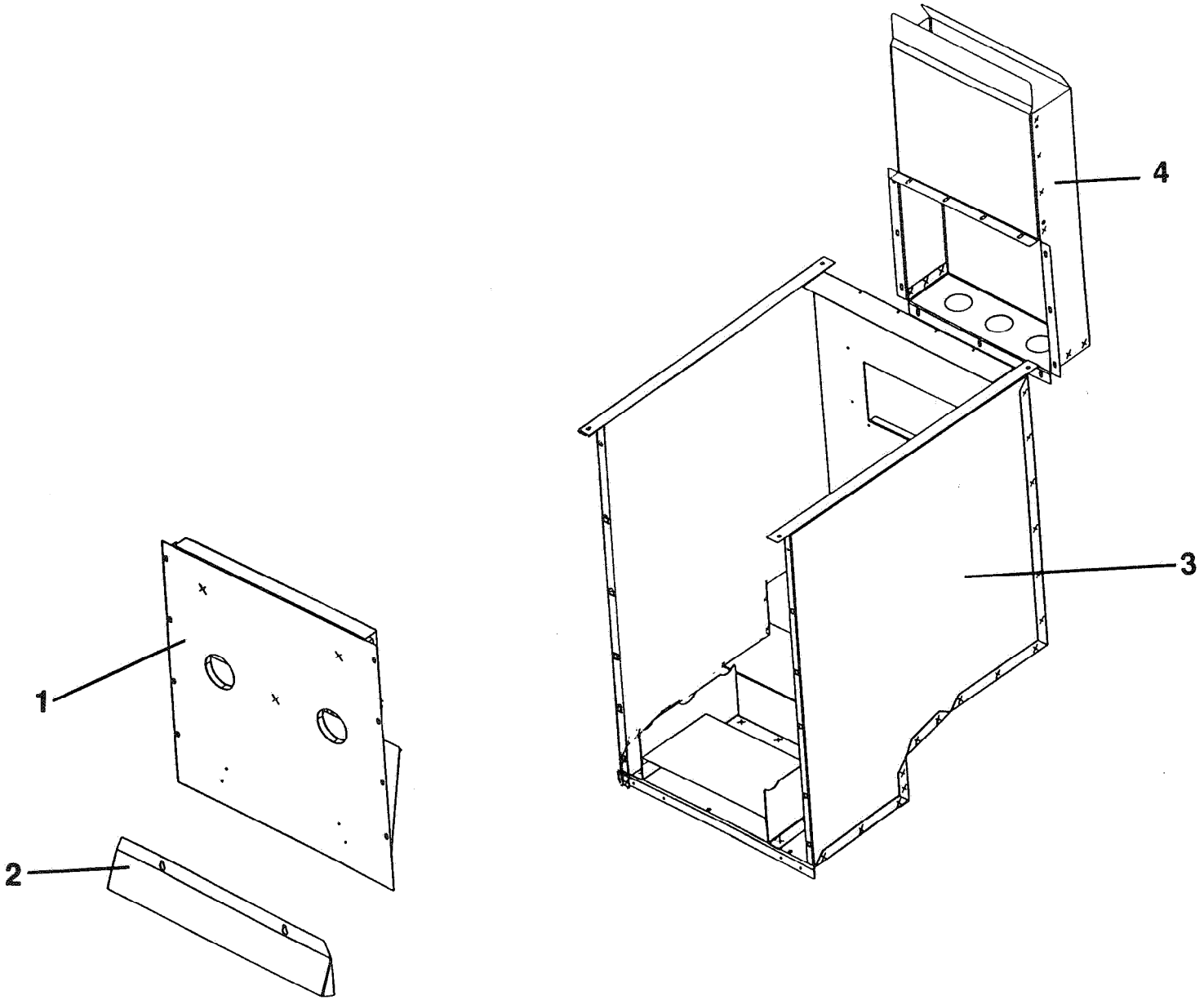

Figure 7-4. Firebox and Flue Assembly (Gas Model)

Firebox and Flue Assembly (Gas Models)

Item No.	Part Number	Description	Quantity per unit		
			303	302	301
7-4		Firebox and Flue Assembly (Gas Models)			
1	33166	Firebox Front Cover Assy.	3	2	1
2	16406	Heat Shield	3	2	1
3	33164	Outer Firebox Weld Assy.	3	2	1
4	33162	Flue Assy.	3	2	1
5	55328	Firebox Assy. - CE - OG-301	-	-	1

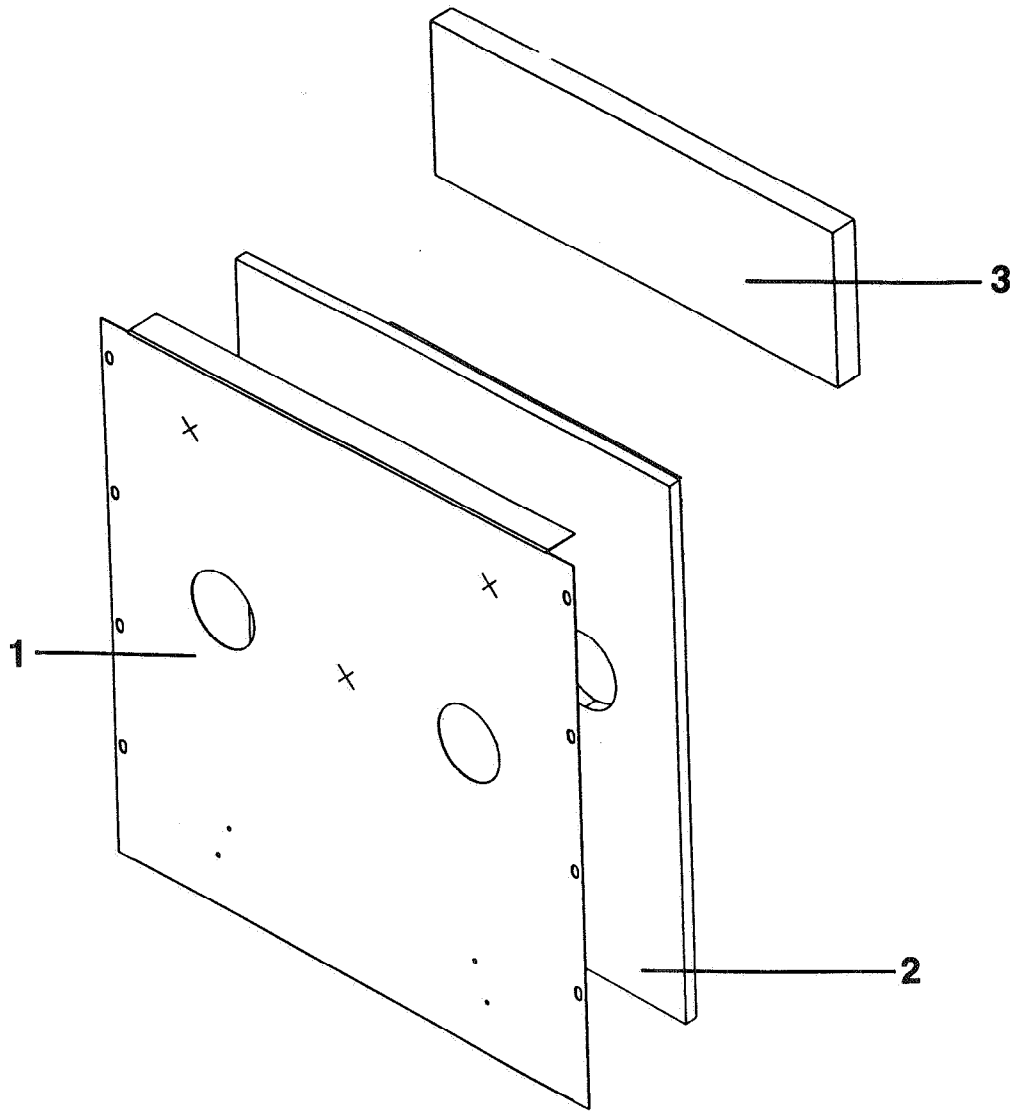

Figure 7-5. Outer Front Firebox Assy. (Gas Model)

Outer Front Firebox Assembly (Gas Model)

Item No.	Part Number	Description	Quantity per unit		
			303	302	301
7-5		Outer Front Firebox Assy. (Gas Model)			
1	33165	Outer Front Weld Assy.	3	2	1
2	33047	Insulation-Front Firebox	3	2	1
3	33335	Insulation-Top Front	3	2	1

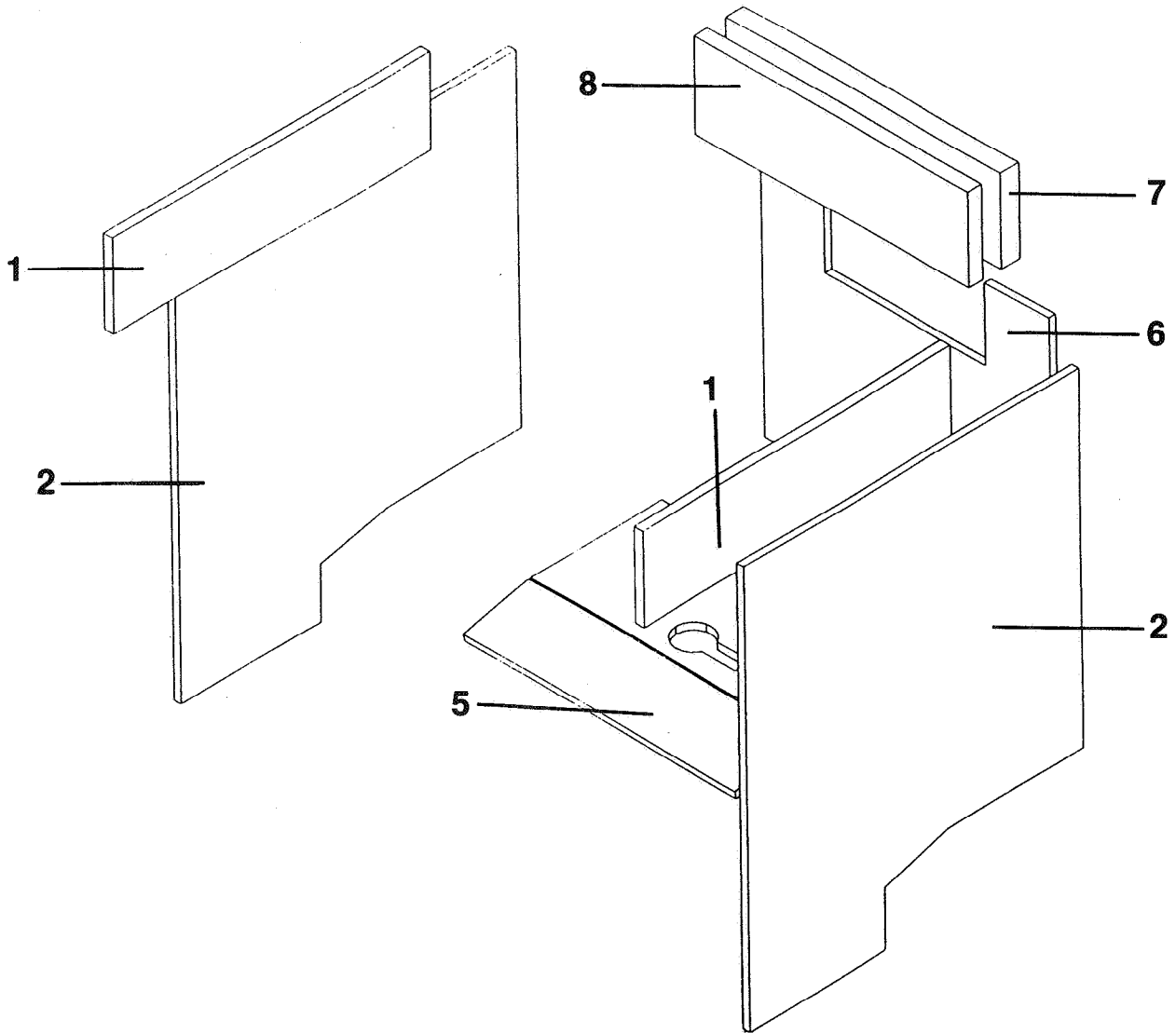

Figure 7-6. Firebox Insulation Assembly (Gas Model)

Firebox Insulation Assembly (Gas Model)

Item No.	Part Number	Description	Quantity per unit		
			303	302	301
7-6		Firebox Insulation Assembly (Gas Model)			
1	33348	Insulation-Top/Sides	6	4	2
2	33046	Insulation-Firebox Sides	6	4	2
2	55327	Insulation-Firebox sides - CE - OG-301	2	2	1
5	16503	Insulation-Bottom Panel	3	2	1
6	16502	Insulation-Back Panel	3	2	1
7	33346	Insulation-1 in.-Top/Rear	3	2	1
8	33456	Insulation-3/4 in.-Top/Rear	3	2	1
9	55326	Insulation-Firebox to Frame - CE (not shown)	2	2	1

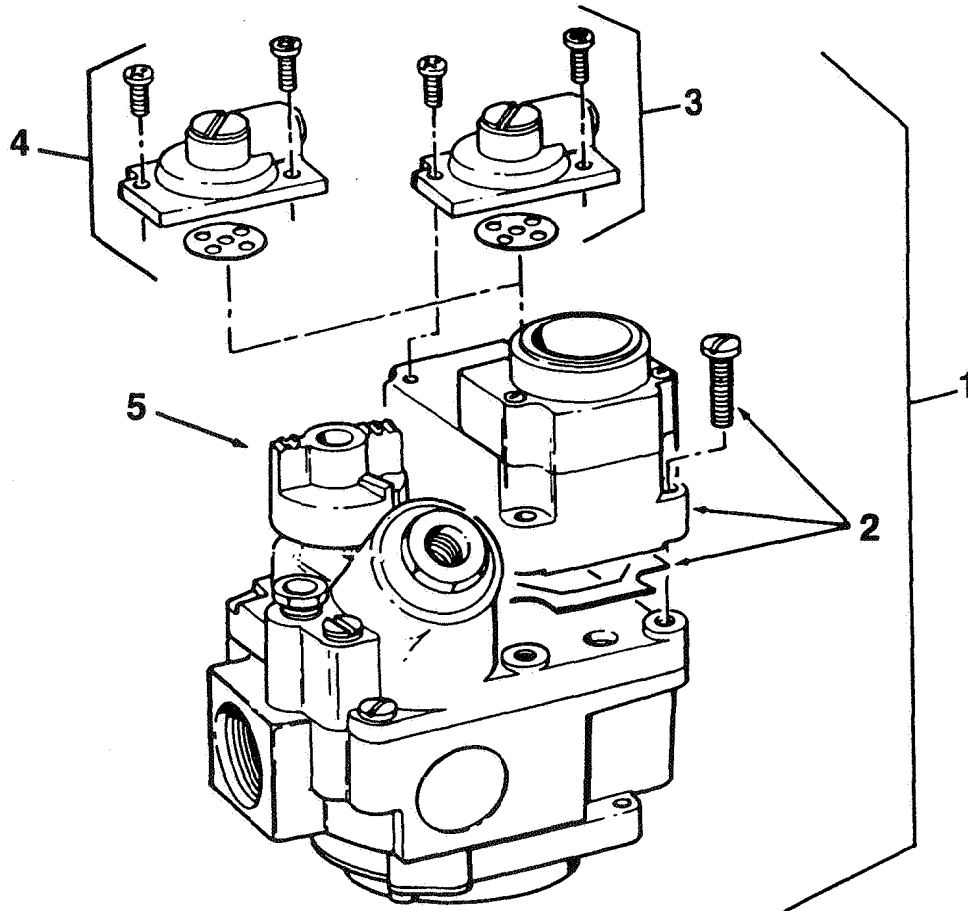

Figure 7-7. Gas Control Valve (Gas Model)

Gas Control Valve (Gas Model)

Item No.	Part Number	Description	Quantity per unit		
			303	302	301
7-7		Gas Control Valve (Gas Model)			
1a	16216	Valve, Control, Natural Gas, 120 Volt	3	2	1
1b	16217	Valve, Control, Propane Gas, 120 Volt	3	2	1
1A	16380	Valve, Control, Natural Gas, 208-240 Volt	3	2	1
1B	16381	Valve, Control, Propane Gas, 208-240 Volt	3	2	1
2a	16254	Operator, Gas Valve, 120 Volt, Natural	3	2	1
2A	16710	Operator, Gas Valve, 208-240 Volt, Natural	3	2	1
2b	16386	Operator, Gas Valve, 120 Volt, Propane	3	2	1
2B	16384	Operator, Gas Valve, 208-240 Volt, Propane	3	2	1
3	16253	Regulator, Gas Valve, Natural Gas	3	2	1
4	16352	Regulator, Gas Valve, Propane Gas	3	2	1
5	16267	Dial, Gas Cock	3	2	1

NOTE: 1a consists of 2a, 3, and 5
 1A consists of 2A, 3, and 5
 1b consists of 2b, 4, and 5
 1B consists of 2B, 4 and 5

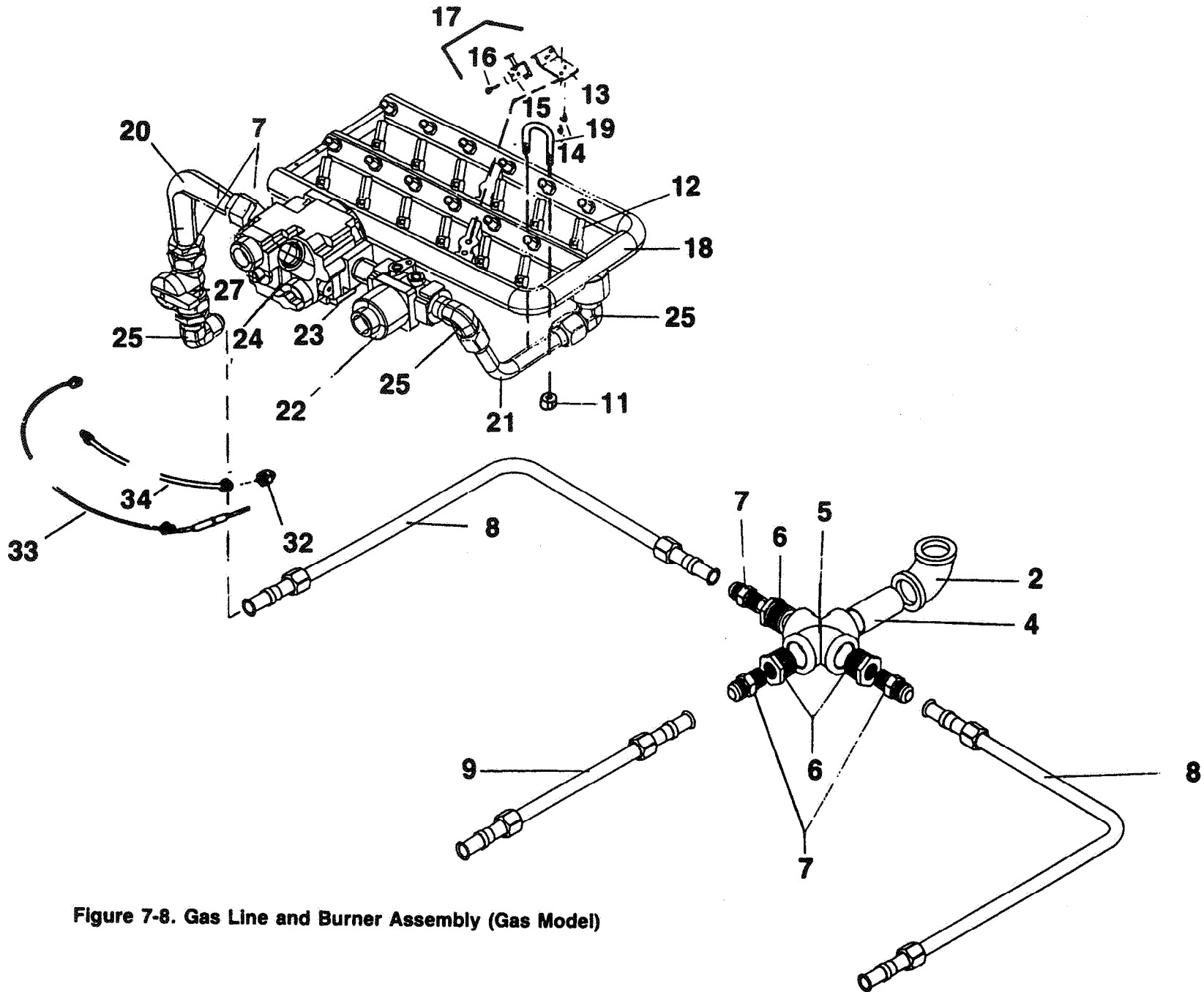

Figure 7-8. Gas Line and Burner Assembly (Gas Model)

Gas Line and Burner Assy. (Gas Model)

Item No.	Part Number	Description	Quantity per unit		
			303	302	301
7-8		Gas Line and Burner Assy. (Gas Model)			
2	FP01-093	Elbow - 1 in. NPT x 90 Female BI	1	-	-
4	FP01-108	Nipple - Pipe 1"x 8" BI	1	-	-
5	FP01-092	Cross Tee - 1 in. NPT Female BI	1	-	-
6	FP01-085	Bushing - Reducing 1 in. to 1/2 BLK	3	-	-
7	16335	Male Connector 37 Flare	5	-	-
8	33325	Assy. - Gas Line	2	-	-
8	33489	Assy. - Gas Line - Left - 303 DS	1	-	-
8	33835	Assy. - Gas Line - Right - 303 DS	1	-	-
9	45621	Assy. - Middle Gas Line	1	-	-
11	NS02-002	Nut - Keps - 1/4-20 C	6	4	-
12	17013-1	SET, Orifice, Natural Gas	3	2	1
12	16561-1	Orifice, Nat. Gas - S.S.	3	2	1
12	16562-1	Orifice, Nat. Gas - Brass	69	46	23
12	17013-3	SET, Orifice, Propane Gas	3	2	1
12	16561-3	Orifice, Propane Gas - S.S.	3	2	1
12	16562-3	Orifice, Propane Gas - Brass	69	46	23
13	29969	Bracket, Pilot Holder	3	2	1
14	SC01-009	Screw, Pilot Holder Bracket	3	2	1
15	29823	Pilot & Orifice Assembly	3	2	1
16	SC01-006	Screw, Pilot Holder	3	2	1
17	30913	Pilot & Bracket Assy. - Nat.	3	2	1
17	30904	Pilot & Bracket	3	2	1
18	16205	Casting, Burner	3	2	1
19	SC06-013	U-Bolt, Gas Line	3	2	1
20	45393	Gas Valve Supply Tube	3	2	1
21	38464	Gas Burner to Control Line Assy.	3	2	1
√ 22	38446	Solenoid - Gas	3	2	1
√ 22	38467	Solenoid - Gas - 240V	3	2	1
√ 23	FP01-035	Nipple - Close	3	2	1
√ 22	34801	Solenoid - Gas - 240V - CE	3	2	1
√ 22	34801	Solenoid - Gas - 240V - CE	3	2	1
√ 24	16216	Valve - Nat. Gas Valve	3	2	1
√ 24	16217	Valve - Propane Gas Valve	3	2	1
√ 24	16380	Valve - Nat. Gas Valve - 240V	3	2	1
√ 24	16381	Valve - Propane Gas Valve - 240V	3	2	1
√ 24	34804	Valve - Nat. Gas Valve - 240V - CE	3	2	1
√ 24	34803	Valve - Propane Gas Valve - 240V - CE	3	2	1
25	16336	Elbow - 1/2 NPT x 90 Female BI	9	6	3
27	33178	Valve - 3/4 in. Gas Ball	3	2	1
27	45401	Valve - 1/2 in. Gas Ball	3	2	1
32	29820	Orifice - Pilot - Nat. Gas	3	2	1
32	32407	Orifice - Pilot - Propane Gas	3	2	1
√ 33	16219	Thermocouple	3	2	1
√ 33	34820	Thermocouple - CE	3	2	1
34	16218	Tube - Pilot Assy.	3	2	1
35*	33167	Gas Line Assembly - w/ Swivel	1	-	-
36*	FP01-014	1/8 in. Elbow - Gas Check Port	3	2	1
37*	45484	Gas Line Assy. - OG-301	-	-	1

√ recommended parts/*not shown

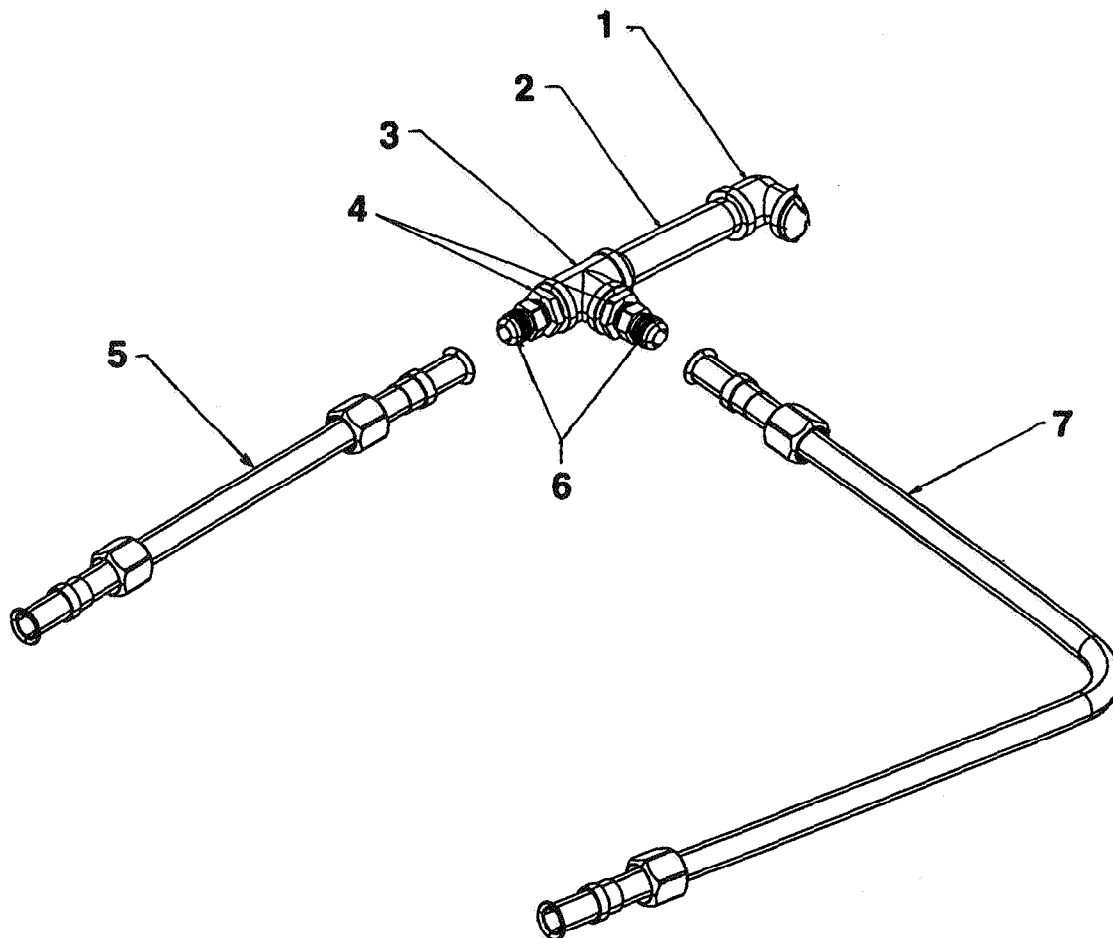

Figure 7-8A. Gas Line Assembly — OG-302

Gas Line Assembly — OG-302

Item No.	Part Number	Description	Qty. per unit	
			303	302
1	FP01-098	Elbow - 3/4 NPT x 90 Female BI		1
2	FP01-109	Nipple - 3/4 x 10 LG BI		1
3	FP01-097	Tee - 3/4 NPT Female Pipe BI		1
4	FP01-089	Bushing - Reducing 3/4 M to 1/2 F BL		2
5	33489	Assy. - Left Gas Line		1
6	16335	Male Connector 37 Flare		2
7	33490	Assy. - Right Gas Line		1
8	33501	Gas Line Assy. w/Swivel (not shown)		1

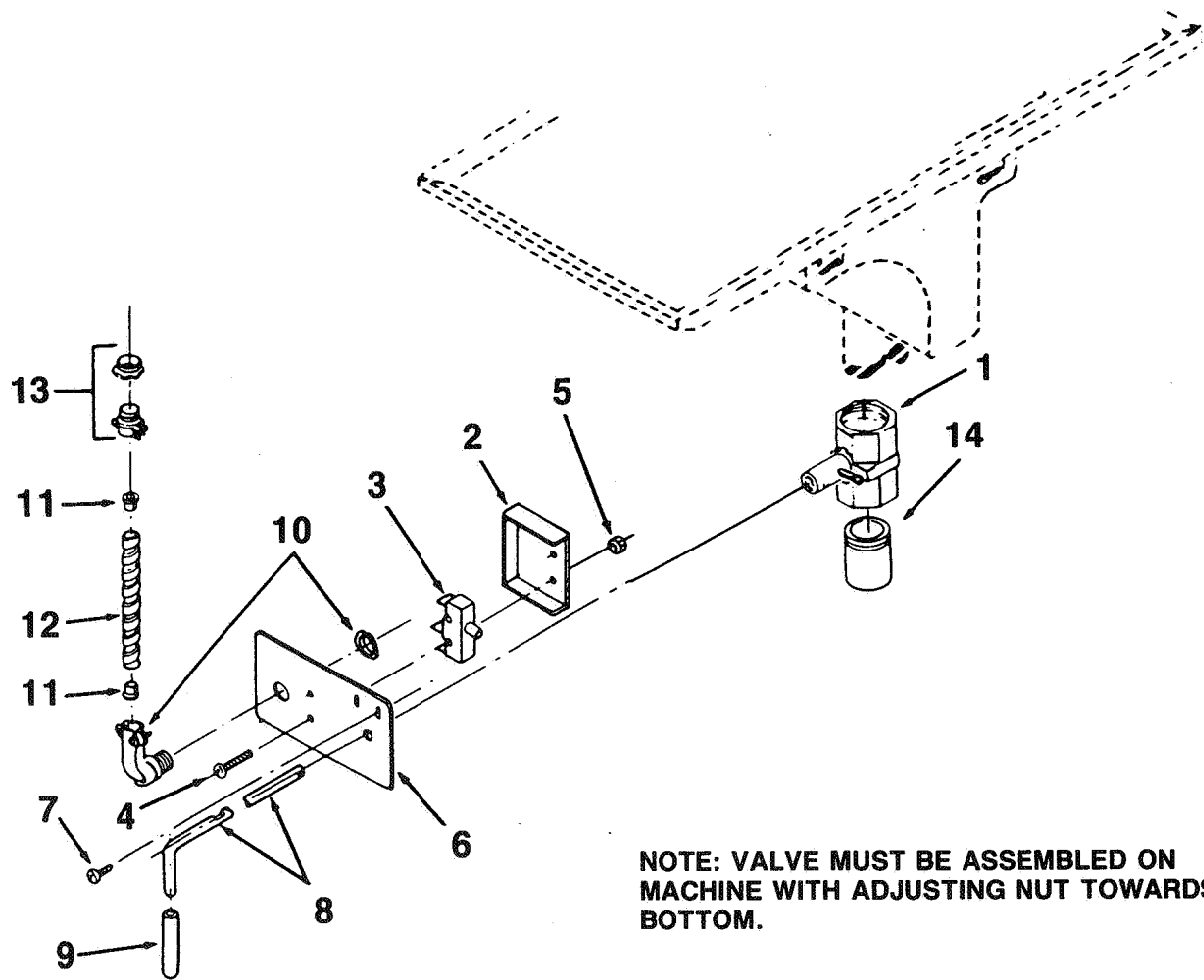
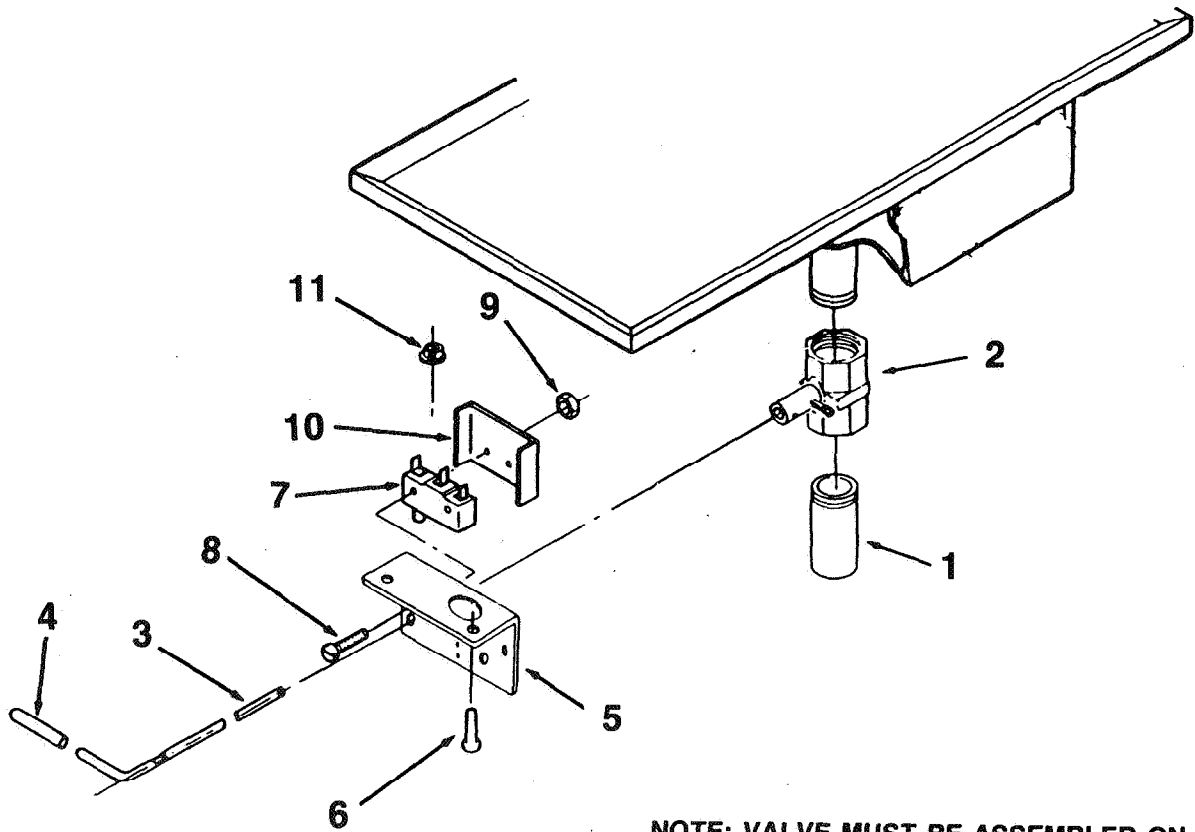

Figure 7-9. Drain Valve Assembly (Gas Model)

Drain Valve Assembly (Gas Model)

Item No.	Part Number	Description	Quantity per unit		
			303	302	301
7-9		Drain Valve Assembly (Gas Model)			
1	17260	Body Assembly, Drain Valve	3	2	1
2	17210	Cover, Microswitch	3	2	1
√ 3	18227	Microswitch	3	2	1
4	SC01-058	Screw, Microswitch	6	4	2
5	NS02-005	Nut, Microswitch	6	4	2
6	33334	Bracket, Drain, Valve Rod	3	2	1
7	SC03-005	Screw, Drain Bracket	6	4	2
8	17254	Rod, Drain Valve	3	2	1
8	55369	Rod, Drain Valve - OG-302 (SN: EN006IH and above)	-	2	-
9	16293	Cover, Valve Handle	3	2	1
10	18644	Connector, 901 Flexible Conduit (Includes Nut)	3	2	1
11	18105	Insulator	6	4	2
12	33203	Conduit, Flexible	3	2	1
13	18111	Connector, Flexible Conduit (Includes Nut)	3	2	1
14	33355	Extension Nipple	3	2	1
14	45395	Extension Nipple w/ Splash Guard (not shown)	3	2	1
√ 15	14652	Kit - OG30X - Normally Open Drain Switch	3	2	1

√ recommended parts



NOTE: VALVE MUST BE ASSEMBLED ON MACHINE WITH ADJUSTING NUT TOWARDS BOTTOM.

Figure 7-10. Drain Valve Assembly (Electric Model)

Drain Valve Assembly (Electric Model)

Item No.	Part Number	Description	Quantity per unit		
			303	302	301
7-10		Drain Valve Assembly (Electric Model)			
1	33302	Nipple, Drain Extension	3	2	1
1	45396	Nipple, Drain Extension w/ Splash Guard (not shown)	3	2	1
2	17260	Body, Drain Valve	3	2	1
3	18818	Rod, Drain Valve Extension	3	2	1
4	16293	Cover, Valve Handle	3	2	1
5	33311	Bracket, Drain Valve	3	2	1
6	SC03-005	Screw, Drain Valve Bracket	6	4	2
7	18227	Microswitch	3	2	1
8	SC01-058	Screw, Microswitch	6	4	2
9	NS02-005	Nut, Microswitch	6	4	2
10	18528	Cover, Microswitch	3	2	1
11	EF02-004	Bushing, Snap	3	2	1

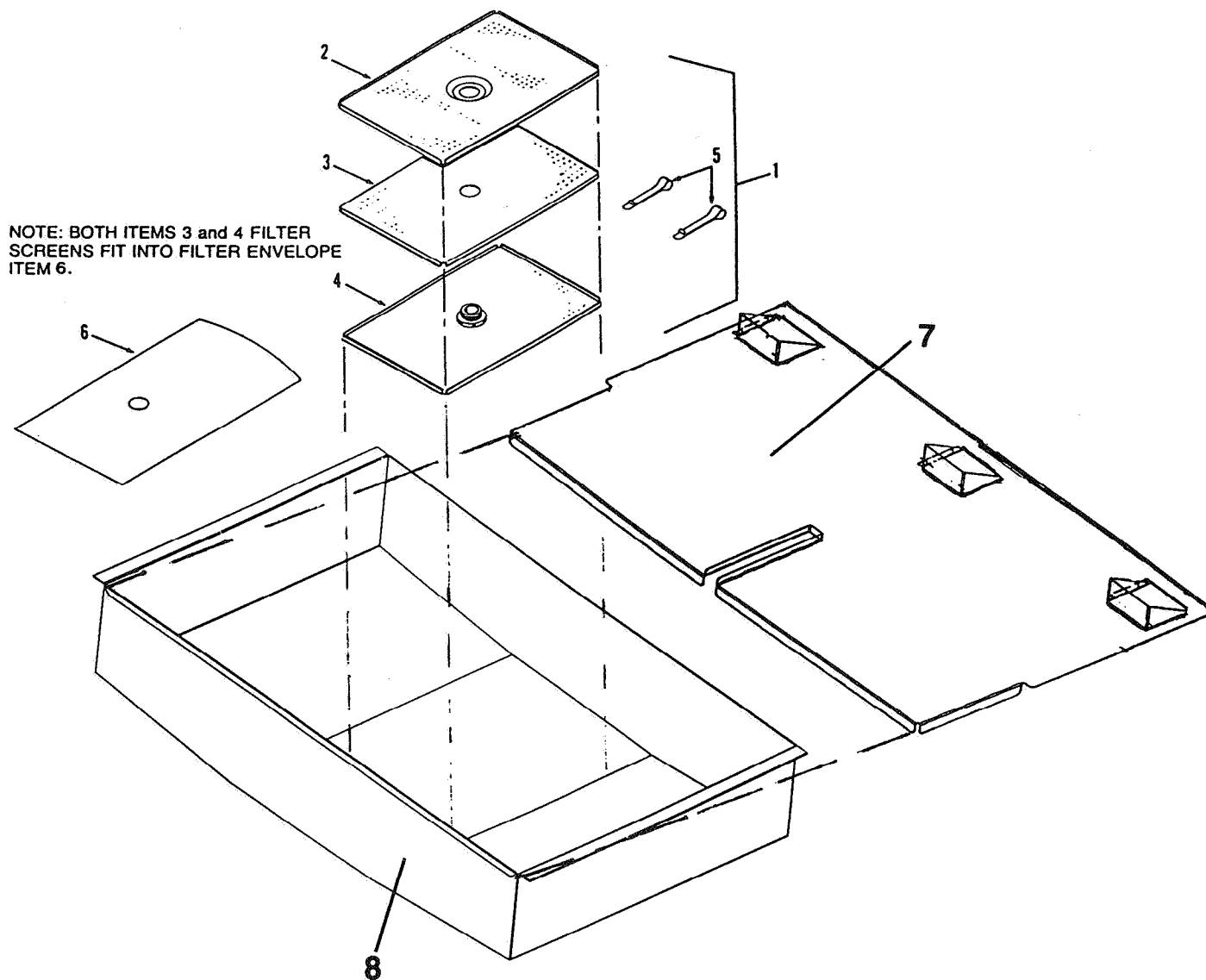

NOTE: BOTH ITEMS 3 and 4 FILTER SCREENS FIT INTO FILTER ENVELOPE ITEM 6.

Figure 7-11. Drain Pan and Filter Screen Assy. (Gas and Electric Models)

Drain Pan and Filter Screen Assembly (Gas and Electric Models)

Item No.	Part Number	Description	Quantity per unit		
			303	302	301
7-11		Drain Pan and Filter Screen Assy. (Gas and Electric Models)			
1	17510	Screen Assembly, Filter	1	1	1
2	17501	Catcher Crumb	1	1	1
3	17502	Screen, Top Filter	1	1	1
4	17503	Screen, Bottom Filter	1	1	1
5	17505	Clips, Filter Envelope	2	2	2
√ 6	12102	Filter, Envelope Paper (100 per Carton)	1	1	1
7	33256	Cover, Drain Pan Assy. - OG-303 SN: GN015IE & below	1	-	-
7	33257	Cover, Drain Pan Assy. - OE-303 SN: GM003IE & below	1	-	-
7	33455	Cover, Drain Pan Assy. - OG-302 SN: GN015IE & below	-	1	-
7	33454	Cover, Drain Pan Assy. - OE-302 SN: GM003IE & below	-	1	-
7	33763	Cover, Drain Pan Assy. - OE-301 SN: GN015IE & below	-	-	1
7	33762	Cover, Drain Pan Assy. - OG-301 SN: GM003IE & below	-	-	1
7	45437	Cover, Drain Pan Assy. - OG-303 SN: GN016IE & above	1	-	-
7	45442	Cover, Drain Pan Assy. - OE-303 SN: GM004IE & above	1	-	-
7	55377	Cover, Drain Pan Assy. - OG-302 SN: HN001IH & above	-	1	-
7	45427	Cover, Drain Pan Assy. - OG-302 SN: GN016IE to HN001IH	-	1	-
7	55375	Cover, Drain Pan Assy. - OE-302 SN: HM001IH & above	-	1	-
7	45436	Cover, Drain Pan Assy. - OE-302 SN: GM004IE to HM001IH	-	1	-
7	45516	Cover, Drain Pan Assy. - OE-301 SN: GM004IE & above	-	-	1
7	45443	Cover, Drain Pan Assy. - OG-301 SN: GN016IE & above	-	-	1
8	33248	Drain Pan - OG/OE-303	1	-	-
8	55373	Drain Pan - OG/OE-302	-	1	-
8	33749	Drain Pan - OG/OE-301	-	-	1
9	45386	Pan Latch Assy. (not shown)	1	1	1
10	45384	Pan Stop (not shown)	2	2	1

√ recommended parts

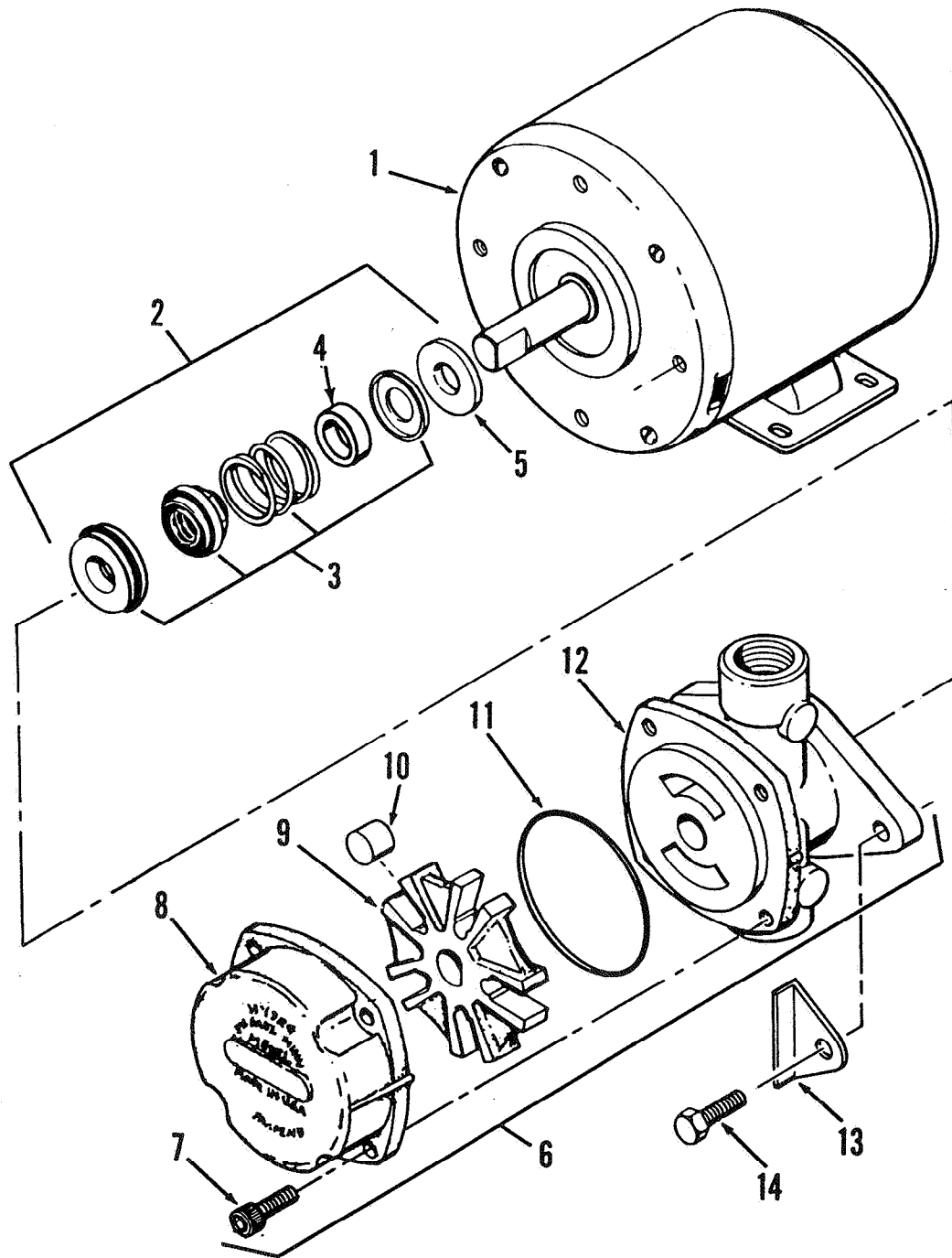

Figure 7-12. Roller Pump (Gas and Electric Models)

Roller Pump (Gas and Electric Models)

Item No.	Part Number	Description	Quantity per unit		
			303	302	301
7-12		Roller Pump (Gas and Electric Models)			
1	18628	Motor, 50/60 Hz	1	1	1
2	17476	Seal Kit	1	1	1
3	17445	Seal, Mechanical, Viton	1	1	1
4	17460	Spacer, Pump Filter	1	1	1
5	17457	Washer, Motor Shaft	1	1	1
6	17437	Pump Assembly	1	1	1
7	17452	Screw, Pump Cover	4	4	4
8	17451	Cover, Pump	1	1	1
9	17447	Rotor, Pump	1	1	1
10	17446	Roller, Pump	5	5	5
11	17453	O'Ring, Pump	1	1	1
12	17454	Body, Pump	1	1	1
13	17456	Shield, Pump	2	2	2
14	SC01-026	Screw, Pump Shield	2	2	2

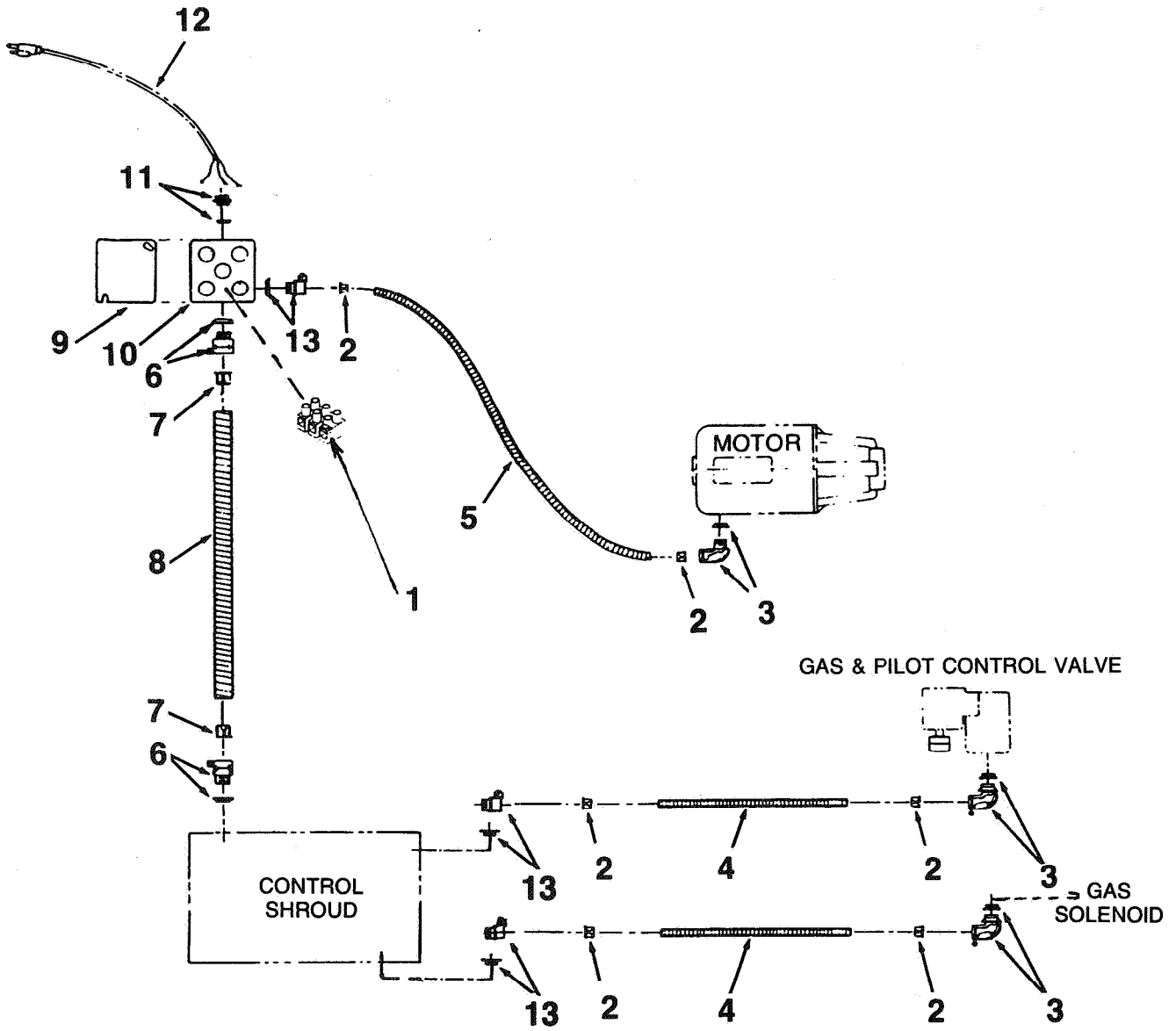

Figure 7-13. Electric Conduit Assembly (Gas Model)

Electric Conduit Assembly (Gas Model)

Item No.	Part Number	Description	Quantity per unit		
			303	302	301
7- 13		Electric Conduit Assembly (Gas Model)			
1	ME50-021	Terminal Block	1	1	1
2	18105	Bushing, Antishort	14	10	6
3	18107	Connector, Conduit	7	5	3
4	17221	Conduit, Flexible	6	4	2
5	33224	Conduit, Flexible	1	1	1
6	18104	Connector, Conduit	2	2	2
7	18105	Bushing, Antishort	2	2	2
8	33228	Conduit, Flexible	1	1	1
9	18101	Cover, Junction Box	1	1	1
9	54944	Cover, Junction Box - CE	1	1	1
10	18102	Box, Junction	1	1	1
10	54965	Box, Junction - CE	1	1	1
11	18103	Connector, Electric Cord	1	1	1
12	33353	Power Cord, Coiled	1	1	1
12	17902	Power Cord - Straight	1	1	1
12	55372	Power Cord - 220-240 volt	1	1	1
13	18644	Conduit Connector	7	5	3

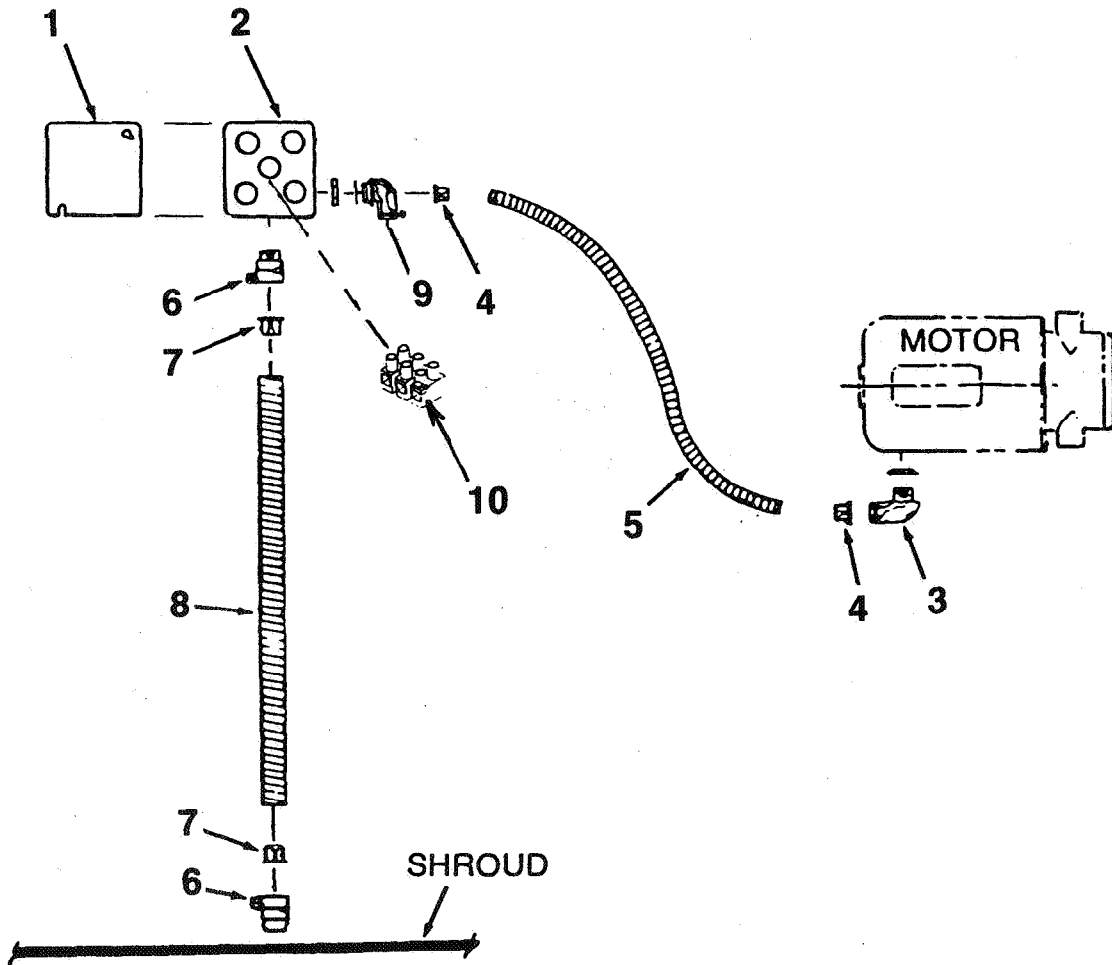

Figure 7-14. Electric Conduit Assembly (Electric Model)

Electric Conduit Assembly (Electric Model)

Item No.	Part Number	Description	Quantity per unit		
			303	302	301
7-14		Electric Conduit Assembly (Electric Model)			
1	19708	Cover, Junction Box	3	2	1
2	19707	Box, Junction	3	2	1
3	18107	Connector, Flexible Conduit	1	1	1
4	18105	Bushing, Antishort	2	2	2
5	33182	Conduit, Flexible	1	1	1
6	EF02-081	Connector, Flexible Conduit	6	4	2
7	EF02-088	Bushing, Antishort	6	4	2
8	33447	Conduit, Flexible	3	2	1
9	18644	Connector, Flexible Conduit - 90°	1	1	1
10	18146	Terminal Block	3	2	1

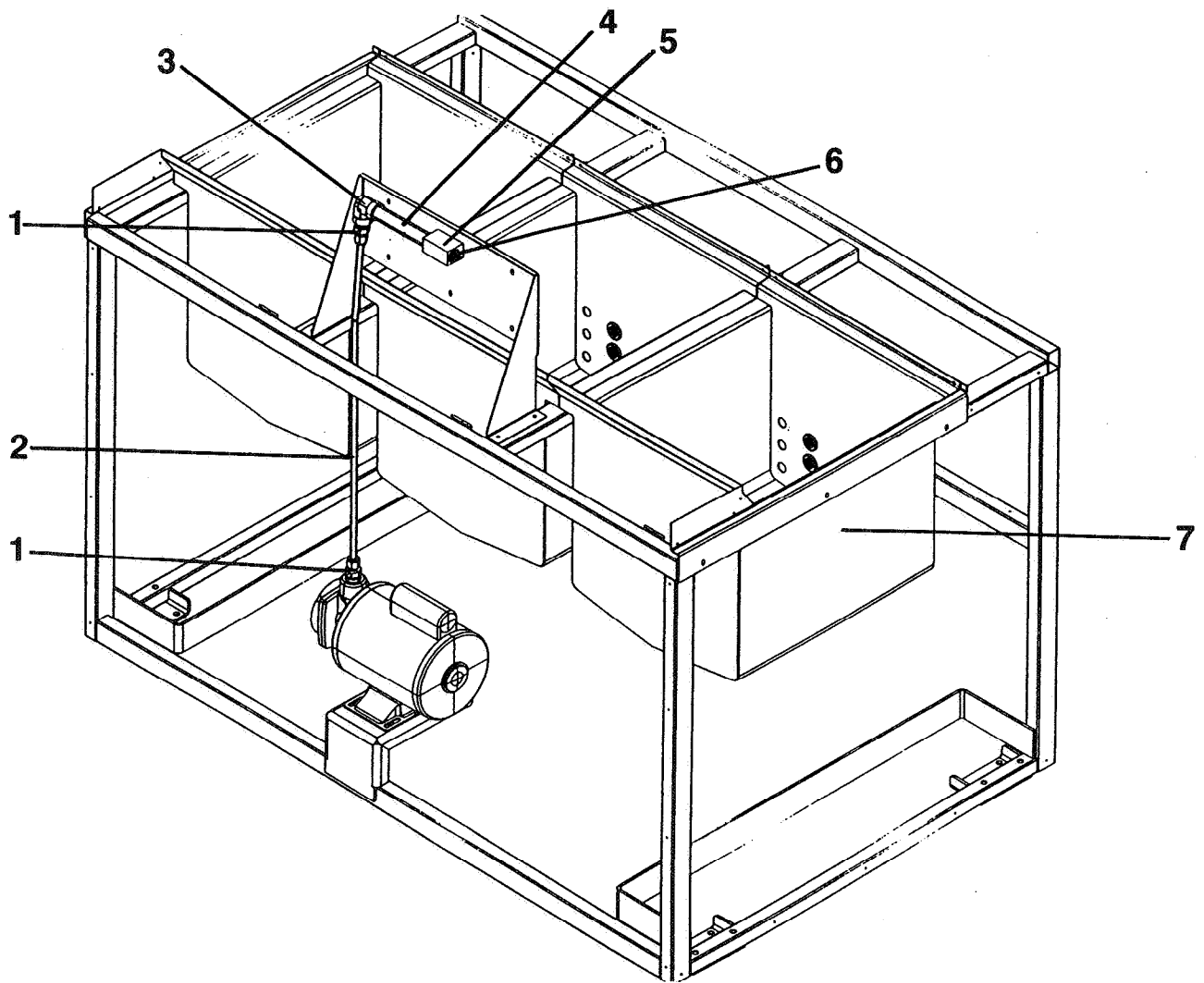

Figure 7-15. Cookpot and Return Line Assemblies (Gas and Electric Models)

Cookpot and Return Line Assemblies (Gas and Electric Models)

Item No.	Part Number	Description	Quantity per unit		
			303	302	301
7-15		Cookpot and Return Line Assemblies (Gas and Electric Models)			
1	FP01-082	Male Connector	2	2	2
2	48019	Return Line - 301 & 303	1	-	1
2	48018	Return Line - 302	-	1	3
3	FP01-096	Elbow	1	1	1
4	33106	Return Line - Upper	1	1	1
5	33066	Fitting - Return Line, Swivel	1	1	1
6	FP01-004	Pipe Plug	1	1	1
7	33771	Pot & Countertop Assy. - OE-301	-	-	1
7	54966	Pot & Countertop Assy. - OG-301	-	-	1
7	33459	Pot & Countertop Assy. - OE-302	-	1	-
7	54967	Pot & Countertop Assy. - OG-302	-	1	-
7	33089	Pot & Countertop Assy. - OE-303	1	-	-
7	54968	Pot & Countertop Assy. - OG-303	1	-	-
7	48453	Pot & Countertop Assy. - OG-303 DS	1	-	-

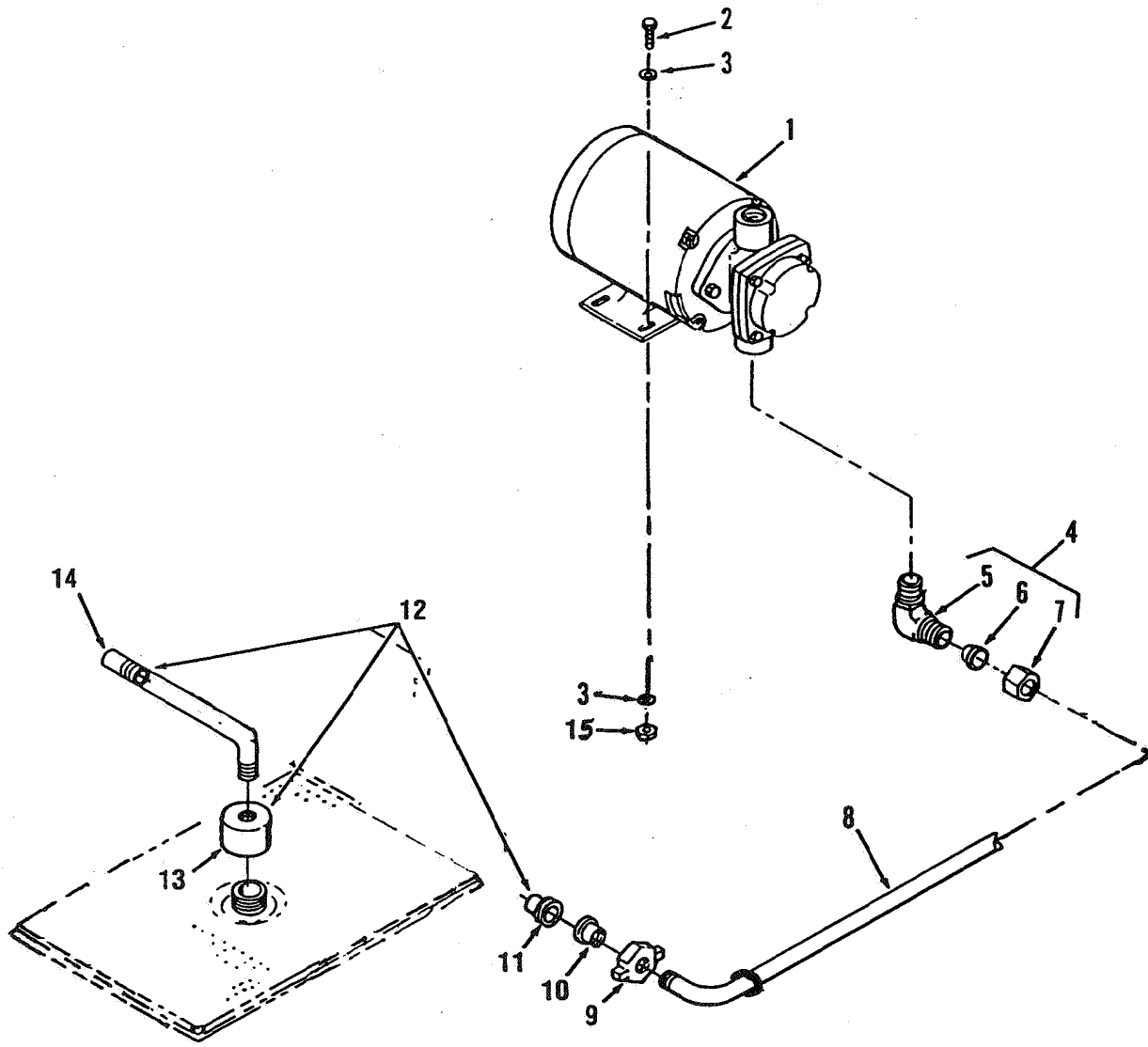

Figure 7-16. Lower Filter Plumbing Components (Gas and Electric Models)

Lower Filter Plumbing Components (Gas and Electric Models)

Item No.	Part Number	Description	Quantity per unit		
			303	302	301
7-16		Lower Filter Plumbing Component (Gas and Electric Models)			
1	67589	Motor and Pump, Filter	1	1	1
√	67583	Motor, Filter - 1/2 HP	1	1	1
	17437	Pump, Filter	1	1	1
√	17476	Pump Seal Kit	1	1	1
2	SC01-022	Screw, Motor	4	4	4
3	WA01-002	Washer	4	4	4
4	17424	Connector, Assembly, Male Elbow	1	1	1
5	17407	Connector, Male Elbow	1	1	1
6	16808	Fitting, Sleeve	1	1	1
7	16809	Nut, Fitting	1	1	1
8	33340	Tubing, Stainless Steel	1	1	1
9	17432	Fitting, Union Handle	1	1	1
√ 10	17431(use 69289)	Fitting, Male Union	1	1	1
√ 11	17430(use 69289)	Fitting, Female Union	1	1	1
12	17433	Standpipe Assembly, Filter	1	1	1
13	17403	Nut, Filter Screen	1	1	1
14	55367	Tubing, Stainless Steel	1	1	1
15	NS01-012	Nut, Motor	4	4	4
16*	FP01-106	Elbow - 5/8" Tube - 1/2 NPT - Male (OE/OG-301)	-	-	1
17	19811	1/2"-90, Street Elbow - S.S. (OE/OG-301)	-	-	1

√ recommended parts

*not shown

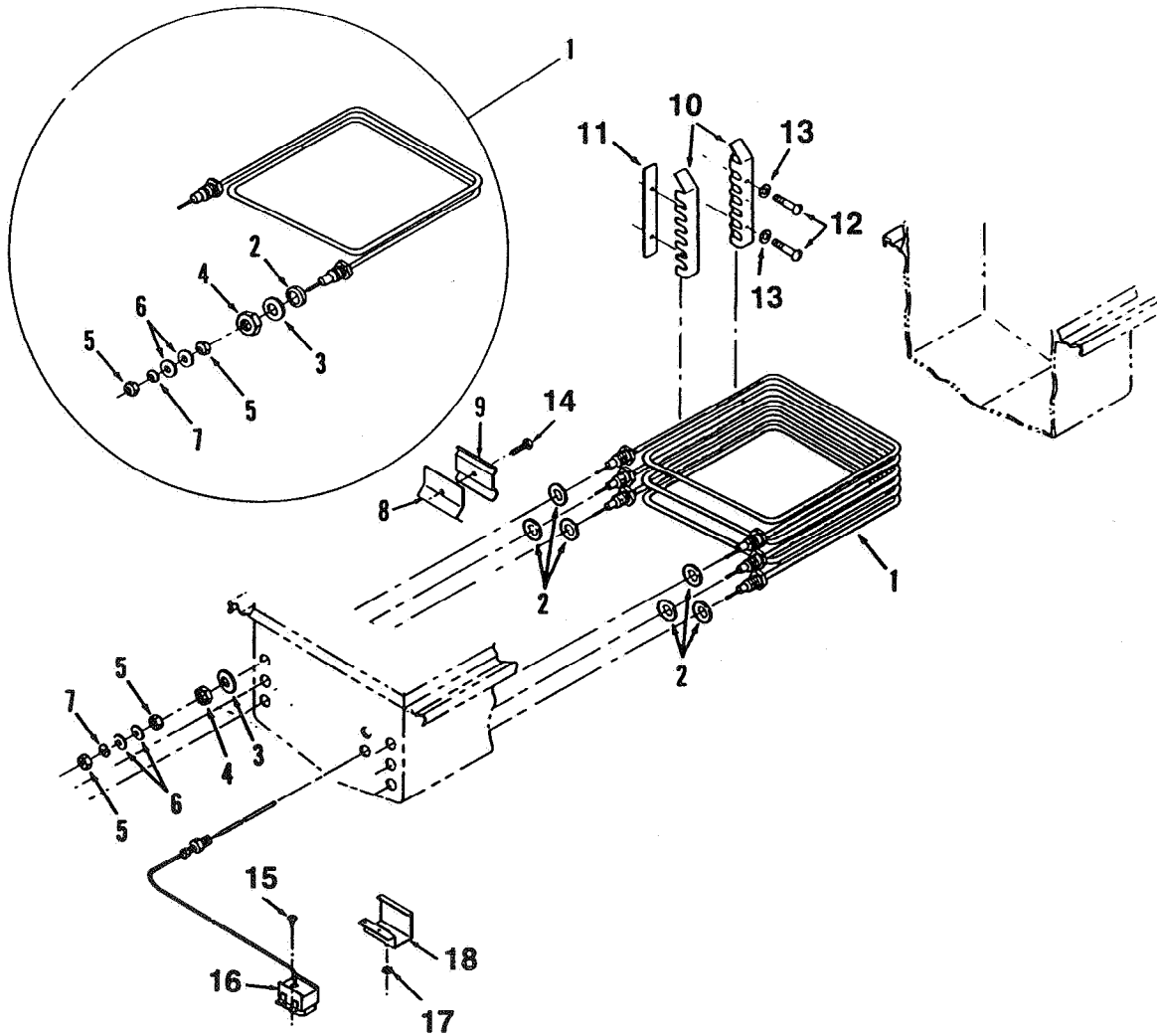

Figure 7-17. Heating Element and High Limit Assembly (Electric Model)

Heating Element and High Limit Assembly (Electric Model)

Item No.	Part Number	Description	Quantity per unit		
			303	302	301
7-17		Heating Element and High Limit Assembly, (Electric Models)			
1	18233-1	Element Complete, Heating, 208 Volts, 4500 Watts	9	6	3
1	18233-2	Element Complete, Heating, 230 Volts, 4500 Watts	9	6	3
1	18233-4	Element Complete, Heating, 208 Volts, 3750 Watts	9	6	3
1	18233-5	Element Complete, Heating, 220 Volts, 3750 Watts	9	6	3
1	18233-6	Element Complete, Heating, 480 Volts, 3750 Watts	9	6	3
1	18233-7	Element Complete, Heating, 480 Volts, 4500 Watts	9	6	3
		(All Elements Include Items 2 Thru 7) Specify Volts and Watts			
2	16855	Seal-O-Ring	18	12	6
3	WA01-005	Washer, Heating Element, Metal	18	12	6
4	NS01-017	Nut, Heating Element, Brass	18	12	6
5	NS01-014	Nut, Heating Element	36	24	12
6	WA01-007	Washer, Heating Element	36	24	12
7	LW01-008	Washer, Lock, Heating Element	18	12	6
8	18720	Clamp, Rear-Hi Limit	3	2	1
9	18248	Clamp, Front	3	2	1
10	18225	Spreader, Element	15	10	5
11	18226	Bar, Spreader Lock	15	10	5
12	SC01-055	Screw, Element Spreader	30	20	10
13	LW01-005	Washer, Lock, Element Spreader	30	20	10
14	SC01-053	Screw, 8-32 x 1/2 PH RD SS	3	2	1
15	SC02-018	Screw, Thread Forming #8	6	4	2
16	16738	Control, Hi Limit Temperature	3	2	1
17	NS02-001	Nut, #10-32 Hex Kepss	6	4	2
18	17216	Bracket Ass'y, Hi Limit Thermostat	3	2	1

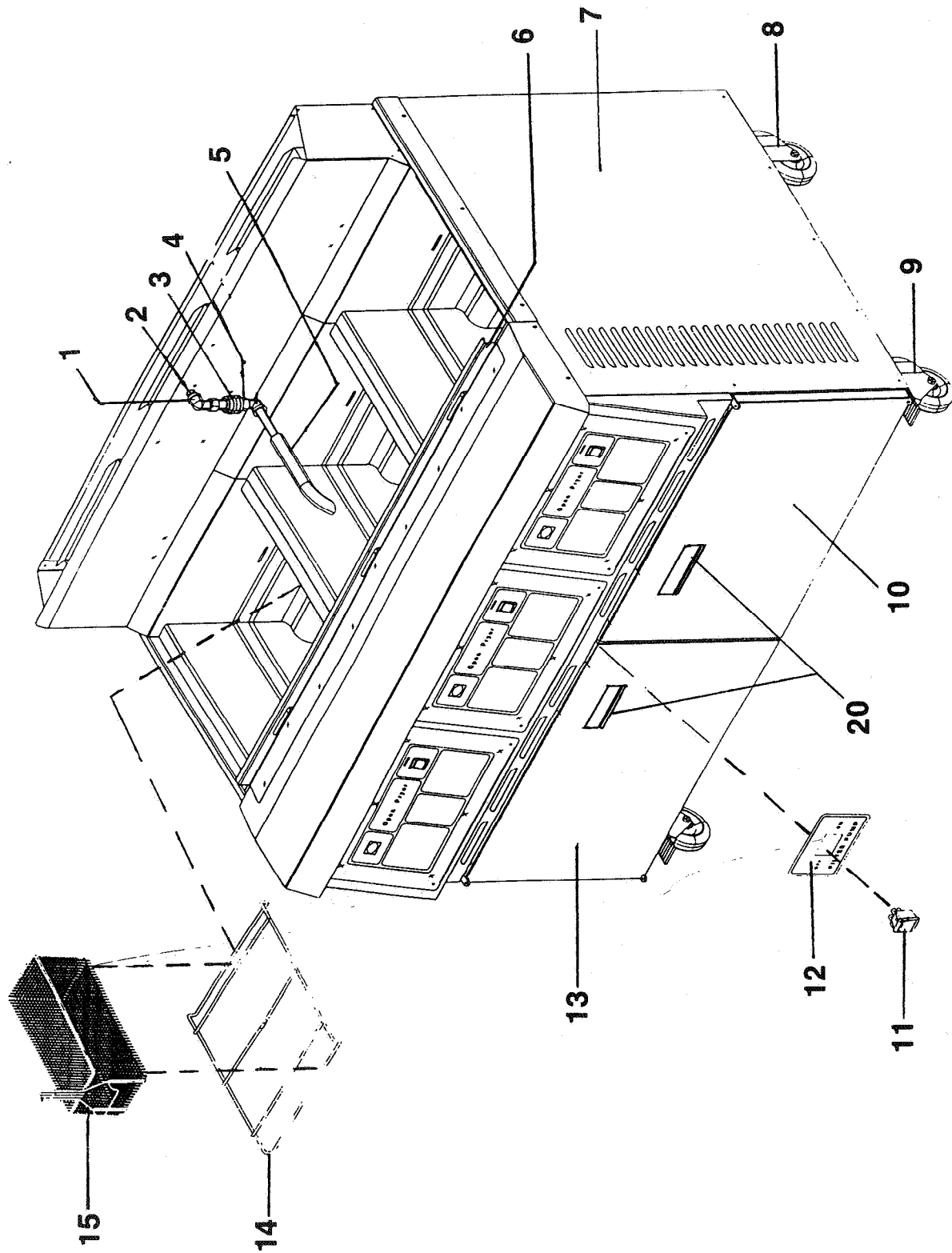

Figure 7-18. 3-Well Front View

3-Well Front View

Item No.	Part Number	Description	Quantity per unit		
			303	302	301
7-18		Fry Station Front View			
1	FP01-087	Elbow, Male - 3/8 in.	1	1	1
2	FP02-001	Nipple, Close - 3/8 in	1	1	1
3	17333	Disconnect, Female	1	1	1
4	17334	Disconnect, Male	1	1	1
5	45402	Line, Return Faucet Only	1	1	-
5	33773	Line, Return Assembly (301)	-	-	1
6	34878	Top Cover Assy. (303)	1	-	-
6	34879	Top Cover Assy. (302)	-	1	-
6	34880	Top Cover Assy. (3 0 1)	-	-	1
7	33286	Side Panel - Right (303/302)	1	1	-
7	55353	Side Panel - Right (301)	-	-	1
7	51864	Side Panel - Right (303/302) - CE Gas	1	1	-
8	33048	Caster (303/302)	2	2	-
8	17630	Caster (301)	-	-	2
9	33041	Locking Caster (303/302)	2	2	-
9	17629	Locking Caster (OG-301)	-	-	2
10	45167	Door Assembly - Right (303)	1	-	-
10	45165	Door Assembly - Right (302)	-	1	-
10	45164	Door Assembly (301)	-	-	1
√ 11	43768	Switch - Filter	1	1	1
12	33109	Decal - Filter	1	1	1
13	45168	Door Assembly - Left (303)	1	-	-
13	45166	Door Assembly - Left (302)	-	1	-
14	33104	Basket Support (Electric Model)	3	2	1
14	33103	Basket Support (Gas Model)	3	2	1
15	33102	Basket - 1/2	6	4	2
15	59078	Basket - 1/3 size (Gas)	-	-	3
16	33288	Side Panel - Left (Gas)	1	1	1
16	55354	Side Panel - Left (Electric)	1	1	1
16	51865	Side Panel - Left (303/302) - CE Gas	1	1	-
17*	33499	Full Size Basket - Gas	3	2	1
18*	33500	Full Size Basket - Electric	3	2	1
19*	33656	Frypot Cover	3	2	1
20	41836	Pocket Pull (Door Handle)	2	2	1
21*	33824	Full Size Basket - OG-303 DS	2	2	-
22*	52776	Gasket - Side Panel (Gas Models)	2	2	2
23*	52779	Gasket - Top Cap - OG-303	1	-	-
24*	52778	Gasket - Top Cap - OG-302	-	1	-

√ recommended parts

*not shown

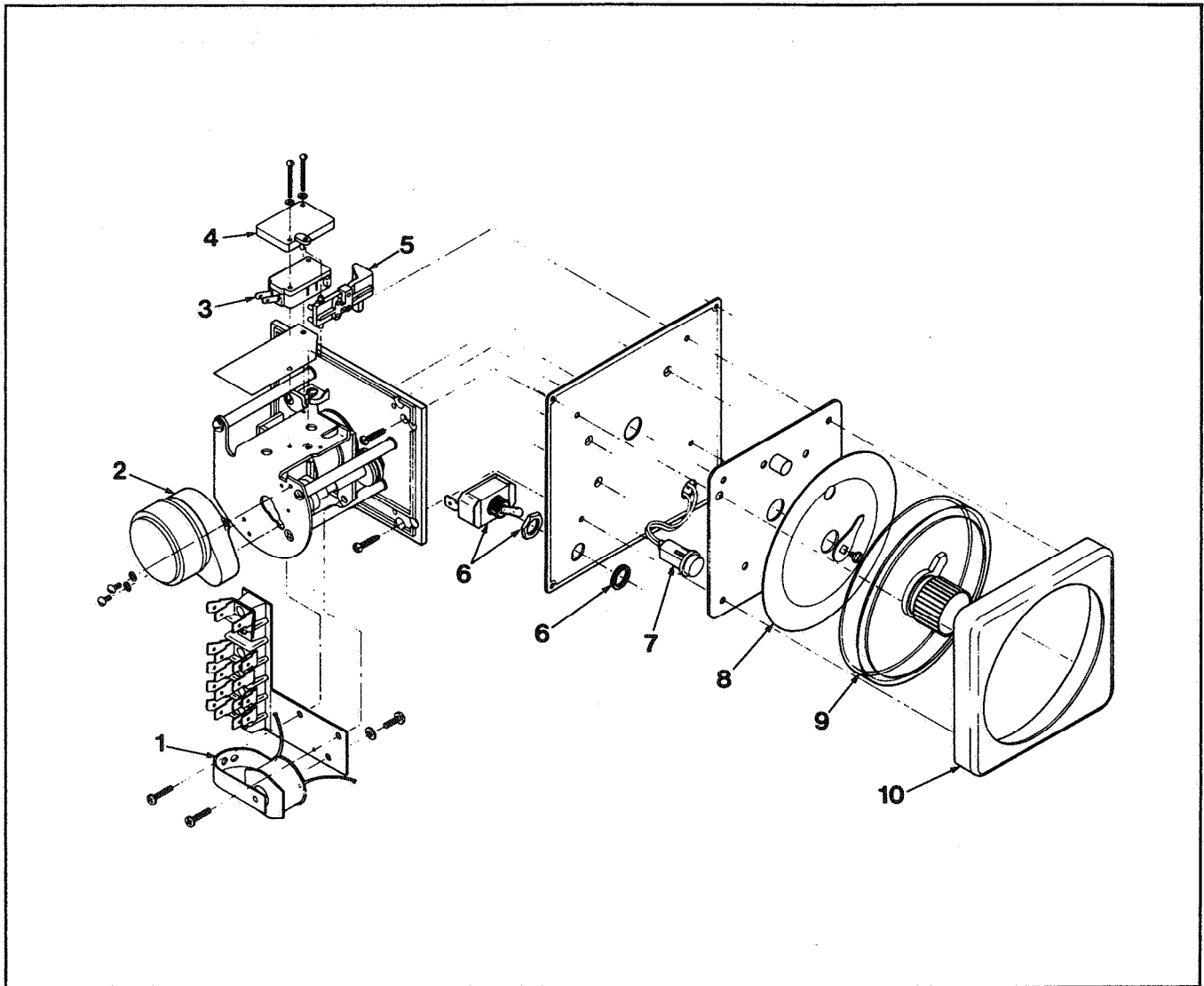

Figure 6-34. Automatic Reset Timer Assembly

FIGURE & ITEM NO.	PART NUMBER	DESCRIPTION	QTY. PER ASSY
AUTOMATIC RESET TIMER ASSEMBLY			
√ 1	16659	BUZZER COIL ASSY, 120 V	1
√ 1	18302	BUZZER COIL ASSY, 208-240 V	1
√ 2	16673	TIMER MOTOR, 120 V	1
√ 2	18303	TIMER MOTOR, 208-240 V	1
√ 3	16671	TIMER MICROSWITCH	1
√ 4	18771	MICROSWITCH MOUNTING PLATE	1
√ 5	18772	MICROSWITCH ACTUATOR ARM	1
√ 6	22195	ON/OFF SWITCH (includes nut)	1
√ 7	16624	INDICATOR LIGHT	1
√ 9	16371	KNOB & POINTER ASSY	1
√ 10	16657	BEZEL	1

√ Recommended Parts

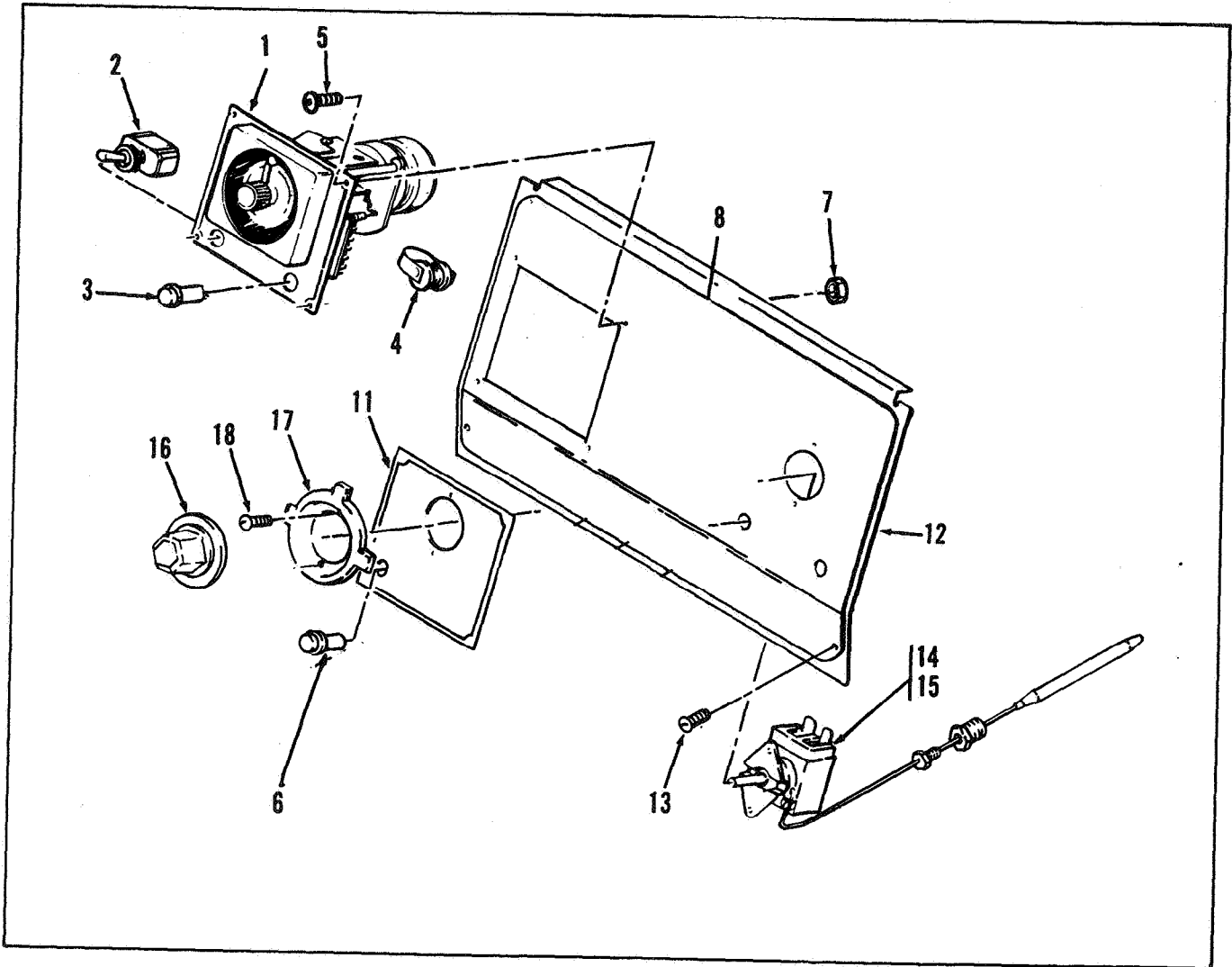

Figure 6-1. Standard Control Panel

FIGURE & ITEM NO.	PART NUMBER	DESCRIPTION	UNITS PER WELL
CONTROL PANEL			
√ 1	18301	TIMER, Automatic Reset, 208-240 Volt 60 Hz	1
√ 1	16602	TIMER, Automatic Reset, 115 Volt 60 Hz	1
√ 1	16596	TIMER, Automatic Reset, 115 Volt 50/60 Hz	1
√ 2	22195	SWITCH, Timer	1
√ 3	16624	LIGHT, Timer Indicator	1
√ 4	16659	COIL, Timer Buzzer, 115 Volt	1
√ 4	18302	COIL, Timer Buzzer, 220 Volt	1
5	SC01-073	SCREW, Timer	4
√ 6	16624	LIGHT, Timer Indicator	3
7	NS02-009	NUT, Timer	4
8	45233	DECAL	1
√ 9	43768	SWITCH, Main	1
11	16745	PLATE, Thermostat	1
12	45232	PANEL, Control	1
13	SC01-034	SCREW, Control Panel	2
√ 14	14648	KIT, Thermostat Control - OE-30X	1
√ 14	14293	KIT, Thermostat Control - OG-30X	1
15	N/A	THERMOSTAT, Body Only	1
√ 16	16706	KNOB, Thermostat	1
√ 17	16704	BEZEL, Thermostat	1
√ 18	SC01-023	SCREW, Thermostat	2

√ Recommended Parts