

HOBART

**CATALOG OF
REPLACEMENT PARTS**



**MODEL 1871
SCALE/PRINTER**

ML-28762 1871M
ML-28761 1871F

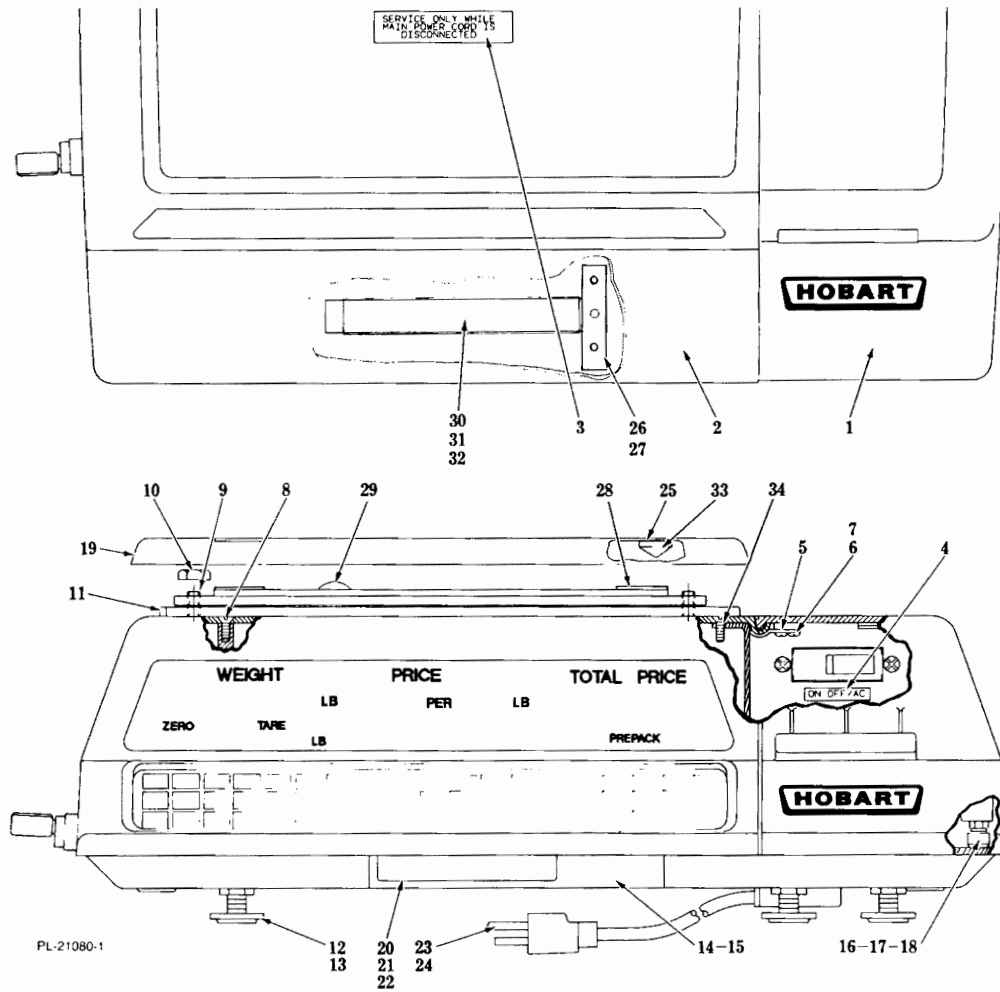

HOUSING

HOUSING

ILLUS. PL-21080-1	PART NO.	NAME OF PART ³⁶	AMT.
1	258115-2	Cover - Printer	1
2	258461	Cover - Scale	1
3	252568	Label - UL Service	1
4	258918	Label - On-Off/AC	1
5	258292	Clip Hinge	2
6	SC-18-30	Mach. Screw 8-32 x 1/4 Phil. Pan Hd	4
7	WL-8-7	Lock Washer 8 Int. Shakeproof	4
8	SC-20-29	Mach. Screw 8-32 x 1/2 Phil., Flat Hd	4
9	41034	Set Screw 1/4-20 x 3/8 "Nylok"	4
10	NS-17-3	Mach. Nut 1/4-20 Hex Jam	AR
11	258175	Platter Support Assy. (Incls. items 28 & 29)	1
12	258327	Foot - Leveling	4
13	258287	Strip - Scale Retainer	1
14	258277	Screen - Base (3" x 3 3/8")	1
15	SD-15-30	Self-Tapping Screw 8-32 x 3/8 Phil. Pan Hd., Type TT	4
16	258343	Bumper - End	1
17	SC-89-70	Cap Screw 10-32 x 3/8 Soc. Hex Hd	1
18	NS-9-30	Mach. Nut 10-32 Hex	1
19	258154	Platter Assy. (Incls. items 25 & 33)	1
20	258467	Plate - Data (1871F) (Include Serial No. of Scale)	1
21	258465	Plate - Data (1871M) (Include Serial No. of Scale)	1
22	SD-33-15	Self-Tapping Screw 0 x 3/8 Rd. Hd., Type U	2
23	257200	Power Cord Assy	AR
24	334654	Power Cord Assy. W/Right Angle Connector	AR
25	258959	Fastener - Dual Lock (Type 400)	4
26	259696	Bar - Keyboard Mounting	1
27	SD-33-71	Self-Tapping Screw 4-24 x 1/4 Hex Washer Hd., Type BT	2
28	258958	Fastener - Dual Lock (Type 170)	4
29	259515	Contact - Finger (16 pieces)	1
30	259698	Relief Clamp Assy	1
31	SC-18-50	Mach. Screw 6-32 x 1/4 Pan Hd	1
32	WL-8-1	Lock Washer 6 Int. Shakeproof	1
33	257143	Locator - Platter	2
34	WL-19-60	Lock Washer 8 Countersunk	1
	259563	Label - Diagram Threading	1
	258166	Label - Index	1
	76971	Logo - Hobart	1
	*258406	Special Speed Key Overlay Media (15 Foot Roll)	1
	538385	Adhesive (Use with item 33)	AR
	538385-2	Accelerator (Use with item 33)	AR

*Used to Make New Speed Key Overlay

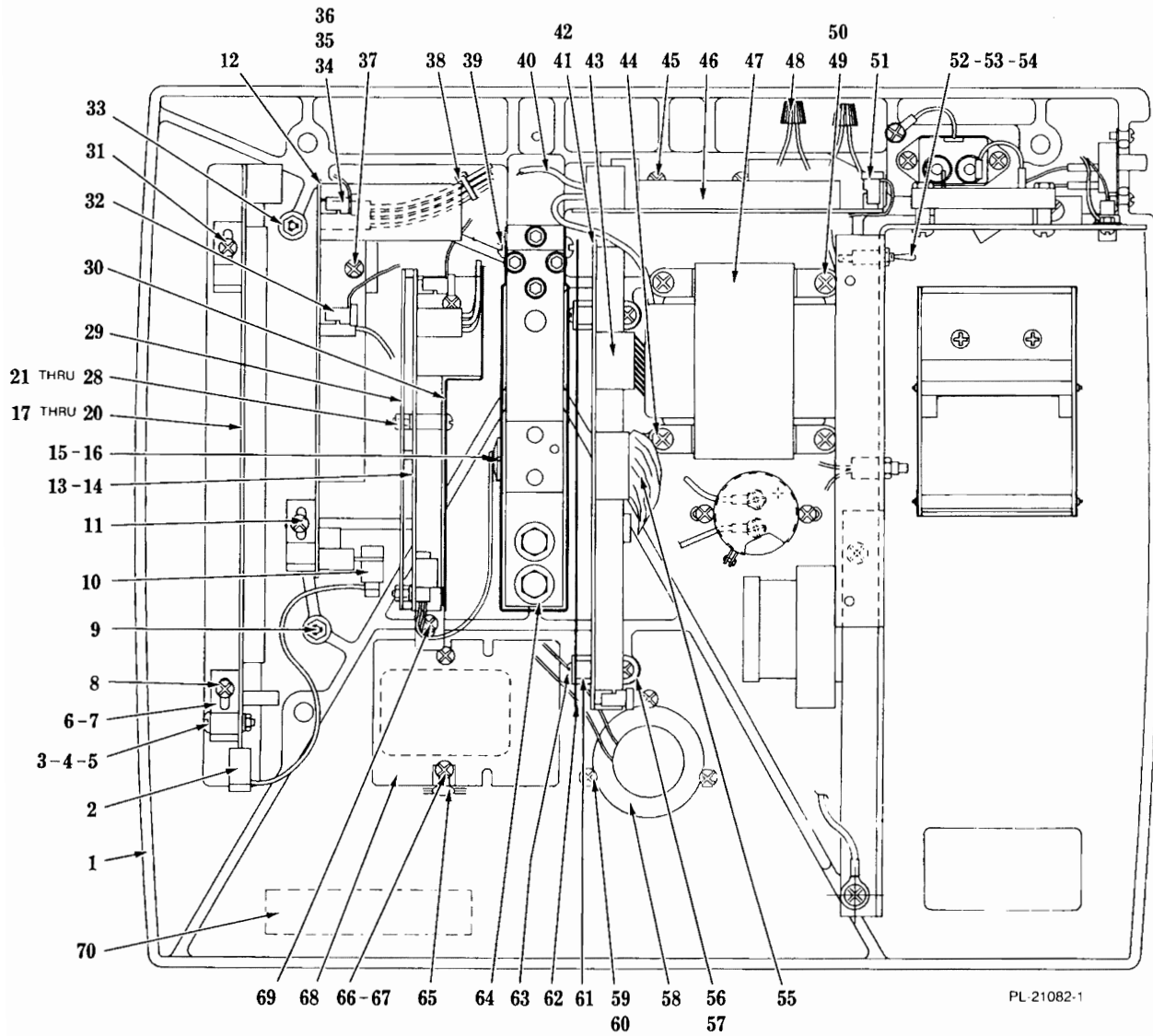

PL 21082-1

BASE

BASE

ILLUS. PL-21082-1	PART NO.	NAME OF PART ³⁶	AMT.
1	258113-2	Base	1
2	259315	Ribbon - Cable Assy	1
3	SC-81-5	Mach. Screw 4-40 x 3/4 Rd. Hd	1
4	WL-8-45	Lock Washer 4 Int. Shakeproof	1
5	NS-9-2	Mach. Nut Hex 4-40	1
6	251993	Block P.C. Board	1
7	2807	Washer - Fiber	1
8	SD-33-91	Self-Tapping Screw 6-32 x 5/16 Phil. Pan Hd., Type TT	1
9	41206	Post - Top Housing Support	2
10	259314	Board - Circuit	1
11	SD-33-91	Self-Tapping Screw 6-32 x 5/16 Phil. Pan Hd., Type TT	1
12	258704	Central Board Assy	1
13	41211	A to D Board Assy	1
14	259011	Bumper - Rubber	3
15	255503	Mount - Cable Tie	1
16	251199	Tie - Cable	4
17	258737-2	Memory Board Assy. (W/O PROMS)	1
18	259578	PROM Kit (Used with Memory Board at U4)	1
19	259579	PROM Kit (Used with Memory Board at U5)	1
20	256627	8K RAM	6
21	SC-113-19	Mach. Screw 4-40 x 7/8 Phil. Pan Hd	2
22	255256	Spacer	1
23	WL-8-45	Lock Washer 4 Int. Shakeproof	3
24	NS-9-2	Mach. Nut Hex 4-40	5
25	258229	Bracket - Mounting	1
26	258302-3	Spacer	1
27	255228	Bracket - Mounting (Heat Sink)	1
28	SC-7-14	Mach. Screw 4-40 x 5/8 Rd. Hd	1
29	259026	Shield - EMI	1
30	258220	Shield - A to D Board	1
31	SD-33-91	Self-Tapping Screw 6-32 x 5/16 Phil. Pan Hd., Type T	1
32	258734-1	CPC to A-D Cable Assy	1
33	256247	Tubing - Insulating	1
34	258768-1	Cassette Harness Assy	1
35	258123-1	Printer - Harness Assy	1
36	183342-1	Display Harness Assy	1
37	SD-33-30	Self-Tapping Screw 6-32 x 7/16 Phil. Pan Hd., Type TT	1
38	251199	Tie - Cable	3
39	SC-62-87	Cap Screw 8-32 x 1/4 Hex Hd	4
40	258763	Grounding Wire Assy	1
41	258557-1	Logic Board Assy. (W/O PROMS)	1
42	259649	PROM Kit (Used with Logic Board at U15)	1
43	258158-1	Motor Control Harens Ass. (Incls. item 52)	1
44	WL-7-7	Lock Washer 8 Ext. Shakeproof	1
45	SD-33-91	Self-Tapping Screw 6-32 x 5/16 Phil. Pan Hd. Type TT	2
46	183183-1	Power Supply Board Assy	1
47	258241	Transformer Assy	1
48	FE-6-17	Connector - Wire Nut	2
49	SD-15-30	Self-Tapping Screw 8-32 x 5/16 Phil. Pan Hd., Type TT	4
50	WL-7-7	Lock Washer 8 Ext. Shakeproof	1
51	258124-1	Motor Harness Assy	1
52	256675	Switch - Toggle (Label Media)	1
53	256676	Label - Switch	1
54	NS-47-44	Jam Nut 1/4-40 Hex	1
55	255430	Ribbon Cable - Printer	1
56	255411	Bracket - Logic Board	2
57	SD-15-30	Self-Tapping Screw 8-32 x 5/16 Phil. Pan Hd., Type TT	2
58	182212	Speaker Assy	1
59	SD-33-91	Self-Tapping Screw 6-32 x 5/16 Phil. Pan Hd., Type TT	3
60	WS-23-48	Washer	3
61	255527	Support - P.C. Board	4
62	258228	Shield - Logic Board	1
63	SD-15-37	Self-Tapping Screw 6-32 x 1/4 Phil. Pan Hd., Type TT	4
64	258218	Shield - Flexure	1
65	253363	Clamp	1
66	SD-33-30	Self-Tapping Screw 6-32 x 7/16 Phil. Pan Hd., Type TT	2
67	WS-23-48	Washer	1
68	258336	Plate - Cover	1
69	SD-33-91	Self-Tapping Screw 6-32 x 5/16 Phil. Pan Hd., Type TT	2
70	255111	Label - Warning	1
	519504	Thermal Joint Compound (2 oz.)	1

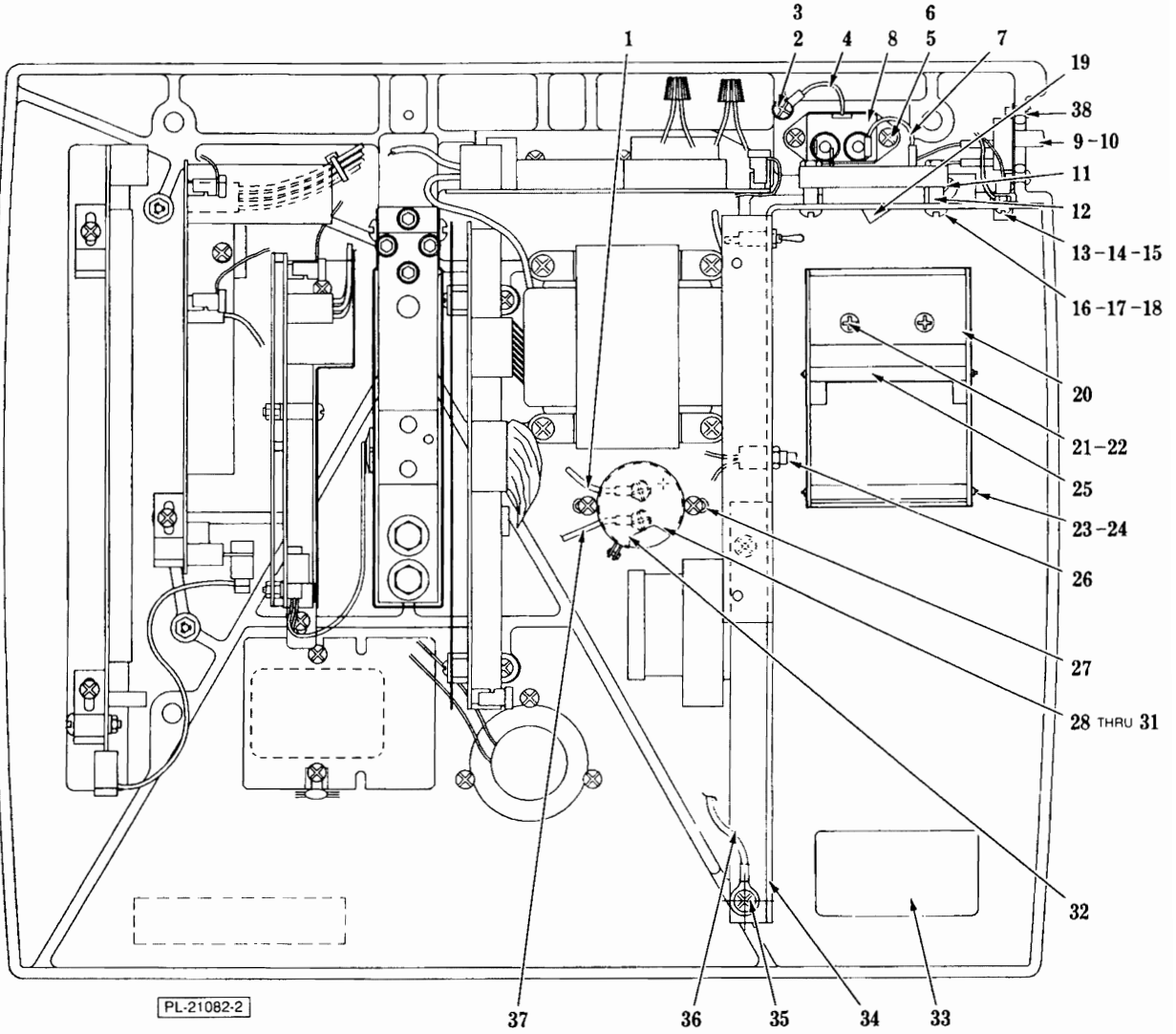

BASE

BASE

ILLUS. PL-21082-2	PART NO.	NAME OF PART ³⁶	AMT.
1	258204	Wire Assy. Capacitor	1
2	SD-15-30	Self-Tapping Screw 8-32 × $\frac{1}{16}$ Phil. Pan Hd., Type TT	1
3	WL-7-7	Lock Washer 8 Ext. Shakeproof	1
4	258252	Wire Assy	1
5	SC-113-10	Mach. Screw 4-40 × $\frac{3}{8}$ Phil. Pan Hd	2
6	WL-8-45	Lock Washer 4 Int. Shakeproof	2
7	258203	Wire Assy	1
8	258120	Wire Assy. (Filter)	1
9	258696	Power Switch & Harness Assy	1
10	258117	Label (On/Off/Rezero)	1
11	WL-7-7	Lock Washer 8 Ext. Shakeproof	1
12	133133	Spacer	2
13	SC-113-10	Mach. Screw 4-40 × $\frac{3}{8}$ Phil. Pan Hd	2
14	WL-8-45	Lock Washer 4 Int. Shakeproof	2
15	NS-9-2	Mach. Nut 4-40 Hex	2
16	SC-74-12	Mach. Screw 6-32 × $\frac{7}{8}$ Phil. Rd Hd	2
17	NS-9-7	Mach. Nut 6-32 Hex	2
18	WL-8-1	Lock Washer 6 Int. Shakeproof	2
19	258255	Breaker - Rocker	1
20	258463	Holder - Paper roll	1
21	SD-15-30	Self-Tapping Screw 8-32 × $\frac{1}{16}$ Phil. Pan Hd., Type TT	2
22	WS-28-6	Washer	2
23	41229	Shaft - Paper	2
24	RR-4-23	Retaining Ring	4
25	258110	Tube - Paper	2
26	41029	Switch - Label Advance (Incls. $\frac{1}{4}$ -32 Nut)	1
27	SD-33-91	Self-Tapping Screw 6-32 × $\frac{1}{16}$ Phil. Pan Hd., Type TT	2
28	255505	Capacitor	1
29	258119	Bracket - Capacitor	1
30	SC-18-29	Mach. Screw 6-32 × $\frac{3}{8}$ Phil. Pan Hd	1
31	NS-9-7	Mach. Nut 6-32 Hex	1
32	256532	Cap - Capacitor	1
33	258399	Diagram - Cover Removal	1
34	258107	Bracket - Mounting	1
35	SD-15-30	Self-Tapping Screw 8-32 × $\frac{1}{16}$ Phil. Pan Hd., Type TT	2
36	258522	Cable Assy. (Scale Cover Restraint)	1
37	258691	Wire Assy	1
38	SC-71-6	Mach. Screw 6-32 × $\frac{1}{16}$ Phil. Truss Hd	2

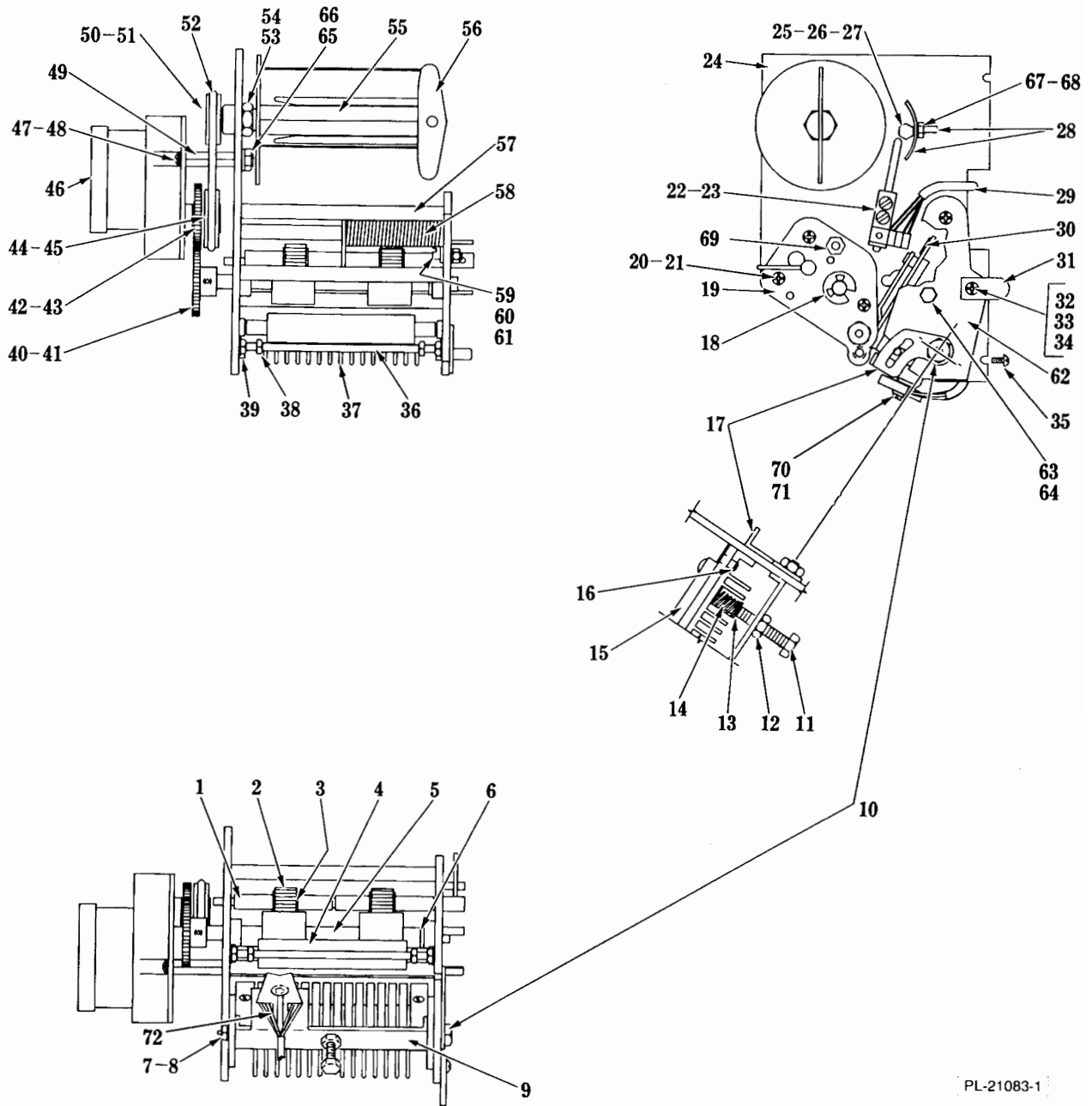

PL-21083-1

PRINTING UNIT

ILLUS. PL-21083-1	PART NO.	NAME OF PART ³⁶	AMT.
	1	Tension Shaft & Roll Pin Assy	1
	2	Roll - Tension	2
	3	Ring - Retaining	4
	4	Pressure Roll & Shaft Assy	1

PRINTING UNIT (Cont.)

ILLUS. PL-21083-1	PART NO.	NAME OF PART ³⁶	AMT.
5	258101	Drive Roll & Shaft Assy	1
6	RR-10-6	Retaining Ring	1
7	SC-18-29	Mach. Screw 6-32 × 3/8 Phil. Pan Hd	1
8	WL-8-1	Lock Washer 6 Int. Shakeproof	1
9	258517	Bracket - Sensor Mounting	1
10	258367	Screw - Printer Cam	1
11	SC-117-85	Mach. Screw 6-32 × 1 1/8 Hex Hd	1
12	NS-9-7	Mach. Nut 6-32 Hex	1
13	258187	Guide - Spring	1
14	41033	Spring - Compression	1
15	257645	Thermal Printer Head Assy	1
16	SC-18-68	Mach. Screw 4-40 × 1/4 Phil. Pan Hd	4
17	258266	Cam - Printer Head	1
18	RR-10-6	Retaining Ring	1
19	258129	Right Side Frame Assy	1
20	NS-9-3	Mach. Nut 5-40 Hex	1
21	WL-8-47	Lock Washer 5 Int. Shakeproof	1
22	258091	Plate - Screw	1
23	SC-117-93	Mach. Screw 5-40 × 3/8 Phil., Pan Hd	2
24	258127	Left Side Frame Assy	1
25	258092	Shaft - Paper Guide	1
26	NS-17-60	Jam Nut 1/4-28 Hex	1
27	WL-3-39	Lock Washer 1/4 Light	1
28	258093	Guide - Paper	1
29	258240	Sensor Harness Assy	1
30	257347	Label - Rating	1
31	41031	Foot - Printer	1
32	SC-18-29	Mach. Screw 6-32 × 3/8 Phil. Pan Hd	1
33	WL-8-1	Lock Washer 6 Int. Shakeproof	1
34	WL-3-9	Lock Washer 6 Regular	1
35	SC-117-94	Mach. Screw 10-32 × 3/8 Phil., Fil. Hd	3
36	258086	Shaft - Peel	1
37	41162	Heatsink - Print Head Assy	1
38	258087	Screw - Peel Shaft	2
39	258209	Nut - Special	2
40	256844	Gear - Spur (44T)	1
41	SC-47-84	Set Screw 6-32 × 3/8 Soc. Hdls., Cup Pt	1
42	256845	Gear - Spur (56T)	1
43	SC-116-35	Set Screw 4-40 × 3/4 Soc. Hdls., Cup Pt	1
44	258083	Pulley - Paper Take-up (1" O.D.)	1
45	SC-47-84	Set Screw 6-32 × 3/8 Soc. Hdls. Cup Pt	1
46	258125	Motor Assy	1
47	SC-18-29	Mach. Screw 6-32 × 3/8 Phil. Pan Hd	2
48	WL-8-1	Lock Washer 6 Int. Shakeproof	4
49	258055	Standoff - Motor	2
50	258084	Pulley - Paper Take-up (7/8 O.D.)	1
51	SC-47-84	Set Screw 6-32 × 3/8 Soc. Hdls., Cup Pt	1
52	258160	Spring - Take-up Drive	1
53	41038	Hub Assy	1
54	41032	Nut - Special	1
55	258096	Flange & Hub Assy	1
56	258089	Key - Label Roll	1
57	258053	Shaft - Spacer	5
58	258142	Spring - Torsion	1
59	258106	Screw - Adjusting	1
60	SC-18-26	Mach. Screw 5-40 × 1/4 Phil. Pan Hd	2
61	WL-8-47	Lock Washer 5 Int. Shakeproof	2
62	258105	Frame - Lower Side	1
63	41208	Screw - Dowel	2
64	WL-3-14	Lock Washer 8 Light	1
65	NS-9-7	Mach. Nut 6-32 Hex	1
66	WL-8-1	Lock Washer 6 Int. Shakeproof	1
	519504	Thermal Joint Compound (2 oz.)	1

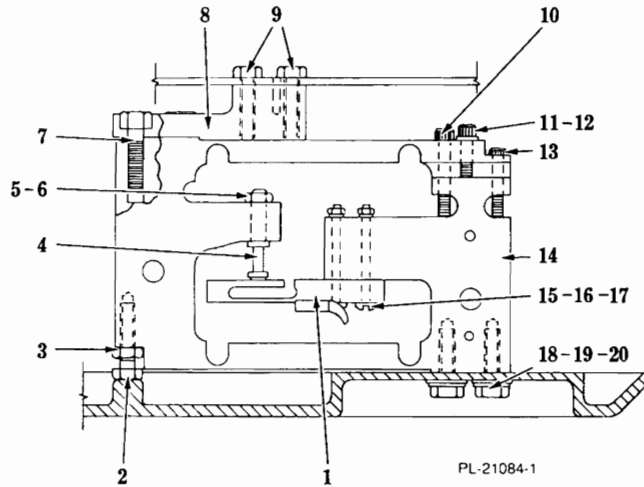

LOAD CELL

ILLUS. PL-21084-1	PART NO.	NAME OF PART ³⁶	AMT.
1	257479	Load Cell Kit (Replaces HBM or Revere) (Incls. items 4 & 17)	1
2	SC-36-13	Cap Screw 1/4-20 x 3/4 Hex Hd	1
3	NS-17-3	Jam Nut 1/4-20 Hex Fin	1
4	257634	Link - Load Cell	1
5	NS-13-2	Nut 1/4-20 Hex	1
6	WS-3-19	Washer	1
7	SC-36-13	Cap Screw 1/4-20 x 3/4 Hex Hd	2
8	183343	Block - Assy	1
9	SC-36-13	Cap Screw 1/4-20 x 3/4 Hex Hd	2
10	258628	Screw - Socket Hd	1
11	SC-112-98	Cap Screw 10-32 x 1 1/4 Socket Hex Hd	2
12	WS-28-18	Washer	2
13	SC-92-8	Cap Screw 10-32 x 1 1/8 Socket Hex Hd	1
14	259441	Flexure - Load Cell	1
15	WL-3-14	Lock Washer 8 Light	2
16	NS-9-12	Mach. Nut 8-32 Hex Hd	2
17	SC-18-67	Mach. Screw 8-32 x 1 3/4 Phil. Pan Hd	2
18	SC-89-2	Cap Screw 1/4-20 x 3/4 Socket Hex Hd	2
19	WL-3-39	Lock Washer 1/4 Light	2
20	WS-3-19	Washer	2

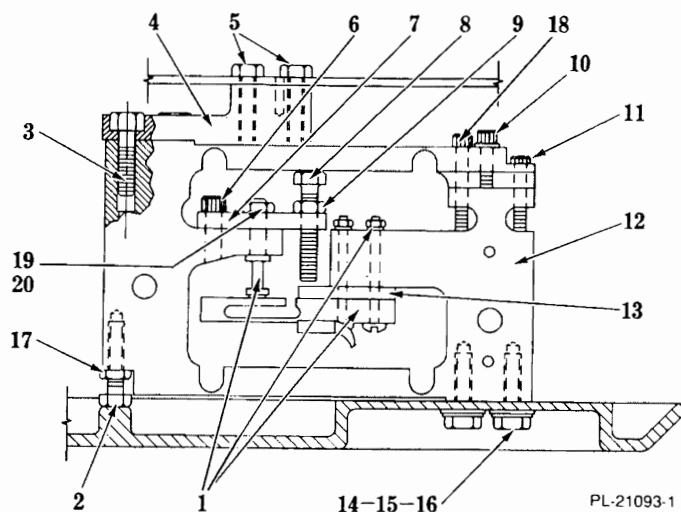

**LOAD CELL
(WITH SPACERS)**

ILLUS. PL-21093-1	PART NO.	NAME OF PART ³⁶	AMT.
1	257479	Load Cell Kit (Replaces HBM or Revere)	1
2	SC-36-13	Cap Screw 1/4-20 x 3/4 Hex Hd	1
3	SC-36-13	Cap Screw 1/4-20 x 3/4 Hex Hd	2
4	183343	Block Assy	1
5	SC-36-13	Cap Screw 1/4-20 x 3/4 Hex Hd	2
6	SC-89-2	Cap Screw 1/4-20 x 3/4 Socket Fil. Hd	1
7	*	Block - Limit	1
8	*	Screw - Special	1
9	NS-17-60	Jam Nut 1/4-28 Hex	1
10	SC-112-98	Cap Screw 10-32 x 1 1/4 Socket Fil. Hd	2
11	SC-92-8	Cap Screw 10-32 x 1 1/8 Socket Fil. Hd	1
12	*	Flexure - Load Cell	1
13	252257	Spacer	1
14	SC-89-2	Cap Screw 1/4-20 x 3/4 Soc. Hd	2
15	WL-3-39	Lock Washer 1/4 Light	2
16	WS-3-19	Washer	2
17	NS-17-3	Jam Nut 1/4-20 Hex Fin	2
18	258628	Screw - Socket Hd	1
19	NS-13-2	Nut 1/4-20 Hex	1
20	WS-3-19	Washer (Use W/item 12)	1

*Not available, order 259441 & item 20.

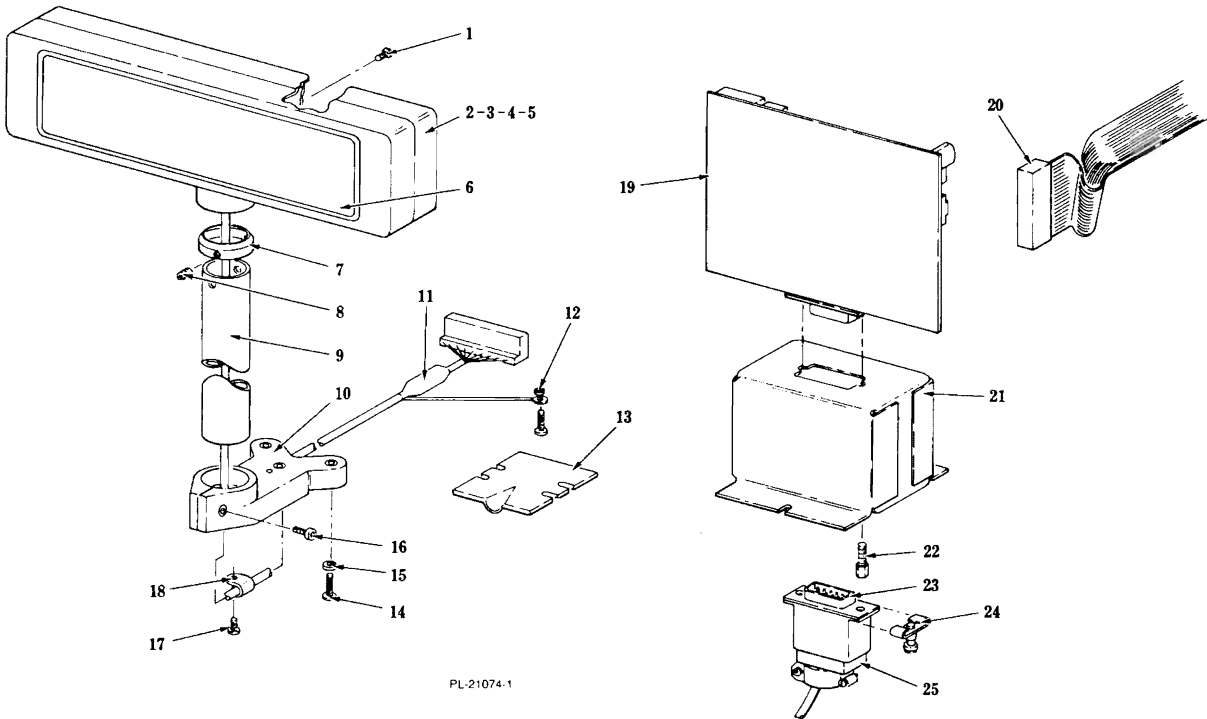

KITS

KITS

ILLUS. PL-21074-1	PART NO.	NAME OF PART ³⁶	AMT.
1	SD-33-19	Self-Tapping Screw 4-24 x 3/8 Hex Washer Hd., Type BT	7
2	258350	Housing - Display (With Opening)	1
3	258351	Housing - Display (Without Opening)	1
4	WS-23-48	Washer	8
5	NS-46-20	Special Nut - 3/32 Stud "Palnut"	8
6	255553	Screen - Display	1
7	253676	Ring - Display Lock	1
8	SC-88-70	Set Screw 10-24 x 1/4 Cup Pt	2
9	253679	Column - Display	1
10	253652-2	Base - Column Support	1
11	258297-1	Elevated Display Cable Assy	1
12	WL-7-7	Lock Washer 8 Ext. Shakeproof	1
13	258336	Plate - Cover	1
14	SC-18-37	Mach. Screw 8-32 x 3/4 Phil. Pan Hd	3
15	WL-8-7	Lock Washer 8 Int. Shakeproof	3
16	SC-87-5	Cap Screw 1/4-28 x 3/8 Socket Hd	1
17	SC-18-31	Mach. Screw 8-32 x 3/8 Phil. Pan Hd	1
18	30696	Clamp - Cable	1
19	259719	Interface Board Assy	1
20	259032	Ribbon Cable Assy	1
21	258128	Bracket - Interface	1
22	257128	Screw Lock Assy. (Female)	2
23	257195	Socket - Plug	1
24	257196	Screw Lock Assy. (Male)	2
25	257194	Housing - Plug	1
	255577	Restraint - Display Cable	1
	253723-2	Screen - Blank	1

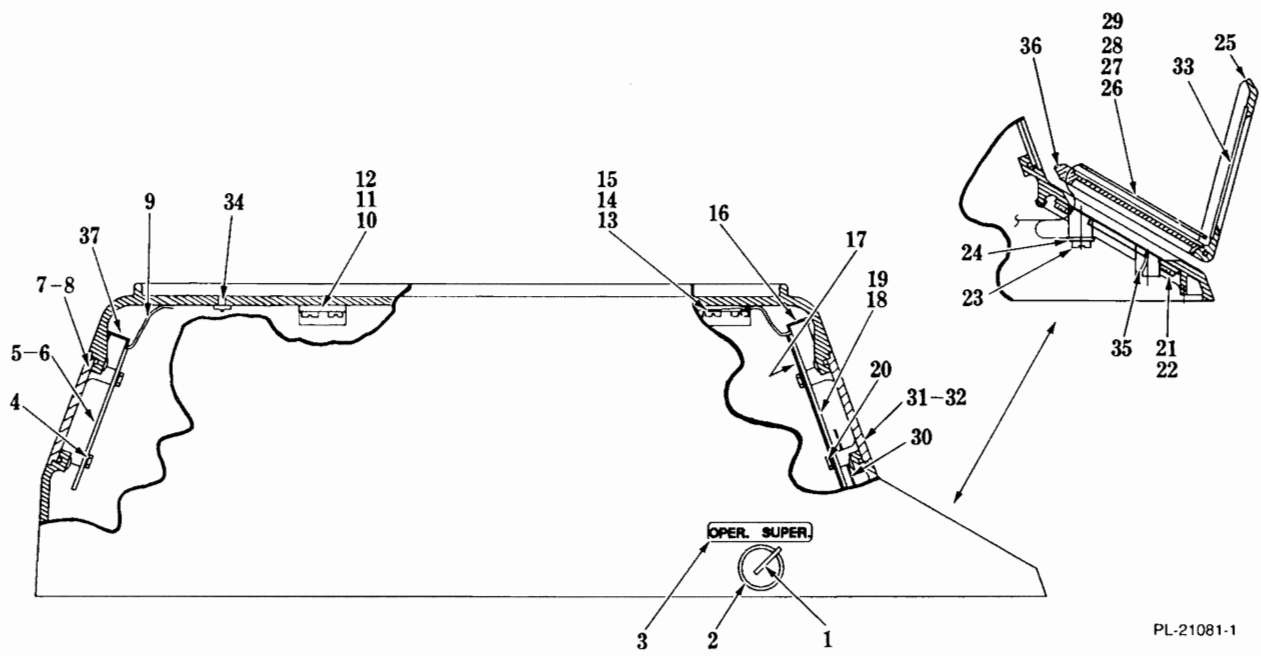

PL-21081-1

KEYBOARD AND DISPLAY

KEYBOARD AND DISPLAY

ILLUS. PL-21081-1	PART NO.	NAME OF PART ³⁶	AMT.
1	258669	Key - Switch Lock (Supervisor)	1
2	255254-1	Lock Switch & Connector Assy. (Incls. item 1)	1
3	258430	Label - Switch Plate	1
4	SD-33-19	Self-Tapping Screw 4-24 x 3/8 Hex Washer Hd., Type TT	4
5	255544-1	Display Board Assy. (Multiple)	1
6	255544-2	Display Board Assy. (Fractional)	1
7	258550	Screen - Display (30 Lb.) (W/O Elevated Display)	1
8	253723-2	Screen - Blank (W/Elevated Display)	1
9	258121	Display Cable Assy	1
10	258469	Stop - Spring	1
11	SD-15-39	Mach. Screw 8-32 x 1/4 Phil. Pan Hd	2
12	WL-8-7	Lock Washer 8 Int. Shakeproof	2
13	258344	Latch - Spring	1
14	SD-15-39	Mach. Screw 8-32 x 1/4 Phil. Pan Hd	2
15	WL-8-7	Lock Washer 8 Int. Shakeproof	2
16	255560	Cover - 26 Pin Connector	1
17	257466	Shield - Display Board	1
18	255546-1	Display Control Board Assy. (Multiple)	1
19	255546-2	Display Control Board Assy. (Fractional)	1
20	SD-33-19	Self-Tapping Screw 4-24 x 3/8 Hex Washer Hd., Type TT	4
21	WS-23-21	Washer	6
22	SD-33-71	Self-Tapping Screw 4-24 x 1/4 Hex Washer Hd., Type BT	6
23	SD-33-91	Self-Tapping Screw 6-32 x 3/16 Phil. Pan Hd., Type TT	1
24	WS-23-21	Washer	1
25	258404	Bezel & Overlay Assy. (Incls. item 33)	1
*26	175501	Keyboard Switch & Overlay Assy. (Multiple)	1
*27	175502	Keyboard Switch & Overlay Assy. (Fractional)	1
28	175498	Keyboard Switch & Overlay (Multiple) (1 3/4" Ribbon Cable)	1
29	175500	Keyboard Switch & Overlay (Fractional) (1 3/4" Ribbon Cable)	1
30	259660	Cover - Display Board	1
31	258550	Screen - Display (30 lb.)	1
32	259407	Screen - Display (14 Kg.)	1
33	258405	Overlay - Bezel	1
34	255502	Tie - Cable	2
35	259699	Cable Assy	1
36	535236	Sealer (RTV162) (10.3 oz.)	1
37	255560	Cover - 26 Pin Connector	1

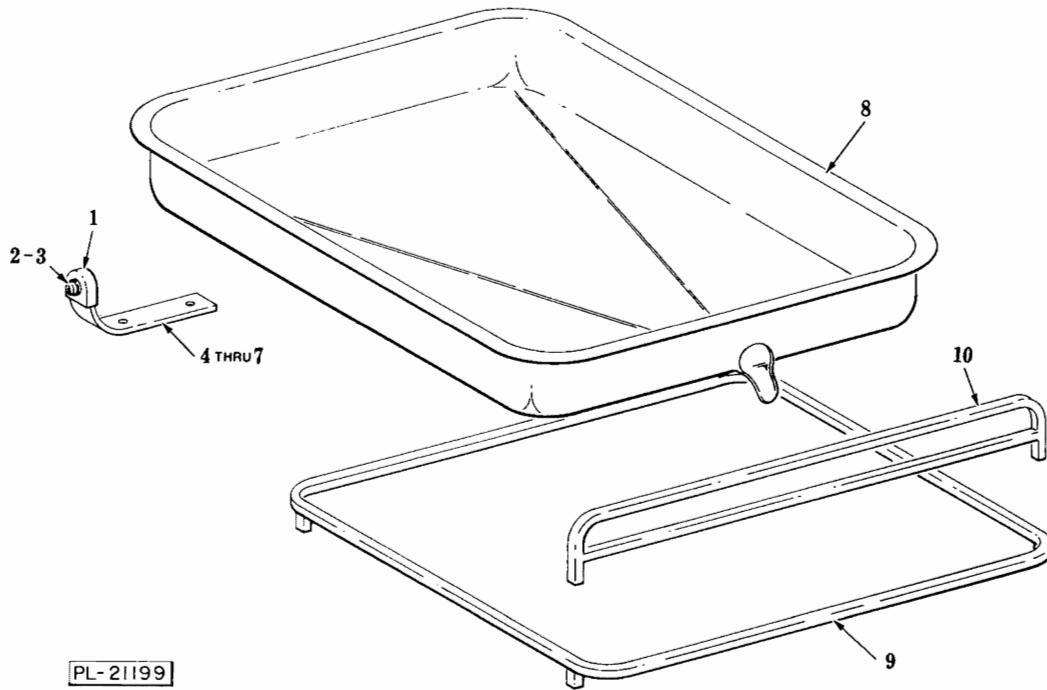

PLATTER UNIT

ILLUS.	PART NO.	NAME OF PART ³⁶	AMT.
PL-21199			
1	13999-1	Tip - Pan Holder	4
2	SC-19-25	Mach. Screw 6-32 x 1/2 Binding Hd	4
3	2807	Washer (Fiber)	4
4	41062	Arm, Veg. & Fish Pan	4
5	SC-111-31	Mach. Screw 6-32 x 1/16 Truss Hd	8
6	WL-13-5	Lock Washer 6 Int. Shakeproof	8
7	NS-11-7	Nut 6-32 Hex	8
8	176129-4	Fish Pan	1
9	182306	Ring Kit Assy. (1800)	1
10	182307	Rail Kit Assy. (1800)	1
	41138	Scoop - Candy	1
	41139	Kit - Fish Pan (Incls. items 1 thru 8)	1