

NO: 71011

ISSUED: SEPT. 13, 1990

REVISED: JAN. 8, 2002



**HOSHIZAKI
ICE DISPENSING BIN**

MODEL

DB-130C

(FINAL) PARTS LIST

K-1	SEPTEMBER 1990
A-0	DECEMBER 1990
A-1	JANUARY 1991
B-0	DECEMBER 1991
B-1	APRIL 1992
C-1	MAY 1993
D-0	DECEMBER 1993
D-1	APRIL 1994
D-2	NOVEMBER 1994
E-0	DECEMBER 1994
F-0	DECEMBER 1995
F-1	MARCH 1996
G-0	DECEMBER 1996
H-0	DECEMBER 1997
J-0	DECEMBER 1998
K-0	DECEMBER 1999
L-0	JANUARY 2001

MATERIAL ABBREVIATIONS

ALUMINUM

AL = Aluminum

COPPER

CU = Copper

PLASTIC

ABS = Acrylonitrile -butadiene - styrene
AC = Polyacetal
EVA = Ethylene vinyl acetate
PA = Polyamide = Nylon
PC = Polycarbonate
PE = Polyethylene
PES = Polyester
PETP = Polyethylene terephthalate = Tetlon
PP = Polypropylene
PS = Polystyrene
PTFE = Polytetrafluoroethylene = Teflon
PUR = Polyurethane
PVC = Polyvinyl chloride

RUBBER

VN = Vinyl Nitrile
EPDM = EP rubber
NBR = Nitrile butadiene rubber
NR = Natural rubber
NP = Neoprene
SI.R = Silicone rubber
SY.R = Synthetic rubber
EPH = Epichlorohydrin

STEEL

GS = Galvanized steel
SS = Stainless steel
PS = Plated steel
PAS = Primed steel

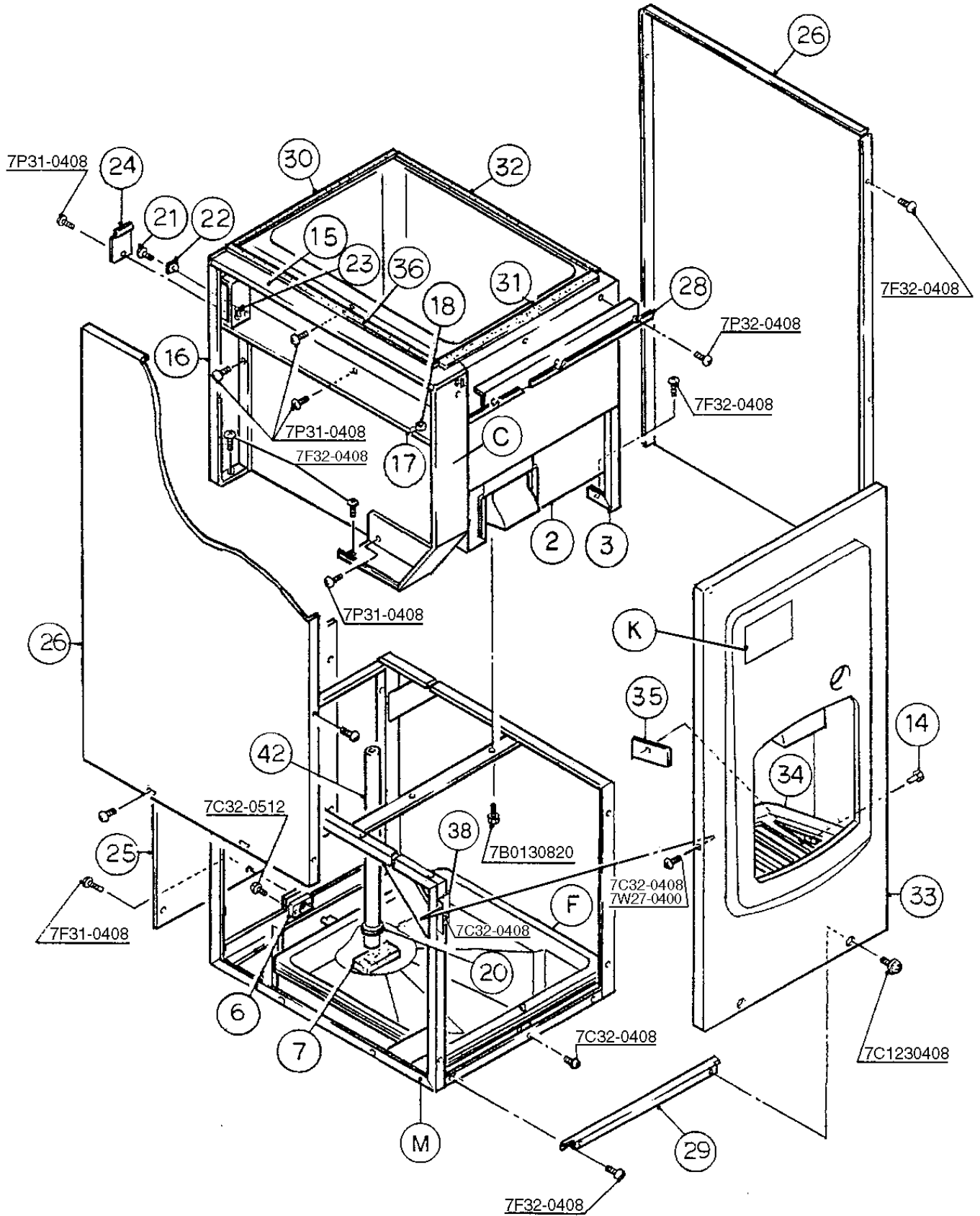

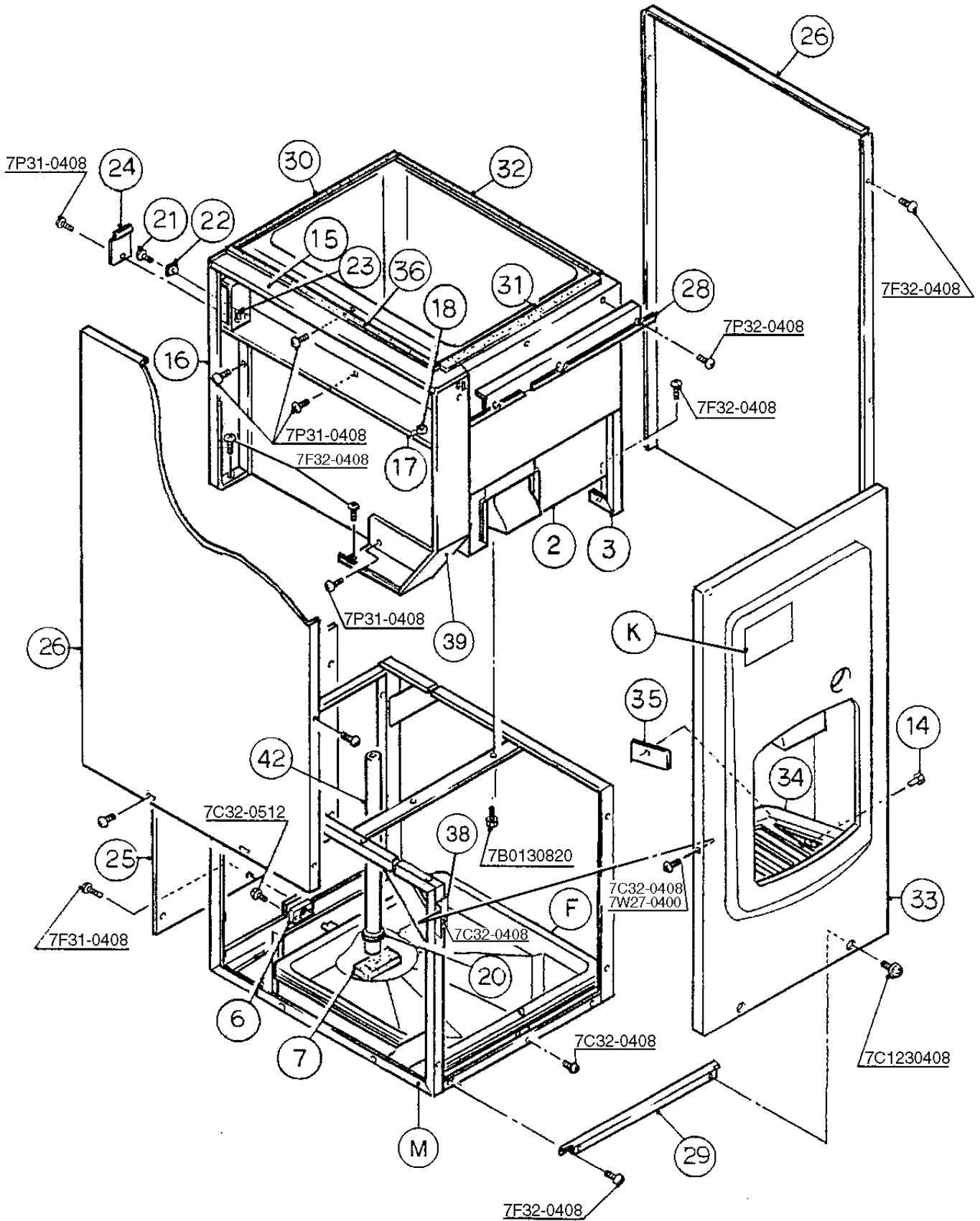

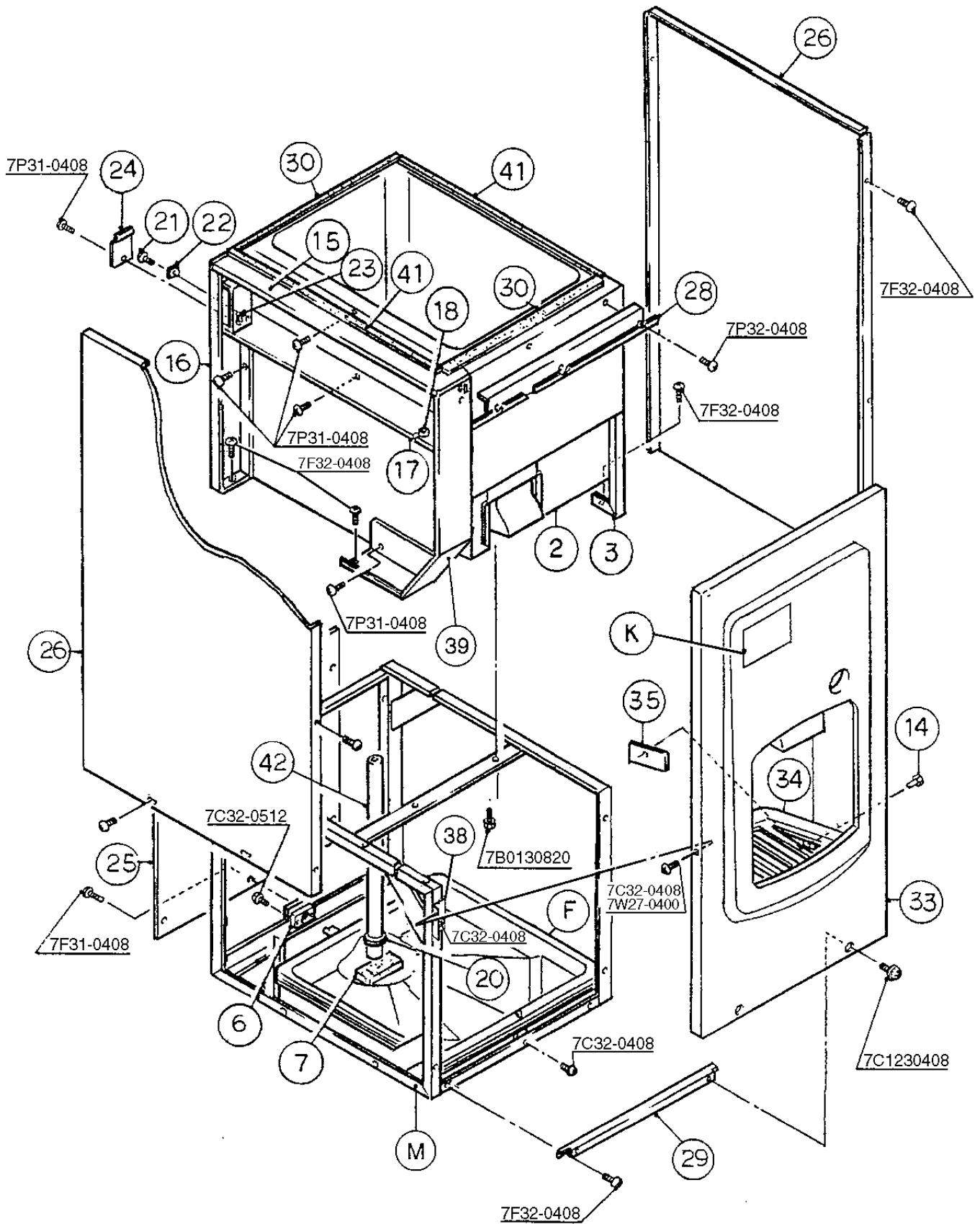

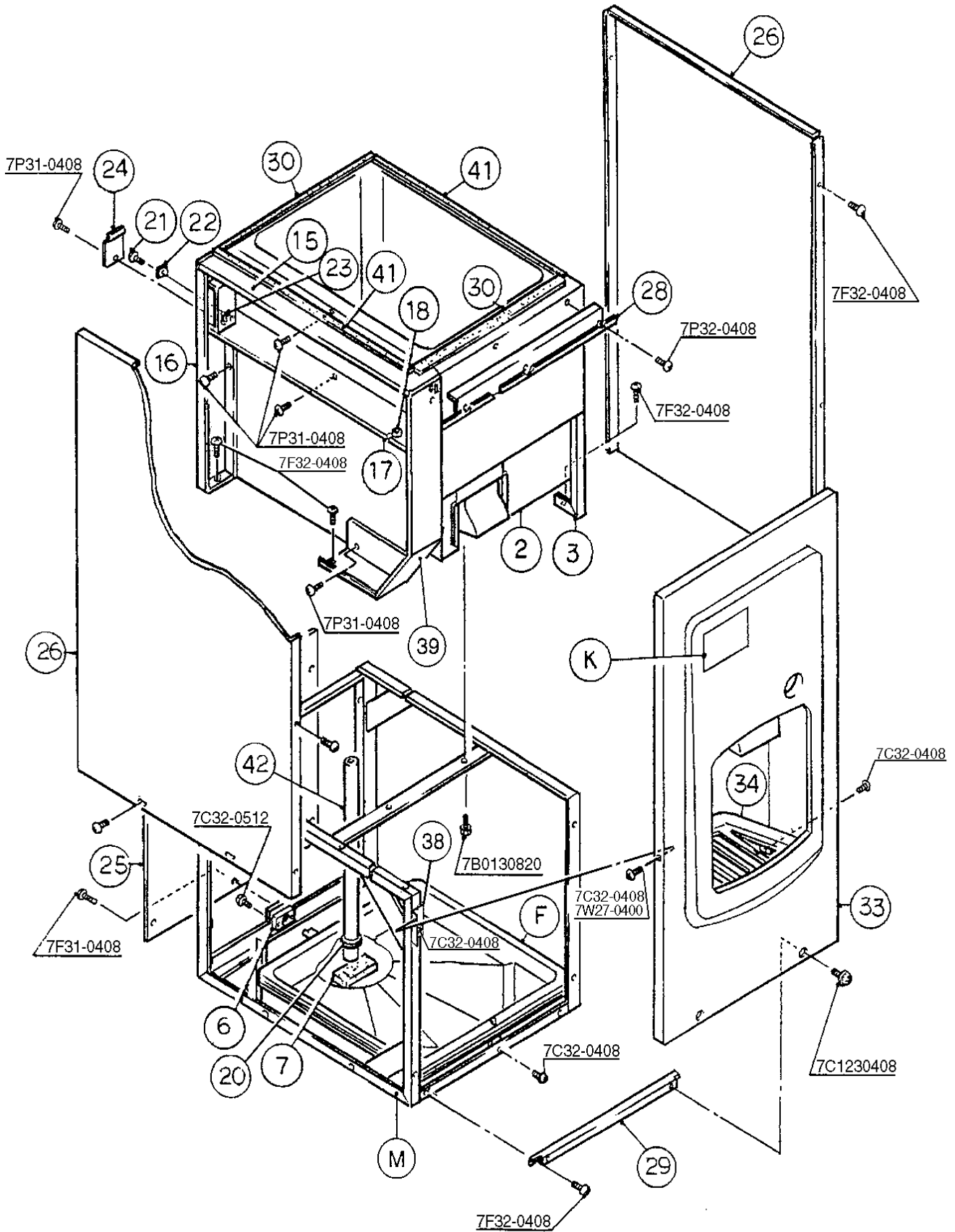

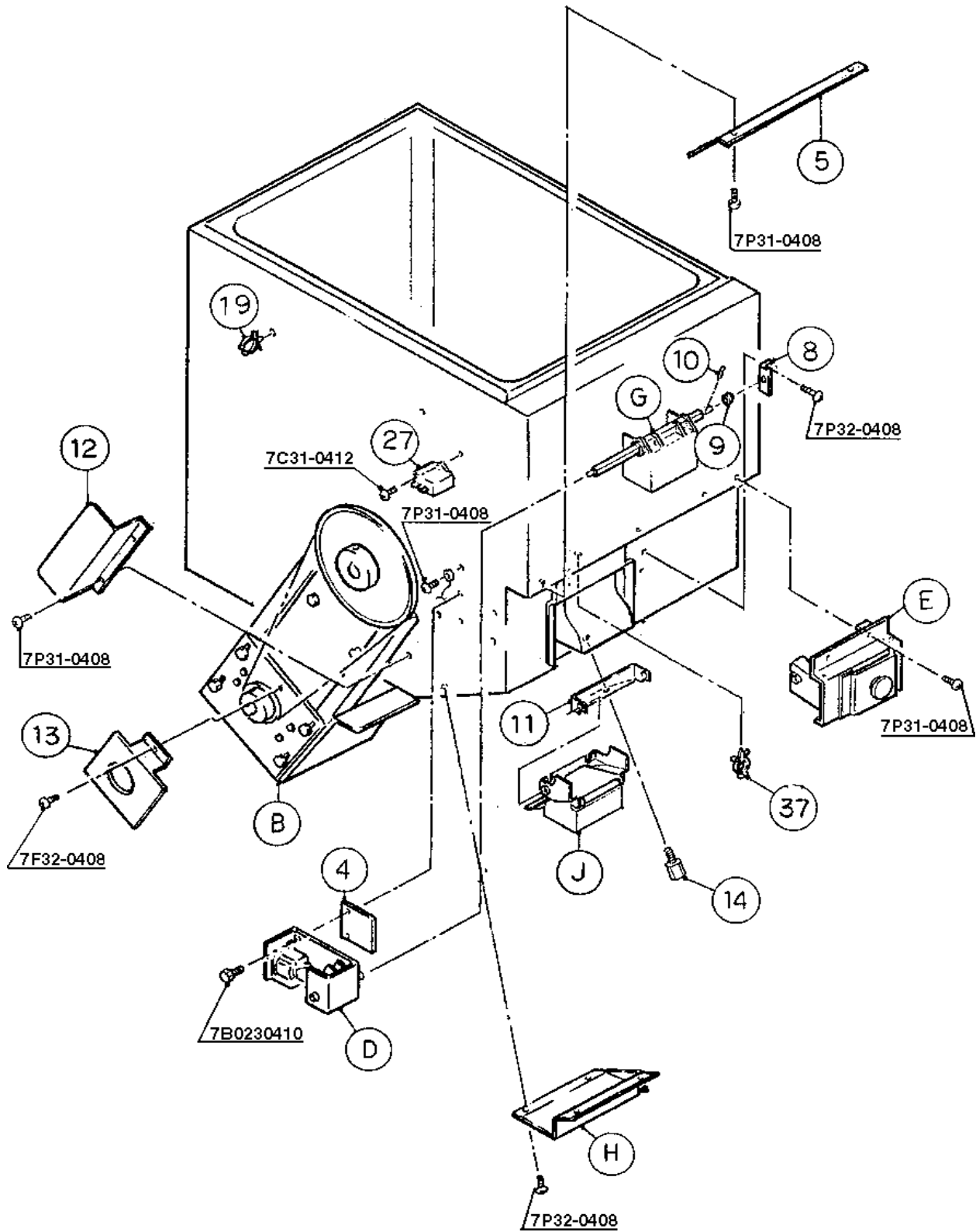

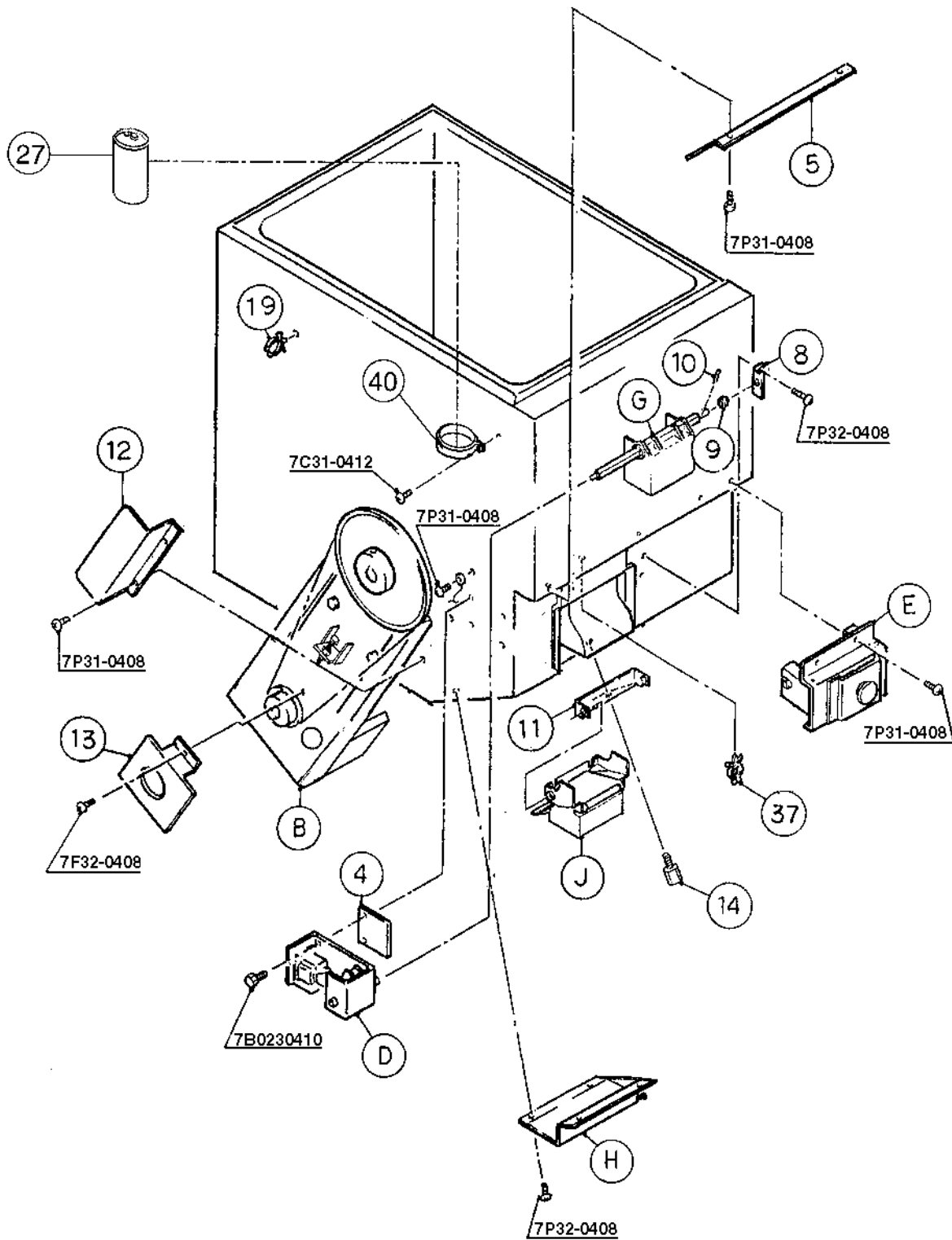

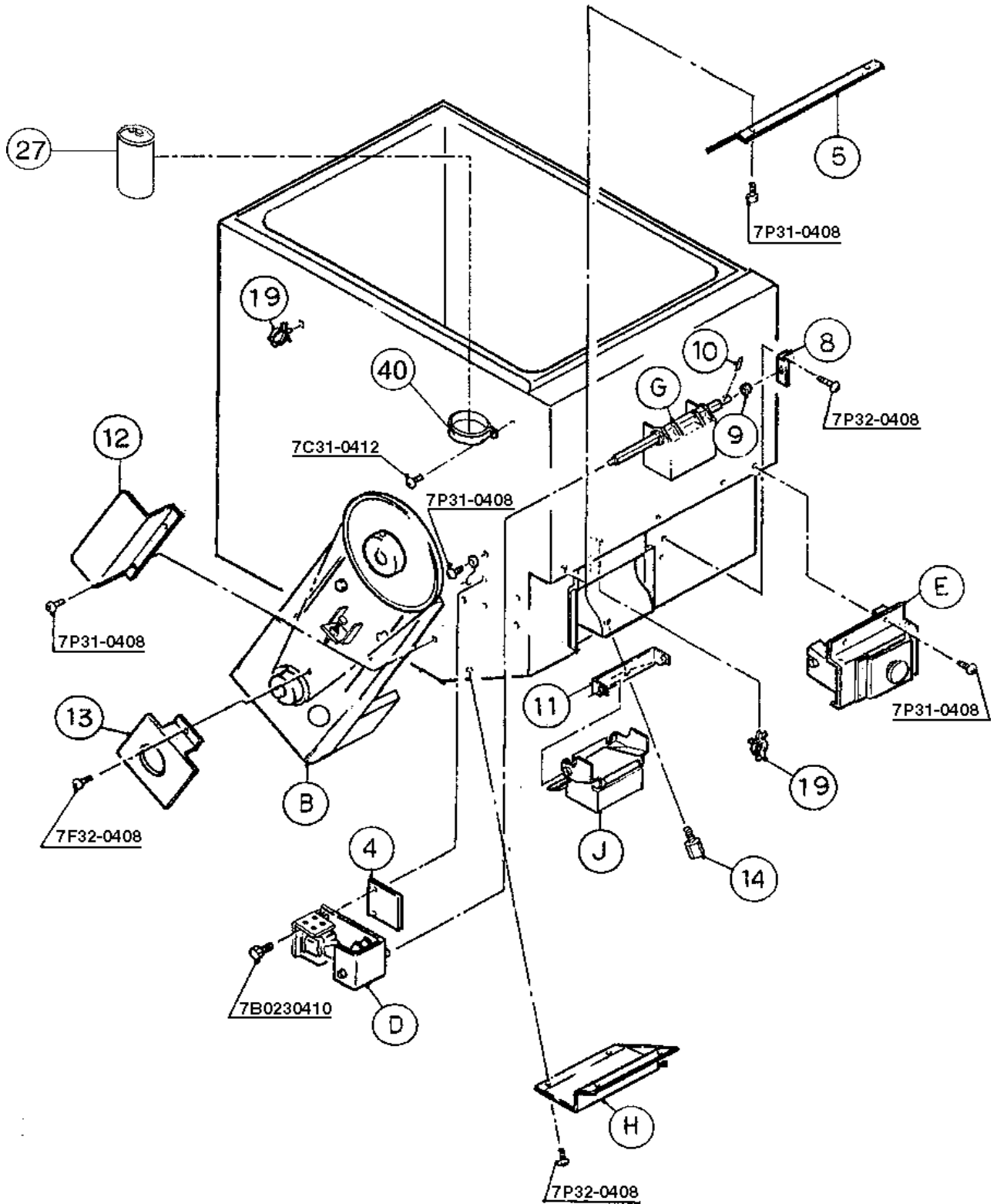

MODEL: DB-130C TITLE: A. DISPENSING BIN ASSEMBLY											
INDEX NO.	DESCRIPTION	MATERIAL OR MODEL NUMBER	PART NUMBER	REQUIRED NUMBER							
				K-1	B-1	All	C-1	D-2	F-1	G-0	K-0
				A-0	C-	C-0	D-0	E-0		H-0	L-0
				A-1	00290	above	D-1	F-0		J-0	
				B-0		C-					
						00291					
B	MECHANISM ASSEMBLY	-	104887A01	1	1	1	1	-			
		-	1A0110A01					1	1	1	1
C	CONTROL BOX ASSEMBLY	-	214613A01	1	1	1	-				
D	SOLENOID ASSEMBLY	-	214615A01	1	1	1	1	1	x1		
		-	2A0587A01						o1	1	1
E	SPOUT SWITCH ASSEMBLY	-	438021A01	1	1	1	1	1	1	1	1
F	DRAIN PAN ASSEMBLY	-	214616A01	1	-						
		-	214616A02		1	1	1	1	1	1	1
G	SHUTTER	-	326008A01	1	1	1	1	1	1	1	1
H	SAFETY SWITCH ASSEMBLY	-	438022A01	1	1	1	1	1	1	1	1
J	SPOUT	-	326007A01	1	1	1	1	1	1	1	1
K	LABEL LOCATION	-	324908A01	1	1	1	1	1	1	1	1
M	FRAME	-	3A0211A01				1	1	1	1	1
1	FRAME	GS	104882G01	1	1	1	-				
2	BIN BODY	-	104886G01	1	-						
		-	106185G01		1	1	1	1	1	1	1
3	FRAME (E)	GS	324886-01	1	1	1	1	1	1	1	1
4	SOLENOID ASSEMBLY BASE	GS	4A0048-01	1	1	1	1	1	1	1	1
5	BARRIER (A)	GS	324897-01	1	1	1	1	1	1	1	1

MODEL: DB-130C TITLE: A. DISPENSING BIN ASSEMBLY											
INDEX NO.	DESCRIPTION	MATERIAL OR MODEL NUMBER	PART NUMBER	REQUIRED NUMBER							
				K-1	B-1	C-1	D-2	F-1	G-0	K-0	L-0
				A-0	C-0	D-0	E-0		H-0		
				A-1		D-1	F-0		J-0		
				B-0							
6	PAD	ABS	436580-01	1	1	1	1	1	1	1	1
7	SUPPORTING PAD	PE FOAM	4A0040-01	1	1	1	1	1	1	1	1
8	COLLAR - BRACKET	GS	439399-01	1	1	1	1	1	1	1	1
9	COLLAR- SHUTTER	-	435533-01	1	1	1	1	1	1	1	1
10	SNAP PIN	SSP-6	715S-0006	1	1	1	1	1	1	1	1
11	HOOK	SS	439398-01	1	1	1	1	1	1	1	1
12	CHAIN COVER (A)	GS	438282-01	1	1	1	1	1	1	1	1
13	CHAIN COVER (B)	GS	438283-01	1	1	1	1	1	1	1	1
14	THUMBSCREW	ABS, SS	415949G01	4	4	4	4	4	4	2	2
15	CONTROL BOX (B)	GS	324901-01	1	1	1	1	1	1	1	1
16	CONTROL BOX (C)	GS	324902G01	1	1	1	1	1	1	1	1
17	CONTROL BOX (D)	GS	323808-01	1	1	1	1	1	1	1	1
18	BUSHING	OCB-750	428394-01	1	1	1	1	1	1	1	1
19	CLAMP	NO. 4253	427902-05	4	4	4	4	4	5	5	5
20	CABLE TIE	-	7920-003	1	1	1	1	1	1	1	1
21	SCREW - GROUNDING	BRASS	433304-02	1	1	1	1	1	1	1	1
22	SQUARE WASHER	COPPER	433537-02	1	1	1	1	1	1	1	1
23	BUSHING	SR-30-1	420472-03	1	1	1	1	1	1	1	1
24	JUNCTION BOX COVER	GS	433410-01	1	1	1	1	1	1	1	1
25	REAR PANEL	GS	324904-01	1	1	1	1	1	1	1	1
26	SIDE PANEL	GS	214489-02	2	2	2	2	2	2	2	2
27	CAPACITOR	12MFD SH-JPSU	435648-01	1	1	1	-				
		25MFD 370VAC	439943-02				1	1	1	1	1
28	BRACKET - FRONT PANEL (A)	SS	324905-01	1	1	1	1	1	1	1	1

MODEL: DB-130C TITLE: A. DISPENSING BIN ASSEMBLY											
INDEX NO.	DESCRIPTION	MATERIAL OR MODEL NUMBER	PART NUMBER	REQUIRED NUMBER							
				K-1	B-1	All	C-1	D-2	G-0	K-0	L-0
				A-0	C-	C-0	D-0	E-0	H-0		
				A-1	00290	above	D-1	F-0	J-0		
				B-0		C-		F-1			
						00291					
29	BRACKET - FRONT PANEL (B)	SS	324710-01	1	1	1	1	1	1	1	1
30	SEAL (REAR)	PVC	4A0055-03	1	1	1	1	1	x2		
	GASKET	L=418	4A0808L01						o2	2	2
31	SEAL (FRONT)	PVC	4A0056-02	1	1	1	1	1	-		
32	SEAL (SIDE)	PVC	4A0055-02	1	1	1	1	1	-		
33	FRONT PANEL	ABS	214618G01	1	1	1	1	1	1	x1	
		-	214618G02							o1	1
34	DRAIN BOARD	ABS	324906G01	1	1	1	1	1	1	-	
		ABS	3A1656G01							1	1
35	BRACKET - DRAIN BOARD	SS	4A0044-01	2	2	2	2	2	2	2	2
36	SEAL	PVC	4A0056-03	1	1	1	1	1	-		
37	CLAMP	NO. 826	427902-01		1	1	1	1	-		
38	BRACKET - FRONT PANEL (C)	GS	4A0143-01			2	-				
		GS	4A0334-01				2	2	4	4	4
39	CONTROL BOX (A)	GS	214614-01				1	1	1	1	1
40	STRAP	GS	4A0506-01					1	1	1	1
41	GASKET	L=660	4A0808L01						2	2	2
42	VINYL HOSE	L=445	7716-2025	1	1	1	1	1	1	1	1
43	HOOK (R)	-	4A0104-01	1	1	-					
44	HOOK (L)	-	4A0105-01	1	1	-					

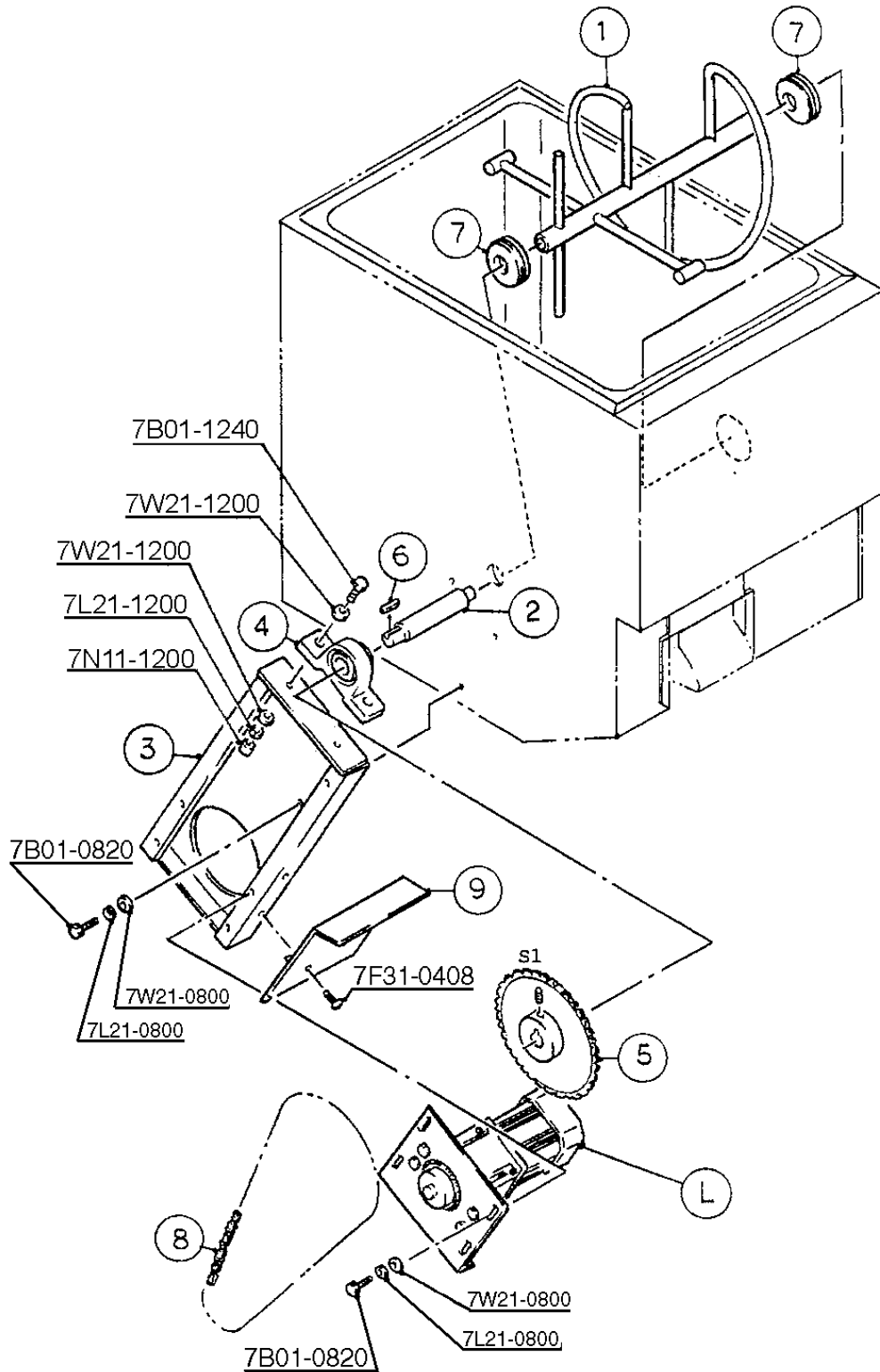

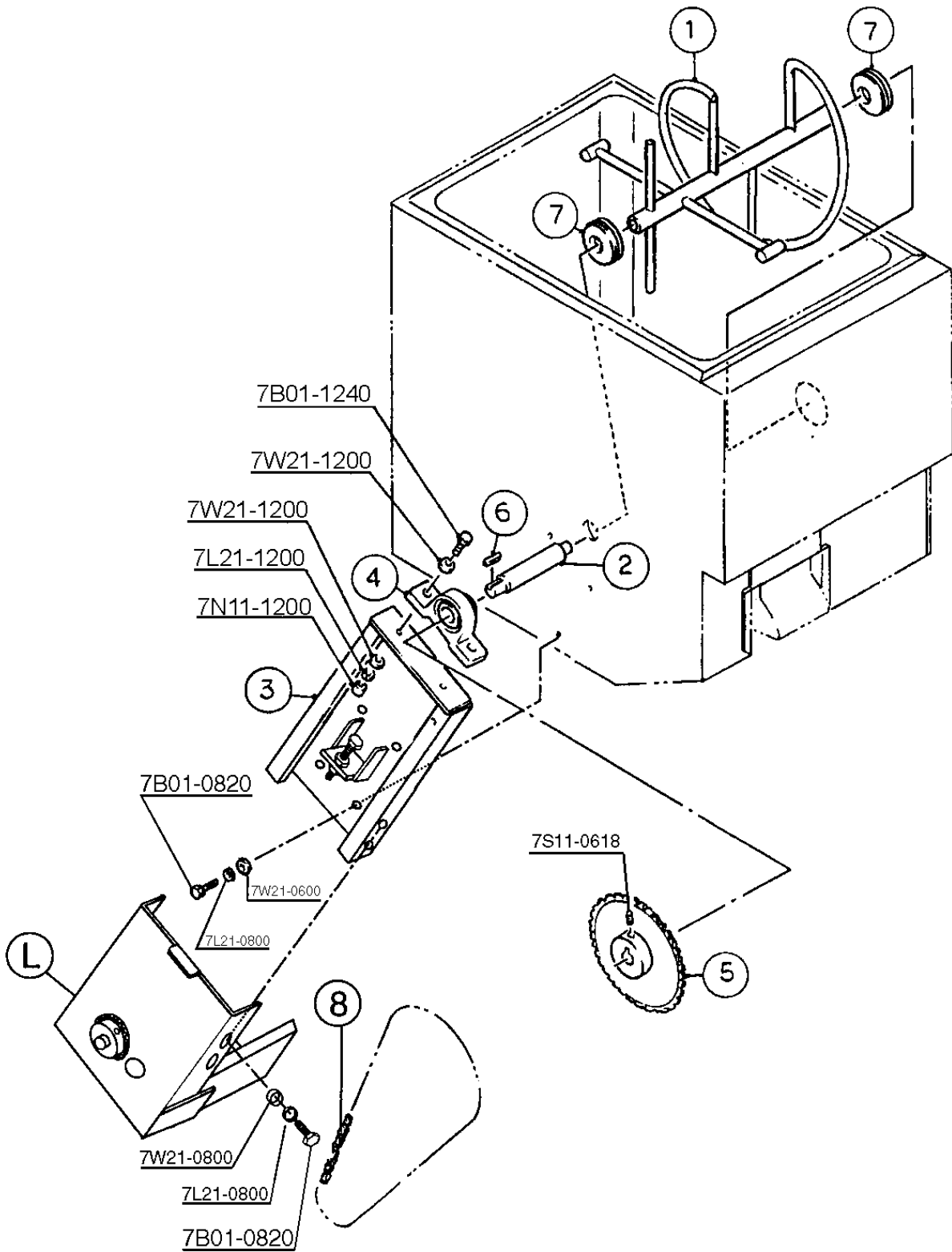

MODEL: DB-130C TITLE: B. MECHANISM ASSEMBLY											
INDEX NO.	DESCRIPTION	MATERIAL OR MODEL NUMBER	PART NUMBER	REQUIRED NUMBER							
				K-1	B-1	C-1	D-2	F-1	G-0	K-0	L-0
				A-0	C-0	D-0	E-0		H-0		
				A-1		D-1	F-0		J-0		
B-0											
L	GEAR MOTOR ASSEMBLY	-	212971A01	1	1	1	-				
		-	2A0443A02				1	1	1	1	1
1	AGITATOR	SS	324892G01	1	1	1	1	1	1	1	1
2	DRIVE SHAFT	SS	437928-01	1	1	1	1	1	1	1	1
3	GEAR MOTOR BRACKET (A)	GS	212970G01	1	1	1	-				
		GS	2A0450G01				1	1	1	1	1
4	PILLOW	UCP-205G000	435553-02	1	1	1	1	1	1	1	1
5	SPROCKET (B)	NO. 35x65	435554-01	1	1	1	1	1	1	1	1
6	KEY	6x6x22	437265-01	1	1	1	1	1	1	1	1
7	SEAL (B)	EPDM	435558-01	2	2	2	2	2	2	2	2
8	CHAIN	RK35 130RINK	435797-01	1	1	1	1	1	1	1	1
9	BARRIER	GS	324894-01	1	1	1	-				

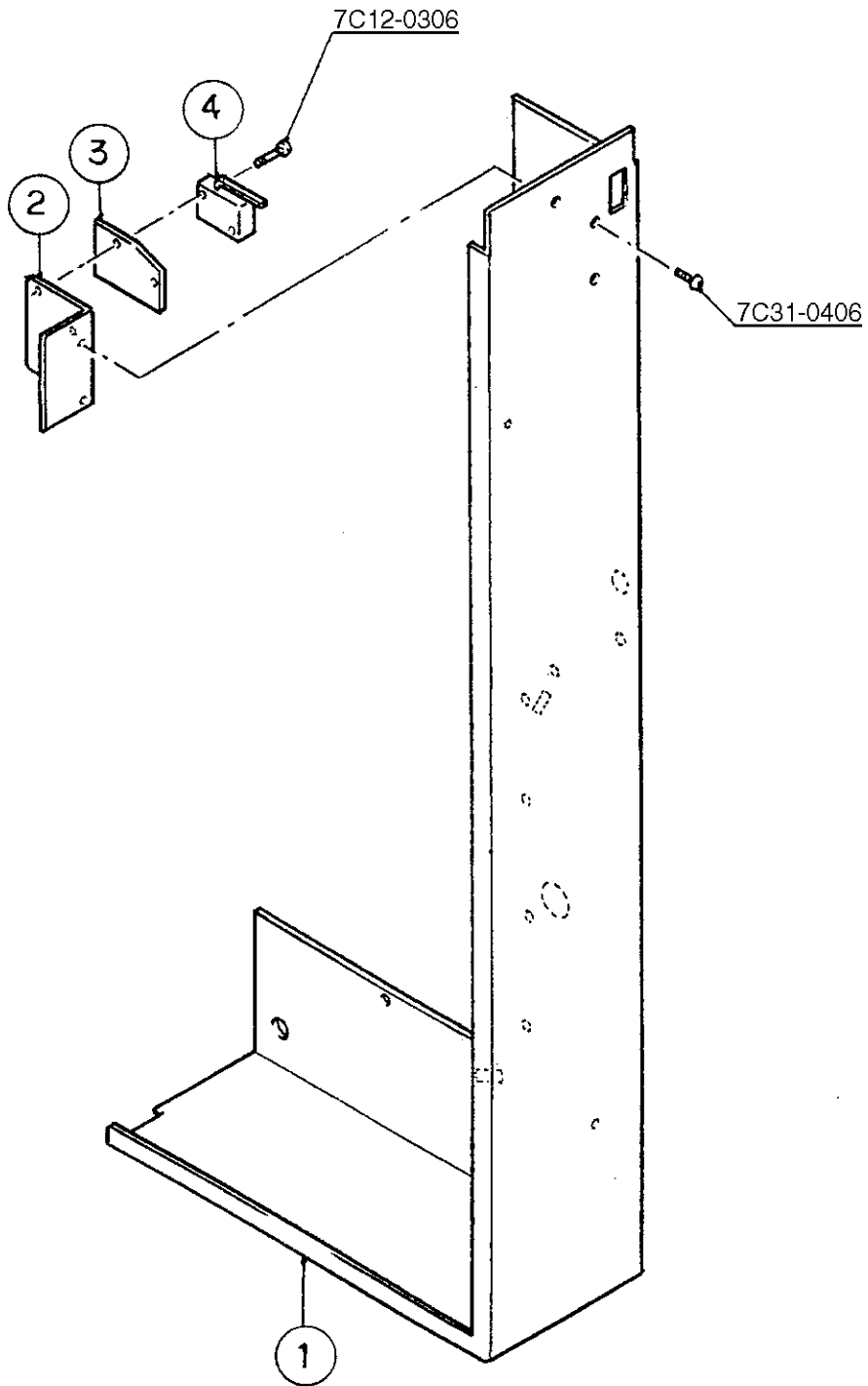

HA
DB-130C

D. SOLENOID ASSEMBLY

K-1, A-0, A-1, B-0, B-1, C-0,
C-1, D-0, D-1, D-2, E-0, F-0

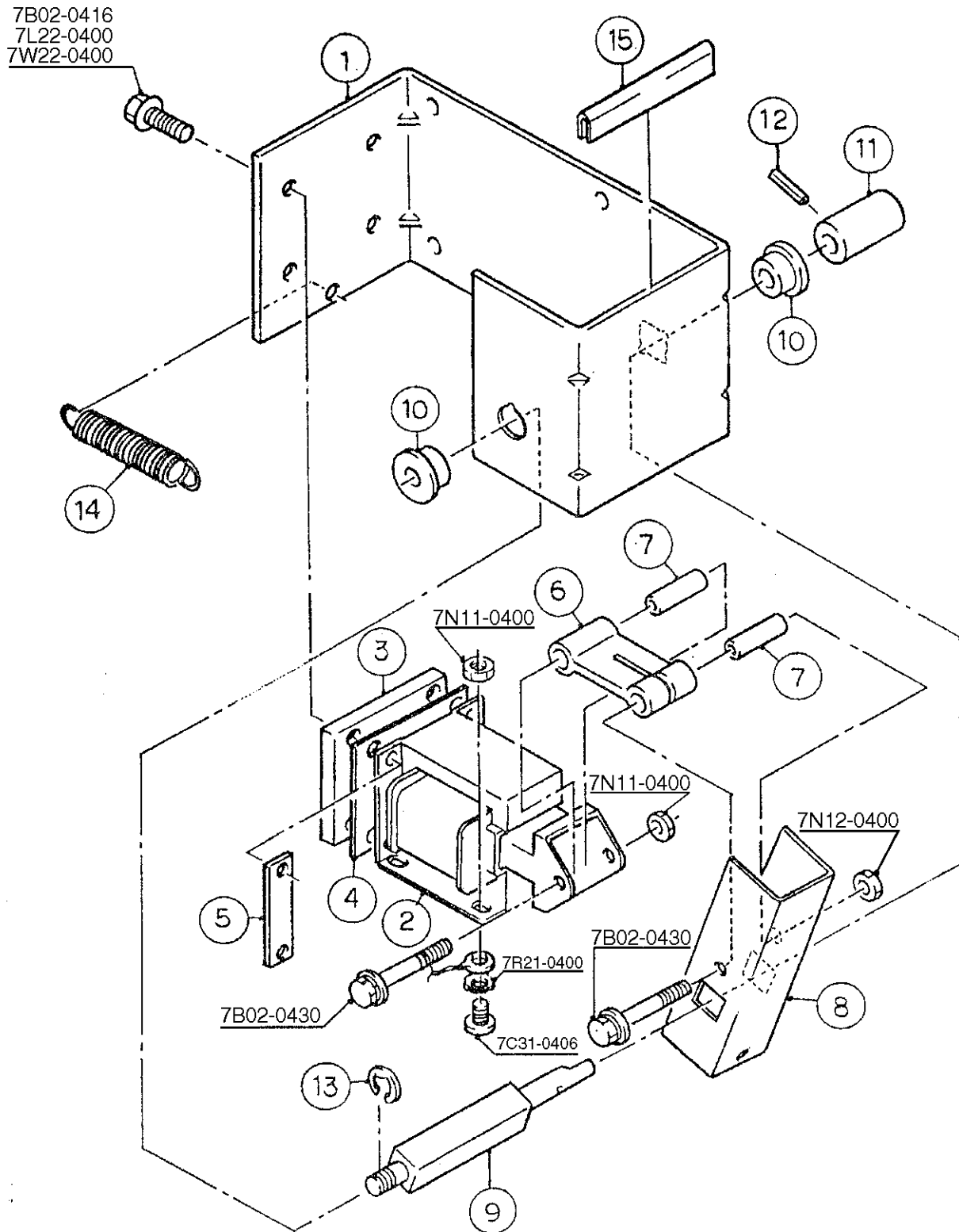

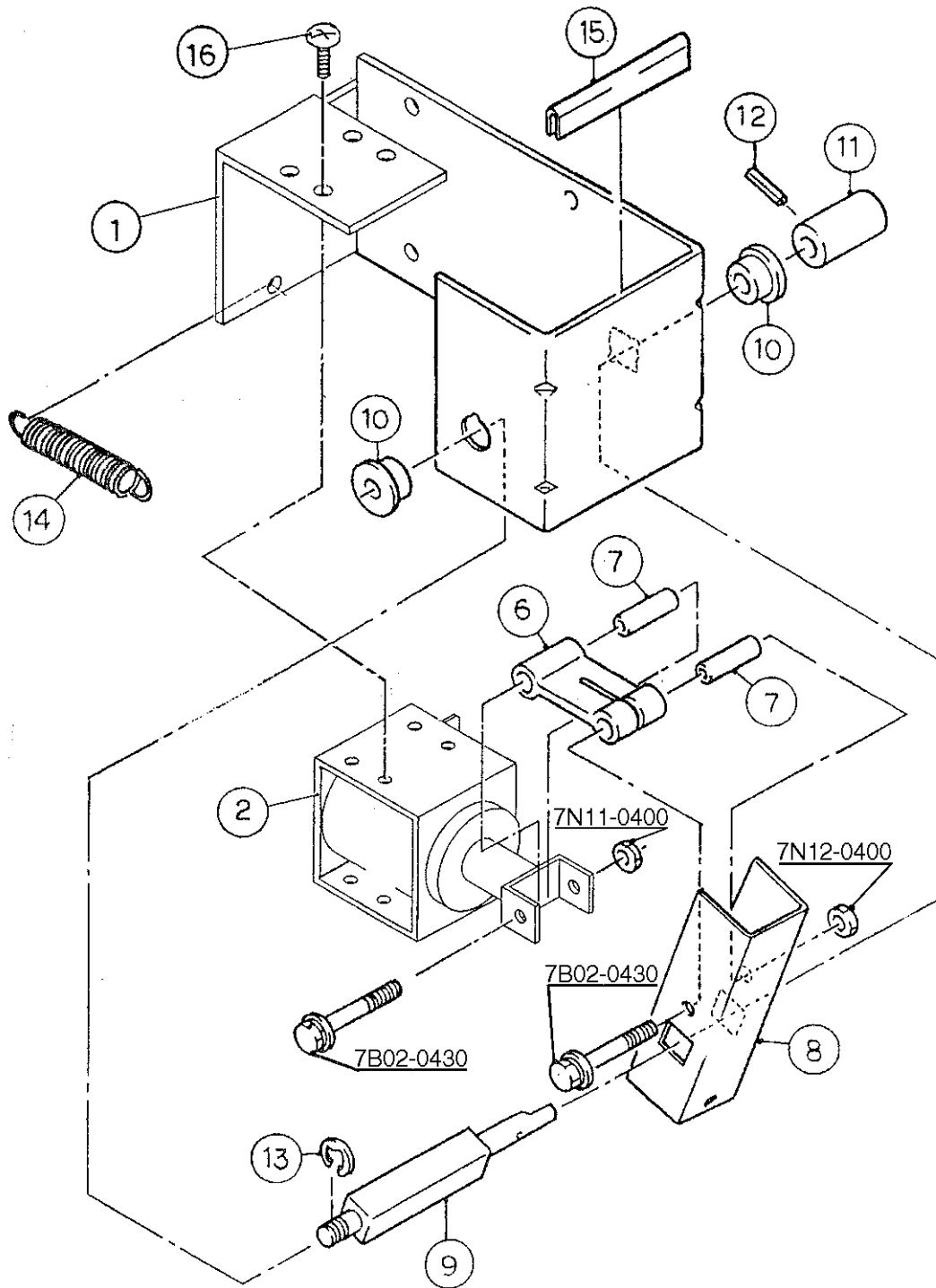

MODEL: DB-130C TITLE: D. SOLENOID ASSEMBLY											
INDEX NO.	DESCRIPTION	MATERIAL OR MODEL NUMBER	PART NUMBER	REQUIRED NUMBER							
				K-1	B-1	C-1	D-2	F-1	G-0	K-0	L-0
				A-0	C-0	D-0	E-0		H-0		
				A-1		D-1	F-0		J-0		
B-0											
1	SOLENOID BRACKET	GS	324700-01	1	1	1	1	x1			
		GS	3A0534-01					o1	1	1	1
2	SOLENOID	AS-04-A117	3U0095-01	1	1	1	1	x1			
		S0071-E	4A0856-01					o1	1	1	1
3	SOLENOID PACKING	NEOPRENE RUBBER	430380-01	1	1	1	1	-			
4	PACKING COVER	SS	431623-02	1	1	1	1	-			
5	SOLENOID NUT	SS	429723-02	2	2	2	2	-			
6	LINK	POLYOXY-METHYLENE	432232-01	1	1	1	1	1	1	1	1
7	COLLAR (D)	SS	432471-01	2	2	2	2	1	2	2	1
8	LINK SOLENOID	GS	439397-01	1	1	1	1	1	1	1	1
9	SHAFT	SS	435532-01	1	1	1	1	1	1	1	1
10	COLLAR - SHUTTER	POLYOXY-METHYLENE	435533-01	2	2	2	2	2	2	2	2
11	CONNECTOR	SS	435534-01	1	1	1	1	1	1	1	1
12	SPRING PIN	SS 3x12	712S-0312	1	1	1	1	1	1	1	1
13	"E" RING	SS 5	721S-0005	1	1	1	1	1	1	1	1
14	SPRING	SS	432878-01	1	1	1	1	1	1	1	1
15	RUBBER GASKET	CH-35	4A0662L01	1	1	1	1	1	1	1	1
16	SCREW, TRUSS HEAD	SS	7C32-0416					4	4	4	4

HA
DB-130C

E. SPOUT SWITCH ASSEMBLY

K-1, A-0, A-1, B-0, B-1, C-0,
C-1, D-0, D-1, D-2, E-0, F-0,
F-1, G-0, H-0, J-0, K-0, L-0

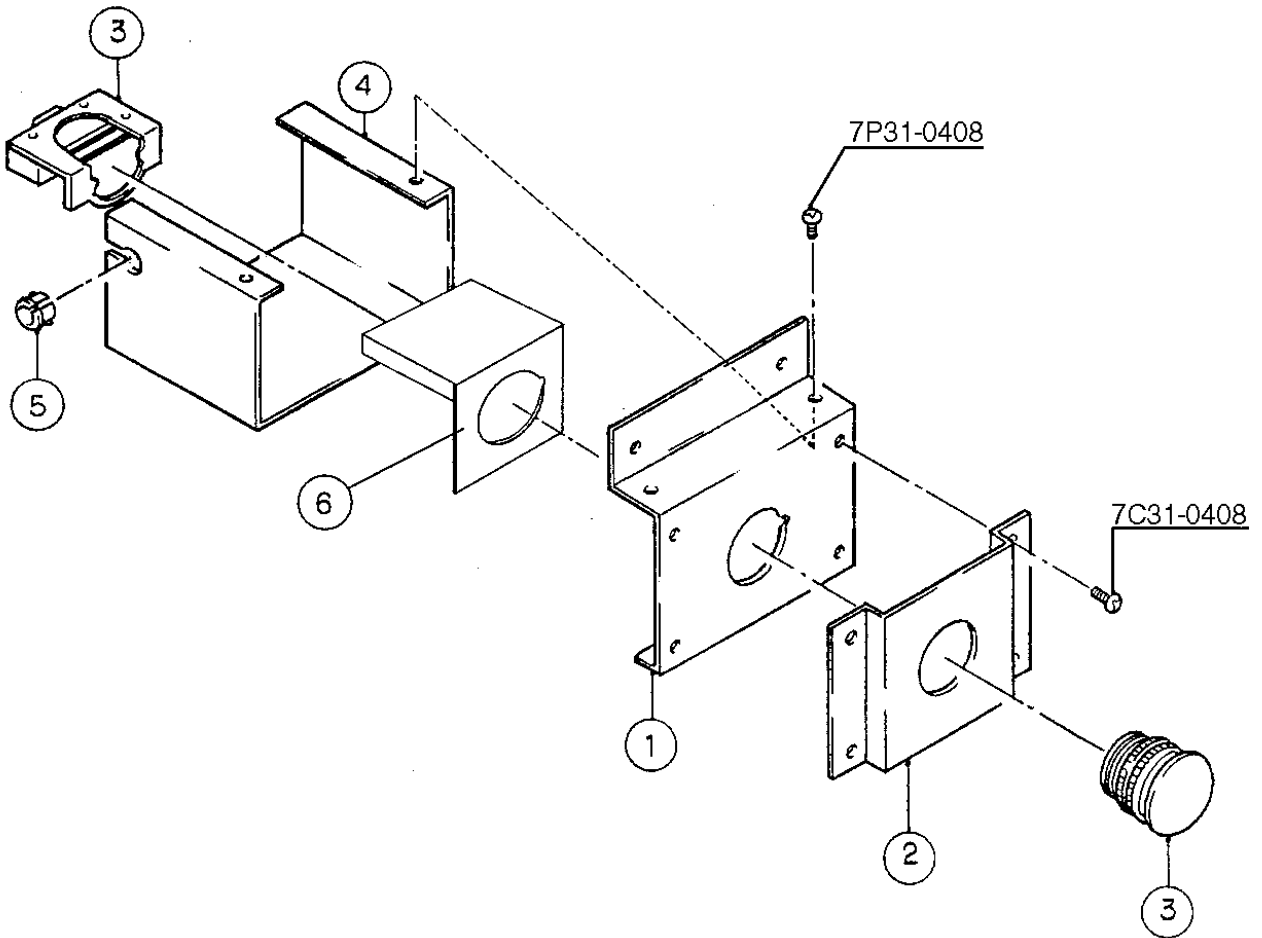

HA
DB-130C

F. DRAIN PAN ASSEMBLY

K-1, A-0, A-1, B-0, B-1, C-0,
C-1, D-0, D-1, D-2, E-0, F-0,
F-1, G-0, H-0, J-0, K-0, L-0

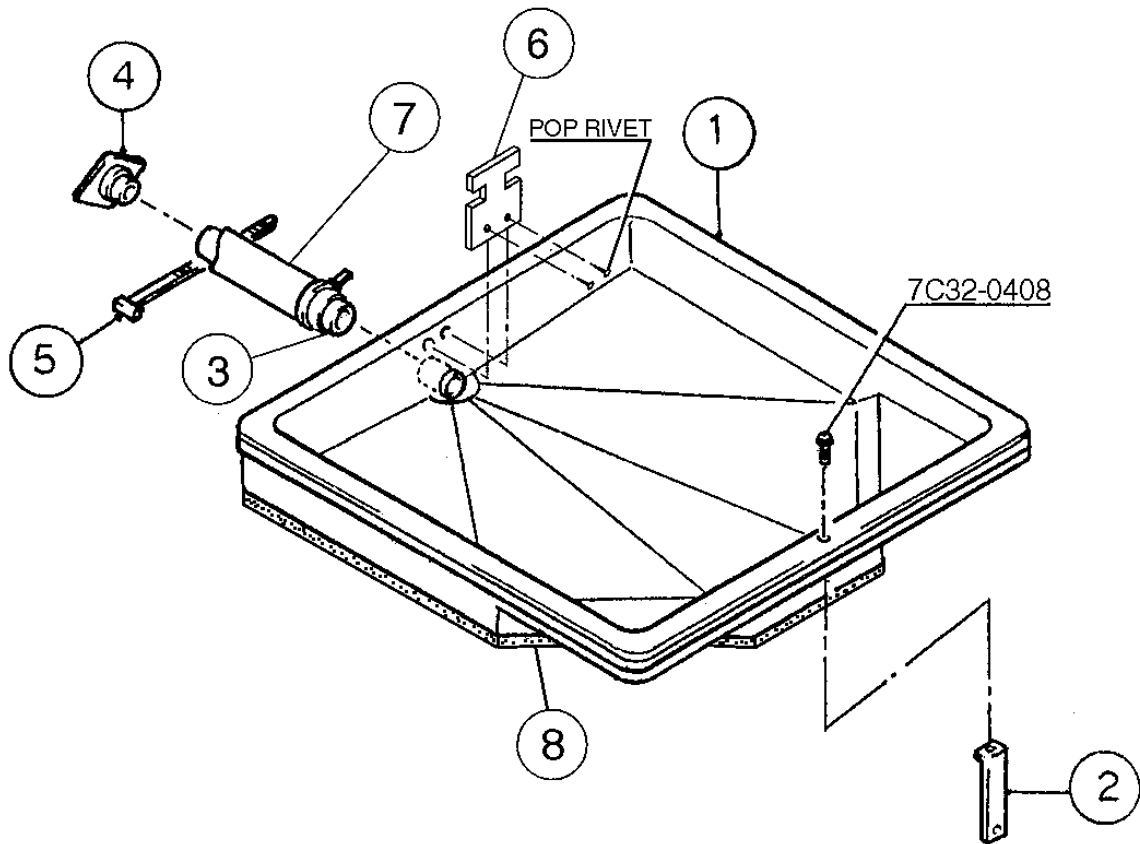

HA
DB-130C

G. SHUTTER

K-1, A-0, A-1, B-0, B-1, C-0,
C-1, D-0, D-1, D-2, E-0, F-0,
F-1, G-0, H-0, J-0, K-0, L-0

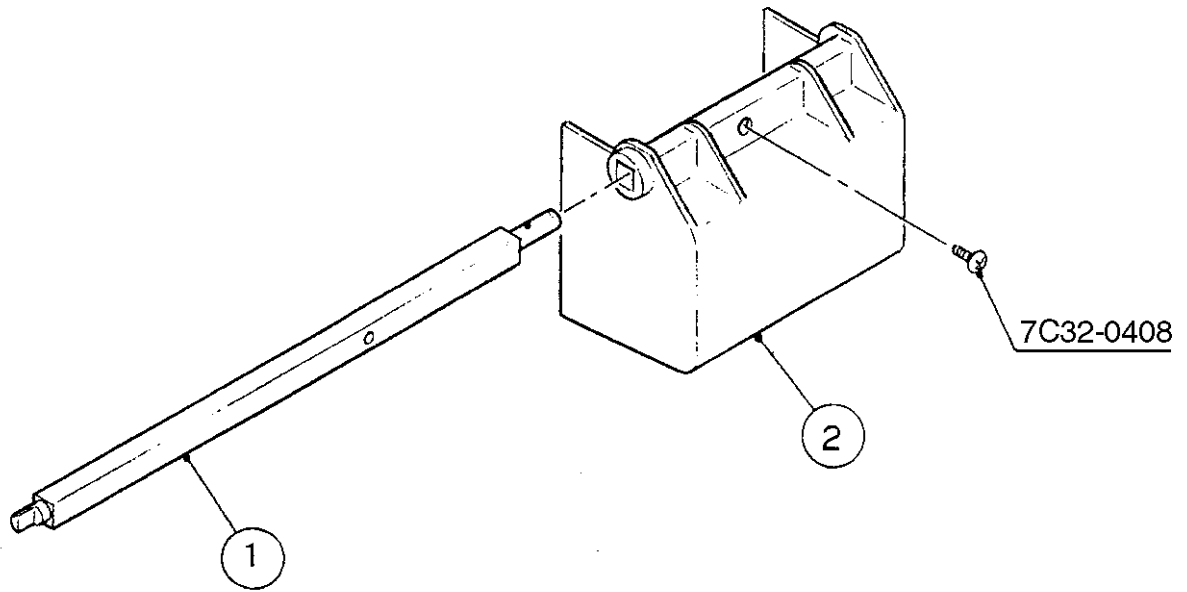

HA
DB-130C

H. SAFETY SWITCH ASSEMBLY

K-1, A-0, A-1, B-0, B-1, C-0,
C-1, D-0, D-1, D-2, E-0, F-0,
F-1, G-0, H-0, J-0, K-0, L-0

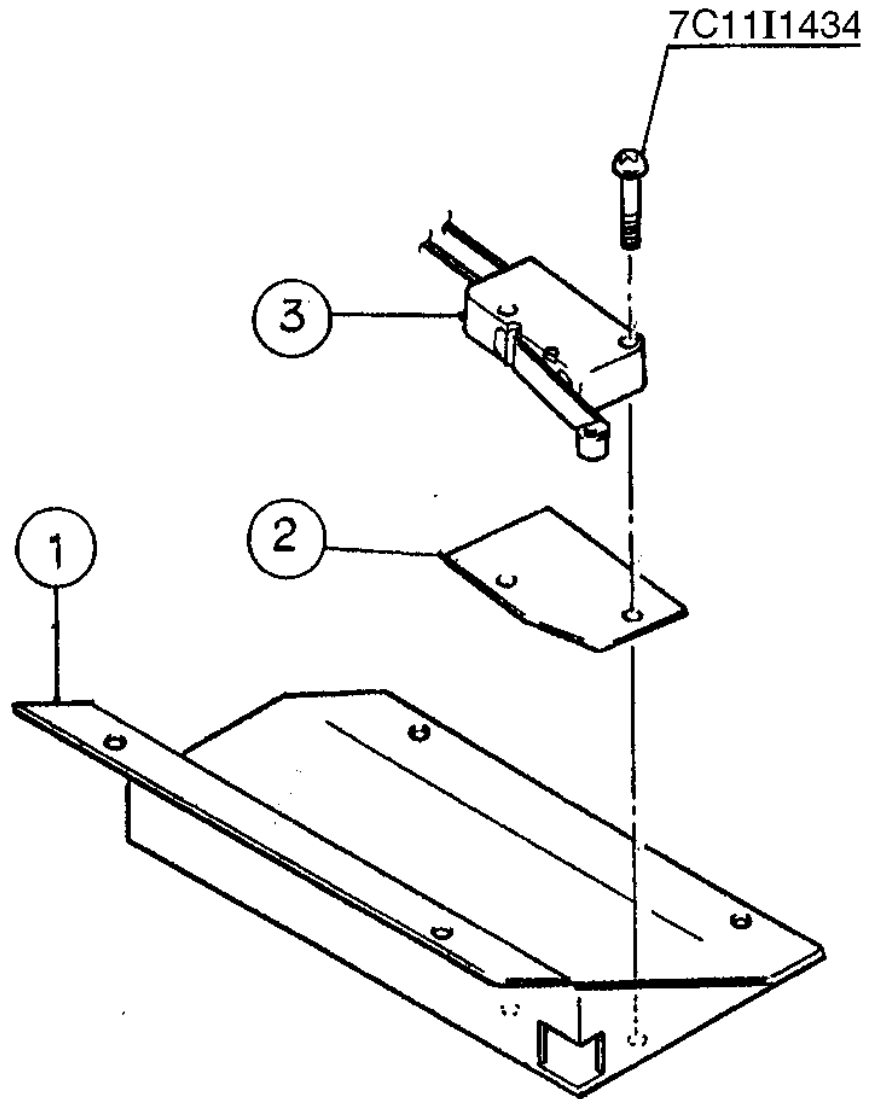

HA
DB-130C

J. SPOUT

K-1, A-0, A-1, B-0, B-1, C-0,
C-1, D-0, D-1, D-2, E-0, F-0,
F-1, G-0, H-0, J-0, K-0, L-0

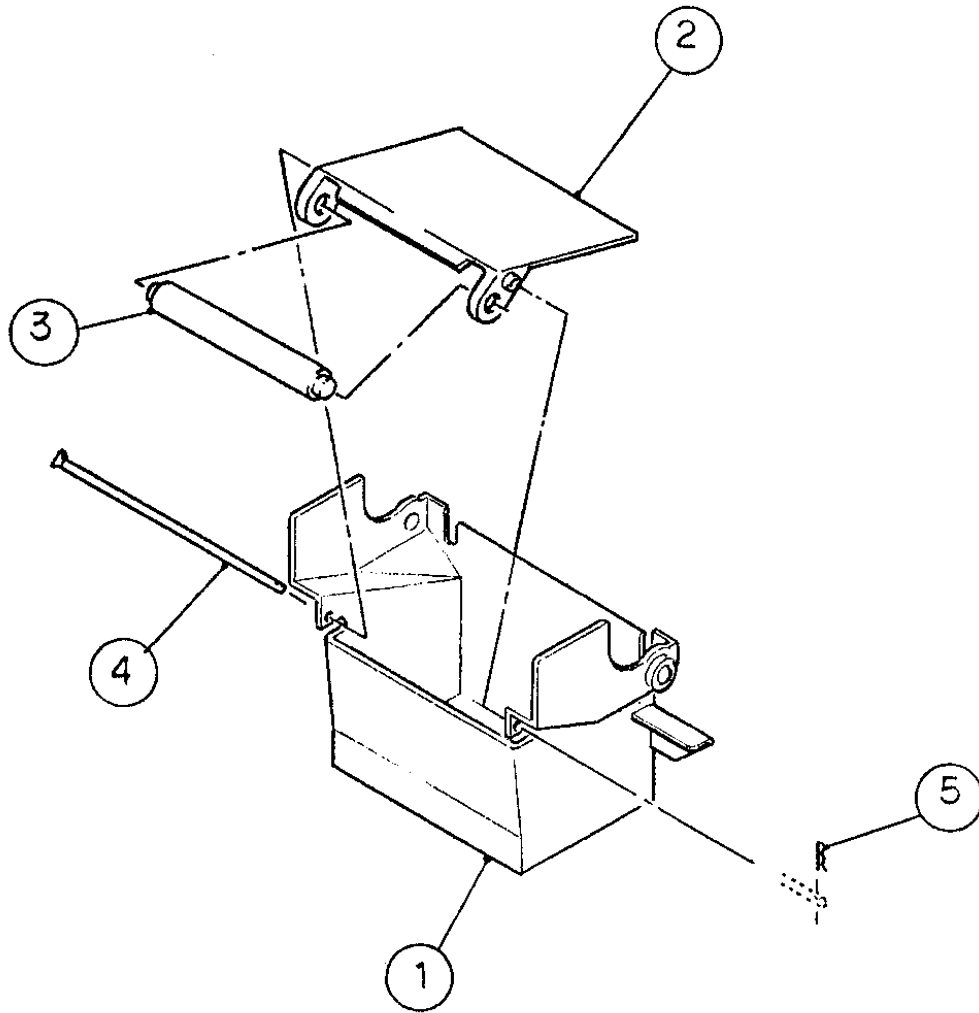

HA
DB-130C

K. LABEL LOCATION

K-1, A-0, A-1, B-0, B-1, C-0,
C-1, D-0, D-1, D-2, E-0, F-0,
F-1, G-0, H-0, J-0, K-0, L-0

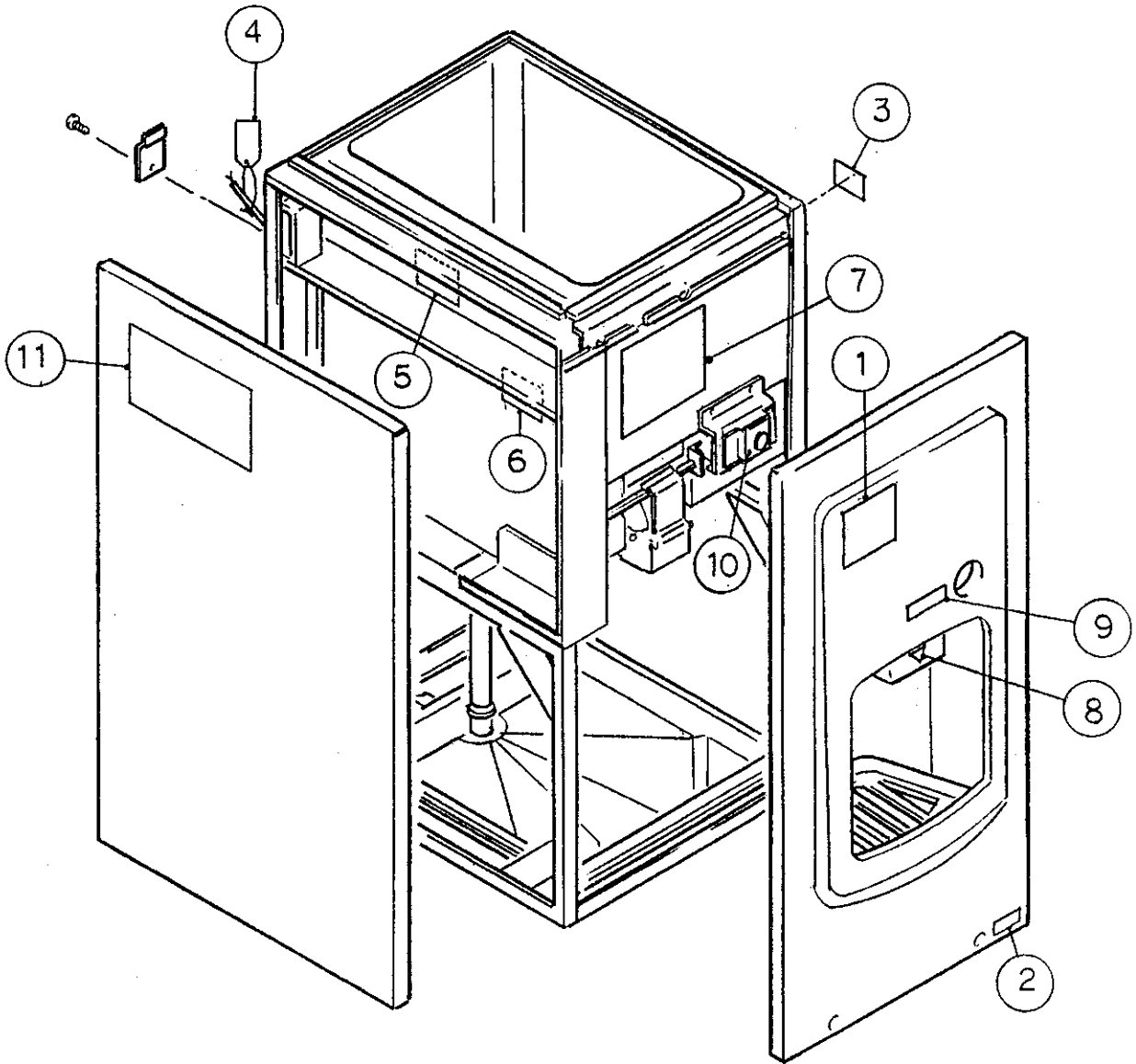

MODEL: DB-130C TITLE: K. LABEL LOCATION												
INDEX NO.	DESCRIPTION	MATERIAL OR MODEL NUMBER	PART NUMBER	REQUIRED NUMBER								
				K-1	A-0 A-1 B-0 B-1 C-0	C-1 D-0	D-1	D-2 E-0 F-0 F-1	G-0 H-0 J-0	K-0	L-0	
1	NAMING LABEL	PVC FILM	323207-01	1	1	1	1	1	1	1	1	1
2	MODEL NUMBER LABEL	PVC FILM	438597-01	1	1	1	1	1	1	1	1	1
3	NAMEPLATE	PES FILM	438598-01	1	-							
		PES FILM	440399-01		1	1	-					
		PES FILM	4A0501-01				1	1	1	1	1	1
4	TAG-WARNING: ELECTRICAL CONNECTION	PAPER	435005-01	1	1	1	1	1	1	1	1	1
5	WIRING LABEL	PVC FILM	325113-01	1	1	-						
		PVC FILM	329550-01			1	1	-				
		PVC FILM	3A0404-01					1	1	1	1	1
6	WARNING LABEL	PVC FILM	438599-01	1	1	-						
7	MAINTENANCE LABEL	PVC FILM	218264-01	1	1	1	1	1	1	1	1	1
8	LABEL - ICE	PVC FILM	436091-01	1	1	1	1	1	1	1	1	1
9	LABEL - SPOUT SWITCH	PVC FILM	435757-01	1	1	1	1	1	1	1	1	1
10	LABEL - COLOR	PETP FILM	435758-01	1	1	1	1	1	1	1	1	1
11	INSTRUCTION SHEET	PAPER	218268-01	1	1	1	1	1	1	1	1	1

L. GEAR MOTOR ASSEMBLY

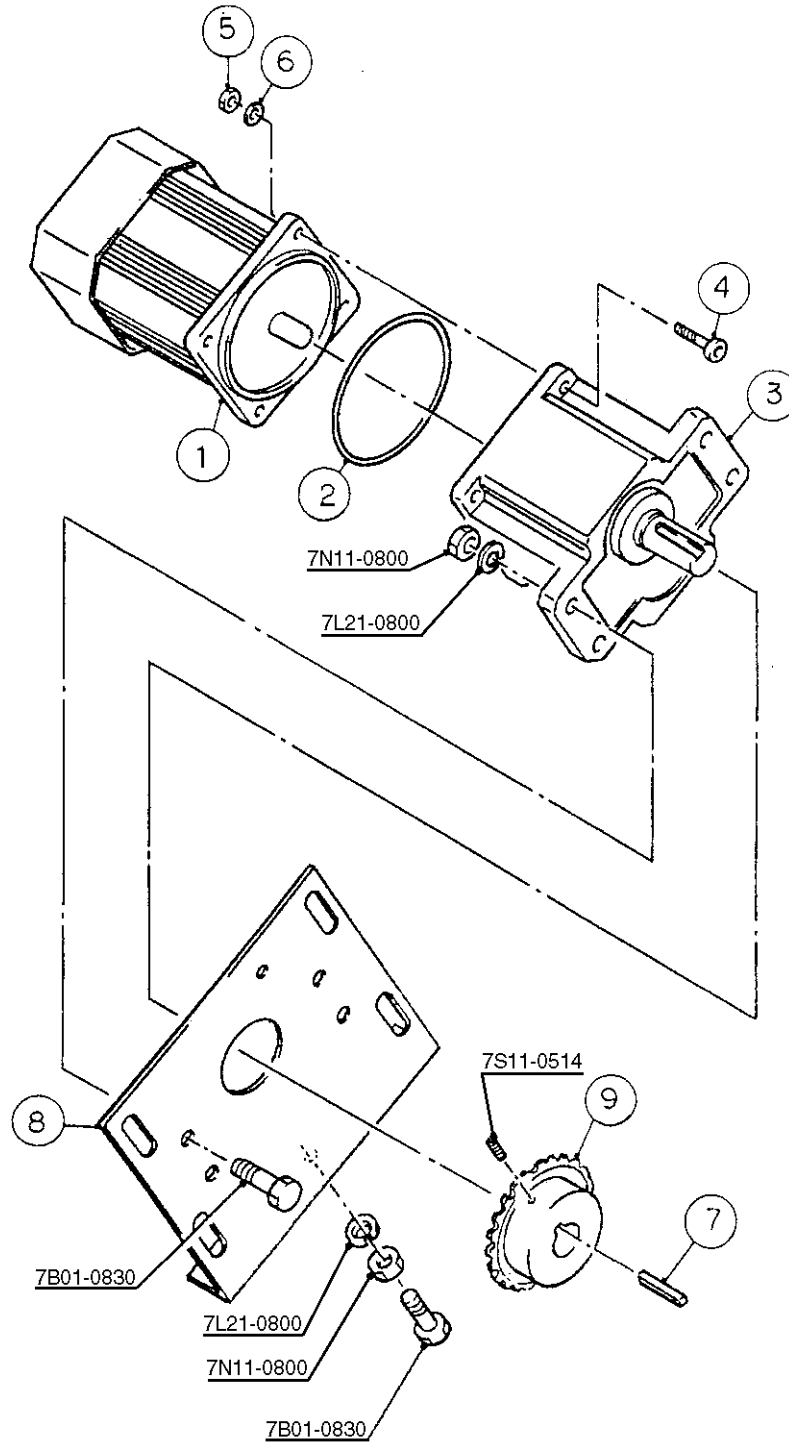

L. GEAR MOTOR ASSEMBLY

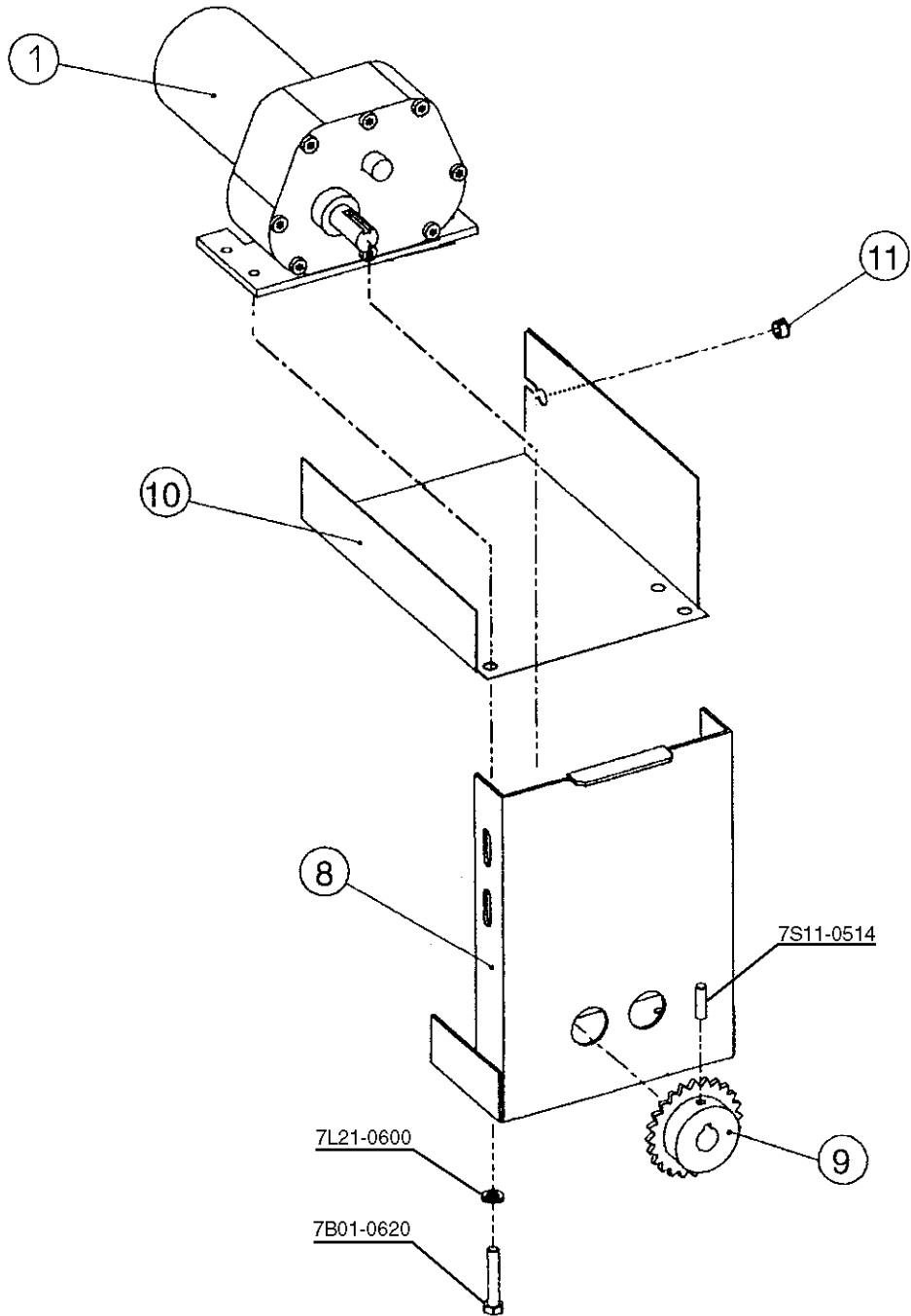

MODEL: DB-130C TITLE: L. GEAR MOTOR ASSEMBLY											
INDEX NO.	DESCRIPTION	MATERIAL OR MODEL NUMBER	PART NUMBER	REQUIRED NUMBER							
				K-1	B-1	C-1	D-2	F-1	G-0	K-0	L-0
				A-0	C-0	D-0	E-0		H-0		
				A-1		D-1	F-0		J-0		
1	GEAR MOTOR	M91C60G4DU	323055-01	1	1	1	-				
		V06695AB84	4A0183-01				1	1	1	1	1
2	"O" RING	RUBBER	323055F01	1	1	1	-				
3	GEAR MOTOR HEAD	M9GS120B	323056-01	1	1	1	-				
4	SOCKET HEAD CAP SCREW	M6x25	323056F01	4	4	4	-				
5	HEX NUT	M6	323056F02	4	4	4	-				
6	FLAT WASHER	M6	323056F03	4	4	4	-				
7	KEY	S45C	323056F04	1	1	1	-				
8	GEAR MTR. BRCKT. (B)	GS	435556G01	1	1	1	-				
		GS	2A0123-01				1	1	1	1	1
9	SPROCKET (A)	NO. 35x24	435557-01	1	1	1	1	1	1	1	1
10	BARRIER (C)	GS	3A0398-01				1	1	1	1	1
11	BUSHING	0CB-500	428394-02				1	1	1	1	1

HA
DB-130C

M. FRAME

C-1, D-0, D-1, D-2, E-0, F-0,
F-1, G-0, H-0, J-0, K-0, L-0

