

NO: 71012

ISSUED: SEPT. 6, 1989

REVISED: FEB. 25, 2002



**HOSHIZAKI
ICE DISPENSING BIN**

MODEL

DB-200C

(FINAL) PARTS LIST

J-1	JULY 1989
J-2	OCTOBER 1989
K-1	DECEMBER 1989
K-2	SEPTEMBER 1990
A-0	MARCH 1991
A-1	NOVEMBER 1991
B-0	FEBRUARY 1992
B-1	APRIL 1992
B-2	MAY 1992
C-0	FEBRUARY 1993
C-1	MARCH 1993
D-0	DECEMBER 1993
D-1	SEPTEMBER 1994
E-0	DECEMBER 1994
F-0	DECEMBER 1995
F-1	MARCH 1996
G-0	DECEMBER 1996
H-0	DECEMBER 1997
J-0	DECEMBER 1998
K-0	DECEMBER 1999
L-0	DECEMBER 2000

MATERIAL ABBREVIATIONS

ALUMINUM

AL = Aluminum

COPPER

CU = Copper

PLASTIC

ABS = Acrylonitrile -butadiene - styrene
AC = Polyacetal
EVA = Ethylene vinyl acetate
PA = Polyamide = Nylon
PC = Polycarbonate
PE = Polyethylene
PES = Polyester
PETP = Polyethylene terephthalate = Tetlon
PP = Polypropylene
PS = Polystyrene
PTFE = Polytetrafluoroethylene = Teflon
PUR = Polyurethane
PVC = Polyvinyl chloride

RUBBER

VN = Vinyl Nitrile
EPDM = EP rubber
NBR = Nitrile butadiene rubber
NR = Natural rubber
NP = Neoprene
SI.R = Silicone rubber
SY.R = Synthetic rubber
EPH = Epichlorohydrin

STEEL

GS = Galvanized steel
SS = Stainless steel
PS = Plated steel
PAS = Primed steel

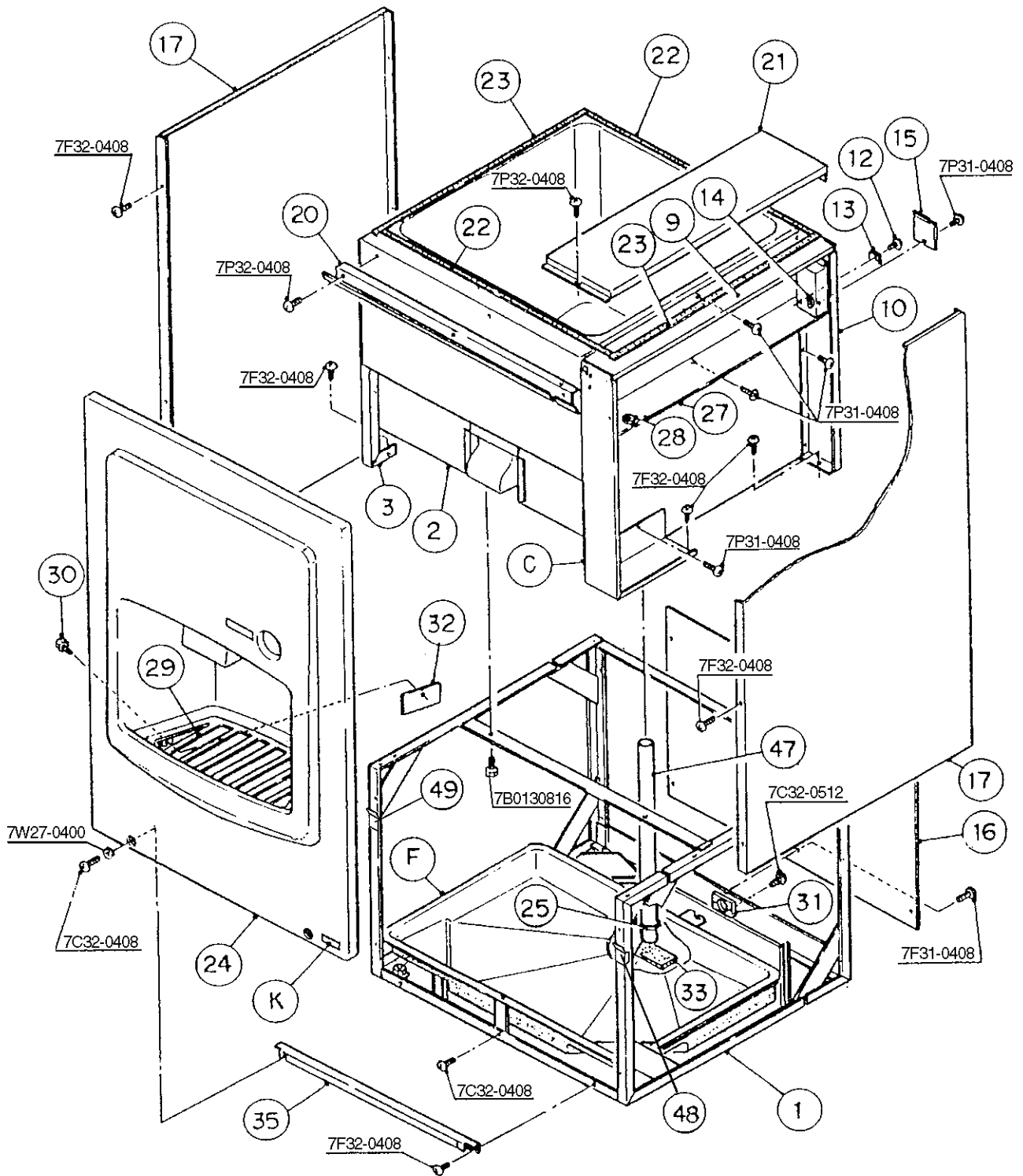

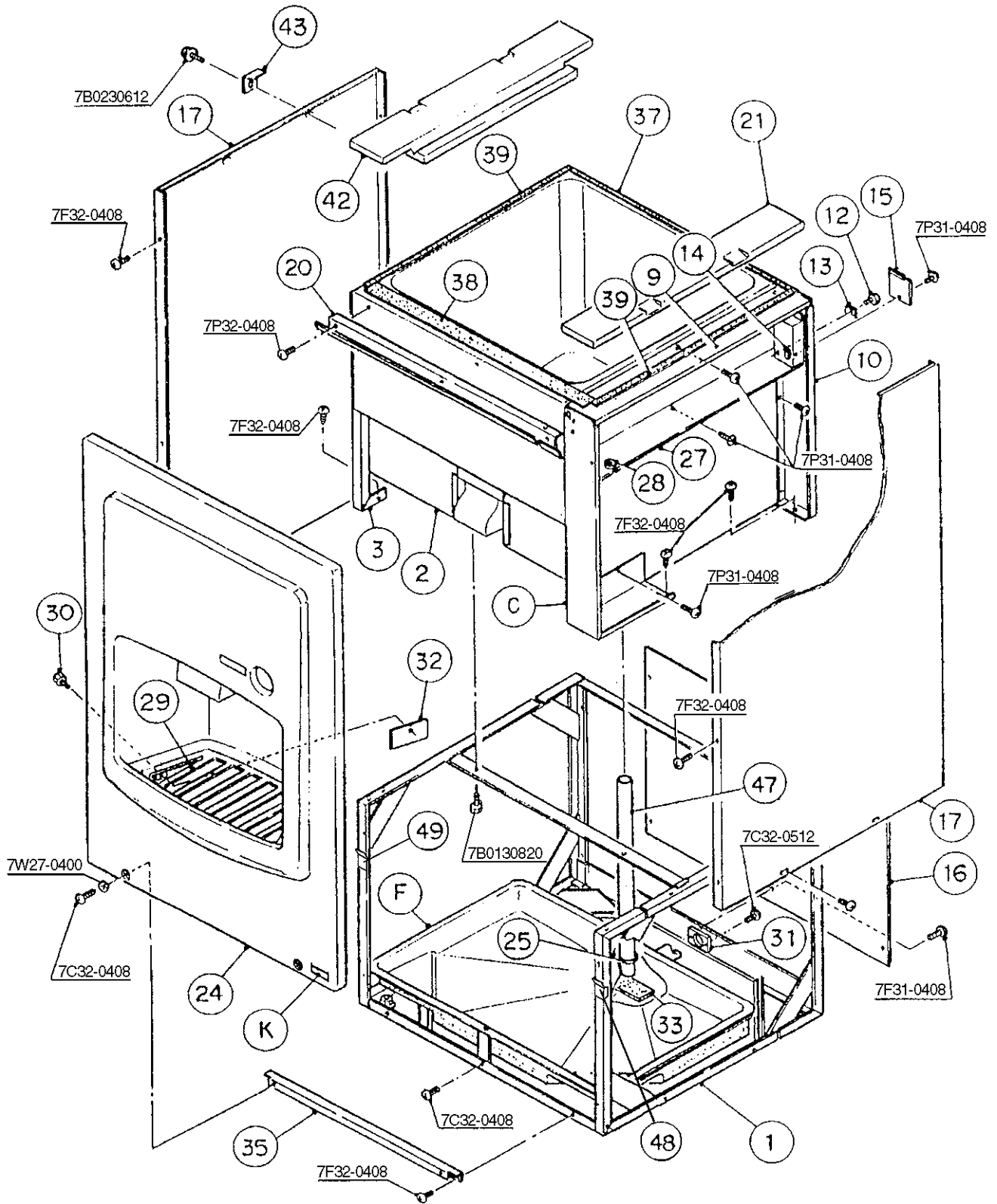

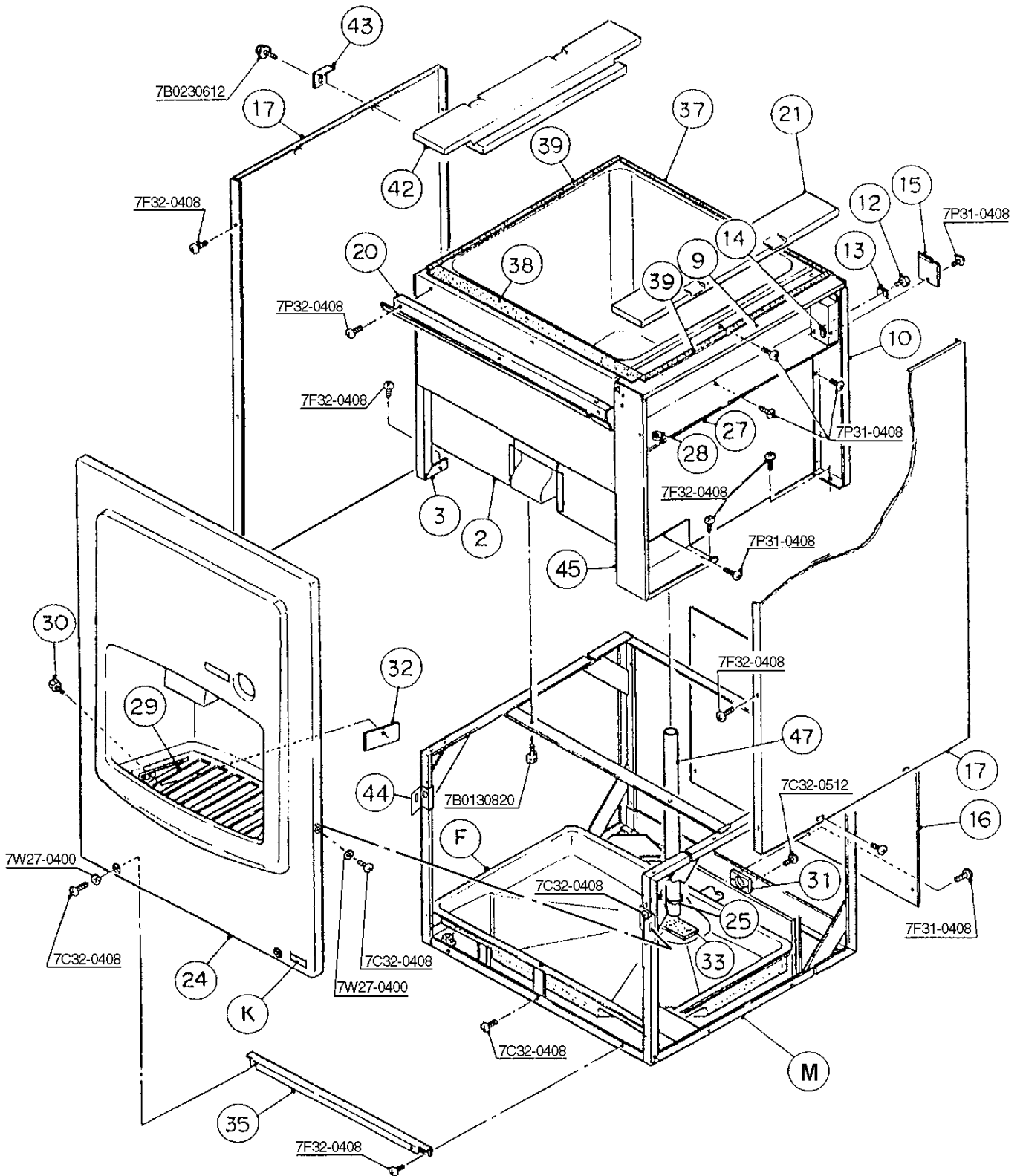

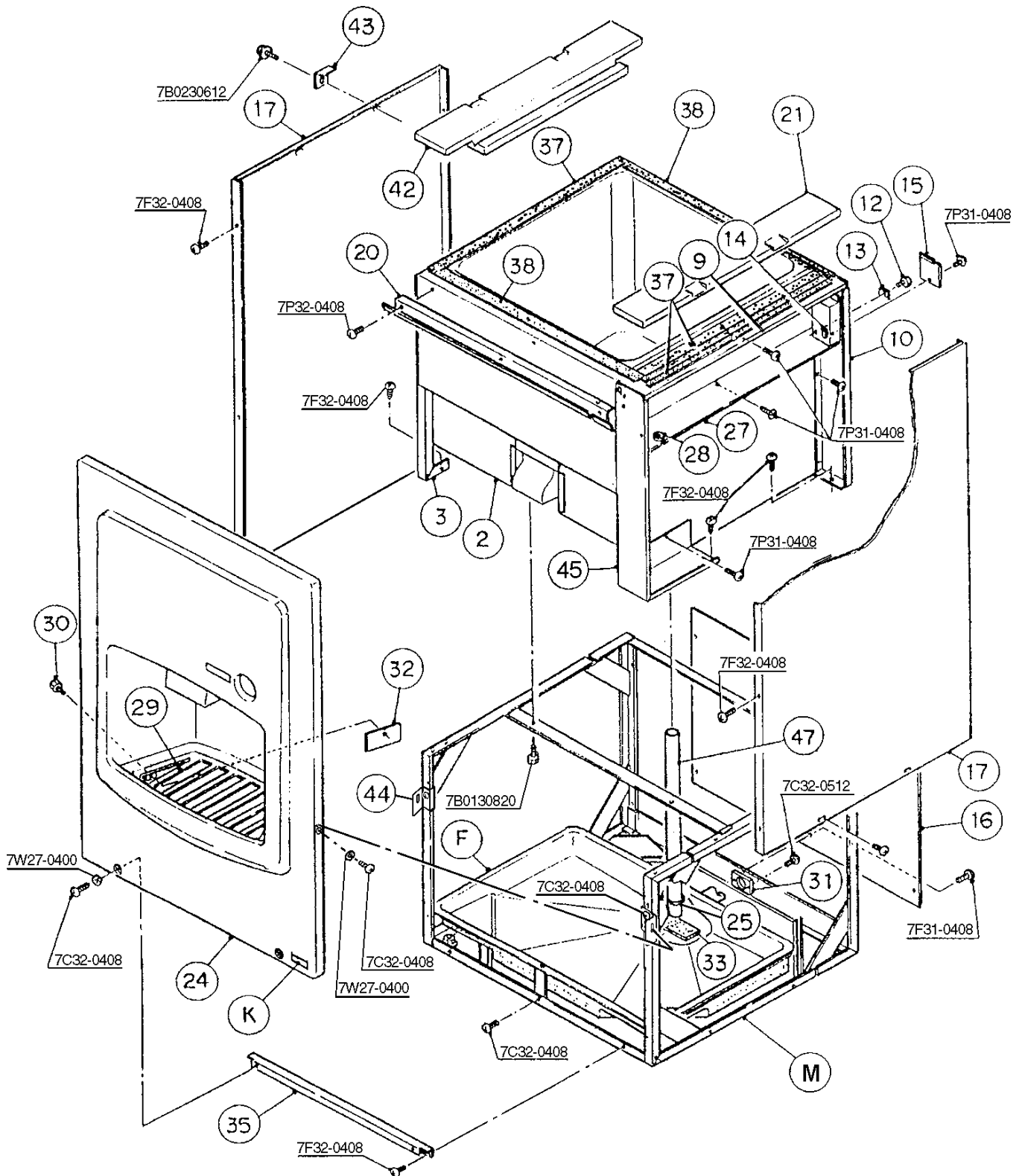

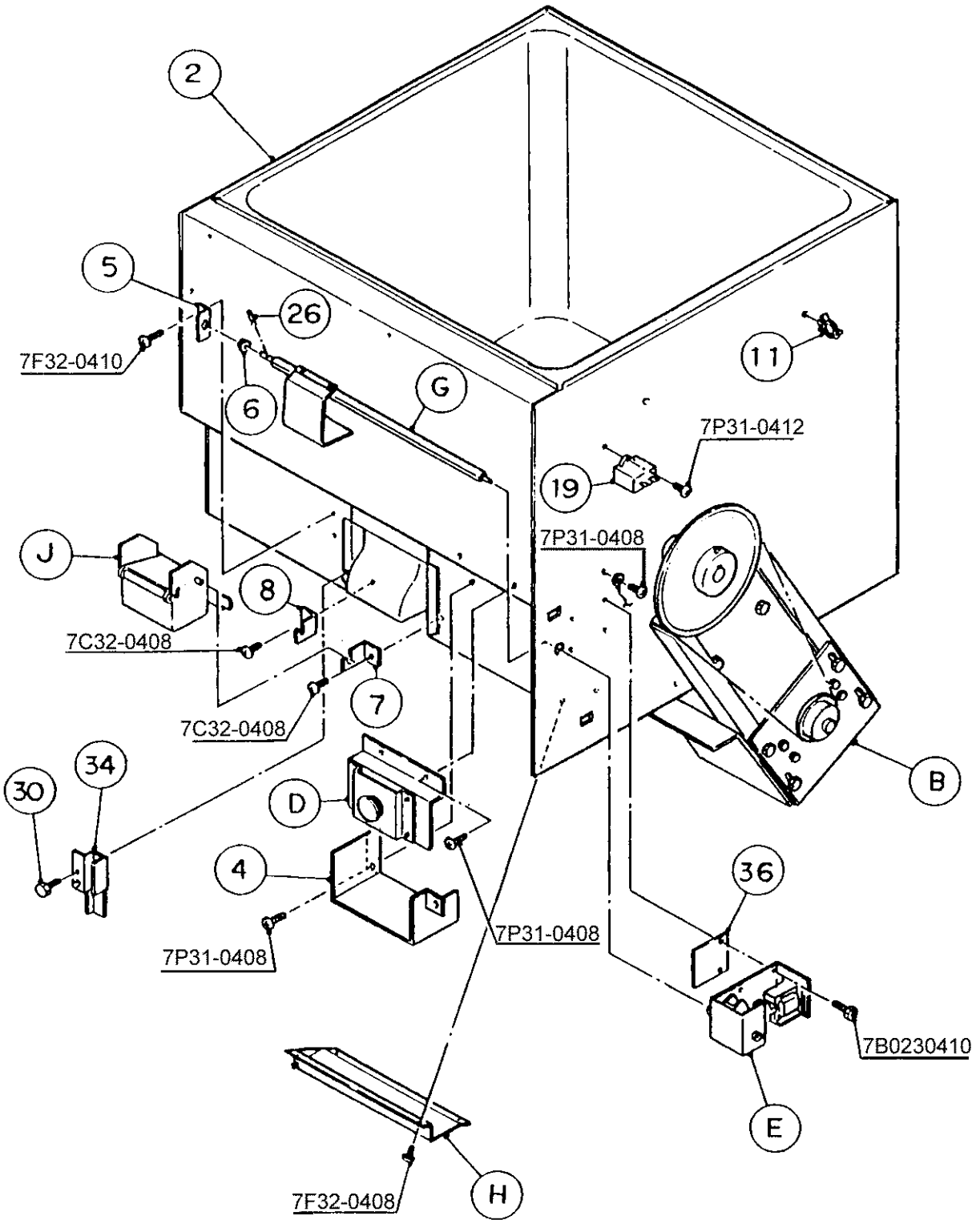

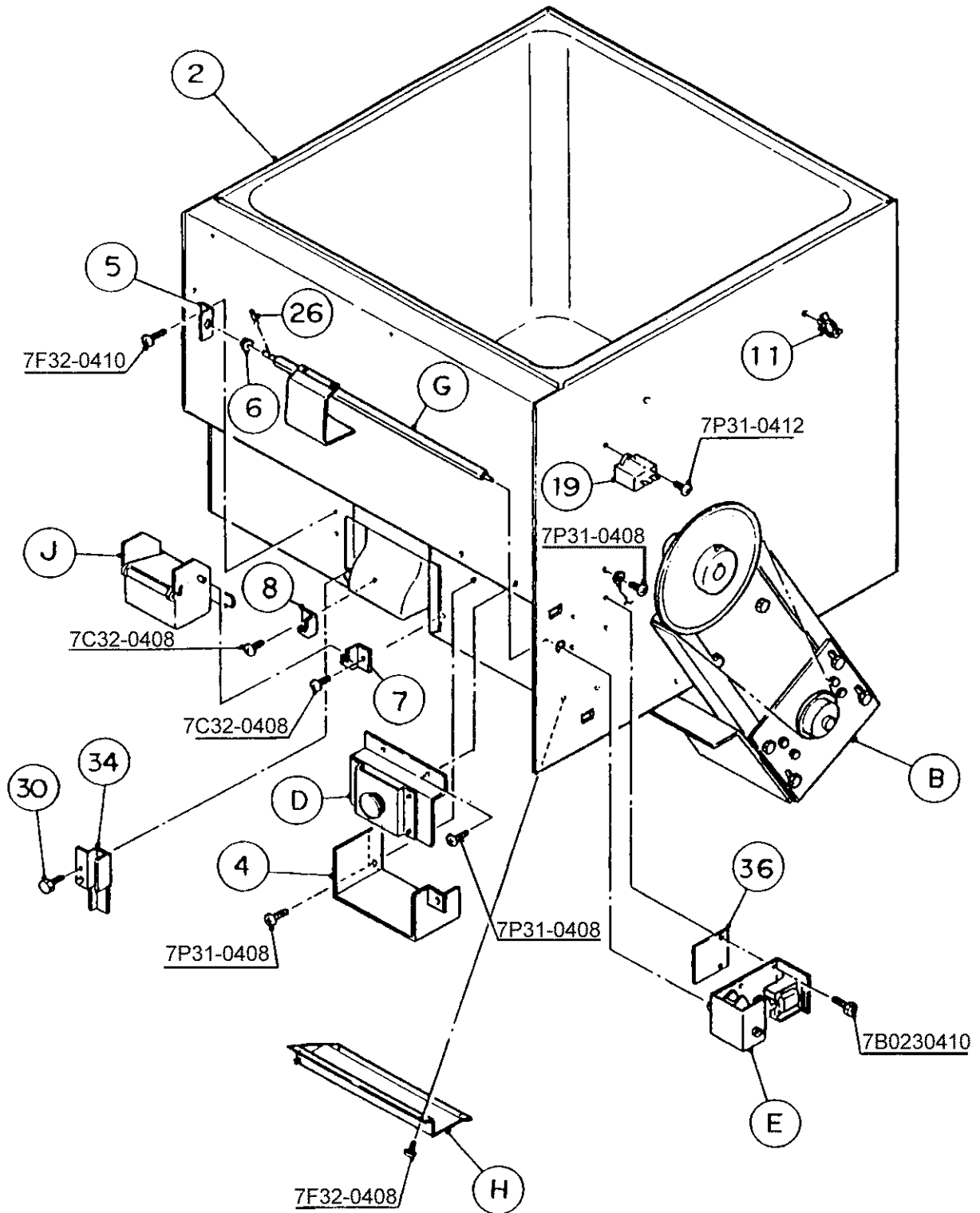

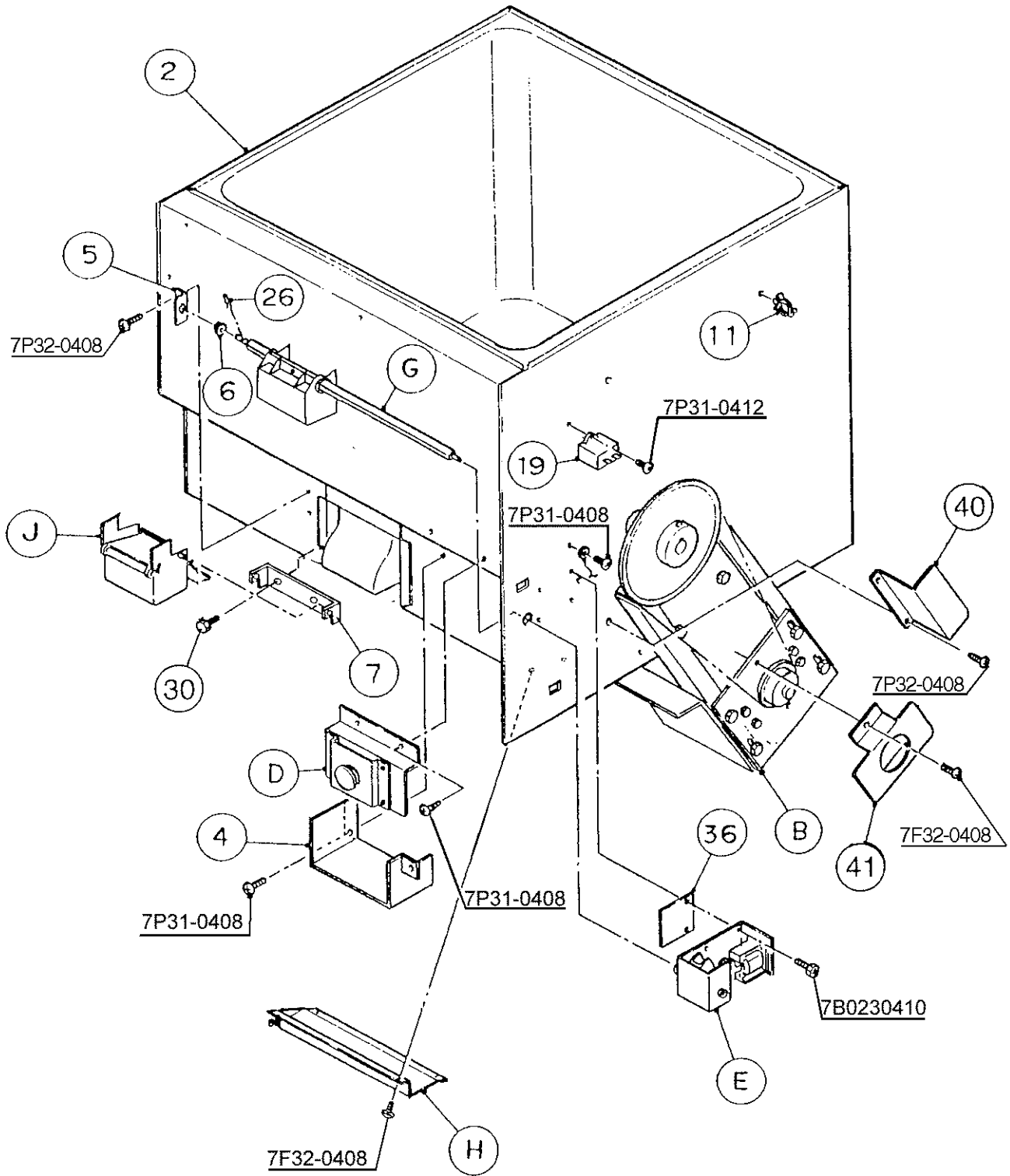

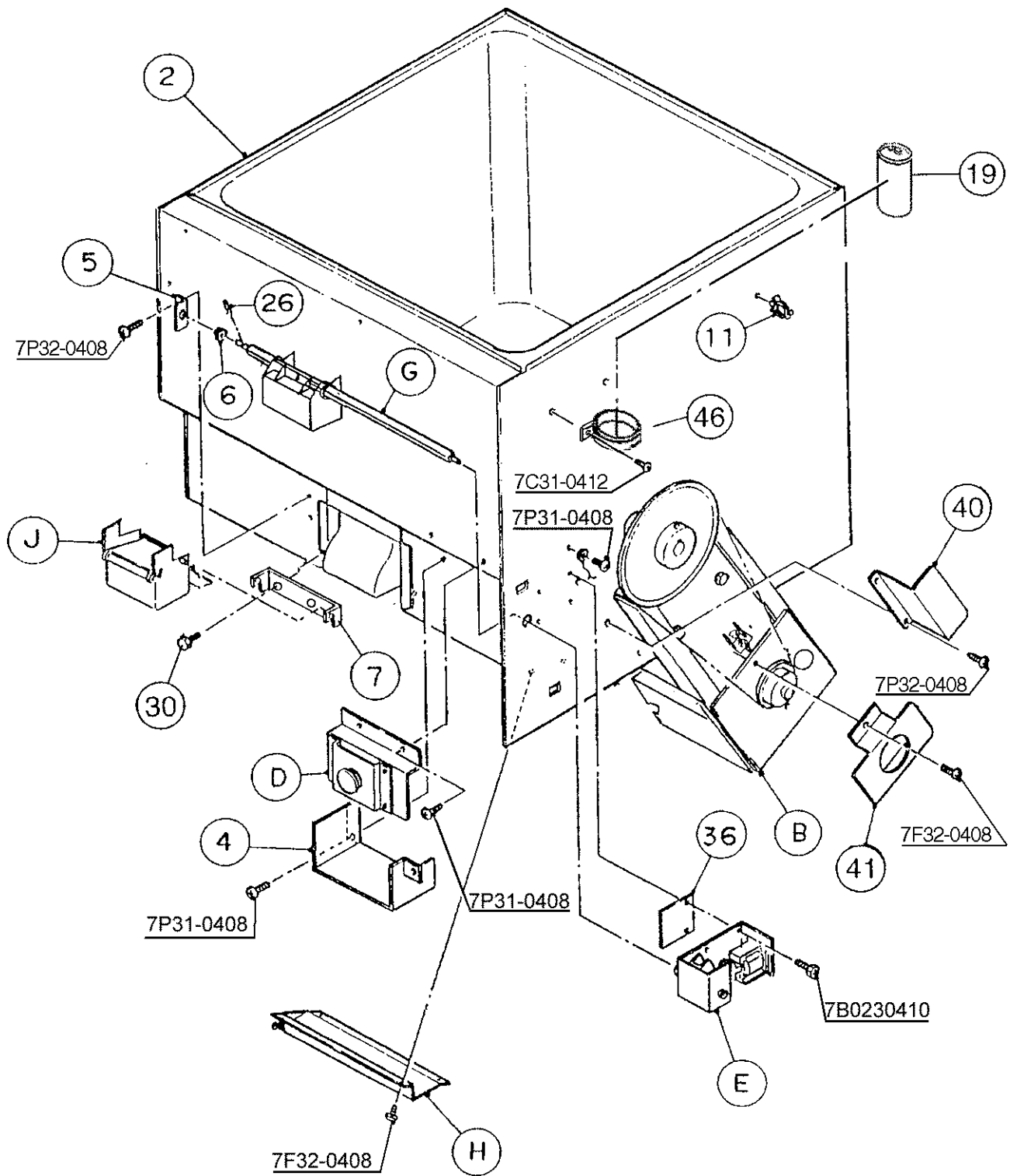

MODEL: DB-200C TITLE: A. DISPENSING BIN ASSEMBLY												
INDEX NO.	DESCRIPTION	MATERIAL OR MODEL NUMBER	PART NUMBER	REQUIRED NUMBER								
				J-1	J-2	K-1	K-2 A-0	A-1 B-0 B-1	B-2 C-0	C-1 D-0	D-1 E-0	
B	MECHANISM ASSEMBLY	-	104513A01	1	1	1	1	1	1	1	-	
		-	1A0109A01								1	
C	CONTROL BOX ASSEMBLY	-	214147A01	1	1	1	1	-				
		-	214147A02					1	1	-		
D	SPOUT SWITCH ASSEMBLY	-	437382A01	1	1	1	1	1	1	1	1	
E	SOLENOID ASSEMBLY	-	212961A01	1	1	1	1	-				
		-	212961A02					1	1	1	1	
F	DRAIN PAN ASSEMBLY	-	212963A01	1	1	1	1	1	-			
		-	212963A02						1	1	1	
G	SHUTTER	-	435537A01	1	1	1	1	-				
		-	328650A01					1	1	1	1	
H	SAFETY SWITCH ASSEMBLY	-	435549A01	1	1	1	1	1	1	1	1	
J	SPOUT	-	323043A01	1	1	-						
		-	324778A01			1	1	-				
		-	326007A01					1	1	1	1	
K	LABEL LOCATION	-	323205A01	1	1	1	1	1	1	1	1	
M	FRAME	-	3A0184A01							1	1	
1	FRAME	GS	104785G01	1	1	1	1	1	1	-		
2	BIN BODY	-	104509G02	1	1	1	1	-				
		-	104509G03					1	-			
		-	106184G01						1	1	1	
3	FRAME (E)	GS	323052-01	1	1	1	1	1	1	1	1	
4	SPOUT SWITCH COVER	GS	3A0043-01	1	1	1	1	1	1	1	1	
5	COLLAR - BRACKET	GS	435546-01	1	1	1	1	-				
		GS	439399-01					1	1	1	1	
6	COLLAR - SHUTTER	POLYOXY-METHYLENE	435533-01	1	1	1	1	1	1	1	1	
7	HOOK	SS	435547-01	1	-							
		SS	4A0063-01		1	1	1	-				
		SS	439398-01					1	1	1	1	
8	HOOK (L)	SS	435548-01	1	-							
		SS	4A0064-01		1	1	1	-				
9	CONTROL BOX (B)	GS	323683-01	1	1	1	1	1	1	1	1	

MODEL: DB-200C TITLE: A. DISPENSING BIN ASSEMBLY											
INDEX NO.	DESCRIPTION	MATERIAL OR MODEL NUMBER	PART NUMBER	REQUIRED NUMBER							
				F-0	F-1	G-0	H-0	J-0	K-0	L-0	
B	MECHANISM ASSEMBLY	-	104513A01								
		-	1A0109A01	1	1	1	1	1	1	1	
C	CONTROL BOX ASSEMBLY	-	214147A01								
		-	214147A02								
D	SPOUT SWITCH ASSEMBLY	-	437382A01	1	1	1	1	1	1	1	
E	SOLENOID ASSEMBLY	-	212961A01								
		-	212961A02	1	x1						
		-	2A0585A01		o1	1	1	1	1	1	
F	DRAIN PAN ASSEMBLY	-	212963A01								
		-	212963A02	1	1	1	1	1	1	1	
G	SHUTTER	-	435537A01								
		-	328650A01	1	1	1	1	1	1	1	
H	SAFETY SWITCH ASSEMBLY	-	435549A01	1	1	1	1	1	1	1	
J	SPOUT	-	323043A01								
		-	324778A01								
		-	326007A01	1	1	1	1	1	1	1	
K	LABEL LOCATION	-	323205A01	1	1	1	1	1	1	1	
M	FRAME	-	3A0184A01	1	1	1	1	1	1	1	
1	FRAME	GS	104785G01								
2	BIN BODY	-	104509G02								
		-	104509G03								
		-	106184G01	1	1	1	1	1	1	1	
3	FRAME (E)	GS	323052-01	1	1	1	1	1	1	1	
4	SPOUT SWITCH COVER	GS	3A0043-01	1	1	1	1	1	1	1	
5	COLLAR - BRACKET	GS	435546-01								
		GS	439399-01	1	1	1	1	1	1	1	
6	COLLAR - SHUTTER	POLYOXY-METHYLENE	435533-01	1	1	1	1	1	1	1	
7	HOOK	SS	435547-01								
		SS	4A0063-01								
		SS	439398-01	1	1	1	1	1	1	1	
8	HOOK (L)	SS	435548-01								
		SS	4A0064-01								
9	CONTROL BOX (B)	GS	323683-01	1	1	1	1	1	1	1	

MODEL: DB-200C TITLE: A DISPENSING BIN ASSEMBLY											
INDEX NO.	DESCRIPTION	MATERIAL OR MODEL NUMBER	PART NUMBER	REQUIRED NUMBER							
				J-1	J-2	K-1	K-2 A-0	A-1 B-0 B-1 B-2 C-0 C-1	D-0	D-1 E-0	F-0 F-1 G-0 H-0 J-0 K-0 L-0
10	CONTROL BOX (C)	GS	323186G01	1	1	1	-				
		GS	323186G02				1	1	1	1	1
11	CLAMP	NO. 4253	427902-05	4	4	4	4	4	4	4	4
12	SCREW - GROUNDING	BRASS	433304-01	1	1	1	-				
		BRASS	433304-02				1	1	1	1	1
13	SQUARE WASHER	COPPER	433537-01	1	1	1	-				
		COPPER	433537-02				1	1	1	1	1
14	BUSHING	SR-30-1	420472-03	1	1	1	1	1	1	1	1
15	JUNCTION BOX COVER	GS	433410-01	1	1	1	1	1	1	1	1
16	REAR PANEL	GS	323051-01	1	1	1	1	1	1	1	1
17	SIDE PANEL	SS	212965G01	2	-						
		SS	214489-01		2	2	-				
		SS	214489-03				2	2	2	2	2
18	-	-	-	-	-	-	-	-	-	-	-
19	CAPACITOR	SH-JPSU	435648-01	1	1	1	1	1	1	-	
		25 MFD 370VAC	439943-02							1	1
20	BRACKET - FRONT PANEL	SS	3A0041-01	1	1	1	1	1	1	1	1
21	TOP PANEL	SS	323046G01	1	1	1	-				
	TOP KIT	PE	325258G01				1	1	-		
		PE	325258G02						1	1	1
22	SEAL (A1)	NBR	435545-02	1	-						
23	SEAL (A2)	NBR	435545-02	1	-						

MODEL: DB-200C TITLE: A DISPENSING BIN ASSEMBLY											
INDEX NO.	DESCRIPTION	MATERIAL OR MODEL NUMBER	PART NUMBER	REQUIRED NUMBER							
				J-1	J-2 K-1	K-2 A-0	A-1 B-0	B-1 B-2	C-0 C-1 D-0 D-1 E-0 F-0	F-1 G-0 H-0 J-0	K-0 L-0
24	FRONT PANEL	ABS	212967G01	1	1	1	1	1	1	1	x1
		ABS	212967G02								o1
25	CABLESTRAP	5782	430361-04	1	1	1	1	1	1	1	
26	SNAP PIN	SS, SSP-6	715S-0006	1	1	1	1	1	1	1	
27	CONTROL BOX (D)	GS	323808-01	1	1	1	1	1	1	1	
28	BUSHING	OCB-750	428394-01	1	1	1	1	1	1	1	
29	DRAIN BOARD	ABS	323054G01	1	1	1	1	1	1	1	-
		ABS	3A1655G01								1
30	THUMBSCREW	ABS, SS	415949G01	3	3	3	3	3	3	3	2
31	PAD	ABS	436580-01	1	1	1	1	1	1	1	1
32	BRACKET DRAIN BOARD	SS	4A0044-01	2	2	2	2	2	2	2	-
33	SUPPORTING PAD	PE FOAM	4A0040-01	1	1	1	1	1	1	1	
34	STOPPER	SS	3A0045-01	1	1	1	-				
35	BRACKET - FRONT PANEL	GS	3A0044-01	1	1	1	1	1	1	1	1
36	SOLENOID ASSEMBLY BASE	GS	4A0048-01	1	1	1	1	1	1	1	1
37	SEAL (REAR)	PVC	4A0055-01		1	1	1	1	1	-	-
	GASKET	L=620	4A0808L01							3	3
38	SEAL (FRONT)	PVC	4A0056-01		1	1	1	1	1	-	-
	GASKET	L=660	4A0808L01							2	2
39	SEAL (SIDE)	PVC	4A0055-01	2	2	2	2	2	2	-	-
40	CHAIN COVER (A)	-	438282-01		1	1	1	1	1	1	1
41	CHAIN COVER (B)	-	438283-01		1	1	1	1	1	1	1
42	TOP KIT (4)	-	214339G01			1	1	1	-		
		-	2A0093-01						1	1	1
43	TOP KIT BRACKET	GS	437729-01			4	4	4	4	4	4

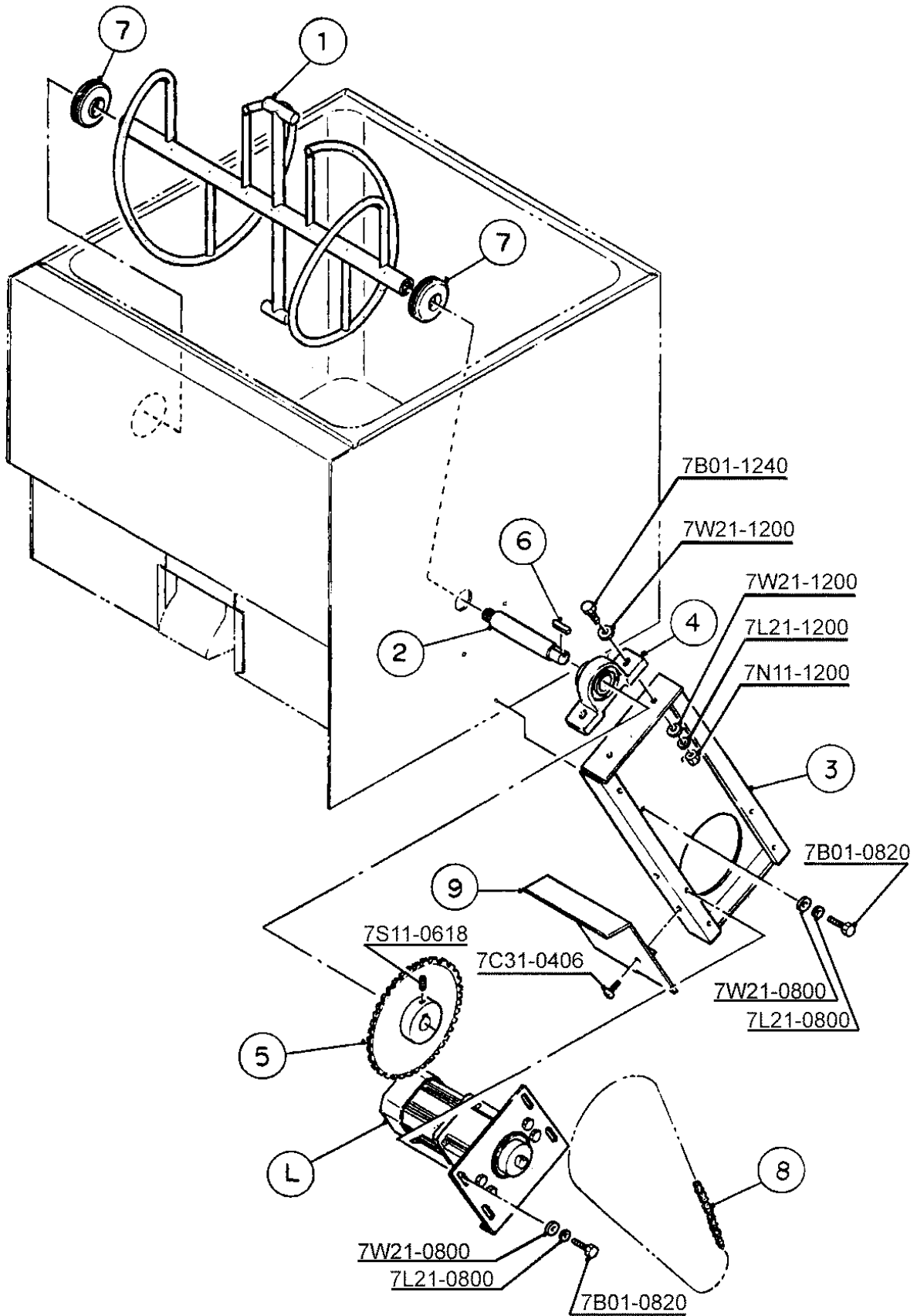

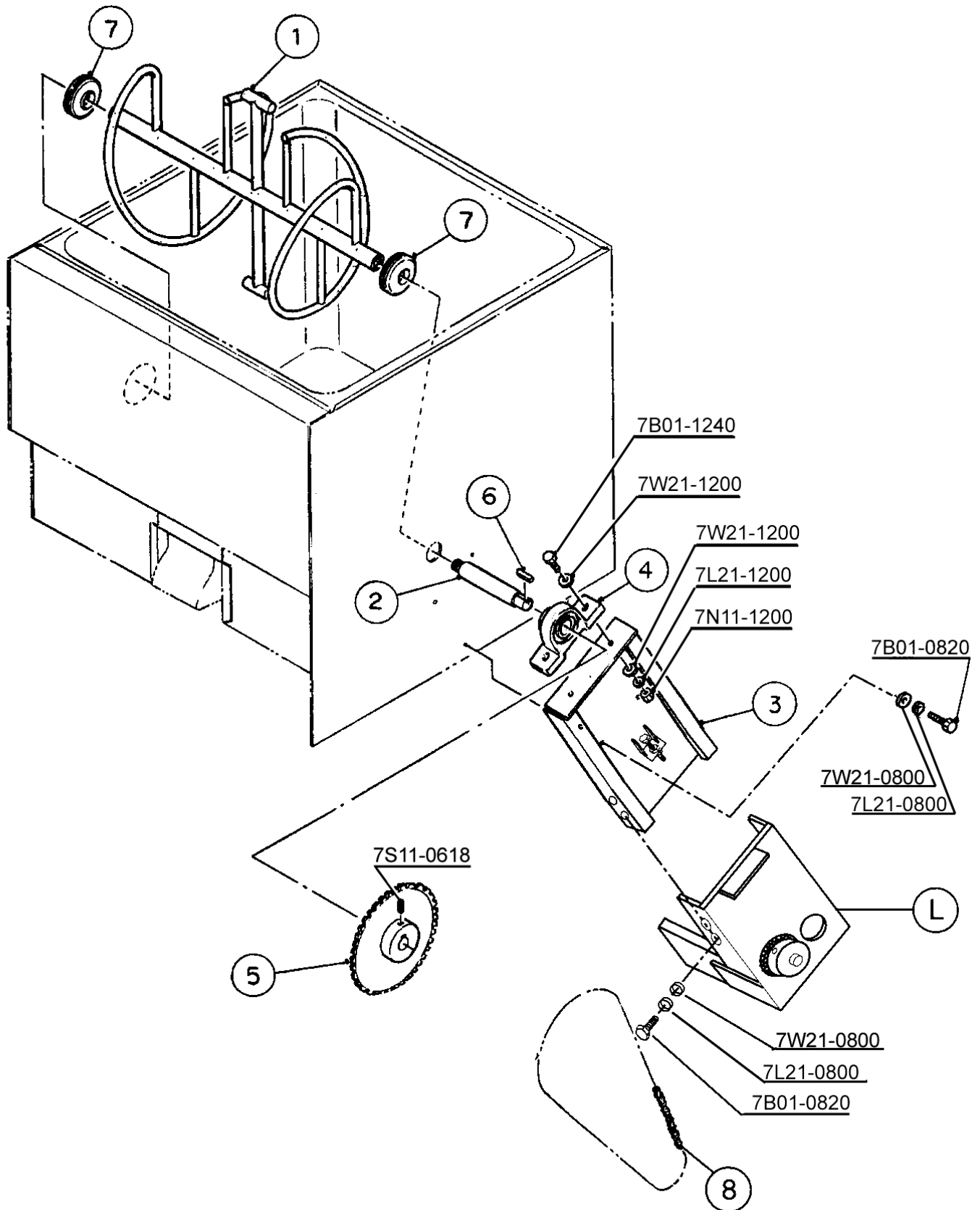

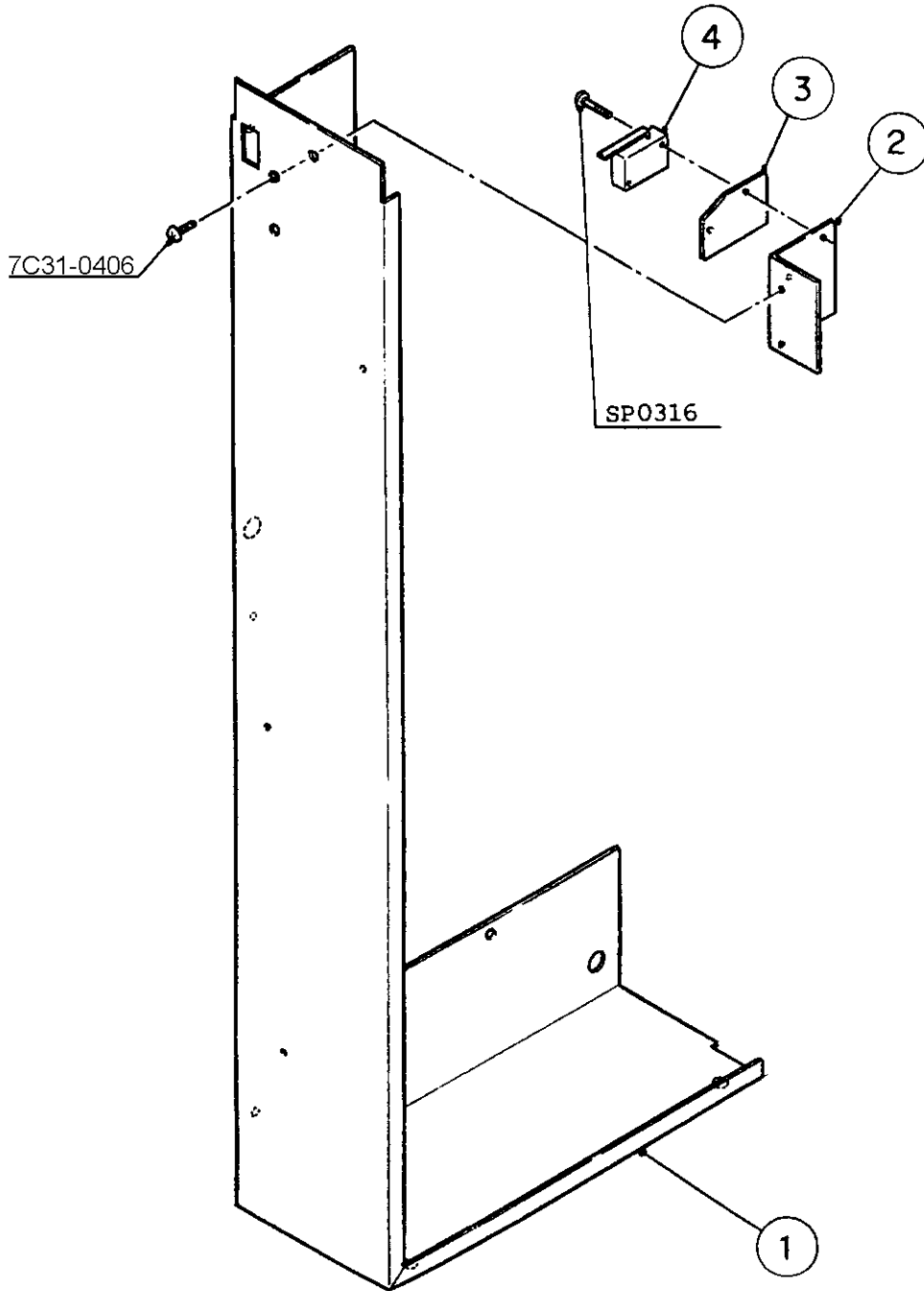

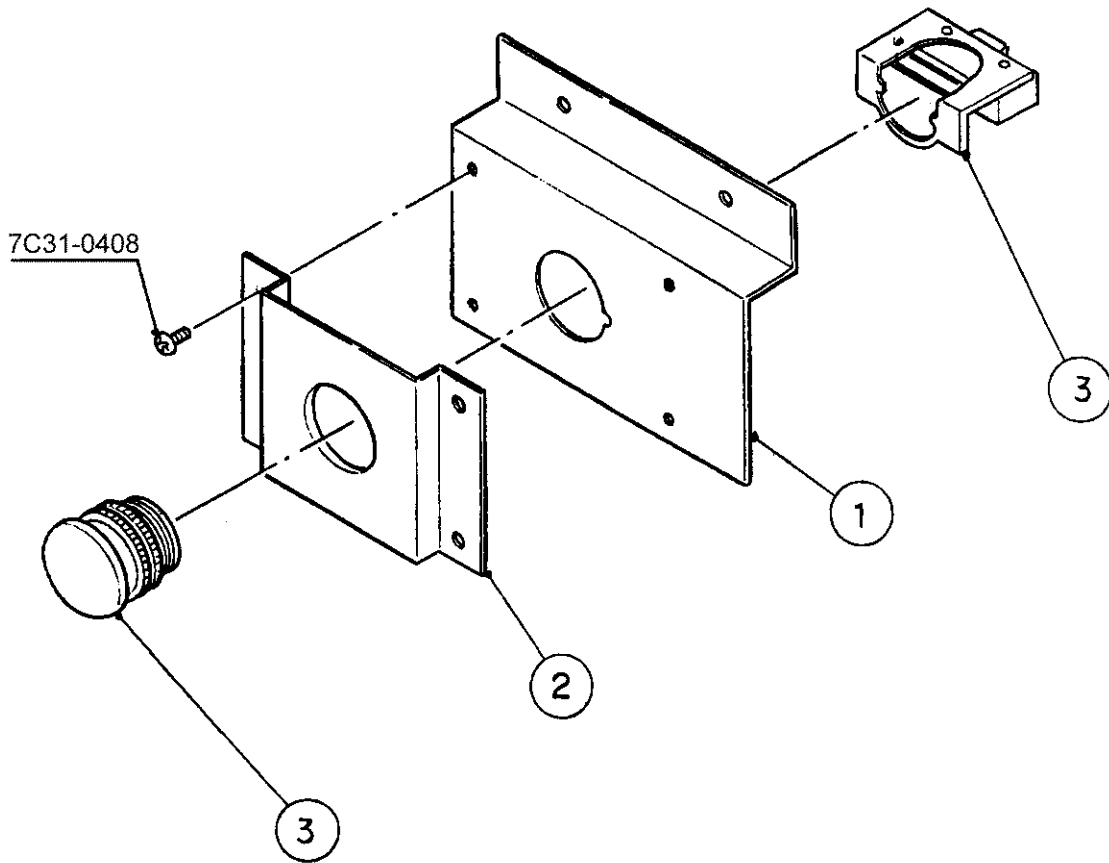

HA
DB-200C

D. SPOUT SWITCH ASSEMBLY

D-1, E-0, F-0, F-1, G-0,
H-0, J-0, K-0, L-0

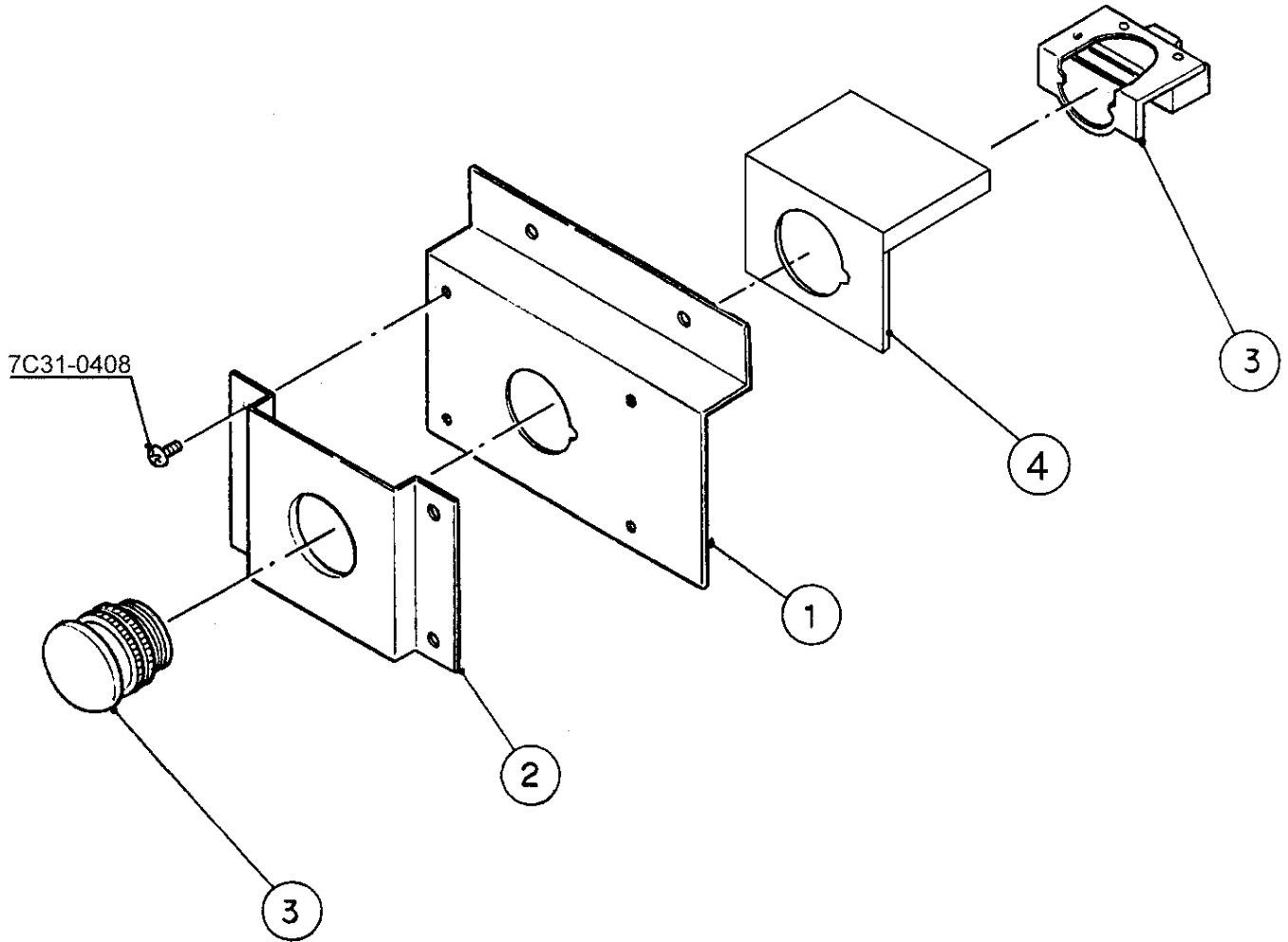

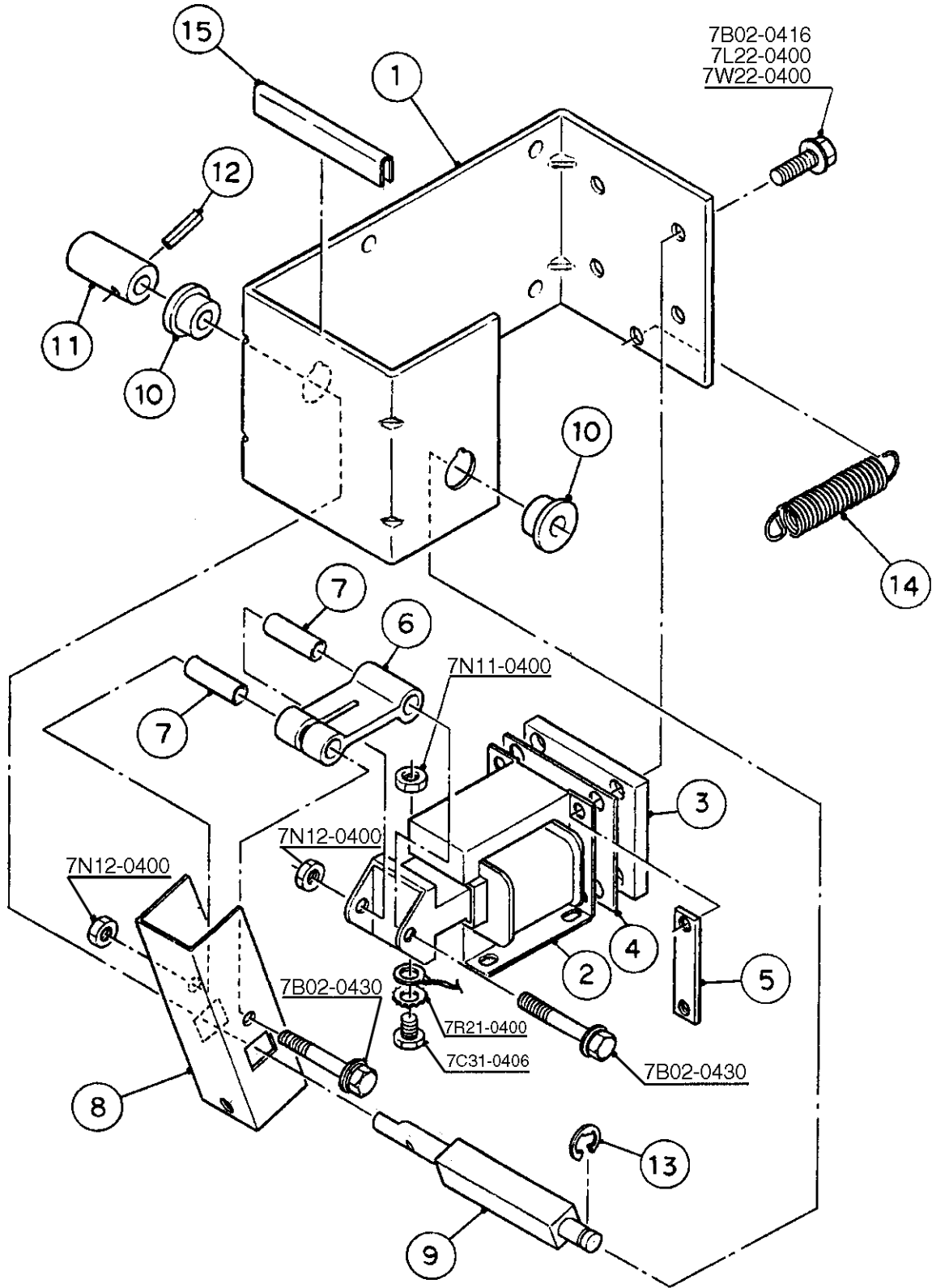

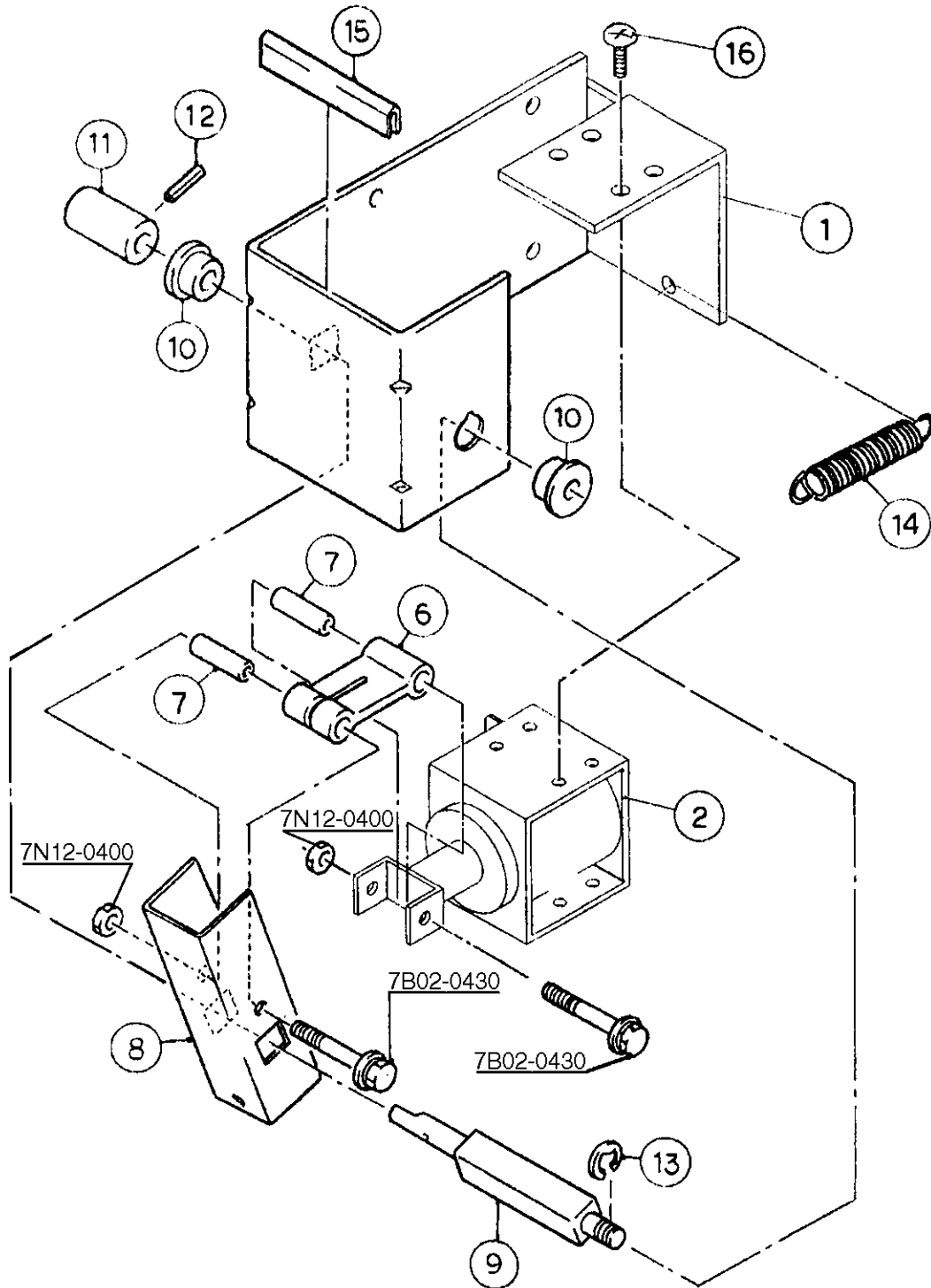

MODEL: DB-200C TITLE: E. SOLENOID ASSEMBLY											
INDEX NO.	DESCRIPTION	MATERIAL OR MODEL NUMBER	PART NUMBER	REQUIRED NUMBER							
				J-1 J-2 K-1 K-2 A-0	A-1 B-0 B-1 B-2 C-0 C-1 D-0 D-1 E-0 F-0	F-1	G-0	H-0	J-0	K-0	L-0
1	SOLENOID BRACKET	GS	323038-01	1	-						
		GS	328649-01		1	x1					
		GS	3A0533-01			o1	1	1	1	1	1
2	SOLENOID	AS-04-A117	3U0095-01	1	1	x1					
		S0071-E	4A0856-01			o1	1	1	1	1	1
3	SOLENOID PACKING	NEOPRENE RUBBER	430380-01	1	1	-					
4	PACKING COVER	SS	431623-02	1	1	-					
5	SOLENOID NUT	SS	429723-02	2	2	-					
6	LINK	POLYOXY-METHYLENE	432232-01	1	1	1	1	1	1	1	1
7	COLLAR (D)	SS	432471-01	2	2	2	2	2	2	2	2
8	LINK - SOLENOID	GS	435531-01	1	1	1	1	1	1	1	1
9	SHAFT	SS	435532-01	1	1	1	1	1	1	1	1
10	COLLAR - SHUTTER	POLYOXY-METHYLENE	435533-01	2	2	2	2	2	2	2	2
11	CONNECTOR	SS	435534-01	1	1	1	1	1	1	1	1
12	SPRING PIN	SS, 3x12	712S-0312	1	1	1	1	1	1	1	1
13	"E" RING	SS, 5	721S-0005	1	1	1	1	1	1	1	1
14	SPRING	SS	432878-01	1	1	1	1	1	1	1	1
15	RUBBER GASKET	SBR	4A0662L01	1	1	1	1	1	1	1	1
16	TRUSS HEAD SCREW	SS	7C32-0416			4	4	4	4	4	4

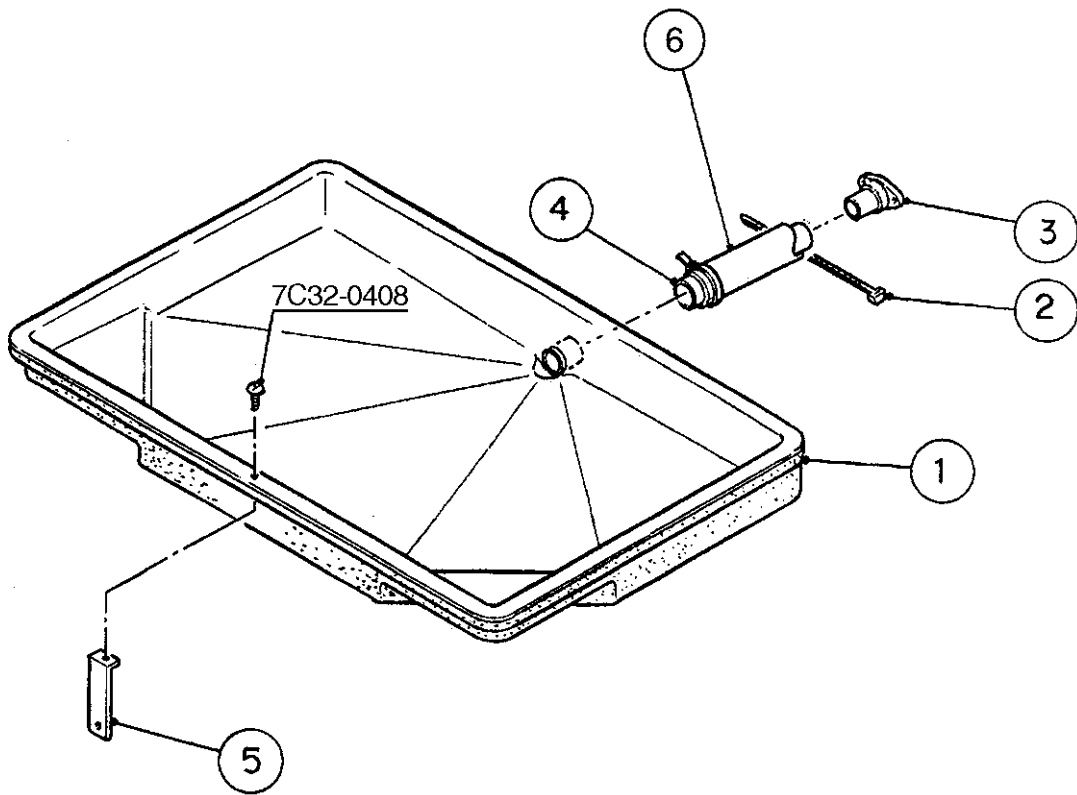

HA
DB-200C

F. DRAIN PAN ASSEMBLY

A-0, A-1, B-0, B-1, B-2, C-0,
C-1, D-0, D-1, E-0, F-0, F-1,
G-0, H-0, J-0, K-0, L-0

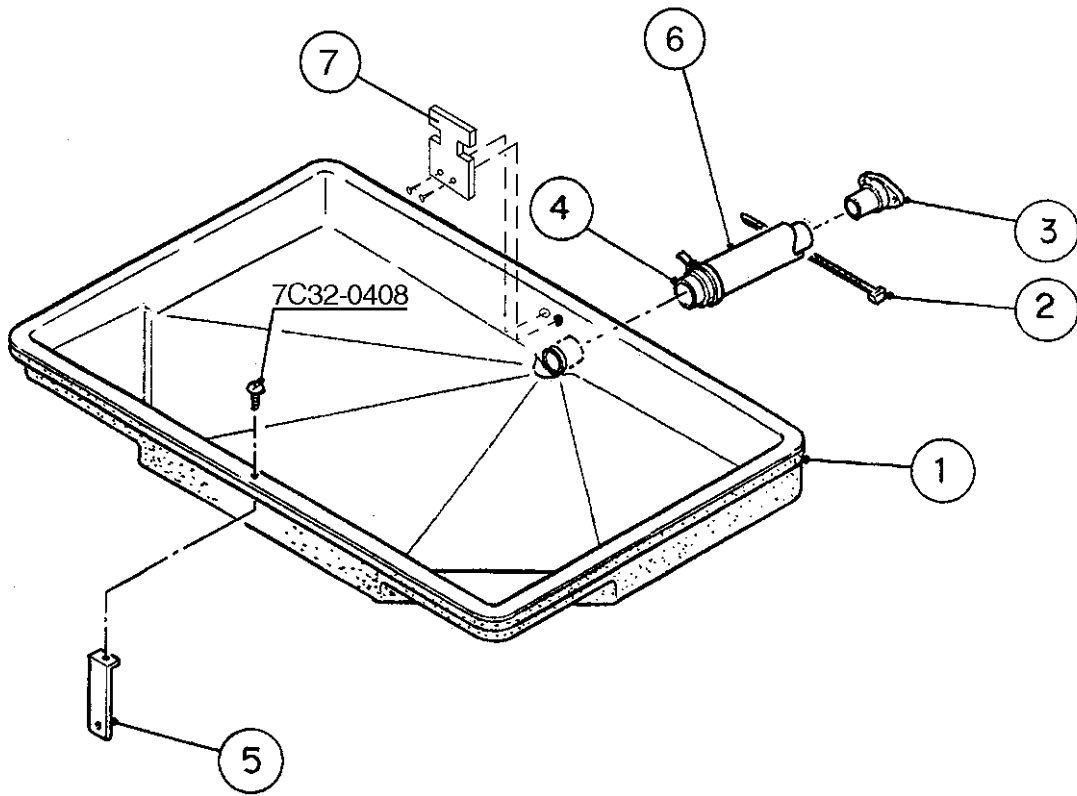

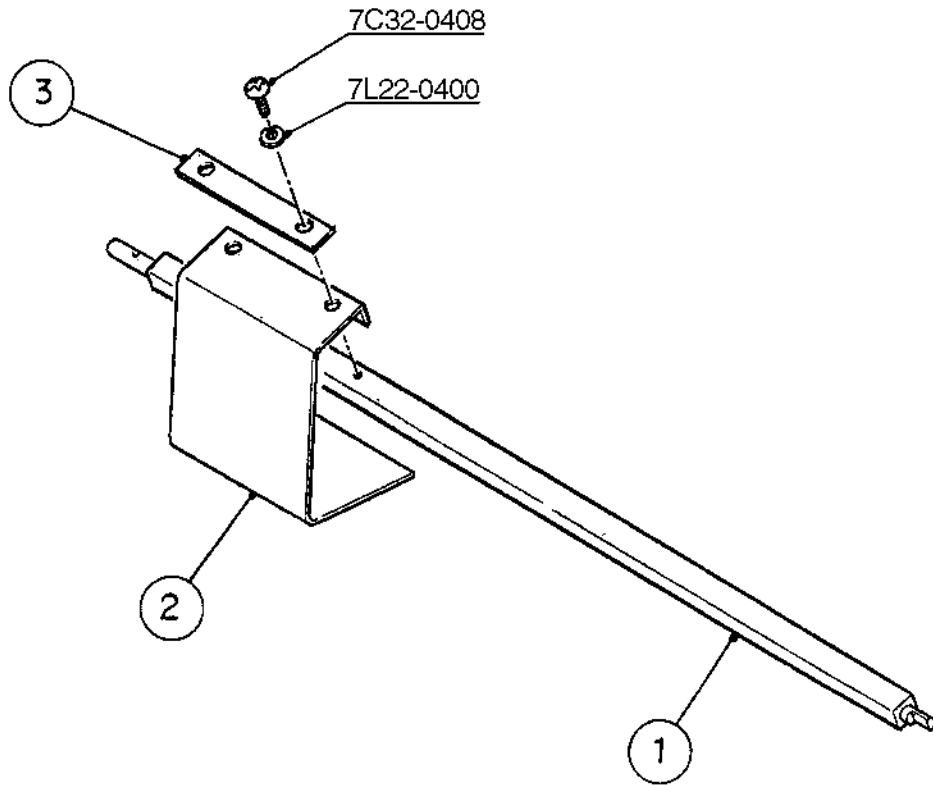

HA
DB-200C

G. SHUTTER

A-1, B-0, B-1, B-2, C-0, C-1, D-0, D-1,
E-0, F-0, F-1, G-0, H-0, J-0, K-0, L-0

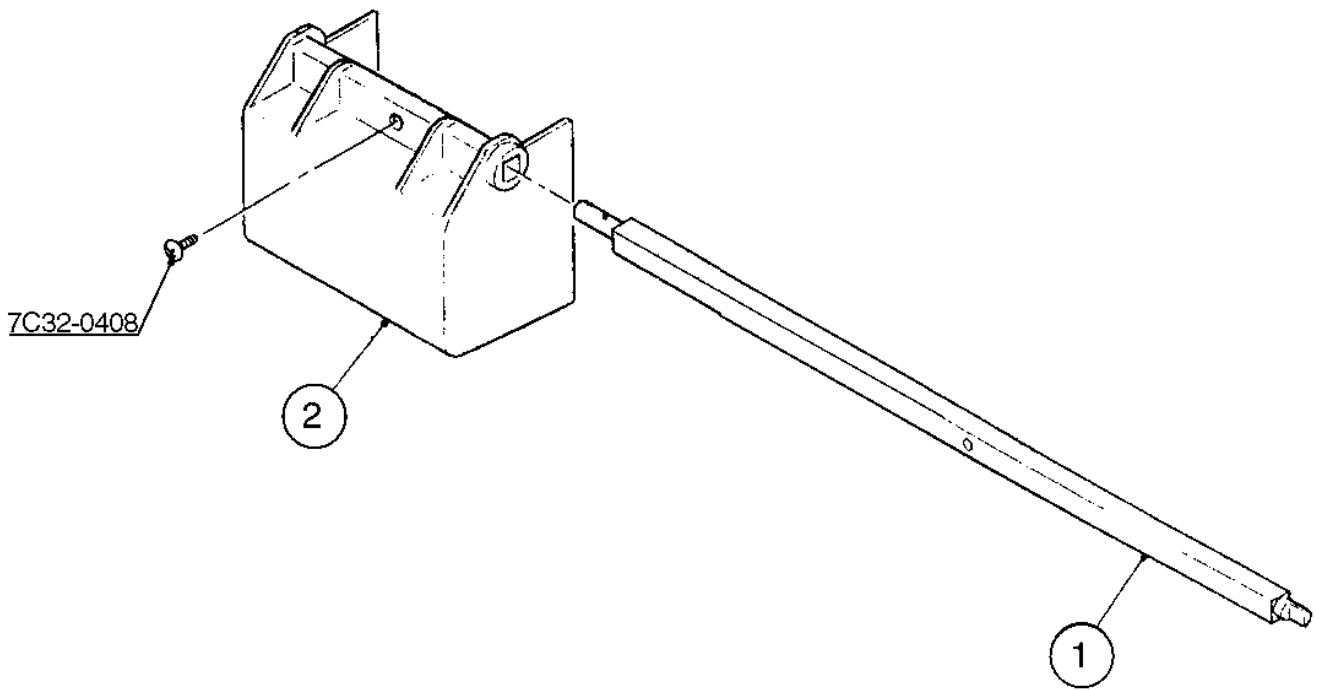

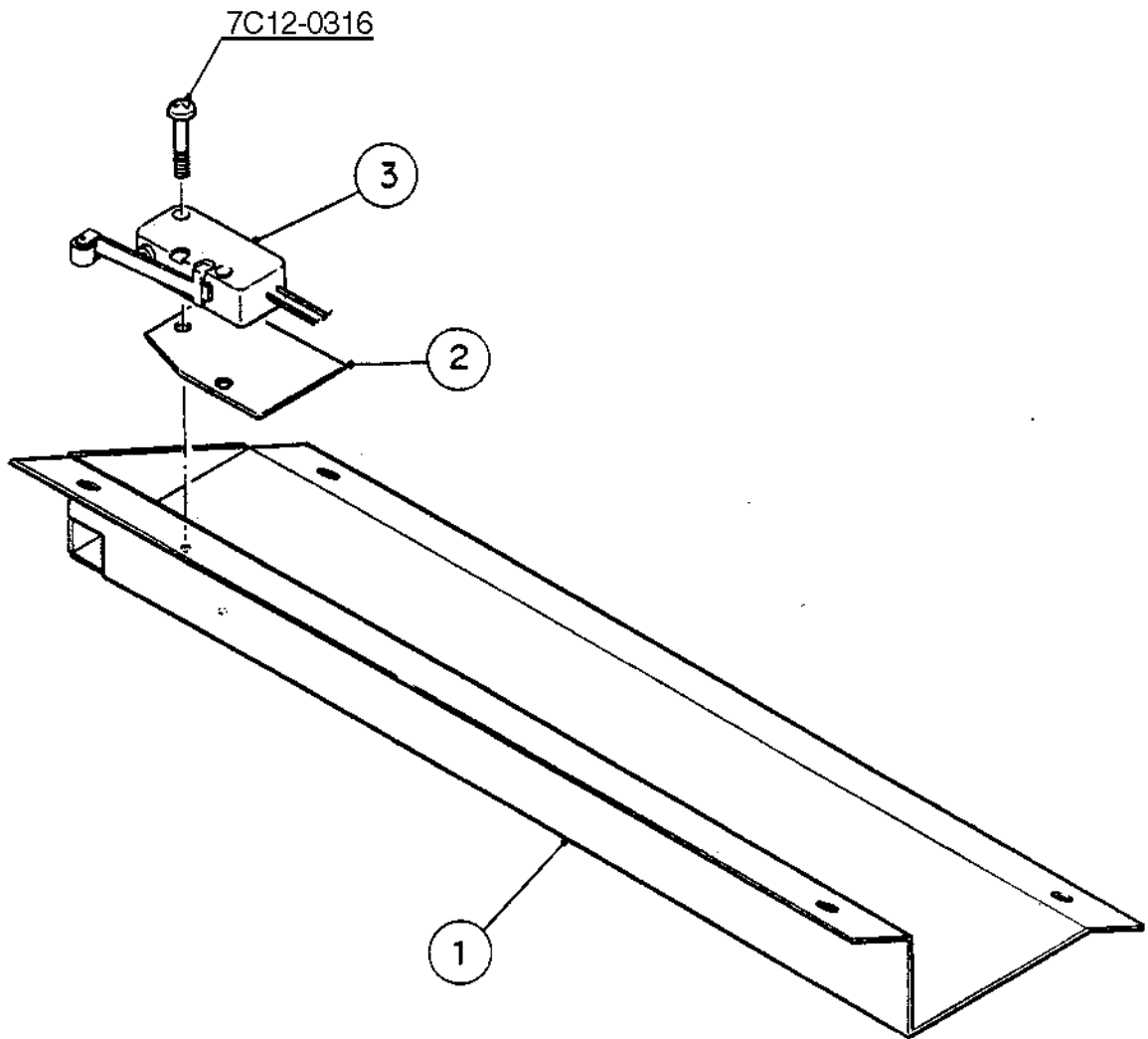

HA
DB-200C

H. SAFETY SWITCH ASSEMBLY

K-1, K-2, A-0, A-1, B-0, B-1, B-2,
C-0, C-1, D-0, D-1, E-0, F-0

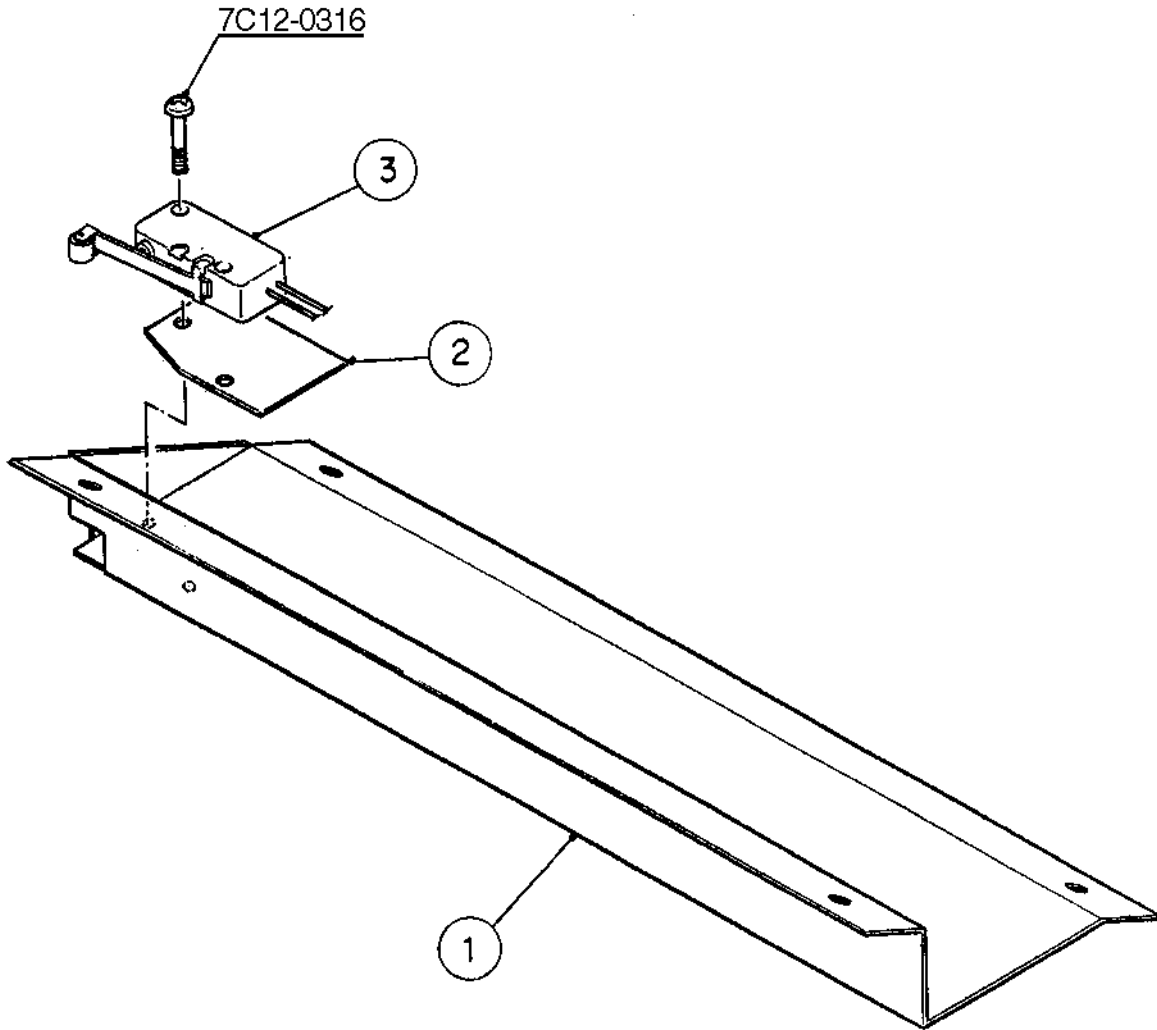

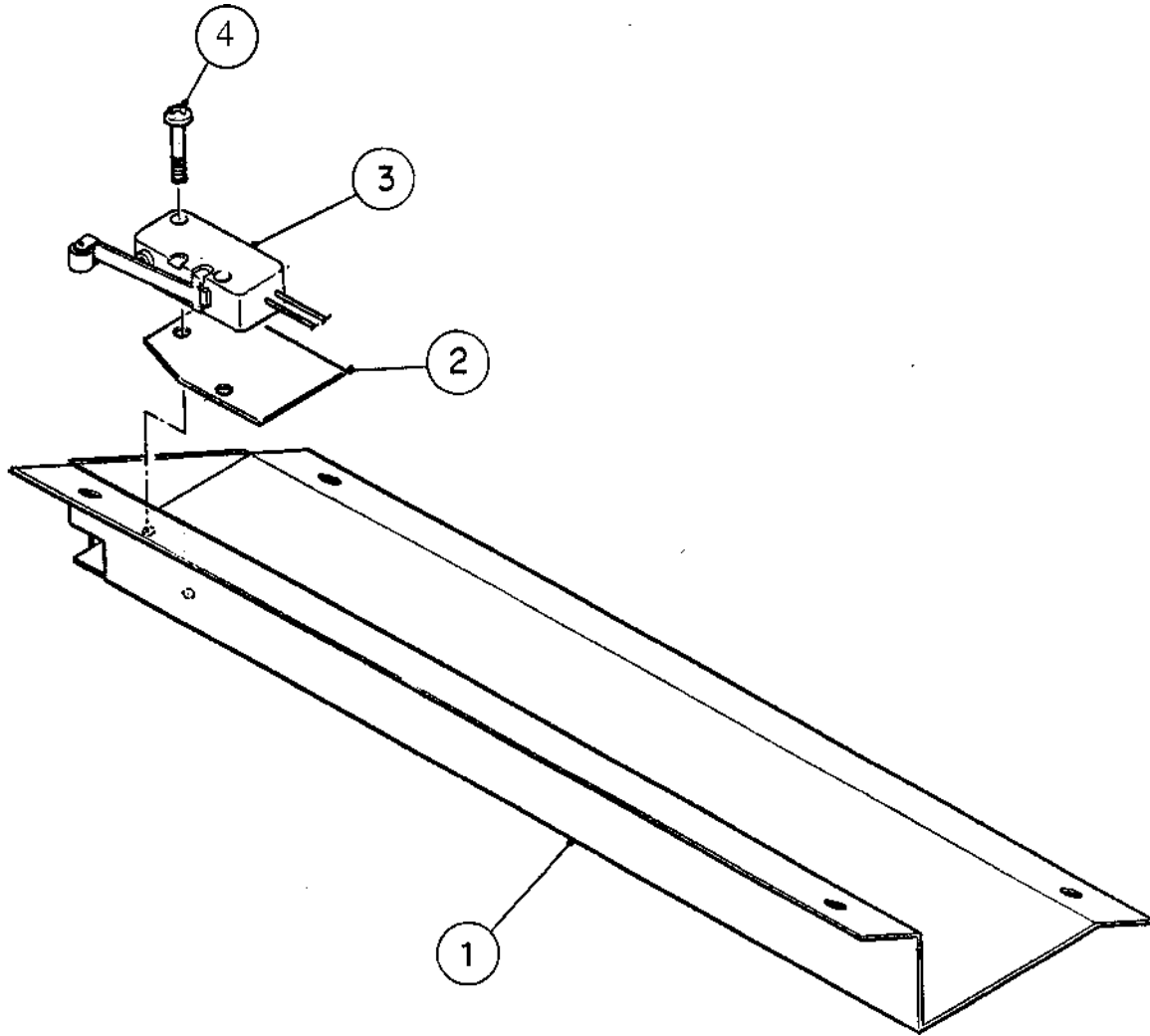

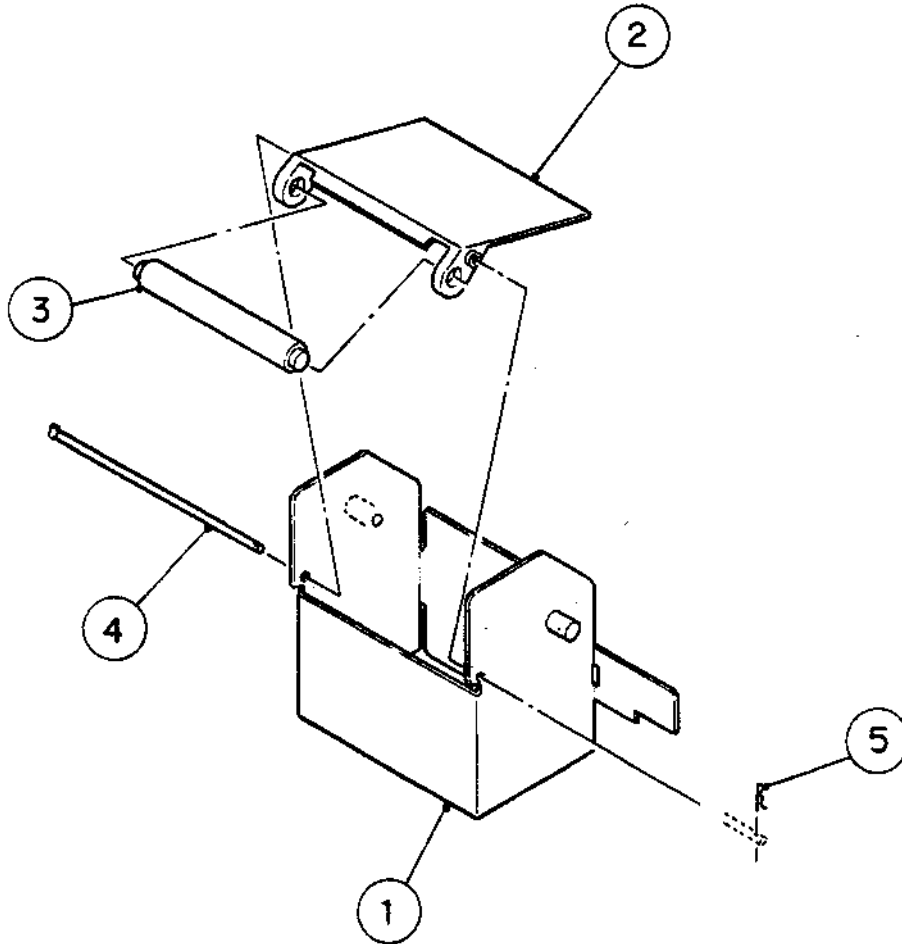

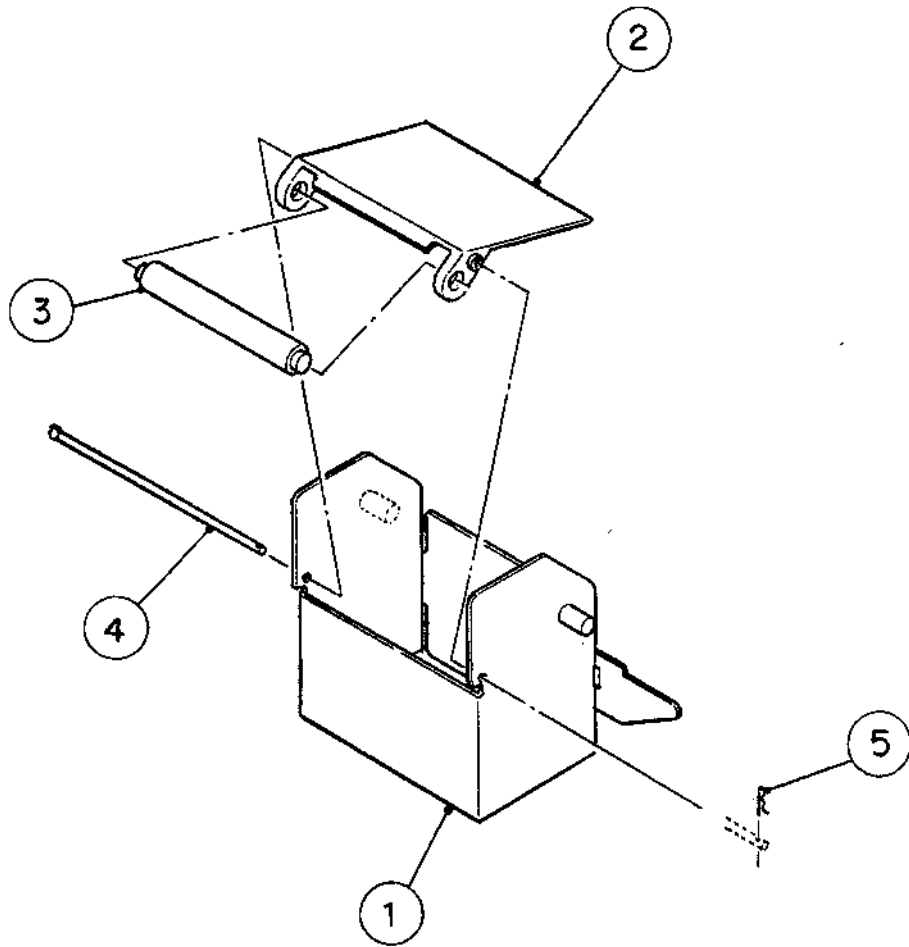

HA
DB-200C

J. SPOUT

A-1, B-0, B-1, B-2, C-0, C-1, D-0, D-1,
E-0, F-0, F-1, G-0, H-0, J-0, K-0, L-0

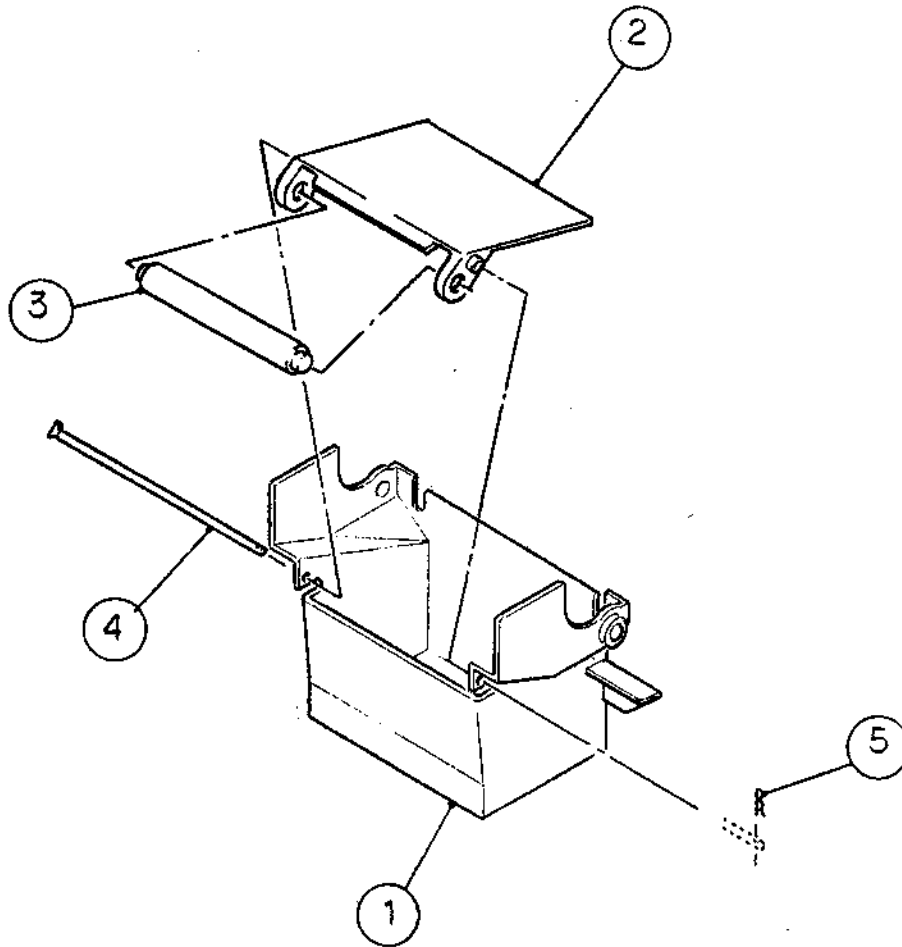

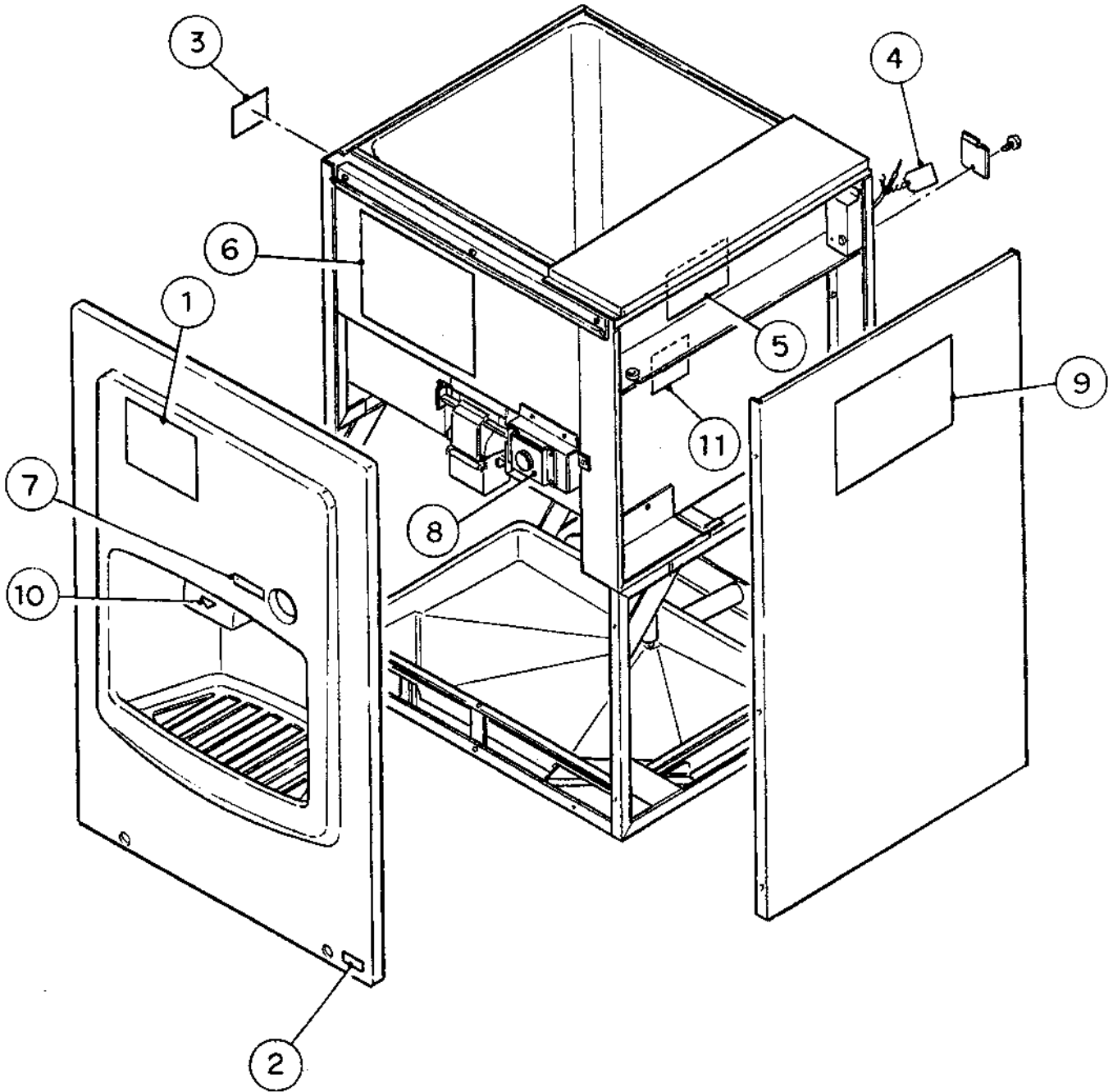

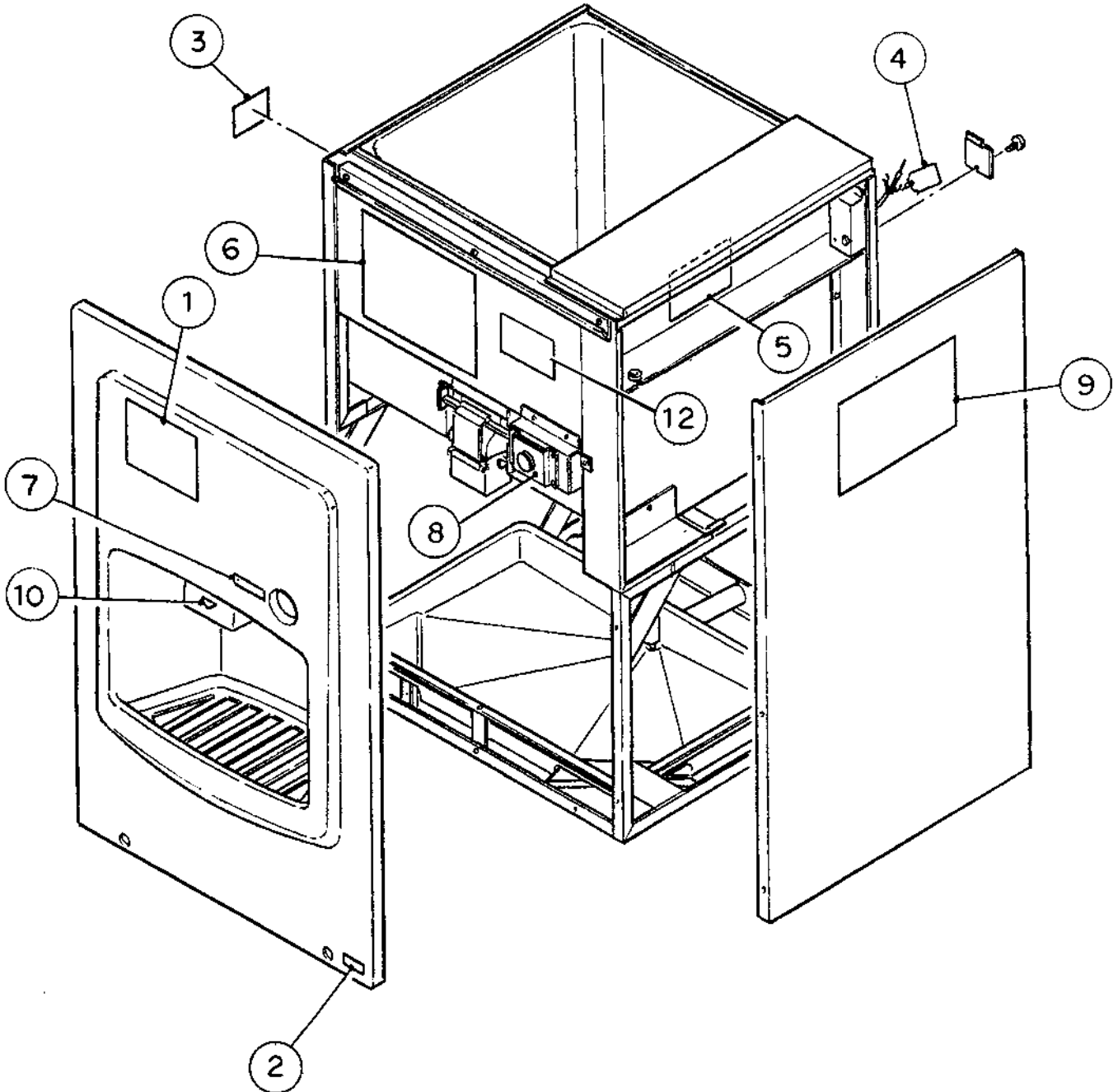

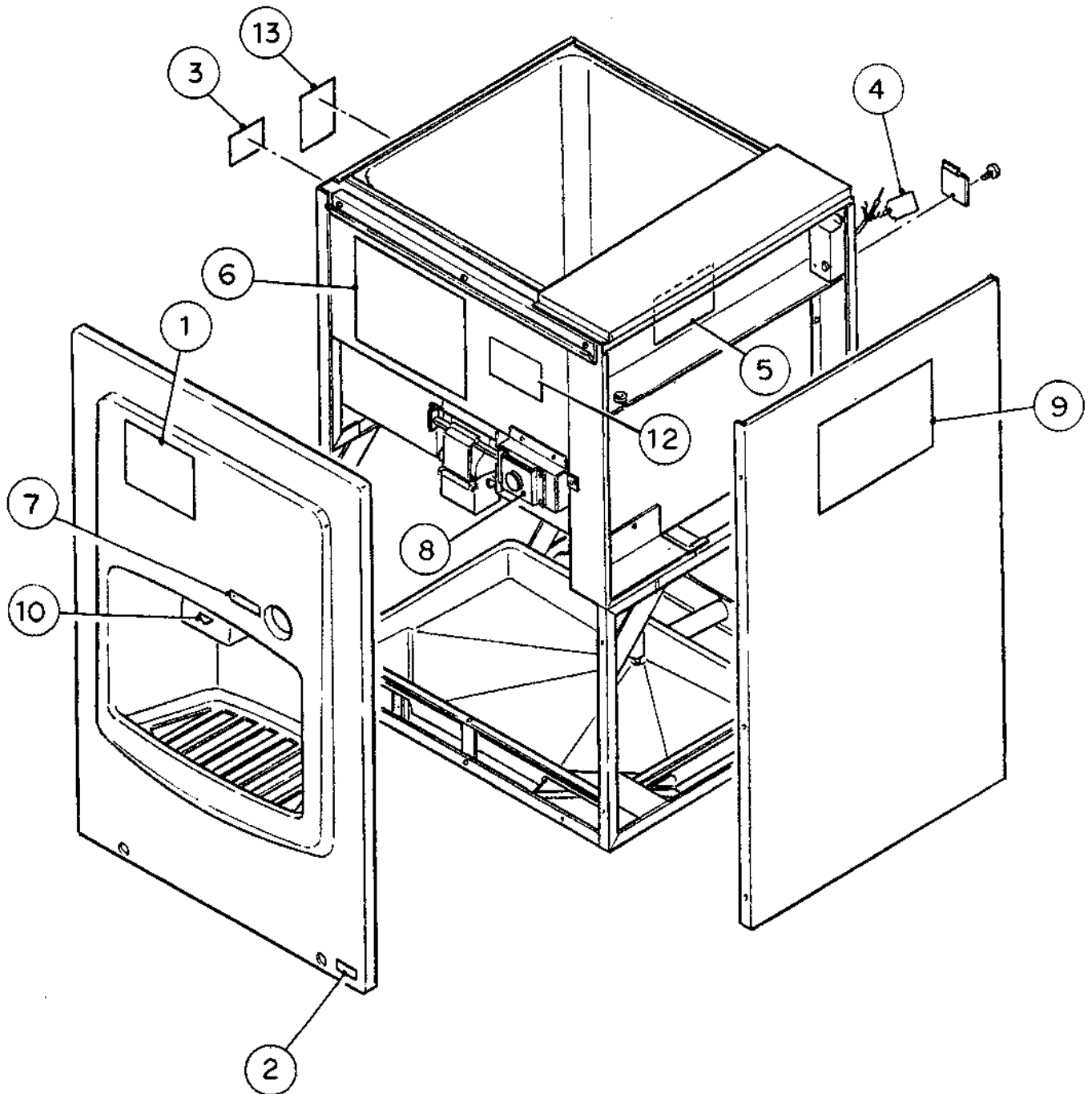

MODEL: DB-200C TITLE: K. LABEL LOCATION											
INDEX NO.	DESCRIPTION	MATERIAL OR MODEL NUMBER	PART NUMBER	REQUIRED NUMBER							
				J-1 J-2 K-1 K-2 A-0 A-1 B-0 B-1 B-2 C-0	C-1 D-0	D-1 E-0 F-0 F-1	G-0	H-0	J-0	K-0	L-0
1	NAMING LABEL	PVC FILM	323207-01	1	1	1	1	1	1	1	1
2	MODEL NUMBER LABEL	PVC FILM	435756-01	1	1	1	1	1	1	1	1
3	NAMEPLATE	PES FILM	4A0502-01	1	1	1	1	1	1	1	1
4	TAG - WARNING: ELECTRICAL CONNECTION	PAPER	435005-01	1	1	1	1	1	1	1	1
5	WIRING LABEL	PVC FILM	323206-01	1	-						
		PVC FILM	329550-01		1	-					
		PVC FILM	3A0405-01			1	1	1	1	1	1
6	MAINTENANCE LABEL	PVC FILM	218264-01	1	1	1	1	1	1	1	1
7	LABEL - SPOUT SWITCH	PVC FILM	435757-01	1	1	1	1	1	1	1	1
8	LABEL - COLOR	PETP FILM	435758-01	1	1	1	1	1	1	1	1
9	INSTRUCTION SHEET	PAPER	218265-01	1	1	1	1	1	1	1	1
10	LABEL - ICE	PVC FILM	436091-01	1	1	1	1	1	1	1	1
11	WARNING LABEL	PVC FILM	436438-01	1	-						
12	CAUTION LABEL (D)	-	439144-01		1	1	1	1	1	1	1
13	LABEL – COMBINATION	-	4A1313-01					1	1	1	1

L. GEAR MOTOR ASSEMBLY

J-1, J-2, K-1, K-2, A-0, A-1,
B-0, B-1, B-2, C-0, C-1, D-0

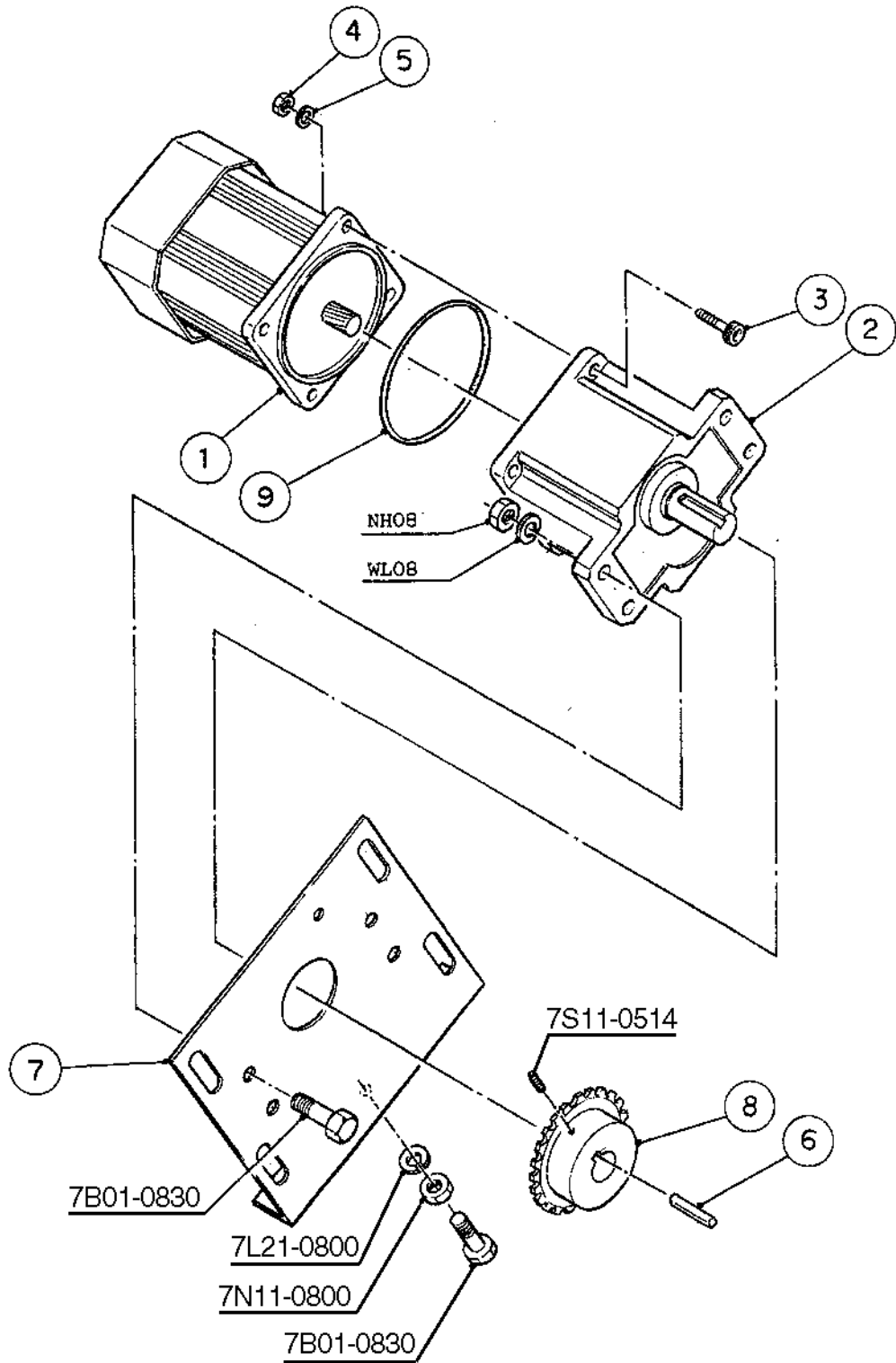

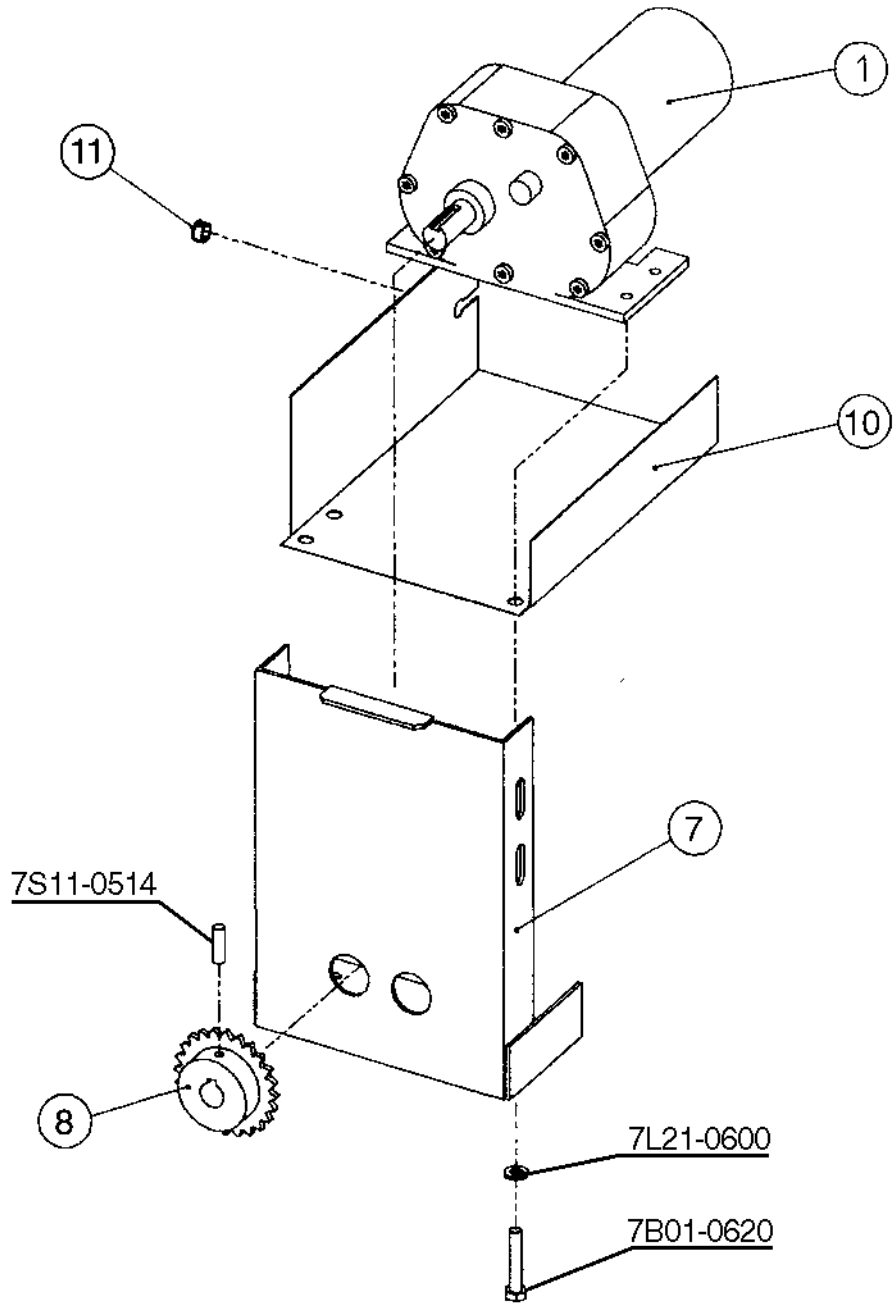

HA
DB-200C

M. FRAME

C-1, D-0, D-1, E-0, F-0, F-1,
G-0, H-0, J-0, K-0, L-0

