NO. 71137

ISSUED: June 9, 1999

REVISED: December 1, 2004



**HOSHIZAKI
CUBELET ICE DISPENSER**

MODEL

**DCM-750BAF
DCM-750BWF**

PARTS LIST

CONTENTS

Auxiliary Codes	3
Material Abbreviations	5
A. Ice Dispenser Assembly	5
DCM-750BAF (1/2)	5
DCM-750BWF (1/2)	6
DCM-750BAF, DCM-750BWF (2/2)	7
B. Frame Assembly	12
DCM-750BAF	12
DCM-750BWF	14
C. Evaporator Assembly	16
DCM-750BAF, DCM-750BWF	16
D. Refrigeration Circuit	18
DCM-750BAF	18
DCM-750BWF	21
E. Water Circuit	25
DCM-750BAF, DCM-750BWF	25
F. Middle Front Panel Assembly	28
DCM-750BAF, DCM-750BWF	28
G. Bin Assembly	30
DCM-750BAF, DCM-750BWF	30
H. Gear Motor Assembly	33
DCM-750BAF, DCM-750BWF	33
I. Gear Motor Assembly (L)	34
DCM-750BAF, DCM-750BWF	34
J. Gear Motor Assembly (R)	35
DCM-750BAF, DCM-750BWF	35
K. Shutter Assembly	36
DCM-750BAF, DCM-750BWF	36
L. Control Box Assembly	39
DCM-750BAF, DCM-750BWF	39
M. Label Location	44
DCM-750BAF, DCM-750BWF	44
N. Bin Top Assembly	47
DCM-750BAF, DCM-750BWF	47
P. Accessories	50
DCM-750BAF, DCM-750BWF	50

Auxiliary Codes

DCM-750BAF	H-0	October 1998
	J-0	December 1998
	J-1	August 1999
	J-2	November 1999
	K-0	December 1999
	K-1	August 2000
	L-0	January 2001
	L-1	November 2001
	M-0	February 2002
	N-0	January 2003

DCM-750BWF	H-0	October 1998
	J-0	December 1998
	K-0	March 2000
	K-1	August 2000
	M-0	February 2002
	M-1	February 2002
	N-0	January 2003

Material Abbreviations

Aluminum

AL = Aluminum

Copper

CU = Copper

Plastic

ABS = Acrylonitrile -butadiene - styrene
AC = Polyacetal
EVA = Ethylene vinyl acetate
PA = Polyamide = Nylon
PC = Polycarbonate
PE = Polyethylene
PES = Polyester
PETP = Polyethylene terephthalate = Tetlon
PP = Polypropylene
PS = Polystyrene
PTFE = Polytetrafluoroethylene = Teflon
PUR = Polyurethane
PVC = Polyvinyl chloride

Rubber

VN = Vinyl Nitrile
EPDM = EP rubber
NBR = Nitrile butadiene rubber
NR = Natural rubber
NP = Neoprene
SI.R = Silicone rubber
SY.R = Synthetic rubber
EPH = Epichlorohydrin

Steel

GS = Galvanized steel
SS = Stainless steel
PS = Plated steel
PAS = Primed steel

Auxiliary Code

K-0

┌─── Designates the year. "K" indicates the year 2000. Years progress or regress in alphabetical order.
│ "J" is 1999, "L" is 2001, "M" is 2002, and so on. The letters "I" and "O" were skipped.
└─── Designates significant part changes within the same year. Base is 0 and this number advances for each change.

Example: P-1

┌─── "P" indicates 2004.
│ └─── "1" indicates the first significant part change for 2004.

Marks Located Under the Auxiliary Code

- = Part deleted.
- x = Part deleted and replaced by "o" part.
- o = New part in place of "x" part.

HA

A. Ice Dispenser Assembly DCM-750BAF (1/2)

H-0, J-0, J-1, J-2, K-0, K-1, L-0, L-1, M-0, N-0

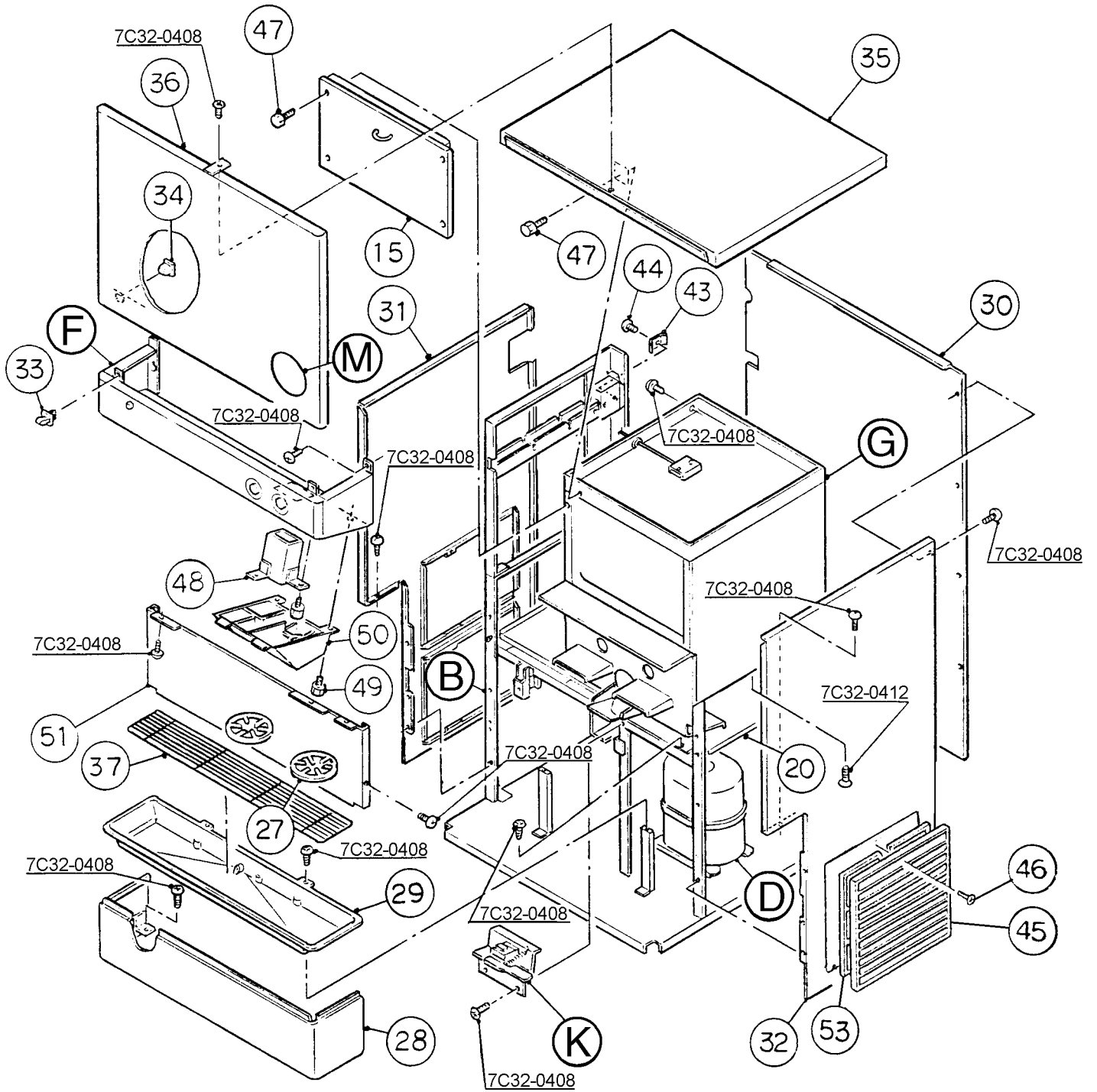

HA

A. Ice Dispenser Assembly DCM-750BWF (1/2)

H-0, J-0, K-0, K-1, M-0, M-1, N-0

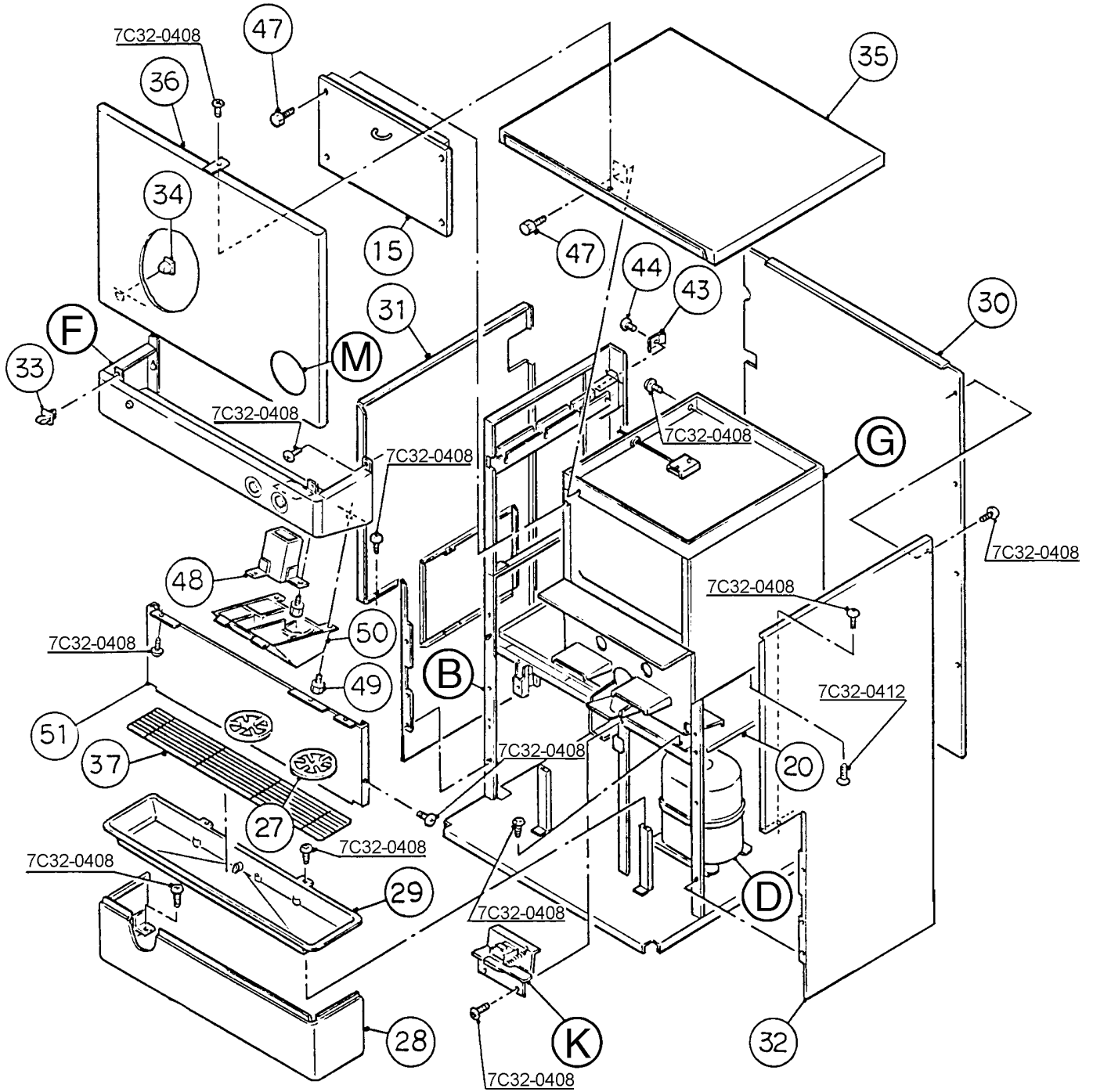

HA

A. Ice Dispenser Assembly DCM-750BAF, DCM-750BWF (2/2)

H-0, J-0, J-1, J-2, K-0, K-1, L-0, L-1, M-0, M-1, N-0

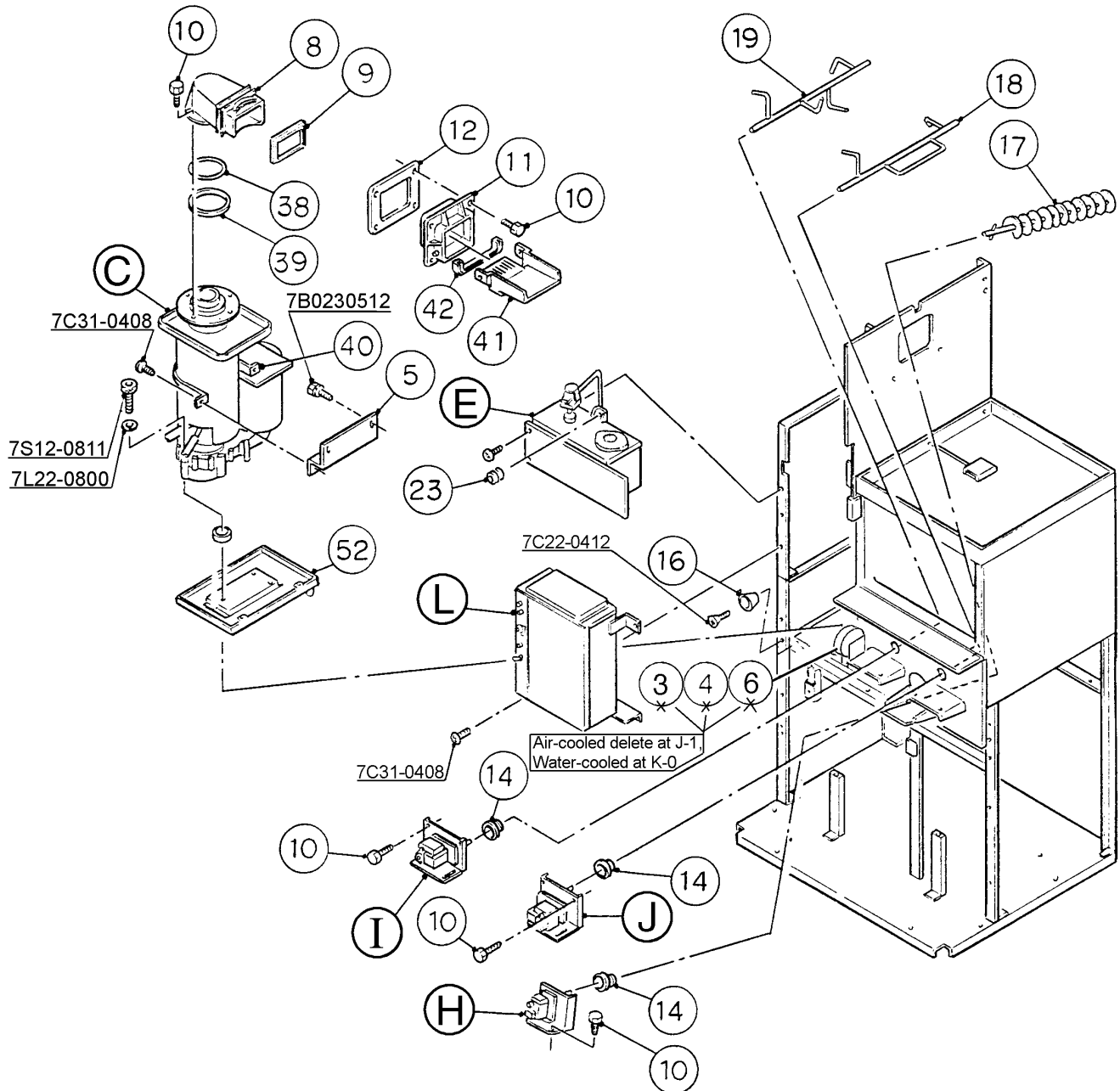

HA

Title: A. Ice Dispenser Assembly Model: DCM-750BAF												
Index No.	Description	Material or Model Number	Part Number	Required Number								
				H-0, J-0	J-1	J-2 K-0	K-1 L-0	L-1 M-0	N-0			
B	FRAME ASSEMBLY	GS	109084A01	1	-							
		GS	109084A02		1	1	1	1	1	1		
C	EVAPORATOR ASSEMBLY	-	324704A02	1	1	1	1	1	1			
	SOCKET HEAD CAP SCREW	SS, 8 X 110	7S12-0811	3	3	3	3	3	3			
	SPLIT LOCK WASHER	SS, 8	7L22-0800	3	3	3	3	3	3			
D	REFRIGERATION CIRCUIT	-	228430A01	1	1	-						
		-	228430A01			1	1	1	1			
E	WATER CIRCUIT	-	2A1274A01	1	1	1	1	1	1			
F	MIDDLE FRONT PANEL ASSEMBLY		228435A02	1	1	1	1	1	1			
	TRUSS HEAD SCREW	SS, 4 X 8	7C32-0408	2	2	2	2	2	2			
G	BIN ASSEMBLY	-	228432A01	1	1	1	1	1	1			
	TRUSS HEAD SCREW	SS, 4 X 8	7C32-0408	3	3	3	3	3	3			
	TRUSS HEAD SCREW	SS, 4 X 12	7C32-0412	2	2	2	2	2	2			
H	GEAR MOTOR ASSEMBLY	-	453209A01	1	1	1	1	1	1			
I	GEAR MOTOR ASSEMBLY (L)	-	454266A01	1	1	1	1	1	1			
J	GEAR MOTOR ASSEMBLY (R)		454396A01	1	1	1	1	1	1			
K	SHUTTER ASSEMBLY	-	2A0410A03	1	1	1	1	1	1			
	TRUSS HEAD SCREW	SS, 4 X 8	7C32-0408	2	2	2	2	2	2			
L	CONTROL BOX ASSEMBLY	-	228434A01	1	x1							
		-	228434A03		o1	-						
		-	228434A05			1	1	1	1			
	TRUSS HEAD SCREW	4 X 8	7C31-0408	4	4	4	4	4	4			
M	LABEL LOCATION	-	228444A03	1	1	-						
		-	228444A05			1	1	-				
		-	228444A03					1	1			
1	-	-	-	-								
2	-	-	-	-								
3	TIMER		4A0889-01	1	-							
4	CONNECTOR		4A0889-02	1	-							
5	BRACKET - EVAPORATOR	SS	431738-01	1	1	1	1	1	1			
	HEX HEAD BOLT W/WASHER (LF)	SS, 5 X 12	7B0230512	2	2	2	2	2	2			
6	SCREW	#6 – 32 X 3/8	4A0898-01	2	-							
7	-		-	-								
8	SPOUT		103932G01	1	1	1	1	1	1			
9	PACKING (A) - SPOUT		427195-01	1	1	1	1	1	1			
10	THUMBSCREW		415949G03	18	18	18	18	18	18			
11	SPOUT (B)		208807-01	1	1	1	1	1	1			
12	PACKING(B) - SPOUT		427196-01	1	1	1	1	1	1			
13	-	-	-	-	-	-	-	-	-			
14	GASKET		429758-01	3	3	3	3	3	3			
15	COVER - BIN		228433A01	1	1	1	1	1	1			
16	COLLAR		4H0171-01	2	2	2	2	2	2			
	FLAT HEAD SCREW	SS, 4 X 12	7C22-0412	2	2	2	2	2	2			
17	AUGER		339194G01	1	1	1	1	1	1			
18	AGITATOR (RIGHT)		321013G01	1	1	1	1	1	1			
19	AGITATOR (LEFT)		319017G02	1	1	1	1	1	1			
20	SEPARATOR		326873-01	1	1	1	1	1	1			

HA

Title: A. Ice Dispenser Assembly Model: DCM-750BAF												
Index No.	Description	Material or Model Number	Part Number	Required Number								
				H-0, J-0	J-1	J-2 K-0	K-1 L-0	L-1 M-0	N-0			
21	-		-	-								
22	-		-	-								
23	BUSHING		420472-03	1	1	1	1	1	1			
24	-		-	-								
25	-		-	-								
26	-		-	-								
27	GUIDE - CUP		326702-01	2	2	2	2	2	2			
28	PANEL (LOWER)		228436G01	1	1	1	1	1	1			
	TRUSS HEAD	SS, 4 X 8	7C32-0408	4	4	4	4	4	4			
29	TRAY - DRIP		105311G01	1	1	1	1	1	x1			
	DRIP TRAY		2A2591G02						o1			
	TRUSS HEAD	SS, 4 X 8	7C32-0408	4	4	4	4	4	4			
30	REAR PANEL		228437-01	1	1	1	1	1	1			
	TRUSS HEAD	SS, 4 X 8	7C32-0408	7	7	7	7	7	7			
31	SIDE PANEL (LEFT)		228438-01	1	1	1	1	1	1			
	TRUSS HEAD	SS, 4 X 8	7C32-0408	6	6	6	6	6	6			
32	SIDE PANEL (RIGHT)		228439-01	1	1	1	1	1	1			
	TRUSS HEAD	SS, 4 X 8	7C32-0408	6	6	6	6	6	6			
33	STRIKE		4A0515-01	2	2	2	2	2	2			
34	LATCH		4A0508-03	2	2	2	2	2	2			
35	TOP PANEL		340938G01	1	1	1	x1					
			3A1729G01				o1	1	1			
36	FRONT PANEL		340971G01	1	1	1	1	1	1			
	TRUSS HEAD SCREW	SS, 4 X 8	7C32-0408	1	1	1	1	1	1			
37	GRILLE		216100G01	1	1	1	1	1	1			
38	"O" RING		7616-G095	1	1	1	1	1	1			
39	RING		431736-01	1	1	1	1	1	1			
40	STRAP		431737-01	1	1	1	1	1	1			
	TRUSS HEAD	SS, 4 X 8	7C32-0408	2	2	2	2	2	2			
41	GUIDE		211171-01	1	1	1	1	1	1			
42	PACKING		320668-01	1	1	1	1	1	1			
43	WASHER		433537-02	1	1	1	1	1	1			
44	SCREW - GROUNDING		433304-02	1	1	1	1	1	1			
45	LOUVER (B)		103121-03	2	2	2	2	2	2			
46	TAPPING SCREW - BLACK		433954-01	2	2	2	2	2	2			
47	THUMBSCREW		415949G05	5	5	5	5	5	5			
48	ICE CHUTE		439788G02	1	1	1	x1					
			4A2204-02				o1	1	1			
49	THUMBSCREW		415949G08	4	4	4	4	4	4			
50	SPOUT COVER		215773-01	1	1	1	1	1	1			
51	APRON PANEL		228443-01	1	1	1	1	1	1			
	TRUSS HEAD	SS, 4 X 8	7C32-0408	5	5	5	5	5	5			
52	DRAIN PAN		323765G02	1	1	1	1	1	1			
53	AIR FILTER (B)		208283G03	1	1	1	1	1	1			

HA

Title: A. Ice Dispenser Assembly Model: DCM-750BWF												
Index No.	Description	Material or Model Number	Part Number	Required Number								
				H-0, J-0	K-0	K-1	M-0	M-1	N-0			
B	FRAME ASSEMBLY	GS	109084A01	1	-							
		GS	109084A02		1	1	1	1	1	1		
C	EVAPORATOR ASSEMBLY	-	324704A02	1	1	1	1	1	1			
	SOCKET HEAD HEX BOLT	SS, 8 X 110	7S12-0811	3	3	3	3	3	3			
	SPLIT LOCK WASHER	SS, 8	7L22-0800	3	3	3	3	3	3			
D	REFRIGERATION CIRCUIT	-	228431A01	1	-							
		-	228431A02		1	1	1	x1				
		-	2A2460A01					o1	1			
E	WATER CIRCUIT	-	2A1274A01	1	1	1	1	1	1			
F	MIDDLE FRONT PANEL ASSEMBLY	-	228435A02	1	1	1	1	1	1			
	TRUSS HEAD SCREW	SS, 4 X 8	7C32-0408	2	2	2	2	2	2			
G	BIN ASSEMBLY	-	228432A01	1	1	1	1	1	1			
	TRUSS HEAD SCREW	SS, 4 X 8	7C32-0408	3	3	3	3	3	3			
	TRUSS HEAD SCREW	SS, 4 X 12	7C32-0412	2	2	2	2	2	2			
H	GEAR MOTOR ASSEMBLY	-	453209A01	1	1	1	1	1	1			
I	GEAR MOTOR ASSEMBLY (L)	-	454266A01	1	1	1	1	1	1			
J	GEAR MOTOR ASSEMBLY (R)		454396A01	1	1	1	1	1	1			
K	SHUTTER ASSEMBLY	-	2A0410A03	1	1	1	1	1	1			
	TRUSS HEAD SCREW	SS, 4 X 8	7C32-0408	2	2	2	2	2	2			
L	CONTROL BOX ASSEMBLY	-	228434A02	1	-							
		-	228434A06		1	1	1	1	1			
	TRUSS HEAD SCREW	4 X 8	7C31-0408	4	4	4	4	4	4			
M	LABEL LOCATION	-	228444A02	1	-							
		-	228444A06		1	1	1	-				
		-	228444A09					1	1			
2	-		-									
3	TIMER		4A0889-02	1	-							
4	CONNECTOR		4A0889-02	1	-							
5	BRACKET - EVAPORATOR	SS	431738-01	1	1	1	1	1				
	HEX HEAD BOLT W/WASHER (LF)	SS, 5 X 12	7B0230512	2	2	2	2	2				
6	SCREW	#6 – 32 X 3/8	4A0898-01	2	-							
7	-		-	-								
8	SPOUT		103932G01	1	1	1	1	1				
9	PACKING (A) - SPOUT		427195-01	1	1	1	1	1				
10	THUMBSCREW		415949G03	18	18	18	18	18				
11	SPOUT (B)		208807-01	1	1	1	1	1				
12	PACKING(B) - SPOUT		427196-01	1	1	1	1	1				
13	-	-	-	-								
14	GASKET		429758-01	3	3	3	3	3				
15	COVER - BIN		228433A01	1	1	1	1	1				
16	COLLAR		4H0171-01	2	2	2	2	2				
	FLAT HEAD SCREW	SS, 4 X 12	7C22-0412	2	2	2	2	2				
17	AUGER		339194G01	1	1	1	1	1				
18	AGITATOR (RIGHT)		321013G01	1	1	1	1	1				
19	AGITATOR (LEFT)		319017G02	1	1	1	1	1				
20	SEPARATOR		326873-01	1	1	1	1	1				

HA

Title: A. Ice Dispenser Assembly Model: DCM-750BWF												
Index No.	Description	Material or Model Number	Part Number	Required Number								
				H-0, J-0	K-0	K-1	M-0	M-1	N-0			
21	-		-	-								
22	-		-	-								
23	BUSHING		420472-03	1	1	1	1	1				
24	-		-	-								
25	-		-	-								
26	-		-	-								
27	GUIDE - CUP		326702-01	2	2	2	2	2				
28	PANEL (LOWER)		228436G01	1	1	1	1	1				
	TRUSS HEAD SCREW	SS, 4 X 8	7C32-0408	4	4	4	4	4				
29	TRAY - DRIP		105311G01	1	1	1	1	1	x1			
	DRIP TRAY		2A2591G02						o1			
	TRUSS HEAD SCREW	SS, 4 X 8	7C32-0408	4	4	4	4	4	4			
30	REAR PANEL		228440-01	1	1	1	1	1	1			
	TRUSS HEAD SCREW	SS, 4 X 8	7C32-0408	7	7	7	7	7	7			
31	SIDE PANEL (LEFT)		228441-01	1	1	1	1	1	1			
	TRUSS HEAD SCREW	SS, 4 X 8	7C32-0408	6	6	6	6	6	6			
32	SIDE PANEL (RIGHT)		228442-01	1	1	1	1	1	1			
	TRUSS HEAD SCREW	SS, 4 X 8	7C32-0408	6	6	6	6	6	6			
33	STRIKE		4A0515-01	2	2	2	2	2	2			
34	LATCH		4A0508-03	2	2	2	2	2	2			
35	TOP PANEL		340938G01	1	1	1	1	1	1			
36	FRONT PANEL		340971G01	1	1	1	1	1	1			
	TRUSS HEAD SCREW	SS, 4 X 8	7C32-0408	1	1	1	1	1	1			
37	GRILLE		216100G01	1	1	1	1	1	1			
38	"O" RING		7616-G095	1	1	1	1	1	1			
39	RING		431736-01	1	1	1	1	1	1			
40	STRAP		431737-01	1	1	1	1	1	1			
	TRUSS HEAD SCREW	SS, 4 X 8	7C32-0408	2	2	2	2	2	2			
41	GUIDE		211171-01	1	1	1	1	1	1			
42	PACKING		320668-01	1	1	1	1	1	1			
43	WASHER		433537-02	1	1	1	1	1	1			
44	SCREW - GROUNDING		433304-02	1	1	1	1	1	1			
45	-		-	-								
46	-		-	-								
47	THUMBSCREW		415949G05	5	5	5	5	5	5			
48	ICE CHUTE		439788G02	1	1	x1						
			4A2204-02			o1	1	1	1			
49	THUMBSCREW		415949G08	4	4	4	4	4	4			
50	SPOUT COVER		215773-01	1	1	1	1	1	1			
51	APRON PANEL		228443-01	1	1	1	1	1	1			
	TRUSS HEAD SCREW	SS, 4 X 8	7C32-0408	5	5	5	5	5	5			
52	DRAIN PAN		323765G02	1	1	1	1	1	1			

HA

B. Frame Assembly
DCM-750BAF

H-0, J-0, J-1, J-2, K-0, K-1, L-0, L-1, M-0, N-0

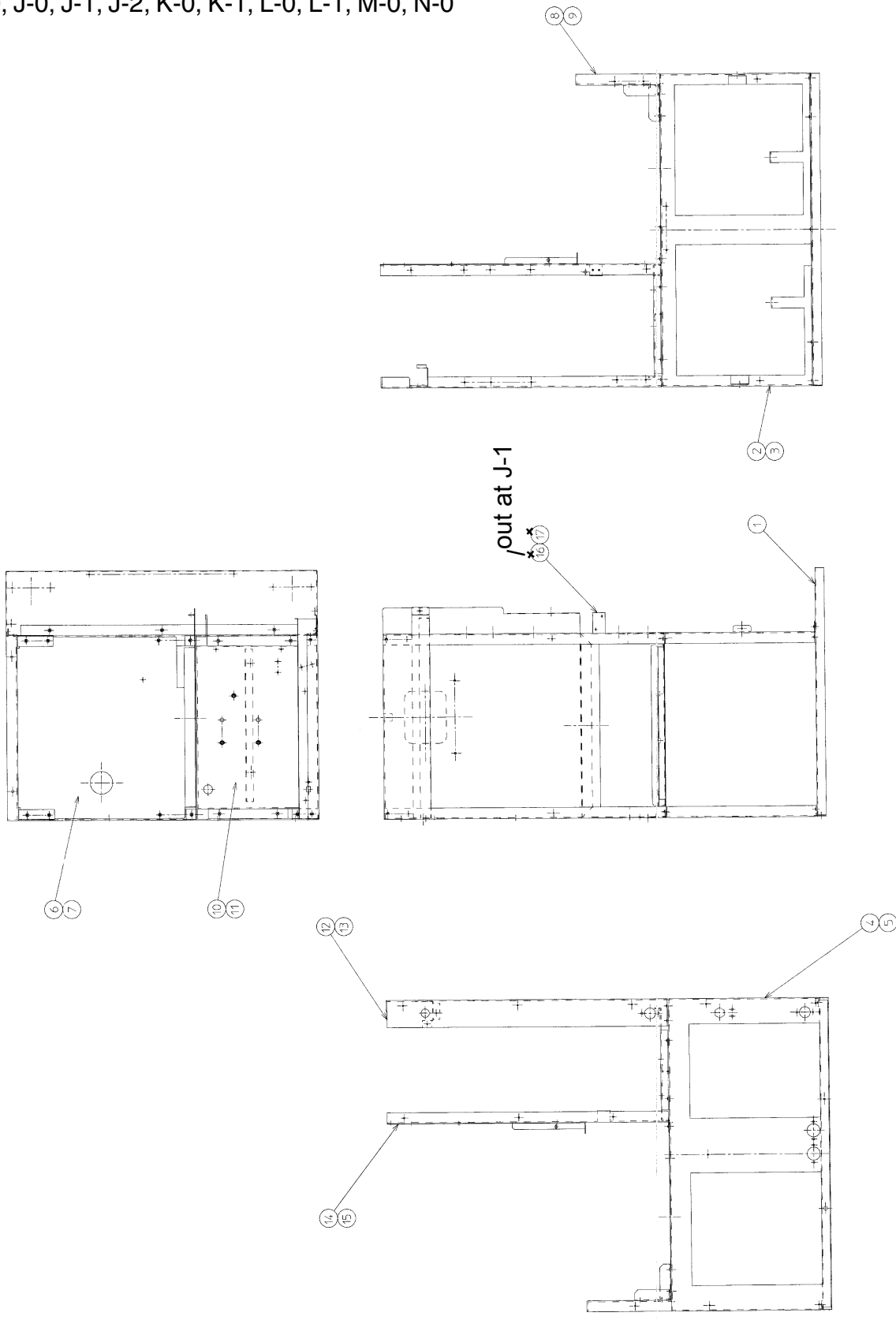

HA

Title: B. Frame Assembly Model: DCM-750BAF												
Index No.	Description	Material or Model Number	Part Number	Required Number								
				H-0, J-0	J-1 J-2	K-0	K-1	L-0 L-1	M-0	N-0		
1	BASE	-	3A1420G01	1	1	1	1	1	1	1		
2	FRONT FRAME	-	228446G01	1	1	1	1	1	1	1		
3	TRUSS HEAD SCREW	4X8	7P31-0408	5	5	5	5	5	5	5		
4	REAR FRAME	-	228447-01	1	1	1	1	1	1	1		
5	TRUSS HEAD SCREW	4X8	7C31-0408	3	3	3	3	3	3	3		
6	SEPARATOR	-	340973-01	1	1	1	1	1	1	1		
7	TRUSS HEAD SCREW	4X8	7C31-0408	2	2	2	2	2	2	2		
8	SIDE FRAME (R)	-	340974G01	1	1	1	1	1	1	1		
9	TRUSS HEAD	4X8	7C31-0408	4	4	4	4	4	4	4		
10	BRACKET – GEAR MOTOR	-	340975G01	1	1	1	1	1	1	1		
11	TRUSS HEAD SCREW	4X8	7C31-0408	4	4	4	4	4	4	4		
12	SIDE FRAME (UPPER)	-	340976G01	1	1	1	1	1	1	1		
13	TRUSS HEAD SCREW	4X8	7C31-0408	3	3	3	3	3	3	3		
14	CENTER PANEL	-	340977G01	1	1	1	1	1	1	1		
15	TRUSS HEAD SCREW	4X8	7C31-0408	2	2	2	2	2	2	2		
16	BRACKET	-	4A1548-01	1	-							
17	TRUSS HEAD SCREW	4X8	7C31-0408	2	-							

HA

B. Frame Assembly
DCM-750BWF

H-0, J-0, K-0, K-1, M-0, M-1, N-0

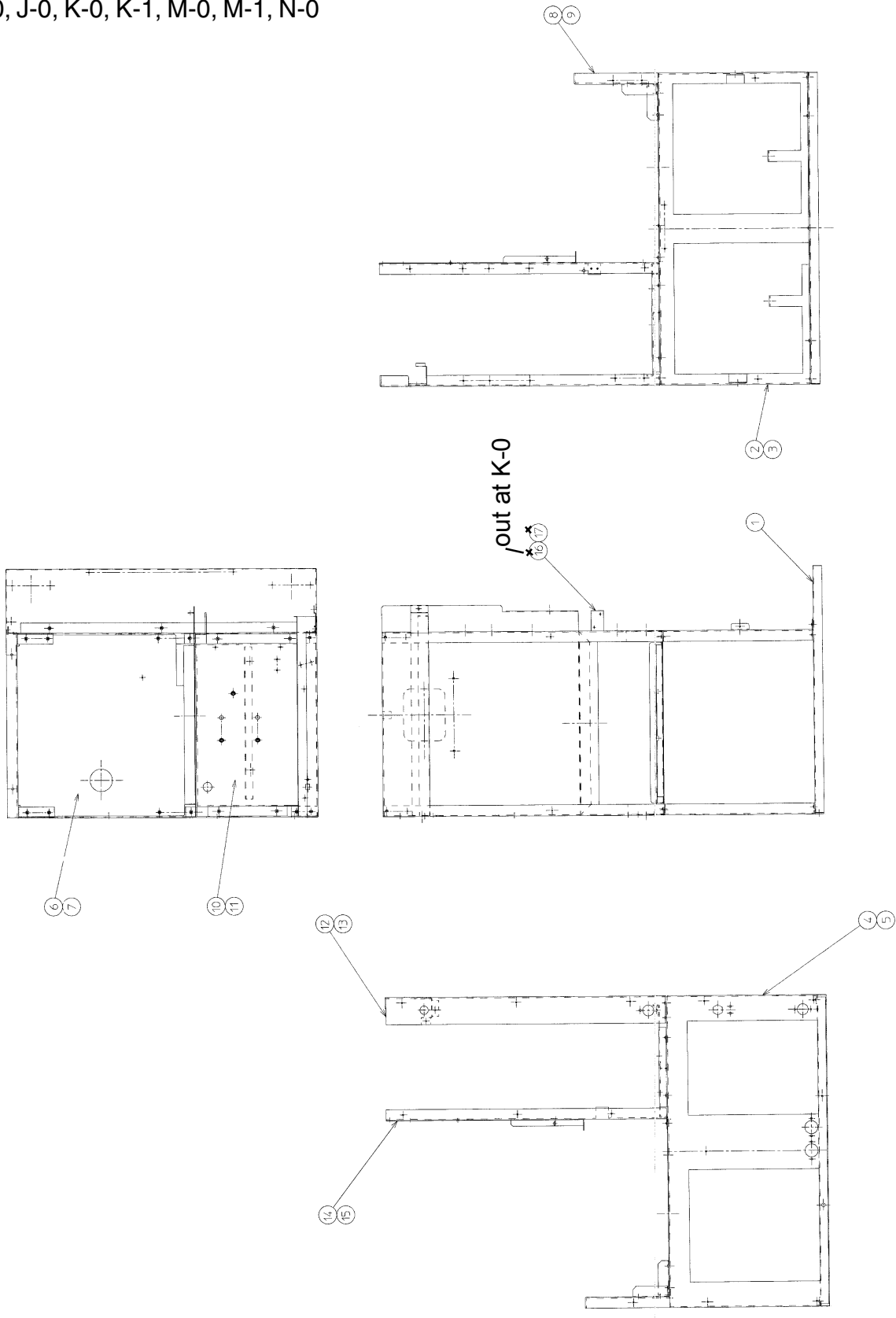

HA

Title: B. Frame Assembly Model: DCM-750BWF												
Index No.	Description	Material or Model Number	Part Number	Required Number								
				H-0 J-0	K-0 K-1	M-0	M-1	N-0				
1	BASE	-	3A1420G01	1	1	1	1	1				
2	FRONT FRAME	-	228446G01	1	1	1	1	1				
3	TRUSS HEAD SCREW	4X8	7P31-0408	5	5	5	5	5				
4	REAR FRAME	-	228447-01	1	1	1	1	1				
5	TRUSS HEAD SCREW	4X8	7C31-0408	3	3	3	3	3				
6	SEPARATOR	-	340973-01	1	1	1	1	1				
7	TRUSS HEAD SCREW	4X8	7C31-0408	2	2	2	2	2				
8	SIDE FRAME (R)	-	340974G01	1	1	1	1	1				
9	TRUSS HEAD	4X8	7C31-0408	4	4	4	4	4				
10	BRACKET – GEAR MOTOR	-	340975G01	1	1	1	1	1				
11	TRUSS HEAD SCREW	4X8	7C31-0408	4	4	4	4	4				
12	SIDE FRAME (UPPER)	-	340976G01	1	1	1	1	1				
13	TRUSS HEAD SCREW	4X8	7C31-0408	3	3	3	3	3				
14	CENTER PANEL	-	340977G01	1	1	1	1	1				
15	TRUSS HEAD SCREW	4X8	7C31-0408	2	2	2	2	2				
16	BRACKET	-	4A1548-01	1	-							
17	TRUSS HEAD SCREW	4X8	7C31-0408	2	-							

HA

C. Evaporator Assembly

DCM-750BAF, DCM-750BWF

H-0, J-0, J-1, J-2, K-0, K-1, L-0, L-1, M-0, M-1, N-0

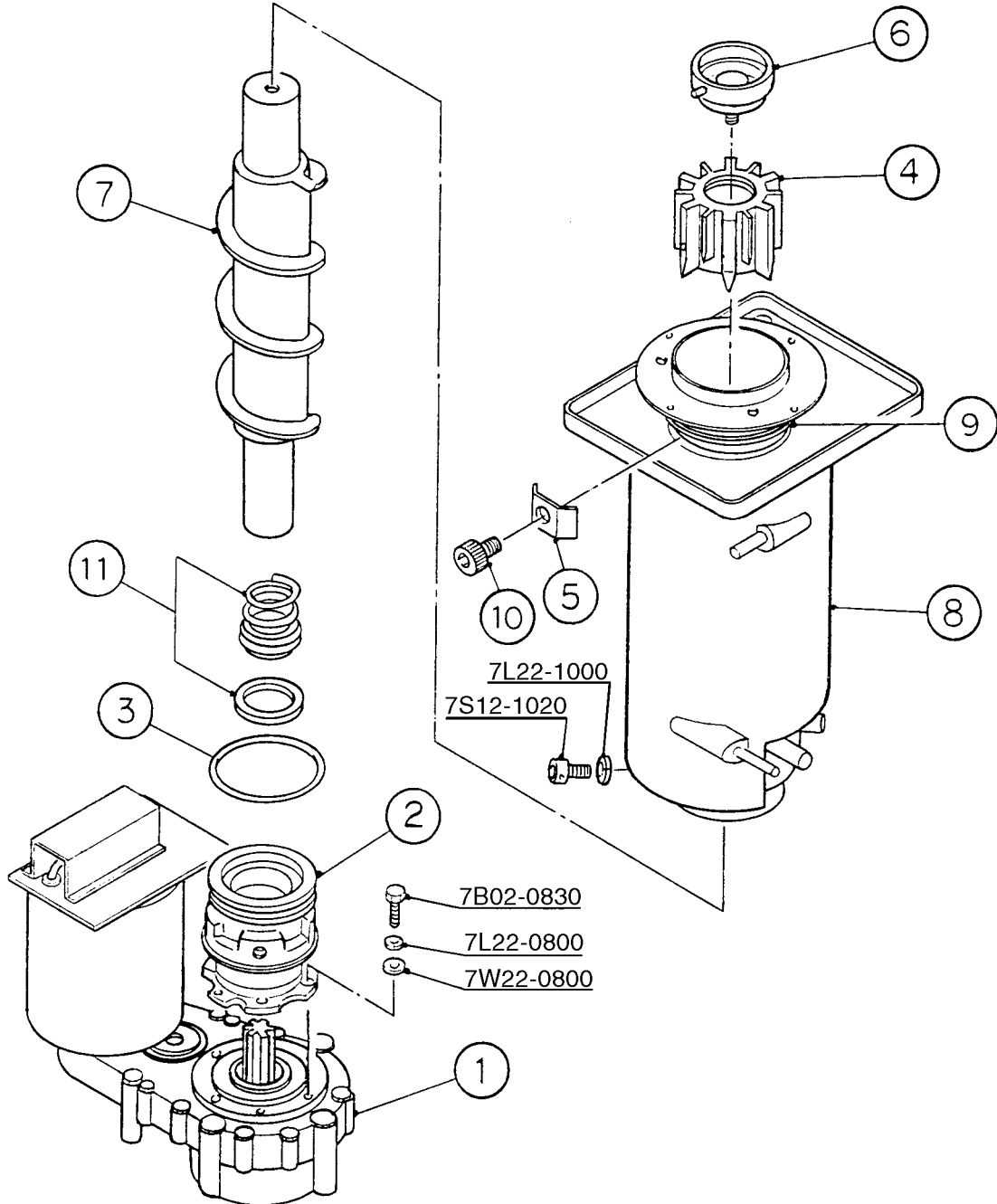

HA

Title: C. Evaporator Assembly Model: DCM-750BAF, DCM-750BWF												
Index No.	Description	Material or Model Number	Part Number	Required Number								
				H-0 J-0	J-1	J-2 K-0	K-1 L-0	L-1 M-0	M-1	N-0		
1	GEAR MOTOR		2U0077-01	1	1	1	1	1	1	1		
2	HOUSING		315732G02	1	1	1	1	1	1	1		
3	"O" RING	G90	7616-G090	2	2	2	2	2	2	2		
4	EXTRUDING HEAD – 95C	SS	2A1696G01	1	1	1	1	1	1	1		
5	WASHER	SS	425277-01	3	3	3	3	3	3	3		
6	CUTTER	SS	315736G01	1	1	1	1	1	1	1		
7	AUGER	SS	235266G01	1	1	1	1	x1				
	AUGER ASSEMBLY	SS	350941A01					o1	1	1		
	(AUGER)	-	236583G01					1	1	1		
	(BUSHING)	-	461840-01					1	1	1		
	(COUNTERSUNK SCREW)	-	4A2728-01					1	1	1		
8	EVAPORATOR		228206G01	1	1	1	1	1	1	1		
9	SILICON CORD HEATER		3U0097-01	1	1	1	1	1	1	1		
10	SOCKET HEAD CAP SCREW	SS, M10 X 15	429121-02	3	3	3	3	3	3	3		
11	MECHANICAL SEAL		432493-01	1	1	1	1	1	1	1		

HA

D. Refrigeration Circuit DCM-750BAF

H-0, J-0, J-1, J-2, K-0, K-1, L-0, L-1, M-0, N-0

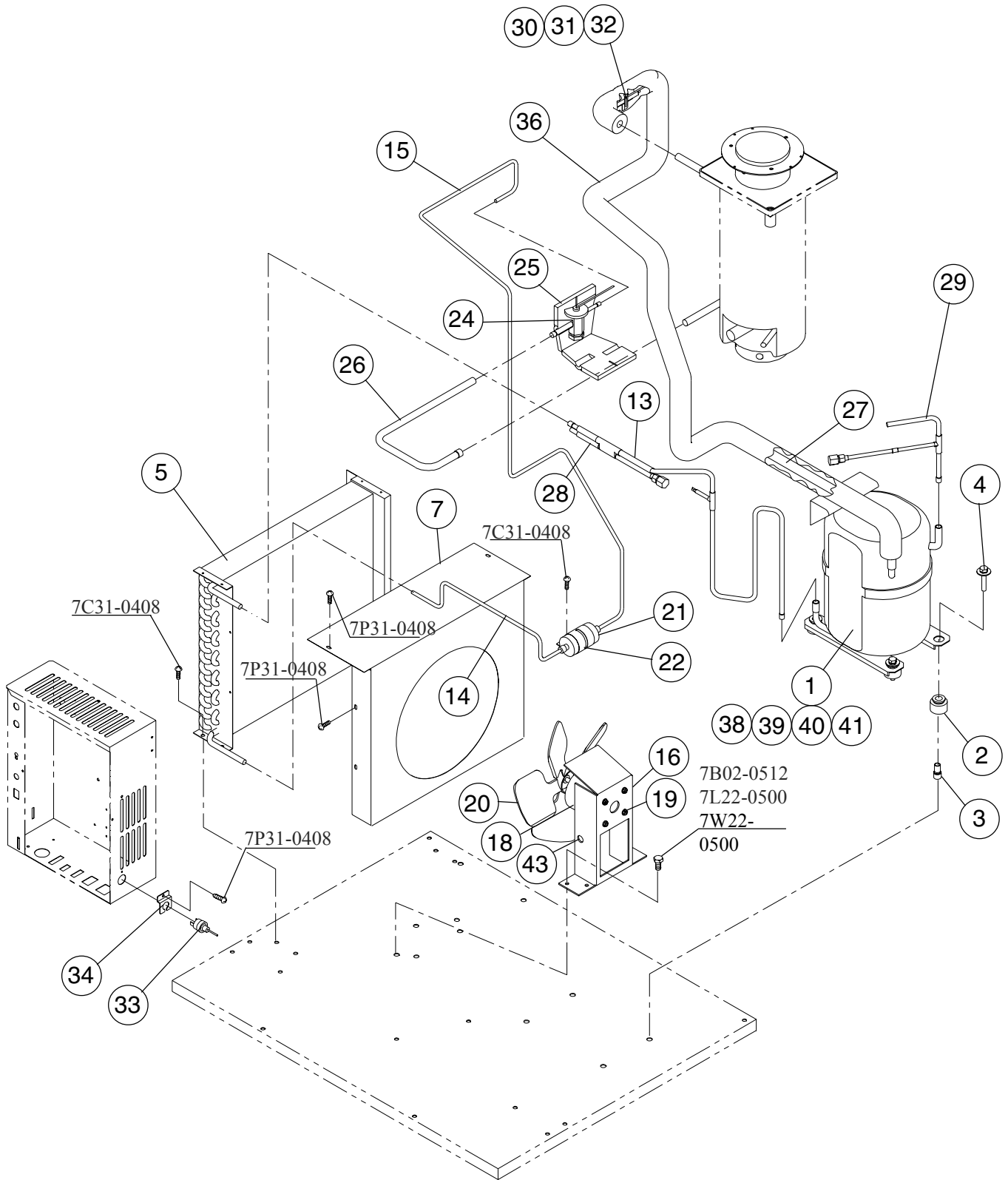

HA

Title: D. Refrigeration Circuit Model: DCM-750BAF												
Index No.	Description	Material or Model Number	Part Number	Required Number								
				H-0 J-0	J-1	J-2 K-0	K-1 L-0	L-1 M-0	N-0			
1	COMPRESSOR	RS55-CIE-PAA	4A1387-01	1	1	x1						
		RS55-C2E-CAA-219	4A1843-01			o1	1	1	1			
2	GROMMET		434403-01	4	4	4	4	4	4			
3	SPACER		434404-01	4	4	4	4	4	4			
4	BOLT		437889-01	4	4	4	4	4	4			
5	CONDENSER	602379C	3A0821-01	1	1	1	1	1	1			
	TRUSS HEAD SCREW	4 X 8	7C31-0408	3	3	3	3	3	3			
6	-		-	-								
7	SHROUD		340990-01	1	1	1	1	1	1			
	T2 SCREW	4 X 8	7P31-0408	6	6	6	6	6	6			
8	-		-	-								
9	-		-	-								
10	-		-	-								
11	-		-	-								
12	-		-	-								
13	COPPER TUBE (A) HIGH SIDE	COPPER	340992G01	1	1	1	1	1	1			
14	COPPER TUBE (B) HIGH SIDE	COPPER	454414-01	1	1	1	1	1	1			
15	COPPER TUBE (C) HIGH SIDE	COPPER	228463-01	1	1	1	1	1	1			
16	FAN MOTOR BRACKET		3A0650-01	1	1	1	1	1	1			
17	HEX HEAD BOLT W/WASHER (LF)	SS, 5 X 12	7B0230512	4	4	4	4	4	4			
	-		-	-								
18	FAN MOTOR		440911-01	1	1	1	1	1	1			
19	SELF-LOCKING NUT	No. 8-32	7N2110832	4	4	4	4	4	4			
20	FAN BLADE	AD10CW32	444898-01	1	1	1	1	1	1			
21	DRIER		4A1113-01	1	1	1	1	1	1			
22	DRIER BRACKET		445847-01	1	1	1	1	1	1			
	TRUSS HEAD SCREW	4 X 8	7C31-0408	1	1	1	1	1	1			
23	-		-	-								
24	EXPANSION VALVE		4A1117-01	1	1	1	1	1	1			
25	EXP. VALVE COVER		4A1168-01	1	1	1	1	1	1			
26	COPPER TUBE (B) LOW SIDE	COPPER	454415G01	1	1	1	1	1	1			
27	COPPER TUBE (A) LOW SIDE	COPPER	228464G01	1	1	1	1	1	1			
28	INSULATION TUBE	L=30	7762-1010	1	1	1	1	1	1			
29	COPPER TUBE - ACCESS VALVE	COPPER	453830G01	1	1	1	1	1	1			
30	CLAMP		443461-01	1	1	1	1	1	1			
31	HOLDER/EXP. VALVE - 1/2		3A0112-01	1	1	1	1	1	1			
32	CABLE TIE	CV-150	7920-0003	13	13	13	13	13	13			
33	PRESSURE SWITCH		433441-07	1	1	1	1	1	1			
34	PRESSURE SWITCH BRCKT.		434938-01	1	1	1	1	1	1			
	T2 SCREW	4 X 8	7P31-0408	1	1	1	1	1	1			
35	-		-	-								

HA

Title: D. Refrigeration Circuit Model: DCM-750BAF												
Index No.	Description	Material or Model Number	Part Number	Required Number								
				H-0 J-0	J-1	J-2 K-0	K-1 L-0	L-1 M-0	N-0			
36	INSULATION TUBE	L=130	7762-2943	1	1	1	1	1	1			
37	-		-	-								
38	TERMINAL COVER		4A1387F01	1	1	x1						
			4A1843F01			o1	1	1	1			
39	SPRING CLIP		4A1387F02	1	1	x1						
			4A1843F02			o1	1	1	1			
40	PROTECTOR		4A1387F03	1	1	x1						
			4A1843F03			o1	1	1	1			
41	PROTECTOR HOLDER		4A1387F04	1	1	x1						
			4A1843F04			o1	1	1	1			
42	INSULATION TUBE	L=500	7762-0717	1	1	1	1	1	1			
43	BUSHING		420470-09	1	1	1	1	1	1			

HA

D. Refrigeration Circuit

DCM-750BWF

H-0, J-0, K-0, K-1, M-0

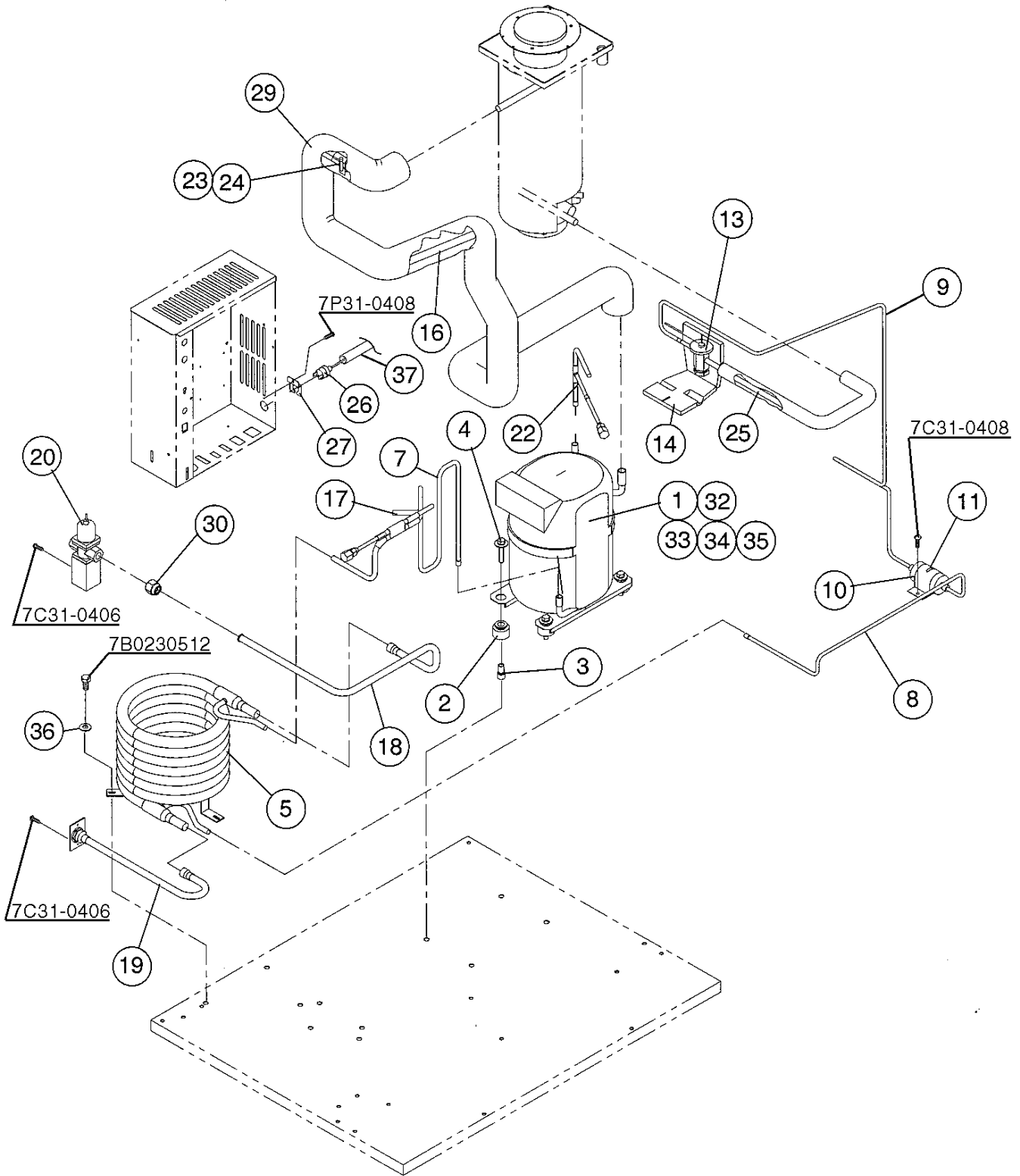

HA

D. Refrigeration Circuit

DCM-750BWF

M-1, N-0

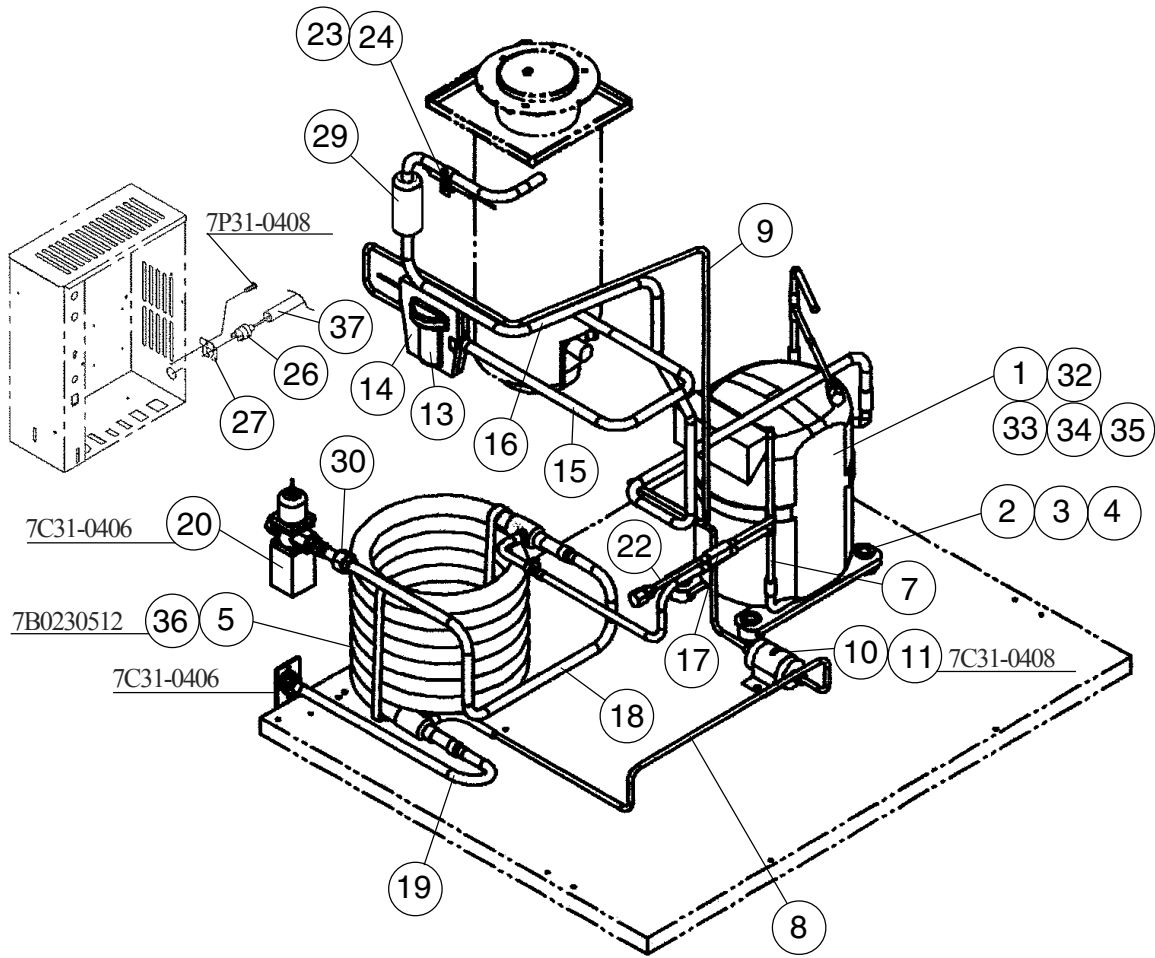

Title: D. Refrigeration Circuit Model: DCM-750BWF												
Index No.	Description	Material or Model Number	Part Number	Required Number								
				H-0 J-0	K-0	K-1	M-0	M-1	N-0			
1	COMPRESSOR	RS55-CIE-PAA	4A1387-01	1	x1							
		RS55-C2E-CAA-219	4A1843-01		o1	1	1	1	1			
2	GROMMET		434403-01	4	4	4	4	4	4			
3	SPACER		434404-01	4	4	4	4	4	4			
4	BOLT		437889-01	4	4	4	4	4	4			
5	CONDENSER - WATER COOLED	602379C	215545G01	1	1	1	1	-				
		-	2A2359G03					1	1			
	HEX HEAD BOLT W/WASHER (LF)	SS, 5 X 12	7B0230512	3	3	3	3	2	2			
6	-		-	-								
7	COPPER TUBE (A) HIGH SIDE	COPPER	340994G01	1	1	1	1	-				
		COPPER	3A2133G01					1	1			
8	COPPER TUBE (B) HIGH SIDE	COPPER	454419-01	1	1	1	1	-				
		COPPER	4A2645-01					1	1			
9	COPPER TUBE (C) HIGH SIDE	COPPER	228463-01	1	1	1	1	1	1			
10	DRIER		4A1113-01	1	1	1	1	1	1			
11	DRIER BRACKET		445847-01	1	1	1	1	1	1			
	TRUSS HEAD SCREW	4 X 8	7C31-0408	1	1	1	1	1	1			
12	-		-	-								
13	EXPANSION VALVE		4A1117-01	1	1	1	1	1	1			
14	EXP. VALVE COVER		4A1168-01	1	1	1	1	1	1			
15	COPPER TUBE (B) LOW SIDE	COPPER	454415G01	1	1	1	1	1	1			
16	COPPER TUBE (A) LOW SIDE	COPPER	228464G01	1	1	1	1	1	1			
17	INSULATION TUBE	L=30	7762-1010	1	1	1	1	1	1			
18	WATER TUBE (A)		340996G01	1	1	1	1	-				
			3A2134G01					1	1			
19	WATER TUBE (B)		454420G01	1	1	1	1	-				
			4A2646G01					1	1			
20	WATER REGULATOR		4A0911-04	1	1	1	1	1	1			
	TRUSS HEAD SCREW	4 X 6	7C31-0406	2	2	2	2	2	2			
21	-		-	-								
22	COPPER TUBE - ACCESS VALVE	COPPER	453830G01	1	1	1	1	1	1			
23	CLAMP		443461-01	1	1	1	1	1	1			
24	HOLDER/EXP. VALVE - 1/2		3A0112-01	1	1	1	1	1	1			
25	-		-	-								
26	PRESSURE SWITCH		433441-05	1	1	1	1	1	1			
27	PRESSURE SWITCH BRCKT.		434938-01	1	1	1	1	1	1			
	T2 SCREW	4 X 8	7P31-0408	1	1	1	1	1	1			
28	-		-	-	-	-	-	-	-			
29	INSULATION TUBE	L=130	7762-2943	1	1	1	1	1	1			
30	MALE CONNECTOR		4A1087-01	1	1	1	1	1	1			

HA

Title: D. Refrigeration Circuit Model: DCM-750BWF												
Index No.	Description	Material or Model Number	Part Number	Required Number								
				H-0 J-0	K-0	K-1	M-0	M-1	N-0			
31	-		-	-								
32	TERMINAL COVER		4A1387F01	1	x1							
			4A1843F01		o1	1	1	1	1			
33	SPRING CLIP		4A1387F02	1	x1							
			4A1843F02		o1	1	1	1	1			
34	PROTECTOR		4A1387F03	1	x1							
			4A1843F03		o1	1	1	1	1			
35	PROTECTOR HOLDER		4A1387F04	1	x1							
			4A1843F04		o1	1	1	1	1			
36	WASHER		4A0655-03	3	3	3	3	3	3			
37	INSULATION TUBE	L=500	7762-0717	1	1	1	1	-				
	VINYL HOSE	L=500	7711-0406					1	1			

HA

E. Water Circuit

DCM-750BAF, DCM-750BWF

H-0, J-0, J-1, J-2, K-0, K-1, L-0, L-1, M-0, M-1, N-0

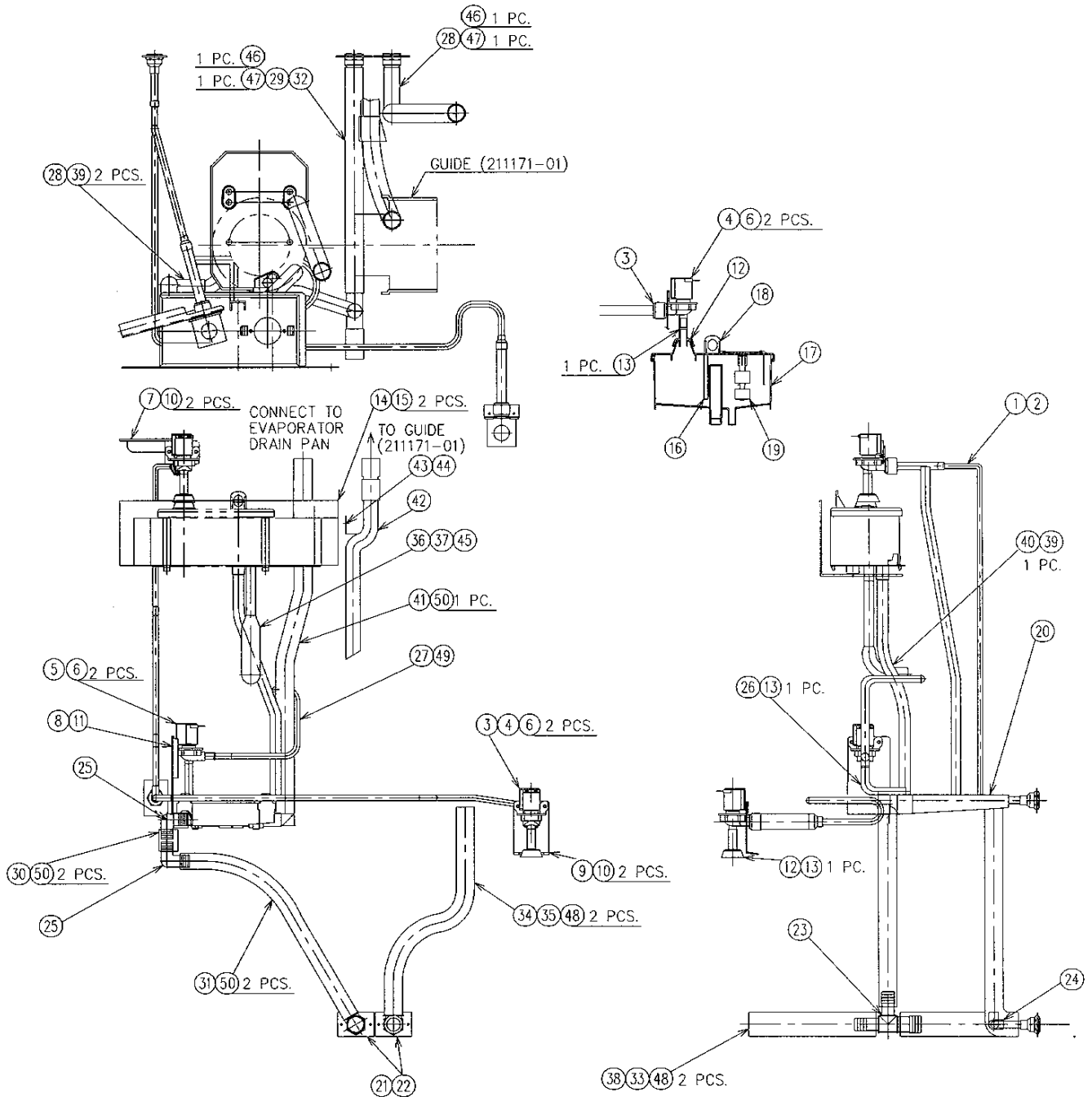

Title: E. Water Circuit Model: DCM-750BAF, DCM-750BWF												
Index No.	Description	Material or Model Number	Part Number	Required Number								
				H-0 J-0	J-1	J-2 K-0	K-1 L-0	L-1 M-0	M-1	N-0		
1	WATER SUPPLY PIPE		228452G01	1	1	1	1	1	1	1		
	T2 SCREW	4 X 8	7P31-0408	2	2	2	2	2	2	2		
2	-		-	-								
3	WASHER		4A0867-01	2	2	2	2	2	2	2		
4	WATER VALVE		4A0865-01	2	2	2	2	2	2	2		
5	WATER VALVE		4A0866-01	1	1	x1						
			4A2077-01			o1	1	x1				
			4A2772-01					o1	1	1		
	T2 SCREW	4 X 8	7P31-0408	6	6	6	6	6	6	6		
6	-		-	-								
7	WATER VALVE BRACKET (A)		454401-01	1	1	1	1	1	1	1		
8	WATER VALVE BRACKET (B)		454402-01	1	1	1	1	1	1	1		
9	WATER VALVE BRACKET (C)		4A0999-01	1	1	1	1	1	1	1		
	T2 SCREW	4 X 8	7P31-0408	4	4	4	4	4	4	4		
	TRUSS HEAD SCREW	4 X 8	7C31-0408	2	2	2	2	2	2	2		
10	-		-	-								
11	-		-	-								
12	INLET - RESERVOIR		4A0869-01	1	1	1	1	1	1	1		
13	CLAMP		421642-04	5	5	5	5	4	4	4		
14	BRACKET - RESERVOIR		340982-01	1	1	1	1	1	1	1		
	TRUSS HEAD SCREW	4 X 8	7C31-0408	2	2	2	2	2	2	2		
15	-		-	-								
16	SEPARATOR - RESERVOIR		4A1255-01	1	1	1	1	1	1	1		
17	RESERVOIR		2A0753-01	1	1	1	1	1	1	1		
18	RESERVOIR COVER		214810-01	1	1	1	1	1	1	1		
19	FLOAT SWITCH		435490-01	1	1	1	1	1	1	1		
20	DRAIN PAN		323765G02	1	1	1	1	1	1	1		
21	FITTING		4A0776G01	2	2	2	2	2	2	2		
	T2 SCREW	4 X 8	7P31-0408	4	4	4	4	4	4	4		
22	-		-	-								
23	TEE		4A0525-04	1	1	1	1	1	1	1		
24	ELBOW		4A1016-01	1	1	1	1	1	1	1		
25	ELBOW		4A1017-01	2	2	2	2	2	2	2		
26	VINYL HOSE	L=120	7716-0913	1	1	1	1	1	1	1		
27	VINYL HOSE	L=340	7725-0912	1	1	1	1	x1				
	SILICONE HOSE	L=340	7730I3896					o1	1	1		
28	VINYL HOSE	L=70	7716-2025	1	1	1	1	1	1	1		
29	INSULATION TUBE	L=380	7762-2943	1	1	1	1	1	1	1		
30	VINYL HOSE	L=50	7725-1923	1	1	1	1	1	1	1		
31	VINYL HOSE	L=500	7725-1923	1	1	1	1	1	1	1		
32	VINYL HOSE	L=320	7725-2025	1	1	1	1	1	1	1		
33	VINYL HOSE	L=125	4A0658L01	1	1	1	1	1	1	1		
34	VINYL HOSE	L=485	4A0658L01	1	1	1	1	1	1	1		
35	INSULATION TUBE	L=500	7762-2943	1	1	1	1	1	1	1		
36	HOSE (A8) WATER SUPPLY		428615-08	1	1	1	1	1	1	1		
37	HOSE CLAMP		435934-06	1	1	1	1	1	1	1		
38	INSULATION TUBE	L=130	7762-2943	1	1	1	1	1	1	1		
39	CABLE TIE		7920-0003	18	2	2	2	2	2	2		
40	VINYL HOSE	L=460	7725-1923	1	1	1	1	1	1	1		

HA

Title: E. Water Circuit Model: DCM-750BAF, DCM-750BWF												
Index No.	Description	Material or Model Number	Part Number	Required Number								
				H-0 J-0	J-1	J-2 K-0	K-1 L-0	L-1 M-0	M-1	N-0		
41	VINYL HOSE	L=630	7725-1923	1	1	1	1	1	1	1	1	
42	PIPE - DRAIN		320836-01	1	1	1	1	1	1	1	1	
43	BRACKET		432496-01	1	1	1	1	1	1	1	1	
44	THUMBSCREW		415949G04	1	1	1	1	1	1	1	1	
45	HOSE CLAMP		435934-07	1	1	1	1	1	1	1	1	
46	HOSE CLAMP		4A2017-01		9	9	9	2	2	2	2	
47	HOSE CLAMP		4A2017-02		2	2	2	2	2	2	2	
48	HOSE CLAMP		4A2017-03		4	4	4	4	4	4	4	
49	CLAMP		421642-04		1	1	1	1	1	1	1	
50	HOSE CLAMP		4A2017-09					7	7	7	7	

HA

F. Middle Front Panel Assembly DCM-750BAF, DCM-750BWF

H-0, J-0, J-1, J-2, K-0, K-1, L-0, L-1, M-0, M-1, N-0

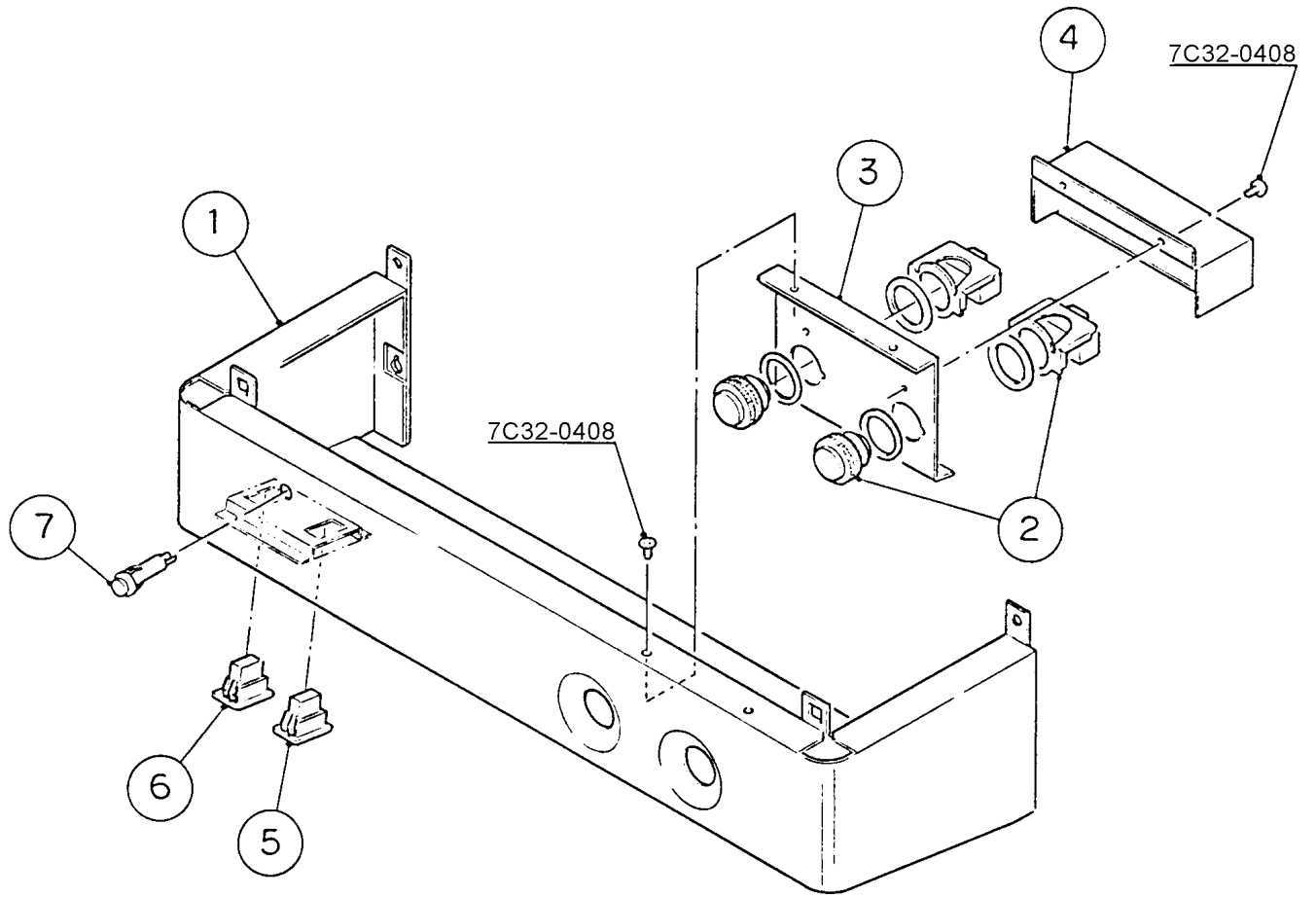

HA

Title: F. Middle Front Panel Assembly Model: DCM-750BAF, DCM-750BWF												
Index No.	Description	Material or Model Number	Part Number	Required Number								
				H-0 J-0	J-1	J-2 K-0	K-1 L-0	L-1 M-0	M-1	N-0		
1	MIDDLE FRONT PANEL		228458G02	1	1	1	1	1	1	1	1	
2	PUSH SWITCH		435745-02	2	2	2	2	2	2	2	2	
3	SWITCH BRACKET		4A0614-01	1	1	1	1	1	1	1	1	
	TRUSS HEAD SCREW	SS, 4 X 8	7C32-0408	4	4	4	4	4	4	4	4	
4	SWITCH COVER		4A1054-01	1	1	1	1	1	1	1	1	
	TRUSS HEAD SCREW	SS, 4 X 8	7C32-0408	2	2	2	2	2	2	2	2	
5	ROCKER SWITCH - DISPENSE		4A0558-01	1	1	1	1	1	1	1	1	
6	ROCKER SWITCH - ICE/FLUSH		4A1034-01	1	1	1	1	1	1	1	1	
7	LAMP		4A1821-01	1	1	1	1	x1				
			4A2672-01					o1	1	1		

HA

G. Bin Assembly

DCM-750BAF, DCM-750BWF

H-0, J-0, J-1, J-2, K-0

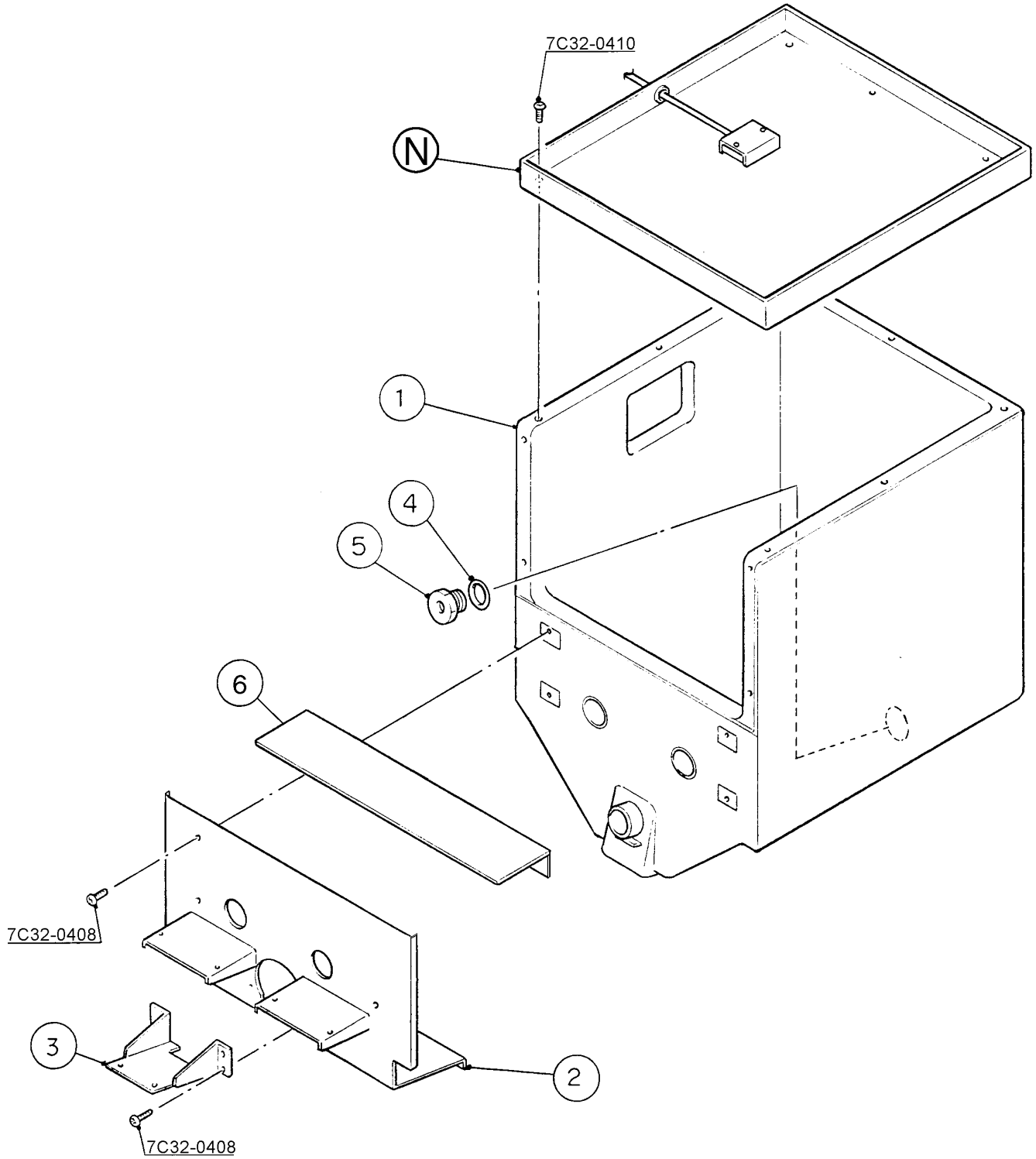

HA

G. Bin Assembly

DCM-750BAF, DCM-750BWF

K-1, L-0, L-1, M-0, M-1, N-0

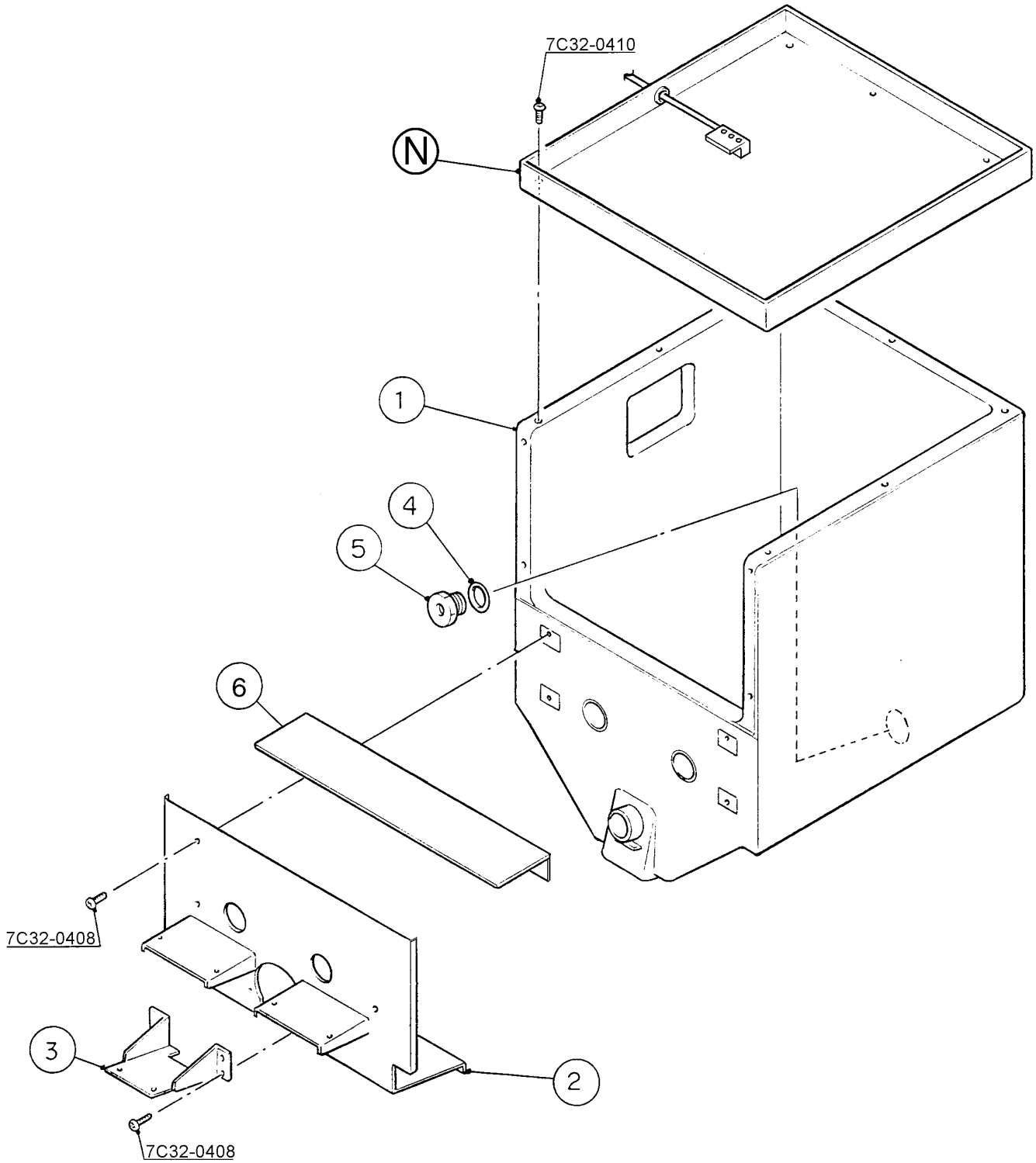

HA

Title: G. Bin Assembly Model: DCM-750BAF, DCM-750BWF												
Index No.	Description	Material or Model Number	Part Number	Required Number								
				H-0 J-0	J-1	J-2 K-0	K-1 L-0	L-1 M-0	M-1	N-0		
N	BIN TOP ASSEMBLY	-	340983A01	1	1	1	-					
		-	3A1561A01				1	1	1	1		
	TRUSS HEAD SCREW	SS, 4 X 10	7C32-0410	7	7	7	7	7	7	7		
1	BIN - FORMED		104003G01	1	1	1	1	1	1	1		
2	BARRIER		228453G01	1	1	1	1	1	1	1		
	TRUSS HEAD SCREW	SS, 4 X 8	7C32-0408	4	4	4	4	4	4	4		
3	BRACKET - SLIDING		340986-01	1	1	1	1	1	1	1		
	TRUSS HEAD SCREW	SS, 4 X 8	7C32-0408	4	4	4	4	4	4	4		
4	"O" RING		7616-P032	3	3	3	3	3	3	3		
5	SHAFT HOLDER (C)		429818-01	3	3	3	3	3	3	3		
6	BARRIER – MOTOR		340984-01	1	1	1	1	1	1	1		

HA

H. Gear Motor Assembly

DCM-750BAF, DCM-750BWF

H-0, J-0, J-1, J-2, K-0, K-1, L-0, L-1, M-0, M-1, N-0

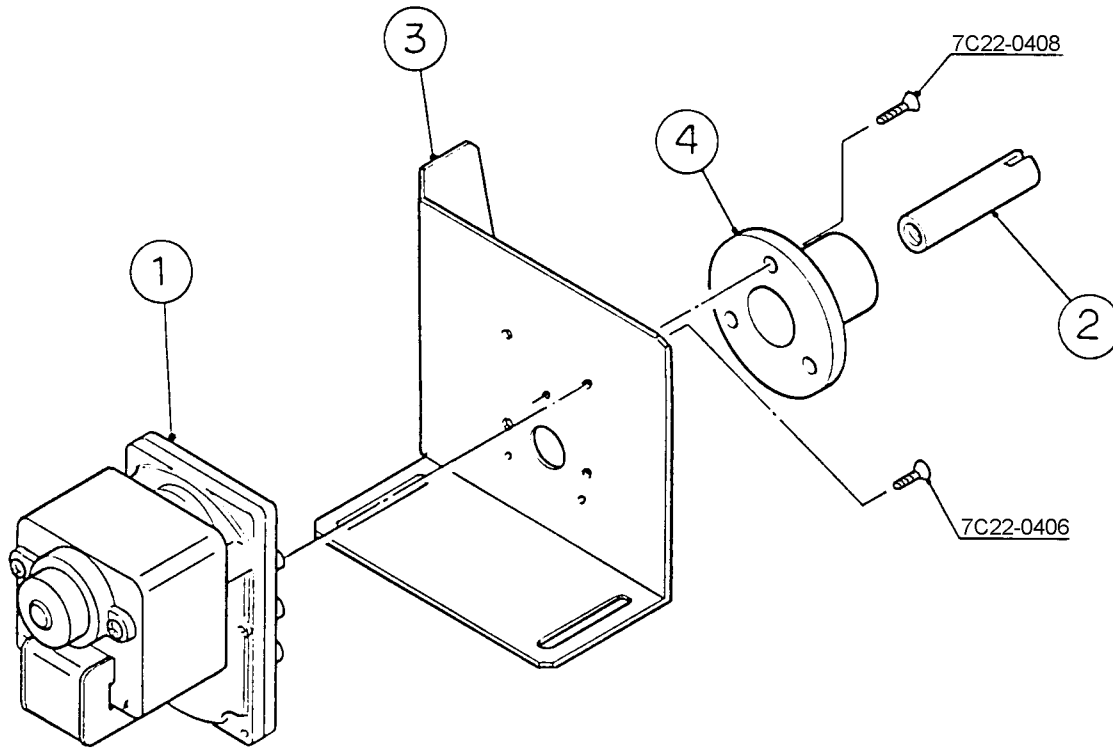

Title: H. Gear Motor Assembly Model: DCM-750BAF, DCM-750BWF												
Index No.	Description	Material or Model Number	Part Number	Required Number								
				H-0 J-0	J-1	J-2 K-0	K-1 L-0	L-1 M-0	M-1	N-0		
1	GEAR MOTOR		2U0080-04	1	1	1	1	1	1	1		
2	JOINT		429764-01	1	1	1	1	1	1	1		
3	BRACKET (C3) - GEAR MOTOR		340989-01	1	1	1	1	1	1	1		
	FLAT HEAD SCREW	SS, 4 X 6	7C22-0406	4	4	4	4	4	4	4		
4	PLASTIC SLEEVE (A)		429761-01	1	1	1	1	1	1	1		
	FLAT HEAD SCREW	SS, 4 X 8	7C22-0408	3	3	3	3	3	3	3		

HA

I. Gear Motor Assembly (L)
DCM-750BAF, DCM-750BWF

H-0, J-0, J-1, J-2, K-0, K-1, L-0, L-1, M-0, M-1, N-0

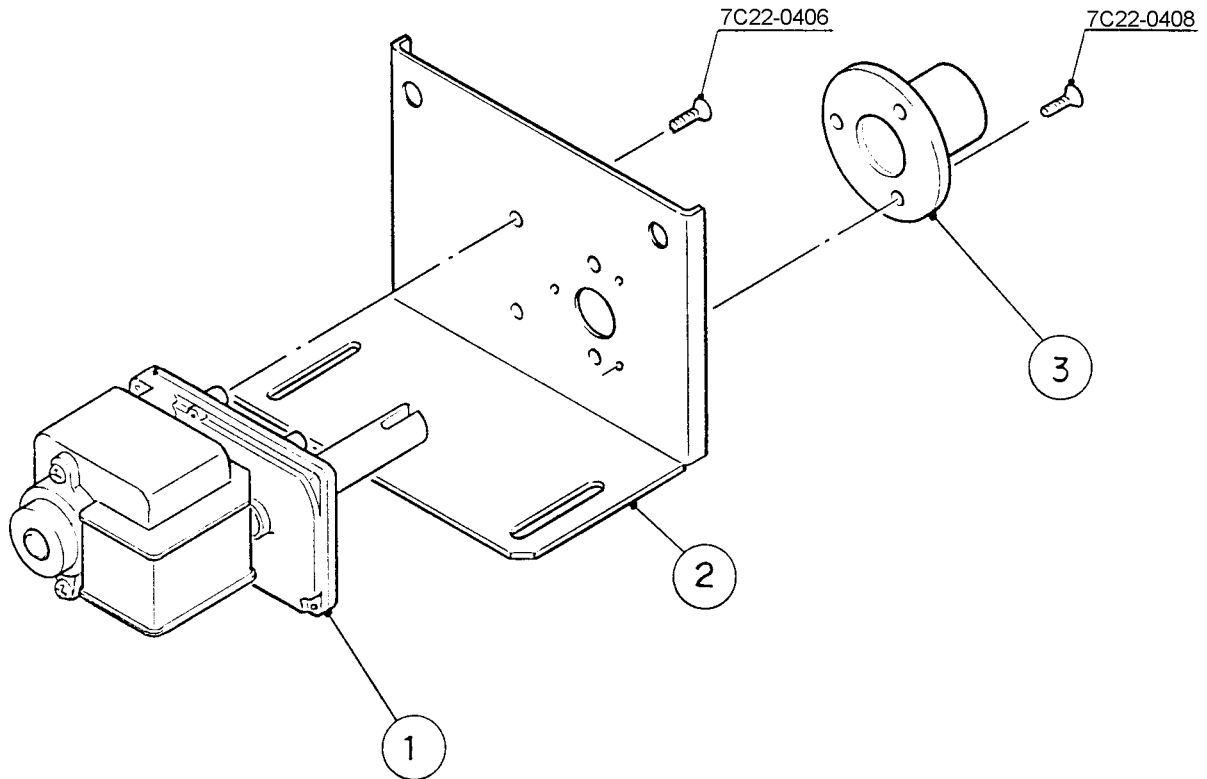

Title: I. Gear Motor Assembly (L) Model: DCM-750BAF, DCM-750BWF												
Index No.	Description	Material or Model Number	Part Number	Required Number								
				H-0 J-0	J-1	J-2 K-0	K-1 L-0	L-1 M-0	M-1	N-0		
1	GEAR MOTOR		2U0099-01	1	1	1	1	1	1	1		
2	BRACKET (L1) - GEAR MOTOR		454407-01	1	1	1	1	1	1	1		
	FLAT HEAD SCREW	SS, 4 X 6	7C22-0406	4	4	4	4	4	4	4		
3	PLASTIC SLEEVE (A)		429761-01	1	1	1	1	1	1	1		
	FLAT HEAD SCREW	SS, 4 X 8	7C22-0408	3	3	3	3	3	3	3		

HA

J. Gear Motor Assembly (R)
DCM-750BAF, DCM-750BWF

H-0, J-0, J-1, J-2, K-0, K-1, L-0, L-1, M-0, M-1, N-0

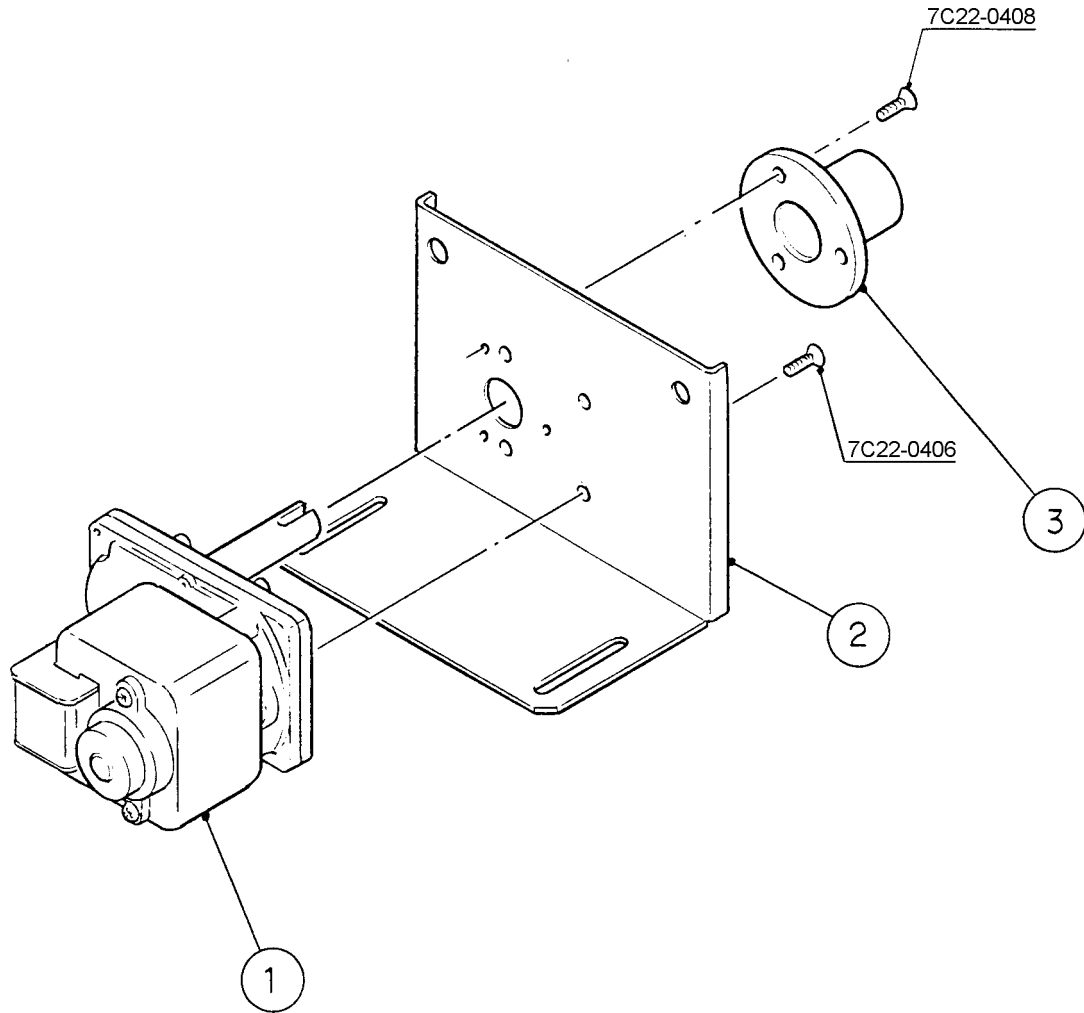

Title: J. Gear Motor Assembly (R) Model: DCM-750BAF, DCM-750BWF												
Index No.	Description	Material or Model Number	Part Number	Required Number								
				H-0 J-0	J-1	J-2 K-0	K-1 L-0	L-1 M-0	M-1	N-0		
1	GEAR MOTOR		2U0099-01	1	1	1	1	1	1	1		
2	BRACKET (R1) - GEAR MOTOR		454409-01	1	1	1	1	1	1	1		
	FLAT HEAD SCREW	SS, 4 X 6	7C22-0406	4	4	4	4	4	4	4		
3	PLASTIC SLEEVE (A)		429761-01	1	1	1	1	1	1	1		
	FLAT HEAD SCREW	SS, 4 X 8	7C22-0408	3	3	3	3	3	3	3		

HA

K. Shutter Assembly

DCM-750BAF, DCM-750BWF

H-0, J-0, J-1, J-2, K-0

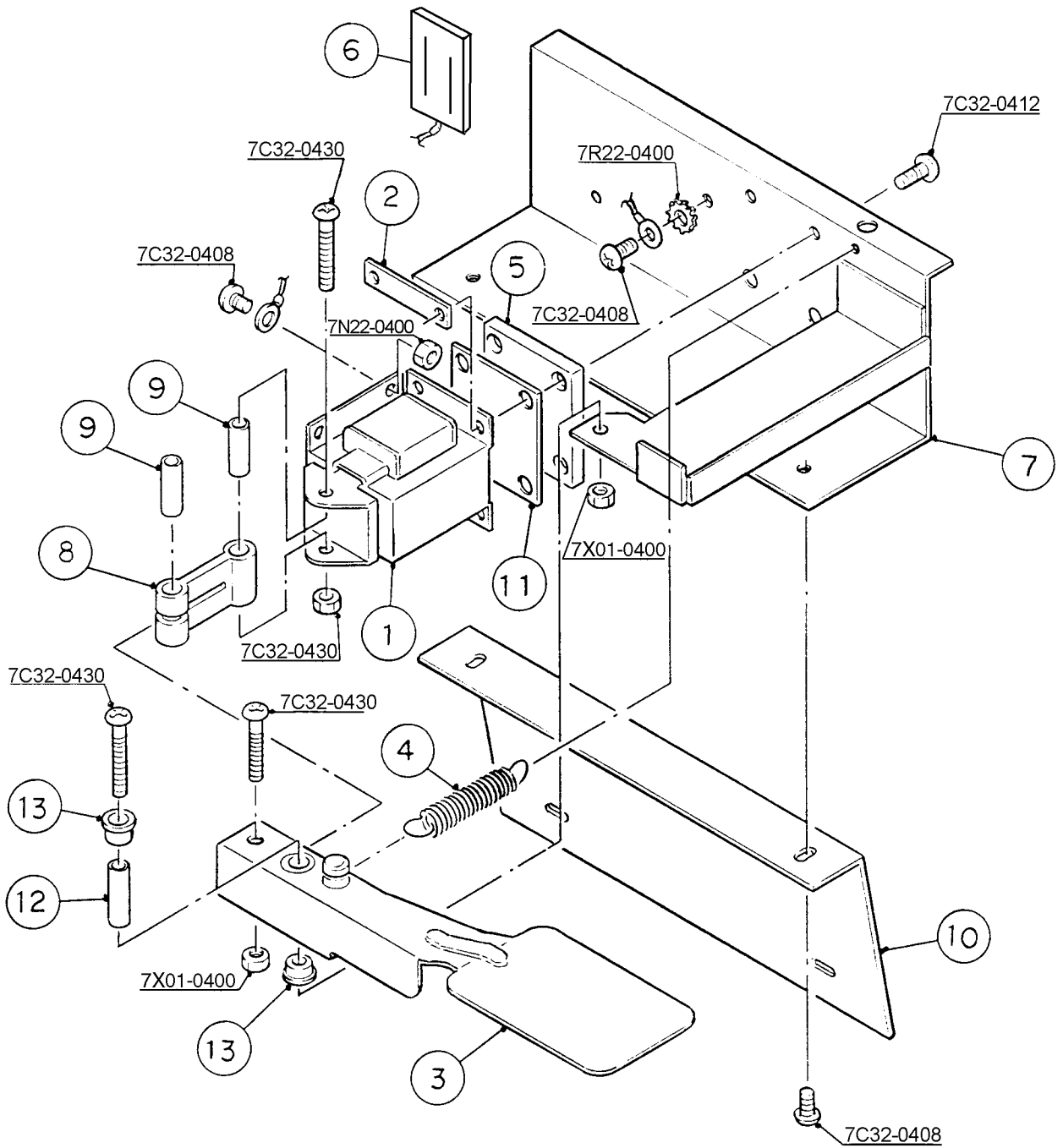

HA

K. Shutter Assembly

DCM-750BAF, DCM-750BWF

K-1, L-0, L-1, M-0, M-1, N-0

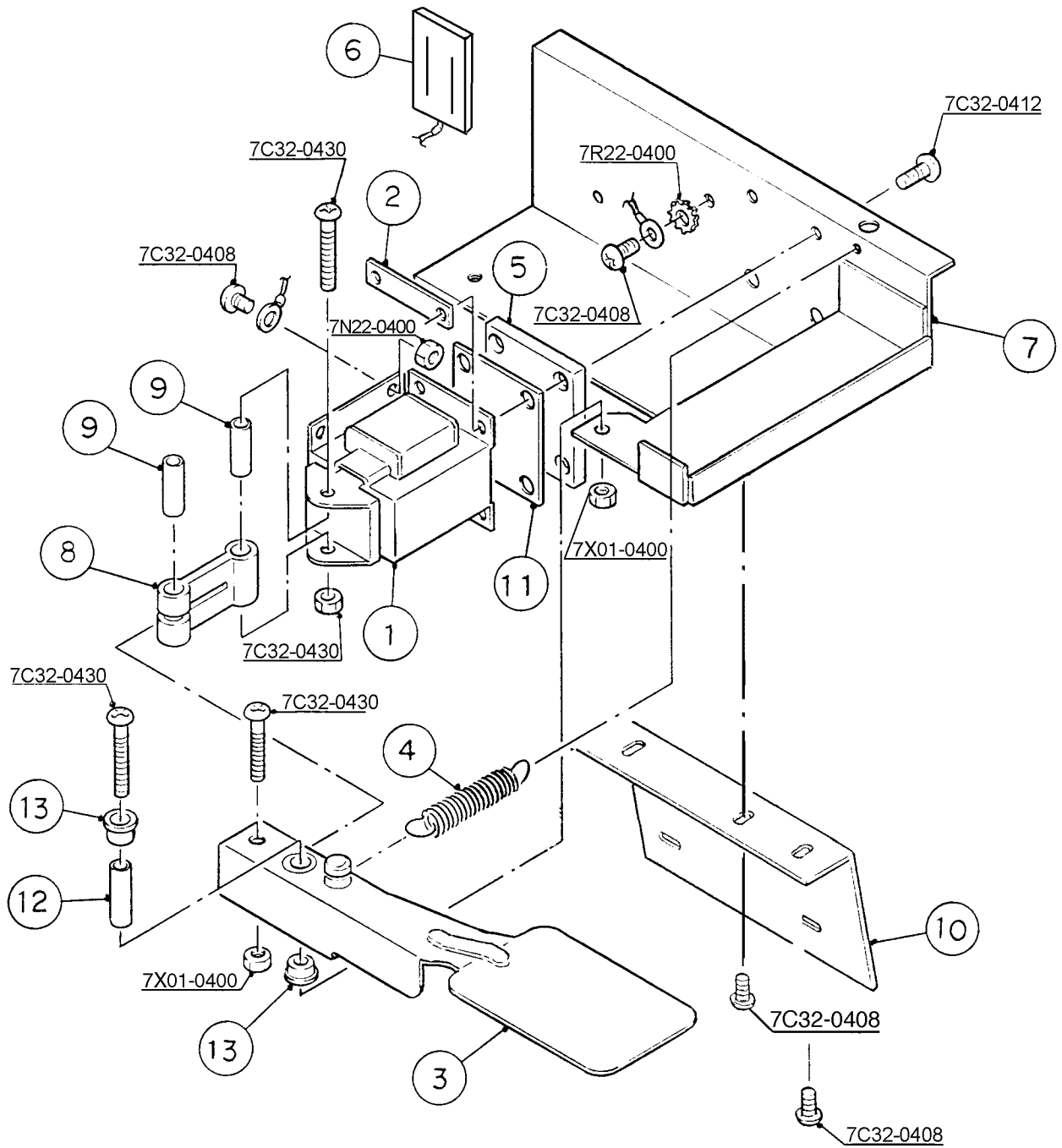

HA

Title: K. Shutter Assembly Model: DCM-750BAF, DCM-750BWF												
Index No.	Description	Material or Model Number	Part Number	Required Number								
				H-0 J-0	J-1	J-2 K-0	K-1 L-0	L-1 M-0	M-1	N-0		
1	SOLENOID		3U0095-01	1	1	1	1	1	1	1		
2	SOLENOID NUT	SS	429723-01	2	2	2	2	2	2	2		
3	LEVER	SS	318976G02	1	1	1	x1					
		SS	3A1653G01				o1	1	1	1		
4	SPRING	SS	432878-01	1	1	1	1	1	1	1		
5	SOLENOID PACKING	SY. R.	430380-01	1	1	1	1	1	1	1		
6	R-C CAPACITOR (NOISE SUPPRESSOR)		4A1012-01	1	1	1	1	1	1	1		
	TRUSS HEAD SCREW	SS, 4 X 8	7C32-0408	1	1	1	1	1	1	1		
	SELF-LOCKING NUT	SS, M4	7N22-0400	1	1	1	1	1	1	1		
	TOOTH WASHER	SS, M4	7R22-0400	1	1	1	1	1	1	1		
7	BASE - SHUTTER	SS	320906G02	1	1	1	-					
		SS	2A2030-01				1	1	1	1		
8	LINK	AC	432232-01	1	1	1	1	1	1	1		
9	COLLAR (D)	SS	432240-02	2	2	2	2	2	2	2		
	TRUSS HEAD SCREW	SS, 4X30	7C32-0430	3	3	3	3	3	3	3		
	U NUT	M4	7X01-0400	3	3	3	3	3	3	3		
10	BASE (B) - SHUTTER		341011-01	1	1	1	1	1	1	1		
	TRUSS HEAD SCREW	SS, 4 X 8	7C32-0408	2	2	2	2	2	2	2		
11	PACKING COVER		431623-01	1	1	1	1	1	1	1		
	TRUSS HEAD SCREW	SS, 4 X 12	7C32-0412	4	4	4	4	4	4	4		
12	COLLAR (E)		432240-02	1	1	1	1	1	1	1		
13	PLASTIC SLEEVE INSERT		432235-01	2	2	2	2	2	2	2		

HA

L. Control Box Assembly

DCM-750BAF, DCM-750BWF

H-0, J-0, J-1, J-2, K-0, K-1, L-0, L-1, M-0, M-1, N-0

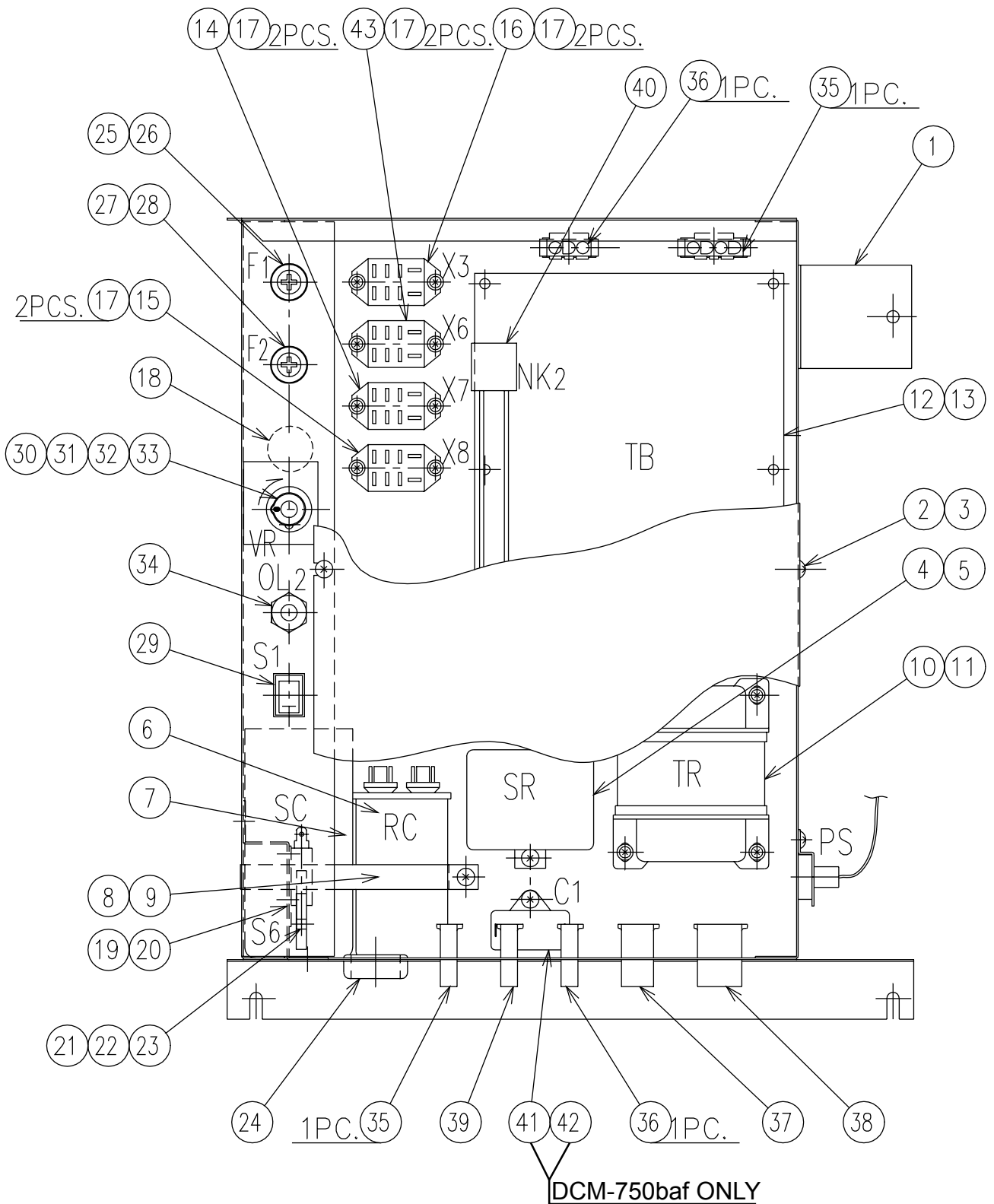

Title: L. Control Box Assembly Model: DCM-750BAF												
Index No.	Description	Material or Model Number	Part Number	Required Number								
				H-0 J-0	J-1	J-2	K-0 K-1	L-0 L-1	M-0	N-0		
1	CONTROL BOX		228456G01	1	-							
			2A1636G01		1	1	1	1	1	1	1	
2	COVER - CONTROL BOX		340987-01	1	1	1	1	1	1	1		
3	TRUSS HEAD SCREW	4 X 6	7C31-0406	2	2	2	2	2	2	2		
4	STARTER	-	4A0875-01	1	1	1	x1					
		-	4A1107-13				o1	1	1	1		
5	T2 SCREW	4 X 8	7P31-0408	1	1	1	1	1	1	1		
6	RUN CAPACITOR	X386S (HG02) 25µF	439943-02	1	1	1	1	x1				
		-	3A2005-06					o1	1	1		
7	CAPACITOR - STARTING	3535B5C0124 A220A2	3A0076-13	1	1	-						
		-	3A0076-12			1	1	1	1	1		
8	STRAP		434580-11	1	1	-						
			434580-12			1	1	x1				
			4A2262-03					o1	1	1		
9	T2 SCREW	4 X 8	7P31-0408	1	1	1	1	1	1	1		
10	TRANSFORMER	TR0082-1	2U0082-02	1	1	1	1	1	1	1		
11	T2 SCREW	4 X 8	7P31-0408	4	4	4	4	4	4	4		
12	TIMER BOARD		2U0098-02	1	-							
			2A1592-01		1	1	1	1	1	1		
13	BOARD SUPPORT	CBLS37-M	4A0336-03	6	4	4	4	4	4	4		
14	RELAY - HEATER CONTROL	LY1F 120VAC	418271-03	1	1	1	1	1	1	1		
15	RELAY - POWER PROTECT	LY1F-HSD 220/240VAC	418271-05	1	1	1	1	1	1	1		
16	RELAY - WATER CONTROL	LY2F 24VAC	406132-03	1	1	1	1	1	1	1		
17	TAPPING SCREW		431415-01	8	8	8	8	8	8	8		
18	BUSHING	SR-30-1	420472-03	1	1	1	1	1	1	1		
19	SWITCH BRACKET		4A1013-01	1	1	1	1	1	1	1		
20	T2 SCREW	4 X 8	7P31-0408	2	2	2	2	2	2	2		
21	MICROSWITCH	V3L-111-D8	4A0365-01	1	1	1	1	1	x1			
		-	4A2546-01						o1	1		
22	SPACER		429933-01	1	1	1	1	1	1	1		
23	TAPPING SCREW		4331415-02	2	2	2	2	2	2	2		
24	BUSHING	SB-1093-15	420470-03	1	1	1	1	1	1	1		
25	FUSE HOLDER	HTB921	4A0892-01	1	1	1	1	1	1	1		
26	FUSE	AGC-3	4A0893-03	1	1	1	1	1	1	1		
27	FUSE HOLDER	HTB92M	4A0892-02	1	1	1	1	1	1	1		
28	FUSE	GM-500mA 250V	4A0893-02	1	1	1	1	1	1	1		
29	ROCKER SWITCH - POWER	62111929-0-0- N	4A0558-01	1	1	1	1	1	1	1		
30	VARIABLE RESISTOR	EWHSAP15 B15	432858-01	1	1	1	1	1	1	1		
31	SPACER		439775-01	1	-							
32	LABEL - CONTROL		432845-01	1	-							
33	KNOB		318744-01	1	-							
34	PROTECTOR	W58xB1A4A-4	425201-02	1	1	1	1	1	1	1		
35	4P PLUG HOUSING	3191-04P	412832-05	2	2	2	2	2	2	2		

HA

Title: L. Control Box Assembly Model: DCM-750BAF												
Index No.	Description	Material or Model Number	Part Number	Required Number								
				H-0 J-0	J-1	J-2	K-0 K-1	L-0 L-1	M-0	N-0		
36	3P PLUG HOUSING	3191-03P	412832-06	2	2	2	2	2	2	2		
37	6P PLUG HOUSING	3191-06P	412832-03	1	1	1	1	1	1	1		
38	9P PLUG HOUSING	3191-09P	412832-02	1	1	1	1	1	1	1		
39	2P PLUG HOUSING	3191-02P	412832-07	1	1	1	1	1	1	1		
40	R-C CAPACITOR (NOISE SUPPRESSOR)	HG100	4A1012-01	1	1	1	1	1	1	1		
41	CAPACITOR	UP25B505UE F 5.0μF	443192-02	1	1	1	1	1	1	1		
42	T2 SCREW	4 X 8	7P31-0408	1	1	1	1	1	1	1		
43	RELAY - GEAR MOTOR PROTECT	LYZF AC120V	406132-07	1	1	1	1	1	1	1		

HA

Title: L. Control Box Assembly Model: DCM-750BWF													
Index No.	Description	Material or Model Number	Part Number	Required Number									
				H-0 J-0	K-0	K-1	M-0	M-1	N-0				
1	CONTROL BOX		228456G01	1	-								
			2A1636G01		1	1	1	1	1	1			
2	COVER - CONTROL BOX		340987-01	1	1	1	1	1	1				
3	TRUSS HEAD SCREW	4 X 6	7C31-0406	2	2	2	2	2	2				
4	STARTER	-	4A0875-01	1	1	x1							
		-	4A1107-13			o1	1	1	1				
5	T2 SCREW	4 X 8	7P31-0408	1	1	1	1	1	1				
6	RUN CAPACITOR	X386S (HG02) 25µF	439943-02	1	1	1	x1						
		-	3A2005-06				o1	1	1				
7	CAPACITOR - STARTING	3535B5C0124 A220A2	3A0076-13	1	-								
		-	3A0076-12		1	1	1	1	1	1			
8	STRAP		434580-11	1	-								
			434580-12		1	1	x1						
			4A2262-03				o1	1	1				
9	T2 SCREW	4 X 8	7P31-0408	1	1	1	1	1	1				
10	TRANSFORMER	TR0082-1	2U0082-02	1	1	1	1	1	1				
11	T2 SCREW	4 X 8	7P31-0408	4	4	4	4	4	4				
12	TIMER BOARD		2U0098-02	1	-								
			2A1592-01		1	1	1	1	1	1			
13	BOARD SUPPORT	CBLS37-M	4A0336-03	6	4	4	4	4	4				
14	RELAY - HEATER CONTROL	LY1F 120VAC	418271-03	1	1	1	1	1	1				
15	RELAY - POWER PROTECT	LY1F-HSD 220/240VAC	418271-05	1	1	1	1	1	1				
16	RELAY - WATER CONTROL	LY2F 24VAC	406132-03	1	1	1	1	1	1				
17	TAPPING SCREW		431415-01	8	8	8	8	8	8				
18	BUSHING	SR-30-1	420472-03	1	1	1	1	1	1				
19	SWITCH BRACKET		4A1013-01	1	1	1	1	1	1				
20	T2 SCREW	4 X 8	7P31-0408	2	2	2	2	2	2				
21	MICROSWITCH	V3L-111-D8	4A0365-01	1	1	1	x1						
		-	4A2546-01				o1	1	1				
22	SPACER		429933-01	1	1	1	1	1	1				
23	TAPPING SCREW		4331415-02	2	2	2	2	2	2				
24	BUSHING	SB-1093-15	420470-03	1	1	1	1	1	1				
25	FUSE HOLDER	HTB921	4A0892-01	1	1	1	1	1	1				
26	FUSE	AGC-3	4A0893-03	1	1	1	1	1	1				
27	FUSE HOLDER	HTB92M	4A0892-02	1	1	1	1	1	1				
28	FUSE	GM-500mA 250V	4A0893-02	1	1	1	1	1	1				
29	ROCKER SWITCH - POWER	62111929-0-0- N	4A0558-01	1	1	1	1	1	1				
30	VARIABLE RESISTOR	EWHSAP15 B15	432858-01	1	1	1	1	1	1				
31	SPACER		439775-01	1	-								
32	LABEL - CONTROL		432845-01	1	-								
33	KNOB		318744-01	1	-								
34	PROTECTOR	W58xB1A4A-4	425201-02	1	1	1	1	1	1				

HA

Title: L. Control Box Assembly Model: DCM-750BWF												
Index No.	Description	Material or Model Number	Part Number	Required Number								
				H-0 J-0	K-0	K-1	M-0	M-1	N-0			
35	4P PLUG HOUSING	3191-04P	412832-05	2	2	2	2	2	2			
36	3P PLUG HOUSING	3191-03P	412832-06	2	2	2	2	2	2			
37	6P PLUG HOUSING	3191-06P	412832-03	1	1	1	1	1	1			
38	9P PLUG HOUSING	3191-09P	412832-02	1	1	1	1	1	1			
39	2P PLUG HOUSING	3191-02P	412832-07	1	1	1	1	1	1			
40	R-C CAPACITOR (NOISE SUPPRESSOR)	HG100	4A1012-01	1	1	1	1	1	1			
41	-	-	-									
42	-	-	-									
43	RELAY - GEAR MOTOR PROTECT	LYZF AC120V	406132-07	1	1	1	1	1	1			

HA

M. Label Location

DCM-750BAF, DCM-750BWF

H-0, J-0, J-1, J-2, K-0, K-1, L-0, L-1, M-0, M-1, N-0

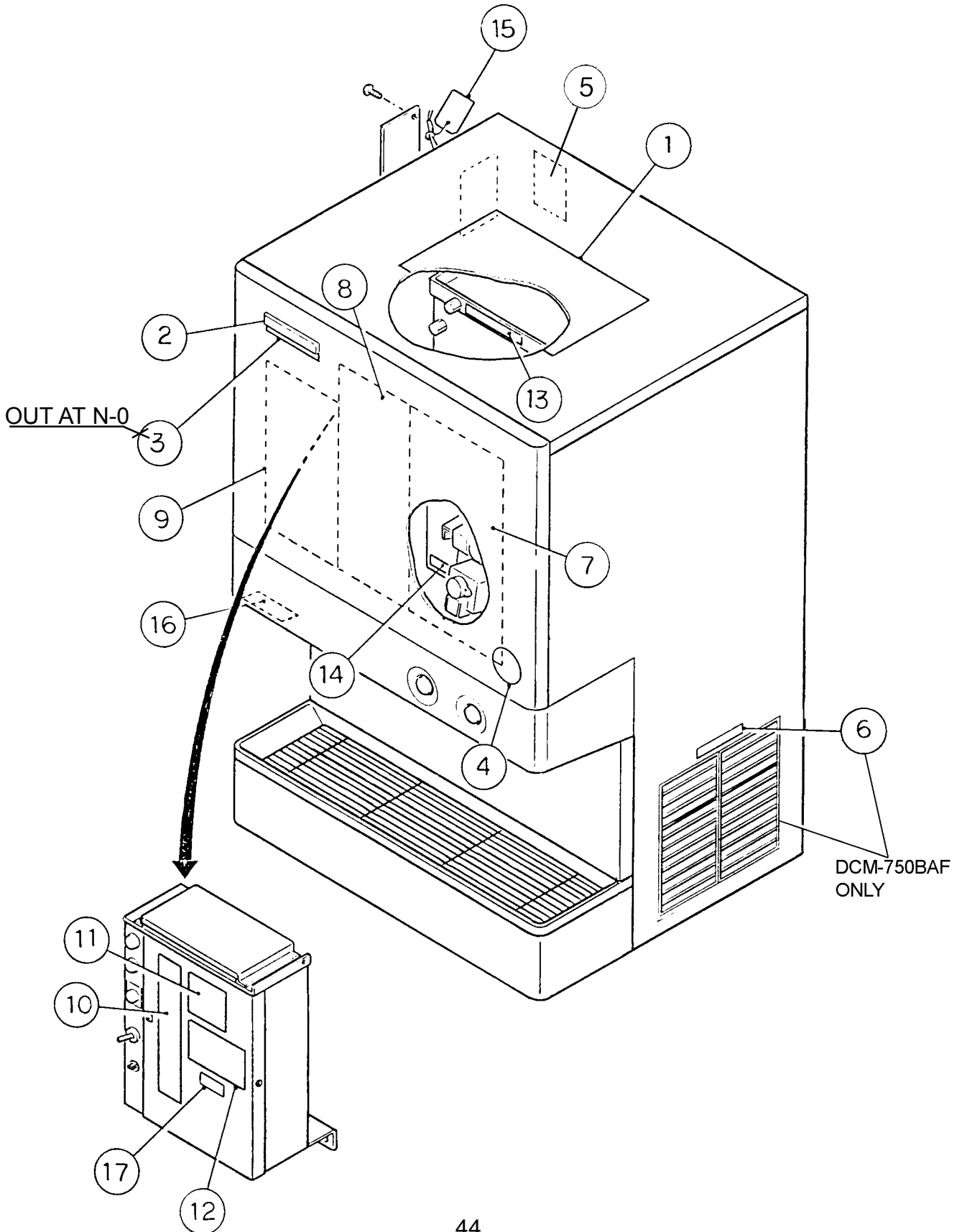

HA

Title: M. Label Location Model: DCM-750BAF												
Index No.	Description	Material or Model Number	Part Number	Required Number								
				H-0	J-0	J-1	J-2	K-0 K-1	L-0 L-1	M-0	N-0	
1	INSTRUCTION SHEET		2A0709-01	1	1	1	1	1	1	1	1	
2	EMBLEM		4A0560-01	1	1	1	1	1	1	1	1	
3	MODEL NUMBER LABEL		4A1321-27	1	1	1	1	1	1	1	-	
4	LABEL - PENGUIN - HA - L		4A0526-02	1	1	1	1	1	1	1	1	
5	NAMEPLATE		454411-01	1	1	1	1	1	1	1	x1	
			3A2530-01								o1	
6	LABEL - AIR FILTER		426177-01	1	1	-						
			2A1646-01			1	1	1	1	1	1	
7	INSTRUCTION LABEL		227630-01	1	1	1	1	1	1	1	1	
8	LABEL - CLEANING		2A0710-01	1	1	1	1	1	1	1	1	
9	WIRING LABEL		3A1174-01	1	-							
			3A1426-01		1	-						
			3A1458-01			1	-					
			3A1530-01				1	1	1	1	1	
10	LABEL - SWITCH, FUSE		439962-01	1	1	1	1	1	1	1	1	
11	RATING LABEL		4A1678-01	1	1	1	1	1	1	1	x1	
			3A2531-01								o1	
12	CAUTION LABEL (J)		439149-01	1	1	1	1	1	1	1	1	
13	LABEL-CAUTION: TOP PANEL		430439-01	1	1	1	1	1	1	1	1	
14	INSTRUCTION SHEET - BIN COVER		446463-01	1	1	1	1	1	1	1	1	
15	TAG - WARNING: ELECTRICAL CONNECTION		435005-01	1	1	1	1	1	1	1	1	
16	LABEL - SWITCH		4A1038-01	1	1	1	1	1	1	1	1	
17	LABEL - R404A		4A0960-01	1	1	1	1	1	1	1	1	

HA

Title: M. Label Location Model: DCM-750BWF												
Index No.	Description	Material or Model Number	Part Number	Required Number								
				H-0 J-0	K-0	K-1	M-0	M-1	N-0			
1	INSTRUCTION SHEET		2A0709-01	1	1	1	1	1	1	1		
2	EMBLEM		4A0560-01	1	1	1	1	1	1			
3	MODEL NUMBER LABEL		4A1321-28	1	1	1	1	1	-			
4	LABEL - PENGUIN - HA - L		4A0526-02	1	1	1	1	1	1			
5	NAMEPLATE		454412-01	1	1	1	1	-				
			4A2770-01					1	x1			
			3A2530-02						o1			
6	-		-									
7	INSTRUCTION LABEL		227630-01	1	-							
			2A1646-01		1	1	1	1	1	1		
8	LABEL - CLEANING		219705-01	1	1	1	1	1	1			
9	WIRING LABEL		3A1174-01	1	-							
			3A1530-01		1	1	1	1	1	1		
10	LABEL - SWITCH, FUSE		439962-01	1	1	1	1	1	1			
11	RATING LABEL		4A1679-01	1	1	1	1	-				
			4A2771-01					1	x1			
			3A2531-02						o1			
12	CAUTION LABEL (J)		439149-01	1	1	1	1	1	1			
13	LABEL-CAUTION: TOP PANEL		430439-01	1	1	1	1	1	1			
14	INSTRUCTION SHEET - BIN COVER		446463-01	1	1	1	1	1	1			
15	TAG - WARNING: ELECTRICAL CONNECTION		435005-01	1	1	1	1	1	1			
16	LABEL - SWITCH		4A1038-01	1	1	1	1	1	1			
17	LABEL - R404A		4A0960-01	1	1	1	1	1	1			

HA

N. Bin Top Assembly

DCM-750BAF, DCM-750BWF

H-0, J-0, J-1, J-2, K-0

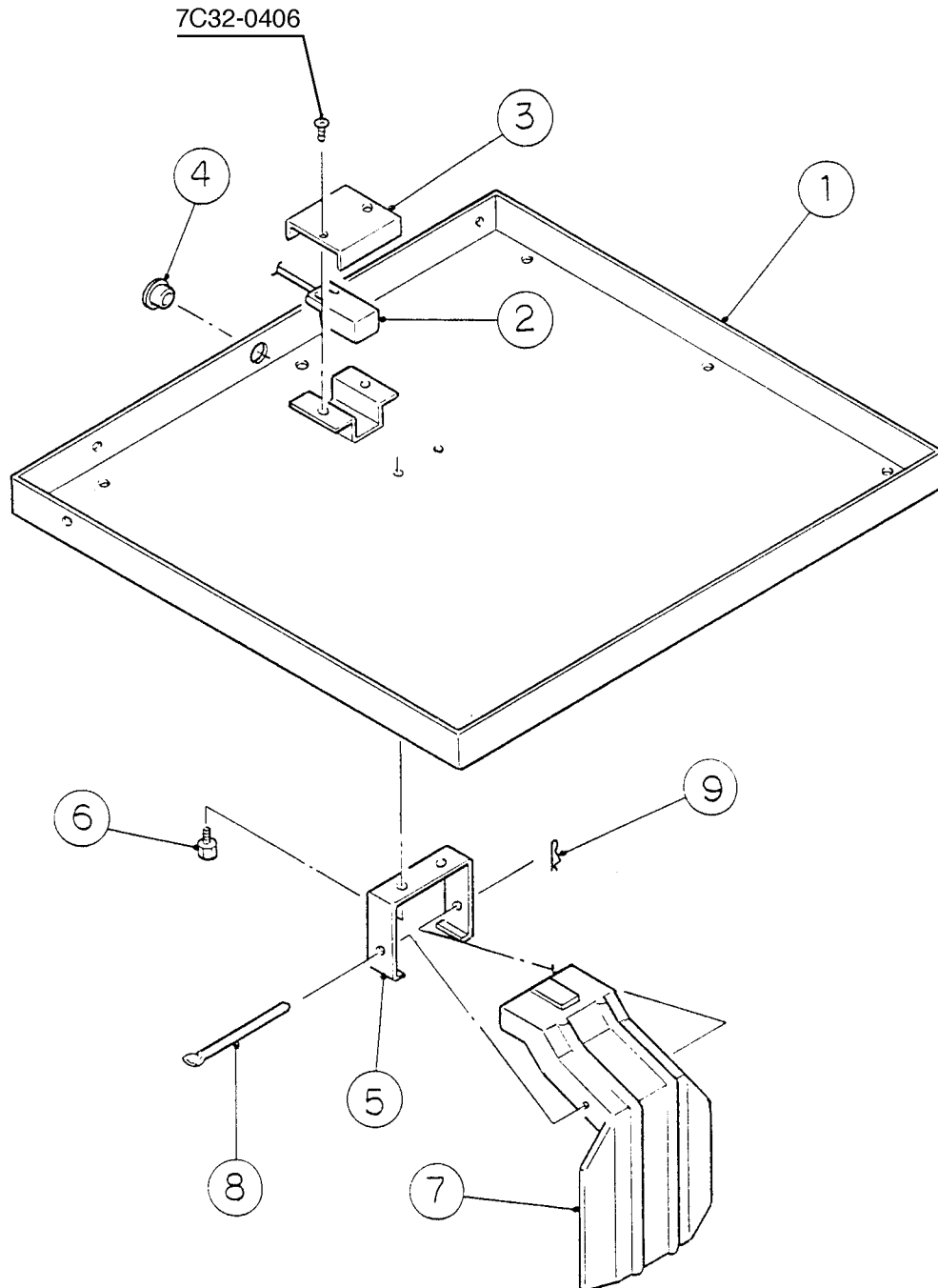

HA

Title: N. Bin Top Assembly Model: DCM-750BAF, DCM-750BWF												
Index No.	Description	Material or Model Number	Part Number	Required Number								
				H-0 J-0	J-1 J-2	K-0	K-1	L-0 L-1	M-0 M-1	N-0		
1	COVER - BIN TOP		211182G01	1	1	1	-					
			2A1713G01				1	1	1	1		
2	PROXIMITY - SWITCH		427223-01	1	1	1	-					
			4A2033-01				1	1	1	1		
3	BRACKET - SWITCH		427158-01	1	1	1	-					
	TRUSS HEAD SCREW	SS, 4 X 6	7C32-0406	2	2	2	-					
4	BUSHING		420470-07	1	1	1	1	1	1	1		
5	HINGE		3A0762-01	1	1	1	1	1	1	1		
6	THUMBSCREW		415949G04	2	2	2	2	2	2	2		
7	ACTUATOR		208795G01	1	1	1	1	1	1	1		
8	SHAFT		412337-03	1	1	1	1	1	1	1		
9	SNAP PIN		715S-0004	1	1	1	1	1	1	1		

HA

P. Accessories

DCM-750BAF, DCM-750BWF

H-0, J-0, J-1, J-2, K-0, K-1, L-0, L-1, M-0, M-1, N-0

Title: P. Accessories Model: DCM-750BAF, DCM-750BWF												
Index No.	Description	Material or Model Number	Part Number	Required Number								
				H-0 J-0	J-1 J-2	K-0 K-1	L-0 L-1	M-0 M-1	N-0			
1	INSTRUCTION MANUAL		91A2EA10B	1	1	1	1	1	1			
	PACKAGING (ONLY AVAILABLE FOR MODELS CURRENTLY IN PRODUCTION)	-	1A0190G04	1	1	1	1	1	1			
2	CARTON	-	2A0839-28	1	1	1	1	1	1			
3	CORNER POST	-	3A0782-15	4	4	4	4	4	4			
4	CORNER POST		3A0782-16	2	2	2	2	2	2			
5	PALLET	-	2A0853-10	1	1	1	1	1	1			
6	SIDE PROTECTOR	-	4A2304-01	4	4	4	4	4	4			
7	WOOD BLOCK – B	-	4A0004-02	4	4	4	4	4	4			