

NO. U2MC-1564

ISSUED: APR. 13, 1994

FINAL: DEC. 2, 2003



**HOSHIZAKI
SELF-CONTAINED FLAKER**

MODEL F-250BAE

PARTS LIST

D-1 MAY 1994
D-2 JUN. 1994
E-0 JAN. 1995
E-1 APR. 1995
F-0 DEC. 1995
G-0 DEC. 1996
H-0 DEC. 1997
H-1 FEB. 1998

FINAL

MATERIAL ABBREVIATIONS

PLASTIC

ABS	=	Acrylonitrile-butadien-styrene
AC	=	Polyacetal
EVA	=	Ethylene vinyl acetate
PA	=	Polyamide = Nylon
PC	=	Polycarbonate
PE	=	Polyethylene
PES	=	Polyester
PETP	=	Polyethylene terephthalate = Tetlon
PF	=	Phenol-formaldehyde
PP	=	Polypropyleneoride
PS	=	Polystyrene
PTFE	=	Polytetrafluoroethylene = Teflon
PUR	=	Polyurethane
PVC	=	Polyvinyl chloride

RUBBER

EPDM	=	EP rubber
NBR	=	Nitrile butadiene rubber
NR	=	Natural rubber
SI.R	=	Silicone rubber
SY.R	=	Synthetic rubber

STEEL

G.S	=	Galvanized steel
S.S	=	Stainless steel

AUXILIARY CODE

- Ex.1 K-0
 ├── Parts are the same as in the preceding year.
 └── "K" is the tenth in alphabetical order with "I" skipped.
 So, "K" indicates "2000".
- Ex.2 A-1
 ├── "A" is the first in alphabetical order.
 └── So, "A" indicates "2001".
- Ex.3 A-2
 └── Each time a part is changed in a year, this number advances.

(Note) – = Part deleted.
 X = Part deleted and replaced by "O" part.
 O = New part for "X" in the same auxiliary code.

FASTENER ABBREVIATION LIST

ST	Phillips Truss Head Machine Screw
SP	Phillips Pan Head Machine Screw
SF	Phillips Flat Head Machine Screw
SS	Phillips Pan Head Machine Screw with Split Lock Washer
SW	Phillips Pan Head Machine Screw with Split Lock Washer and Flat Washer
T1	Phillips Truss Head Tapping Screw (Correspond to Type A)
T2	Phillips Truss Head Tapping Screw (Correspond to Type B)
T3	Phillips Truss Head Tapping Screw (Correspond to Type C)
FT	Phillips Truss Head Tapping Screw (Special)
BH	Hexagon Head Bolt
BC	Socket Head Cap Screw
BS	Hexagon Bolt with Split Washer
BW	Hexagon Bolt with Split Washer and Flat Washer
BF	Hexagon Flange Bolt
BR	Cross-Recessed Hexagon Head Bolt
BRW	Cross-Recessed Hexagon Head Bolt with Split Lock Washer and Flat Washer
WL	Split Lock Washer
WT	External Tooth Washer
WF	Flat Washer
WS	Spring Washer
NH	Hexagon Nut
NF	Hexagon Flange Nut
NC	Hexagon Cap Nut
NS	Square Nut
NW	Wing Nut

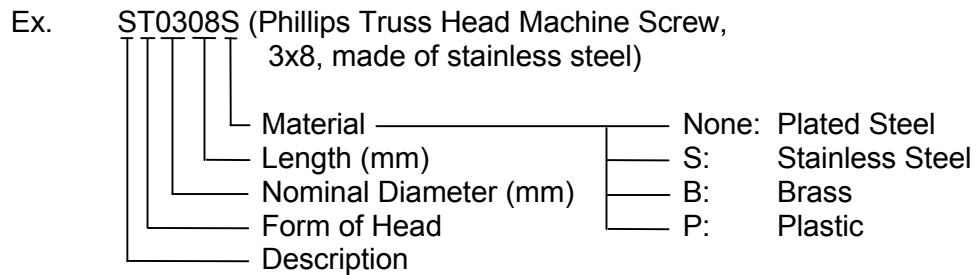

(Note) Second character is numerical except the list.

Ex. S1, S2, B3 etc.

And abbreviations and names are shown under the illustration.

HA
F-250BAE

A. ICE FLAKER ASSY

(H-0)(H-1)
(F-0)(G-0)
(E-0)(E-1)
(D-2)(D-1)

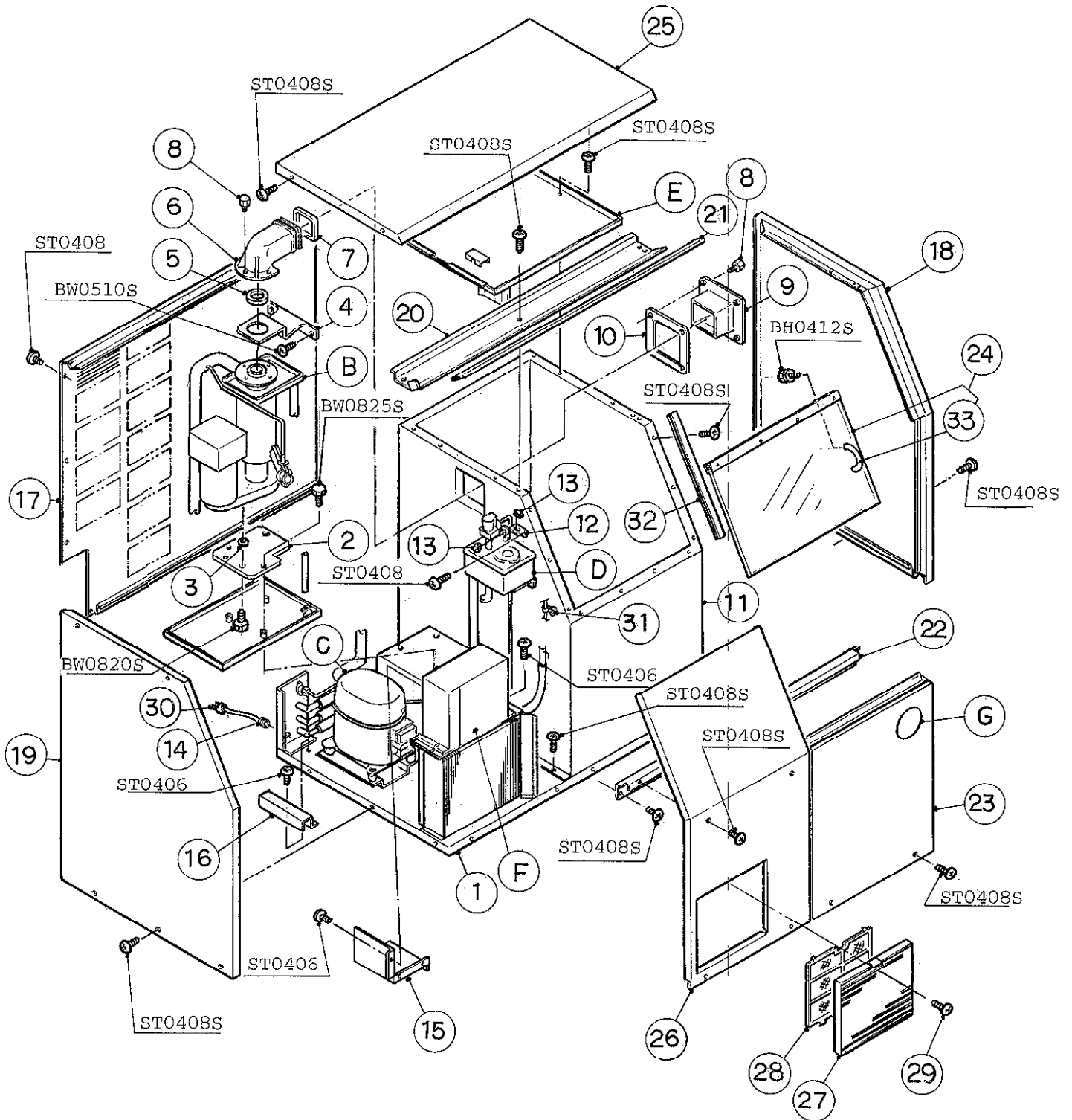

HA

MODEL: F-250BAE TITLE: A. ICE FLAKER ASSY							
INDEX NO.	DESCRIPTION	MATERIAL OR MODEL NUMBER	PART NUMBER	REQ'D NUMBER			
				D-1	D-2 E-0	E-1 F-0 G-0 H-0	H-1
B	EVAPORATOR ASSY	-	320291A03	1	x 1		
		-	320291A04			o 1	1
C	REFRIGERATION UNIT	-	107029A01	1	1	1	1
D	WATER CIRCUIT	-	103324A03	1	1	1	1
E	COVER ASSY - BIN TOP	-	317056A01	1	1	1	1
F	CONTROL BOX ASSY	-	221365A01	1	1	1	1
G	LABEL LOCATION	-	221367A01	1	x 1		
		-	221367A02			o 1	1
1	CHASSIS	G.S	103322G02	1	1	1	1
2	BRACKET - GEAR MOTOR	S.S	427226-01	1	1	1	1
3	WASHER	PVC	425206-01	3	3	3	3
4	BRACKET - EVAPORATOR	S.S	317055-01	1	1	1	1
5	PACKING - CYLINDER	EPDM	427151-01	1	1	1	1
6	SPOUT	PC	208791-01	1	1	1	1
7	PACKING (A) - SPOUT	EPDM	427152-01	1	1	1	1
8	THUMBSCREW	S.S, ABS	415949G03	7	7	7	7
9	SPOUT (B)	ABS	208792-01	1	1	1	1
10	PACKING (B) - SPOUT	EPDM	427153-01	1	1	1	1
11	BIN - FOAMED	-	208793G01	1	1	1	1
12	BRACKET - FLOAT SWITCH LEADS	G.S	427165-01	1	1	1	1
13	BUSHING	SR-30-1	420472-03	2	2	2	2
14	BUSHING	SR-7K-2	420472-02	1	1	1	1
15	BARRIER	G.S	317060-01	1	1	1	1
16	BARRIER - LEADS	G.S	427166-01	1	1	1	1
17	REAR PANEL	G.S	208797-01	1	1	x 1	
		G.S	228251G01			o 1	1
18	SIDE PANEL (RIGHT)	S.S	208798G01	1	1	1	
19	SIDE PANEL (LEFT)	S.S	208799G03	1	1	1	
20	FRAME	S.S	317061-03	1	1	1	
21	EDGING	CE-010-S	425931-04	1	1	1	
22	BRACKET - FRONT PANEL	S.S	317062-01	1	1	1	

HA

MODEL: F-250BAE TITLE: A. ICE FLAKER ASSY							
INDEX NO.	DESCRIPTION	MATERIAL OR MODEL NUMBER	PART NUMBER	REQ'D NUMBER			
				D-1	D-2 E-0	E-1 F-0 G-0 H-0	H-1
23	FRONT PANEL (RIGHT)	S.S	317063G04	1	1	1	1
24	SLIDING DOOR (B)	-	317066A03	1	1	1	1
25	TOP PANEL	S.S	208800G01	1	1	x 1	
		S.S	228415G01			o 1	1
26	FRONT PANEL (LEFT)	S.S	103326G03	1	1	1	
27	LOUVER (A)	PP	103344-01	1	1	x 1	
		PP	113344-08			o 1	1
28	AIR FILTER (A)	PP	208840G01	1	1	1	1
29	TAPPING SCREW (BLACK)	STEEL,4x8	433954-01	1	1	1	1
30	POWER SUPPLY CORD	KP-30B	421824-01	1	1	1	1
31	CLAMP	NAD-09	418074-05	1	1	x 1	
		NAD-09	418074-05			o 2	2
32	PACKING - BIN	EPDM	428186-01	1	1	1	1
33	HANDLE - DOOR	ABS	444301-02	1	1	1	1

HA
F-250BAE

B. EVAPORATOR ASSY

(H-0)(H-1)
(F-0)(G-0)
(E-0)(E-1)
(D-2)(D-1)

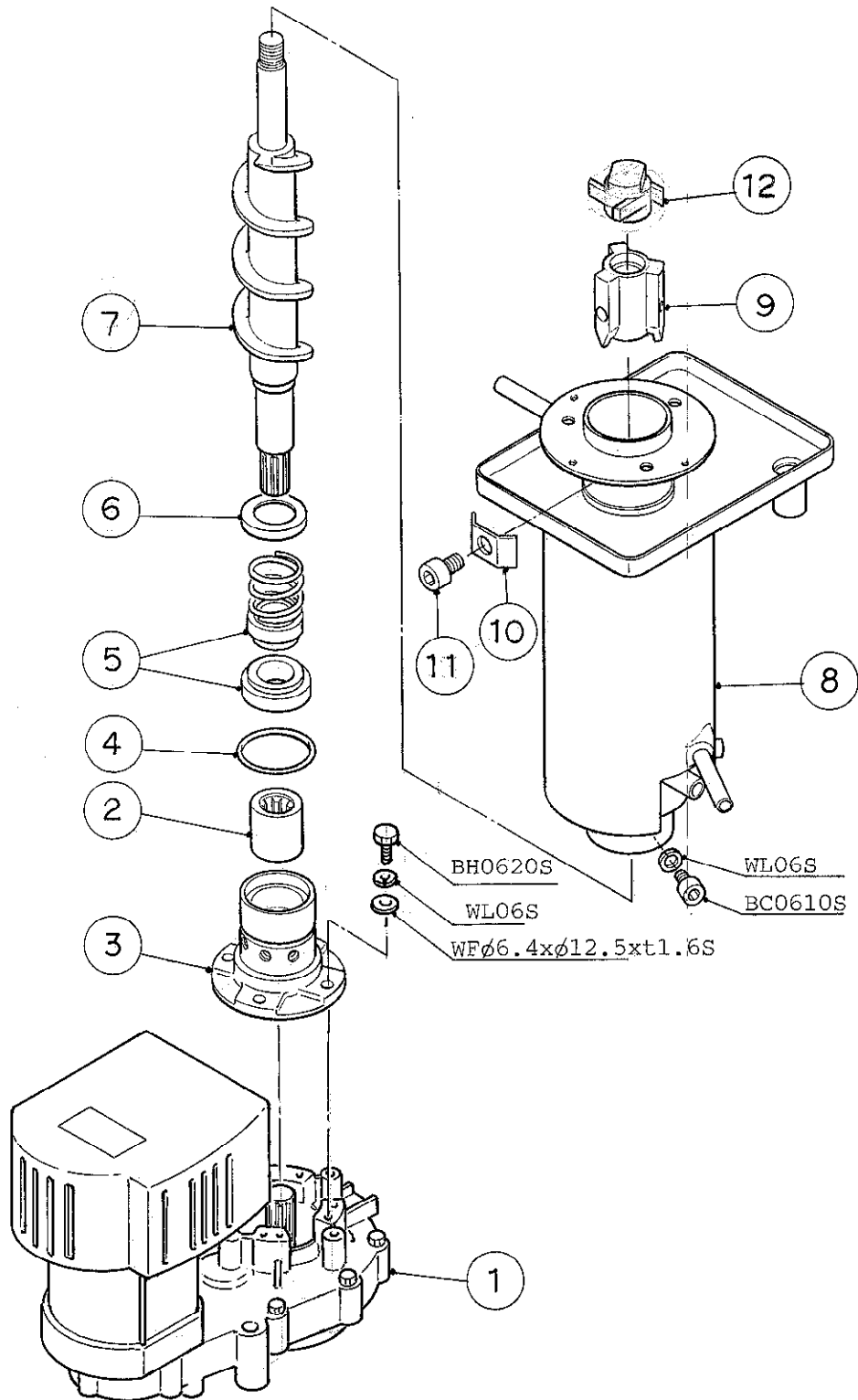

HA

MODEL: F-250BAE TITLE: B. EVAPORATOR ASSY							
INDEX NO.	DESCRIPTION	MATERIAL OR MODEL NUMBER	PART NUMBER	REQ'D NUMBER			
				D-1	D-2 E-0	E-1 F-0 G-0 H-0	H-1
1	GEAR MOTOR	TC1125, 120V 80W	2U0105-01	1	x 1		
		TC1148, 120V 80W	2U0146-01		x1		
		TC1185, 120V 80W	2U0147-01			o 1	1
2	COUPLING - SPLINE	S.S	418316-01	1	1	1	1
3	HOUSING	COPPER ALLOY	206013G03	1	1	1	1
4	"O" RING	G40	7616-G040	1	1	1	1
5	MECHANICAL SEAL	HK9A-MS	432491-01	1	1	1	1
6	RING (B)	S.S	432494-01	1	1	1	1
7	AUGER	S.S	328527G01	1	1	x1	
		S.S	341446G01				o 1
8	EVAPORATOR	-	317046G03	1	1	1	1
9	EXTRUDING HEAD / 45F	S.S	327140G01	1	1	1	1
10	WASHER	S.S	427138-01	3	3	3	3
11	SOCKET HEAD CAP SCREW	S.S,M8x14	429121-01	3	3	3	3
12	CUTTER	S.S	427137-01	1	1	1	1

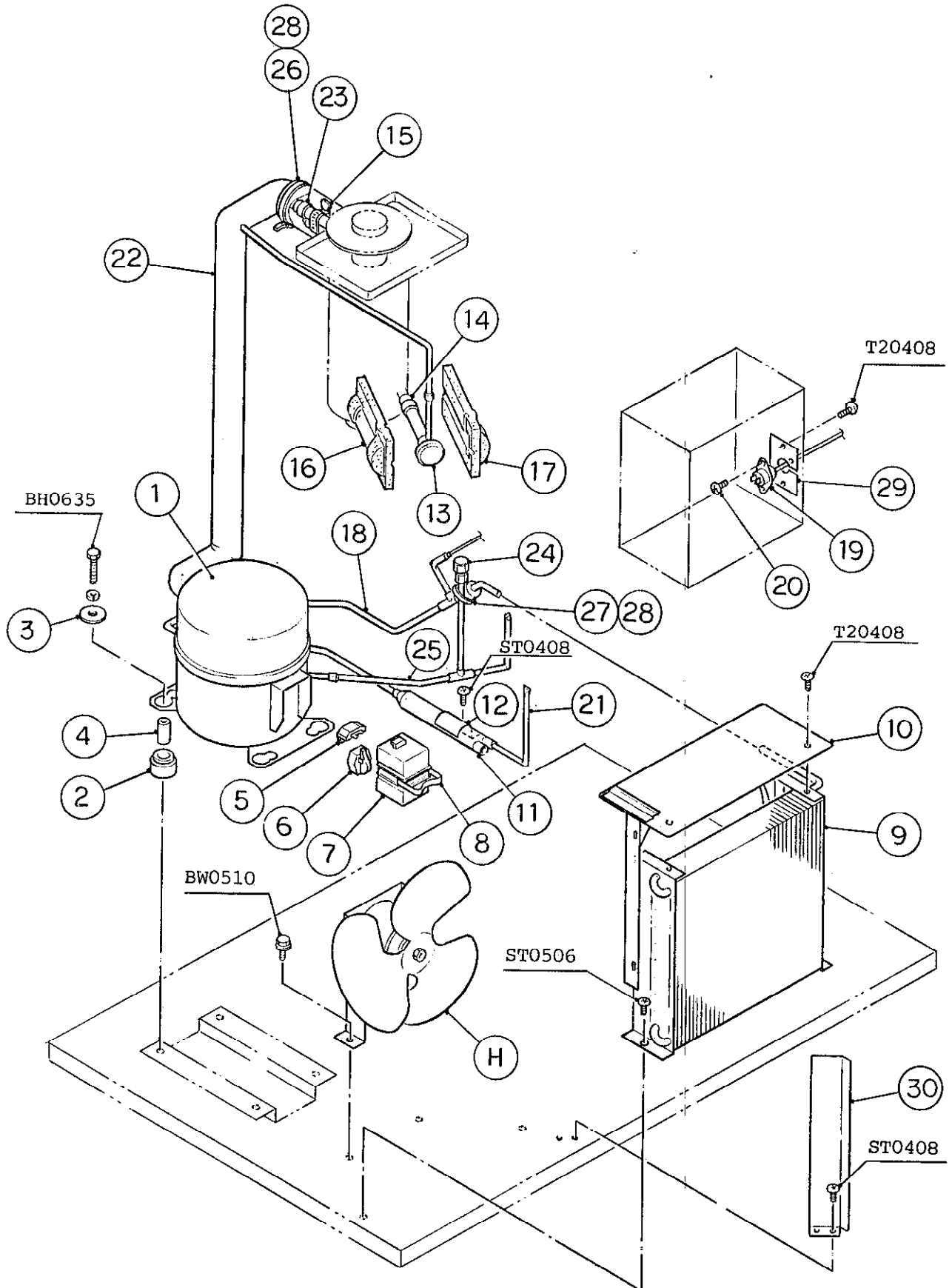

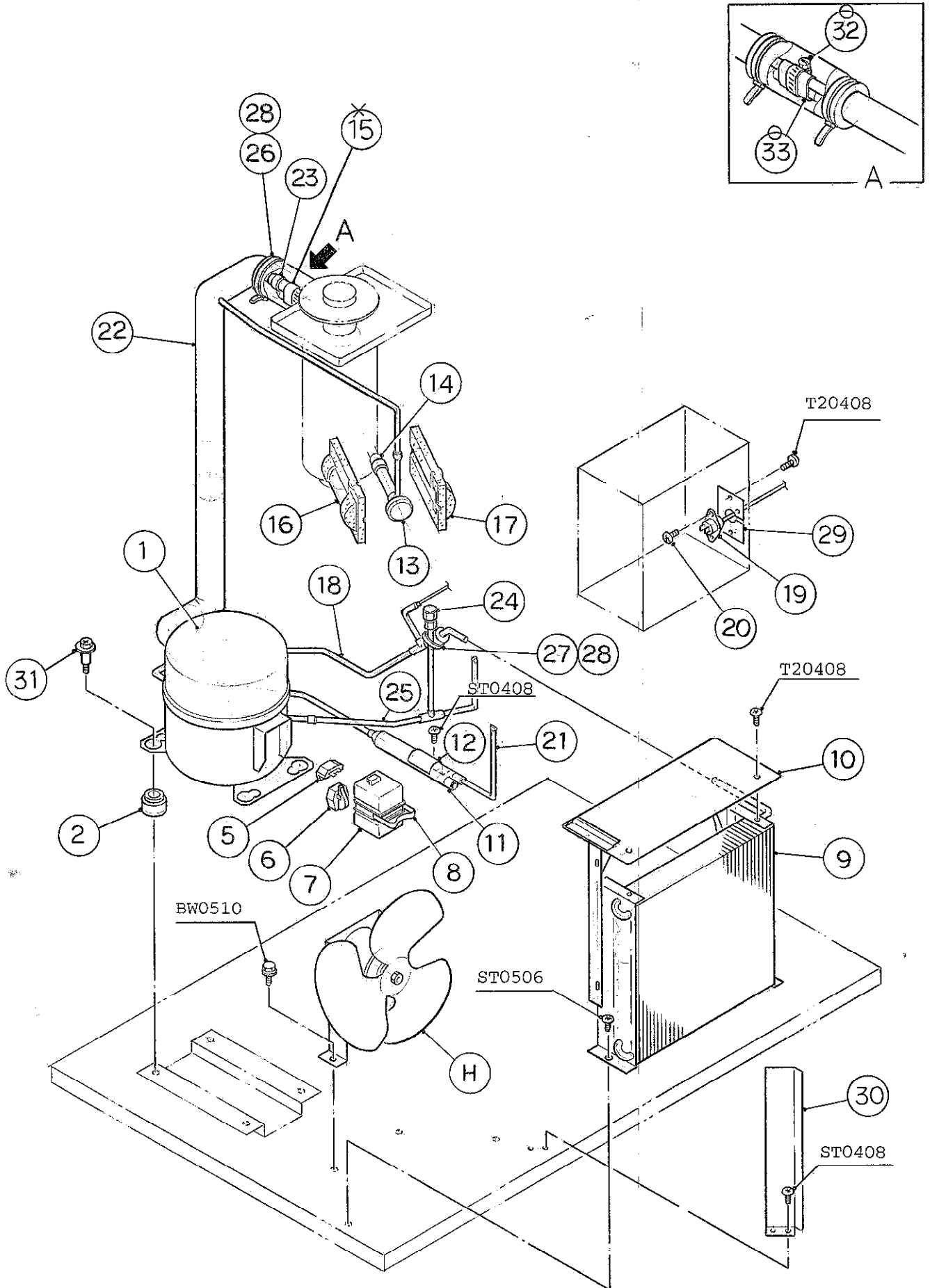

HA

MODEL: F-250BAE		TITLE: C. REFRIGERATION UNIT					
INDEX NO.	DESCRIPTION	MATERIAL OR MODEL NUMBER	PART NUMBER	REQ'D NUMBER			
				D-1	D-2 E-0	E-1 F-0 G-0 H-0	H-1
H	FAN MOTOR ASSY	(S-0375)	313392A01	1	1	1	1
1	COMPRESSOR	CE110Y-1ZU	446132-02	1	1	1	1
2	CUSHION	CR-Y2	443695-01	4	4	4	4
3	WASHER CUSHION	CW	432248-01	4	x 4		
4	BUSHING	BC	432249-01	4	x 4		
5	OVERLOAD	4TM777SFBZZ-62	447087-01	1	1	1	1
6	CONNECTOR	-	435923-01	1	1	1	1
7	TERMINAL COVER	-	434797-01	1	1	1	1
8	COVER BAND	S.S	434798-01	1	1	1	1
9	CONDENSER - AIR-COOLED	-	203942-01	1	1	1	1
10	SHROUD	G.S	208790G01	1	1	1	1
11	DRIER	KC-7860	444395-01	1	1	1	1
12	STRAP	G.S	419349-01	1	1	1	1
13	EXPANSION VALVE	HFE-5QHD-1	446808-01	1	1	1	1
14	REDUCER	COPPER	421904-01	1	1	1	1
15	CLAMP	D11-SS	435254-03	2	2	x 2	
16	COVER (C) - EXPANSION VALVE	PE FOAM	324313-03	1	1	1	1
17	COVER (D) - EXPANSION VALVE	PE FOAM	324313-04	1	1	1	1
18	COPPER TUBE (A) - HIGH SIDE	COPPER	333450G01	1	1	1	1
19	PRESSURE SWITCH	PS-7	3U0069-03	1	1	1	1
20	TAPPING SCREW	3x8	431415-01	2	2	2	2
21	PROCESS TUBE (B)	COPPER	428058-02	1	1	1	1
22	COPPER TUBE (B)	COPPER	221464G01	1	1	1	1
23	REDUCER	COPPER	421904-17	1	1	1	1
24	ACCESS VALVE	COPPER	446715-01	1	1	1	1
25	COPPER TUBE (C)	COPPER	447138G01	1	1	1	1
26	INSULATION TUBE	7762-2949, L=130	107029-33	1	1	1	1
27	INSULATION TUBE	7762-0717, L=30	107029-34	1	1	1	1
28	TIE	CV-150	7920-0003	6	6	6	6

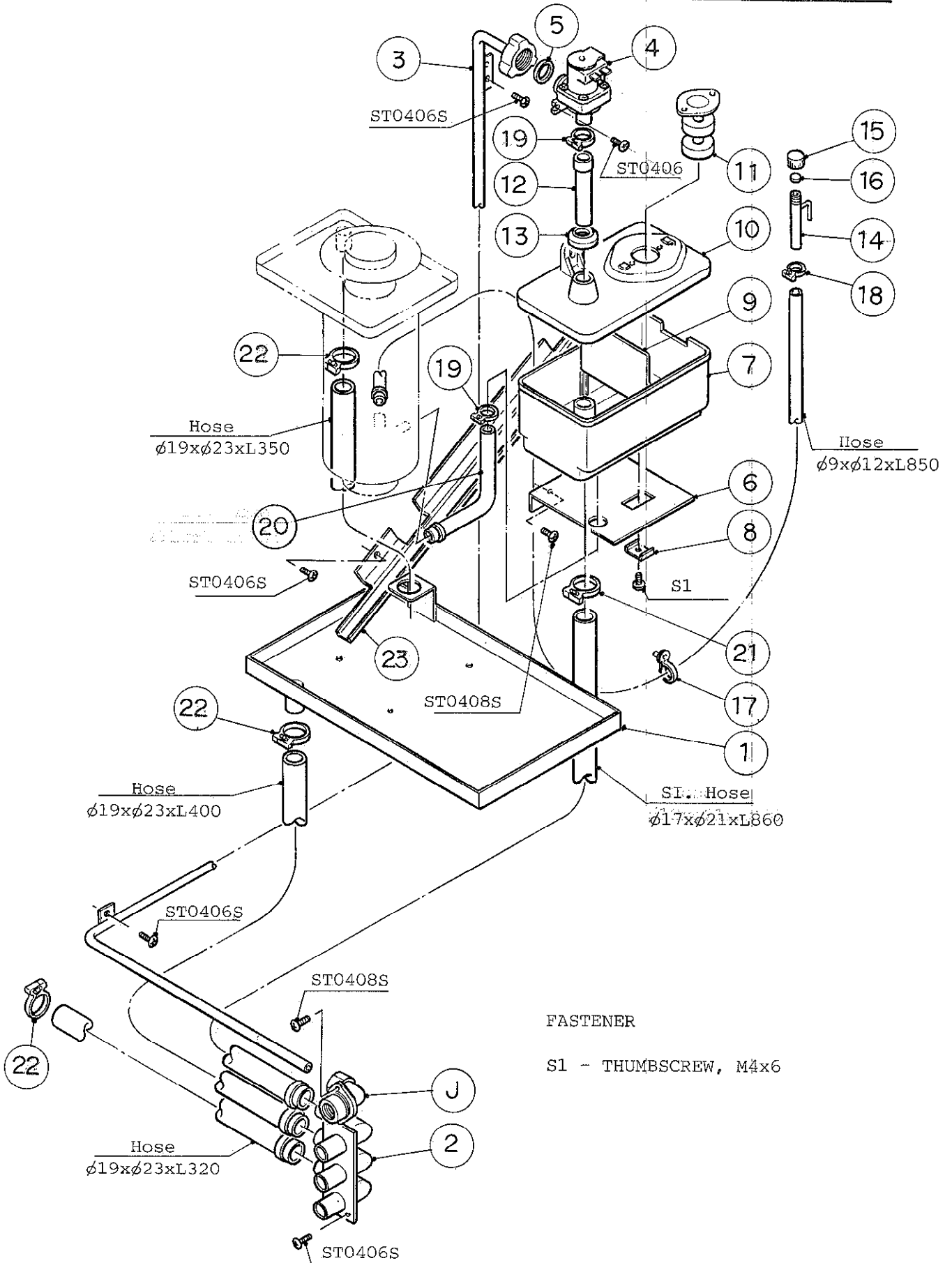

FASTENER

S1 - THUMBSCREW, M4x6

HA

MODEL: F-250BAE		TITLE: D. WATER CIRCUIT ASSY					
INDEX NO.	DESCRIPTION	MATERIAL OR MODEL NUMBER	PART NUMBER	REQ'D NUMBER			
				D-1	D-2 E-0	E-1 F-0 G-0 H-0	H-1
J	FITTING (M) ASSY	(S-0333)	310980A01	1	1	1	1
1	DRIP PIN	S.S	317053G01	1	1	1	1
2	PIPE - DRAIN	S.S	427144G02	1	1	1	1
3	PIPE - WATER SUPPLY	S.S	317054G03	1	1	1	1
4	WATER VALVE	J246-086	3U0065-01	1	1	1	1
5	PACKING	NBR	413854-03	1	1	1	1
6	BRACKET - RESERVOIR	G.S	428697-01	1	1	1	1
7	RESERVOIR	ABS	207527-01	1	1	1	1
8	COLLAR	S.S	423416-01	1	1	1	1
9	SEPARATOR - RESERVOIR	ABS	423538-01	1	1	1	1
10	COVER - RESERVOIR	ABS	103070-01	1	1	1	1
11	FLOAT SWITCH	TW-1221-101	435490-01	1	1	1	1
12	HOSE - WATER SUPPLY	EVA	425289-04	1	1	1	1
13	COVER - RESERVOIR INLET	SI. R	415094-01	1	1	1	1
14	PIPE - DRAIN	S.S	425292G01	1	1	1	1
15	CAP - DRAIN	BRASS	425293-01	1	1	1	1
16	PACKING - DRAIN	SY.R	425294-01	1	1	1	1
17	CLAMP	NAD-09	418074-05	1	1	1	1
18	CLAMP	MH-30N	421642-04	2	2	2	2
19	CLAMP	SK-17	435934-05	3	3	3	3
20	HOSE	EPDM	437256-06	1	1	1	1
21	CLAMP	MH-50N	421642-08	1	1	1	1
22	CLAMP	MH-56N	421642-09	6	6	6	6
23	GUTTER	S.S	427150-01	1	1	1	1

HA
F-250BAE

E. COVER ASSY - BIN TOP

(H-0)(H-1)
(F-0)(G-0)
(E-0)(E-1)
(D-2)(D-1)

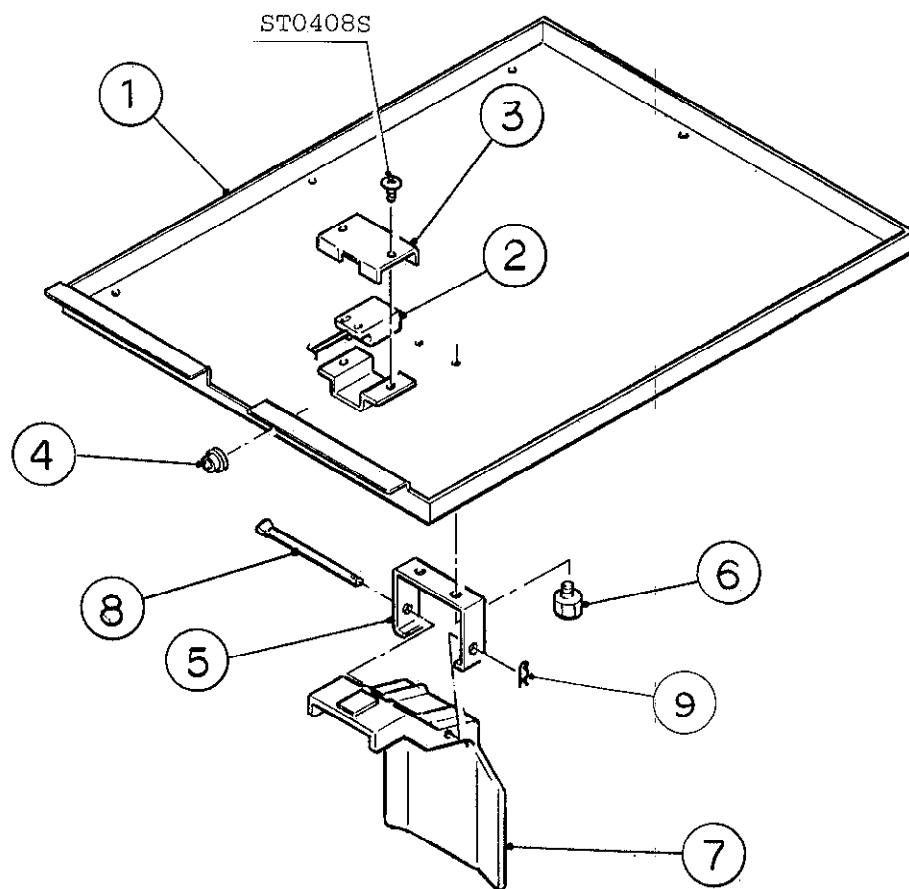

HA

MODEL: F-250BAE TITLE: E. COVER ASSY - BIN TOP							
INDEX NO.	DESCRIPTION	MATERIAL OR MODEL NUMBER	PART NUMBER	REQ'D NUMBER			
				D-1	D-2 E-0	E-1 F-0 G-0 H-0	H-1
1	COVER - BIN TOP	S.S	317057G01	1	1	1	1
2	PROXIMITY SWITCH	RS-601	427223-01	1	1	1	1
3	BRACKET - PROXIMITY SWITCH	S.S	427158-01	1	1	1	1
4	BUSHING	SB-437-5	420470-07	1	1	1	1
5	BRACKET - ACTIVATOR	S.S	317058-01	1	1	1	1
6	THUMBSCREW	S.S, ABS	415949G04	2	2	2	2
7	ACTIVATOR - SWITCH	ABS	208795G01	1	1	1	1
8	SHAFT	S.S	412337-03	1	1	1	1
9	SNAP PIN	S.S, SSP-4	715S-0004	1	1	1	1

HA
F-250BAE

F. CONTROL BOX ASSY

(H-0)(H-1)
(F-0)(G-0)
(E-0)(E-1)
(D-2)(D-1)

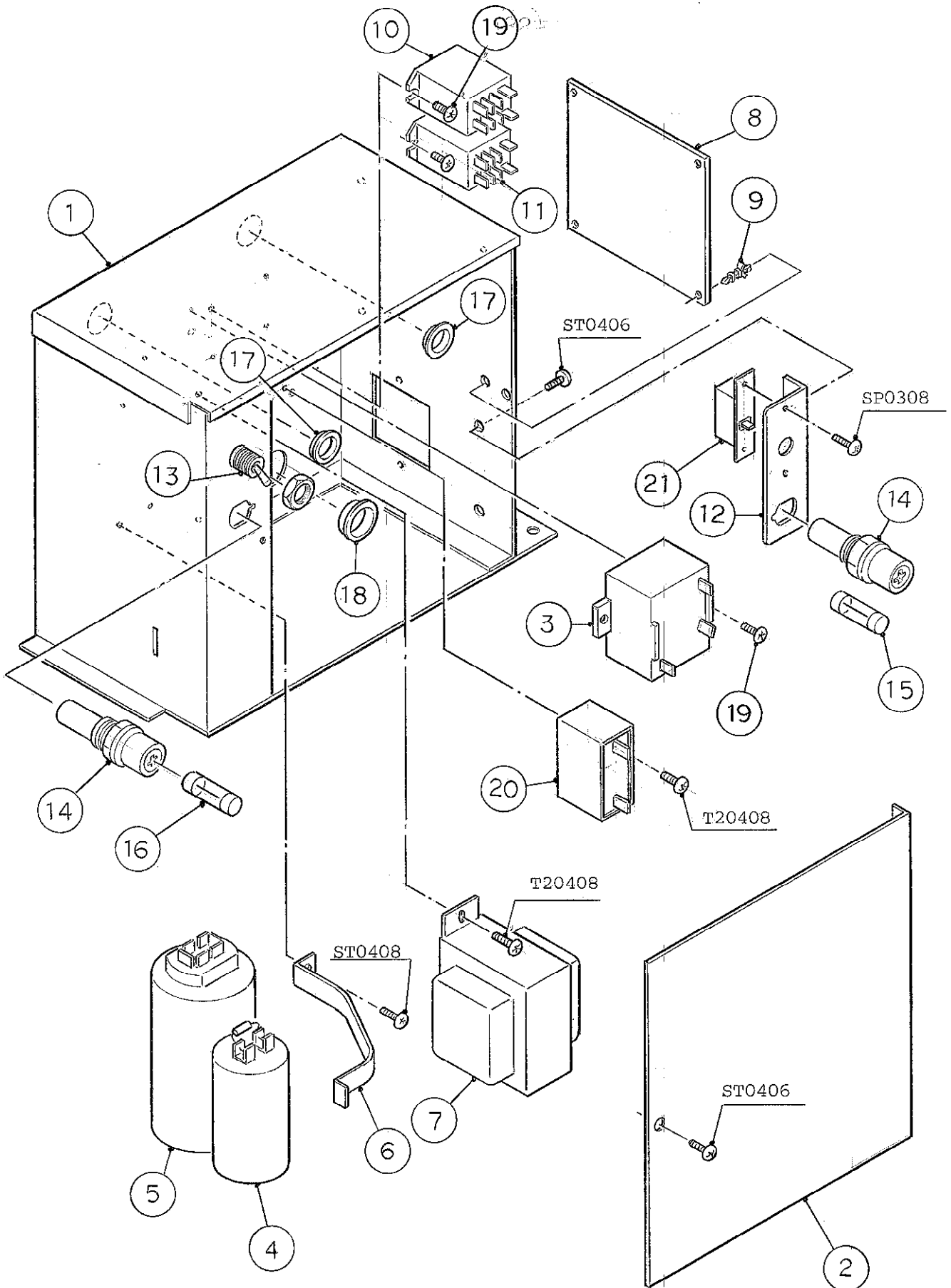

HA

MODEL: F-250BAE TITLE: F. CONTROL BOX ASSY							
INDEX NO.	DESCRIPTION	MATERIAL OR MODEL NUMBER	PART NUMBER	REQ'D NUMBER			
				D-1	D-2 E-0	E-1 F-0 G-0 H-0	H-1
1	CONTROL BOX	G.S	317059G03	1	1	1	1
2	COVER - CONTROL BOX	G.S	427162-02	1	1	1	1
3	STARTER	AMVL-170TA	443047-01	1	1	1	1
4	START CAPACITOR	150uF, 180VAC	446803-01	1	1	1	1
5	RUN CAPACITOR	20uF, 220V	447088-01	1	1	1	1
6	STRAP	G.S	434174-06	1	1	1	1
7	TRANSFORMER	TR5267, 120/24V 1A	2U0042-01	1	1	1	1
8	TIMER BOARD	H2AA144C02	437305-02	1	1	1	1
9	BOARD SUPPORT	KGLS-6S	414929-01	4	4	4	4
10	RELAY	LY1F, AC120V	418271-03	1	1	1	1
11	RELAY	LY2ZF, AC24V	406132-06	1	1	1	1
12	BRACKET	G.S	435309-01	1	1	1	1
13	TOGGLE SWITCH	WD2119	434870-01	1	1	1	1
14	FUSE HOLDER	FH032, 250V 10A	424288-01	2	2	x 2	
		F-130, 250V 10A	446963-01			o 2	2
15	FUSE	FGAO2, 250V 1A	420468-03	1	1	1	1
16	FUSE	10A	420468-04	1	1	1	1
17	BUSHING	SB-625-8	420470-01	2	2	2	2
18	BUSHING	SB-750-10	420470-05	1	1	1	1
19	TAPPING SCREW	3x8	431415-01	4	4	4	4
20	CAPACITOR	280VAC, 10uF	416921-05	1	1	1	1
21	OVERLOAD - GEAR MOTOR	NW-3P-2	427253-01	1	1	1	1

HA
F-250BAE

G. LABEL LOCATION

(H-0)(H-1)
(F-0)(G-0)
(E-0)(E-1)
(D-2)(D-1)

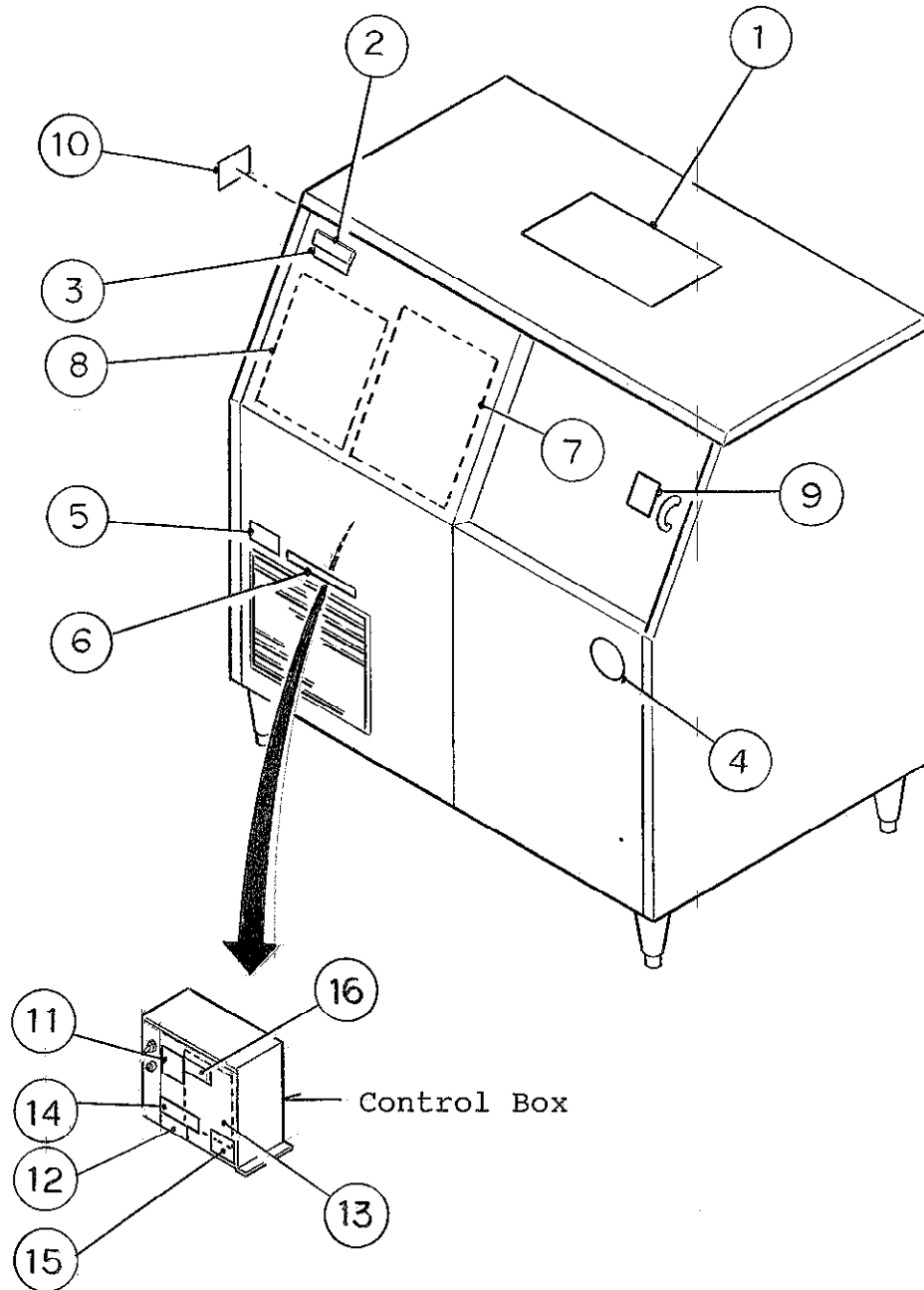

HA

MODEL: F-250BAE TITLE: G. LABEL LOCATION							
INDEX NO.	DESCRIPTION	MATERIAL OR MODEL NUMBER	PART NUMBER	REQ'D NUMBER			
				D-1	D-2 E-0	E-1 F-0 G-0 H-0	H-1
1	INSTRUCTION SHEET - INST. OPE.	PAPER	317039-01	1	1	1	1
2	EMBLEM (L) - HOSHIZAKI	ABS	418634G01	1	1	1	1
3	MODEL NUMBER LABEL	PETP FILM	435985-41	1	1	1	1
4	LABEL - PENGUIN (L)	PETP FILM	410994-02	1	1	1	1
5	LABEL - WARNING	PVC FILM	425323-01	1	1	1	1
6	LABEL - AIR FILTER	PETP FILM	426177-01	1	1	1	1
7	LABEL - OPERATION	PVC FILM	317037-01	1	1	1	1
8	LABEL - CLEANING	PVC FILM	317036-01	1	1	1	1
9	LABEL - SLIDING DOOR	PETP FILM	427123-01	1	1	1	1
10	NAMEPLATE	PES FILM	447090-01	1	1	1	1
11	LABEL - SWITCH, FUSE	PETP FILM	427179-01	1	1	1	1
12	WARNING LABEL - DANGER	PVC FILM	425322-01	1	1	1	x 1
	CAUTION LABEL - G	PVC FILM	439147-01				o 1
13	WIRING LABEL	PVC FILM	333374-01	1	x 1		
		PVC FILM	335853-01			o 1	1
14	RATING LABEL	PES FILM	447091-01	1	1	1	1
15	LABEL - RESET	PETP FILM	435319-01	1	1	1	1
16	LABEL - R134a	PES FILM	444463-01	1	1	1	1

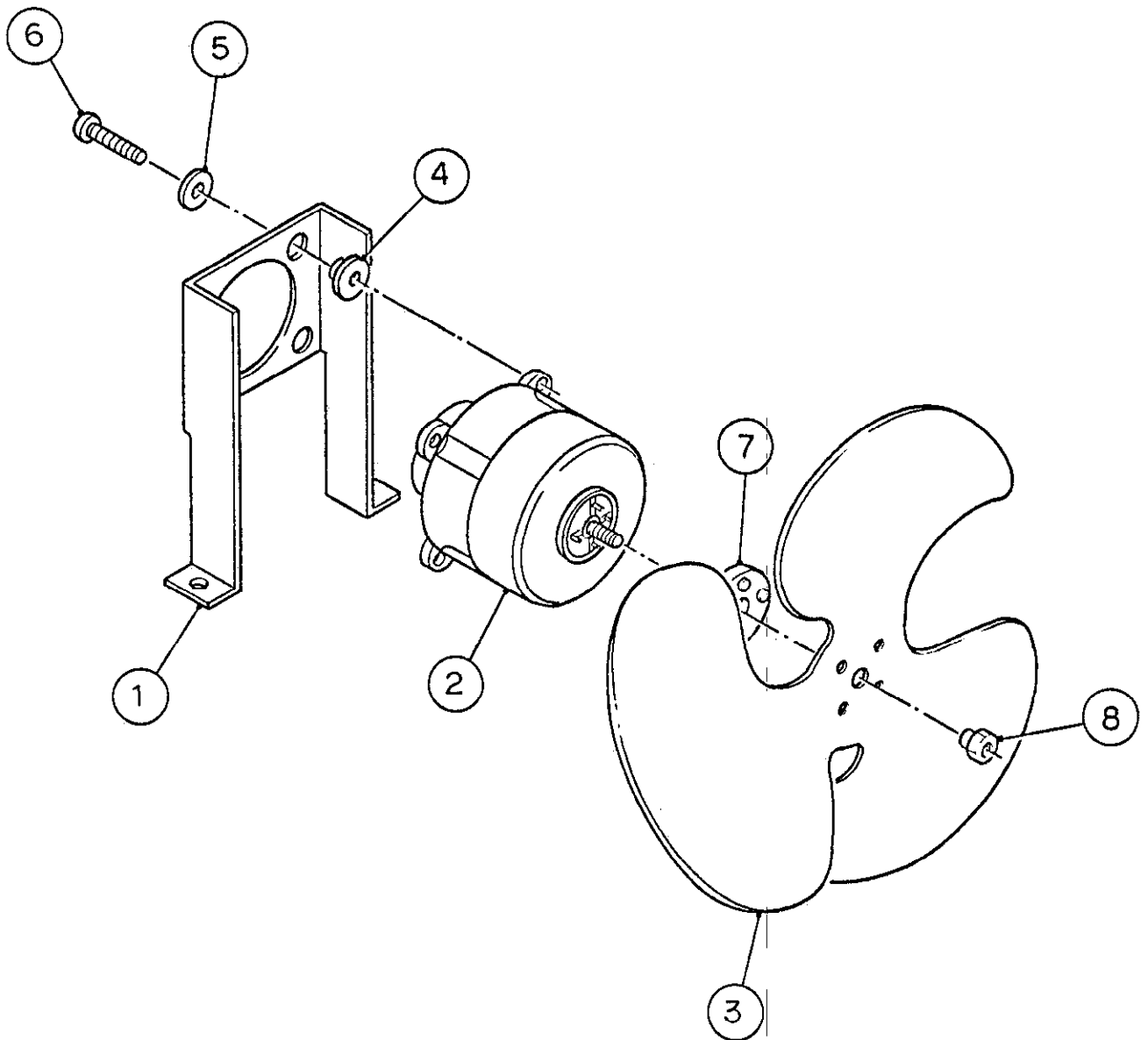

HA

MODEL: F-250BAE TITLE: H. FAN MOTOR ASSY							
INDEX NO.	DESCRIPTION	MATERIAL OR MODEL NUMBER	PART NUMBER	REQ'D NUMBER			
				D-1	D-2 E-0	E-1 F-0 G-0 H-0	H-1
1	BRACKET (B) - FAN MOTOR	G.S	307282-02	1	1	1	1
2	FAN MOTOR	EK-TZ2	2U0005-01	1	1	1	1
3	FAN BLADE	Ø230, ALUMINIUM	414392-01	1	1	1	1
4	GROMMET (A)	NR	414390F01	3	3	3	3
5	WASHER - GROMMET	STEEL	414390F03	3	3	3	3
6	SCREW	STEEL	414390F05	3	3	3	3
7	VIBRATION PAD	NR	414390F06	1	1	1	1
8	NUT	STEEL	414390F07	1	1	1	1

(S-0333)

HA
F-250BAE

J. FITTING (N) ASSY

(H-0) (H-1)
(F-0) (G-0)
(E-0) (E-1)
(D-2) (D-1)

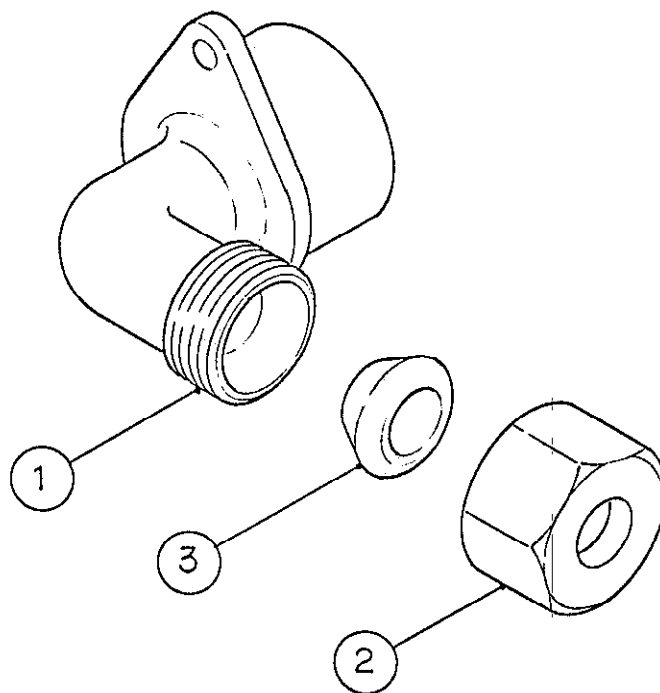

HA

MODEL: F-250BAE TITLE: J. FITTING (M) ASSY							
INDEX NO.	DESCRIPTION	MATERIAL OR MODEL NUMBER	PART NUMBER	REQ'D NUMBER			
				D-1	D-2 E-0	E-1 F-0 G-0 H-0	H-1
1	FITTING (M)	BRASS	310980-01	1	1	1	1
2	NUT (B) - FITTING	BRASS	415713-02	1	1	1	1
3	PACKING (C)	NBR	415715-02	1	1	1	1

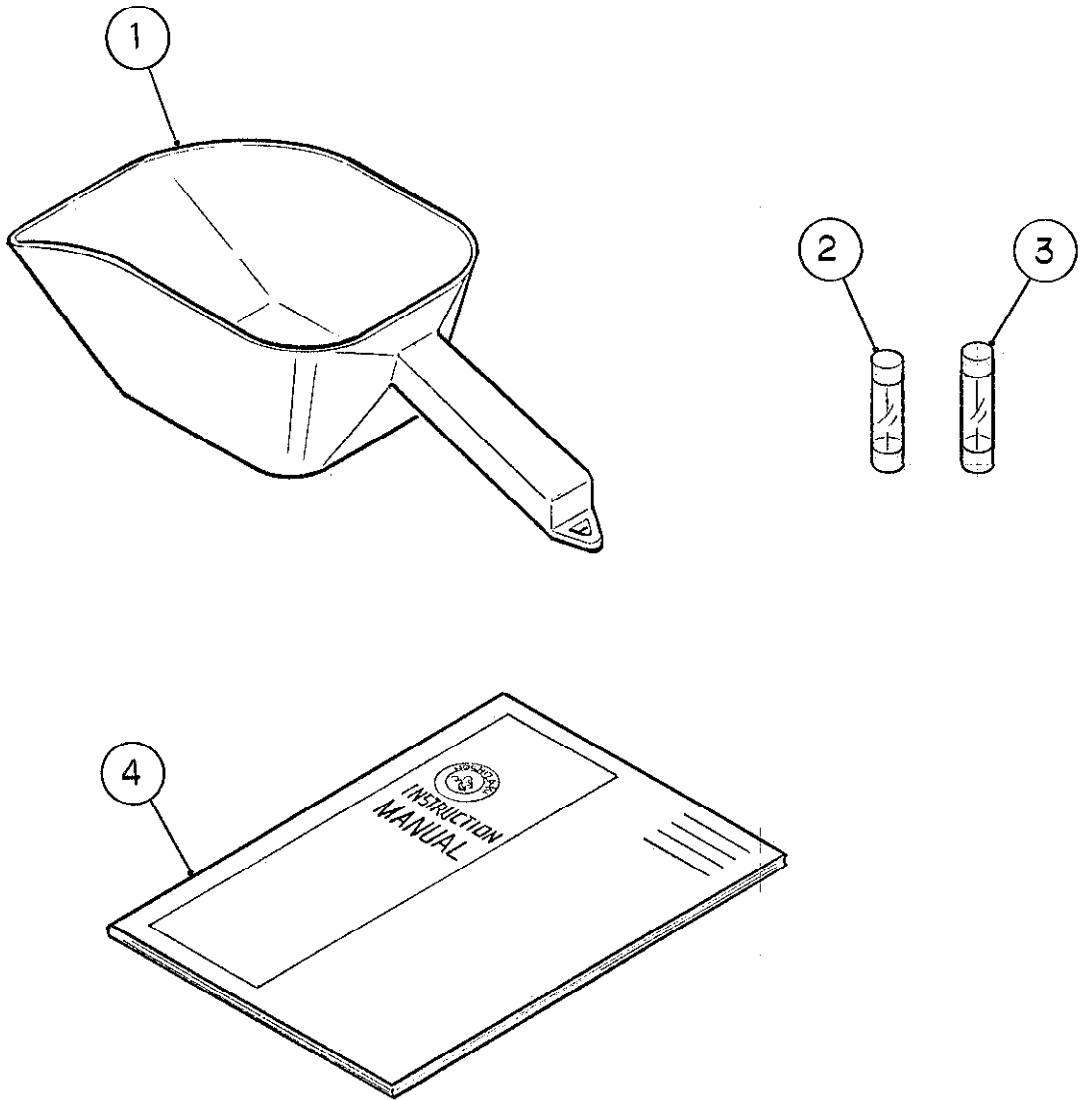

HA

MODEL: F-250BAE TITLE: K. ACCESSORIES							
INDEX NO.	DESCRIPTION	MATERIAL OR MODEL NUMBER	PART NUMBER	REQ'D NUMBER			
				D-1	D-2 E-0	E-1 F-0 G-0 H-0	H-1
1	SCOOP	PE	208185-01	1	1	1	1
2	FUSE	FGAO2 , 250V 1A	420468-03	1	1	1	1
3	FUSE	10A	420468-04	1	1	1	1
4	INSTRUCTION MANUAL	PAPER	91U2MC10A	1	1	1	1