NO. 71150

ISSUED: SEPT. 8, 1999

REVISED: AUG. 27, 2002



**HOSHIZAKI
MODULAR FLAKER**

**MODEL
F-450MAF(-C)**

(FINAL) PARTS LIST

F-450MAF	H-0	JUL. 1998
	J-0	FEB. 1999
	K-0	DEC. 1999
	L-0	DEC. 2000

F-450MAF-C	H-0	FEB. 1998
	J-0	JAN. 1999
	K-0	DEC. 1999
	L-0	DEC. 2000

MATERIAL ABBREVIATIONS

ALUMINUM

AL = Aluminum

COPPER

CU = Copper

PLASTIC

ABS = Acrylonitrile -butadiene - styrene
AC = Polyacetal
EVA = Ethylene vinyl acetate
PA = Polyamide = Nylon
PC = Polycarbonate
PE = Polyethylene
PES = Polyester
PETP = Polyethylene terephthalate = Tetlon
PP = Polypropylene
PS = Polystyrene
PIFE = Polytetrafluoroethylene = Teflon
PUR = Polyurethane
PVC = Polyvinyl chloride

RUBBER

VN = Vinyl Nitrile
EPDM = EP rubber
NBR = Nitrile butadiene rubber
NR = Natural rubber
NP = Neoprene
SI.R = Silicone rubber
SY.R = Synthetic rubber
EPH = Epichlorohydrin

STEEL

GS = Galvanized steel
SS = Stainless steel
PS = Plated steel
PAS = Primed steel

AUXILIARY CODE

Ex.1

K-0
├── Parts are the same as in the preceding
│ year.
└── "K" is the tenth in alphabetical order with "I"
 skipped. So, "K" indicates "2000".

(Note) - = Part deleted.

x = Part deleted and replaced
by "o" part.

o = New part for "x"
in the same auxiliary code.

Ex.2

L-0
├── "L" is the next in alphabetical
│ order. So, "L" indicates "2001".
└──

Ex.3

L-1
├── Each time a part is changed non-interchangeably,
│ in a year, this number advances.
└──

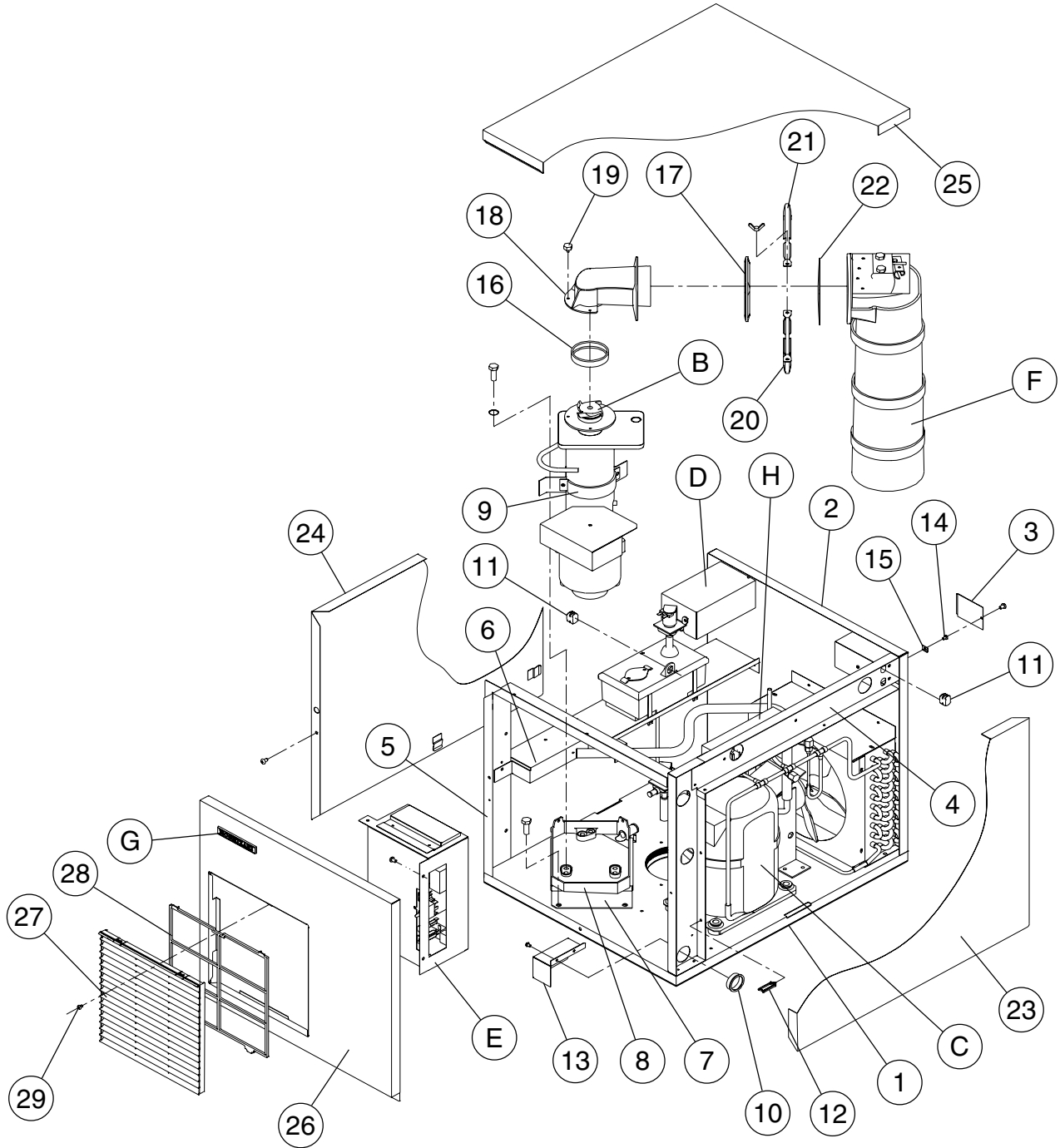

MODEL: F-450MAF TITLE: A. ICE FLAKER ASSEMBLY											
INDEX NO.	DESCRIPTION	MATERIAL OR MODEL NUMBER	PART NUMBER	REQUIRED NUMBER							
				H-0	K-0	L-0					
B	ICE MAKING UNIT	-	3A0841A01	1	1	1					
C	REFRIGERATION UNIT	-	2A0962A01	1	1	1					
D	WATER CIRCUIT	-	2A0942A01	1	1	1					
E	CONTROL BOX ASSEMBLY	-	2A0953A01	1	1	1					
F	CHUTE ASSEMBLY	HS-2007	2A0941A03	1	-						
		HS-2007	2A1705A03		1	1					
G	LABEL LOCATION	-	3A0876A01	1	1	1					

MODEL: F-450MAF-C TITLE: A. ICE FLAKER ASSEMBLY											
INDEX NO.	DESCRIPTION	MATERIAL OR MODEL NUMBER	PART NUMBER	REQUIRED NUMBER							
				H-0 J-0	K-0	L-0					
B	ICE MAKING UNIT	-	3A0841A02	1	1	1					
C	REFRIGERATION UNIT	-	2A0962A01	1	1	1					
D	WATER CIRCUIT	-	2A0942A01	1	1	1					
E	CONTROL BOX ASSEMBLY	-	2A0953A01	1	1	1					
F	CHUTE ASSEMBLY	-	3A0874A01	1	1	1					
G	LABEL LOCATION	-	3A0876A02	1	1	1					
H	POWER SUPPLY ASSEMBLY	-	4A1315A01	1	1	1					

MODEL: F-450MAF/-C TITLE: A. ICE FLAKER ASSEMBLY									
INDEX NO.	DESCRIPTION	MATERIAL OR MODEL NUMBER	PART NUMBER	REQUIRED NUMBER					
				H-0 J-0	K-0	L-0			
1	CHASSIS	GS	2A1178G01	1	1	1			
2	REAR PANEL	GS	2A0916G01	1	1	1			
	TRUSS HEAD SCREW	SS, 4 x 8	7C31-0408	2	2	2			
	T2 SCREW	SS, 4 x 8	7P32-0408	2	2	2			
3	JUNCTION BOX COVER	GS	433410-01	1	1	1			
	T2 SCREW	4 x 8	7P31-0408	1	1	1			
4	SIDE FRAME (R)	GS	2A0917G01	1	1	1			
	TRUSS HEAD SCREW	4 x 8	7C31-0408	4	4	4			
5	FRONT FRAME	GS	2A0918G01	1	1	1			
	TRUSS HEAD SCREW	4 x 8	7C31-0408	4	4	4			
6	BRACKET - RESERVOIR	GS	2A0919G01	1	1	1			
	T2 SCREW	4 x 8	7P31-0408	4	4	4			
7	BRACKET - GEAR MOTOR	GS	3A0396G01	1	1	1			
	HEX BOLT	SS, 8 x 12	7B02-0812	2	2	2			
8	DRAIN PAN	ABS	323765G02	1	1	1			
	SOCKET HEX HEAD BOLT	SS, 8 x 95	7S12-0895	3	3	3			
	SPRING WASHER	SS, 8	7L22-0800	3	3	3			
9	STRAP	GS	4A1262-01	1	1	1			
	T3 SCREW	5 x 12	7G31-0512	2	2	2			
10	BUSHING	SB-1500-21	420470-06	4	4	4			
11	BUSHING	SB-1500-21	420472-03	2	2	2			
12	WIRE SADDLE	LWS-4NS	4A0338-04	9	9	9			
13	BARRIER	GS	4A0688-01	1	1	1			
	FT SCREW	SS, 4 x 8	7F32-0408	2	2	2			
14	SCREW - GROUNDING	BRASS	433304-02	1	1	1			
15	SQUARE WASHER	BRASS	433537-02	1	1	1			
16	PACKING	EPDM	427151-01	1	1	1			
17	PACKING – SPOUT	EPDM	321037-01	1	1	1			
18	SPOUT	PC	2A0915-01	1	1	1			
19	THUMBSCREW	SS, ABS	415949G04	3	3	3			

MODEL: F-450MAF/-C TITLE: A. ICE FLAKER ASSEMBLY											
INDEX NO.	DESCRIPTION	MATERIAL OR MODEL NUMBER	PART NUMBER	REQUIRED NUMBER							
				H-0 J-0	K-0	L-0					
20	STRAP	SS	321038G02	1	1	1					
21	STRAP	SS	328703-02	1	1	1					
	WING NUT	SS, 6	7E12-0600	2	2	2					
22	BRACKET - CHUTE	SS	4A1712-01	1	1	1					
23	SIDE PANEL (R)	SS	2A0912G01	1	1	1					
	TRUSS HEAD SCREW	SS, 4 x 8	7C32-0408	1	1	1					
24	SIDE PANEL (L)	SS	2A0911G01	1	1	1					
	TRUSS HEAD SCREW	SS, 4 x 8	7C32-0408	1	1	1					
25	TOP PANEL	SS	2A1051-02	1	1	1					
26	FRONT PANEL	SS	2A0913-01	1	1	1					
	TRUSS HEAD SCREW	SS, 4 x 10	7C32-0410	1	1	1					
27	LOUVER (B)	PP	103121-03	1	1	1					
28	AIR FILTER (B)	-	208283G03	1	1	1					
29	TAPPING SCREW - BLACK	STEEL, 4X8	433954-01	1	1	1					
30	CABLE TIE	CV - 150	7920-0003	1	1	1					

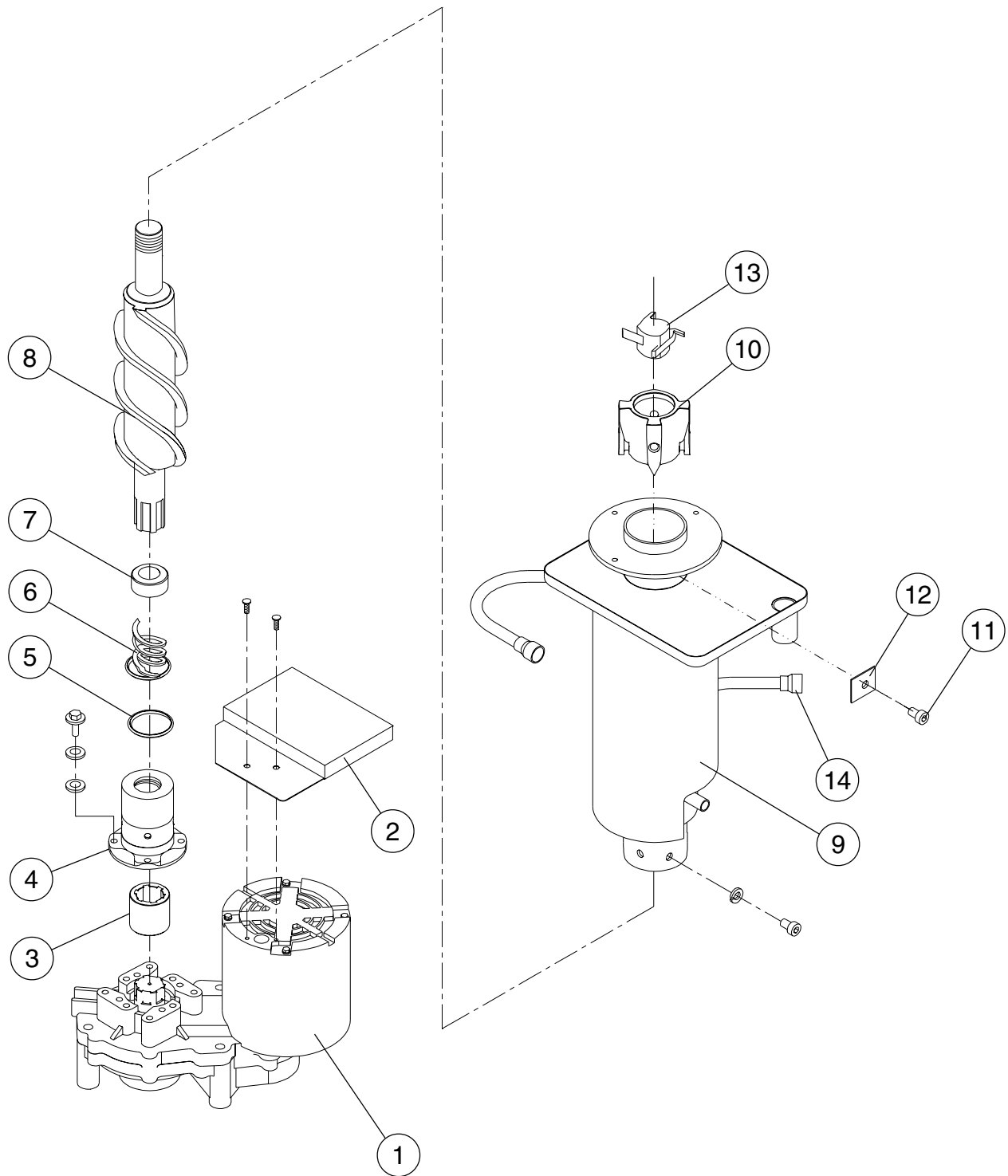

MODEL: F-450MAF TITLE: B. ICE MAKING UNIT										
INDEX NO.	DESCRIPTION	MATERIAL OR MODEL NUMBER	PART NUMBER	REQUIRED NUMBER						
				H-0 J-0	K-0	L-0				
1	GEAR MOTOR	V06695AEAA	4A0897-02	1	1	x1				
		-	4A2193-01			o1				
2	BARRIER - GEAR MOTOR	GS	3A1037-01	1	1	1				
	FT SCREW	SS, 4 x 8	7F32-0408	2	2	2				
3	COUPLING – SPLINE	SS	418316-01	1	1	1				
4	HOUSING	BRASS	206013G03	1	1	1				
	HEX BOLT	GOLD STAINLESS, 6 x 20	7B02-0620	4	4	-				
	BOLT	-	458660-01			4				
	PLAIN WASHER	SS, Ø6.4 x Ø12.5 x t 1.6	7W22-0616	4	4	-				
	SPRING WASHER	SS, 6	7L22-0600	4	4	-				
5	“O” RING	G40	7616-G040	1	1	1				
6	MECHANICAL SEAL	HK9A-MS φ22	432491-01	1	1	1				
7	RING (B)	NTKU-4	432494-01	1	1	1				
8	AUGER	SS	341448G01	1	1	1				
9	EVAPORATOR	-	340076G01	1	x1					
		-	2A1699G01		o1	1				
	SOCKET HEAD CAP SCREW	SS, 6 x 10	7S12-0610	4	4	4				
	SPLIT LOCK WASHER	SS, 6	7L22-0800	4	4	4				
10	EXTRUDING HEAD – 45F	SS	340077G01	1	1	1				
11	SOCKET HEAD CAP SCREW	SS, 8 x 14	429121-01	3	3	3				
12	WASHER	SS	453791-01	3	3	3				
13	CUTTER	SS	453790-01	1	1	1				
14	REDUCER	COPPER	420915-06	1	1	1				

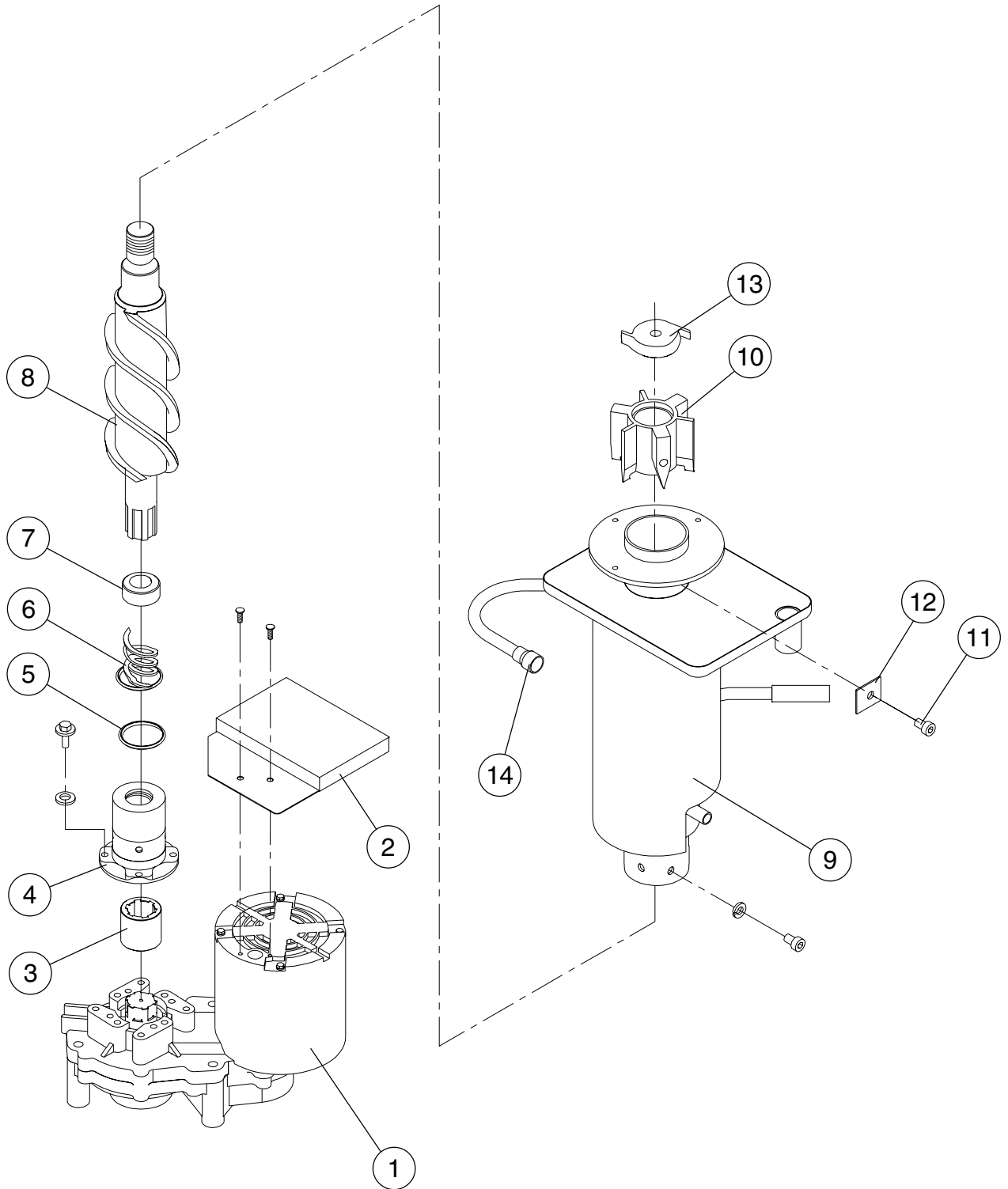

MODEL: F-450MAF-C TITLE: B. ICE MAKING UNIT										
INDEX NO.	DESCRIPTION	MATERIAL OR MODEL NUMBER	PART NUMBER	REQUIRED NUMBER						
				H-0 J-0	K-0	L-0				
1	GEAR MOTOR	V06695AEAA	4A0897-02	1	1	x1				
		-	4A2193-01			o1				
2	BARRIER - GEAR MOTOR	GS	3A1037-01	1	1	1				
	FT SCREW	SS, 4 x 8	7F32-0408	2	2	2				
3	COUPLING – SPLINE	SS	418316-01	1	1	1				
4	HOUSING	BRASS	206013G03	1	1	1				
	HEX BOLT	GOLD STAINLESS, 6 x 20	7B02-0620	4	4	-				
	BOLT	-	458660-01			4				
	PLAIN WASHER	SS, Ø6.4 x Ø12.5 x t 1.6	7W22-0616	4	4	-				
	SPRING WASHER	SS, 6	7L22-0600	4	4	-				
5	“O” RING	G40	7616-G040	1	1	1				
6	MECHANICAL SEAL	HK9A-MS	432491-01	1	1	1				
7	RING (B)	NTKU-4	432494-01	1	1	1				
8	AUGER	SS	341448G01	1	1	1				
9	EVAPORATOR	-	340076G01	1	x1					
		-	2A1699G01		o1	1				
	SOCKET HEAD CAP SCREW	SS, 6 x 10	7S12-0610	4	4	4				
	SPLIT LOCK WASHER	SS, 6	7L22-0800	4	4	4				
10	EXTRUDING HEAD – 45N	SS	327141G01	1	1	1				
11	SOCKET HEAD CAP SCREW	SS, 8 x 14	429121-01	3	3	3				
12	WASHER	SS	453791-01	3	3	3				
13	CUTTER	SS	440905-01	1	1	1				
14	REDUCER	COPPER	420915-06	1	1	1				

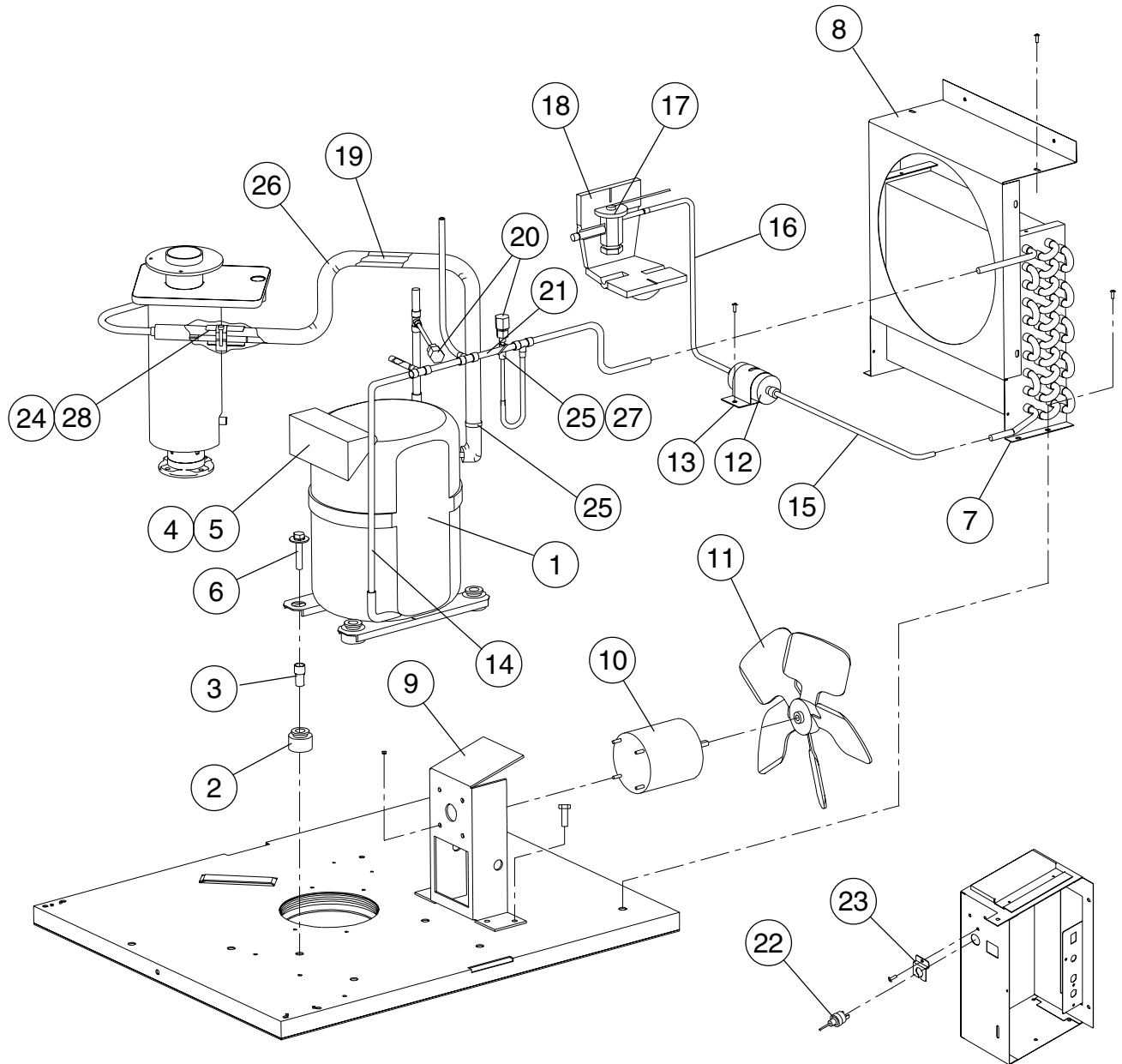

MODEL: F-450MAF/-C TITLE: C. REFRIGERATION UNIT										
INDEX NO.	DESCRIPTION	MATERIAL OR MODEL NUMBER	PART NUMBER	REQUIRED NUMBER						
				H-0 J-0	K-0	L-0				
1	COMPRESSOR	-	4A1272-01	1	1	x1				
		-	4A2300-01			o1				
2	GROMMET	027-0073-00	434403-01	4	4	4				
3	SPACER	027-0072-02	434404-01	4	4	4				
4	PROTECTOR	071-0527-04	4A1805-01	1	1	1				
5	PROTECTOR HOLDER	-	437339-01	1	1	1				
6	BOLT	8 x 45	437889-01	4	4	4				
7	CONDENSER	602380	2A0923-01	1	1	1				
	FT SCREW	SS, 4 x 8	7F32-0408	3	3	3				
8	SHROUD	GS	2A0908-01	1	1	1				
	T2 SCREW	4 x 8	7P31-0408	6	6	6				
9	FAN MOTOR BRACKET	GS	3A0828-01	1	1	1				
	HEX HEAD BOLT W/WASHER	SS, 5 x 12	7B0230512	4	4	4				
10	FAN MOTOR	U90 B1 7191-1031	440911-01	1	1	1				
	SELF-LOCKING NUT	No. 8-32	7N2110832	4	4	4				
11	FAN BLADE	AD10CW32	444898-01	1	1	1				
12	DRIER	A-TCH-032S	4A1113-01	1	1	1				
13	DRIER BRACKET	GS	445847-01	1	1	1				
	FT SCREW	SS, 4 x 8	7F32-0408	1	1	1				
14	COPPER TUBE (A) – HIGH SIDE	COPPER	2A0927G01	1	1	1				
15	COPPER TUBE (B) – HIGH SIDE	COPPER	4A1289-01	1	1	1				
16	COPPER TUBE (C) – HIGH SIDE	COPPER	3A0847-01	1	1	1				
17	EXPANSION VALVE	AN15C	4A1117-01	1	1	1				
18	EXPANSION VALVE COVER	PE FOAM	4A1168-01	1	1	1				

MODEL: F-450MAF/-C TITLE: C. REFRIGERATION UNIT										
INDEX NO.	DESCRIPTION	MATERIAL OR MODEL NUMBER	PART NUMBER	REQUIRED NUMBER						
				H-0 J-0	K-0	L-0				
19	COPPER TUBE (B) – LOW SIDE	COPPER	3A0844G01	1	1	1				
20	ACCESS VALVE	-	446715-01	2	x2					
		-	457729-01		o2	2				
21	COPPER TUBE – ACCESS VALVE	COPPER	4A1282G01	1	1	1				
22	PRESSURE SWITCH	ACB-ZUB04	433441-05	1	1	1				
23	PRESSURE SWITCH BRCKT.	GS	434938-01	1	1	1				
	T2 SCREW	4 x 8	7P31-0408	1	1	1				
24	CLAMP	O8	443461-01	1	1	1				
25	CABLE TIE	CV-150	7920-0003	9	9	9				
26	INSULATION TUBE	L=130	7762-2949	1	1	1				
27	INSULATION TUBE	L=30	7762-0717	1	1	1				
28	HOLDER/EXP. VALVE – ½	SS	3A0112-01	1	1	1				

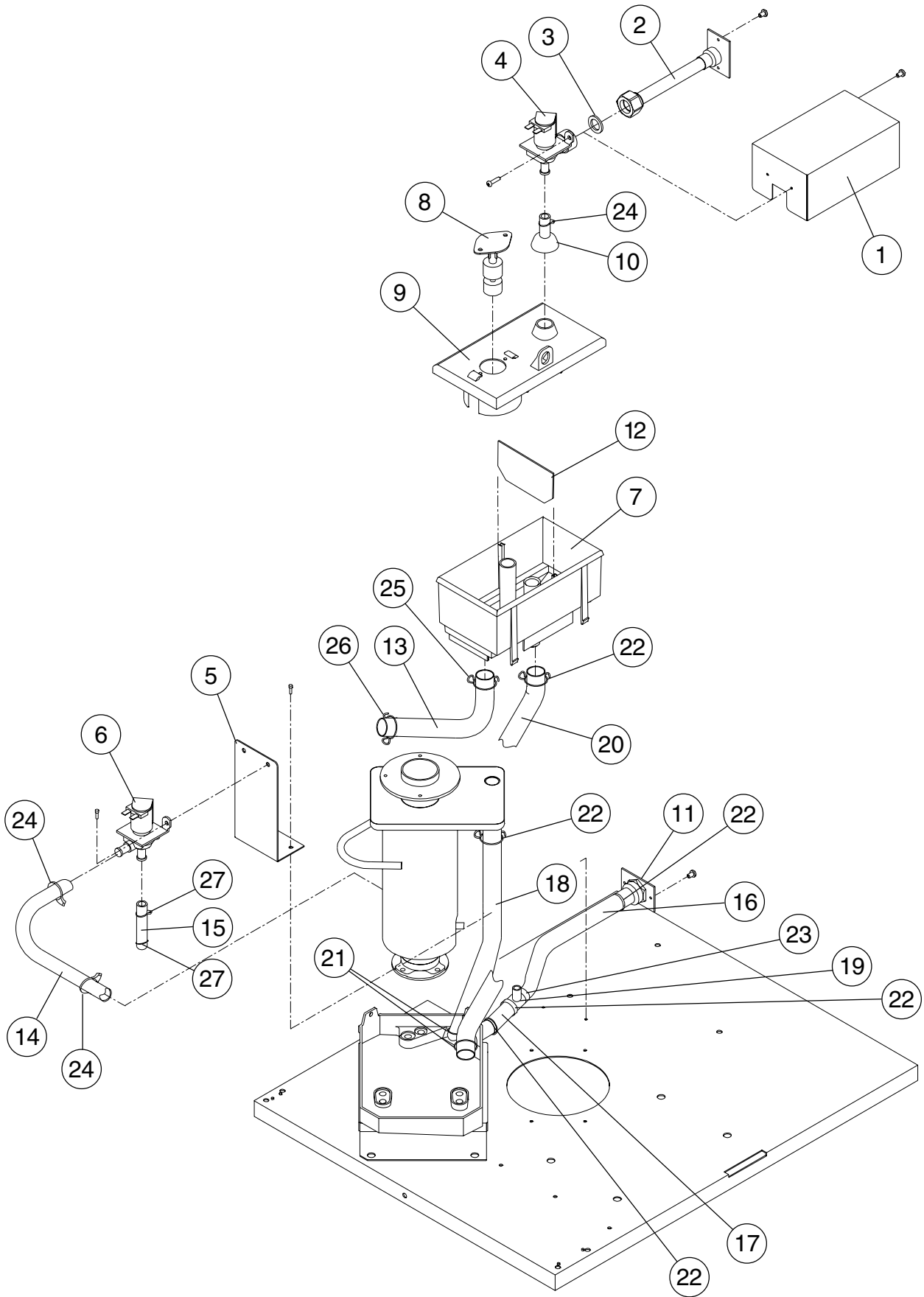

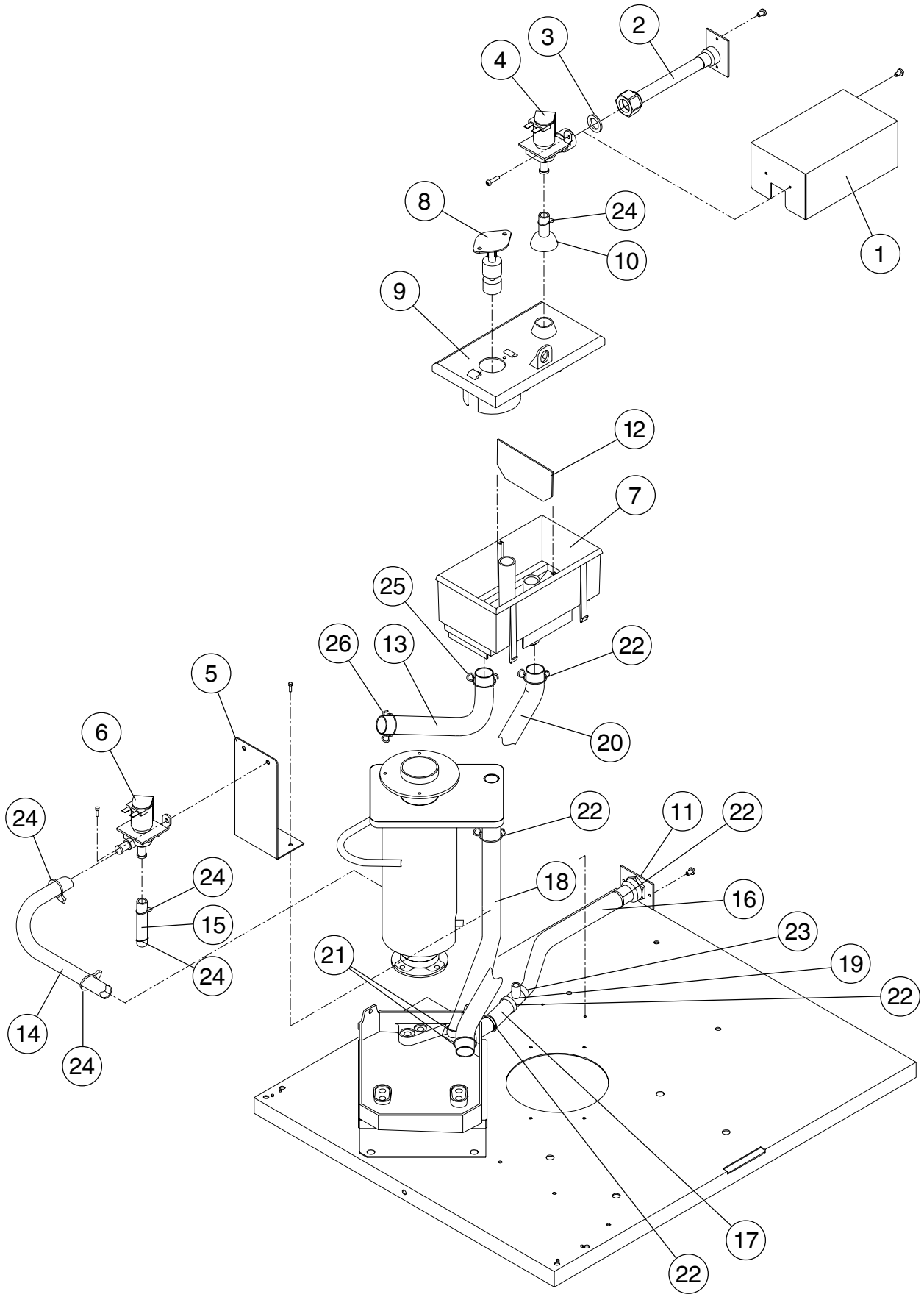

MODEL: F-450MAF/-C TITLE: D. WATER CIRCUIT										
INDEX NO.	DESCRIPTION	MATERIAL OR MODEL NUMBER	PART NUMBER	REQUIRED NUMBER						
				H-0 J-0	K-0	L-0				
1	WATER VALVE BRACKET	GS	3A0553-01	1	1	1				
	T2 SCREW	4 x 8	7P31-0408	3	3	3				
2	WATER SUPPLY PIPE	COPPER	4A0891G01	1	1	1				
	T2 SCREW	4 x 8	7P31-0408	4	4	4				
3	WASHER	K-59963	4A0867-01	1	1	1				
4	WATER VALVE	S-30	4A0865-01	1	1	1				
5	DRAIN VALVE BRACKET	GS	4A1264-01	1	1	1				
	FT SCREW	SS, 4 x 8	7F32-0408	2	2	2				
6	WATER VALVE	S-60N	4A0866-01	1	x1					
		-	4A2077-01		o1	1				
	T2 SCREW	SS, 4 x 8	7P32-0408	4	4	4				
7	RESERVOIR	PP	2A0753-01	1	1	1				
8	FLOAT SWITCH	TW-1221-101	435490-01	1	1	1				
9	RESERVOIR COVER	PP	214810-01	1	1	1				
10	INLET-RESERVOIR	SI.R.	4A0869-01	1	1	1				
11	FITTING	COPPER	4A0776G01	1	1	1				
12	SEPARATOR – RESERVOIR	ABS	4A1255-01	1	1	1				
13	RESERVOIR HOSE	EPDM	4A1165-05	1	1	1				
14	VINYL HOSE	L=230	7730-0912	1	1	x1				
	SILICONE HOSE	L=230	7730I3896			o1				
15	VINYL HOSE	L=65	7730-1114	1	1	x1				
		L=65	7716-0913			o1				
16	VINYL HOSE	L=270	7716-2025	1	1	1				
17	VINYL HOSE	L=80	7716-2025	1	1	1				
18	VINYL HOSE	L=355	7725-1923	1	1	1				
19	TEE	PVC	4A1331-01	1	1	1				
20	SILICONE HOSE	L=340	7730-1822	1	1	1				
21	CABLE TIE	CV-150	7920-0003	2	2	2				

MODEL: F-450MAF/-C TITLE: D. WATER CIRCUIT											
INDEX NO.	DESCRIPTION	MATERIAL OR MODEL NUMBER	PART NUMBER	REQUIRED NUMBER							
				H-0 J-0	K-0	L-0					
22	HOSE CLAMP	2338 HC 953	4A2017-01	5	5	5					
23	HOSE CLAMP	2342 HC 1031	4A2017-02	1	1	1					
24	HOSE CLAMP	2314 HC 468	4A2017-04	3	3	x5					
		-	4A2017-08			o5					
25	HOSE CLAMP	2326 HC 672	4A2017-05	1	1	1					
26	HOSE CLAMP	2330 HC 750	4A2017-06	1	1	1					
27	HOSE CLAMP	2322 HC 593	4A2017-07	2	2	-					

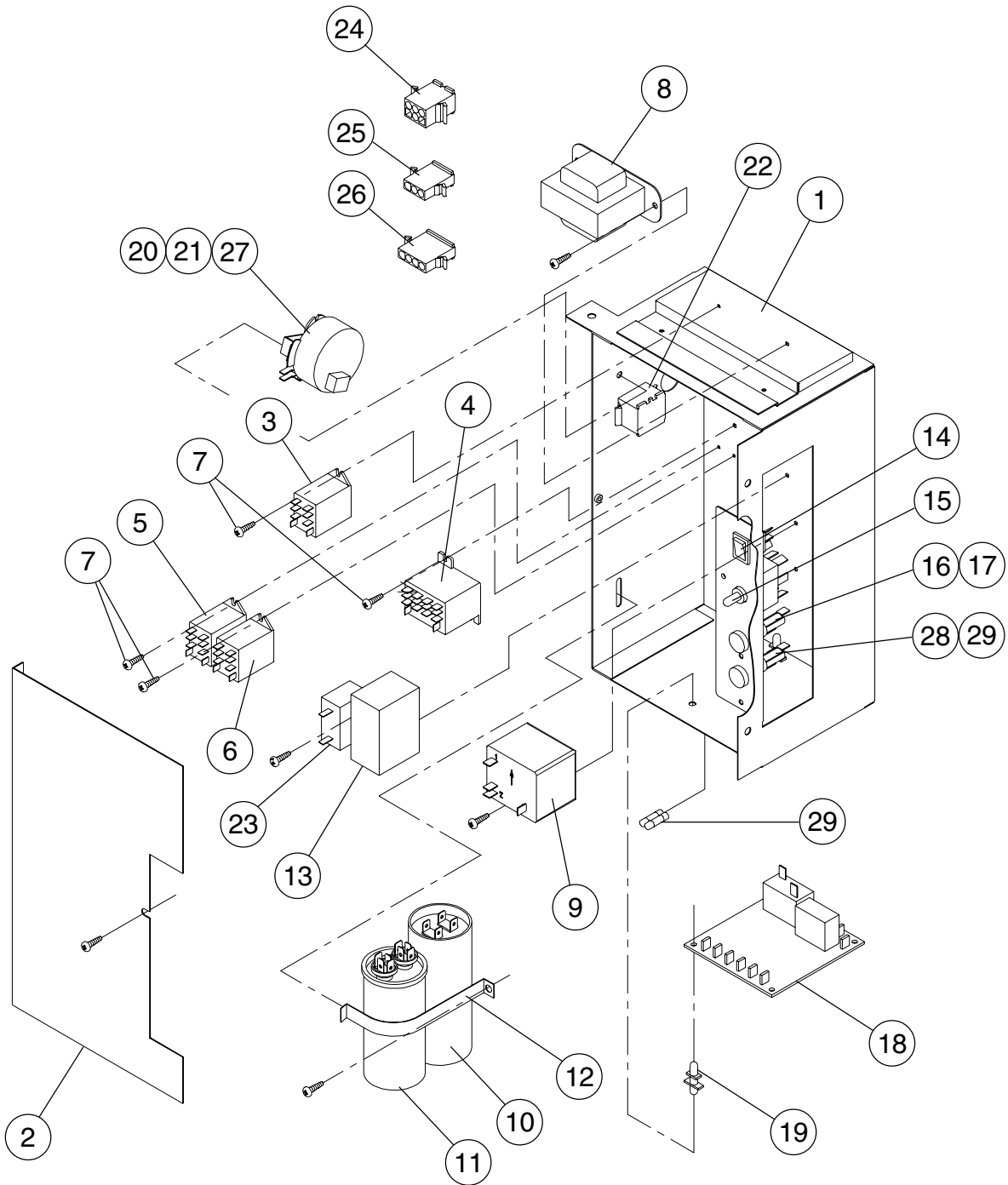

MODEL: F-450MAF/-C TITLE: E. CONTROL BOX ASSEMBLY										
INDEX NO.	DESCRIPTION	MATERIAL OR MODEL NUMBER	PART NUMBER	REQUIRED NUMBER						
				H-0 J-0	K-0	L-0				
1	CONTROL BOX	GS	2A0229G04	1	1	1				
	FT SCREW	SS, 4 x 8	7F32-0408	3	3	3				
2	COVER - CONTROL BOX	GS	3A0411-01	1	1	1				
	TRUSS HEAD SCREW	SS, 4 x 8	7C32-0408	2	2	2				
3	RELAY	LY2F AC24V	406132-03	1	1	1				
4	RELAY	LY4F AC24V	406133-04	1	1	1				
5	RELAY	LY1F AC220/240V	418271-05	1	1	1				
6	RELAY	LY1F AC120V	418271-03	1	1	1				
7	TAPPING SCREW	3 x 8	431415-01	8	8	8				
8	TRANSFORMER	BE141625GEK	4A0557-01	1	1	1				
	T2 SCREW	4 x 8	7P31-0408	2	2	2				
9	STARTER	3ARR3CT5M5	434172-04	1	1	x1				
		-	4A1107-11			o1				
	T2 SCREW	4 x 8	7P31-0408	1	1	1				
10	CAPACITOR - STARTING	3535 B7 C0243 A115A4	3A0076-10	1	1	1				
11	CAPACITOR	X386S (HG01)	439943-04	1	1	1				
12	STRAP	GS	434580-10	1	1	1				
	T2 SCREW	4 x 8	7P31-0408	1	1	1				
13	CAPACITOR	UP33B126 UWF	4A0894-01	1	1	1				
	T2 SCREW	4 x 8	7P31-0408	1	1	1				
14	ROCKER SWITCH	62111929-0-0-N	4A0558-01	1	1	1				
15	TOGGLE SWITCH	-	4A0567-01	1	1	x1				
		-	4A2332-01			o1				
16	FUSE HOLDER	HTB921	4A0892-01	1	1	1				
17	FUSE	AGC-1 1A 250V	4A0893-01	1	1	1				
18	TIMER BOARD	H2AA144C01	437305-01	1	1	1				
19	BOARD SUPPORT	CBL5 37 - M	4A0336-03	4	4	4				

MODEL: F-450MAF/-C TITLE: E. CONTROL BOX ASSEMBLY										
INDEX NO.	DESCRIPTION	MATERIAL OR MODEL NUMBER	PART NUMBER	REQUIRED NUMBER						
				H-0 J-0	K-0	L-0				
20	TIMER	-	4A0889-01	1	1	1				
21	SCREW	32 x 3/8	4A0898-01	1	1	1				
22	9P PLUG HOUSING	3191-9P-201	412832-02	1	1	1				
23	CAPACITOR	UP25B505UEF	443192-02	1	1	1				
	T2 SCREW	4 x 8	7P31-0408	1	1	1				
24	6P PLUG HOUSING	3191-6P-201	412832-03	1	1	1				
25	3P PLUG HOUSING	3191-3P-201	412832-06	2	2	2				
26	4P PLUG HOUSING	3191-4P-201	412832-05	1	1	1				
27	CONNECTOR	-	4A0899-02	1	1	1				
28	FUSE HOLDER	HTB-92M	4A0892-02	1	1	1				
29	FUSE	GMD 1.5A	4A0893-04	3	3	3				

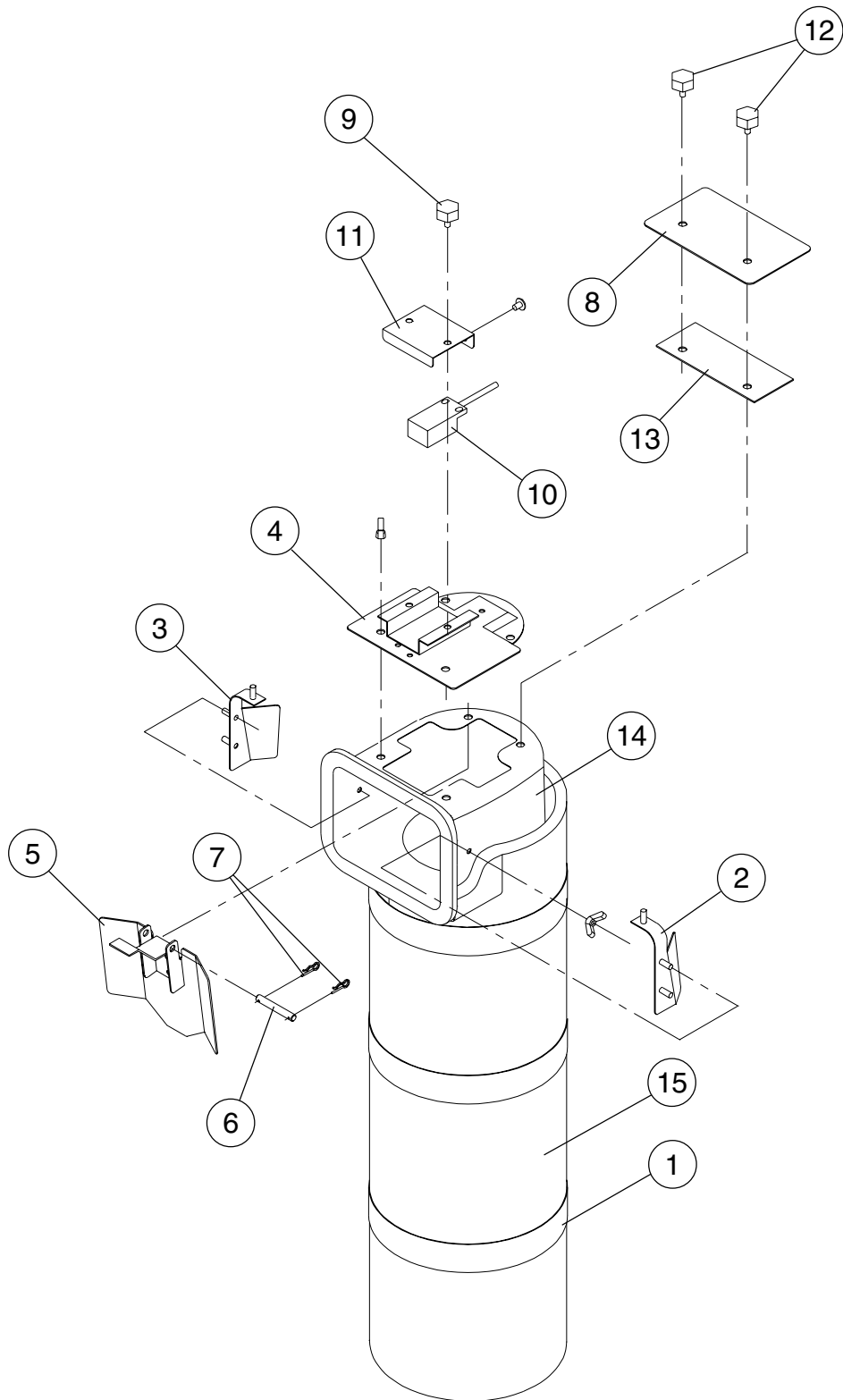

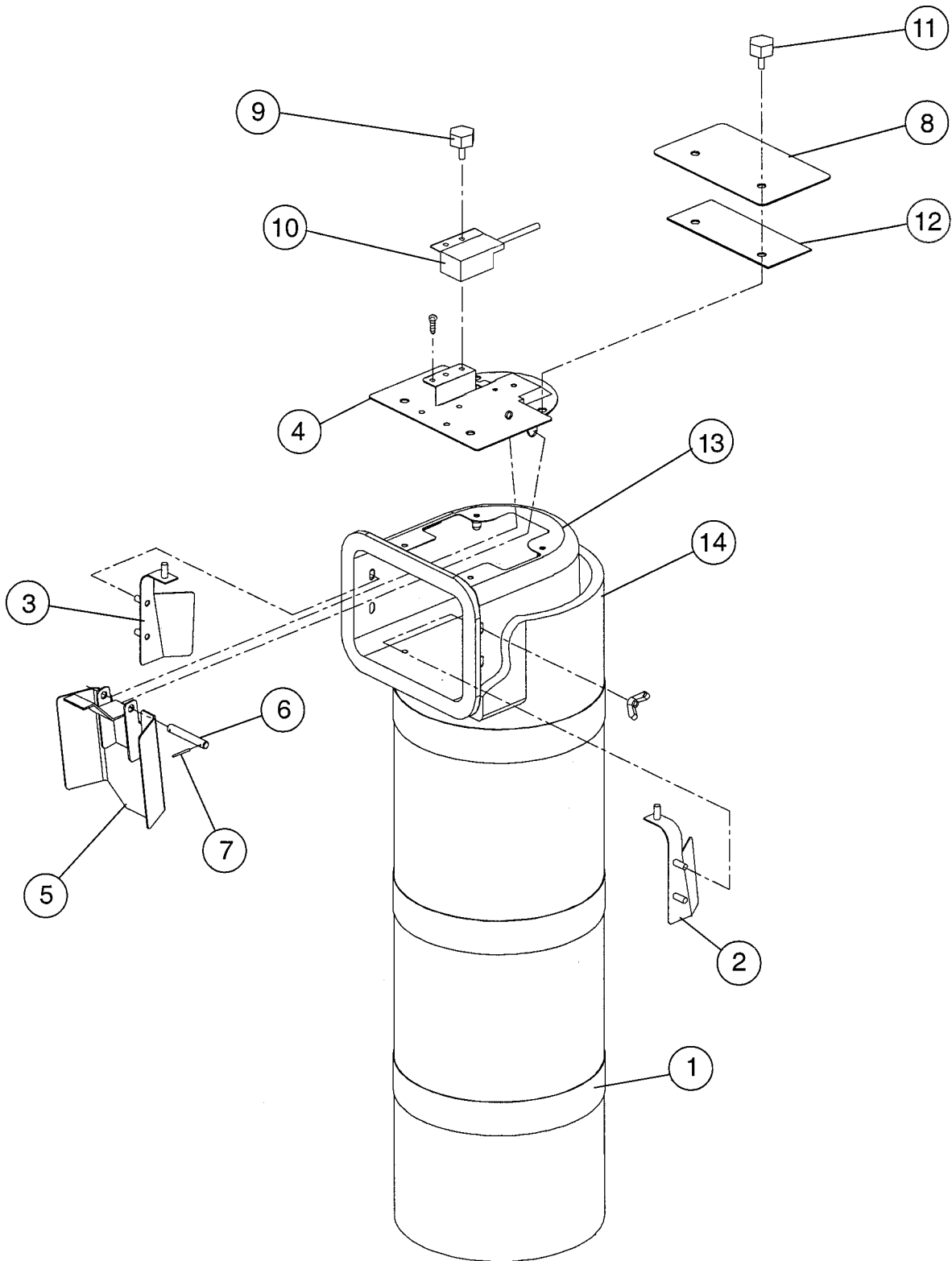

MODEL: F-450MAF TITLE: F. CHUTE ASSEMBLY										
INDEX NO.	DESCRIPTION	MATERIAL OR MODEL NUMBER	PART NUMBER	REQUIRED NUMBER						
				H-0 J-0	K-0	L-0				
1	TIE	PA	436531G01	3	3	3				
2	BAFFLE-CHUTE (A)	SS	3A0400G01	1	1	1				
	WING NUT	SS, 4	7E12-0400	6	6	6				
3	BAFFLE-CHUTE (B)	SS	3A0399G01	1	1	1				
4	BIN CONTROL	SS	338043G02	1	-					
		SS	3A1535G01		1	x1				
	BIN CONTROL ASSEMBLY	SS	3A1744G01			o1				
5	ACTUATOR	SS	436848G01	1	1	1				
6	SHAFT	SS	436851-01	1	1	1				
7	SNAP PIN	SS, SSP-5	715S-0005	2	2	2				
8	PLATE	SS	438336-01	1	-					
		SS	4A2039-01		1	1				
9	THUMB SCREW	ABS, SS	415949G04	2	2	2				
10	PROXIMITY SWITCH	RS-601	427223-01	1	-					
		-	4A2033-01		1	1				
11	COVER-SWITCH	SS	451870-01	1	-					
	TRUSS HEAD SCREW	SS, 4X8	7C32-0408	1	1	1				
12	THUMB SCREW	ABS, SS	415949G09	2	2	2				
13	PACKING	EPDM	441217-01	1	1	1				
14	CHUTE	PE	2A1308-01	1	1	1				
15	INSULATION CHUTE	PE FOAM	2A0989-01	1	1	1				

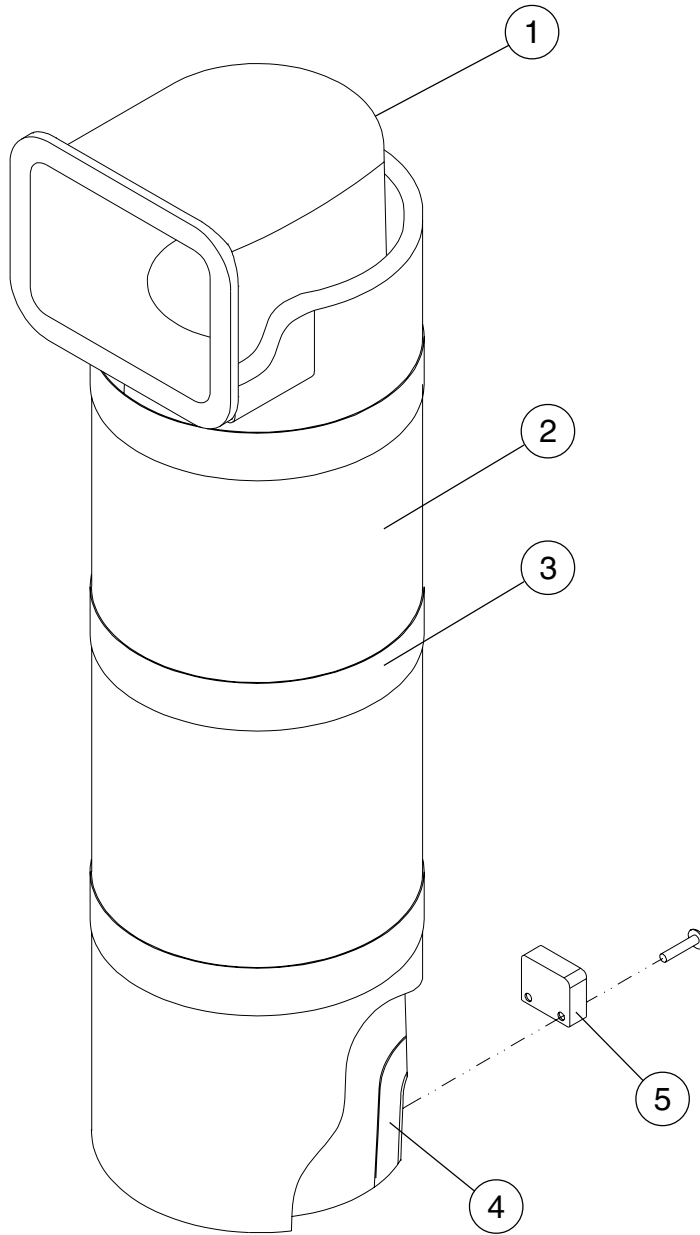

MODEL: F-450MAF-C TITLE: F. CHUTE ASSEMBLY										
INDEX NO.	DESCRIPTION	MATERIAL OR MODEL NUMBER	PART NUMBER	REQUIRED NUMBER						
				H-0 J-0	K-0	L-0				
1	CHUTE	PE	2A0925-01	1	1	1				
2	INSULATION – CHUTE	PE FOAM	2A0989-01	1	1	1				
3	TIE	PA	436531G01	3	3	3				
4	SENSOR HOUSING	PE	2A0996-01	1	1	1				
5	PHOTO-ELECTRIC SENSOR	UZD12	4A1173-01	1	1	1				
	CROSS RECESSED PAN HEAD TAPPING SCREW	TYPE1, NO.4, L= 3/4"	7C1111434	2	2	2				

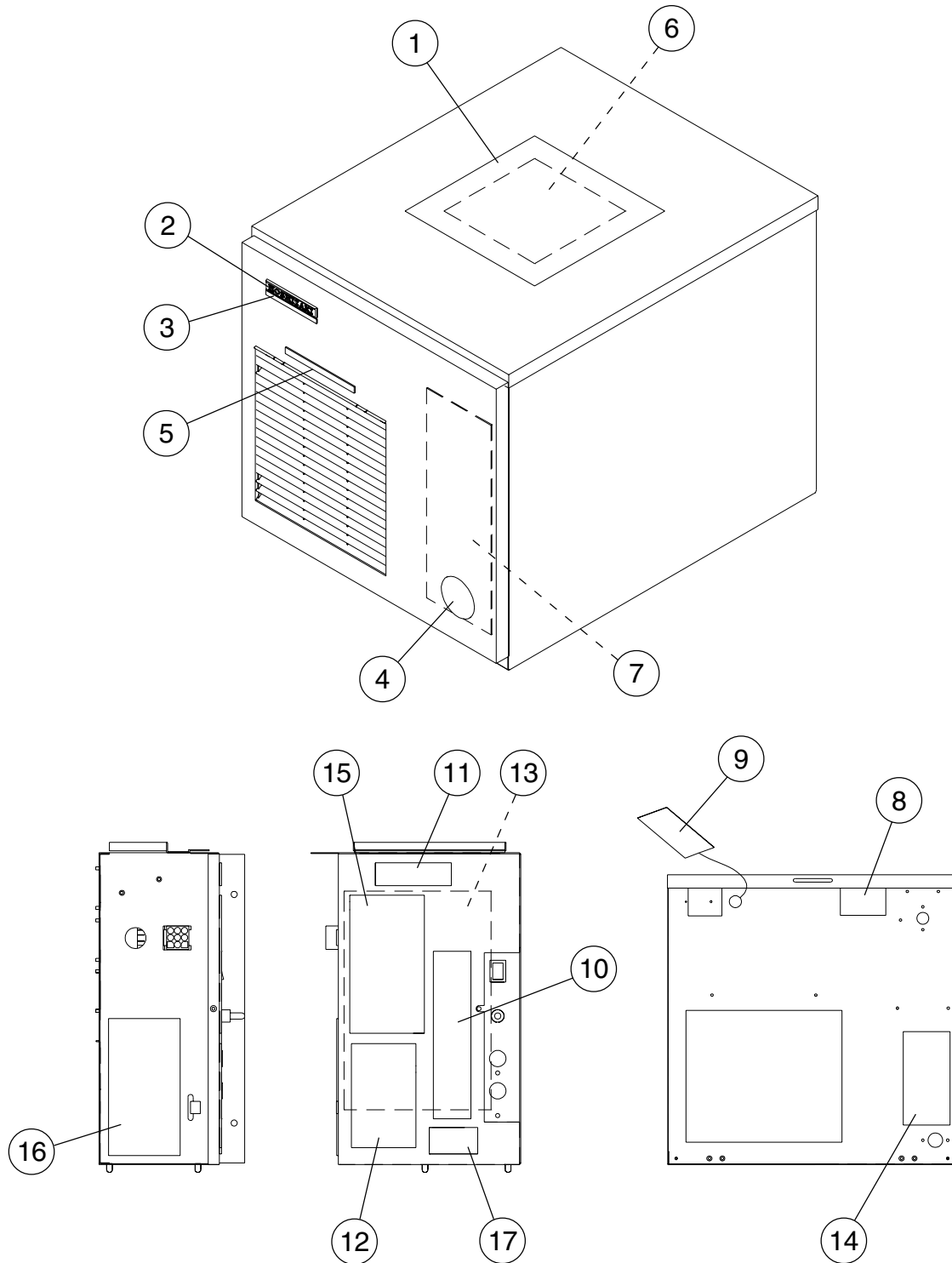

MODEL: F-450MAF TITLE: G. LABEL LOCATION										
INDEX NO.	DESCRIPTION	MATERIAL OR MODEL NUMBER	PART NUMBER	REQUIRED NUMBER						
				H-0 J-0	K-0	L-0				
1	INSTRUCTION SHEET	PAPER	2A1054-01	1	1	1				
2	EMBLEM	PETP FILM	4A0560-01	1	1	1				
3	MODEL NUMBER LABEL	PETP FILM	4A1321-01	1	1	1				
4	LABEL - PENGUIN - HA - L	PETP FILM	4A0526-02	1	1	1				
5	LABEL - AIR FILTER	PETP FILM	426177-01	1	1	1				
6	INSTRUCTION LABEL	PVC FILM	326371-01	1	1	1				
7	LABEL - CLEANING	PVC FILM	326370-01	1	1	1				
8	NAMEPLATE	PES FILM	4A1323-01	1	1	1				
9	TAG - WARNING: ELECTRICAL CONNECTION	PAPER	435005-01	1	1	1				
10	CONTROL LABEL	PVC FILM	4A1613-01	1	1	1				
11	LABEL - R404A	PES FILM	4A0960-01	1	1	1				
12	CAUTION LABEL (E)	PVC FILM	439145-01	1	1	1				
13	WIRING LABEL	PVC FILM	2A1830-01	1	1	1				
14	INSTRUCTION SHEET	PAPER	433523-01	1	1	1				
15	CAUTION LABEL (H)	PVC FILM	439148-01	1	1	1				
16	RATING LABEL	PES FILM	4A1669-01	1	1	1				
17	LABEL (GM) – FUSE	PVC FILM	4A1614-01	1	1	1				

MODEL: F-450MAF-C TITLE: G. LABEL LOCATION										
INDEX NO.	DESCRIPTION	MATERIAL OR MODEL NUMBER	PART NUMBER	REQUIRED NUMBER						
				H-0 J-0	K-0	L-0				
1	INSTRUCTION SHEET	PAPER	2A1054-01	1	1	1				
2	EMBLEM	PETP FILM	4A0560-01	1	1	1				
3	MODEL NUMBER LABEL	PETP FILM	4A1321-02	1	1	1				
4	LABEL - PENGUIN - HA - L	PETP FILM	4A0526-02	1	1	1				
5	LABEL - AIR FILTER	PETP FILM	426177-01	1	1	1				
6	INSTRUCTION LABEL	PVC FILM	326371-01	1	1	1				
7	LABEL - CLEANING	PVC FILM	326370-01	1	1	1				
8	NAMEPLATE	PES FILM	4A1499-01	1	1	1				
9	TAG - WARNING: ELECTRICAL CONNECTION	PAPER	435005-01	1	1	1				
10	CONTROL LABEL	PVC FILM	4A1613-01	1	1	1				
11	LABEL - R404A	PES FILM	4A0960-01	1	1	1				
12	CAUTION LABEL (E)	PVC FILM	439145-01	1	1	1				
13	WIRING LABEL	PVC FILM	2A1396-01	1	1	1				
14	INSTRUCTION SHEET	PAPER	433523-01	1	1	1				
15	CAUTION LABEL (H)	PVC FILM	439148-01	1	1	1				
16	RATING LABEL	PES FILM	4A1670-01	1	1	1				
17	LABEL (GM) – FUSE	PVC FILM	4A1614-01	1	1	1				

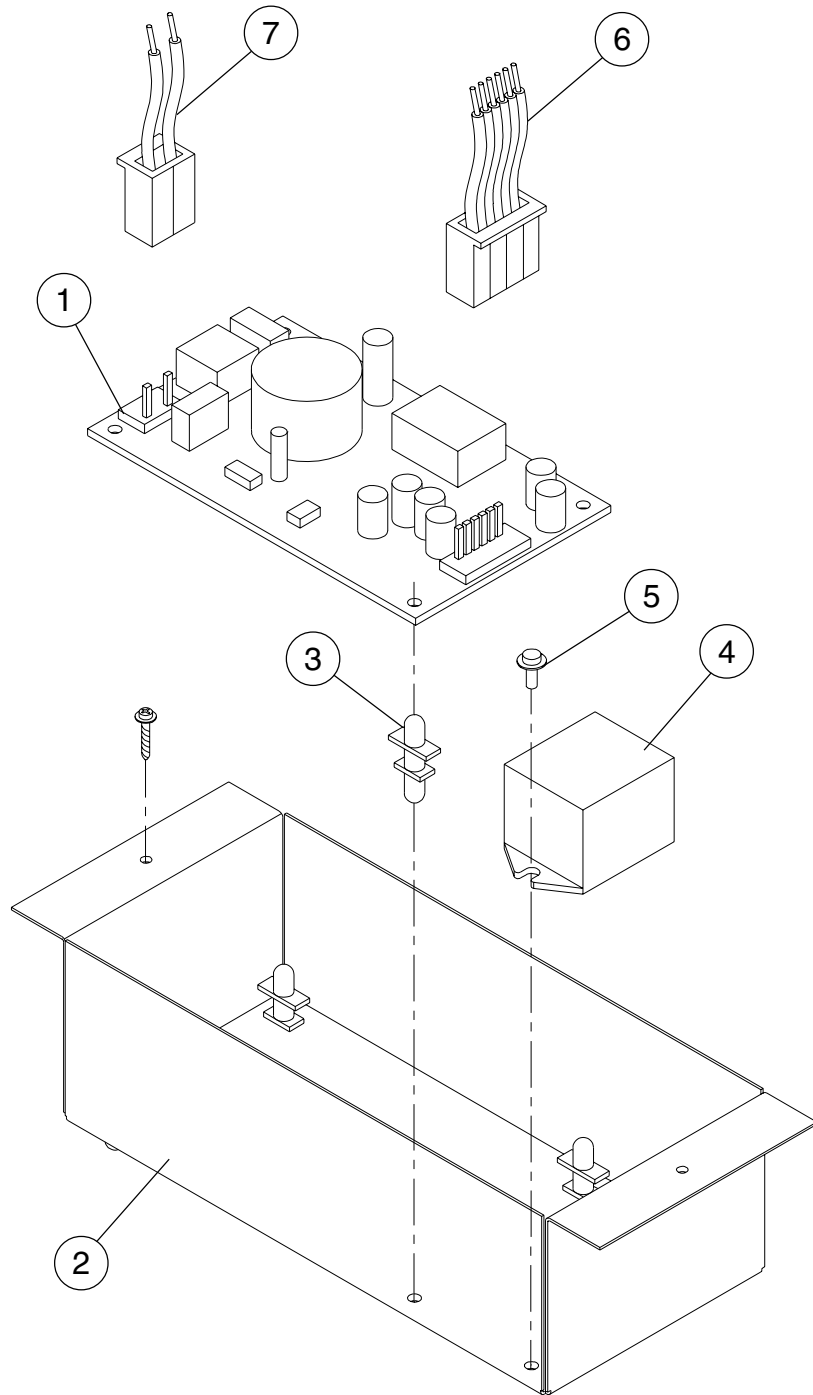

MODEL: F-450MAF-C TITLE: H. POWER SUPPLY ASSEMBLY										
INDEX NO.	DESCRIPTION	MATERIAL OR MODEL NUMBER	PART NUMBER	REQUIRED NUMBER						
				H-0 J-0	K-0	L-0				
1	POWER SUPPLY	GLC40-24 1	4A1355-01	1	1	1				
2	POWER SUPPLY HOUSING	GS	4A1316-01	2	2	2				
	FT SCREW	SS, 4 x 8	7F32-0408	1	1	1				
3	BOARD SUPPORT	CBLS37-M	4A0336-03	4	4	4				
4	RELAY	JA1a-TM-DC24V	4A1382-01	1	1	1				
5	TAPPING SCREW	3 x 8	431415-01	2	2	2				
6	LINE CONNECTOR	09053061	4A1317-01	1	1	1				
7	LINE CONNECTOR	09503031	4A1317-02	1	1	1				
	CRIMP TERMINAL (MOLEX)	08500189	8101-18PG	4	4	4				

MODEL: F-450MAF/-C TITLE: J. ACCESSORIES										
INDEX NO.	DESCRIPTION	MATERIAL OR MODEL NUMBER	PART NUMBER	REQUIRED NUMBER						
				H-0 J-0	K-0	L-0				
1	INSTRUCTION MANUAL	PAPER	91A2BA10A	1	1	1				
2	UNIVERSAL BRACE	GS	4A0363-01	2	2	2				
	HEX HEAD BOLT	SS, 5 x 12	7B02-0512	2	2	2				
3	LABEL - FASTENER	-	427122-01	1	1	1				
	TRUSS HEAD SCREW	SS, 4X8	7C32-0408	1	1	1				