



**HOSHIZAKI
MODULAR FLAKER**



MODEL

F-800MAH(-C)

F-800MWH(-C)

PARTS LIST

F-800MAH	L-0	APRIL, 2001
F-800MAH-C	L-0	
F-800MWH	L-0	MAY, 2001
F-800MWH-C	L-0	MAY, 2001

MATERIAL ABBREVIATIONS

ALUMINUM

AL = Aluminum

COPPER

CU = Copper

PLASTIC

ABS = Acrylonitrile -butadiene - styrene
 AC = Polyacetal
 EVA = Ethylene vinyl acetate
 PA = Polyamide = Nylon
 PC = Polycarbonate
 PE = Polyethylene
 PES = Polyester
 PETP = Polyethylene terephthalate = Tetlon
 PP = Polypropylene
 PS = Polystyrene
 PTFE = Polytetrafluoroethylene = Teflon
 PUR = Polyurethane
 PVC = Polyvinyl chloride

RUBBER

VN = Vinyl Nitrile
 EPDM = EP rubber
 NBR = Nitrile butadiene rubber
 NR = Natural rubber
 NP = Neoprene
 SI.R = Silicone rubber
 SY.R = Synthetic rubber
 EPH = Epichlorohydrin

STEEL

GS = Galvanized steel
 SS = Stainless steel
 PS = Plated steel
 PAS = Primed steel

AUXILIARY CODE

Ex.1

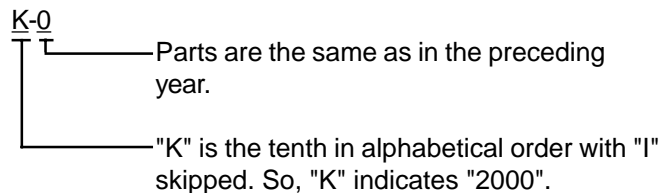

(Note) - = Part deleted.

x = Part deleted and replaced by "o" (interchangeable) part.

Ex.2

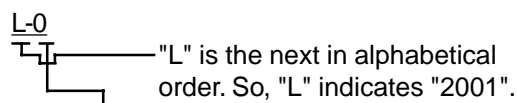

o = New part for "x" in the same auxiliary code.

Ex.3

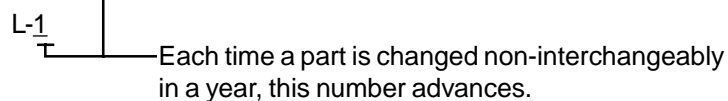

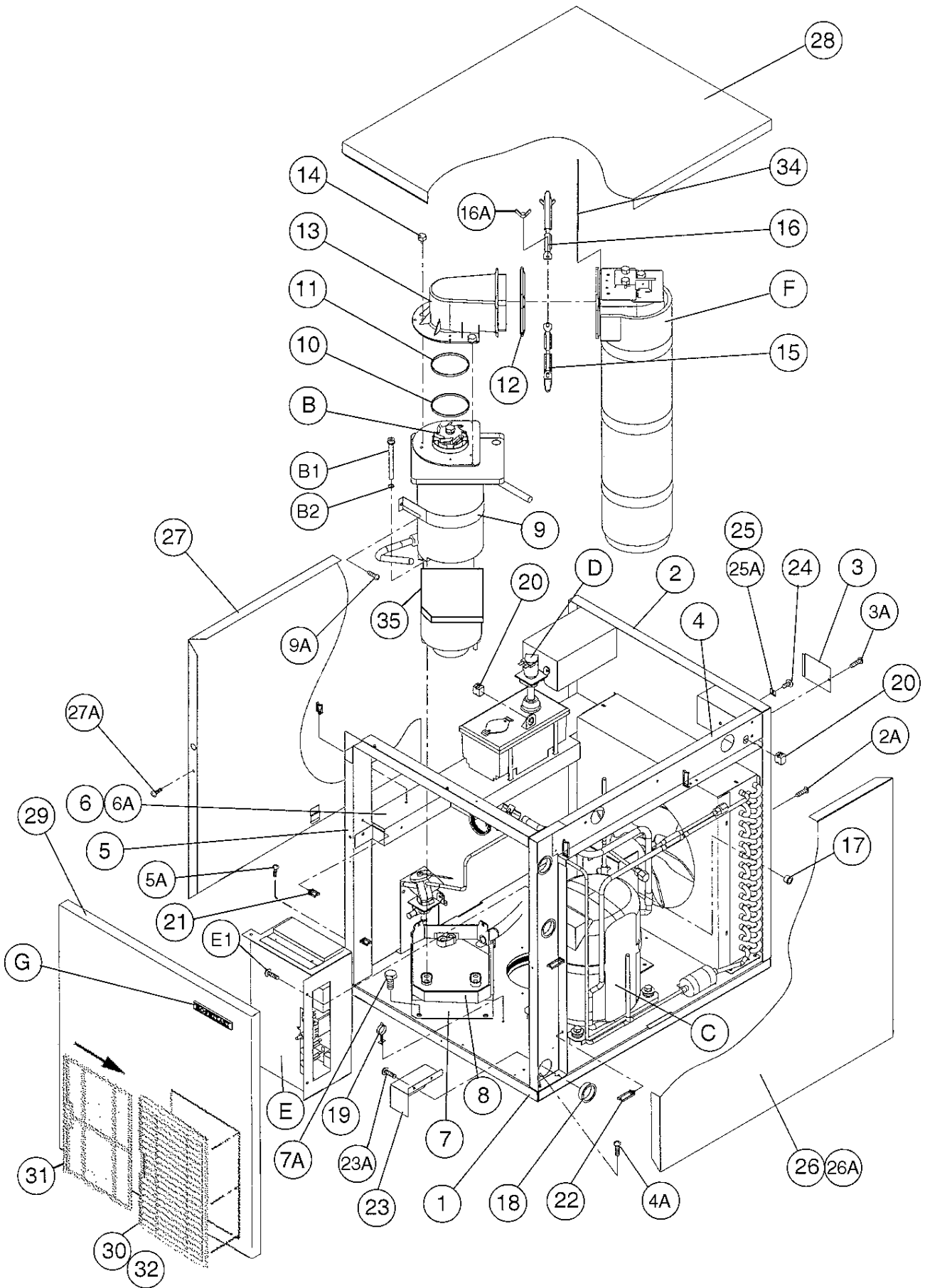

MODEL: F-800MAH		TITLE: A. ICE FLAKER ASSEMBLY						
INDEX NO.	DESCRIPTION	MATERIAL OR MODEL NUMBER	PART NUMBER	REQUIRED NUMBER				
				L-0				
B	ICE MAKING UNIT	-	3A0962A01	1				
B1	SOCKET HEAD HEX BOLT	8X95, SS	7S12-0895	3				
B2	SPRING WASHER	8, SS	7L22-0800	3				
C	REFRIGERATION UNIT	-	2A1000A02	1				
D	WATER CIRCUIT	-	2A0968A01	1				
E	CONTROL BOX ASSEMBLY	-	2A1045A05	1				
E1	TRUSS HEAD SCREW	4X8	7C31-0408	3				
F	CHUTE ASSEMBLY	-	2A0941A02	1				
G	LABEL LOCATION	-	2A2081A01	1				

MODEL: F-800MAH(-C)		TITLE: A. ICE FLAKER ASSEMBLY						
INDEX NO.	DESCRIPTION	MATERIAL OR MODEL NUMBER	PART NUMBER	REQUIRED NUMBER				
				L-0				
1	CHASSIS	GS	2A1176G01	1				
2	REAR PANEL	GS	2A0322G02	1				
2A	T2 SCREW	4X8	7P31-0408	4				
3	JUNCTION BOX COVER	GS	433410-01	1				
3A	T2 SCREW	4X8	7P31-0408	1				
4	SIDE FRAME (R)	GS	2A1047G01	1				
4A	TRUSS HEAD SCREW	4X8	7C31-0408	2				
5	FRONT FRAME	GS	3A0324G01	1				
5A	TRUSS HEAD SCREW	4X8	7C31-0408	2				
6	RESERVOIR BRACKET	GS	2A1060-01	1				
6A	T2 SCREW	4X8	7P31-0408	4				
7	BRACKET – GEAR MOTOR	GS	3A0396G01	1				
7A	HEX BOLT	8X12, SS	7B02-0812	2				
8	DRAIN PAN	ABS	323765G02	1				
9	STRAP	GS	4A1474-01	1				
9A	T3 SCREW	5X12	7G31-0512	2				
10	RING	PA	432661-02	1				
11	“O” RING	G70	7616-G070	1				
12	PACKING-SPOUT	EPDM	321037-01	1				
13	SPOUT	PC	104797-01	1				
14	THUMBSCREW	SS, ABS	415949G04	3				
15	STRAP	SS	321038G02	1				
16	STRAP	SS	328703-02	1				
16A	WING NUT	6, SS	7E12-0600	2				
17	BUSHING	SB-1500-21	420470-09	1				
18	BUSHING	SB-1500-21	420470-06	3				
19	CLAMP	WS75-75-C	4A0337-12	3				
20	BUSHING	SR-30-1	420472-03	2				
21	WIRE SADDLE	LWS-2NS	4A0338-02	5				
22	WIRE SADDLE	LWS-4NS	4A0338-04	4				

MODEL: F-800MAH(-C)		TITLE: A. ICE FLAKER ASSEMBLY						
INDEX NO.	DESCRIPTION	MATERIAL OR MODEL NUMBER	PART NUMBER	REQUIRED NUMBER				
				L-0				
23	BARRIER	GS	4A0688-01	1				
23A	TRUSS HEAD SCREW	4X8	7C31-0408	2				
24	SCREW-GROUNDING	BRASS	433304-02	1				
25	SQUARE WASHER	BRASS	433537-02	1				
25A	TRUSS HEAD SCREW	4X8	7C31-0408	1				
26	SIDE PANEL (RIGHT)	SS	2A2070G01	1				
26A	TRUSS HEAD SCREW	4X8, SS	7C32-0408	1				
27	SIDE PANEL (LEFT)	SS	2A2069G01	1				
27A	TRUSS HEAD SCREW	4X8, SS	7C32-0408	1				
28	TOP PANEL	SS	2A2064-01	1				
29	FRONT PANEL	SS	2A2068-01	1				
30	LOUVER (A)	PP	1A0547-01	1				
31	AIR FILTER (A)	-	2A2062G01	1				
32	PUSH RETAINER	-	4A2414-01	3				
33	CABLE TIE	CV-150	7920-0003	1				
34	BRACKET-CHUTE	SS	4A1712-01	1				
35	BARRIER – GEAR MOTOR	GS	3A1823-01	1				

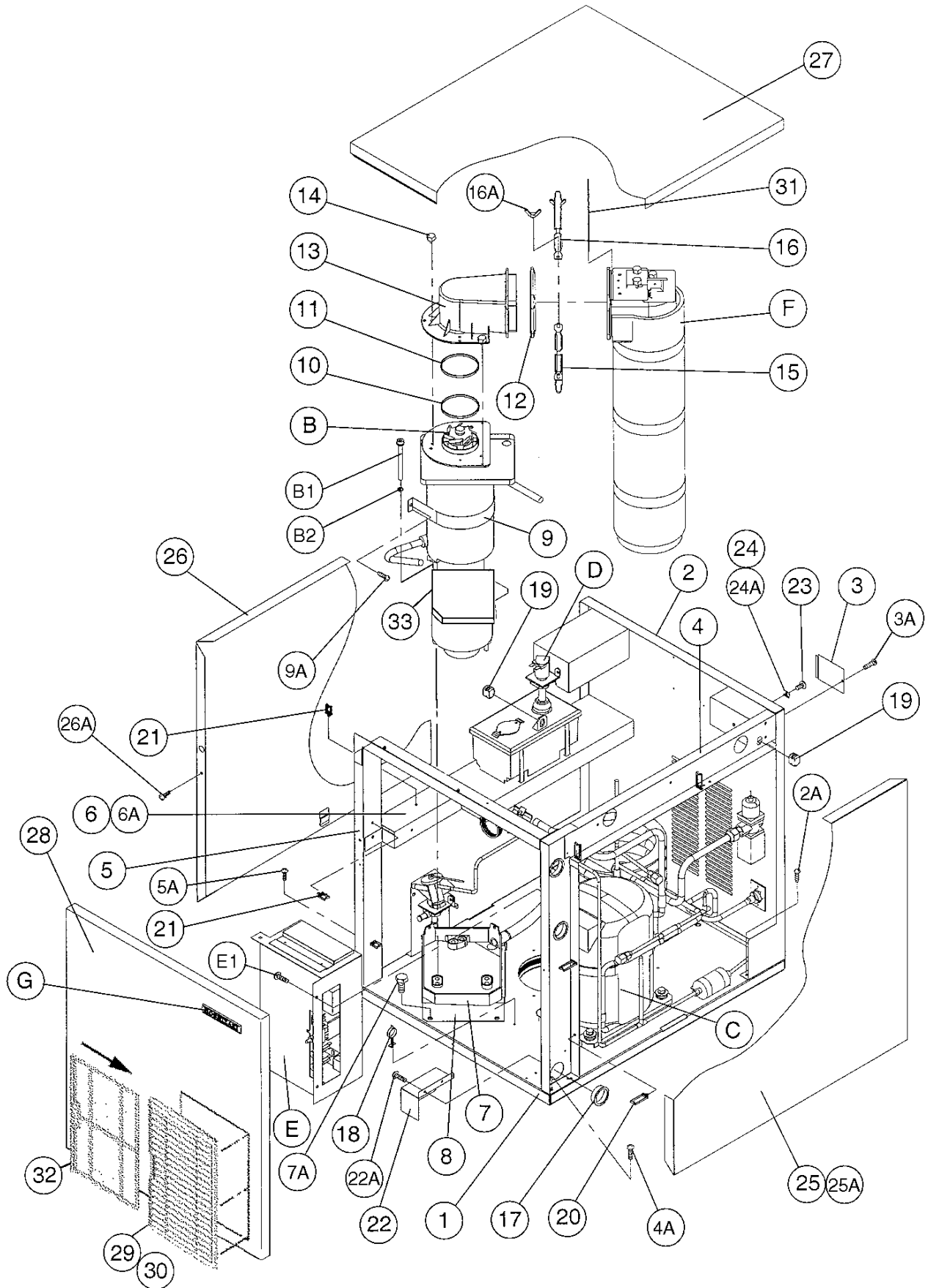

MODEL: F-800MWH		TITLE: A. ICE FLAKER ASSEMBLY						
INDEX NO.	DESCRIPTION	MATERIAL OR MODEL NUMBER	PART NUMBER	REQUIRED NUMBER				
				L-0				
B	ICE MAKING UNIT	-	3A0962A01	1				
B1	SOCKET HEAD HEX BOLT	8X95, SS	7S12-0895	3				
B2	SPRING WASHER	8, SS	7L22-0800	3				
C	REFRIGERATION UNIT	-	2A1024A02	1				
D	WATER CIRCUIT	-	2A0968A01	1				
E	CONTROL BOX ASSEMBLY	-	2A1045A06	1				
E1	TRUSS HEAD SCREW	4X8	7C31-0408	3				
F	CHUTE ASSEMBLY	-	2A0941A02	1				
G	LABEL LOCATION	-	2A2081A03	1				

MODEL: F-800MWH-C					TITLE: A. ICE FLAKER ASSEMBLY				
INDEX NO.	DESCRIPTION	MATERIAL OR MODEL NUMBER	PART NUMBER	REQUIRED NUMBER					
				L-0					
B	ICE MAKING UNIT	-	3A0962A02	1					
B1	SOCKET HEAD HEX BOLT	8X95, SS	7S12-0895	3					
B2	SPRING WASHER	8, SS	7L22-0800	3					
C	REFRIGERATION UNIT	-	2A1024A02	1					
D	WATER CIRCUIT	-	2A0968A01	1					
E	CONTROL BOX ASSEMBLY	-	2A1045A06	1					
E1	TRUSS HEAD SCREW	4X8	7C31-0408	3					
F	CHUTE ASSEMBLY	-	2A0941A02	1					
G	LABEL LOCATION	-	2A2081A04	1					

MODEL: F-800MWH(-C)				TITLE: A. ICE FLAKER ASSEMBLY				
INDEX NO.	DESCRIPTION	MATERIAL OR MODEL NUMBER	PART NUMBER	REQUIRED NUMBER				
				L-0				
1	CHASSIS	GS	2A1176G01	1				
2	REAR PANEL	GS	2A1012G01	1				
2A	T2 SCREW	4X8	7P31-0408	4				
3	JUNCTION BOX COVER	GS	433410-01	1				
3A	T2 SCREW	4X8	7P31-0408	1				
4	SIDE FRAME (R)	GS	2A1047G01	1				
4A	TRUSS HEAD SCREW	4X8	7C31-0408	2				
5	FRONT FRAME	GS	3A0324G01	1				
5A	TRUSS HEAD SCREW	4X8	7C31-0408	2				
6	RESERVOIR BRACKET	GS	2A1059-01	1				
6A	T2 SCREW	4X8	7P31-0408	4				
7	BRACKET – GEAR MOTOR	GS	3A0396G01	1				
7A	HEX BOLT	8X12, SS	7B02-0812	2				
8	DRAIN PAN	ABS	323765G02	1				
9	STRAP	GS	4A1474-01	1				
9A	T3 SCREW	5X12	7G31-0512	2				
10	RING	PA	432661-02	1				
11	“O” RING	G70	7616-G070	1				
12	PACKING-SPOUT	EPDM	321037-01	1				
13	SPOUT	PC	104797-01	1				
14	THUMBSCREW	SS, ABS	415949G04	3				
15	STRAP	SS	321038G02	1				
16	STRAP	SS	328703-02	1				
16A	WING NUT	6, SS	7E12-0600	2				
17	BUSHING	SB-1500-21	420470-06	3				
18	CLAMP	WS75-75-C	4A0337-12	3				
19	BUSHING	SR-30-1	420472-03	2				
20	WIRE SADDLE	LWS-2NS	4A0338-02	5				
21	WIRE SADDLE	LWS-4NS	4A0338-04	4				
22	BARRIER	GS	4A0688-01	1				
22A	TRUSS HEAD SCREW	4X8	7C31-0408	2				

MODEL: F-800MWH(-C)				TITLE: A. ICE FLAKER ASSEMBLY				
INDEX NO.	DESCRIPTION	MATERIAL OR MODEL NUMBER	PART NUMBER	REQUIRED NUMBER				
				L-0				
24	SQUARE WASHER	BRASS	433537-02	1				
24A	TRUSS HEAD SCREW	4X8	7C31-0408	1				
25	SIDE PANEL (RIGHT)	SS	2A2070G01	1				
25A	TRUSS HEAD SCREW	4X8, SS	7C32-0408	1				
26	SIDE PANEL (LEFT)	SS	2A2069G01	1				
26A	TRUSS HEAD SCREW	4X8, SS	7C32-0408	1				
27	TOP PANEL	SS	2A2064-01	1				
28	FRONT PANEL	SS	2A2068-01	1				
29	LOUVER (A)	PP	1A0547-01	1				
30	PUSH RETAINER	-	4A2414-01	3				
31	BRACKET-CHUTE	SS	4A1712-01	1				
32	AIR FILTER (A)	-	2A2062G01	1				
33	BARRIER – GEAR MOTOR	GS	3A1823-01	1				

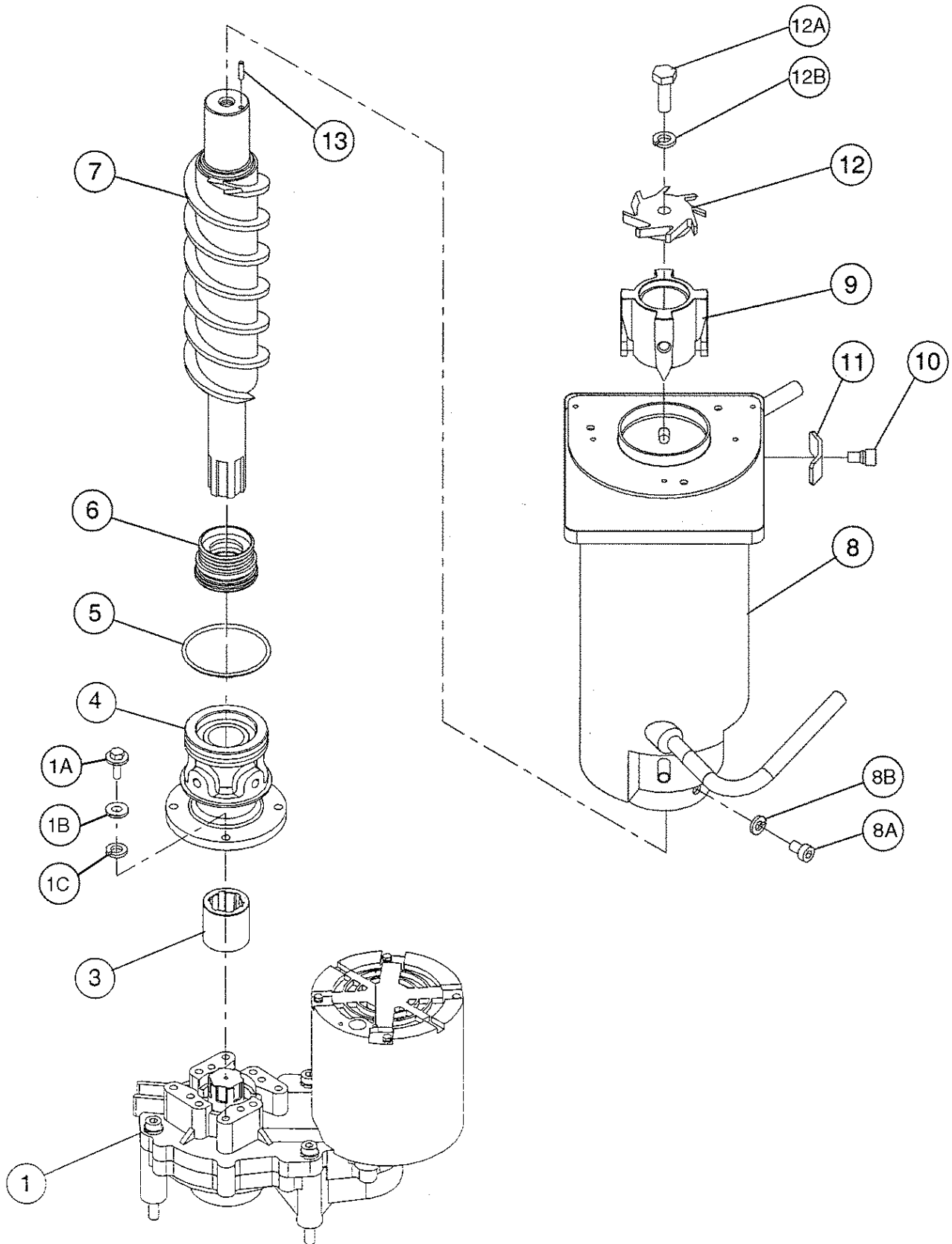

MODEL: F-800MAH, MWH		TITLE: B. ICE MAKING UNIT							
INDEX NO.	DESCRIPTION	MATERIAL OR MODEL NUMBER	PART NUMBER	REQUIRED NUMBER					
				L-0					
1	GEAR MOTOR	V06695-ACAA	4A2194-01	1					
1A	BOLT	6X20	458660-01	4					
1B	PLAIN WASHER	6.4X12.5X1.6, SS	7W22-0616	4					
1C	SPRING WASHER	6, SS	7L22-0600	4					
2	-	-	-						
3	COUPLING - SPLINE	SS	4A1297-01	1					
4	HOUSING	BRASS	2A0947G01	1					
5	"O" RING	G65	7616-G065	1					
6	MECHANICAL SEAL	HK9A-MN	432492-01	1					
7	AUGER	SS	2A0932G02	1					
8	EVAPORATOR	-	2A1227G01	1					
8A	SOCKET HEAD CAP SCREW	8X12, SS	7S12-0812	4					
8B	SPLIT LOCK WASHER	8, SS	7L22-0800	4					
9	EXTRUDING HEAD / 70F	SS	3A2175G01	1					
10	SOCKET HEAD CAP SCREW	SS, M10X15	429121-01	4					
11	WASHER	SS	427184-01	4					
12	CUTTER	SS	317071-02	1					
12A	HEX HEAD BOLT	10X30, SS	7B02-1030	1					
12B	SPLIT LOCK WASHER	10, SS	7L22-1000	1					
13	DOWEL PIN	SS, 4 x 16	713S-0416	1					

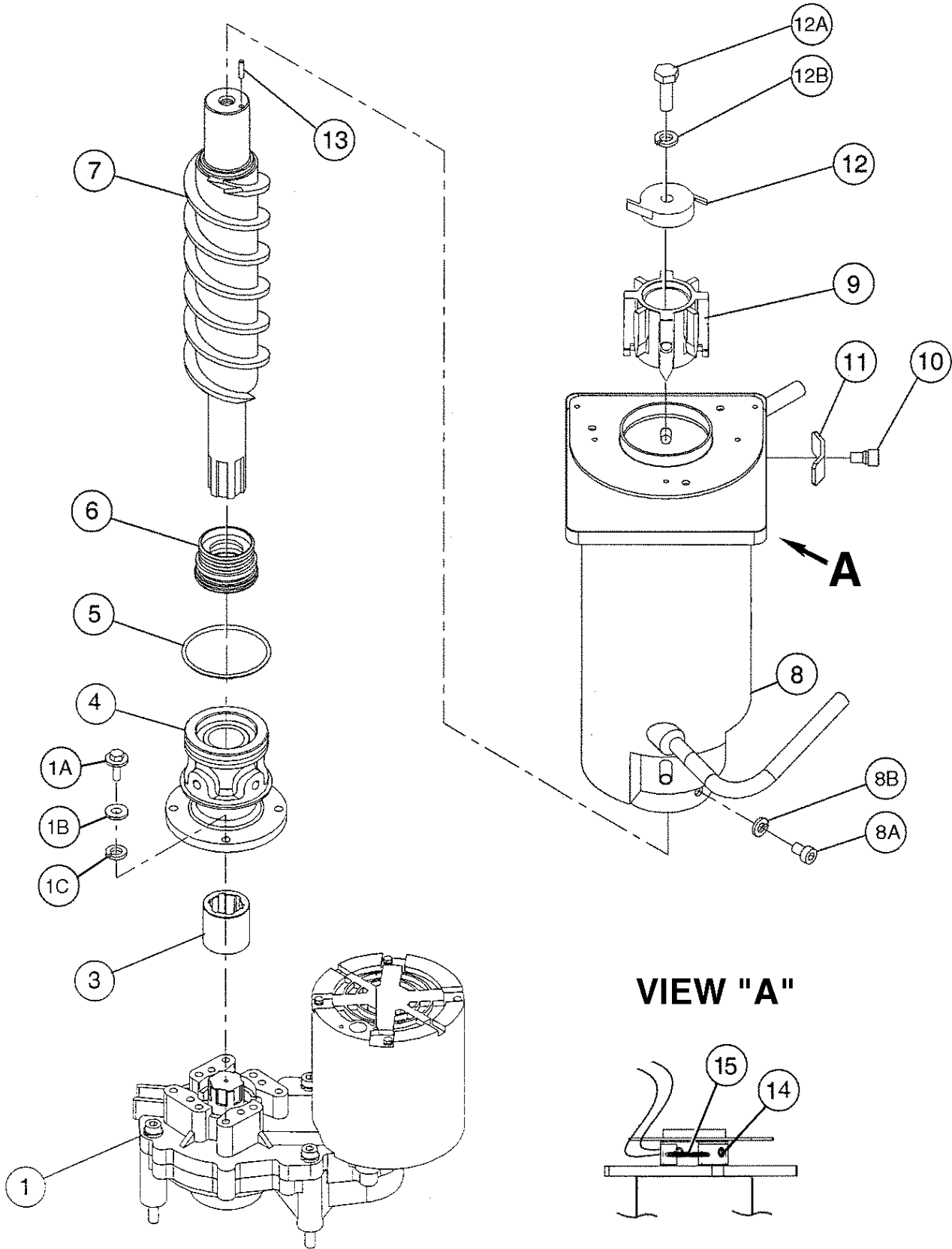

MODEL: F-800MAH-C, MWH-C				TITLE: B. ICE MAKING UNIT				
INDEX NO.	DESCRIPTION	MATERIAL OR MODEL NUMBER	PART NUMBER	REQUIRED NUMBER				
				L-0				
1	GEAR MOTOR	V06695-ACAA	4A2194-01	1				
1A	BOLT	6X20	458660-01	4				
1B	PLAIN WASHER	6.4X12.5X1.6, SS	7W22-0616	4				
1C	SPRING WASHER	6, SS	7L22-0600	4				
2	-	-	-					
3	COUPLING - SPLINE	SS	4A1297-01	1				
4	HOUSING	BRASS	2A0947G01	1				
5	"O" RING	G65	7616-G065	1				
6	MECHANICAL SEAL	HK9A-MN	432492-01	1				
7	AUGER	SS	2A0932G02	1				
8	EVAPORATOR	-	2A1227G01	1				
8A	SOCKET HEAD CAP SCREW	8X12, SS	7S12-0812	4				
8B	SPLIT LOCK WASHER	8, SS	7L22-0800	4				
9	EXTRUDING HEAD / 70F	SS	3A2176G01	1				
10	SOCKET HEAD CAP SCREW	SS, M10X15	429121-01	4				
11	WASHER	SS	427184-01	4				
12	CUTTER	SS	327145-01	1				
12A	HEX HEAD BOLT	10X30, SS	7B02-1030	1				
12B	SPLIT LOCK WASHER	10, SS	7L22-1000	1				
13	DOWEL PIN	SS, 4 x 16	713S-0416	1				
14	HEATER	-	4A2292-01	1				
15	SPRING	-	4A2292F01	1				

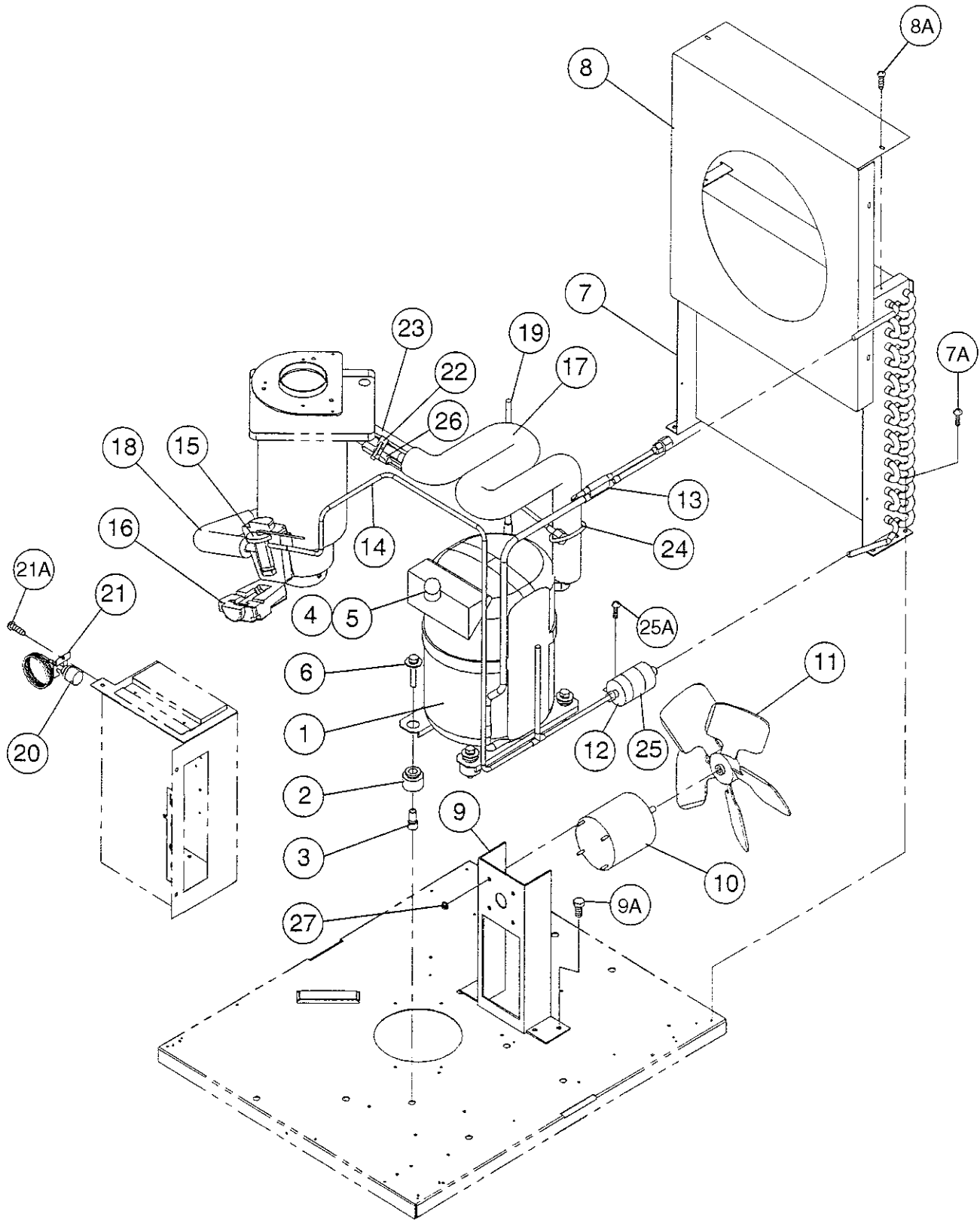

MODEL: F-800MAH(-C) TITLE: C. REFRIGERATION UNIT								
INDEX NO.	DESCRIPTION	MATERIAL OR MODEL NUMBER	PART NUMBER	REQUIRED NUMBER				
				L-0				
1	COMPRESSOR	RS55-C2E-CAA	4A1843-01	1				
2	GROMMET	027-0073-00	434403-01	4				
3	SPACER	027-0072-02	434404-01	4				
4	PROTECTOR	-	4A1877-01	1				
5	PROTECTOR HOLDER	-	4A1843F04	1				
6	BOLT	8X50	437889-01	4				
7	CONDENSER-AIR COOLED	971634C	2A0340-01	1				
7A	FT SCREW	4X8, SS	7F32-0408	4				
8	SHROUD	GS	2A0334-01	1				
8A	T2 SCREW	4X8	7P31-0408	6				
9	FAN MOTOR BRACKET	GS	327180-01	1				
9A	HEX HEAD BOLT W/WASHER	5X12, SS	7B0230512	4				
10	FAN MOTOR	U90B17190-1031	440911-01	1				
11	FAN BLADE	AD10CW32	444898-01	1				
12	DRIER	ATCH-032S	4A1113-01	1				
13	COPPER TUBE (A) - HIGH SIDE	COPPER	3A0945G01	1				
14	COPPER TUBE (B) -HIGH SIDE	COPPER	3A0946G01	1				
15	EXPANSION VALVE	AN-1-SC	4A1117-01	1				
16	EXPANSION VALVE COVER	PE FOAM	4A1168-01	1				
17	COPPER TUBE – LOW SIDE	COPPER	3A1820G01	1				
18	INSULATION TUBE	L=170	7762-1330	1				
19	COPPER TUBE-ACCESS VALVE	COPPER	4A1364G01	1				
20	PRESSURE SWITCH	ACB-2UB04	433441-05	1				
21	PRESSURE SWITCH BRACKET	GS	434938-01	1				
21A	T2 SCREW	4X8	7P31-0408	1				
22	CLAMP	-	443461-01	1				
23	INSULATION TUBE	L=130	7762-2943	1				
24	CABLE TIE	CV-150	7920-0003	10				
25	DRIER BRACKET	GS	445847-01	1				
25A	FT SCREW	4X8	7F31-0408	1				

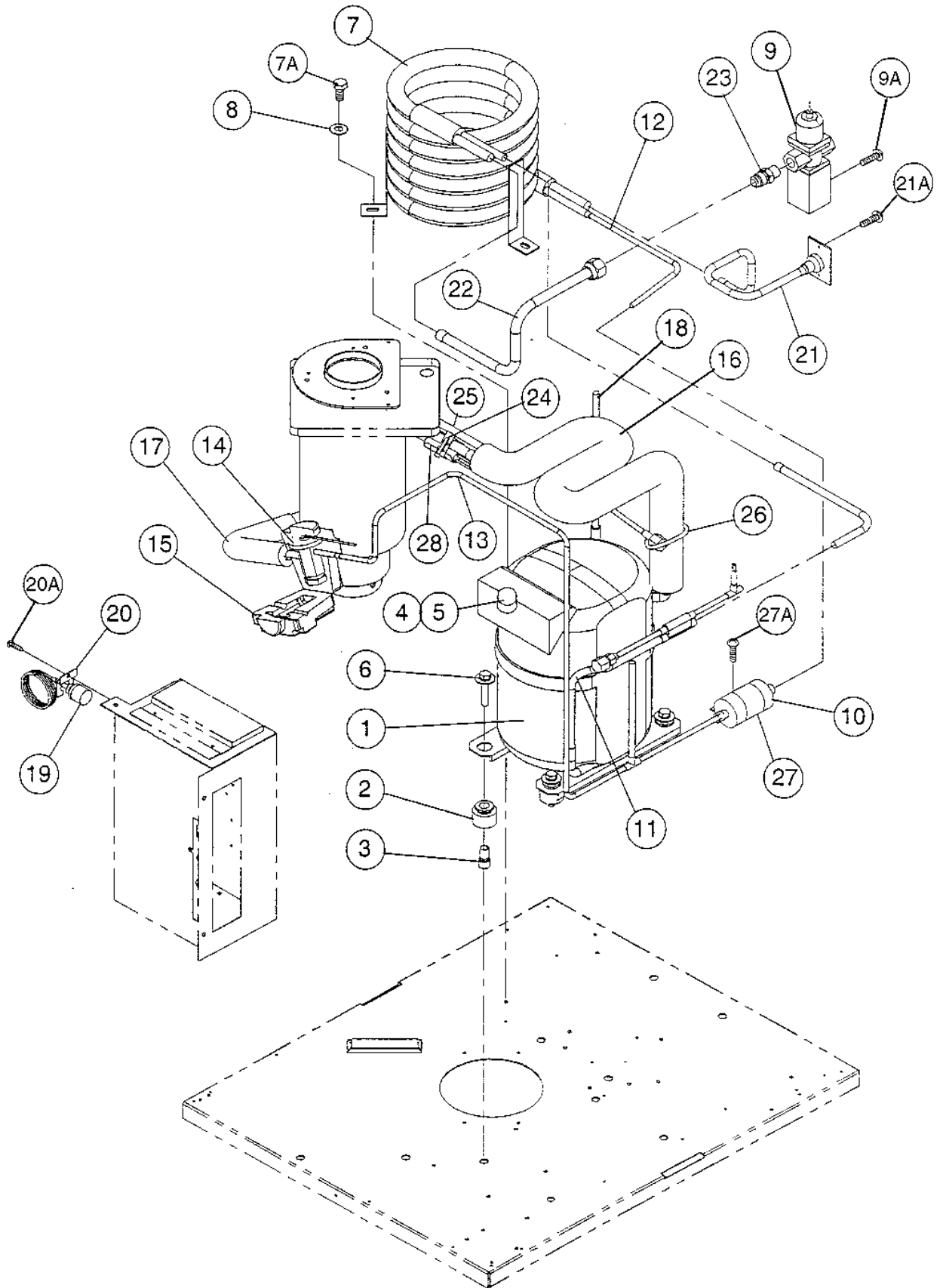

MODEL: F-800MWH(-C) TITLE: C. REFRIGERATION UNIT								
INDEX NO.	DESCRIPTION	MATERIAL OR MODEL NUMBER	PART NUMBER	REQUIRED NUMBER				
				L-0				
1	COMPRESSOR	R5S55C2E-CAA	4A1843-01	1				
2	GROMMET	027-0073-00	434403-01	4				
3	SPACER	027-0072-02	434404-01	4				
4	PROTECTOR	-	4A1877-01	1				
5	PROTECTOR HOLDER	-	4A1843F04	1				
6	BOLT	8X50	437889-01	4				
7	CONDENSER-WATER COOLED	-	212929-04	1				
7A	HEX BOLT W/WASHER (LF)	5X10, SS	7B0230510	3				
8	WASHER	-	4A0655-03	3				
9	WATER REGULATOR	V46EA-7	4A0911-04	1				
9A	TRUSS HEAD SCREW	4X8	7C31-0408	2				
10	DRIER	ATCH-032S	4A1113-01	1				
11	COPPER TUBE (A) - HIGH SIDE	COPPER	3A0958G01	1				
12	COPPER TUBE (B) - HIGH SIDE	COPPER	3A0946G01	1				
13	COPPER TUBE (C) - HIGH SIDE	COPPER	3A0959-01	1				
14	EXPANSION VALVE	AN-1-SC	4A1117-01	1				
15	EXPANSION VALVE COVER	PE FOAM	4A1168-01	1				
16	COPPER TUBE – LOW SIDE	COPPER	3A1820G01	1				
17	INSULATION TUBE	L=170	7762-1330	1				
18	COPPER TUBE - ACCESS VALVE	COPPER	4A1364G01	1				
19	PRESSURE SWITCH	ACB-2UB04	433441-05	1				
20	PRESSURE SWITCH BRACKET	GS	434938-01	1				
20A	T2 SCREW	4X8	7P31-0408	1				
21	COPPER TUBE (A) -WATER INLET	COPPER	3A0960G01	1				
21A	T2 SCREW	4X8	7P31-0408	2				
22	COPPER TUBE (B) -WATER OUTLET	COPPER	3A0961G01	1				
23	MALE CONNECTOR	48F-8-6	4A1087-01	1				
24	CLAMP	08	443461-01	1				
25	INSULATION TUBE	L=130	7762-2943	1				
26	CABLE TIE	CV-150	7920-0003	14				

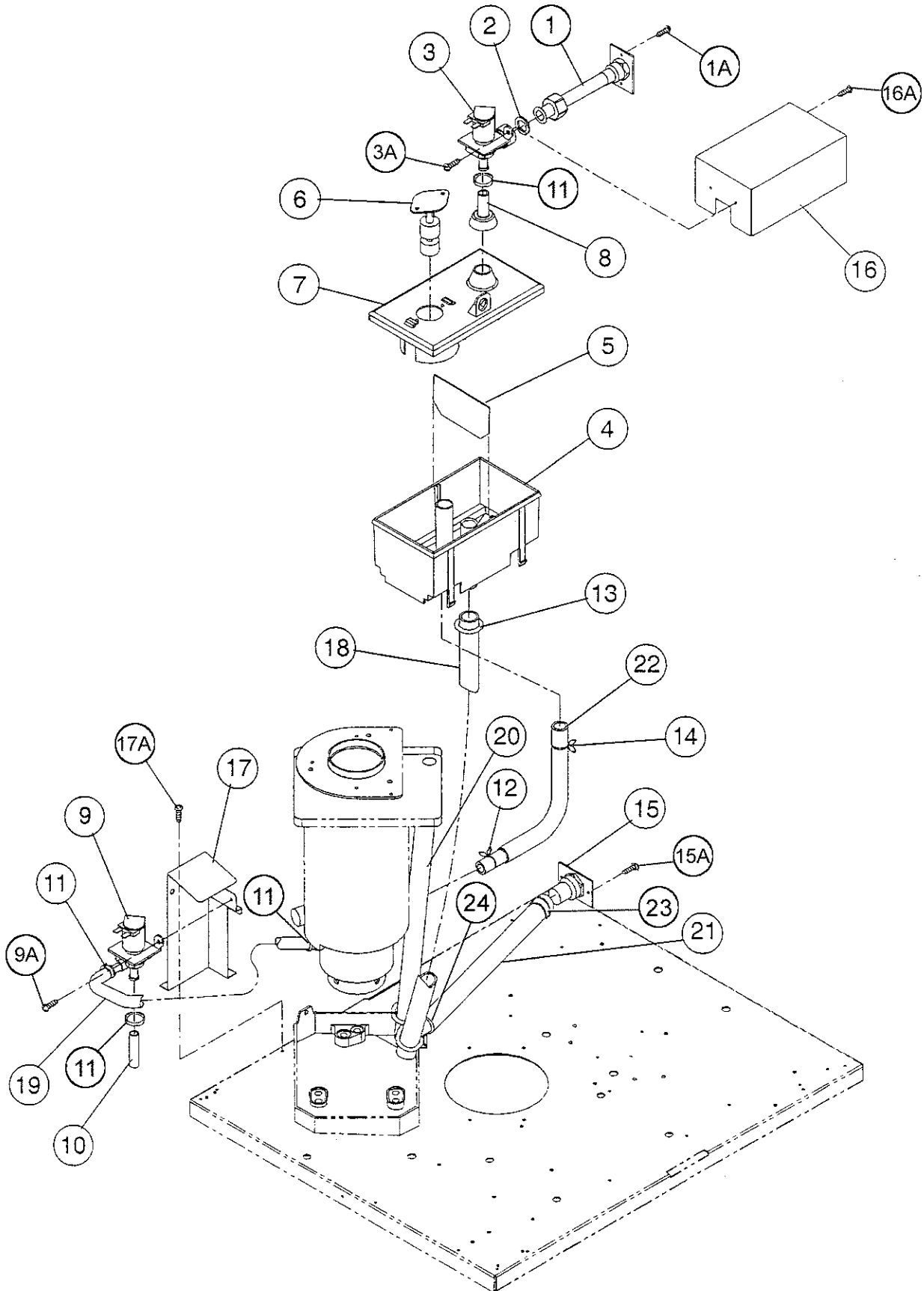

MODEL: F-800MAH(-C), MWH(-C)				TITLE: D. WATER CIRCUIT				
INDEX NO.	DESCRIPTION	MATERIAL OR MODEL NUMBER	PART NUMBER	REQUIRED NUMBER				
				L-0				
1	WATER SUPPLY PIPE	COPPER	4A0891G01	1				
1A	T2 SCREW	4X8	7P31-0408	2				
2	WASHER	K-59963	4A0867-01	1				
3	WATER VALVE	S-30	4A0865-01	1				
3A	T2 SCREW	4X8, SS	7P32-0408	2				
4	RESERVOIR	PP	2A0753-01	1				
5	SEPARATOR-RESERVOIR	ABS	4A1255-01	1				
6	FLOAT SWITCH	TW-1221-101	435490-01	1				
7	RESERVOIR COVER	PP	214810-01	1				
8	INLET- RESERVOIR	SI.R.	4A0869-01	1				
9	WATER VALVE	S-60N	4A2077-01	1				
9A	T2 SCREW	4X8	7P31-0408	2				
10	VINYL HOSE	L=40	7716-0913	1				
11	HOSE CLAMP	-	4A2017-08	4				
12	HOSE CLAMP	-	4A2017-05	1				
13	CABLE TIE	CV-150	7920-0003	4				
14	HOSE CLAMP	-	4A2017-06	1				
15	FITTING	COPPER	4A0776G01	1				
15A	T2 SCREW	4X8	7P31-0406	2				
16	WATER VALVE BRACKET	GS	3A0553-01	1				
16A	T2 SCREW	4X8	7P31-0408	3				
17	WATER VALVE BRACKET (D)	GS	3A0554-01	1				
17A	T2 SCREW	4X8	7P31-0408	2				
18	SILICONE HOSE	L=410	7730-1822	1				
19	SILICONE HOSE	L=225	7730I3896	1				
20	VINYL HOSE	L=430	7725-1923	1				
21	VINYL HOSE	L=390	7716-2025	1				
22	RESERVOIR HOSE	EPDM	4A1165-01	1				
23	HOSE CLAMP	-	4A2017-02	1				
24	HOSE CLAMP	-	4A2017-01	1				

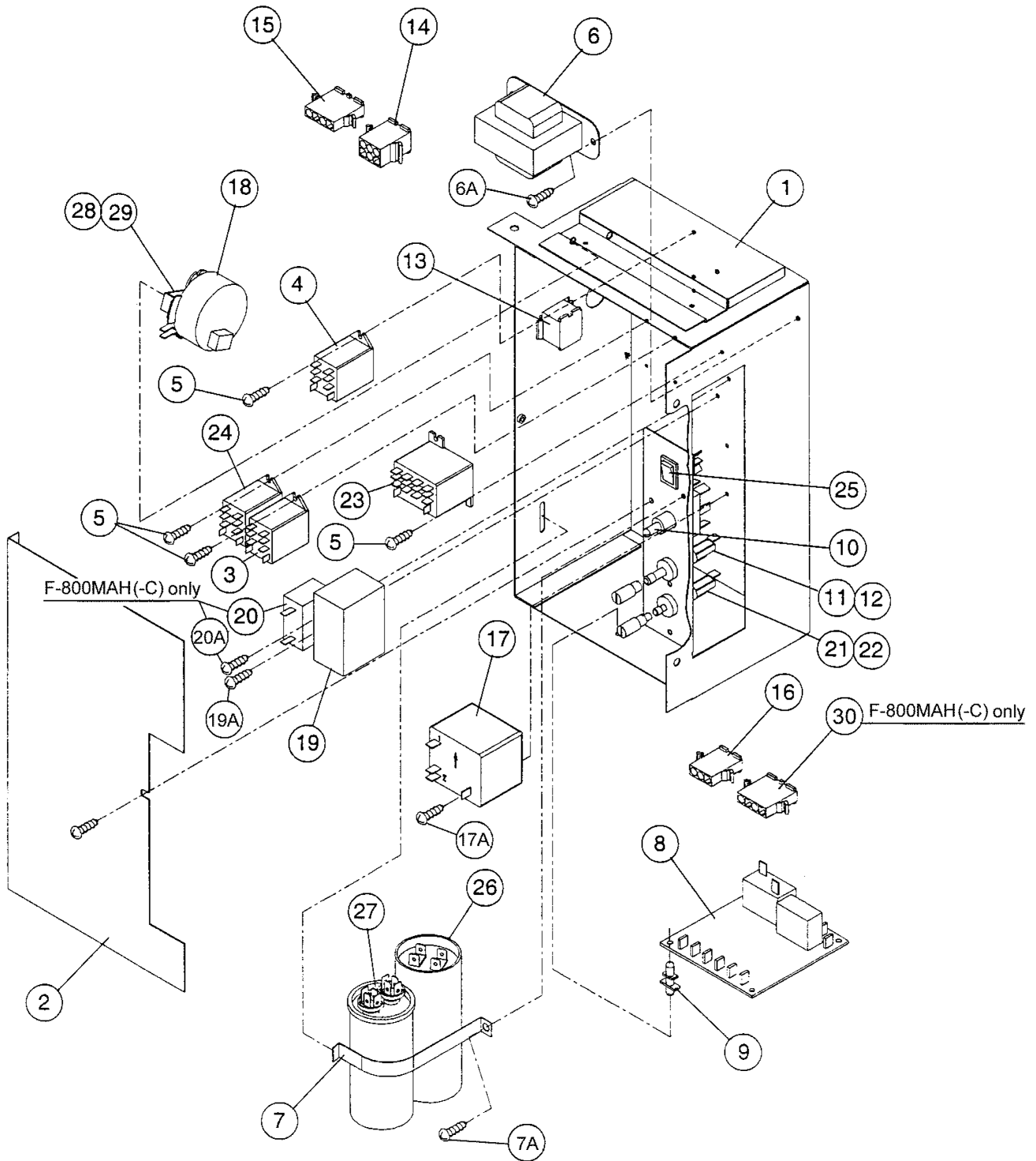

MODEL: F-800MAH(-C) , MWH(-C) TITLE: E. CONTROL BOX ASSEMBLY								
INDEX NO.	DESCRIPTION	MATERIAL OR MODEL NUMBER	PART NUMBER	REQUIRED NUMBER				
				L-0				
1	CONTROL BOX	GS	2A0229G04	1				
2	COVER-CONTROL BOX	GS	3A0411-01	1				
2A	TRUSS HEAD SCREW	4X8	7C31-0408	1				
3	RELAY	LY-1F, AC120V	418271-03	1				
4	RELAY	LY-2F, AC24V	406132-03	1				
5	TAPPING SCREW	3X8	431415-01	8				
6	TRANSFORMER	BE1416225GEK 120/24V, 1A	4A0557-01	1				
6A	T2 SCREW	4X8	7P31-0408	2				
7	STRAP	GS	434580-05	x1				
		GS	4A2262-03	o1				
7A	T2 SCREW	4X8	7P31-0408	2				
8	TIMER BOARD	H2AA144C01	437305-01	1				
9	BOARD SUPPORT	CBLS37-N	4A0336-03	4				
10	TOGGLE SWITCH	7599K1	4A2332-01	1				
11	FUSE HOLDER	HTB921, 250V, 1A	4A0892-01	1				
12	FUSE	AGC-1, 250V, 1A	4A0893-01	1				
13	9P PLUG HOUSING	3191-09P	412832-02	1				
14	6P PLUG HOUSING	3191-06P	412832-03	1				
15	4P PLUG HOUSING	3191-04P	412832-05	1				
16	3P PLUG HOUSING	3191-03P	412832-06	1				
17	STARTER	3ARR3CT24S5	4A1107-13	1				
17A	T2 SCREW	4X8	7P31-0408	1				
18	TIMER	9816-2	4A0889-01	1				
19	CAPACITOR (GM)	12FD, 330VAC	4A0894-01	1				
19A	T2 SCREW	4X8	7P31-0408	1				
20	CAPACITOR (FM) [F-800MAH(-C) ONLY]	5MFD	443192-02	1				
20A	T2 SCREW [F-800MAH(-C) ONLY]	4X8	7P31-0408	1				
21	FUSE	GMD 1.5A	4A0893-04	1				
22	FUSE HOLDER	HTB92M	4A0892-02	1				
23	RELAY	LY-4F,AC24V	406133-04	1				

HA

MODEL: F-800MAH(-C), MWH(-C) TITLE: E. CONTROL BOX ASSEMBLY								
INDEX NO.	DESCRIPTION	MATERIAL OR MODEL NUMBER	PART NUMBER	REQUIRED NUMBER				
				L-0				
24	RELAY	LY1F-HSD, AC220/240V	418271-05	1				
25	ROCKER SWITCH	62111929-0-0-N	4A0558-01	1				
26	CAPACITOR – START	-	3A0076-12	1				
27	CAPACITOR	X386S(HG02)	439943-02	x1				
		-	3A2005-06	o1				
28	CONNECTOR	-	4A0899-02	1				
29	SCREW	32 x 3/8	4A0898-01	2				
30	4P PLUG HOUSING [F-800MAH(-C) ONLY]	3191-04P	412832-05	1				

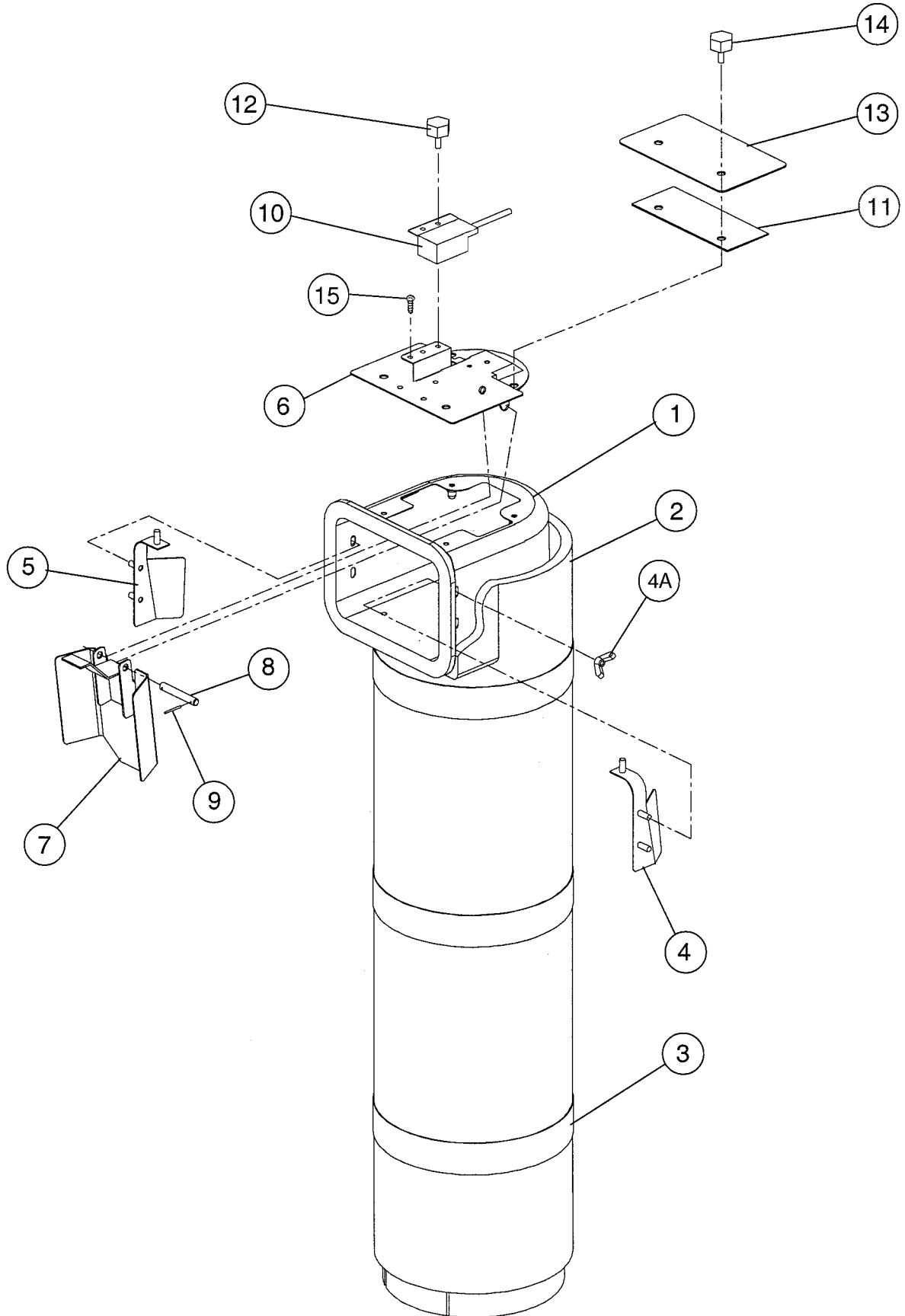

MODEL: F-800MAH(-C), MWH(-C)		TITLE: F. CHUTE ASSEMBLY						
INDEX NO.	DESCRIPTION	MATERIAL OR MODEL NUMBER	PART NUMBER	REQUIRED NUMBER				
				L-0				
1	CHUTE	PE	2A1057-01	1				
2	INSULATION-CHUTE	PE FOAM	213304-02	1				
3	TIE	PA	436531G01	3				
4	BAFFLE-CHUTE (A)	SS	3A0400G01	1				
4A	WING NUT	4, SS	7E12-0400	6				
5	BAFFLE-CHUTE (B)	SS	3A0399G01	1				
6	BIN CONTROL ASSEMBLY	SS	3A1744G01	1				
7	ACTUATOR	SS	436848G01	1				
8	SHAFT	SS	436851-01	1				
9	SNAP PIN	SS, SSP-5	715S-0005	2				
10	PROXIMITY SWITCH	RS-601	4A2033-01	1				
11	PACKING	EPDM	441217-01	1				
12	THUMBSCREW	ABS,SS	415949G04	2				
13	PLATE	SS	4A2039-01	1				
14	THUMBSCREW	ABS,SS	415949G09	2				
15	TRUSS HEAD SCREW	4X8, SS	7C32-0408	1				

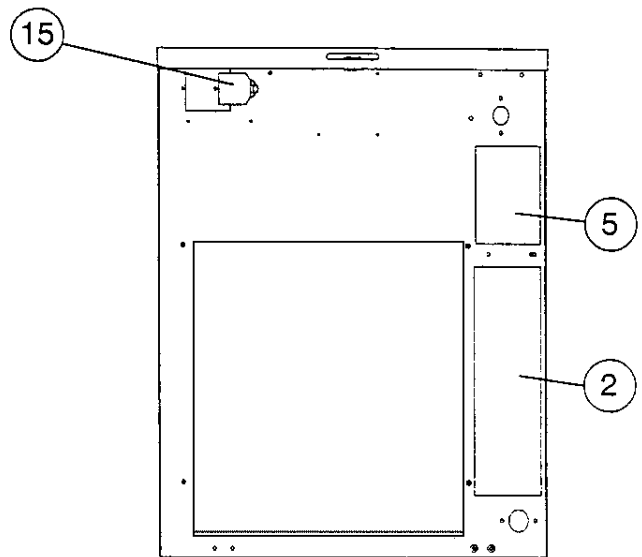
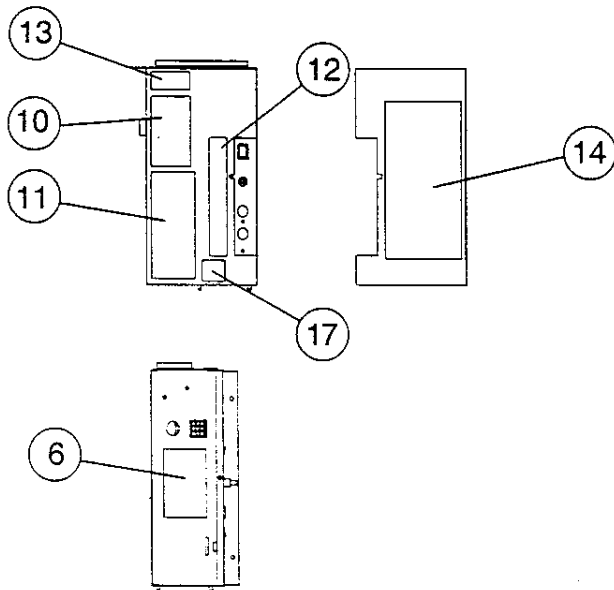
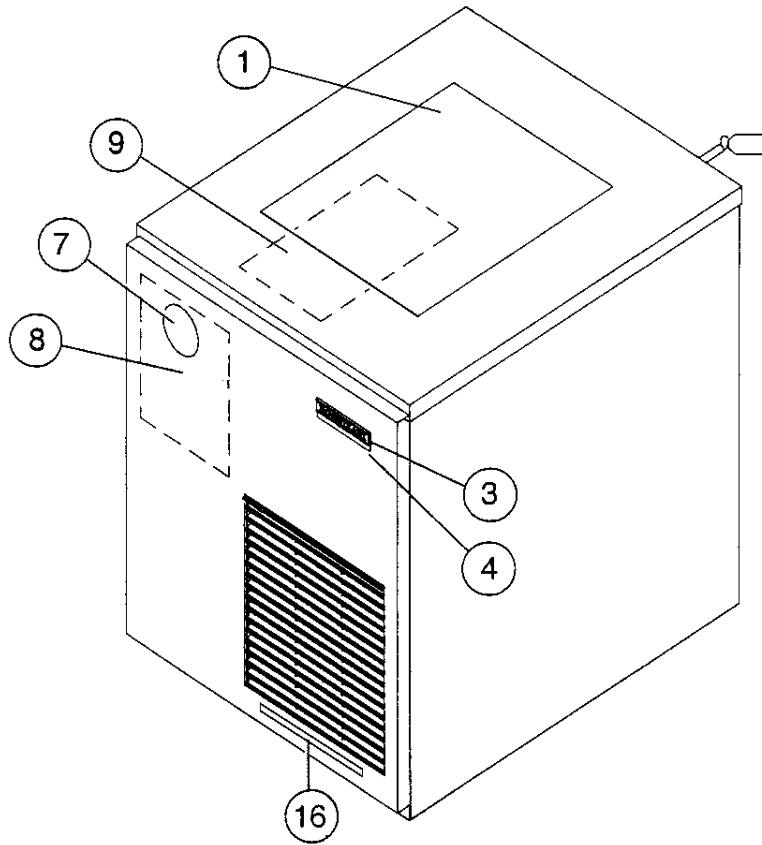

MODEL: F-800MAH		TITLE: G. LABEL LOCATION						
INDEX NO.	DESCRIPTION	MATERIAL OR MODEL NUMBER	PART NUMBER	REQUIRED NUMBER				
				L-0				
1	INSTRUCTION SHEET	PAPER	2A1054-01	1				
2	INSTRUCTION SHEET	PAPER	433523-01	1				
3	EMBLEM	PETP FILM	4A0560-01	1				
4	MODEL NUMBER LABEL	PETP FILM	4A2233-14	1				
5	NAMEPLATE	PES FILM	3A1835-01	1				
6	RATING LABEL	PES FILM	3A1836-01	1				
7	LABEL-PENGUIN-HA-R	PETP FILM	456246-01	1				
8	INSTRUCTION LABEL	PVC FILM	326371-01	1				
9	LABEL-CLEANING	PVC FILM	326370-01	1				
10	CAUTION LABEL (E)	PVC FILM	439145-01	1				
11	CAUTION LABEL (H)	PVC FILM	439148-01	1				
12	CONTROL LABEL	PVC FILM	4A1613-01	1				
13	LABEL-R404A	-	4A0960-01	1				
14	WIRING LABEL	PVC FILM	2A1703-01	1				
15	TAG-WARNING: ELECTRICAL CONNECTION	PAPER	435005-01	1				
16	LABEL-AIR FILTER	PETP FILM	426177-01	1				
17	LABEL (GM) - FUSE	PVC FILM	4A1614-01	1				

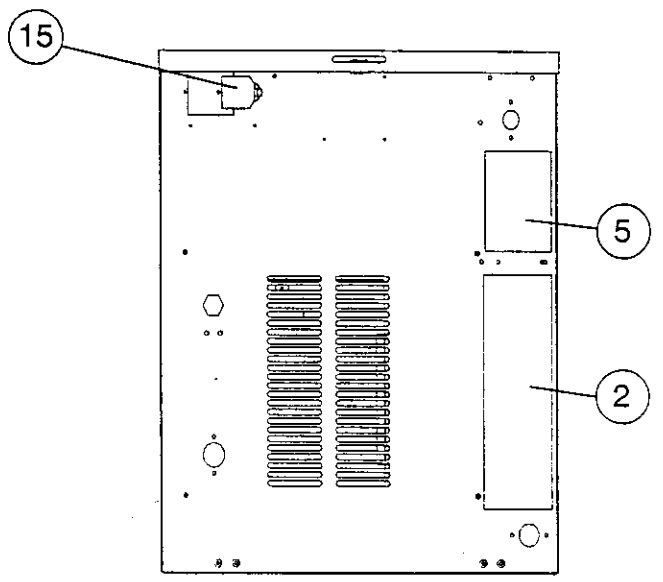
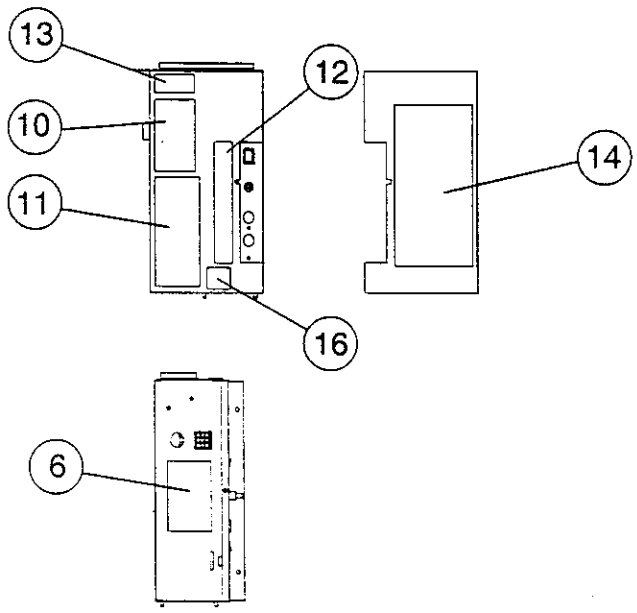
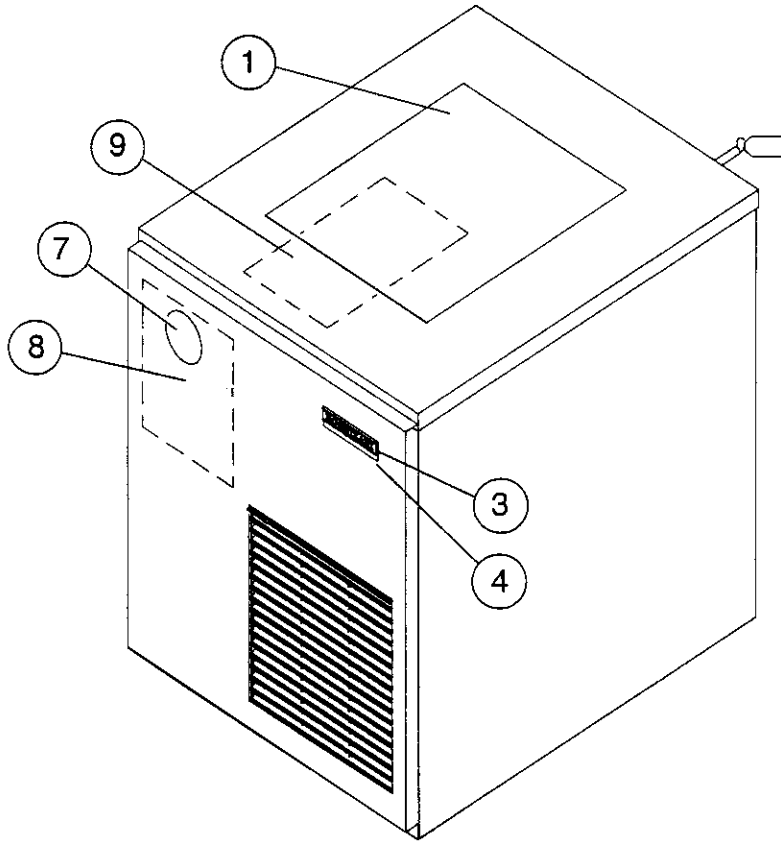

MODEL: F-800MWH		TITLE: G. LABEL LOCATION						
INDEX NO.	DESCRIPTION	MATERIAL OR MODEL NUMBER	PART NUMBER	REQUIRED NUMBER				
				L-0				
1	INSTRUCTION SHEET	PAPER	2A1054-01	1				
2	INSTRUCTION SHEET	PAPER	433523-01	1				
3	EMBLEM	PETP FILM	4A0560-01	1				
4	MODEL NUMBER LABEL	PETP FILM	4A2233-16	1				
5	NAMEPLATE	PES FILM	3A1835-03	1				
6	RATING LABEL	PES FILM	3A1836-03	1				
7	LABEL-PENGUIN-HA-R	PETP FILM	456246-01	1				
8	INSTRUCTION LABEL	PVC FILM	326371-01	1				
9	LABEL-CLEANING	PVC FILM	326370-01	1				
10	CAUTION LABEL (E)	PVC FILM	439145-01	1				
11	CAUTION LABEL (H)	PVC FILM	439148-01	1				
12	CONTROL LABEL	PVC FILM	4A1613-01	1				
13	LABEL-R404A	PES FILM	4A0960-01	1				
14	WIRING LABEL	PVC FILM	2A1703-01	1				
15	TAG-WARNING: ELECTRICAL CONNECTION	PAPER	435005-01	1				
16	LABEL (GM) - FUSE	PVC FILM	4A1614-01	1				

