



Reliability is a  
beautiful thing™

# **HOSHIZAKI®**

## **REACH-INS**

### **SafeTemp® Models**

**FH1-AAC(-HD)**

**FH2-AAC(-HD)**

## **PARTS LIST**

ITEM #: 71184  
ISSUED: March 8, 1999  
REVISED: June 27, 2005

# CONTENTS

|                                       |    |
|---------------------------------------|----|
| Material Abbreviations .....          | 4  |
| Auxiliary Codes.....                  | 5  |
| Note About Ordering Parts .....       | 6  |
| A. Reach-In.....                      | 7  |
| FH1-AAC(-HD) .....                    | 7  |
| FH2-AAC(-HD) .....                    | 9  |
| B. Refrigeration Assembly .....       | 11 |
| FH1-AAC(-HD) .....                    | 11 |
| FH2-AAC(-HD) .....                    | 13 |
| C. Panel-Front Hinged Assembly.....   | 15 |
| FH1-AAC(-HD), FH2-AAC(-HD) .....      | 15 |
| D. Body-Final .....                   | 16 |
| FH1-AAC .....                         | 16 |
| FH1-AAC-HD.....                       | 18 |
| FH2-AAC .....                         | 20 |
| FH2-AAC-HD.....                       | 22 |
| E. Control Box Assembly .....         | 24 |
| FH1-AAC(-HD), FH2-AAC(-HD) .....      | 24 |
| F. Fan-Evaporator Assembly .....      | 27 |
| FH1-AAC(-HD) .....                    | 27 |
| FH2-AAC(-HD) .....                    | 29 |
| G. Evaporator Assembly .....          | 30 |
| FH1-AAC(-HD) .....                    | 30 |
| FH2-AAC(-HD) .....                    | 32 |
| H. Condenser Assembly .....           | 34 |
| FH1-AAC(-HD) .....                    | 34 |
| FH2-AAC(-HD) .....                    | 36 |
| J. Body-Prefinal .....                | 37 |
| FH1-AAC(-HD) .....                    | 37 |
| FH2-AAC(-HD) .....                    | 39 |
| K. Door-Right.....                    | 41 |
| FH1-AAC, FH2-AAC.....                 | 41 |
| L. Door-Left.....                     | 42 |
| FH2-AAC .....                         | 42 |
| M. Door-Half (UR).....                | 43 |
| FH1-AAC-HD, FH2-AAC-HD .....          | 43 |
| N. Door-Half (LR).....                | 44 |
| FH1-AAC-HD, FH2-AAC-HD .....          | 44 |
| P. Door-Half (UL).....                | 45 |
| FH2-AAC-HD.....                       | 45 |
| Q. Door-Half (LL) .....               | 46 |
| FH2-AAC-HD.....                       | 46 |
| R. Distributor-Air Top Assembly ..... | 47 |
| FH1-AAC(-HD) .....                    | 47 |

|                                  |    |
|----------------------------------|----|
| S. Mullion-Horizontal.....       | 48 |
| FH1-AAC-HD.....                  | 48 |
| T. Mullion-Vertical.....         | 49 |
| FH2-AAC.....                     | 49 |
| U. Mullion-Cross .....           | 51 |
| FH2-AAC-HD.....                  | 51 |
| V. Label Location .....          | 53 |
| FH1-AAC(-HD) .....               | 53 |
| FH2-AAC(-HD) .....               | 54 |
| W. Literature & Packaging .....  | 55 |
| FH1-AAC(-HD), FH2-AAC(-HD) ..... | 55 |

## Material Abbreviations

### ALUMINUM

AL = Aluminum

### COPPER

CU = Copper

### PLASTIC

ABS = Acrylonitrile -butadiene - styrene  
AC = Polyacetal  
EVA = Ethylene vinyl acetate  
PA = Polyamide = Nylon  
PC = Polycarbonate  
PE = Polyethylene  
PES = Polyester  
PETP = Polyethylene terephthalate = Tetlon  
PP = Polypropylene  
PS = Polystyrene  
PTFE = Polytetrafluoroethylene = Teflon  
PUR = Polyurethane  
PVC = Polyvinyl chloride

### RUBBER

VN = Vinyl Nitrile  
EPDM = EP rubber  
NBR = Nitrile butadiene rubber  
NR = Natural rubber  
NP = Neoprene  
SI.R = Silicone rubber  
SY.R = Synthetic rubber  
EPH = Epichlorohydrin

### STEEL

GS = Galvanized steel  
SS = Stainless steel  
PS = Plated steel  
PAS = Primed steel

### AUXILIARY CODE

K-5

TT Designates the year. "K" indicates the year 2000. Years progress or regress in alphabetical order.  
"J" is 1999, "L" is 2001, "M" is 2002, and so on. The letters "I" and "O" were skipped.  
Designates significant part changes within the same year for this model. Base is 5 (0 for codes L-0 and earlier) and this number advances for each change.

Example: P-6

TT "P" indicates 2004.  
"6" indicates the first significant part change for 2004.

## Auxiliary Codes

**FH1-AAC**

|     |               |
|-----|---------------|
| K-0 | October 2000  |
| L-5 | March 2001    |
| M-5 | January 2002  |
| M-6 | February 2002 |
| M-7 | July 2002     |
| N-5 | December 2002 |
| N-6 | January 2003  |
| P-5 | December 2003 |
| P-6 | March 2004    |
| P-7 | October 2004  |
| P-8 | November 2004 |
| Q-5 | December 2004 |
| Q-6 | June 2005     |

**FH1-AAC-HD**

|     |               |
|-----|---------------|
| K-0 | October 2000  |
| L-0 | November 2000 |
| L-5 | March 2001    |
| M-5 | January 2002  |
| M-6 | March 2002    |
| M-7 | July 2002     |
| N-6 | January 2003  |
| P-5 | February 2004 |
| P-6 | March 2004    |
| Q-5 | December 2004 |
| Q-6 | June 2005     |

**FH2-AAC**

|     |               |
|-----|---------------|
| L-5 | February 2001 |
| M-5 | January 2002  |
| M-6 | March 2002    |
| M-7 | July 2002     |
| M-8 | August 2002   |
| N-5 | December 2002 |
| N-6 | January 2003  |
| P-5 | December 2003 |
| P-6 | August 2004   |
| P-7 | November 2004 |
| Q-5 | December 2004 |
| Q-6 | June 2005     |

## **Auxiliary Codes**

### **FH2-AAC-HD**

|     |               |
|-----|---------------|
| K-0 | August 2000   |
| L-5 | July 2001     |
| M-6 | March 2002    |
| N-6 | February 2003 |
| P-5 | January 2004  |
| P-6 | August 2004   |
| P-7 | October 2004  |
| P-8 | November 2004 |
| Q-5 | December 2004 |
| Q-6 | June 2005     |

## **Note About Ordering Parts**

Most assemblies cannot be ordered as complete units; parts in the assemblies generally must be ordered separately.

**A. Reach-In**  
**FH1-AAC(-HD)**

K-0, L-0, L-5, M-5, M-6, M-7, N-5, N-6, P-5, P-6, P-7, P-8, Q-5, Q-6

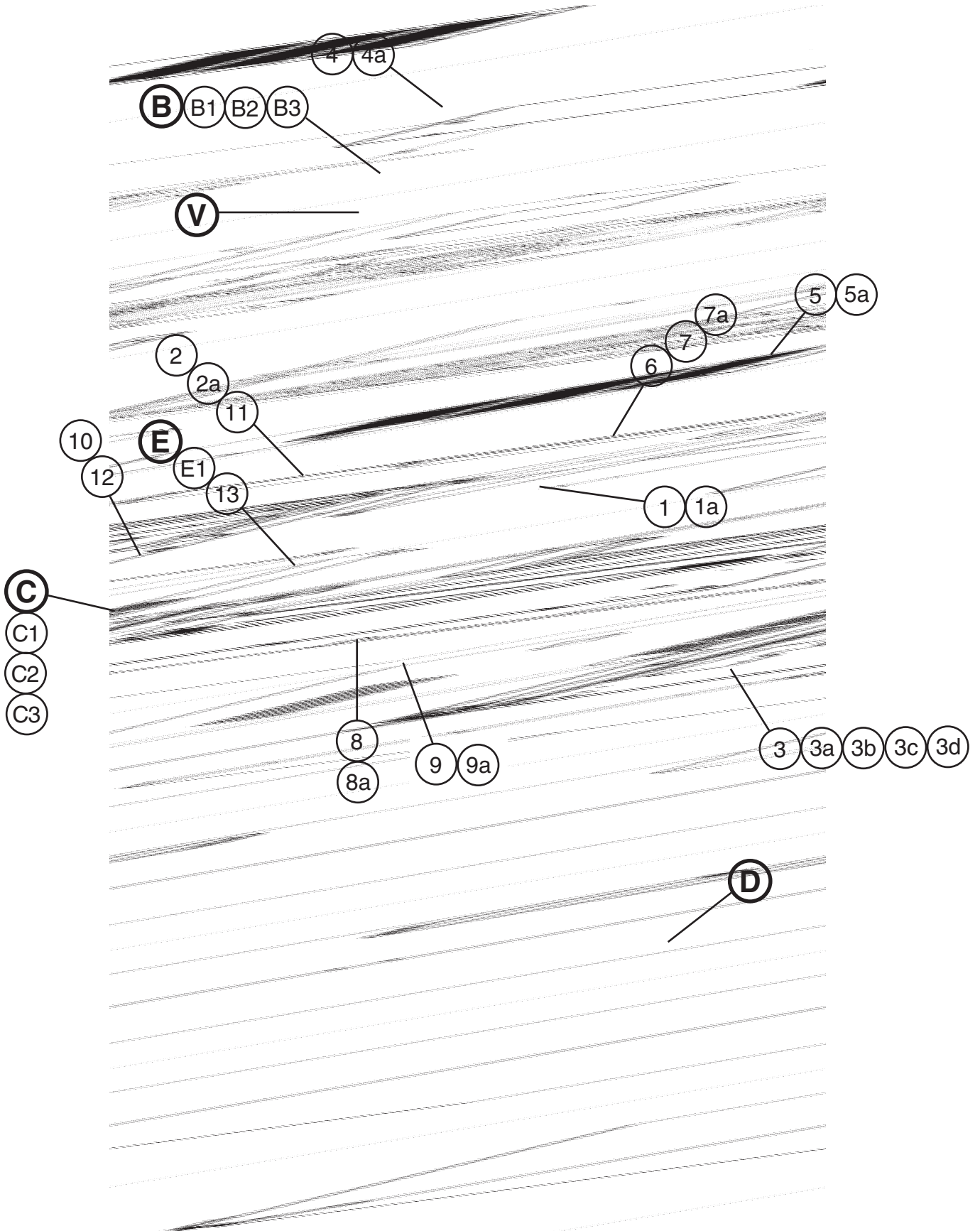

| Title: <b>A. Reach-In</b> Model: <b>FH1-AAC(-HD)</b> |                               |                          |             |                 |            |            |  |  |  |  |  |  |  |  |  |  |  |  |  |  |  |
|--|-------------------------------|--------------------------|-------------|-----------------|------------|------------|--|--|--|--|--|--|--|--|--|--|--|--|--|--|--|
| Index No.  | Description                   | Material or Model Number | Part Number | Required Number |            |            |  |  |  |  |  |  |  |  |  |  |  |  |  |  |  |
|  |                               |                          |             | K-0 to L-5      | M-5 to N-5 | N-6 to Q-6 |  |  |  |  |  |  |  |  |  |  |  |  |  |  |  |
| B  | Refrigeration System          | <b>Refrigerator</b>      | 1A0524A01   | 1               | 1          | 1          |  |  |  |  |  |  |  |  |  |  |  |  |  |  |  |
| B1   | Bolt Assembly                 | 8x45                     | 437889-01   | 5               | 5          | 5          |  |  |  |  |  |  |  |  |  |  |  |  |  |  |  |
| B2   | Truss Head Screw              | 5x25, SS                 | 7C32-0525   | 2               | 2          | 2          |  |  |  |  |  |  |  |  |  |  |  |  |  |  |  |
| B3   | Washer                        | 5                        | 7W22-0500   | 2               | 2          | 2          |  |  |  |  |  |  |  |  |  |  |  |  |  |  |  |
| C  | Panel – Front Hinged Assembly | -                        | 3A1670A01   | 1               | 1          | 1          |  |  |  |  |  |  |  |  |  |  |  |  |  |  |  |
| C1   | Clevis Pin                    | -                        | 8907-0102   | 2               | 2          | 2          |  |  |  |  |  |  |  |  |  |  |  |  |  |  |  |
| C2   | Cotter Pin                    | -                        | 8907-0103   | 2               | 2          | 2          |  |  |  |  |  |  |  |  |  |  |  |  |  |  |  |
| C3   | Flat Washer                   | -                        | 4A0655-03   | 2               | 2          | 2          |  |  |  |  |  |  |  |  |  |  |  |  |  |  |  |
| D  | Body – Final                  | <b>FH1-AAC</b>           | 1A0299A05   | 1               | 1          | 1          |  |  |  |  |  |  |  |  |  |  |  |  |  |  |  |
|  |                               | <b>FH1-AAC-HD</b>        | 1A0360A03   | 1               | 1          | 1          |  |  |  |  |  |  |  |  |  |  |  |  |  |  |  |
| E  | Control Box Assembly          | -                        | 2A1842A03   | 1               | 1          | 1          |  |  |  |  |  |  |  |  |  |  |  |  |  |  |  |
| E1   | T2 Screw                      | 4x8, SS                  | 7P32-0408   | 3               | 3          | 3          |  |  |  |  |  |  |  |  |  |  |  |  |  |  |  |
| V  | Label Location                | <b>FH1-AAC</b>           | 2A1042A09   | 1               | 1          | 1          |  |  |  |  |  |  |  |  |  |  |  |  |  |  |  |
|  |                               | <b>FH1-AAC-HD</b>        | 2A1042A08   | 1               | 1          | 1          |  |  |  |  |  |  |  |  |  |  |  |  |  |  |  |
| 1  | Gusset – Frame                | GS                       | 3A1520-01   | 1               | 1          | -          |  |  |  |  |  |  |  |  |  |  |  |  |  |  |  |
|  |                               |                          | 4A2845-01   |                 |            | 1          |  |  |  |  |  |  |  |  |  |  |  |  |  |  |  |
| 1a   | T2 Screw                      | 4x8, SS                  | 7P32-0408   | 4               | 4          | 4          |  |  |  |  |  |  |  |  |  |  |  |  |  |  |  |
| 2  | Frame – Side Top              | GS                       | 2A1803-01   | 2               | 2          | 2          |  |  |  |  |  |  |  |  |  |  |  |  |  |  |  |
| 2a   | Truss Head Screw              | 5x10, SS                 | 7C32-0510   | 8               | 8          | 8          |  |  |  |  |  |  |  |  |  |  |  |  |  |  |  |
| 3  | Panel – Side, Top             | AL                       | 2A1800-21   | 2               | 2          | 2          |  |  |  |  |  |  |  |  |  |  |  |  |  |  |  |
| 3a   | Truss Head Screw              | 5x10, SS                 | 7C32-0510   | 6               | 6          | 6          |  |  |  |  |  |  |  |  |  |  |  |  |  |  |  |
| 3b   | Taper Collar                  | SS                       | 4H0171-01   | 2               | 2          | 2          |  |  |  |  |  |  |  |  |  |  |  |  |  |  |  |
| 3c   | Screw Countersunk             | 5x20, SS                 | 7C42-0520   | 2               | 2          | 2          |  |  |  |  |  |  |  |  |  |  |  |  |  |  |  |
| 3d   | T2 Screw                      | 4x8, SS                  | 7P32-0408   | 4               | 4          | 4          |  |  |  |  |  |  |  |  |  |  |  |  |  |  |  |
| 4  | Cover UL Top                  | GS                       | 2A1304-01   | 1               | -          |            |  |  |  |  |  |  |  |  |  |  |  |  |  |  |  |
|  |                               |                          | 2A2373-01   |                 | 1          | -          |  |  |  |  |  |  |  |  |  |  |  |  |  |  |  |
|  |                               |                          | 2A2755-01   |                 |            | 1          |  |  |  |  |  |  |  |  |  |  |  |  |  |  |  |
| 4a   | T2 Screw                      | 4x8, SS                  | 7P32-0408   | 5               | 5          | 5          |  |  |  |  |  |  |  |  |  |  |  |  |  |  |  |
| 5  | Cover – UL, Rear              | GS                       | 2A0956-01   | 1               | 1          | -          |  |  |  |  |  |  |  |  |  |  |  |  |  |  |  |
|  |                               |                          | 2A2752-01   |                 |            | 1          |  |  |  |  |  |  |  |  |  |  |  |  |  |  |  |
| 5a   | T2 Screw                      | 4x8, SS                  | 7P32-0408   | 4               | 4          | 4          |  |  |  |  |  |  |  |  |  |  |  |  |  |  |  |
| 6  | Power Cord                    | -                        | 4A0520-01   | 1               | 1          | 1          |  |  |  |  |  |  |  |  |  |  |  |  |  |  |  |
| 7  | Wire Clamp                    | -                        | 4A0809-02   | 1               | 1          | 1          |  |  |  |  |  |  |  |  |  |  |  |  |  |  |  |
| 7a   | T2 Screw                      | 4x8, SS                  | 7P32-0408   | 1               | 1          | 1          |  |  |  |  |  |  |  |  |  |  |  |  |  |  |  |
| 8  | Cover – Connector Wire        | GS                       | 3A1678-01   | 1               | 1          | 1          |  |  |  |  |  |  |  |  |  |  |  |  |  |  |  |
| 8a   | T2 Screw                      | 4x8, SS                  | 7P32-0408   | 2               | 2          | 2          |  |  |  |  |  |  |  |  |  |  |  |  |  |  |  |
| 9  | Cover – Wire                  | GS                       | 3A1679-01   | 1               | 1          | 1          |  |  |  |  |  |  |  |  |  |  |  |  |  |  |  |
| 9a   | T2 Screw                      | 4x8, SS                  | 7P32-0408   | 3               | 3          | 3          |  |  |  |  |  |  |  |  |  |  |  |  |  |  |  |
| 10   | Bracket – Hinge               | GS                       | 4A2306-01   | 2               | 2          | 2          |  |  |  |  |  |  |  |  |  |  |  |  |  |  |  |
| 11   | Threaded Insert               | M5                       | 4A0407-01   | 4               | 4          | 4          |  |  |  |  |  |  |  |  |  |  |  |  |  |  |  |
| 12   | Spacer – Hinge                | PA                       | 4A2473-01   | 2               | 2          | 2          |  |  |  |  |  |  |  |  |  |  |  |  |  |  |  |
| 13   | Bracket – Control Box         | GS                       | 4A2467-01   | 1               | 1          | 1          |  |  |  |  |  |  |  |  |  |  |  |  |  |  |  |



**A. Reach-In**  
**FH2-AAC(-HD)**

K-0, L-5, M-5, M-6, M-7, M-8, N-5, N-6, P-5, P-6, P-7, P-8, Q-5, Q-6

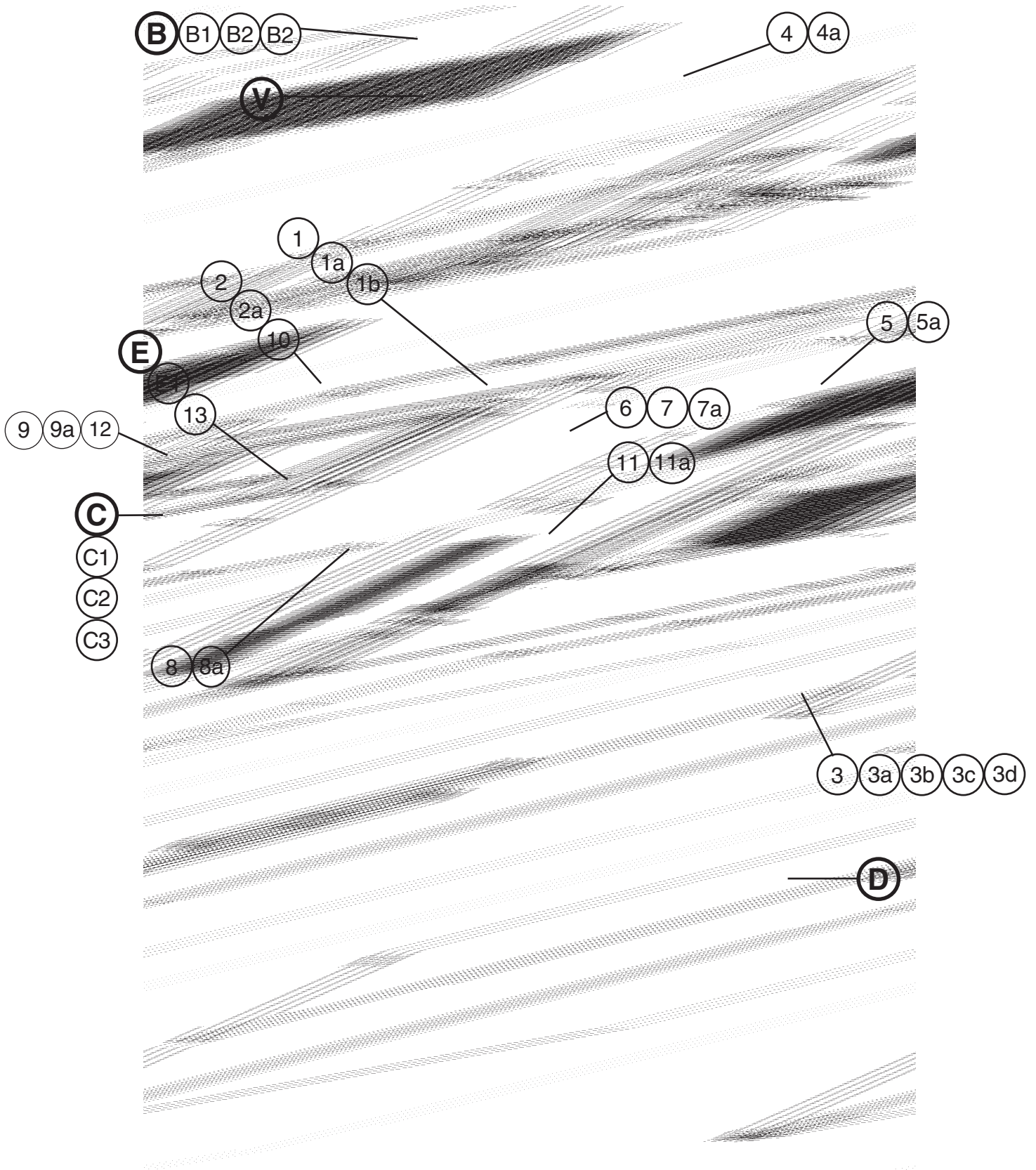

| Title: <b>A. Reach-In</b> Model: <b>FH2-AAC(-HD)</b> |                               |                          |             |                 |            |  |  |  |  |  |  |
|--|-------------------------------|--------------------------|-------------|-----------------|------------|--|--|--|--|--|--|
| Index No.  | Description                   | Material or Model Number | Part Number | Required Number |            |  |  |  |  |  |  |
|  |                               |                          |             | K-0 to N-5      | N-6 to Q-6 |  |  |  |  |  |  |
| B  | Refrigeration System          | -                        | 1A0255A02   | 1               | 1          |  |  |  |  |  |  |
| B1   | Bolt Assembly                 | 8x45                     | 437889-01   | 6               | 6          |  |  |  |  |  |  |
| B2   | Hex Bolt                      | 8x70                     | 7B01-0870   | 2               | 2          |  |  |  |  |  |  |
| B3   | Washer                        | 8                        | 7W22-0800   | 2               | 2          |  |  |  |  |  |  |
| C  | Panel – Front Hinged Assembly | -                        | 3A1670A02   | 1               | 1          |  |  |  |  |  |  |
| C1   | Clevis Pin                    | -                        | 8907-0102   | 2               | 2          |  |  |  |  |  |  |
| C2   | Cotter Pin                    | -                        | 8907-0103   | 2               | 2          |  |  |  |  |  |  |
| C3   | Flat Washer                   | -                        | 4A0655-03   | 2               | 2          |  |  |  |  |  |  |
| D  | Body – Final                  | <b>FH2-AAC</b>           | 2A1215A05   | 1               | 1          |  |  |  |  |  |  |
|  |                               | <b>FH2-AAC-HD</b>        | 1A0370A03   | 1               | 1          |  |  |  |  |  |  |
| E  | Control Box Assembly          | -                        | 2A1842A05   | 1               | 1          |  |  |  |  |  |  |
| E1   | T2 Screw                      | 4x8, SS                  | 7P32-0408   | 4               | 4          |  |  |  |  |  |  |
| V  | Label Location                | <b>FH2-AAC</b>           | 3A0603G09   | 1               | 1          |  |  |  |  |  |  |
|  |                               | <b>FH2-AAC-HD</b>        | 3A0603G08   | 1               | 1          |  |  |  |  |  |  |
| 1  | Gusset – Frame                | GS                       | 3A1520-01   | 1               | -          |  |  |  |  |  |  |
|  |                               | GS                       | 4A2845-01   |                 | 1          |  |  |  |  |  |  |
| 1a   | T2 Screw                      | 4x8, SS                  | 7P32-0408   | 2               | 2          |  |  |  |  |  |  |
| 1b   | Truss Head Screw              | 5x10, SS                 | 7C32-0510   | 2               | 2          |  |  |  |  |  |  |
| 2  | Frame – Side Top              | GS                       | 2A1803-01   | 2               | 2          |  |  |  |  |  |  |
| 2a   | Truss Head Screw              | 5x10                     | 7C32-0510   | 8               | 8          |  |  |  |  |  |  |
| 3  | Panel – Side, Top             | AL                       | 2A1800-21   | 2               | 2          |  |  |  |  |  |  |
| 3a   | Truss Head Screw              | 5x10, SS                 | 7C32-0510   | 6               | 6          |  |  |  |  |  |  |
| 3b   | Taper Collar                  | SS                       | 4H0171-01   | 2               | 2          |  |  |  |  |  |  |
| 3c   | Countersunk Screw             | 5x20, SS                 | 7C42-0520   | 2               | 2          |  |  |  |  |  |  |
| 3d   | T2 Screw                      | 4x8, SS                  | 7P32-0408   | 4               | 4          |  |  |  |  |  |  |
| 4  | Top UL Cover                  | GS                       | 2A1118-03   | 1               | 1          |  |  |  |  |  |  |
| 4a   | T2 Screw                      | 4x8, SS                  | 7P32-0408   | 5               | 5          |  |  |  |  |  |  |
| 5  | Rear UL Cover                 | GS                       | 2A1117-01   | 1               | 1          |  |  |  |  |  |  |
| 5a   | T2 Screw                      | 4x8, SS                  | 7P32-0408   | 5               | 5          |  |  |  |  |  |  |
| 6  | Power Cord Set                | -                        | 4A1543-01   | 1               | 1          |  |  |  |  |  |  |
| 7  | Wire Clamp                    | -                        | 4A0809-03   | 1               | 1          |  |  |  |  |  |  |
| 7a   | Truss Head Screw              | 5x8, SS                  | 7C32-0508   | 1               | 1          |  |  |  |  |  |  |
| 8  | Cover – Wire                  | GS                       | 2A1861-01   | 1               | 1          |  |  |  |  |  |  |
| 8a   | T2 Screw                      | 4x8                      | 7P32-0408   | 3               | 3          |  |  |  |  |  |  |
| 9  | Bracket – Hinge               | -                        | 4A2306-01   | 2               | 2          |  |  |  |  |  |  |
| 9a   | Truss Head Screw              | 4x8                      | 7C32-0408   | 2               | 2          |  |  |  |  |  |  |
| 10   | Threaded Insert               | M5                       | 4A0407-01   | 4               | 4          |  |  |  |  |  |  |
| 11   | Distributor – Air Top         | -                        | 1A0152-05   | 1               | 1          |  |  |  |  |  |  |
| 11a  | T2 Screw                      | 4x8, SS                  | 7P32-0408   | 7               | 7          |  |  |  |  |  |  |
| 12   | Spacer – Hinge                | PA                       | 4A2473-01   | 2               | 2          |  |  |  |  |  |  |
| 13   | Bracket – Control Box         | GS                       | 4A2467-01   | 1               | 1          |  |  |  |  |  |  |

## B. Refrigeration Assembly FH1-AAC(-HD)

K-0, L-0, L-5, M-5, M-6, M-7, N-5, N-6, P-5, P-6, P-7, P-8, Q-5, Q-6

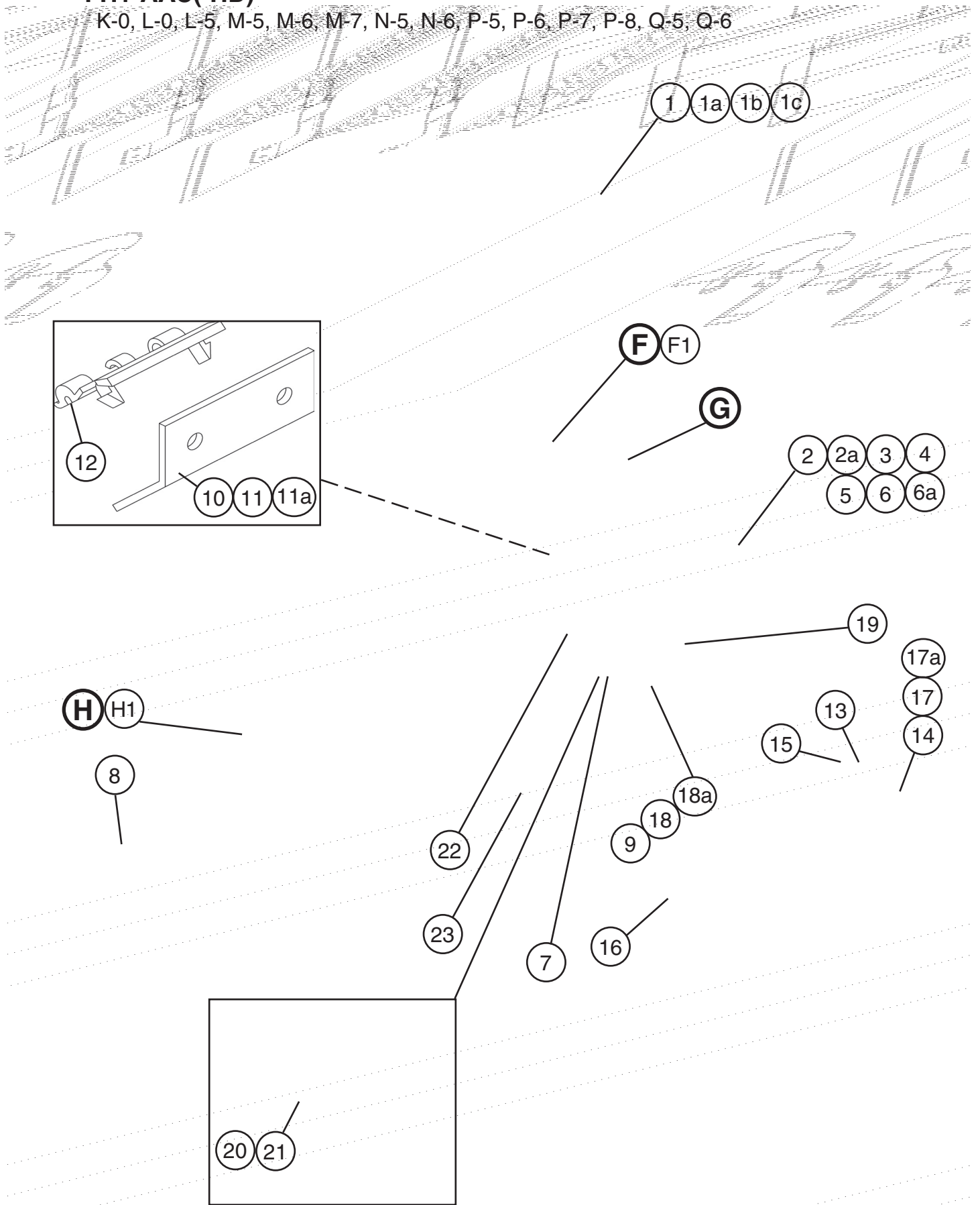

Title: **B. Refrigeration Assembly** Model: **FH1-AAC(-HD)**

| Index No. | Description               | Material or Model Number   | Part Number | Required Number  |            |     |         |            |  |  |  |  |  |  |  |  |  |  |  |  |  |
|-----------|---------------------------|--|-------------|--|------------|-----|---------|------------|--|--|--|--|--|--|--|--|--|--|--|--|--|
|           |                           |  |             | K-0 to M-5   | M-6 to N-5 | N-6 | P-5 P-6 | P-7 to Q-6 |  |  |  |  |  |  |  |  |  |  |  |  |  |
| F         | Fan – Evap Assembly       |  | HS-3545     | Non-interchangable part change at M-6. See Assembly F. | -          |     |         |            |  |  |  |  |  |  |  |  |  |  |  |  |  |
|           |                           |  | 2A2517A01   |  | 1          | 1   | -       |            |  |  |  |  |  |  |  |  |  |  |  |  |  |
|           |                           |  | 2A2517A02   |  |            |     | 1       | 1          |  |  |  |  |  |  |  |  |  |  |  |  |  |
| F1        | Truss Head Screw          | 4x12, SS   | 7C32-0412   | 4  | 4          | 4   | 4       | 4          |  |  |  |  |  |  |  |  |  |  |  |  |  |
| G         | Evaporator Assembly       | -  | 2A0981A03   | 1  | 1          | 1   | 1       | 1          |  |  |  |  |  |  |  |  |  |  |  |  |  |
| H         | Condenser Assembly        | -  | 3A0724A02   | 1  | 1          | -   |         |            |  |  |  |  |  |  |  |  |  |  |  |  |  |
|           |                           |  | 3A2610A02   |  |            | 1   | 1       | 1          |  |  |  |  |  |  |  |  |  |  |  |  |  |
| H1        | T2 Screw                  | 4x8, SS  | 7P32-0408   | 2  | 2          | 2   | 2       | 2          |  |  |  |  |  |  |  |  |  |  |  |  |  |
|           |                           |  |             |  |            |     |         |            |  |  |  |  |  |  |  |  |  |  |  |  |  |
| 1         | Cover – Evap Case (1 Sec) | -  | 2A0428G01   | 1  | 1          | -   |         |            |  |  |  |  |  |  |  |  |  |  |  |  |  |
|           |                           |  | 2A2726G01   |  |            | 1   | 1       | 1          |  |  |  |  |  |  |  |  |  |  |  |  |  |
| 1a        | Draw Latch                | 97-50-224-11   | 4A1710-01   | 4  | 4          | 4   | 4       | 4          |  |  |  |  |  |  |  |  |  |  |  |  |  |
| 1b        | Truss Head Screw          | 4x16, SS   | 7C32-0416   | 4  | 4          | 4   | 4       | 4          |  |  |  |  |  |  |  |  |  |  |  |  |  |
| 1c        | T2 Screw                  | 4x8, SS  | 7P32-0408   | 8  | 8          | 8   | 8       | 8          |  |  |  |  |  |  |  |  |  |  |  |  |  |
| 2         | Compressor                | -  | 2A0937-01   | 1  | 1          | 1   | 1       | 1          |  |  |  |  |  |  |  |  |  |  |  |  |  |
| 2a        | Protector                 | -  | 4A1860-02   | 1  | 1          | 1   | 1       | 1          |  |  |  |  |  |  |  |  |  |  |  |  |  |
| 3         | Sleeve                    | -  | 4A0449-01   | 4  | 4          | 4   | 4       | 4          |  |  |  |  |  |  |  |  |  |  |  |  |  |
| 4         | Grommet – Comp. Mount     | -  | 4A1305-01   | 4  | 4          | 4   | 4       | 4          |  |  |  |  |  |  |  |  |  |  |  |  |  |
| 5         | Flat Washer               | -  | 7W21-0800   | 4  | 4          | 4   | 4       | 4          |  |  |  |  |  |  |  |  |  |  |  |  |  |
| 6         | Hex Bolt                  | -  | 7B01-0845   | 4  | 4          | 4   | 4       | 4          |  |  |  |  |  |  |  |  |  |  |  |  |  |
| 6a        | Split Lock Washer         | -  | 7L21-0800   | 4  | 4          | 4   | 4       | 4          |  |  |  |  |  |  |  |  |  |  |  |  |  |
| 7         | Pipe – Evap Drain         | PVC  | 4A0831-01   | 1  | 1          | 1   | 1       | 1          |  |  |  |  |  |  |  |  |  |  |  |  |  |
| 8         | Filter – Cond             | -  | 3A0277-01   | 1  | 1          | 1   | 1       | 1          |  |  |  |  |  |  |  |  |  |  |  |  |  |
| 9         | Drier                     | SPORLAN CW-052-S   | 4A0924-01   | 1  | 1          | 1   | 1       | 1          |  |  |  |  |  |  |  |  |  |  |  |  |  |
| 10        | Thermistor – Cabinet      | Thermistor is to be replaced using kit HS-3540. Apply to all aux. codes. |             | -  | -          | -   | -       | -          |  |  |  |  |  |  |  |  |  |  |  |  |  |
| 11        | Thermistor Bracket (A)    | ABS  | 433964-01   | 1  | 1          | 1   | 1       | 1          |  |  |  |  |  |  |  |  |  |  |  |  |  |
| 11a       | Truss Head Screw          | 4x16, SS   | 7C32-0416   | 2  | 2          | 2   | 2       | 2          |  |  |  |  |  |  |  |  |  |  |  |  |  |
| 12        | Thermistor Bracket (B)    | ABS  | 433920-01   | 1  | 1          | 1   | 1       | 1          |  |  |  |  |  |  |  |  |  |  |  |  |  |
| 13        | Fitting – Drain Overflow  |  | 4A2182-01   | 1  | 1          | 1   | 1       | 1          |  |  |  |  |  |  |  |  |  |  |  |  |  |
| 14        | Gasket – Cond. Coil       | -  | 4A0455-03   | 1  | 1          | 1   | 1       | 1          |  |  |  |  |  |  |  |  |  |  |  |  |  |
| 15        | Rubber Gasket             | -  | 413854-03   | 1  | 1          | 1   | 1       | 1          |  |  |  |  |  |  |  |  |  |  |  |  |  |
| 16        | Pan – Evap. Drain         | -  | 2A0616-02   | 1  | 1          | -   |         |            |  |  |  |  |  |  |  |  |  |  |  |  |  |
|           |                           |  | 2A2760-01   |  |            | 1   | 1       | 1          |  |  |  |  |  |  |  |  |  |  |  |  |  |
| 17        | Strap – Condensate Coil   | -  | 3A0232-03   | 1  | 1          | 1   | 1       | 1          |  |  |  |  |  |  |  |  |  |  |  |  |  |
| 17a       | Truss Head Screw          | 5x12, SS   | 7C32-0512   | 2  | 2          | 2   | 2       | 2          |  |  |  |  |  |  |  |  |  |  |  |  |  |
| 18        | Drier Bracket             | -  | 4A0806-01   | 1  | 1          | 1   | 1       | 1          |  |  |  |  |  |  |  |  |  |  |  |  |  |
| 18a       | T2 Screw                  | 4x8, SS  | 7P32-0408   | 2  | 2          | 2   | 2       | 2          |  |  |  |  |  |  |  |  |  |  |  |  |  |
| 19        | Switch – Pressure         | -  | 4A2516-02   | 1  | 1          | 1   | 1       | 1          |  |  |  |  |  |  |  |  |  |  |  |  |  |
| 20        | Heater – Drain            | 10758 10w115v  | 4A2975-01   |  |            |     |         | 1          |  |  |  |  |  |  |  |  |  |  |  |  |  |
| 21        | Nylon Ties                | CV-200   | 8911-0200   |  |            |     |         | 1          |  |  |  |  |  |  |  |  |  |  |  |  |  |
| 22        | Pressure – Check Valve    |  | HS-3515     | 1  | -          |     |         |            |  |  |  |  |  |  |  |  |  |  |  |  |  |
| 23        | Coil – Condensate         |  | 3A1644-01   | 1  | 1          | 1   | 1       | 1          |  |  |  |  |  |  |  |  |  |  |  |  |  |

# B. Refrigeration Assembly FH2-AAC(-HD)

K-0, L-5, M-5, M-6, M-7, M-8, N-5, N-6, P-5, P-6, P-7, P-8, Q-5, Q-6

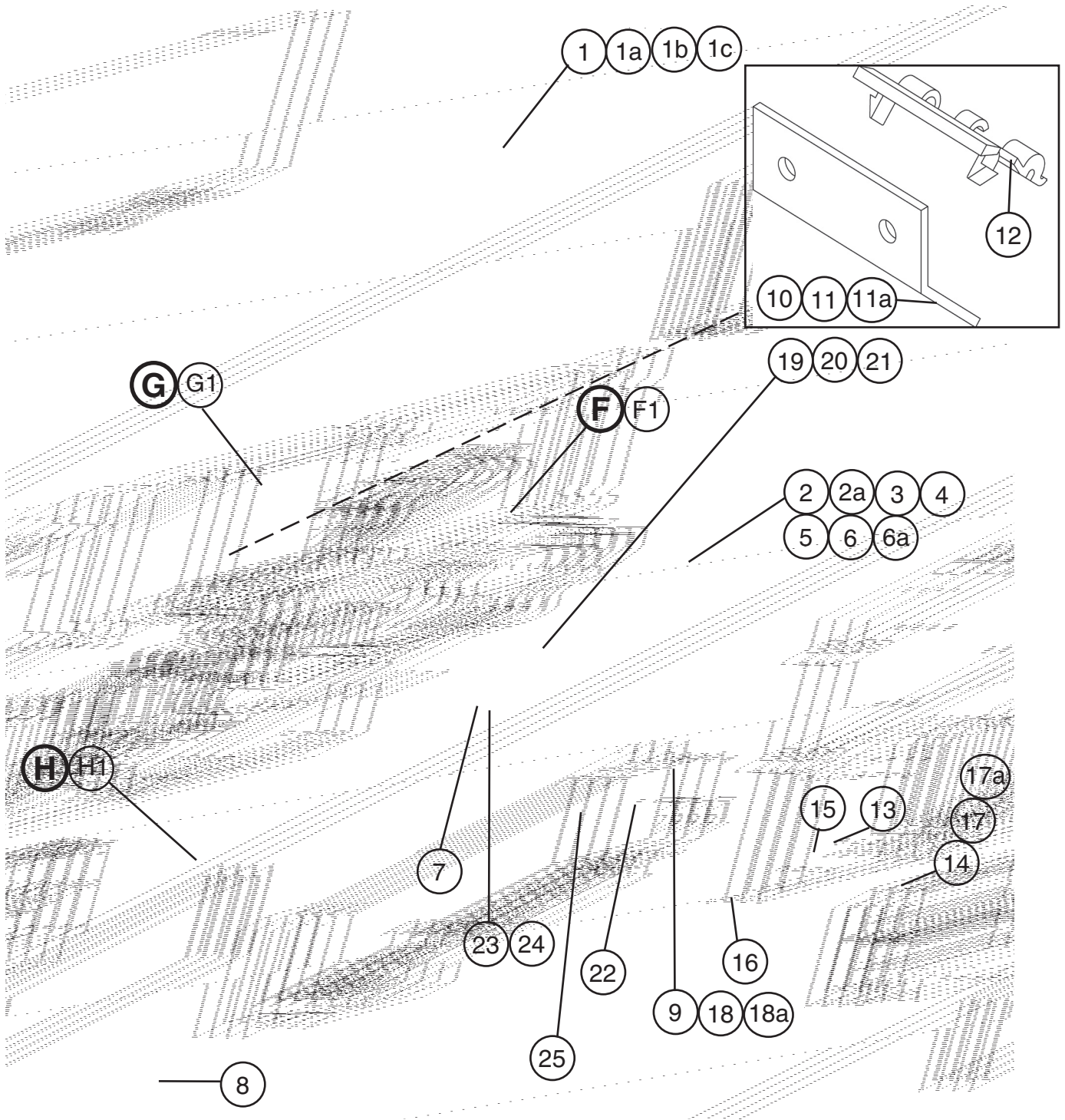

| Title: <b>B. Refrigeration Assembly</b> Model: <b>FH2-AAC(-HD)</b> |                           |  |             |                 |            |  |  |  |  |  |  |
|--|---------------------------|--|-------------|-----------------|------------|--|--|--|--|--|--|
| Index No.  | Description               | Material or Model Number   | Part Number | Required Number |            |  |  |  |  |  |  |
|  |                           |  |             | K-0 to P-5      | P-6 to Q-6 |  |  |  |  |  |  |
| F  | Evap Shroud Assm          | -  | 3A0263G01   | 1               | -          |  |  |  |  |  |  |
|  |                           |  | 3A0263G02   |                 | 1          |  |  |  |  |  |  |
| F1   | Truss Head Screw          | 4x16, SS   | 7C32-0416   | 2               | 2          |  |  |  |  |  |  |
| G  | Evaporator Assembly       | -  | 2A1015A02   | 1               | 1          |  |  |  |  |  |  |
| G1   | T2 Screw                  | 4x8, SS  | 7P32-0408   | 2               | 2          |  |  |  |  |  |  |
| H  | Condenser Assembly        | -  | 3A0585A01   | 1               | 1          |  |  |  |  |  |  |
| H1   | T2 Screw                  | 4x8, SS  | 7P32-0408   | 4               | 4          |  |  |  |  |  |  |
|  |                           |  |             |                 |            |  |  |  |  |  |  |
| 1  | Cover – Evap Case         | -  | 2A0245G01   | 1               | 1          |  |  |  |  |  |  |
| 1a   | Draw Latch                | 97-50-224-11   | 4A1710-01   | 4               | 4          |  |  |  |  |  |  |
| 1b   | Truss Head Screw          | 4x16, SS   | 7C32-0416   | 4               | 4          |  |  |  |  |  |  |
| 1c   | T2 Screw                  | 4x8, SS  | 7P32-0408   | 8               | 8          |  |  |  |  |  |  |
| 2  | Compressor                | -  | 4A1346-01   | 1               | 1          |  |  |  |  |  |  |
| 2a   | Protector                 | -  | 4A1877-05   | 1               | 1          |  |  |  |  |  |  |
| 3  | Spacer                    | -  | 434404-01   | 4               | 4          |  |  |  |  |  |  |
| 4  | Grommet – Comp. Mount     | -  | 434403-01   | 4               | 4          |  |  |  |  |  |  |
| 5  | Flat Washer               | -  | 7W21-0800   | 4               | 4          |  |  |  |  |  |  |
| 6  | Hex Bolt                  | -  | 7B01-0845   | 4               | 4          |  |  |  |  |  |  |
| 6a   | Split Lock Washer         | -  | 7L21-0800   | 4               | 4          |  |  |  |  |  |  |
| 7  | Pipe – Evap Drain         | PVC  | 3A0143-01   | 1               | 1          |  |  |  |  |  |  |
| 8  | Filter – Condenser        | -  | 3A0277-02   | 1               | 1          |  |  |  |  |  |  |
| 9  | Drier                     | SPORLAN CW-052-S   | 4A0924-01   | 1               | 1          |  |  |  |  |  |  |
| 10   | Thermistor – Cabinet      | Thermistor is to be replaced using kit HS-3540. Apply to all aux. codes. |             | -               | -          |  |  |  |  |  |  |
| 11   | Thermistor Bracket (A)    | ABS  | 433964-01   | 1               | 1          |  |  |  |  |  |  |
| 11a  | Truss Head Screw          | 4x16, SS   | 7C32-0416   | 2               | 2          |  |  |  |  |  |  |
| 12   | Thermistor Bracket (B)    | ABS  | 433920-01   | 1               | 1          |  |  |  |  |  |  |
| 13   | Fitting – Drain Overflow  | -  | 4A2182-01   | 1               | 1          |  |  |  |  |  |  |
| 14   | Gasket – Cond. Coil       | -  | 4A0455-01   | 1               | 1          |  |  |  |  |  |  |
| 15   | Rubber Gasket             | -  | 413854-03   | 1               | 1          |  |  |  |  |  |  |
| 16   | Pan – Evaporator Drain    | -  | 2A0200-02   | 1               | 1          |  |  |  |  |  |  |
| 17   | Strap – Condensate Coil   | -  | 3A0413-03   | 1               | 1          |  |  |  |  |  |  |
| 17a  | Truss Head Screw          | 5x10, SS   | 7C32-0510   | 1               | 1          |  |  |  |  |  |  |
| 18   | Drier Bracket             | -  | 4A0806-01   | 1               | 1          |  |  |  |  |  |  |
| 18a  | T2 Screw                  | 4x8, SS  | 7P32-0408   | 2               | 2          |  |  |  |  |  |  |
| 19   | Expansion Valve Cover (A) | -  | 3A0372-01   | 1               | 1          |  |  |  |  |  |  |
| 20   | Expansion Valve Cover (B) | -  | 3A0372-02   | 1               | 1          |  |  |  |  |  |  |
| 21   | Valve – Expansion         | -  | 4A0922-01   | 1               | 1          |  |  |  |  |  |  |
| 22   | Switch – Pressure         | -  | 4A2516-02   | 1               | 1          |  |  |  |  |  |  |
| 23   | Heater – Drain            | 10758 10w115v  | 4A2975-01   |                 | 1          |  |  |  |  |  |  |
| 24   | Nylon Ties                | CV-200   | 8911-0200   |                 | 1          |  |  |  |  |  |  |
| 25   | Coil – Condensate         |  | 2A1856-01   | 1               | 1          |  |  |  |  |  |  |

### C. Panel-Front Hinged Assembly FH1-AAC(-HD), FH2-AAC(-HD)

K-0, L-0, L-5, M-5, M-6, M-7, M-8, N-5, N-6, P-5, P-6, P-7, P-8, Q-5, Q-6

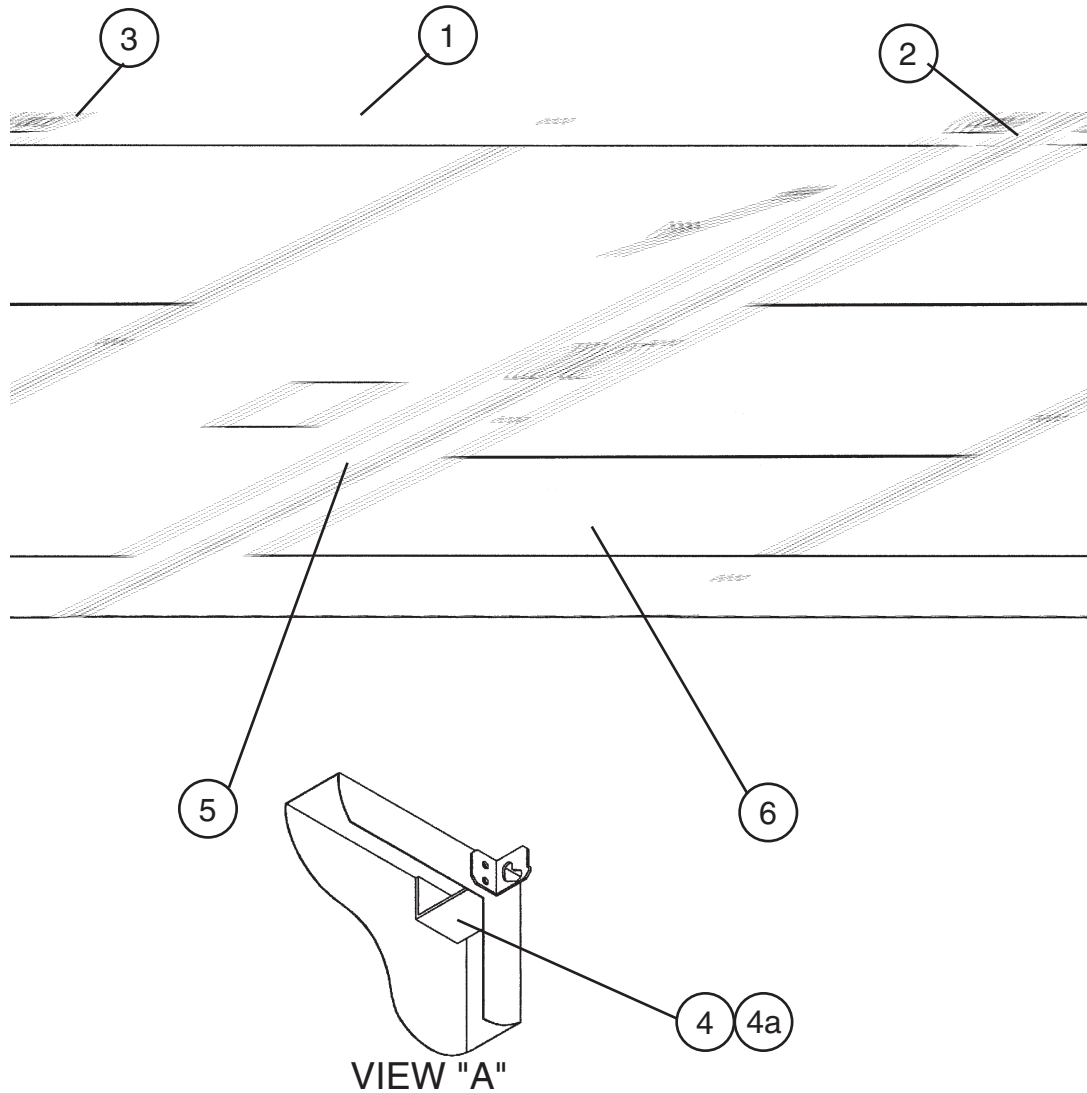

| Title: C. Panel-Front Hinged Assembly Model: FH1-AAC(-HD), FH2-AAC(-HD) |                         |                          |             |            | Required Number |  |  |  |  |  |  |  |  |
|---|-------------------------|--------------------------|-------------|------------|-----------------|--|--|--|--|--|--|--|--|
| Index No.   | Description             | Material or Model Number | Part Number | K-0 to Q-6 |                 |  |  |  |  |  |  |  |  |
| 1   | Panel – Front Hinged    | FH1-AAC(-HD)             | 2A1799-01   | 1          |                 |  |  |  |  |  |  |  |  |
|   |                         | FH2-AAC(-HD)             | 2A1799-02   | 1          |                 |  |  |  |  |  |  |  |  |
| 2   | Hinge – Front Panel (L) | GS                       | 4A2153-01   | 1          |                 |  |  |  |  |  |  |  |  |
| 3   | Hinge – Front Panel (R) | GS                       | 4A2154-01   | 1          |                 |  |  |  |  |  |  |  |  |
| 4   | Channel – Hinge         | GS                       | 4A2170-01   | 2          |                 |  |  |  |  |  |  |  |  |
| 4a  | Truss Head Screw        | 5x8, SS                  | 7C32-0508   | 4          |                 |  |  |  |  |  |  |  |  |
| 5   | Blind                   | FH1-AAC(-HD)             | 3A1763-01   | 1          |                 |  |  |  |  |  |  |  |  |
|   |                         | FH2-ACC(-HD)             | 3A1763-02   | 1          |                 |  |  |  |  |  |  |  |  |
| 6   | Support – Blind         | -                        | 4A2267-01   | 1          |                 |  |  |  |  |  |  |  |  |

**D. Body-Final**  
**FH1-AAC**

K-0, L-5, M-5, M-6, M-7, N-5, N-6, P-5, P-6, P-7, P-8, Q-5, Q-6

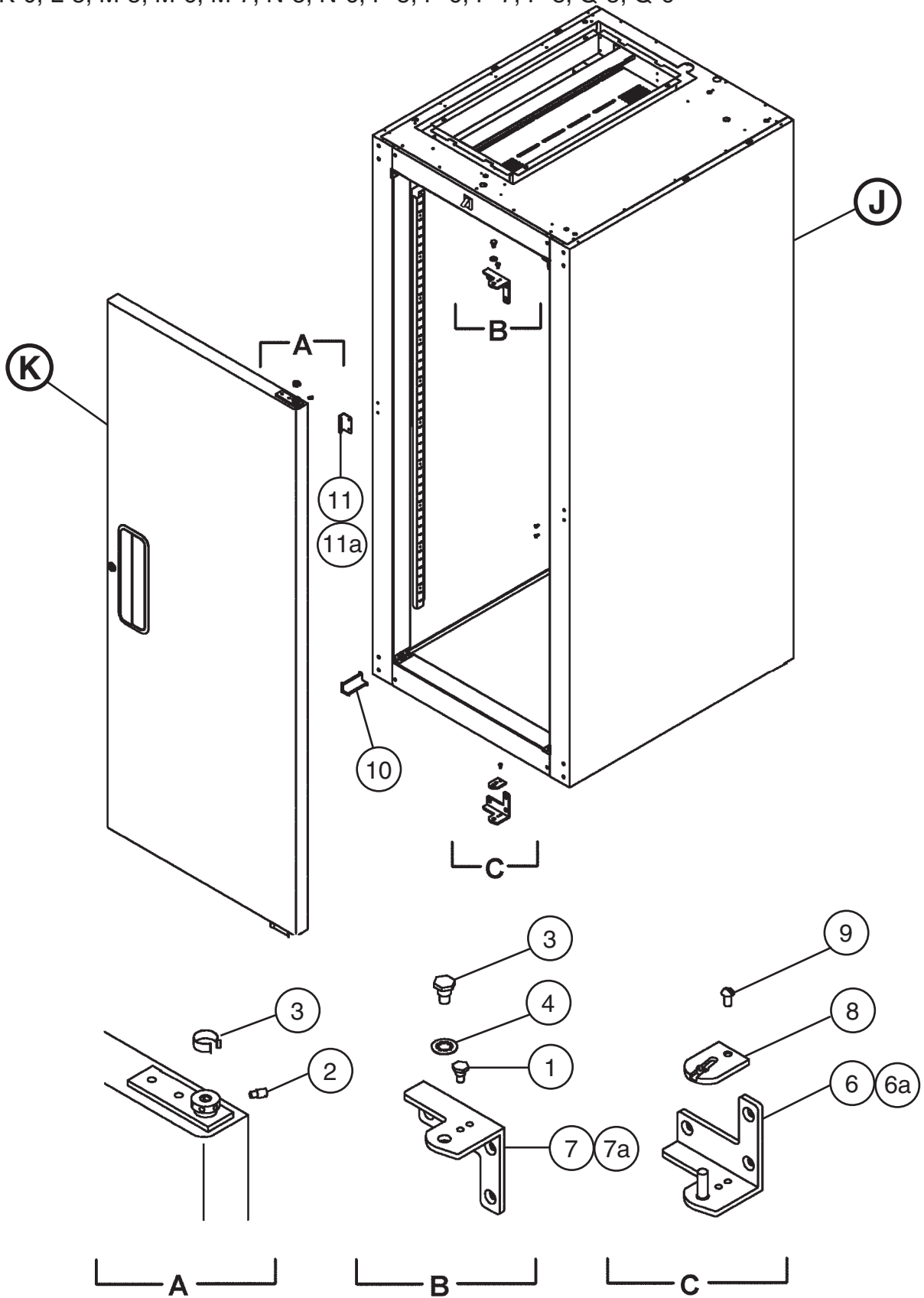



| Title: <b>D. Body Final</b> Model: <b>FH1-AAC</b> |                           |                          |             |                 |  |  |  |  |  |  |  |  |
|---|---------------------------|--------------------------|-------------|-----------------|--|--|--|--|--|--|--|--|
| Index No.   | Description               | Material or Model Number | Part Number | Required Number |  |  |  |  |  |  |  |  |
|   |                           |                          |             | K-0 to Q-6      |  |  |  |  |  |  |  |  |
| J   | Body – Prefinal           | -                        | 1A0298A04   | 1               |  |  |  |  |  |  |  |  |
| K   | Door – Right              | -                        | 1A0318A03   | 1               |  |  |  |  |  |  |  |  |
| 1   | Hinge – Stop Pin          | PS                       | 4A2180-01   | 1               |  |  |  |  |  |  |  |  |
| 2   | Hinge – Tension Screw     | PS                       | 4A0446-01   | 1               |  |  |  |  |  |  |  |  |
| 3   | Hinge – Bushing Cover     | SS                       | 4A0445-01   | 1               |  |  |  |  |  |  |  |  |
| 4   | Hinge – Lock Washer       | PS                       | 4A0553-01   | 1               |  |  |  |  |  |  |  |  |
| 5   | Hinge – Pivot Pin (Top)   | PS                       | 4A2179-01   | 1               |  |  |  |  |  |  |  |  |
| 6   | Bracket – Door Hinge (LR) | PS                       | 3A1626-01   | 1               |  |  |  |  |  |  |  |  |
| 6a  | Countersunk Screw         | 5x10, SS                 | 7C42-0510   | 3               |  |  |  |  |  |  |  |  |
| 7   | Bracket – Door Hinge (UR) | PS                       | 3A1580-01   | 1               |  |  |  |  |  |  |  |  |
| 7a  | Countersunk Screw         | 5x10, SS                 | 7C42-0510   | 3               |  |  |  |  |  |  |  |  |
| 8   | Hingestop Plate (R)       | PS                       | 4A0441-01   | 1               |  |  |  |  |  |  |  |  |
| 9   | Screw – Stop Plate        | PS                       | 4A0483-01   | 1               |  |  |  |  |  |  |  |  |
| 10  | Cover – Corner            | ABS                      | 3A1751-01   | 4               |  |  |  |  |  |  |  |  |
| 11  | Plate – Strike (Side)     | SS                       | 4A0470-01   | 1               |  |  |  |  |  |  |  |  |
| 11a   | T2 Screw                  | 4x8, SS                  | 7P32-0408   | 2               |  |  |  |  |  |  |  |  |

**D. Body-Final**  
**FH1-AAC-HD**

K-0, L-0, L-5, M-5, M-6, M-7, N-6, P-5, P-6, Q-5, Q-6

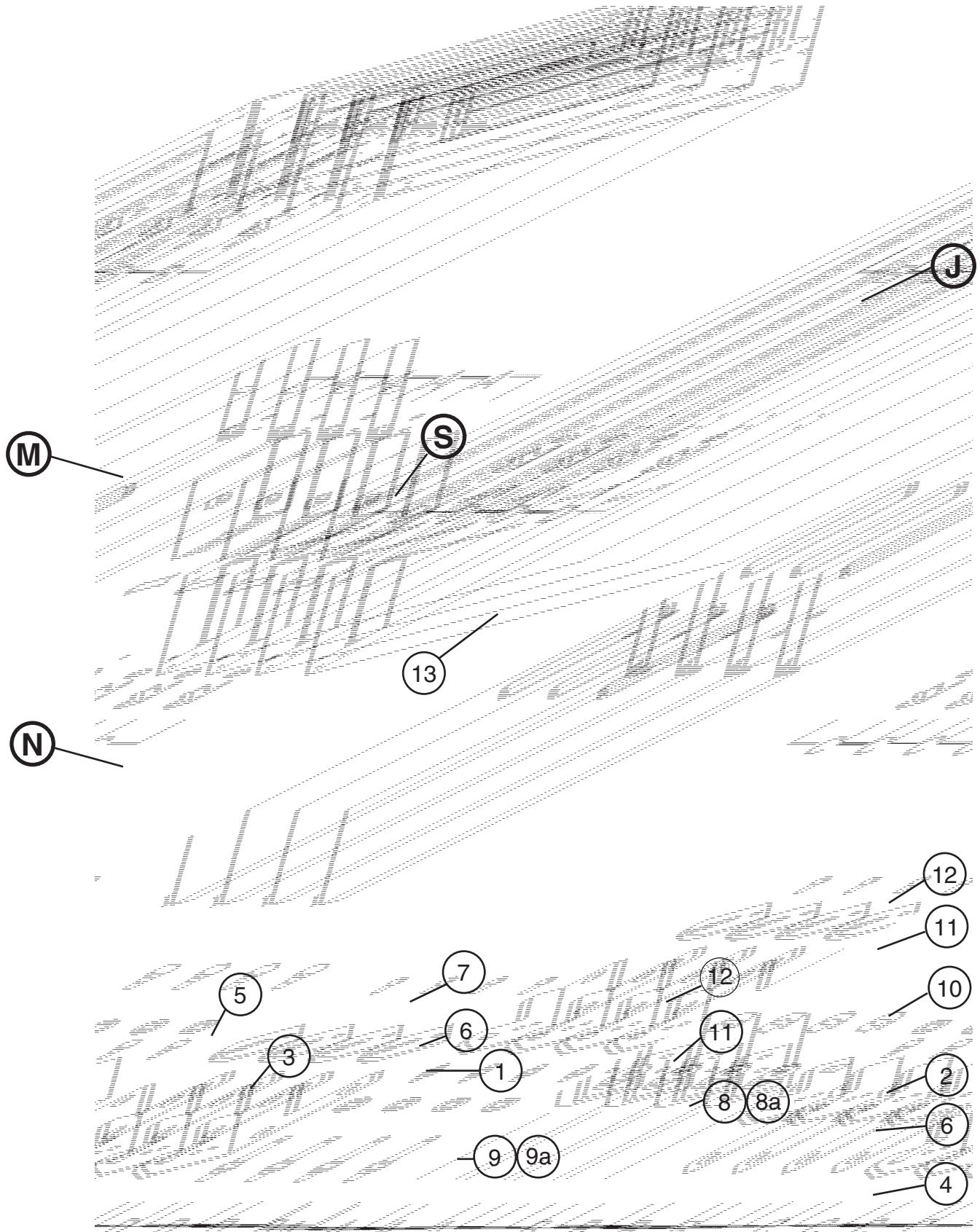

| Title: <b>D. Body-Final</b> Model: <b>FH1-AAC-HD</b> |                           |                          |             |                 |  |  |  |  |  |  |  |  |
|--|---------------------------|--------------------------|-------------|-----------------|--|--|--|--|--|--|--|--|
| Index No.  | Description               | Material or Model Number | Part Number | Required Number |  |  |  |  |  |  |  |  |
|  |                           |                          |             | K-0 to Q-6      |  |  |  |  |  |  |  |  |
| J  | Body – Prefinal           | -                        | 1A0354A03   | 1               |  |  |  |  |  |  |  |  |
| M  | Door – Half (UR)          | -                        | 1A0326A03   | 1               |  |  |  |  |  |  |  |  |
| N  | Door – Half (LR)          | -                        | 1A0324A03   | 1               |  |  |  |  |  |  |  |  |
| S  | Mullion – Horizontal      | -                        | 2A1323A03   | 1               |  |  |  |  |  |  |  |  |
| 1  | Hinge – Stop Pin          | PS                       | 4A2180-01   | 1               |  |  |  |  |  |  |  |  |
| 2  | Stop Pin                  | PS                       | 4A1734-01   | 1               |  |  |  |  |  |  |  |  |
| 3  | Hinge – Tension Screw     | SS                       | 4A0446-01   | 2               |  |  |  |  |  |  |  |  |
| 4  | Pivot Pin                 | PS                       | 4A1735-01   | 1               |  |  |  |  |  |  |  |  |
| 5  | Hinge – Bushing Cover     | PS                       | 4A0445-01   | 2               |  |  |  |  |  |  |  |  |
| 6  | Hinge – Lock Washer       | PS                       | 4A0553-01   | 2               |  |  |  |  |  |  |  |  |
| 7  | Hinge – Pivot Pin (Top)   | PS                       | 4A2179-01   | 1               |  |  |  |  |  |  |  |  |
| 8  | Bracket – Door Hinge (LR) | PS                       | 3A1626-01   | 1               |  |  |  |  |  |  |  |  |
| 8a   | Countersunk Screw         | 5×10, SS                 | 7C42-0510   | 3               |  |  |  |  |  |  |  |  |
| 9  | Bracket – Door Hinge (UR) | PS                       | 3A1580-01   | 1               |  |  |  |  |  |  |  |  |
| 9a   | Countersunk Screw         | 5×10, SS                 | 7C42-0510   | 3               |  |  |  |  |  |  |  |  |
| 10   | Bracket – Door Hinge (UL) | PS                       | 3A1581-01   | 1               |  |  |  |  |  |  |  |  |
| 10a  | Truss Head Screw          | 5×10, SS                 | 7C32-0510   | 3               |  |  |  |  |  |  |  |  |
| 11   | Hinge – Stop Plate (R)    | PS                       | 4A0441-01   | 2               |  |  |  |  |  |  |  |  |
| 12   | Screw – Stop Plate        | PS                       | 4A0483-01   | 2               |  |  |  |  |  |  |  |  |
| 13   | Cover – Corner            | ABS                      | 3A1751-01   | 8               |  |  |  |  |  |  |  |  |

**D. Body-Final**  
**FH2-AAC**

L-5, M-5, M-6, M-7, M-8, N-5, N-6, P-5, P-6, P-7, Q-5, Q-6

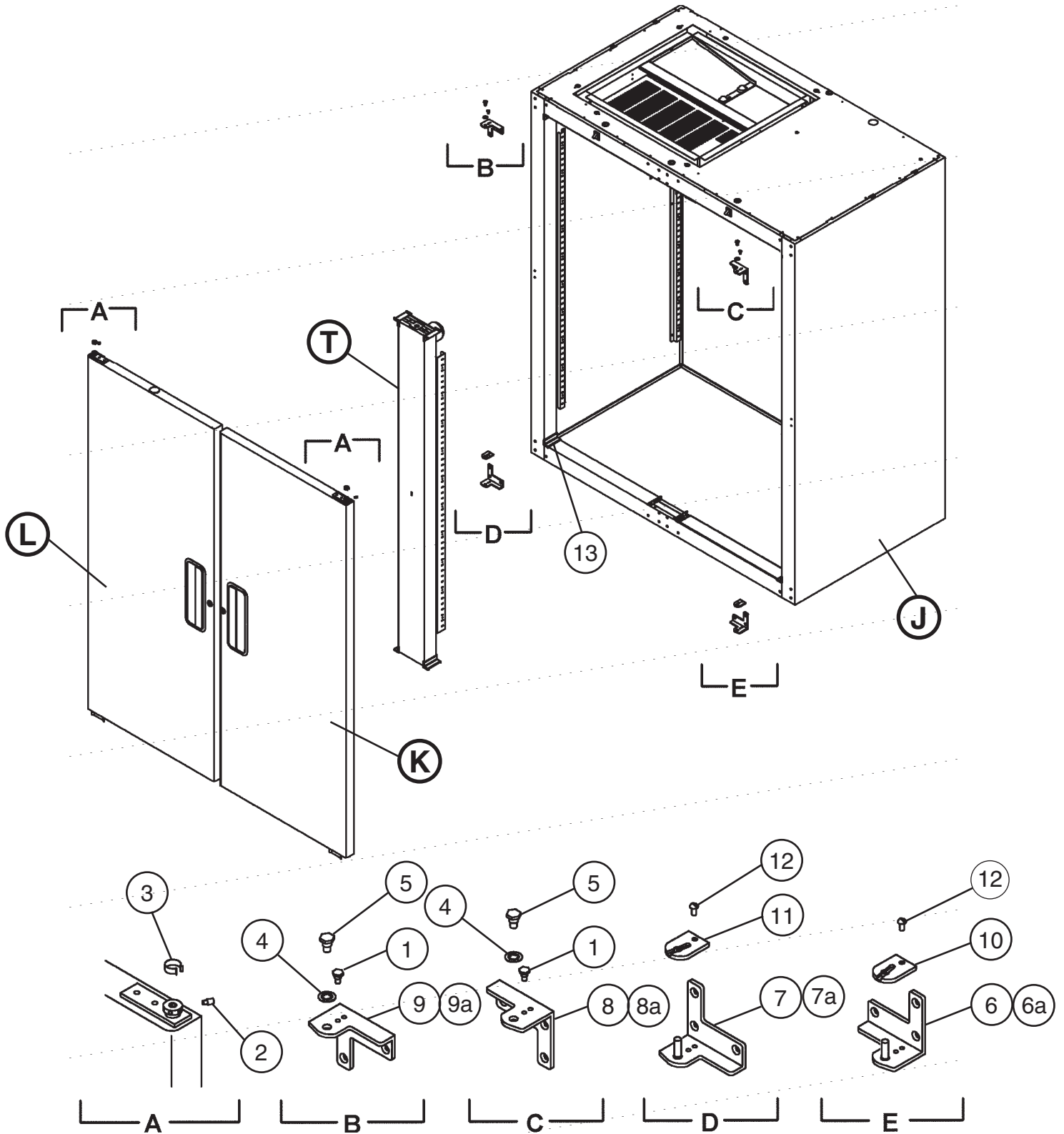

| Title: <b>D. Body Final</b> Model: <b>FH2-AAC</b> |                           |                          |             |                 |  |  |  |  |  |  |  |  |  |
|---|---------------------------|--------------------------|-------------|-----------------|--|--|--|--|--|--|--|--|--|
| Index No.   | Description               | Material or Model Number | Part Number | Required Number |  |  |  |  |  |  |  |  |  |
|   |                           |                          |             | L-5 to Q-6      |  |  |  |  |  |  |  |  |  |
| J   | Body – Prefinal           | -                        | 2A1207A05   | 1               |  |  |  |  |  |  |  |  |  |
| K   | Door – Right              | -                        | 1A0318A03   | 1               |  |  |  |  |  |  |  |  |  |
| L   | Door – Left               | -                        | 1A0318A04   | 1               |  |  |  |  |  |  |  |  |  |
| T   | Mullion – Vertical        | -                        | 2A1289A04   | 1               |  |  |  |  |  |  |  |  |  |
|   |                           |                          |             |                 |  |  |  |  |  |  |  |  |  |
| 1   | Hinge – Stop Pin          | PS                       | 4A2180-01   | 2               |  |  |  |  |  |  |  |  |  |
| 2   | Hinge – Tension Screw     | PS                       | 4A0446-01   | 2               |  |  |  |  |  |  |  |  |  |
| 3   | Hinge – Bushing Cover     | SS                       | 4A0445-01   | 2               |  |  |  |  |  |  |  |  |  |
| 4   | Hinge – Lock Washer       | PS                       | 4A0553-01   | 2               |  |  |  |  |  |  |  |  |  |
| 5   | Hinge – Pivot Pin (Top)   | PS                       | 4A2179-01   | 2               |  |  |  |  |  |  |  |  |  |
| 6   | Bracket – Door Hinge (LR) | PS                       | 3A1626-01   | 1               |  |  |  |  |  |  |  |  |  |
| 6a  | Countersunk Screw         | 5x10, SS                 | 7C42-0510   | 3               |  |  |  |  |  |  |  |  |  |
| 7   | Bracket – Door Hinge (LL) | PS                       | 3A1627-01   | 1               |  |  |  |  |  |  |  |  |  |
| 7a  | Countersunk Screw         | 5x10, SS                 | 7C42-0510   | 3               |  |  |  |  |  |  |  |  |  |
| 8   | Bracket – Door Hinge (UR) | PS                       | 3A1580-01   | 1               |  |  |  |  |  |  |  |  |  |
| 8a  | Countersunk Screw         | 5x10, SS                 | 7C42-0510   | 3               |  |  |  |  |  |  |  |  |  |
| 9   | Bracket – Door Hinge (UL) | PS                       | 3A1581-01   | 1               |  |  |  |  |  |  |  |  |  |
| 9a  | Countersunk Screw         | 5x10, SS                 | 7C42-0510   | 3               |  |  |  |  |  |  |  |  |  |
| 10  | Hinge – Stop Plate (R)    | PS                       | 4A0441-01   | 1               |  |  |  |  |  |  |  |  |  |
| 11  | Hinge – Stop Plate (L)    | PS                       | 4A0441-02   | 1               |  |  |  |  |  |  |  |  |  |
| 12  | Screw – Stop Plate        | PS                       | 4A0483-01   | 2               |  |  |  |  |  |  |  |  |  |
| 13  | Cover – Corner            | ABS                      | 3A1751-01   | 8               |  |  |  |  |  |  |  |  |  |

# D. Body-Final FH2-AAC-HD

K-0, L-5, M-6, N-6, P-5, P-6, P-7, P-8, Q-5, Q-6

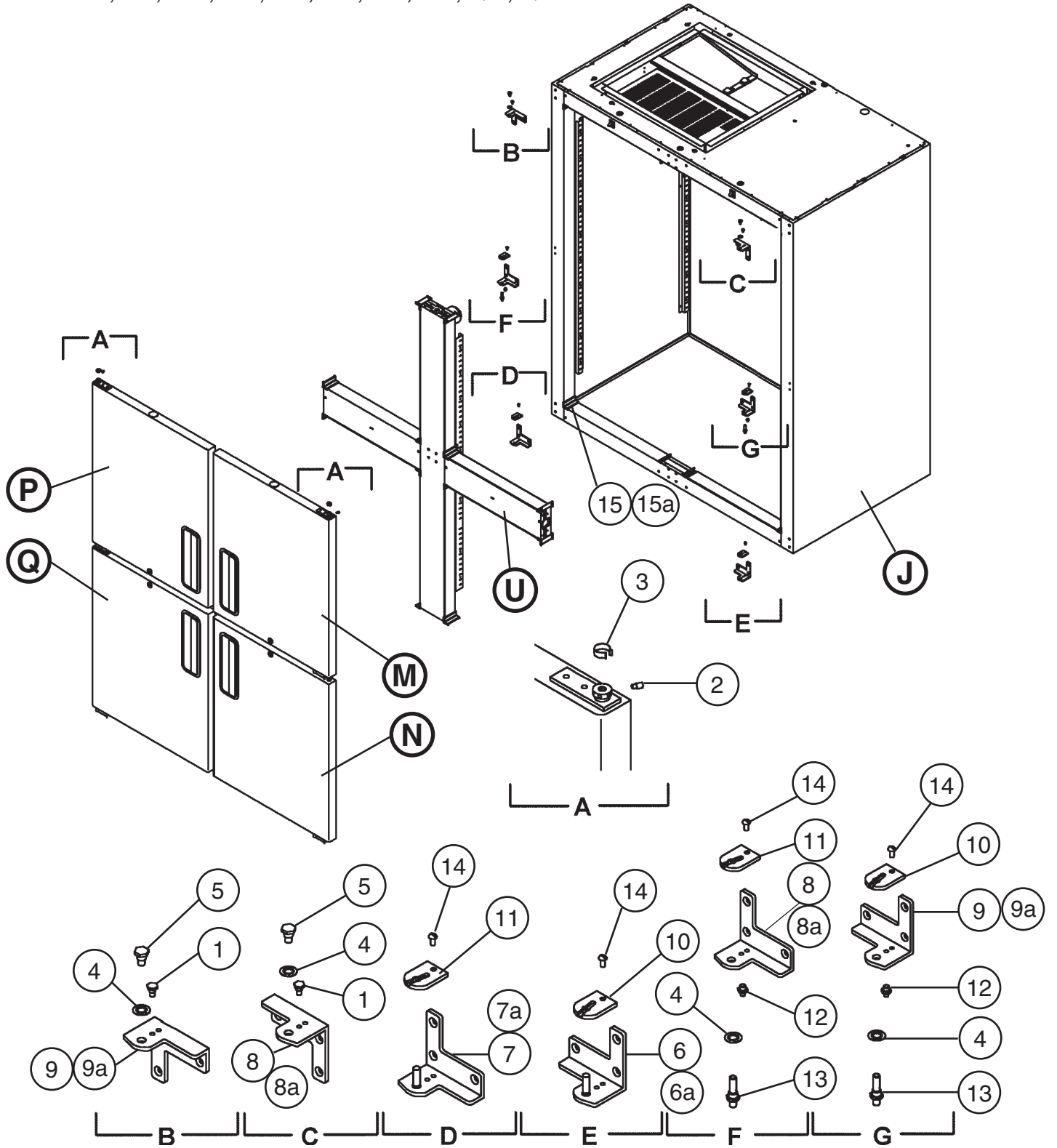

Title: **D. Body Final** Model: **FH2-AAC-HD**

| Index No. | Description               | Material or Model Number | Part Number | Required Number |  |  |  |  |  |  |  |  |  |  |  |  |  |  |  |  |
|-----------|---------------------------|--------------------------|-------------|-----------------|--|--|--|--|--|--|--|--|--|--|--|--|--|--|--|--|
|           |                           |                          |             | K-0 to Q-6      |  |  |  |  |  |  |  |  |  |  |  |  |  |  |  |  |
| J         | Body – Prefinal           | -                        | 2A1347A03   | 1               |  |  |  |  |  |  |  |  |  |  |  |  |  |  |  |  |
| M         | Door – Half (UR)          | -                        | 1A0326A03   | 1               |  |  |  |  |  |  |  |  |  |  |  |  |  |  |  |  |
| N         | Door – Half (LR)          | -                        | 1A0324A03   | 1               |  |  |  |  |  |  |  |  |  |  |  |  |  |  |  |  |
| P         | Door – Half (UL)          | -                        | 1A0324A04   | 1               |  |  |  |  |  |  |  |  |  |  |  |  |  |  |  |  |
| Q         | Door – Half (LL)          | -                        | 1A0326A04   | 1               |  |  |  |  |  |  |  |  |  |  |  |  |  |  |  |  |
| U         | Mullion – Cross           | -                        | 2A1350A03   | 1               |  |  |  |  |  |  |  |  |  |  |  |  |  |  |  |  |
| 1         | Hinge – Stop Pin          | PS                       | 4A2180-01   | 2               |  |  |  |  |  |  |  |  |  |  |  |  |  |  |  |  |
| 2         | Hinge – Tension Screw     | PS                       | 4A0446-01   | 4               |  |  |  |  |  |  |  |  |  |  |  |  |  |  |  |  |
| 3         | Hinge – Bushing Cover     | SS                       | 4A0445-01   | 4               |  |  |  |  |  |  |  |  |  |  |  |  |  |  |  |  |
| 4         | Hinge – Lock Washer       | PS                       | 4A0553-01   | 4               |  |  |  |  |  |  |  |  |  |  |  |  |  |  |  |  |
| 5         | Hinge – Pivot Pin (Top)   | PS                       | 4A2179-01   | 2               |  |  |  |  |  |  |  |  |  |  |  |  |  |  |  |  |
| 6         | Bracket – Door Hinge (LR) | PS                       | 3A1626-01   | 1               |  |  |  |  |  |  |  |  |  |  |  |  |  |  |  |  |
| 6a        | Countersunk Screw         | 5x10, SS                 | 7C42-0510   | 3               |  |  |  |  |  |  |  |  |  |  |  |  |  |  |  |  |
| 7         | Bracket – Door Hinge (LL) | PS                       | 3A1627-01   | 1               |  |  |  |  |  |  |  |  |  |  |  |  |  |  |  |  |
| 7a        | Countersunk Screw         | 5x10, SS                 | 7C42-0510   | 3               |  |  |  |  |  |  |  |  |  |  |  |  |  |  |  |  |
| 8         | Bracket – Door Hinge (UR) | PS                       | 3A1580-01   | 2               |  |  |  |  |  |  |  |  |  |  |  |  |  |  |  |  |
| 8a        | Countersunk Screw         | 5x10, SS                 | 7C42-0510   | 6               |  |  |  |  |  |  |  |  |  |  |  |  |  |  |  |  |
| 9         | Bracket – Door Hinge (UL) | PS                       | 3A1581-01   | 2               |  |  |  |  |  |  |  |  |  |  |  |  |  |  |  |  |
| 9a        | Countersunk Screw         | 5x10, SS                 | 7C42-0510   | 6               |  |  |  |  |  |  |  |  |  |  |  |  |  |  |  |  |
| 10        | Hinge – Stop Plate (R)    | PS                       | 4A0441-01   | 2               |  |  |  |  |  |  |  |  |  |  |  |  |  |  |  |  |
| 11        | Hinge – Stop Plate (L)    | PS                       | 4A0441-02   | 2               |  |  |  |  |  |  |  |  |  |  |  |  |  |  |  |  |
| 12        | Stop Pin                  | PS                       | 4A1734-01   | 2               |  |  |  |  |  |  |  |  |  |  |  |  |  |  |  |  |
| 13        | Pivot Pin                 | PS                       | 4A1735-01   | 2               |  |  |  |  |  |  |  |  |  |  |  |  |  |  |  |  |
| 14        | Screw – Stop Plate        | PS                       | 4A0483-01   | 4               |  |  |  |  |  |  |  |  |  |  |  |  |  |  |  |  |
| 15        | Cover – Corner            | ABS                      | 3A1751-01   | 16              |  |  |  |  |  |  |  |  |  |  |  |  |  |  |  |  |
| 15a       | Truss Head Screw          | 5x10, SS                 | 7C32-0510   | 26              |  |  |  |  |  |  |  |  |  |  |  |  |  |  |  |  |

**E. Control Box Assembly**  
**FH1-AAC(-HD), FH2-AAC(-HD)**

K-0, L-0, L-5, M-5, M-6, M-7, M-8, N-5, N-6, P-5, P-6, P-7, P-8, Q-5, Q-6

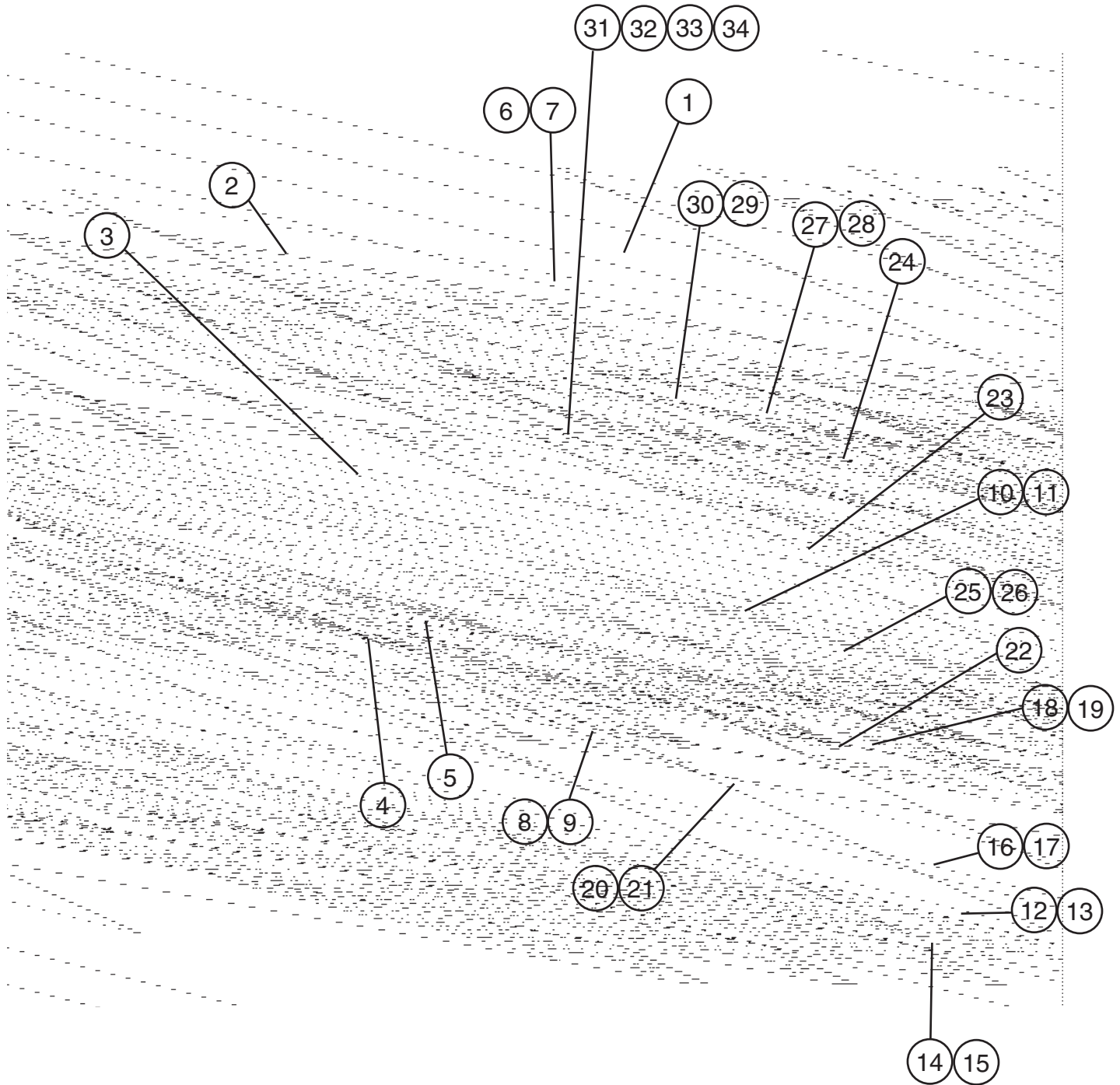



Title: **E. Control Box Assembly** Model: **FH1-AAC(-HD), FH2-AAC(-HD)**

| Index No. | Description                | Material or Model Number                   | Part Number | Required Number |            |     |     |         |     |     |   |  |  |
|-----------|----------------------------|--|-------------|-----------------|------------|-----|-----|---------|-----|-----|---|--|--|
|           |                            |  |             | K-0 to M-5      | M-6 to M-8 | N-5 | P-5 | P-6 P-7 | Q-5 | Q-6 |   |  |  |
| 1         | Base – Control Box         | GS   | 2A1887-01   | 1               | 1          | 1   | 1   | 1       | 1   | 1   |   |  |  |
| 2         | Cover – Control Box        | GS   | 2A1833-01   | 1               | 1          | 1   | 1   | 1       | 1   | 1   |   |  |  |
| 3         | Board – Control Display    | Use latest for all aux. codes              | 4A2203-02   | 1               | 1          | 1   | 1   | -       |     |     |   |  |  |
|           |                            |  | 4A2203-05   |                 |            |     |     | 1       | -   |     |   |  |  |
|           | Controller                 |  | 3A3372-05   |                 |            |     |     |         | 1   | -   |   |  |  |
|           | 3A3656-06                  |  |             |                 |            |     |     |         |     | 1   |   |  |  |
| 4         | Switch – Rocker            | 1801.110                                   | 4A0418-01   | 1               | 1          | 1   | 1   | 1       | 1   | 1   |   |  |  |
| 5         | Switch – Toggle            | 780K21                                     | 4A0424-01   | 1               | 1          | 1   | 1   | 1       | 1   | 1   |   |  |  |
| 6         | Relay – Compressor         | HE1aN-AC120V                               | 4A1307-01   | 1               | 1          | 1   | 1   | 1       | 1   | 1   |   |  |  |
| 7         | Tapping Screw              | 3x8  | 431415-01   | 1               | 1          | 1   | 1   | 1       | 1   | 1   |   |  |  |
| 8         | Transformer                | BE110805GAA                                | 4A2202-01   | 1               | 1          | 1   | 1   | 1       | 1   | 1   |   |  |  |
| 9         | Tapping Screw              | 3x8  | 431415-01   | 2               | 2          | 2   | 2   | 2       | 2   | 2   |   |  |  |
| 10        | Terminal Block             | <b>FH1-AAC(-HD)</b><br><b>FH2-AAC(-HD)</b> | 4A1540-01   | 1               | -          |     |     |         |     |     |   |  |  |
|           |                            |  | 4A2619-01   |                 | 1          | 1   | 1   | 1       | 1   | 1   | 1 |  |  |
| 11        | Tapping Screw              | 3x8  | 431415-01   | 1               | 2          | 2   | 2   | 2       | 2   | 2   |   |  |  |
| 12        | Plug Housing               | 3/12/35                                    | 4A0425-01   | 1               | 1          | 1   | 1   | 1       | 1   | 1   |   |  |  |
| 13        | Receptacle Housing         | 03-12-1036                                 | 4A0426-01   | 1               | 1          | 1   | 1   | 1       | 1   | 1   |   |  |  |
| 14        | Plug Housing (6 Pin)       | 3191-06P                                   | 412832-03   | 1               | 1          | 1   | 1   | 1       | 1   | 1   |   |  |  |
| 15        | Receptacle Housing (6 Pin) | 3191-06R1                                  | 412831-03   | 1               | 1          | 1   | 1   | 1       | 1   | 1   |   |  |  |
| 16        | Plug Housing (6 Pin)       | 3191-06P                                   | 412832-12   | 1               | 1          | 1   | 1   | 1       | 1   | 1   |   |  |  |
| 17        | Receptacle Housing (6 Pin) | 3191-06R1                                  | 412831-12   | 1               | 1          | 1   | 1   | 1       | 1   | 1   |   |  |  |
| 18        | Threaded Insert            | M5   | 4A0407-01   | 1               | 1          | 1   | 1   | 1       | 1   | 1   |   |  |  |
| 19        | Truss Head Screw           | 5x10, SS                                   | 7C32-0510   | 1               | 1          | 1   | 1   | 1       | 1   | 1   |   |  |  |
| 20        | Relay – Door Switch        | <b>FH1-AAC(-HD)</b><br><b>FH2-AAC(-HD)</b> | 4A2268-01   | 1               | -          |     |     |         |     |     |   |  |  |
|           |                            |  | 4A2607-01   |                 | 1          | 1   | 1   | 1       | 1   | 1   | 1 |  |  |
| 21        | Tapping Screw              | 3x8  | 431415-01   | 2               | 2          | 2   | 2   | 2       | 2   | 2   |   |  |  |
| 22        | Bushing                    | SB-625-8                                   | 420470-01   | 2               | 2          | 2   | 2   | 2       | 2   | 2   |   |  |  |
| 23        | Capacitor – Run            | <b>FH1-AAC(-HD)</b>                        | 439943-04   | 1               | -          |     |     |         |     |     |   |  |  |
|           |                            |  | 3A2005-08   |                 | 1          | 1   | 1   | 1       | 1   | 1   | 1 |  |  |
|           |                            | <b>FH2-AAC(-HD)</b>                        | 439943-02   | 1               | -          |     |     |         |     |     |   |  |  |
|           |                            |  | 3A2005-06   |                 | 1          | 1   | 1   | 1       | 1   | 1   | 1 |  |  |
| 24        | Capacitor – Start          | <b>FH1-AAC(-HD)</b><br><b>FH2-AAC(-HD)</b> | 3A0076-06   | 1               | 1          | 1   | 1   | 1       | 1   | 1   |   |  |  |
|           |                            |  | 3A0076-07   | 1               | 1          | 1   | 1   | 1       | 1   | 1   | 1 |  |  |
| 25        | Starter                    | <b>FH1-AAC(-HD)</b><br><b>FH2-AAC(-HD)</b> | 4A1107-03   | 1               | 1          | 1   | 1   | 1       | 1   | 1   | 1 |  |  |
|           |                            |  | 434172-01   | 1               | 1          | 1   | -   |         |     |     |   |  |  |
|           |                            |  | 4A1107-13   |                 |            |     |     | 1       | 1   | 1   | 1 |  |  |
| 26        | Tapping Screw              | 3x8  | 431415-01   | 1               | 1          | 1   | 1   | 1       | 1   | 1   |   |  |  |
| 27        | Strap                      | <b>FH1-AAC(-HD)</b>                        | 434580-08   | 1               | 1          | 1   | 1   | 1       |     |     |   |  |  |
|           |                            |  | 434580-14   |                 |            |     |     |         |     | 1   | 1 |  |  |
|           |                            | <b>FH2-AAC(-HD)</b>                        | 434580-20   | 1               | 1          | 1   | 1   | 1       | 1   | 1   | 1 |  |  |
| 28        | Tapping Screw              | 3x8  | 431415-01   | 1               | 1          | 1   | 1   | 1       | 1   | 1   |   |  |  |
| 29        | Relay – Defrost            | -  | 4A2266-01   | 1               | 1          | 1   | 1   | 1       | 1   | 1   |   |  |  |
| 30        | Tapping Screw              | 3x8  | 431415-01   | 2               | 2          | 2   | 2   | 2       | 2   | 2   |   |  |  |
| 31        | Bracket – Fuse             | GS   | 4A3359-01   |                 |            |     |     | 1       | 1   | 1   |   |  |  |

| Title: <b>E. Control Box Assembly</b> Model: <b>FH1-AAC(-HD), FH2-AAC(-HD)</b> |             |                          |             |                 |            |     |     |         |     |     |  |  |
|--|-------------|--------------------------|-------------|-----------------|------------|-----|-----|---------|-----|-----|--|--|
| Index No.  | Description | Material or Model Number | Part Number | Required Number |            |     |     |         |     |     |  |  |
|  |             |                          |             | K-0 to M-5      | M-6 to M-8 | N-5 | P-5 | P-6 P-7 | Q-5 | Q-6 |  |  |
| 32   | T2 Screw    | 4x8, SS                  | 7P32-0408   |                 |            |     |     | 2       | 2   | 2   |  |  |
| 33   | Fuse Holder | HTB92I                   | 4A0892-01   |                 |            |     |     | 1       | 1   | 1   |  |  |
| 34   | Fuse        | AGC-55A250V              | 4A0893-09   |                 |            |     |     | 1       | 1   | 1   |  |  |

## F. Fan-Evaporator Assembly

### FH1-AAC(-HD)

K-0, L-0, L-5, M-5

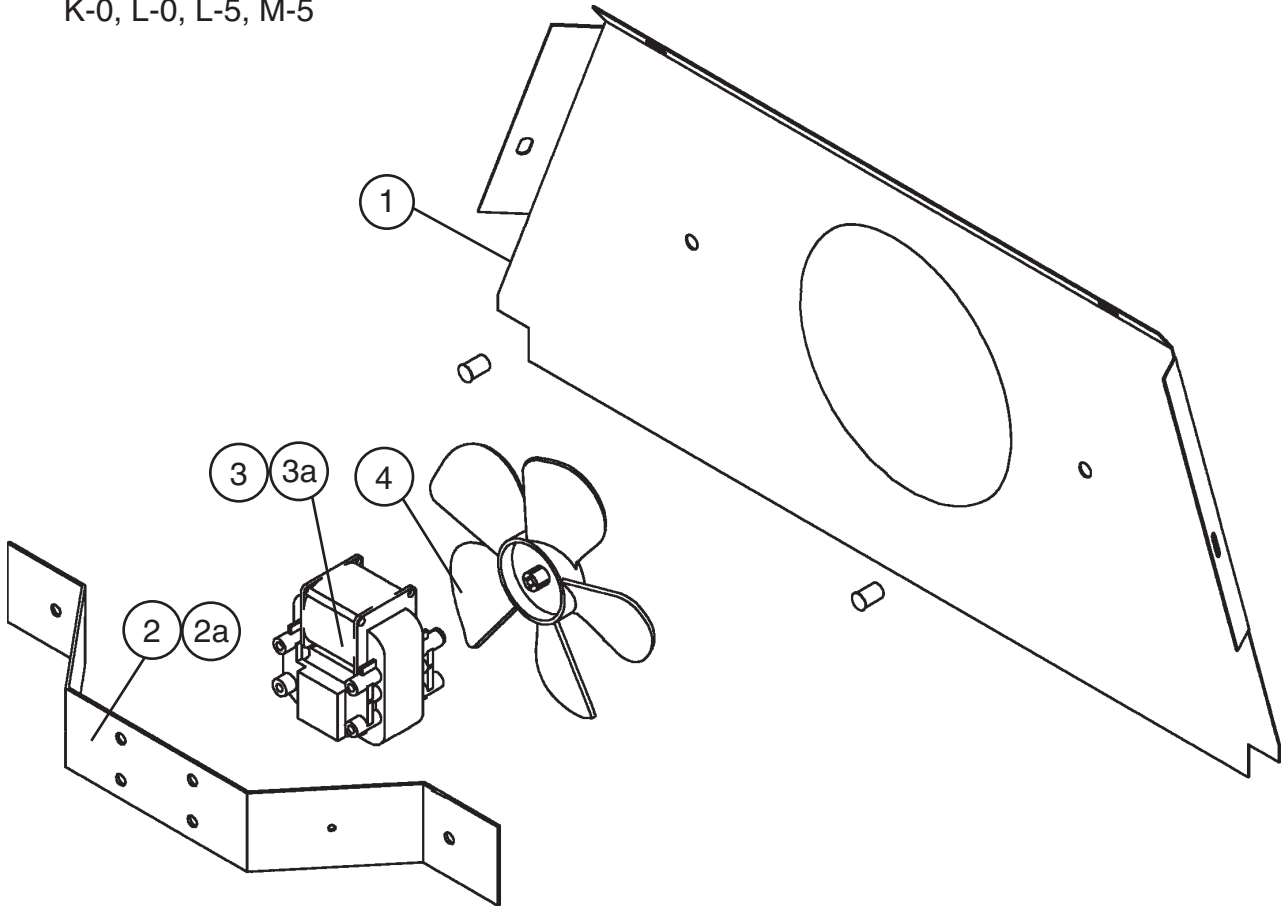

## F. Fan-Evaporator Assembly

### FH1-AAC(-HD)

M-6, M-7, N-5, N-6, P-5, P-6, P-7, P-8, Q-5, Q-6

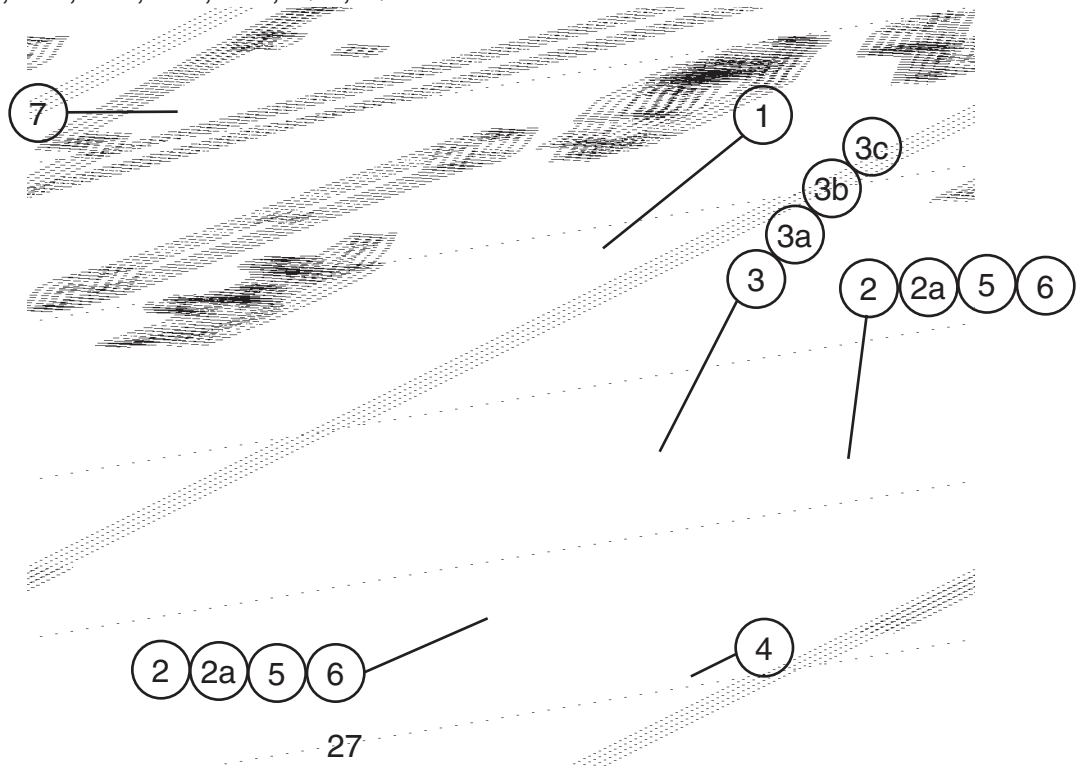

| Title: <b>F. Fan-Evaporator Assembly</b> Model: <b>FH1-AAC(-HD)</b> |                         |                          |             |                 |            |            |  |  |  |  |  |  |  |  |
|---|-------------------------|--------------------------|-------------|-----------------|------------|------------|--|--|--|--|--|--|--|--|
| Index No.   | Description             | Material or Model Number | Part Number | Required Number |            |            |  |  |  |  |  |  |  |  |
|   |                         |                          |             | K-0 to M-5      | M-6 to P-5 | P-6 to Q-6 |  |  |  |  |  |  |  |  |
| 1   | Shroud – Evaporator Fan | SS                       | 2A0846-01   | -               |            |            |  |  |  |  |  |  |  |  |
|   |                         |                          | 2A2565G01   | 1               | -          |            |  |  |  |  |  |  |  |  |
|   |                         |                          | 2A2565G02   |                 | 1          |            |  |  |  |  |  |  |  |  |
| 2   | Bracket – Fan Motor     | -                        | 3A2480-01   | 2               | 2          |            |  |  |  |  |  |  |  |  |
| 2a  | Truss Head Screw        | 5x12, SS                 | 7C32-0512   | 2               | 2          |            |  |  |  |  |  |  |  |  |
| 3   | Motor – Fan Evap        | JAKEL J238-100-10070     | 4A1132-01   | -               |            |            |  |  |  |  |  |  |  |  |
|   |                         | -                        | 4A2563-01   | 1               | 1          |            |  |  |  |  |  |  |  |  |
| 3a  | Truss Head Screw        | 4x40, SS                 | 7C32-0440   | 4               | 4          |            |  |  |  |  |  |  |  |  |
| 3b  | Split Lock Washer       | M4, SS                   | 7L22-0400   | 4               | 4          |            |  |  |  |  |  |  |  |  |
| 3c  | Hex Nut                 | M4, SS                   | 7N12-0400   | 4               | 4          |            |  |  |  |  |  |  |  |  |
| 4   | Blade – Fan             | THORGREN 5562C3125L1     | 4A1131-01   | -               |            |            |  |  |  |  |  |  |  |  |
|   |                         | -                        | 4A2802-01   | 1               | 1          |            |  |  |  |  |  |  |  |  |
| 5   | Lock – Washer           | -                        | 4A0459-01   | 2               | 2          |            |  |  |  |  |  |  |  |  |
| 6   | Wire Tie (Twist)        | -                        | 4A1223-01   | 2               | 2          |            |  |  |  |  |  |  |  |  |
| 7   | Bushing                 | SB-625-8                 | 420470-01   | 1               | 1          |            |  |  |  |  |  |  |  |  |

Note: Parts are not interchangeable. For auxiliary codes prior to M-6, order HS-3545 and replace the entire assembly. For auxiliary codes M-6 and later, order appropriate part from this chart.

# F. Evap-Shroud Assembly FH2-AAC(-HD)

K-0, L-5, M-5, M-6, M-7, M-8, N-5, N-6, P-5, P-6, P-7, P-8, Q-5, Q-6

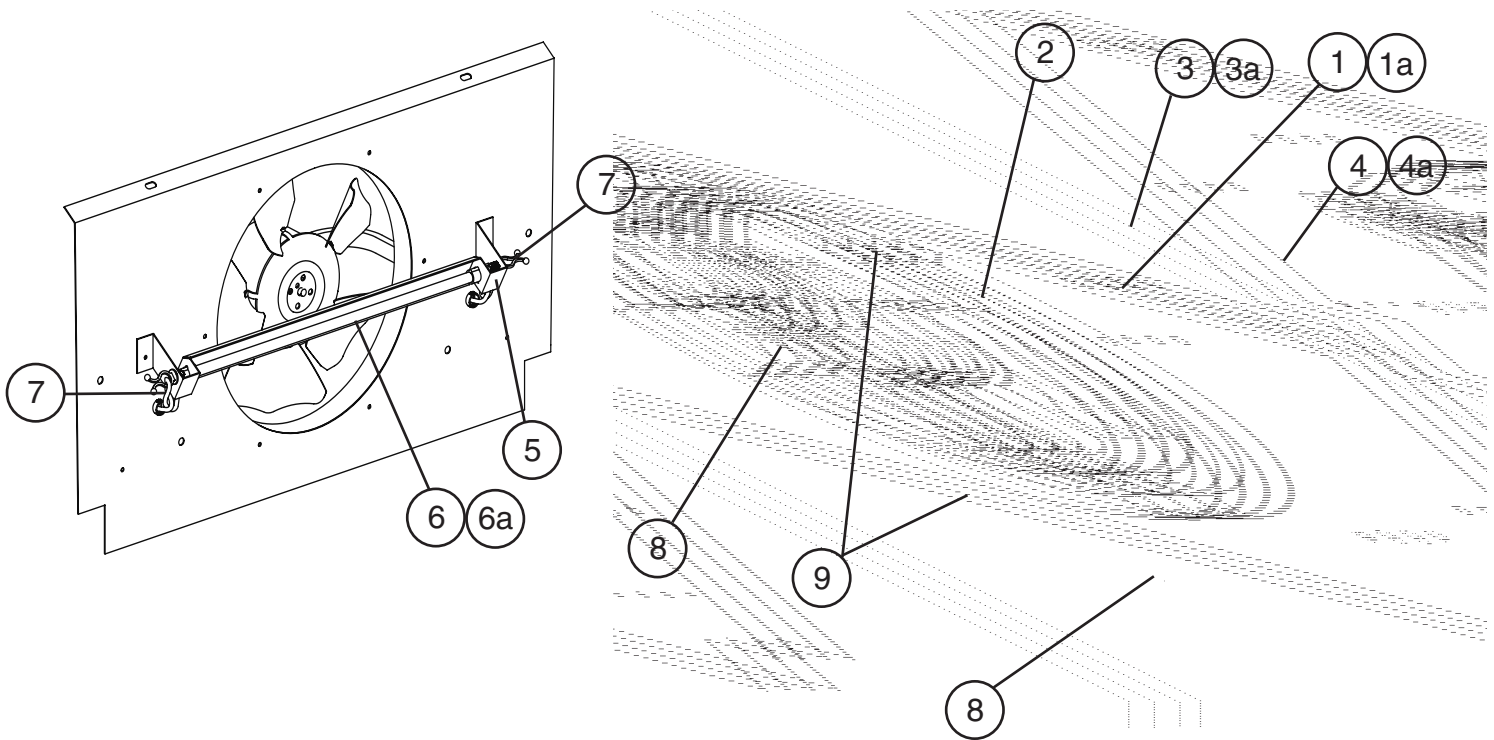

| Title: F. Evap-Shroud Assembly Model: FH2-AAC(-HD) |                         |                            |             |                 |            |  |  |  |  |  |  |
|--|-------------------------|----------------------------|-------------|-----------------|------------|--|--|--|--|--|--|
| Index No.  | Description             | Material or Model Number   | Part Number | Required Number |            |  |  |  |  |  |  |
|  |                         |                            |             | K-0 to P-5      | P-6 to Q-6 |  |  |  |  |  |  |
| 1  | Blade – Fan (Pusher)    | AIR DRIVE INC. AD9CCW30UBA | 3A0438-01   | 1               | 1          |  |  |  |  |  |  |
| 1a   | Lock Washer             |                            | 4A0459-01   | 1               | 1          |  |  |  |  |  |  |
| 2  | Motor – Evap Fan        | MORRILL PSC4BE9BEA1        | 4A0413-01   | 1               | 1          |  |  |  |  |  |  |
| 3  | Orifice – Evap Fan      | SS                         | 4A0412-01   | 1               | 1          |  |  |  |  |  |  |
| 3a   | T2 Screw                | 4x8, SS                    | 7P32-0408   | 3               | 3          |  |  |  |  |  |  |
| 4  | Shroud – Evap Fan       | SS                         | 1A0100-01   | 1               | -          |  |  |  |  |  |  |
| 4a   | Hex Nut                 |                            | 4A1345-01   | 1               | 1          |  |  |  |  |  |  |
| 5  | Bracket – Heater Supply | -                          | 3A3243-01   |                 | 1          |  |  |  |  |  |  |
| 6  | Heater – Glass Tube     | -                          | 3A2335-02   |                 | 1          |  |  |  |  |  |  |
| 6a   | T2 Screw                | 4x8                        | 7P32-0408   |                 | 2          |  |  |  |  |  |  |
| 7  | Wire Tie (Twist)        | -                          | 4A1223-01   |                 | 4          |  |  |  |  |  |  |
| 8  | Bushing                 | -                          | 428394-02   |                 | 2          |  |  |  |  |  |  |
| 9  | Nylon Tie               | CV-100                     | 8911-0100   |                 | 4          |  |  |  |  |  |  |

# G. Evaporator Assembly FH1-AAC(-HD)

K-0, L-0, L-5, M-5, M-6, M-7, N-5, N-6, P-5, P-6, P-7, P-8, Q-5, Q-6

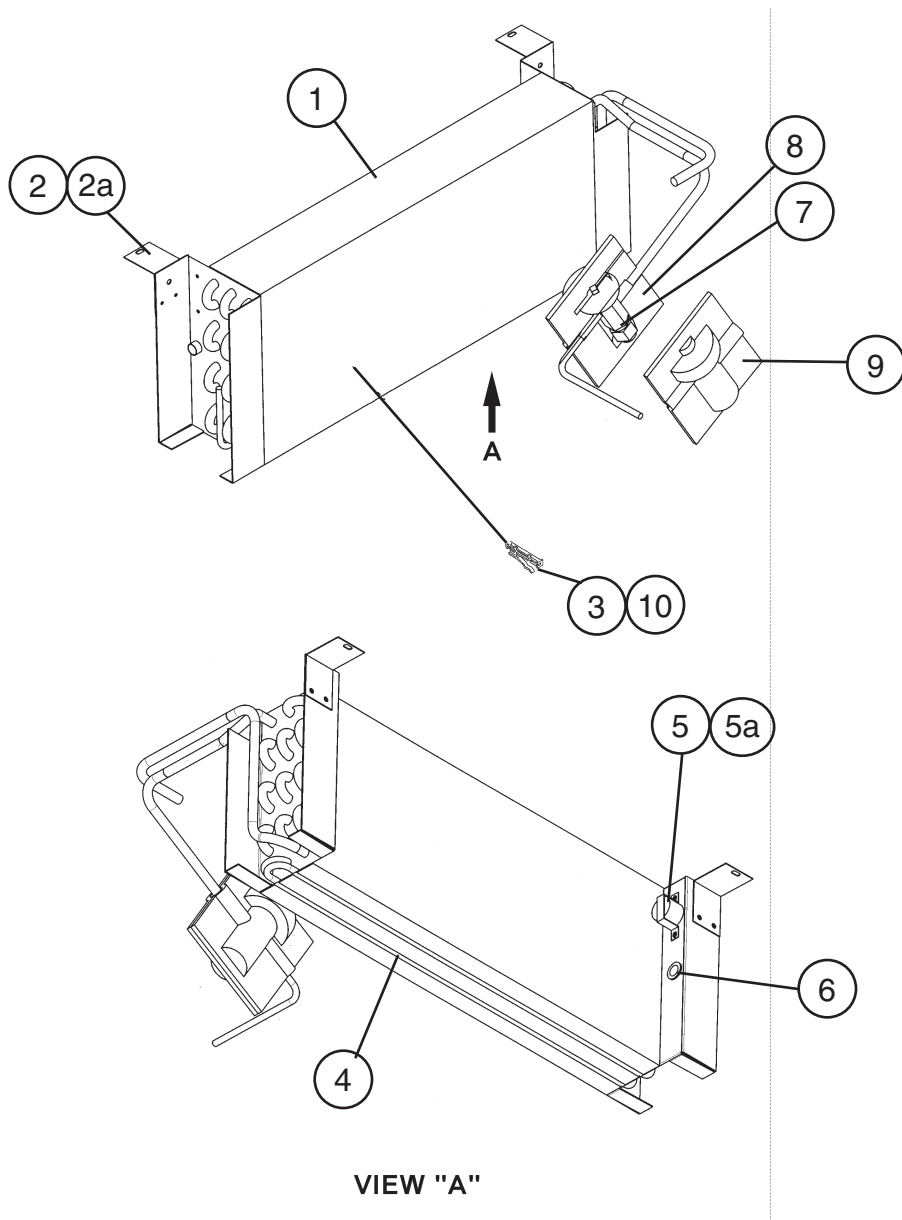

| Title: <b>G. Evaporator Assembly</b> Model: <b>FH1-AAC(-HD)</b> |                           |  |             |                 |            |            |  |  |  |  |  |  |
|---|---------------------------|--|-------------|-----------------|------------|------------|--|--|--|--|--|--|
| Index No.   | Description               | Material or Model Number   | Part Number | Required Number |            |            |  |  |  |  |  |  |
|   |                           |  |             | K-0             | L-0 to P-5 | P-6 to Q-6 |  |  |  |  |  |  |
| 1   | Evaporator                | -  | 2A0781-01   | 1               | 1          | 1          |  |  |  |  |  |  |
| 2   | Bracket – Evaporator      | SS   | 4A2542-01   | 2               | 2          | 2          |  |  |  |  |  |  |
| 2a  | T2 Screw                  | 4x8, SS  | 7P32-0408   | 4               | 4          | 4          |  |  |  |  |  |  |
| 3   | Thermistor – Defrost      | Thermistor is to be replaced using kit HS-3540. Apply to all aux. codes. |             | -               | -          | -          |  |  |  |  |  |  |
|   | Clip – Thermistor         |  | 4A3248G01   | 1               | 1          | 1          |  |  |  |  |  |  |
| 4   | Heater – Defrost          | -  | 3A0846-01   | 1               | 1          | 1          |  |  |  |  |  |  |
| 5   | Thermistat – Defrost      | -  | 4A0954-02   | 1               | 1          | 1          |  |  |  |  |  |  |
| 5a  | T2 Screw                  | 4x8, SS  | 7P32-0408   | 2               | 2          | 2          |  |  |  |  |  |  |
| 6   | Bushing                   | 0CB-500  | 428394-02   | 1               | 1          | 1          |  |  |  |  |  |  |
| 7   | Expansion Valve           | -  | 4A1135-01   | 1               | 1          | 1          |  |  |  |  |  |  |
| 8   | Expansion Valve Cover (A) | -  | 3A0372-01   | 1               | 1          | 1          |  |  |  |  |  |  |
| 9   | Expansion Valve Cover (B) | -  | 3A0372-02   | 1               | 1          | 1          |  |  |  |  |  |  |
| 10  | Nylon Tie                 |  | 8911-0150   |                 |            | 1          |  |  |  |  |  |  |

**G. Evaporator Assembly  
FH2-AAC(-HD)**

K-0, L-5, M-5, M-6, M-7, M-8, N-5, N-6, P-5, P-6, P-7, P-8, Q-5, Q-6

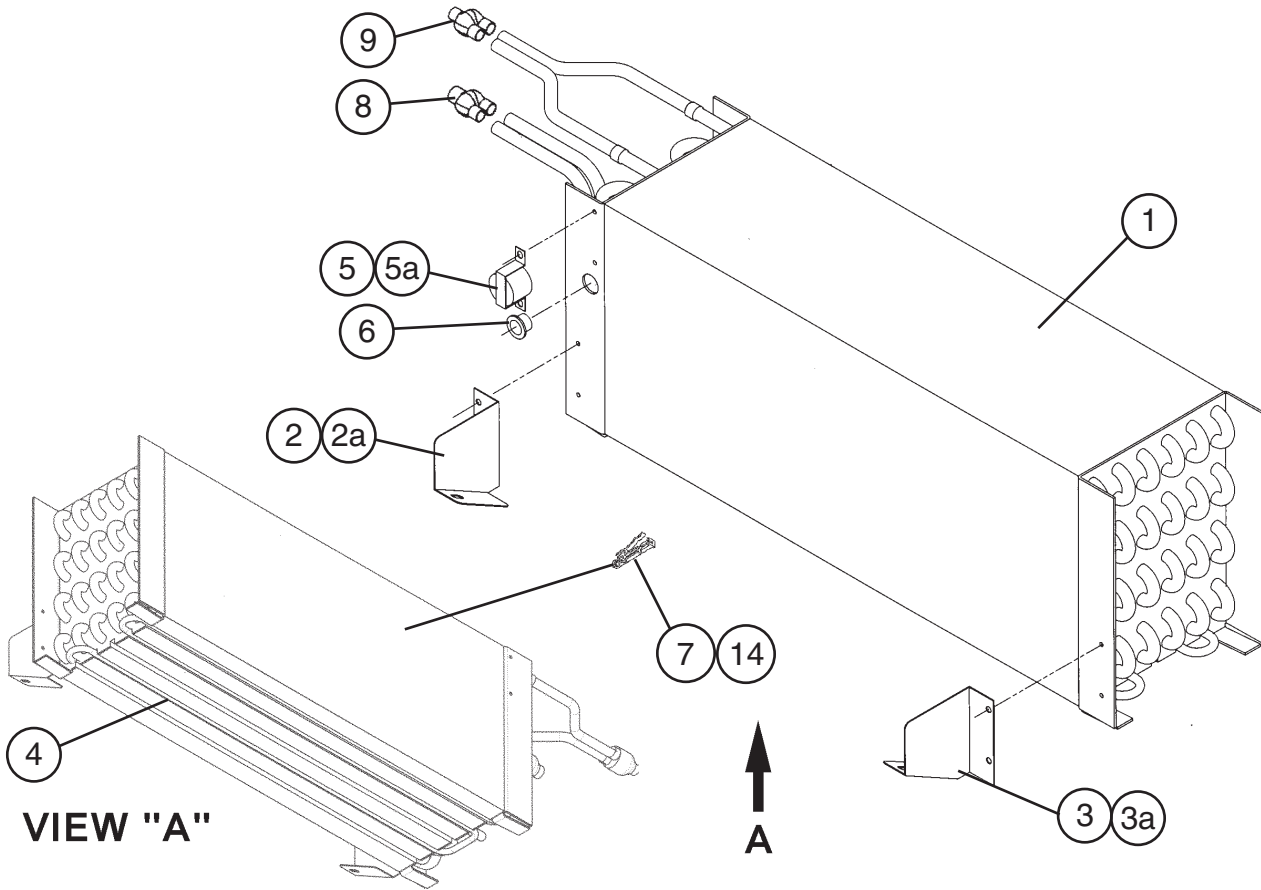

These additional parts added to FH2-AAC(-HD) Evaporator Assembly at aux. code M-6

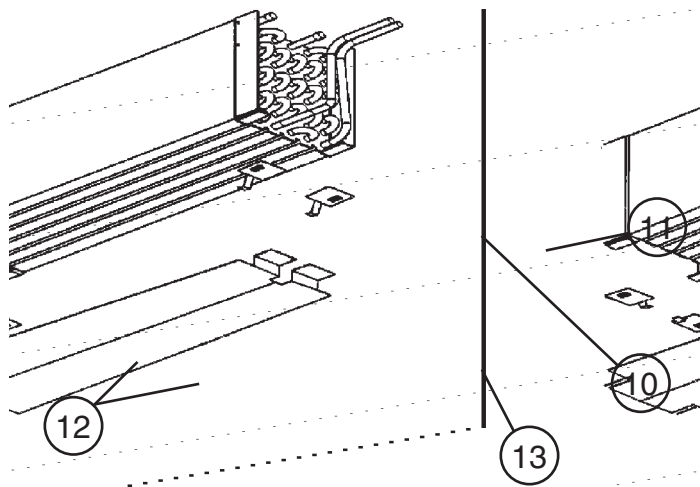



| Title: <b>G. Evaporator Assembly</b> Model: <b>FH2-AAC(-HD)</b> |                         |  |             |                 |            |     |            |  |  |  |  |
|---|-------------------------|--|-------------|-----------------|------------|-----|------------|--|--|--|--|
| Index No.   | Description             | Material or Model Number   | Part Number | Required Number |            |     |            |  |  |  |  |
|   |                         |  |             | K-0 to M-5      | M-6 to P-5 | P-6 | P-7 to Q-6 |  |  |  |  |
| 1   | Evaporator              | -  | 2A0636-01   | 1               | 1          | 1   | 1          |  |  |  |  |
| 2   | Bracket-Evap Shroud (R) | SS   | 4A0545-01   | 1               | 1          | -   |            |  |  |  |  |
| 2a  | T2 Screw                | 4x8, SS  | 7P32-0408   | 2               | 2          | -   |            |  |  |  |  |
| 3   | Bracket-Evap Shroud (L) | SS   | 4A0548-01   | 1               | 1          | -   |            |  |  |  |  |
| 3a  | T2 Screw                | 4x8, SS  | 7P32-0408   | 2               | 2          | -   |            |  |  |  |  |
| 4   | Heater – Defrost        | -  | 3A0591-01   | 1               | 1          | 1   | 1          |  |  |  |  |
| 5   | Thermostat – Defrost    | -  | 4A0954-02   | 1               | 1          | 1   | 1          |  |  |  |  |
| 5a  | T2 Screw                | 4x8, SS  | 7P32-0408   | 2               | 2          | 2   | 2          |  |  |  |  |
| 6   | Bushing                 | -  | 420470-01   | 1               | 1          | 1   | 1          |  |  |  |  |
| 7   | Thermistor – Defrost    | Thermistor is to be replaced using kit HS-3540. Apply to all aux. codes. |             | -               | -          | -   | -          |  |  |  |  |
|   | Thermistor – Clip       |  | 320418-01   | 1               | 1          | 1   | 1          |  |  |  |  |
| 8   | “Y” Joint               | -  | 4A1687-03   | 1               | 1          | 1   | 1          |  |  |  |  |
| 9   | “Y” Joint               | -  | 4A1687-02   | 1               | 1          | 1   | 1          |  |  |  |  |
| 10  | Clip – Support Evap (A) | -  | 4A2826-01   |                 | 1          | 1   | 1          |  |  |  |  |
| 11  | Clip – Support Evap (B) | -  | 4A2827-01   |                 | 1          | 1   | 1          |  |  |  |  |
| 12  | Clip – Support Evap (C) | -  | 4A2828-01   |                 | 2          | 2   | 2          |  |  |  |  |
| 13  | Shield – Heat           | -  | 3A1853G01   |                 | 1          | 1   | 1          |  |  |  |  |
| 14  | Nylon Tie               | -  | 8911-0150   |                 |            |     | 1          |  |  |  |  |

### Installation Instructions for Parts 10, 11, 12, & 13

1. The original heat shield must be removed. This can be done by lifting the evaporator up and sliding the heat shield out.
2. The new heat shield (part #13) is then installed in the rotocast drain pan.
3. The clips are then slid onto the end plate on the evaporator. Support clips (part #12) are installed onto the hairpin end of the evaporator as shown in the illustration.
4. The other support clips (parts #10 and #11) are installed on the return bend end (same side as inlet and outlet tubes) as shown in the illustration.

NOTE: All clips are shown in the illustration in the correct orientation for installation. The parts are slid onto the evaporator bracket using the tab on the support clip.

## H. Condenser Assembly

### FH1-AAC(-HD)

K-0, L-0, L-5, M-5, M-6, M-7, N-5, N-6, P-5, P-6, P-7, P-8, Q-5, Q-6

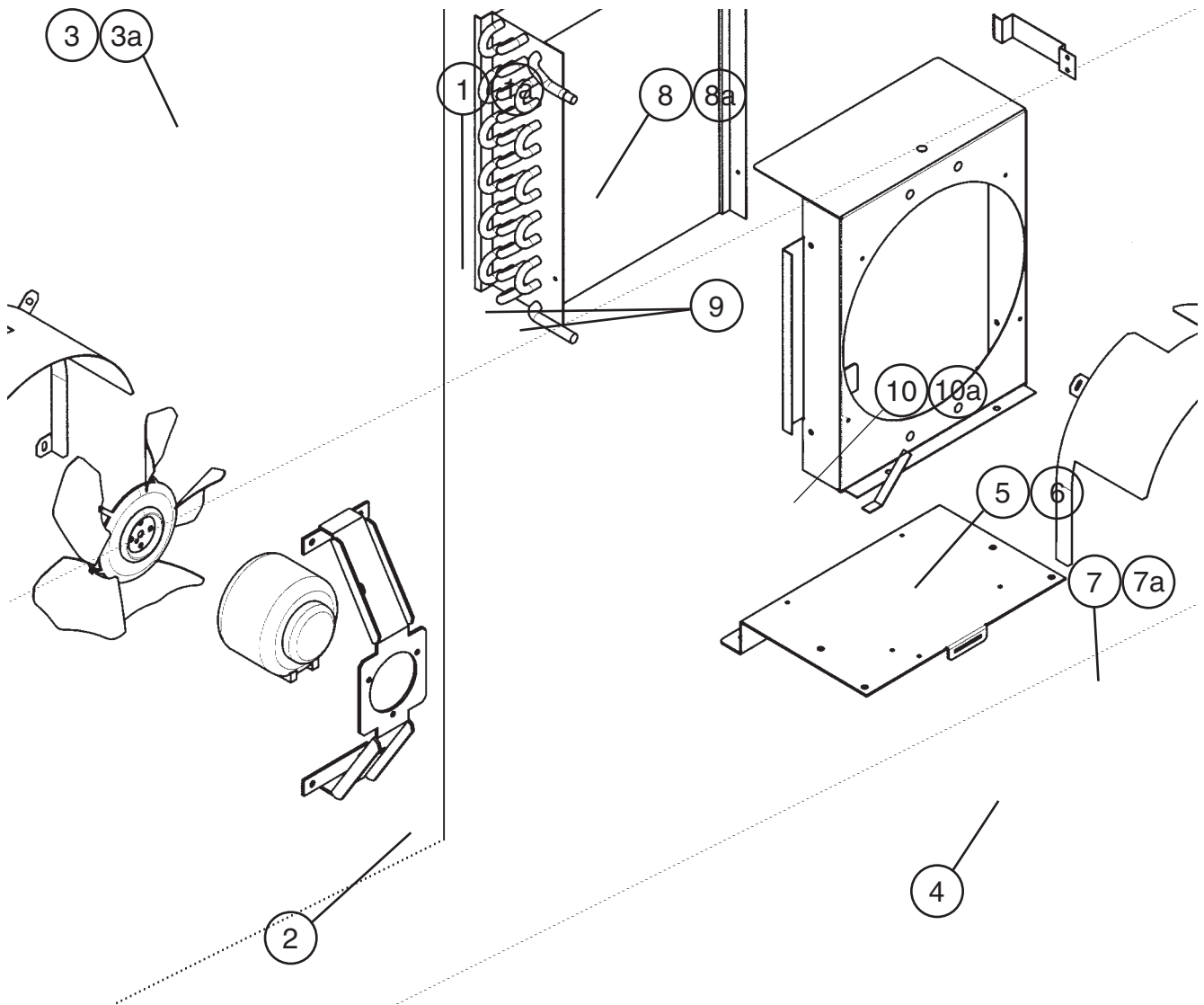

| Title: <b>H. Condenser Assembly</b> Model: <b>FH1-AAC(-HD)</b> |                              |                          |             |                 |            |  |  |  |  |  |  |
|--|------------------------------|--------------------------|-------------|-----------------|------------|--|--|--|--|--|--|
| Index No.  | Description                  | Material or Model Number | Part Number | Required Number |            |  |  |  |  |  |  |
|  |                              |                          |             | K-0 to N-5      | N-6 to Q-6 |  |  |  |  |  |  |
| 1  | Shroud – Condenser           | GS                       | 2A1685-02   | 1               | -          |  |  |  |  |  |  |
|  |                              |                          | 2A2722-02   |                 | 1          |  |  |  |  |  |  |
| 1a   | T2 Screw                     | 4x8, SS                  | 7P32-0408   | 4               | 4          |  |  |  |  |  |  |
| 2  | Base – Condenser             | GS                       | 2A1027G01   | 1               | -          |  |  |  |  |  |  |
|  |                              |                          | 2A2724G01   |                 | 1          |  |  |  |  |  |  |
| 3  | Condenser                    | -                        | 2A0782-01   | 1               | 1          |  |  |  |  |  |  |
| 3a   | T2 Screw                     | 4x8, SS                  | 7P32-0408   | 4               | 4          |  |  |  |  |  |  |
| 4  | Fan Motor                    | -                        | 4A1179-01   | 1               | 1          |  |  |  |  |  |  |
| 5  | Blade – Cond Fan             | -                        | 3A0608-01   | 1               | 1          |  |  |  |  |  |  |
| 6  | Hex Nut                      | PS                       | 4A1345-01   | 1               | 1          |  |  |  |  |  |  |
| 7  | Bracket – Condenser Fan      | GS                       | 3A1564-01   | 1               | 1          |  |  |  |  |  |  |
| 7a   | Truss Head Screw             | 5x12, SS                 | 7C32-0512   | 4               | 4          |  |  |  |  |  |  |
| 8  | Retainer – Filter            | GS                       | 4A0790-01   | 1               | 1          |  |  |  |  |  |  |
| 8a   | T2 Screw                     | 4x8, SS                  | 7P32-0408   | 2               | 2          |  |  |  |  |  |  |
| 9  | Threaded Insert              | -                        | 4A0407-01   | 5               | 5          |  |  |  |  |  |  |
| 10   | Extension – Condenser Shroud | -                        | 3A1747-01   | 1               | 1          |  |  |  |  |  |  |
| 10a  | T2 Screw                     | 4x8, SS                  | 7P32-0408   | 4               | 4          |  |  |  |  |  |  |

# H. Condenser Assembly FH2-AAC(-HD)

K-0, L-5, M-5, M-6, M-7, M-8, N-5, N-6, P-5, P-6, P-7, P-8, Q-5, Q-6

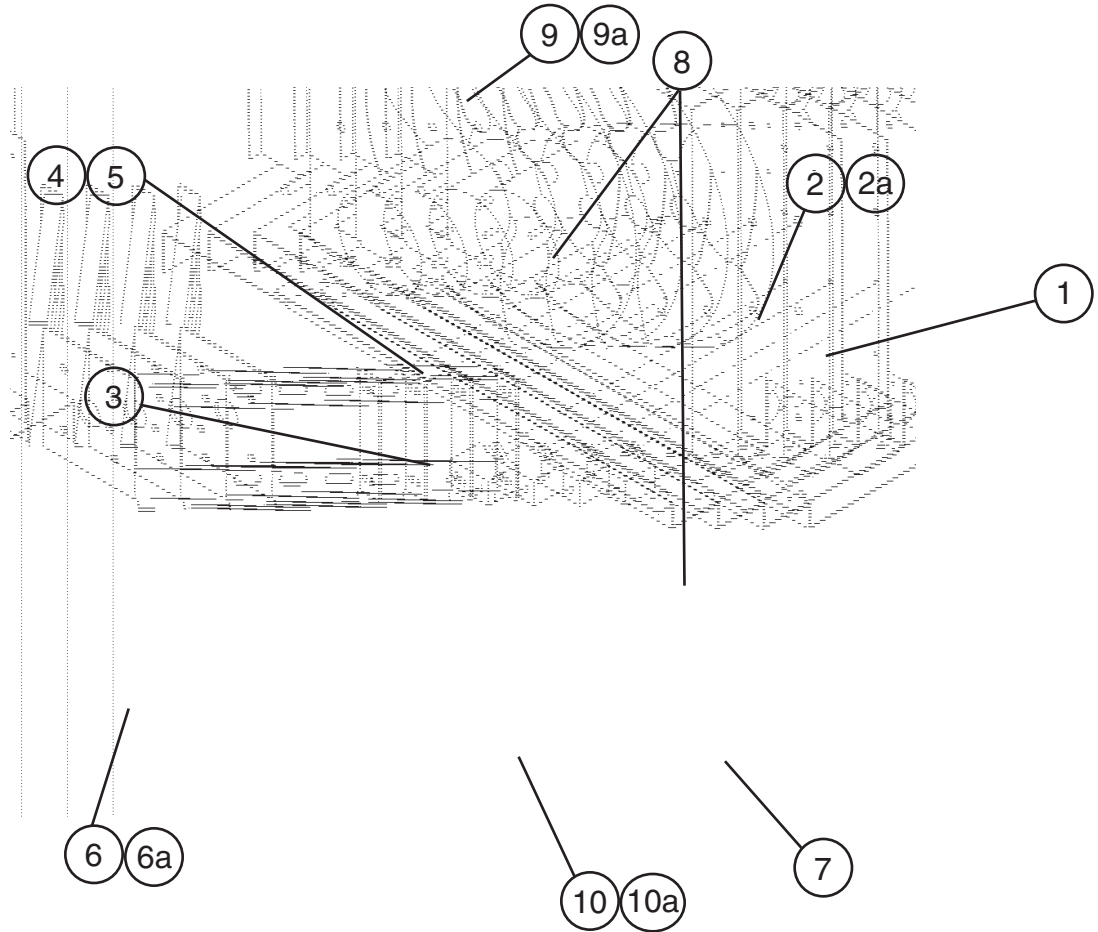

| Title: H. Condenser Assembly |                        | Model: FH2-AAC(-HD)      |             | Required Number |        |  |  |  |  |  |  |
|------------------------------|------------------------|--------------------------|-------------|-----------------|--------|--|--|--|--|--|--|
| Index No.                    | Description            | Material or Model Number | Part Number | K-0             | P-6    |  |  |  |  |  |  |
|                              |                        |                          |             | to P-5          | to Q-6 |  |  |  |  |  |  |
| 1                            | Condenser              | -                        | 2A0638-01   | 1               | 1      |  |  |  |  |  |  |
| 2                            | Shroud – Condenser     | GS                       | 2A1491-01   | 1               | 1      |  |  |  |  |  |  |
| 2a                           | T2 Screw               | 4x8, SS                  | 7P32-0408   | 8               | -      |  |  |  |  |  |  |
|                              |                        | 4x12, SS                 | 7P32-0412   |                 | 8      |  |  |  |  |  |  |
| 3                            | Fan Motor              | -                        | 440911-01   | 1               | -      |  |  |  |  |  |  |
|                              |                        |                          | 4A3158-01   |                 | 1      |  |  |  |  |  |  |
| 4                            | Fan Blade (Puller)     | -                        | 4a1865-01   | 1               | 1      |  |  |  |  |  |  |
| 5                            | Self – Locking Nut     | 8 x 32                   | 7N21I0832   | 4               | 4      |  |  |  |  |  |  |
| 6                            | Bracket – Cond Fan Mtr | GS                       | 2A1668-01   | 1               | 1      |  |  |  |  |  |  |
| 6a                           | Truss Head Screw       | 5x12                     | 7C32-0512   | 4               | 4      |  |  |  |  |  |  |
| 7                            | Base – Condenser       | GS                       | 2A1217-01   | 1               | 1      |  |  |  |  |  |  |
| 8                            | Threaded Insert        | -                        | 4A0407-01   | 5               | 5      |  |  |  |  |  |  |
| 9                            | Retainer – Filter      | -                        | 4A2138-01   | 1               | 1      |  |  |  |  |  |  |
| 9a                           | T2 Screw               | 4x8, SS                  | 7P32-0408   | 2               | 2      |  |  |  |  |  |  |
| 10                           | Capacitor              | -                        | 443192-02   | 1               | 1      |  |  |  |  |  |  |
| 10a                          | T2 Screw               | 4X8, SS                  | 7P32-0408   | 1               | 1      |  |  |  |  |  |  |

# J. Body-Prefinal FH1-AAC(-HD)

K-0, L-0, L-5, M-5, M-6, M-7, N-5, N-6, P-5, P-6, P-7, P-8, Q-5, Q-6

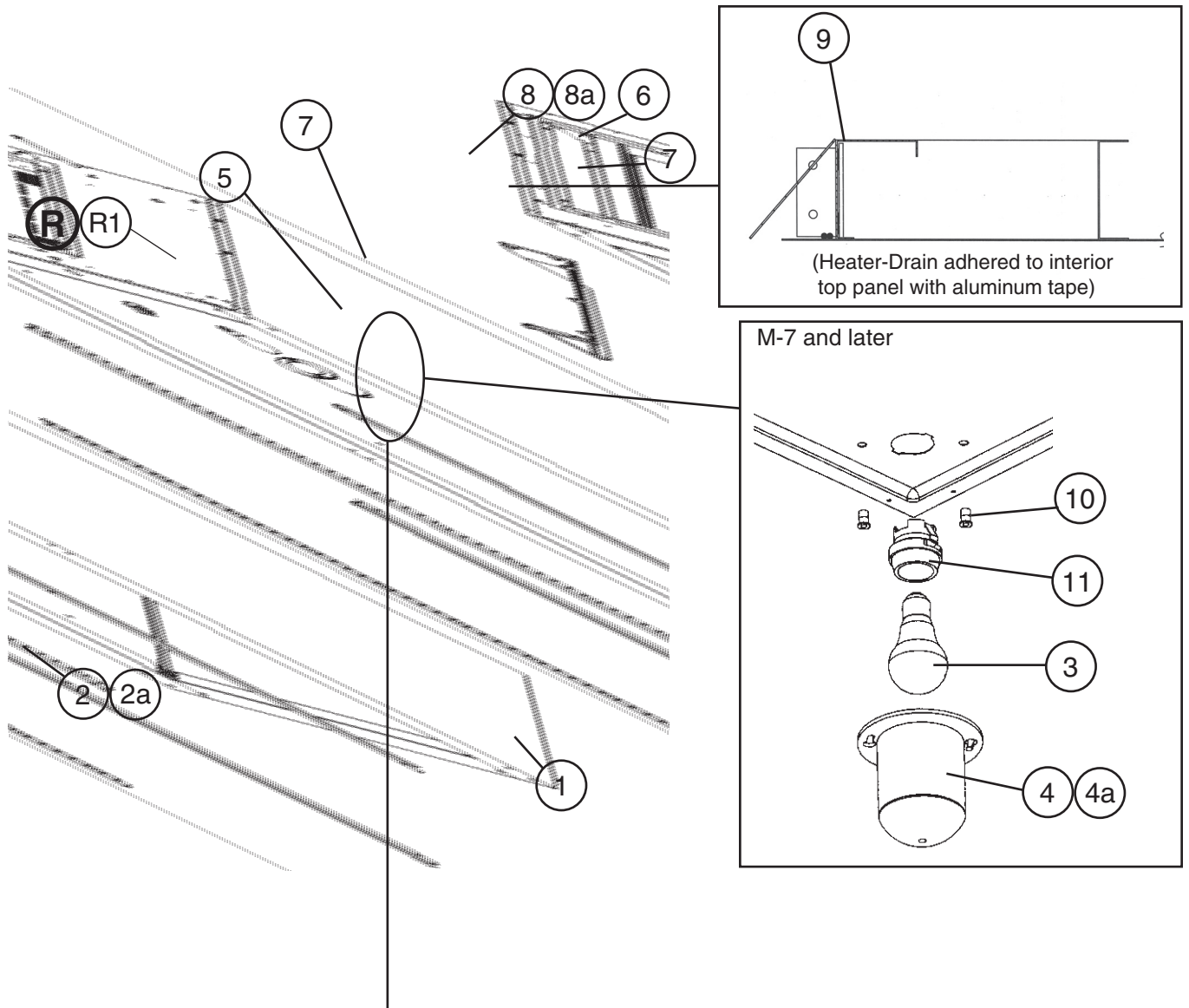

## M-6 and earlier

The santoprene light socket was changed to a porcelain lampholder at M-7. This change is non-interchangeable. If the light socket is not operating on a unit with a santoprene light socket, Hoshizaki recommends replacement with HS-3554.

### Note:

Parts 3, 4, 4a, 4b and 4c are not included in HS-3554; they are shown for reference only.

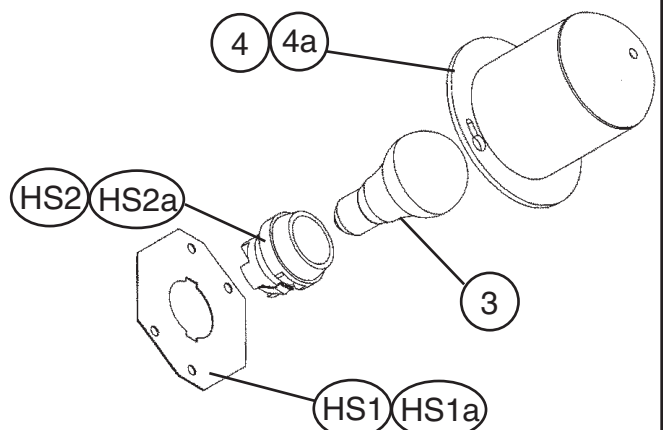

| Title: <b>J. Body-Prefinal</b> Model: <b>FH1-AAC(-HD)</b> |                            |                               |             |                 |            |            |  |  |  |  |  |  |
|---|----------------------------|-------------------------------|-------------|-----------------|------------|------------|--|--|--|--|--|--|
| Index No.   | Description                | Material or Model Number      | Part Number | Required Number |            |            |  |  |  |  |  |  |
|   |                            |                               |             | K-0 to M-6      | M-7 to P-5 | P-6 to Q-6 |  |  |  |  |  |  |
| R   | Distributor – Air Top Assm |                               | 2A0438G01   | 1               | 1          | -          |  |  |  |  |  |  |
|   |                            |                               | 2A3086A01   |                 |            | 1          |  |  |  |  |  |  |
| R1  | T2 Screw                   | 4x8, SS                       | 7P32-0408   | 7               | 7          | 7          |  |  |  |  |  |  |
| 1   | Cabinet Prefoam            | <b>FH1-AAC</b>                | 1A0173G04   | 1               | 1          | 1          |  |  |  |  |  |  |
|   |                            | <b>FH1-AAC-HD</b>             | 1A0353G03   | 1               | 1          | 1          |  |  |  |  |  |  |
| 2   | Pilaster                   | AL                            | 3A0145-21   | 4               | 4          | 4          |  |  |  |  |  |  |
| 2a  | Truss Head Screw           | 5x10, SS                      | 7C32-0510   | 12              | 12         | 12         |  |  |  |  |  |  |
| 3   | Bulb – Light               | -                             | 4A0437-01   | 1               | -          |            |  |  |  |  |  |  |
|   |                            | -                             | 4A2420-01   |                 | 1          | 1          |  |  |  |  |  |  |
| 4   | Shield – Light             | STANDARD KEIL, 2778-1010-3000 | 4A0465-01   | 1               | 1          | 1          |  |  |  |  |  |  |
| 4a  | Cheese Head Screw          | 5x12, SS                      | 7C52-0512   | 2               | 2          | 2          |  |  |  |  |  |  |
| 4b  | Washer                     | 8, SS                         | 7W22-0800   | 2               | -          |            |  |  |  |  |  |  |
| 5   | Switch – Door              | NYLON                         | 3A1826-01   | 1               | 1          | 1          |  |  |  |  |  |  |
| 6   | Vinyl Hose                 | L=1700                        | 7730I3812   | 1               | 1          | 1          |  |  |  |  |  |  |
| 7   | Bushing                    | OCB-875                       | 428394-04   | 2               | 2          | 2          |  |  |  |  |  |  |
| 8   | Divider – Air              | AL                            | 2A0199-21   | 1               | 1          | 1          |  |  |  |  |  |  |
| 8a  | T2 Screw                   | 4x8, SS                       | 7P32-0408   | 4               | 4          | 4          |  |  |  |  |  |  |
| 9   | Heater – Drain             | 10758 25W115V                 | 4A2975-03   |                 |            | 1          |  |  |  |  |  |  |
| 10  | Threaded Insert (Wide)     |                               | 4A0839-01   |                 | 2          | 2          |  |  |  |  |  |  |
| 11  | Lampholder                 | -                             | 4A2862-01   |                 | 1          | 1          |  |  |  |  |  |  |

Non-interchangeable part change. If light socket is not operating for these codes, Hoshizaki recommends replacement with HS-3554 (below).

| HS-3554-Lampholder Conversion Kit |                          |                          |             |                 |  |  |  |  |  |  |  |  |
|-----------------------------------|--------------------------|--------------------------|-------------|-----------------|--|--|--|--|--|--|--|--|
| Index No.                         | Description              | Material or Model Number | Part Number | Required Number |  |  |  |  |  |  |  |  |
|                                   |                          |                          |             | M-6 and earlier |  |  |  |  |  |  |  |  |
| HS1                               | Plate – Lampholder Mount | SS                       | 4A2880-01   | 1               |  |  |  |  |  |  |  |  |
| HS1a                              | Cheese Head Screw        | SS                       | 7C52-0512   | 2               |  |  |  |  |  |  |  |  |
| HS2                               | Lampholder               |                          | 4A2862-01   | 1               |  |  |  |  |  |  |  |  |
| HS2a                              | Terminal – Flag          | DNFR18-250FIBK           | 8101-18FJ   | 2               |  |  |  |  |  |  |  |  |

# J. Body-Prefinal FH2-AAC(-HD)

K-0, L-5, M-5, M-6, M-7, M-8, N-5, N-6, P-5, P-6, P-7, P-8, Q-5, Q-6

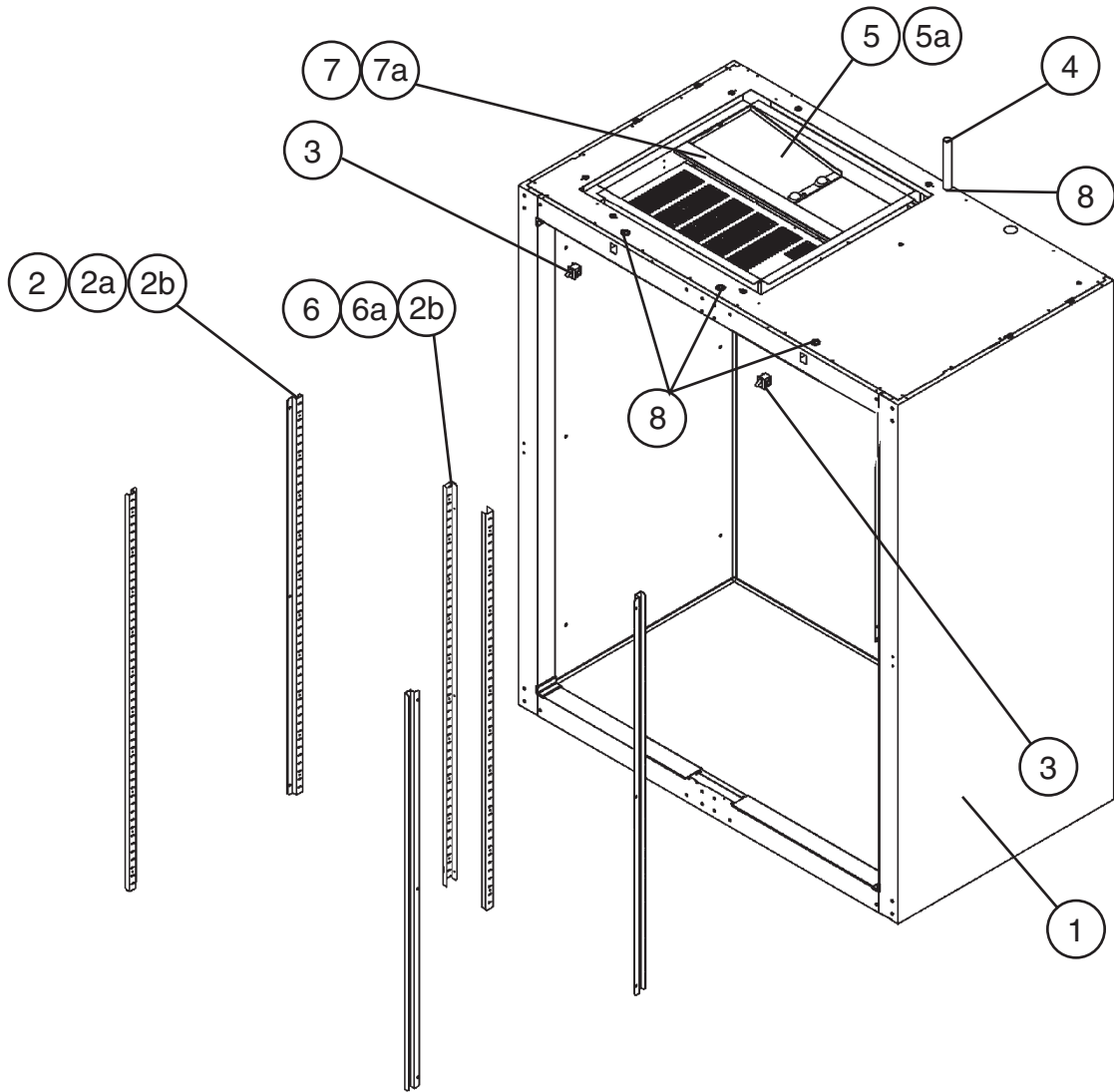

| Title: <b>J. Body-Prefinal</b> Model: <b>FH2-AAC(-HD)</b> |                    |                          |             |                 |            |  |  |  |  |  |  |
|---|--------------------|--------------------------|-------------|-----------------|------------|--|--|--|--|--|--|
| Index No.   | Description        | Material or Model Number | Part Number | Required Number |            |  |  |  |  |  |  |
|   |                    |                          |             | K-0 to P-6      | P-7 to Q-6 |  |  |  |  |  |  |
| 1   | Cabinet – Prefoam  | -                        | 2A0706G05   | 1               | 1          |  |  |  |  |  |  |
| 2   | Pilaster           | AL                       | 3A0145-21   | 4               | 4          |  |  |  |  |  |  |
| 2a  | Truss Head Screw   | 5×10, SS                 | 7C32-0510   | 12              | 12         |  |  |  |  |  |  |
| 2b  | Threaded Insert    | M5                       | 4A0407-01   | 18              | 18         |  |  |  |  |  |  |
| 3   | Switch – Door      | NYLON                    | 3A1826-01   | 2               | 2          |  |  |  |  |  |  |
| 4   | Vinyl Hose         | L=1700                   | 7730I3812   | 1               | 1          |  |  |  |  |  |  |
| 5   | Baffle – Air       | -                        | 2A0625-01   | 1               | 1          |  |  |  |  |  |  |
| 5a  | Truss Head Screw   | 5×10, SS                 | 7C32-0510   | 2               | 2          |  |  |  |  |  |  |
| 6   | Pilaster – Mullion | AL                       | 2A0205-21   | 2               | -          |  |  |  |  |  |  |
|   |                    |                          | 2A3246-21   |                 | 2          |  |  |  |  |  |  |
| 6a  | Truss Head Screw   | 5×10, SS                 | 7C32-0510   | 6               | 6          |  |  |  |  |  |  |
| 7   | Divider – Air      | AL                       | 2A0199-21   | 1               | 1          |  |  |  |  |  |  |
| 7a  | T2 Screw           | 4×8, SS                  | 7P32-0408   | 4               | 4          |  |  |  |  |  |  |
| 8   | Bushing            | OCB-875                  | 428394-04   | 4               | 4          |  |  |  |  |  |  |



## K. Door-Right

### FH1-AAC, FH2-AAC

K-0, L-5, M-5, M-6, M-7, M-8, N-5, N-6, P-5, P-6, P-7, P-8, Q-5, Q-6

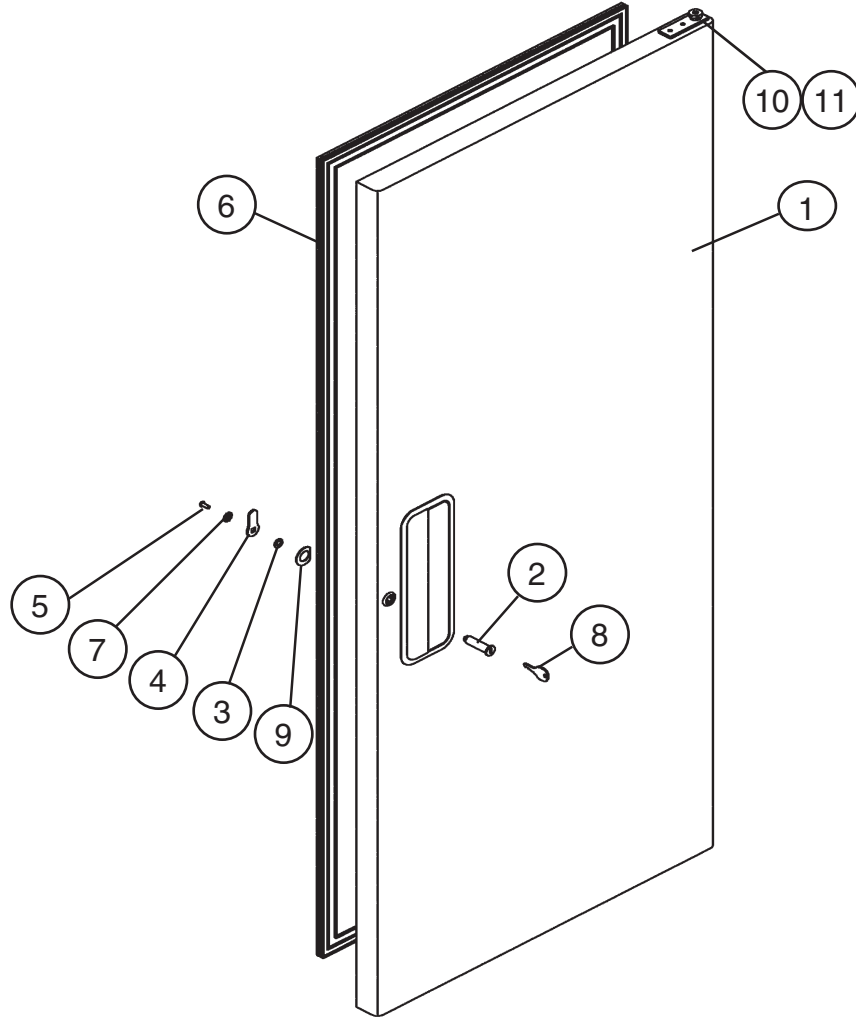

| Title: K. Door-Right Model: FH1-AAC, FH2-AAC |                     |                             |             |            | Required Number |  |  |  |  |  |  |  |  |
|--|---------------------|-----------------------------|-------------|------------|-----------------|--|--|--|--|--|--|--|--|
| Index No.                                    | Description         | Material or Model Number    | Part Number | K-0 to Q-6 |                 |  |  |  |  |  |  |  |  |
| 1  | Door – Prefoam (R)  | -                           | 1A0317G03   | 1          |                 |  |  |  |  |  |  |  |  |
| 2  | Lock – Tumbler      | M4-5813-001                 | 4A0462-01   | 1          |                 |  |  |  |  |  |  |  |  |
| 3  | Lock – Stop Washer  | M5-8060-103                 | 4A0458-01   | 1          |                 |  |  |  |  |  |  |  |  |
| 4  | Cam – Door Lock     | P.S                         | 4A0228-01   | 1          |                 |  |  |  |  |  |  |  |  |
| 5  | Lock – Screw        | SS                          | 4A0461-01   | 1          |                 |  |  |  |  |  |  |  |  |
| 6  | Gasket – Door       | Jarrow #P-2209<br>244A GRAY | 3A0273-01   | 1          |                 |  |  |  |  |  |  |  |  |
| 7  | Lock Washer         | SS                          | 4A0459-01   | 1          |                 |  |  |  |  |  |  |  |  |
| 8  | Lock – Key          | M5-0680-111                 | 4A0460-01   | 1          |                 |  |  |  |  |  |  |  |  |
| 9  | Washer – Door Lock  | SS                          | 4A0670-01   | 1          |                 |  |  |  |  |  |  |  |  |
| 10   | Hinge – Spring      |                             | 4A3312-01   | 1          |                 |  |  |  |  |  |  |  |  |
| 11   | Hinge – Spring Cart |                             | 4A0438-01   | 1          |                 |  |  |  |  |  |  |  |  |

**L. Door-Left  
FH2-AAC**

L-5, M-5, M-6, M-7, M-8, N-5, N-6, P-5, P-6, P-7, Q-5, Q-6

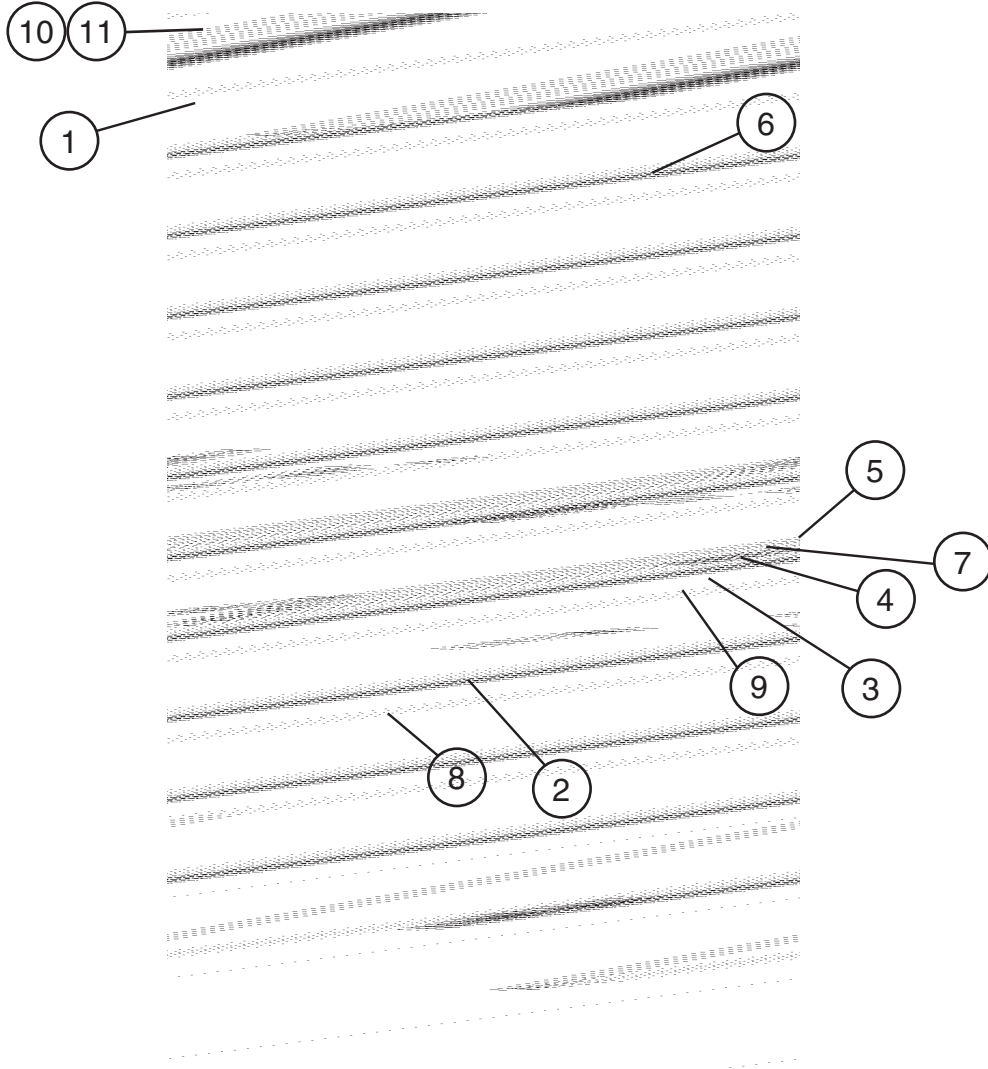

| Title: L. Door-Left |                     | Model: FH2-AAC                 |             | Required Number |                    |   |           |   |  |  |  |  |  |  |
|---------------------|---------------------|--------------------------------|-------------|-----------------|--------------------|---|-----------|---|--|--|--|--|--|--|
| Index No.           | Description         | Material or Model Number       | Part Number | L-5 to Q-6      |                    |   |           |   |  |  |  |  |  |  |
|                     |                     |                                |             | 1               | Door – Prefoam (L) | - | 1A0317G04 | 1 |  |  |  |  |  |  |
| 2                   | Lock – Tumbler      | M4-5813-001                    | 4A0462-01   | 1               |                    |   |           |   |  |  |  |  |  |  |
| 3                   | Lock – Stop Washer  | M5-8060-103                    | 4A0458-01   | 1               |                    |   |           |   |  |  |  |  |  |  |
| 4                   | Cam – Door Lock     | P.S                            | 4A0228-01   | 1               |                    |   |           |   |  |  |  |  |  |  |
| 5                   | Lock – Screw        | SS                             | 4A0461-01   | 1               |                    |   |           |   |  |  |  |  |  |  |
| 6                   | Gasket – Door       | JARROW<br>#P-2209<br>244A GRAY | 3A0273-01   | 1               |                    |   |           |   |  |  |  |  |  |  |
| 7                   | Lock Washer         | SS                             | 4A0459-01   | 1               |                    |   |           |   |  |  |  |  |  |  |
| 8                   | Lock – Key          | M5-0680-111                    | 4A0460-01   | 1               |                    |   |           |   |  |  |  |  |  |  |
| 9                   | Washer – Door Lock  | SS                             | 4A0670-01   | 1               |                    |   |           |   |  |  |  |  |  |  |
| 10                  | Hinge – Spring      |                                | 4A3312-02   | 1               |                    |   |           |   |  |  |  |  |  |  |
| 11                  | Hinge – Spring Cart |                                | 4A0438-02   | 1               |                    |   |           |   |  |  |  |  |  |  |

**M. Door-Half (UR)**

**FH1-AAC-HD, FH2-AAC-HD**

K-0, L-0, L-5, M-5, M-6, M-7, N-6, P-5, P-6, P-7, P-8, Q-5, Q-6

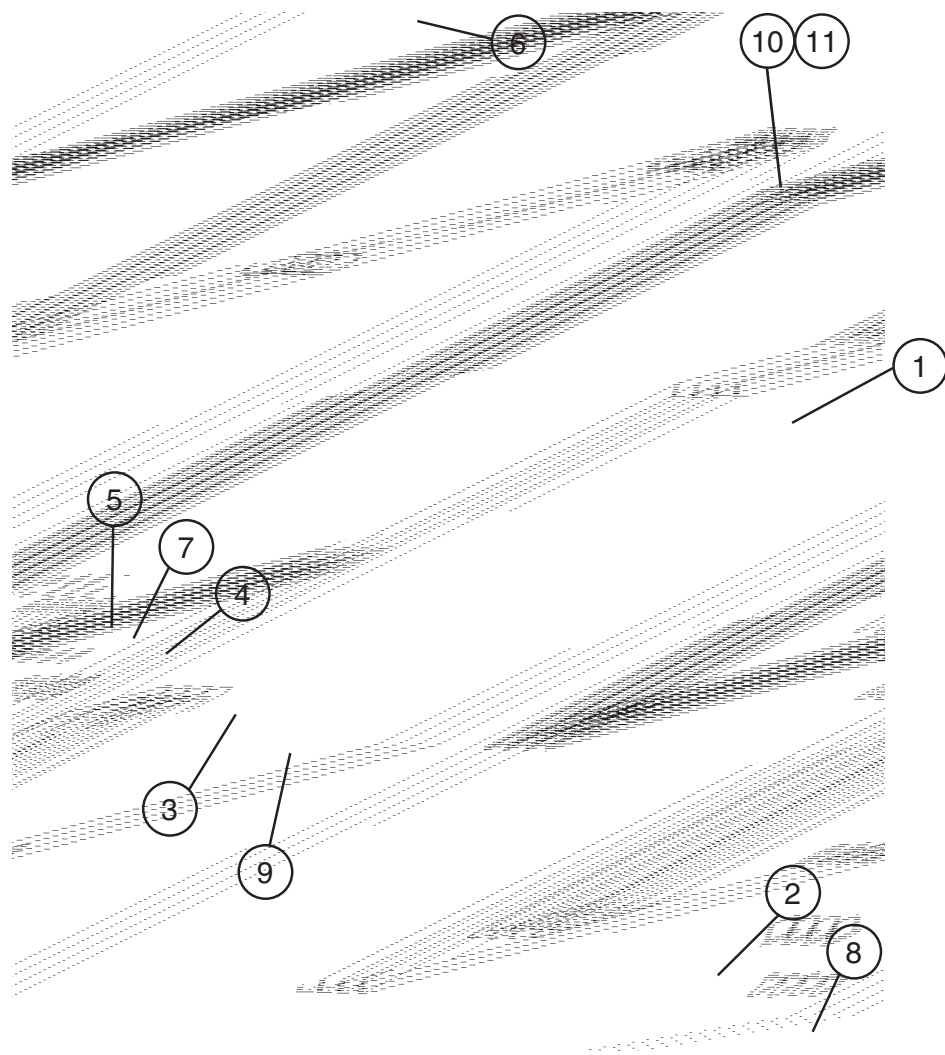

| Title: <b>M. Door-Half (UR)</b> Model: <b>FH1-AAC-HD, FH2-AAC-HD</b> |                      |                          |             |                 |  |  |  |  |  |  |
|--|----------------------|--------------------------|-------------|-----------------|--|--|--|--|--|--|
| Index No.  | Description          | Material or Model Number | Part Number | Required Number |  |  |  |  |  |  |
|  |                      |                          |             | K-0 to Q-6      |  |  |  |  |  |  |
| 1  | Door – Prefoam (UR)  | -                        | 1A0325G03   | 1               |  |  |  |  |  |  |
| 2  | Lock – Tumbler       | M4-5813-001              | 4A0462-01   | 1               |  |  |  |  |  |  |
| 3  | Lock – Stop Washer   | M5-8060-103              | 4A0458-01   | 1               |  |  |  |  |  |  |
| 4  | Cam – Door Lock      | P.S                      | 4A0228-01   | 1               |  |  |  |  |  |  |
| 5  | Lock – Screw         | SS                       | 4A0461-01   | 1               |  |  |  |  |  |  |
| 6  | Gasket – Door (Half) | JARROW #P-2209 244A GRAY | 3A0273-02   | 1               |  |  |  |  |  |  |
| 7  | Lock Washer          | SS                       | 4A0459-01   | 1               |  |  |  |  |  |  |
| 8  | Lock – Key           | M5-0680-111              | 4A0460-01   | 1               |  |  |  |  |  |  |
| 9  | Washer – Door Lock   | SS                       | 4A0670-01   | 1               |  |  |  |  |  |  |
| 10   | Hinge – Spring       |                          | 4A3312-01   | 1               |  |  |  |  |  |  |
| 11   | Hinge – Spring Cart  |                          | 4A0438-01   | 1               |  |  |  |  |  |  |

# N. Door-Half (LR)

## FH1-AAC-HD, FH2-AAC-HD

K-0, L-0, L-5, M-5, M-6, M-7, N-6, P-5, P-6, P-7, P-8, Q-5, Q-6

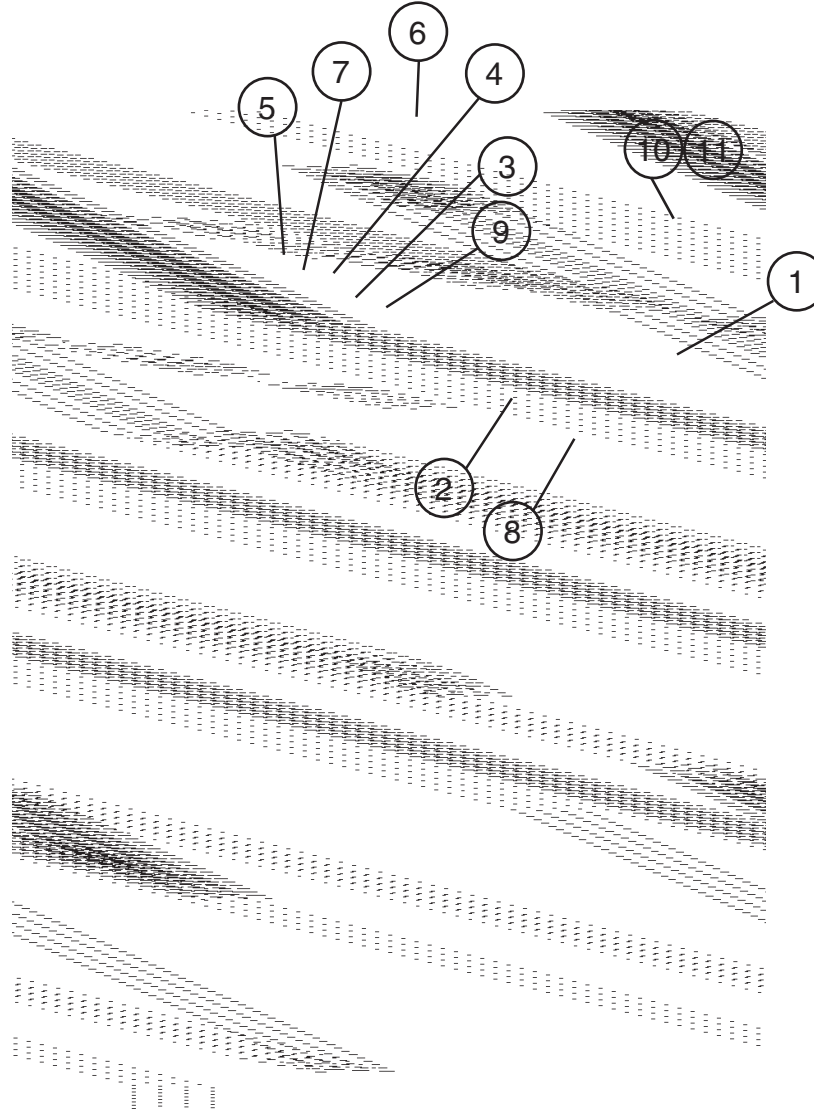

| Title: N. Door Half (LR) Model: FH1-AAC-HD, FH2-AAC-HD |                      |                            |             | Required Number |  |  |  |  |  |  |  |  |
|--|----------------------|----------------------------|-------------|-----------------|--|--|--|--|--|--|--|--|
| Index No.  | Description          | Material or Model Number   | Part Number | K-0 to Q-6      |  |  |  |  |  |  |  |  |
| 1  | Door – Prefoam (LR)  | -                          | 1A0323G03   | 1               |  |  |  |  |  |  |  |  |
| 2  | Lock – Tumbler       | M4-5813-001                | 4A0462-01   | 1               |  |  |  |  |  |  |  |  |
| 3  | Lock – Stop Washer   | M5-8060-103                | 4A0458-01   | 1               |  |  |  |  |  |  |  |  |
| 4  | Cam – Door Lock      | P.S                        | 4A0228-01   | 1               |  |  |  |  |  |  |  |  |
| 5  | Lock – Screw         | SS                         | 4A0461-01   | 1               |  |  |  |  |  |  |  |  |
| 6  | Gasket – Door (Half) | JARROW P-2209<br>244A GRAY | 3A0273-02   | 1               |  |  |  |  |  |  |  |  |
| 7  | Lock Washer          | SS                         | 4A0459-01   | 1               |  |  |  |  |  |  |  |  |
| 8  | Lock – Key           | M5-0680-111                | 4A0460-01   | 1               |  |  |  |  |  |  |  |  |
| 9  | Washer – Door Lock   | SS                         | 4A0670-01   | 1               |  |  |  |  |  |  |  |  |
| 10   | Hinge – Spring       |                            | 4A3312-01   | 1               |  |  |  |  |  |  |  |  |
| 11   | Hinge – Spring Cart  |                            | 4A0438-01   | 1               |  |  |  |  |  |  |  |  |

**P. Door-Half (UL)  
FH2-AAC-HD**

K-0, L-5, M-6, N-6, P-5, P-6, P-7, P-8, Q-5, Q-6

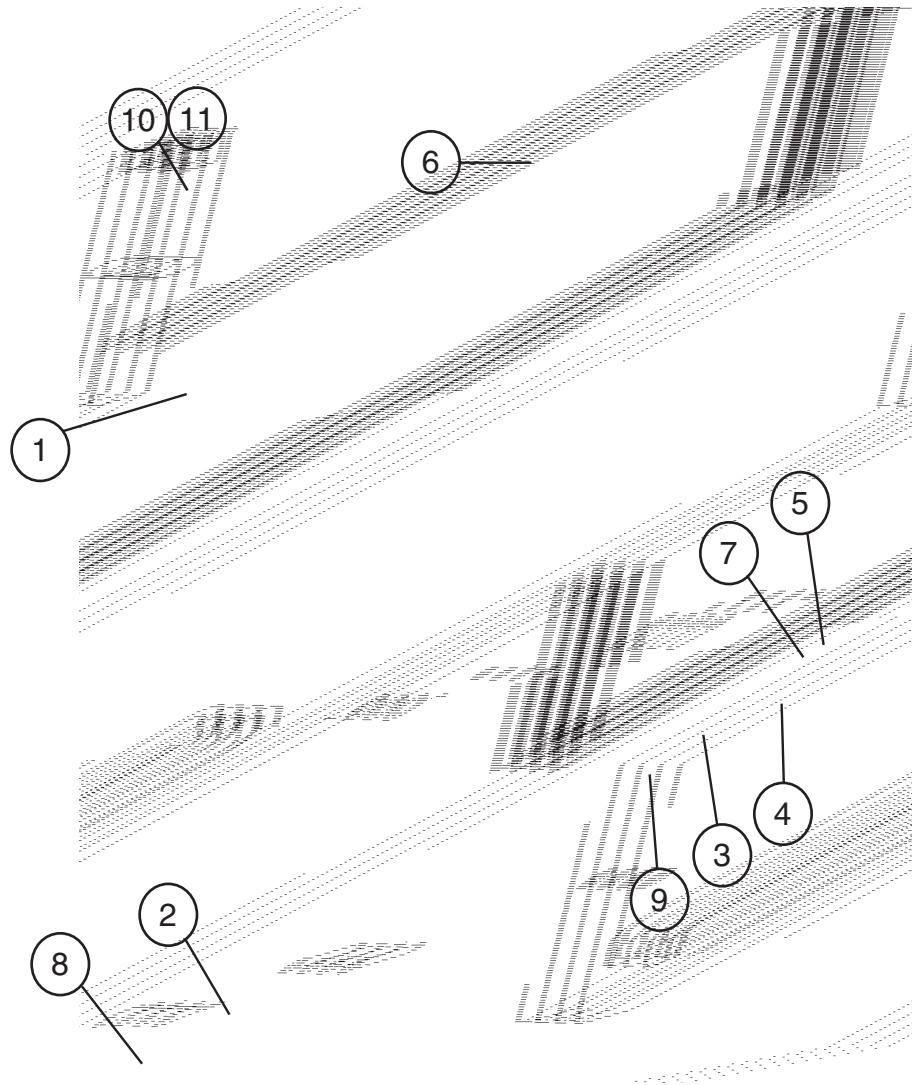

| Title: <b>P. Door-Half (UL)</b> Model: <b>FH2-AAC-HD</b> |                      |                             |             |                 |  |  |  |  |  |  |
|--|----------------------|-----------------------------|-------------|-----------------|--|--|--|--|--|--|
| Index No.  | Description          | Material or Model Number    | Part Number | Required Number |  |  |  |  |  |  |
|  |                      |                             |             | K-0 to Q-6      |  |  |  |  |  |  |
| 1  | Door – Prefoam (UL)  | -                           | 1A0323G04   | 1               |  |  |  |  |  |  |
| 2  | Lock – Tumbler       | M4-5813-001                 | 4A0462-01   | 1               |  |  |  |  |  |  |
| 3  | Lock – Stop Washer   | M5-8060-103                 | 4A0458-01   | 1               |  |  |  |  |  |  |
| 4  | Cam – Door Lock      | P.S                         | 4A0228-01   | 1               |  |  |  |  |  |  |
| 5  | Lock – Screw         | SS                          | 4A0461-01   | 1               |  |  |  |  |  |  |
| 6  | Gasket – Door (Half) | Jarrow #P-2209<br>244A GRAY | 3A0273-02   | 1               |  |  |  |  |  |  |
| 7  | Lock Washer          | SS                          | 4A0459-01   | 1               |  |  |  |  |  |  |
| 8  | Lock – Key           | M5-0680-111                 | 4A0460-01   | 1               |  |  |  |  |  |  |
| 9  | Washer – Door Lock   | SS                          | 4A0670-01   | 1               |  |  |  |  |  |  |
| 10   | Hinge – Spring       |                             | 4A3312-02   | 1               |  |  |  |  |  |  |
| 11   | Hinge – Spring Cart  |                             | 4A0438-02   | 1               |  |  |  |  |  |  |

**Q. Door-Half (LL)**  
**FH2-AAC-HD**

K-0, L-5, M-6, N-6, P-5, P-6, P-7, P-8, Q-5, Q-6

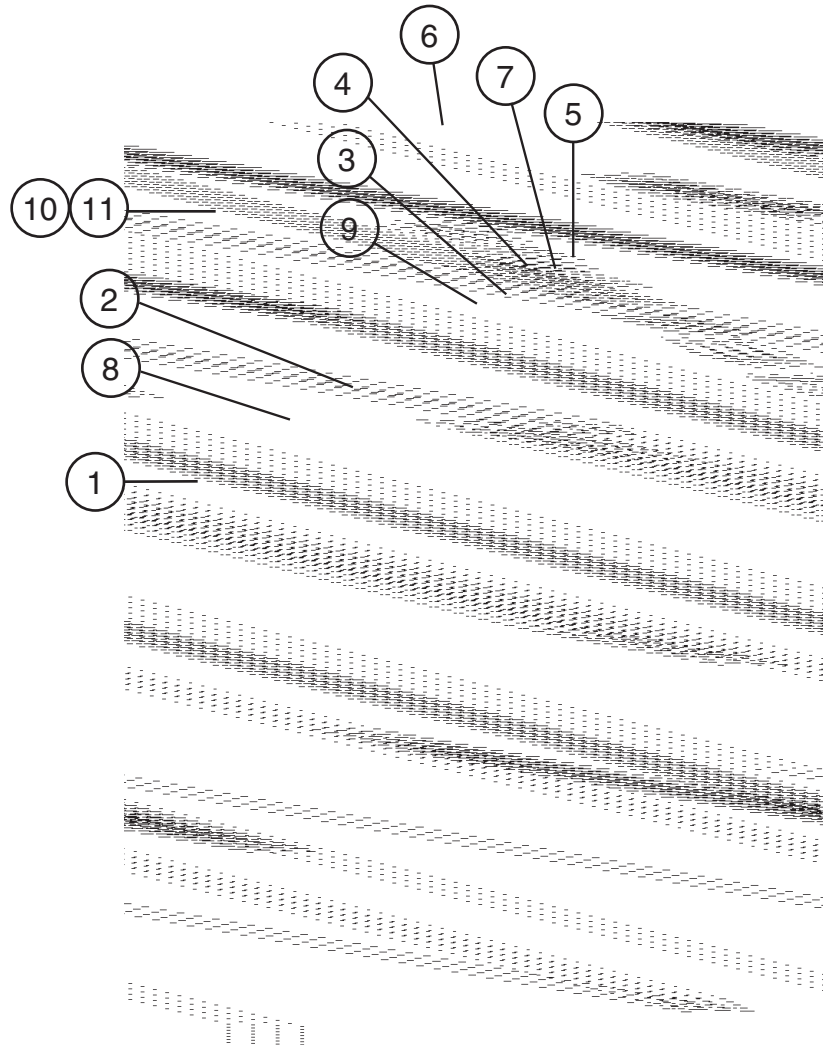

| Title: <b>Q. Door-Half (LL)</b> Model: <b>FH2-AAC-HD</b> |                      |                             |             |                 |  |  |  |  |  |  |
|--|----------------------|-----------------------------|-------------|-----------------|--|--|--|--|--|--|
| Index No.  | Description          | Material or Model Number    | Part Number | Required Number |  |  |  |  |  |  |
|  |                      |                             |             | K-0 to Q-6      |  |  |  |  |  |  |
| 1  | Door – Prefoam (LL)  | -                           | 1A0325G04   | 1               |  |  |  |  |  |  |
| 2  | Lock – Tumbler       | M4-5813-001                 | 4A0462-01   | 1               |  |  |  |  |  |  |
| 3  | Lock – Stop Washer   | M5-8060-103                 | 4A0458-01   | 1               |  |  |  |  |  |  |
| 4  | Cam – Door Lock      | P.S                         | 4A0228-01   | 1               |  |  |  |  |  |  |
| 5  | Lock – Screw         | SS                          | 4A0461-01   | 1               |  |  |  |  |  |  |
| 6  | Gasket – Door (Half) | Jarrow #P-2209<br>244A GRAY | 3A0273-02   | 1               |  |  |  |  |  |  |
| 7  | Lock Washer          | SS                          | 4A0459-01   | 1               |  |  |  |  |  |  |
| 8  | Lock – Key           | M5-0680-111                 | 4A0460-01   | 1               |  |  |  |  |  |  |
| 9  | Washer – Door Lock   | SS                          | 4A0670-01   | 1               |  |  |  |  |  |  |
| 10   | Hinge – Spring       |                             | 4A3312-02   | 1               |  |  |  |  |  |  |
| 11   | Hinge – Spring Cart  |                             | 4A0438-02   | 1               |  |  |  |  |  |  |

## R. Distributor-Air Top Assembly

### FH1-AAC-(HD)

K-0, L-5, M-6, N-6, P-5, P-6, P-7, P-8, Q-5, Q-6

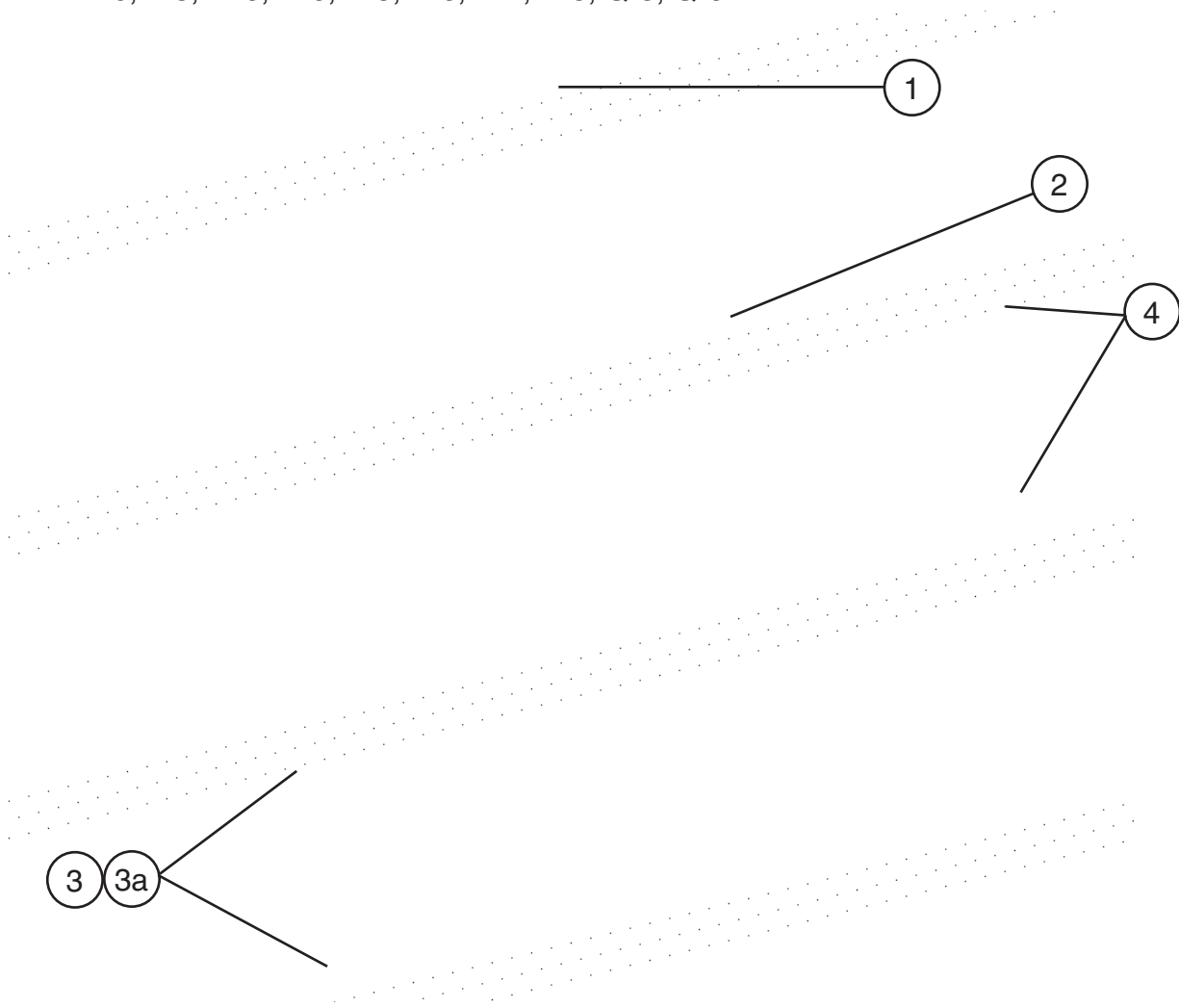

| Title: R. Distributor-Air Top Assembly Model: FH1-ACC-(HD) |                         |                          |             |                 |         |         |  |  |  |  |  |
|--|-------------------------|--------------------------|-------------|-----------------|---------|---------|--|--|--|--|--|
| Index No.  | Description             | Material or Model Number | Part Number | Required Number |         |         |  |  |  |  |  |
|  |                         |                          |             | K-0 to P-5      | P-6 P-7 | P-8 Q-6 |  |  |  |  |  |
| 1  | Distributor – Air (Top) | ABS                      | 2A0610-01   | 1               |         |         |  |  |  |  |  |
|  |                         |                          | 2A0610-03   |                 | 1       | -       |  |  |  |  |  |
|  |                         |                          | 2A0610-04   |                 |         | 1       |  |  |  |  |  |
| 2  | Shield – Duct           |                          | 2A3085-01   |                 | 1       | -       |  |  |  |  |  |
|  |                         |                          | 2A3392-01   |                 |         | 1       |  |  |  |  |  |
| 3  | Bracket – Heater Supply |                          | 3A3096G01   |                 | 1       | 1       |  |  |  |  |  |
| 3a   | Truss Head Screw        | 5x12                     | 7C32-0512   |                 | 4       | 6       |  |  |  |  |  |
| 4  | Heater – Glass Tube     |                          | 3A2335-02   |                 | 2       | 2       |  |  |  |  |  |

**S. Mullion-Horizontal**  
**FH1-AAC-HD**

K-0, L-0, L-5, M-5, M-6, M-7, N-6, P-5, P-6, Q-5, Q-6

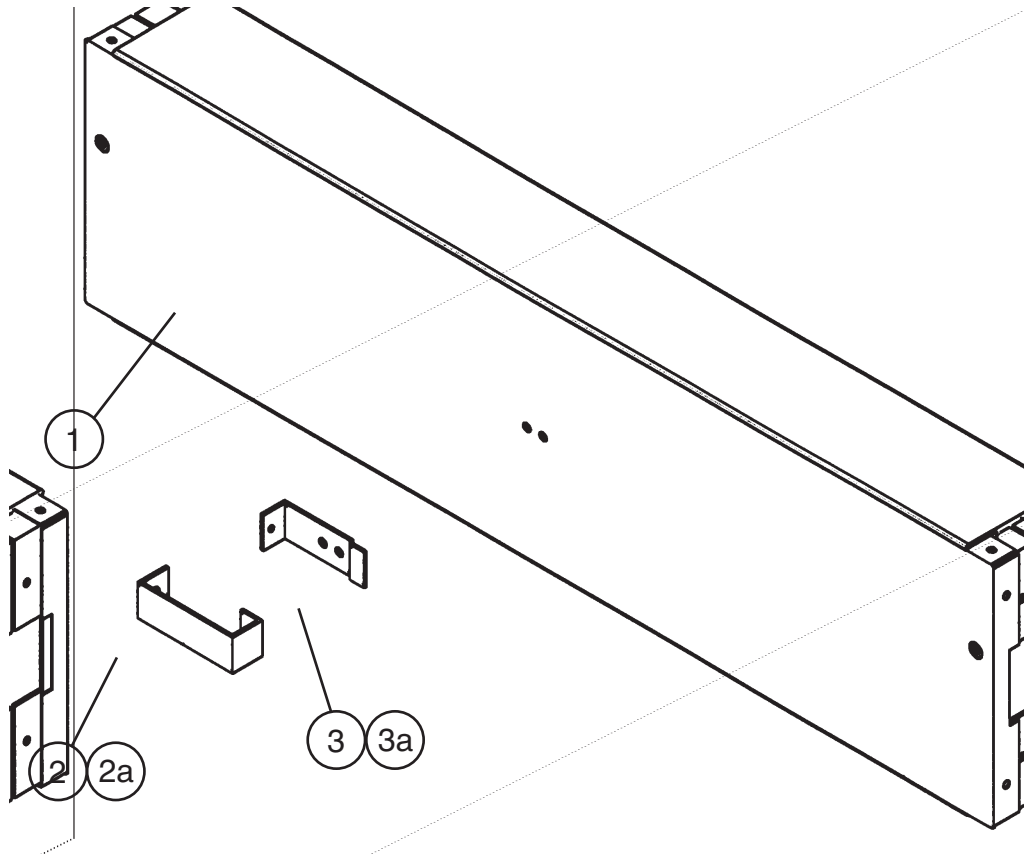

| Title: S. Mullion-Horizontal Model: FH1-AAC-HD |                        |                          |             |                 |  |  |  |  |  |  |
|--|------------------------|--------------------------|-------------|-----------------|--|--|--|--|--|--|
| Index No.                                      | Description            | Material or Model Number | Part Number | Required Number |  |  |  |  |  |  |
|  |                        |                          |             | K-0 to Q-6      |  |  |  |  |  |  |
| 1  | Mullion – Prefoam (H)  | -                        | 2A1313G03   | 1               |  |  |  |  |  |  |
| 2  | Plate – Strike (Front) | SS                       | 4A0355-01   | 1               |  |  |  |  |  |  |
| 2a   | Truss Head Screw       | 4x8, SS                  | 7C32--0408  | 1               |  |  |  |  |  |  |
| 3  | Plate – Strike (Base)  | SS                       | 4A0354-01   | 1               |  |  |  |  |  |  |
| 3a   | T2 Screw               | 4x8, SS                  | 7P32-0408   | 2               |  |  |  |  |  |  |



## T. Mullion-Vertical FH2-AAC

L-5, M-5, M-6, M-7, M-8, N-5, N-6, P-5, P-6, P-7, Q-5, Q-6

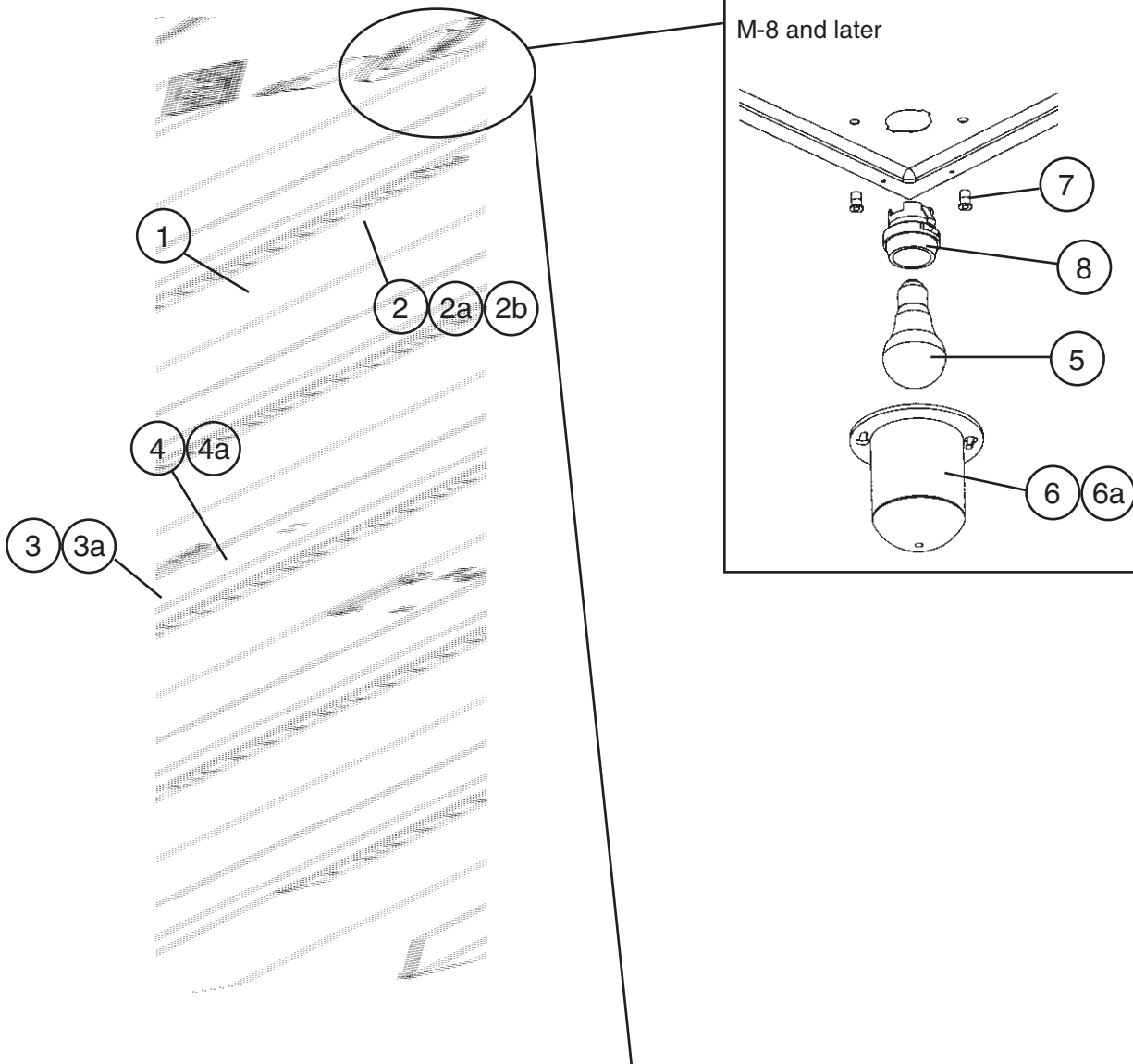

### M-7 and earlier

The santoprene light socket was changed to a porcelain lampholder at M-8. This change is non-interchangeable. If the light socket is not operating on a unit with a santoprene light socket, Hoshizaki recommends replacement with HS-3554.

#### Note:

Parts 5, 6, and 6a are not included in HS-3554; they are shown for reference only.

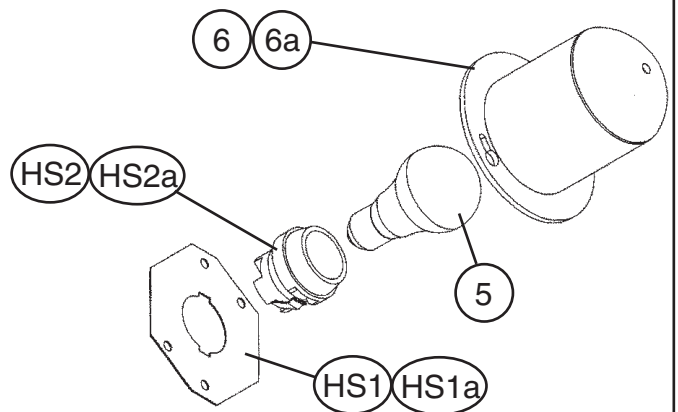

| Title: <b>T. Mullion-Vertical</b> Model: <b>FH2-AAC</b> |                        |                          |             |   |            |            |  |  |  |  |
|---|------------------------|--------------------------|-------------|---|------------|------------|--|--|--|--|
| Index No.   | Description            | Material or Model Number | Part Number | Required Number   |            |            |  |  |  |  |
|   |                        |                          |             | L-5 to M-7  | M-8 to P-6 | P-7 to Q-6 |  |  |  |  |
| 1   | Mullion – Prefoam      | -                        | 2A1288G04   | 1   | 1          | 1          |  |  |  |  |
| 2   | Pilaster – Mullion     | AL                       | 2A0205-21   | 2   | 2          | -          |  |  |  |  |
|   |                        |                          | 2A3246-21   |   |            | 2          |  |  |  |  |
| 2a  | Truss Head Screw       | 5x10, SS                 | 7C32-0510   | 6   | 6          | 6          |  |  |  |  |
| 2b  | Threaded Insert        |                          | 4A0407-01   | 6   | 6          | 6          |  |  |  |  |
| 3   | Plate – Strike (Front) | SS                       | 4A0355-01   | 1   | 1          | 1          |  |  |  |  |
| 3a  | Truss Head Screw       | 4x8, SS                  | 7C32-0408   | 1   | 1          | 1          |  |  |  |  |
| 4   | Plate – Strike (Base)  | SS                       | 4A0354-01   | 1   | 1          | 1          |  |  |  |  |
| 4a  | T2 Screw               | 4x8, SS                  | 7P32-0408   | 2   | 2          | 2          |  |  |  |  |
|   |                        |                          |             |   |            |            |  |  |  |  |
| 5   | Bulb – Light           | GE, 40A15                | 4A0437-01   | 1   | -          |            |  |  |  |  |
|   |                        | -                        | 4A2420-01   |   | 1          | 1          |  |  |  |  |
| 6   | Shield – Light         | 2778-1010-3000           | 4A0465-01   | 1   | 1          | 1          |  |  |  |  |
| 6a  | Cheese Head Screw      | 5x12, SS                 | 7C52-0512   | 2   | 2          | 2          |  |  |  |  |
| 6b  | Washer                 | 8, SS                    | 7W22-0800   | 2   | -          |            |  |  |  |  |
| 7   | Threaded Insert – Wide | -                        | 4A0839-01   | Non-interchangeable part change. If light socket is not operating for these codes, Hoshizaki recommends replacement with HS-3554 (below). | 1          | 1          |  |  |  |  |
| 8   | Lampholder             | -                        | 4A2862-01   |   | 1          | 1          |  |  |  |  |

| HS-3554-Lampholder Conversion Kit |                          |                          |             |                 |  |
|-----------------------------------|--------------------------|--------------------------|-------------|-----------------|--|
| Index No.                         | Description              | Material or Model Number | Part Number | Required Number |  |
|                                   |                          |                          |             | M-7 and earlier |  |
| HS1                               | Plate – Lampholder Mount | SS                       | 4A2880-01   | 1               |  |
| HS1a                              | Cheese Head Screw        | SS                       | 7C52-0512   | 2               |  |
| HS2                               | Lampholder               |                          | 4A2862-01   | 1               |  |
| HS2a                              | Terminal – Flag          | DNFR18-250FIBK           | 8101-18FJ   | 2               |  |

# U. Mullion-Cross FH2-AAC-HD

K-0, L-5, M-6, N-6, P-5, P-6, P-7, P-8, Q-5, Q-6

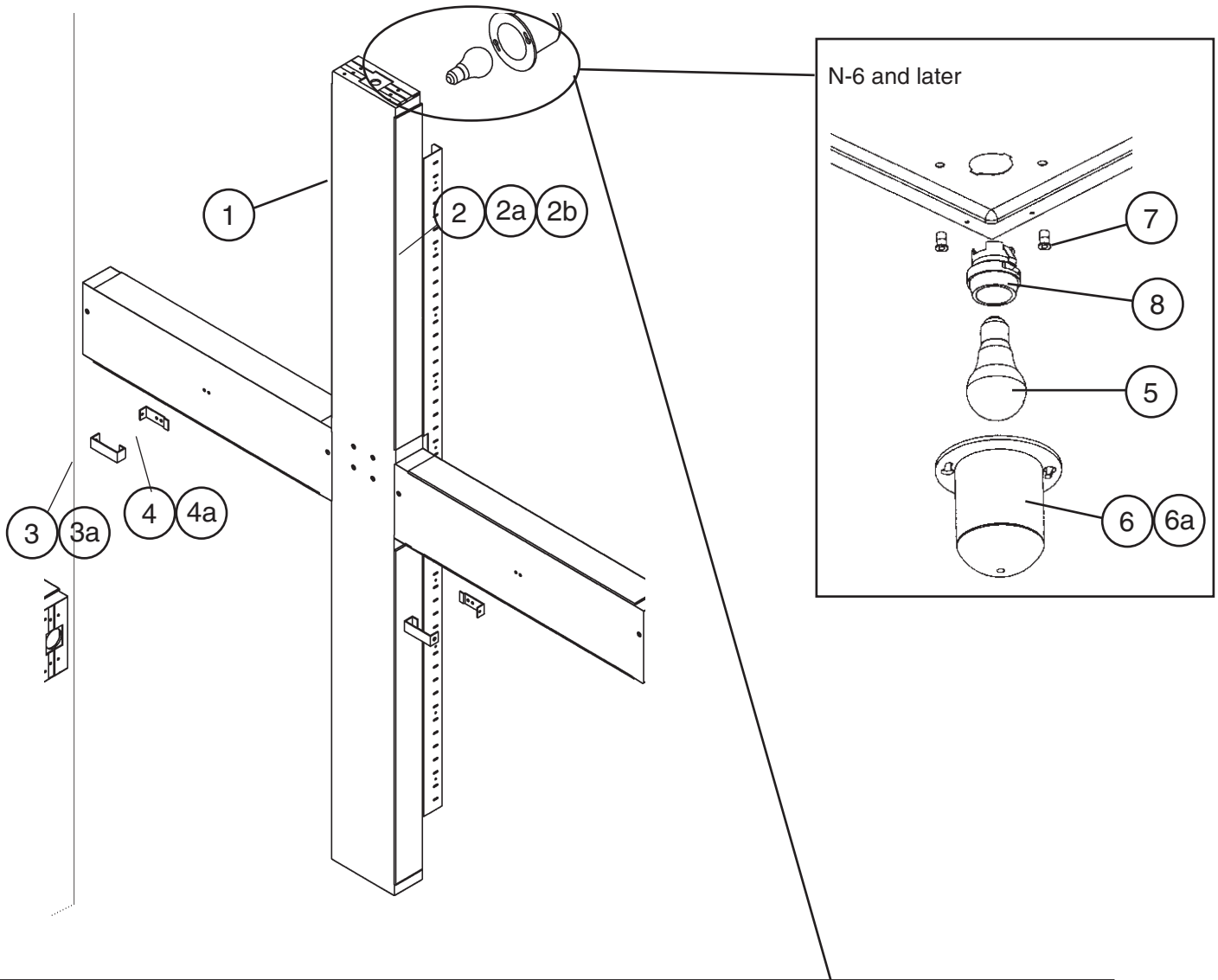

## M-6 and earlier

The santoprene light socket was changed to a porcelain lampholder at N-6. This change is non-interchangeable. If the light socket is not operating on a unit with a santoprene light socket, Hoshizaki recommends replacement with HS-3554.

### Note:

Parts 5, 6, and 6a are not included in HS-3554; they are shown for reference only.

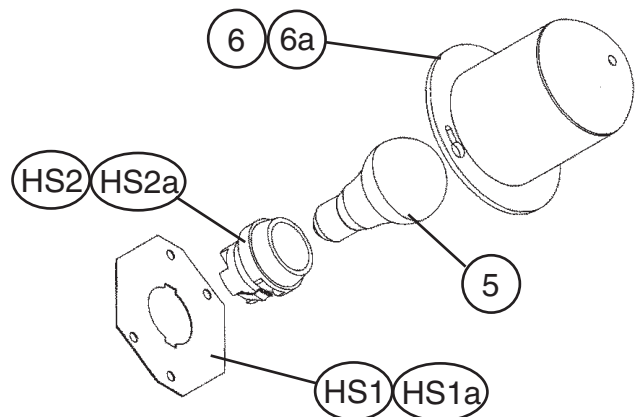

| Title: <b>U. Mullion-Cross</b> Model: <b>FH2-AAC-HD</b> |                        |                          |             |   |            |            |  |  |  |  |  |
|---|------------------------|--------------------------|-------------|---|------------|------------|--|--|--|--|--|
| Index No.   | Description            | Material or Model Number | Part Number | Required Number   |            |            |  |  |  |  |  |
|   |                        |                          |             | K-0 to M-6  | N-6 to P-7 | P-8 to Q-6 |  |  |  |  |  |
| 1   | Mullion – Prefoam      | -                        | 2A1288G03   | 1   | 1          | 1          |  |  |  |  |  |
| 2   | Pilaster – Mullion     | AL                       | 2A0205-21   | 2   | 2          | -          |  |  |  |  |  |
|   |                        |                          | 2A3246-21   |   |            | 2          |  |  |  |  |  |
| 2a  | Truss Head Screw       | 5x10, SS                 | 7C32-0510   | 6   | 6          | 6          |  |  |  |  |  |
| 2b  | Threaded Insert        |                          | 4A0407-01   | 6   | 6          | 6          |  |  |  |  |  |
| 3   | Plate – Strike (Front) | SS                       | 4A0355-01   | 1   | 1          | 1          |  |  |  |  |  |
| 3a  | Truss Head Screw       | 4x8, SS                  | 7C32-0408   | 1   | 1          | 1          |  |  |  |  |  |
| 4   | Plate – Strike (Base)  | SS                       | 4A0354-01   | 1   | 1          | 1          |  |  |  |  |  |
| 4a  | T2 Screw               | 4x8, SS                  | 7P32-0408   | 4   | 4          | 4          |  |  |  |  |  |
| 5   | Bulb – Light           | GE, 40A15                | 4A0437-01   | 1   | -          |            |  |  |  |  |  |
|   |                        | -                        | 4A2420-01   |   | 1          | 1          |  |  |  |  |  |
| 6   | Shield – Light         | 2778-1010-3000           | 4A0465-01   | 1   | 1          | 1          |  |  |  |  |  |
| 6a  | Cheese Head Screw      | 5x12, SS                 | 7C52-0512   | 2   | 2          | 2          |  |  |  |  |  |
| 6b  | Washer                 | 8, SS                    | 7W22-0800   | 2   | -          |            |  |  |  |  |  |
| 7   | Threaded Insert Wide   | -                        | 4A0839-01   | Non-interchangeable part change. If light socket is not operating for these codes, Hoshizaki recommends replacement with HS-3554 (below). | 6          | 6          |  |  |  |  |  |
| 8   | Lampholder             | -                        | 4A2862-01   |   | 1          | 1          |  |  |  |  |  |

| HS-3554-Lampholder Conversion Kit |                          |                          |             |                 |  |  |  |  |  |  |  |
|-----------------------------------|--------------------------|--------------------------|-------------|-----------------|--|--|--|--|--|--|--|
| Index No.                         | Description              | Material or Model Number | Part Number | Required Number |  |  |  |  |  |  |  |
|                                   |                          |                          |             | M-6 and earlier |  |  |  |  |  |  |  |
| HS1                               | Plate – Lampholder Mount | SS                       | 4A2880-01   | 1               |  |  |  |  |  |  |  |
| HS1a                              | Cheese Head Screw        | SS                       | 7C52-0512   | 2               |  |  |  |  |  |  |  |
| HS2                               | Lampholder               |                          | 4A2862-01   | 1               |  |  |  |  |  |  |  |
| HS2a                              | Terminal – Flag          | DNFR18-250FIBK           | 8101-18FJ   | 2               |  |  |  |  |  |  |  |

## V. Label Location FH1-AAC(-HD)

K-0, L-0, L-5, M-5, M-6, M-7, N-5, N-6, P-5, P-6, P-7, P-8, Q-5, Q-6

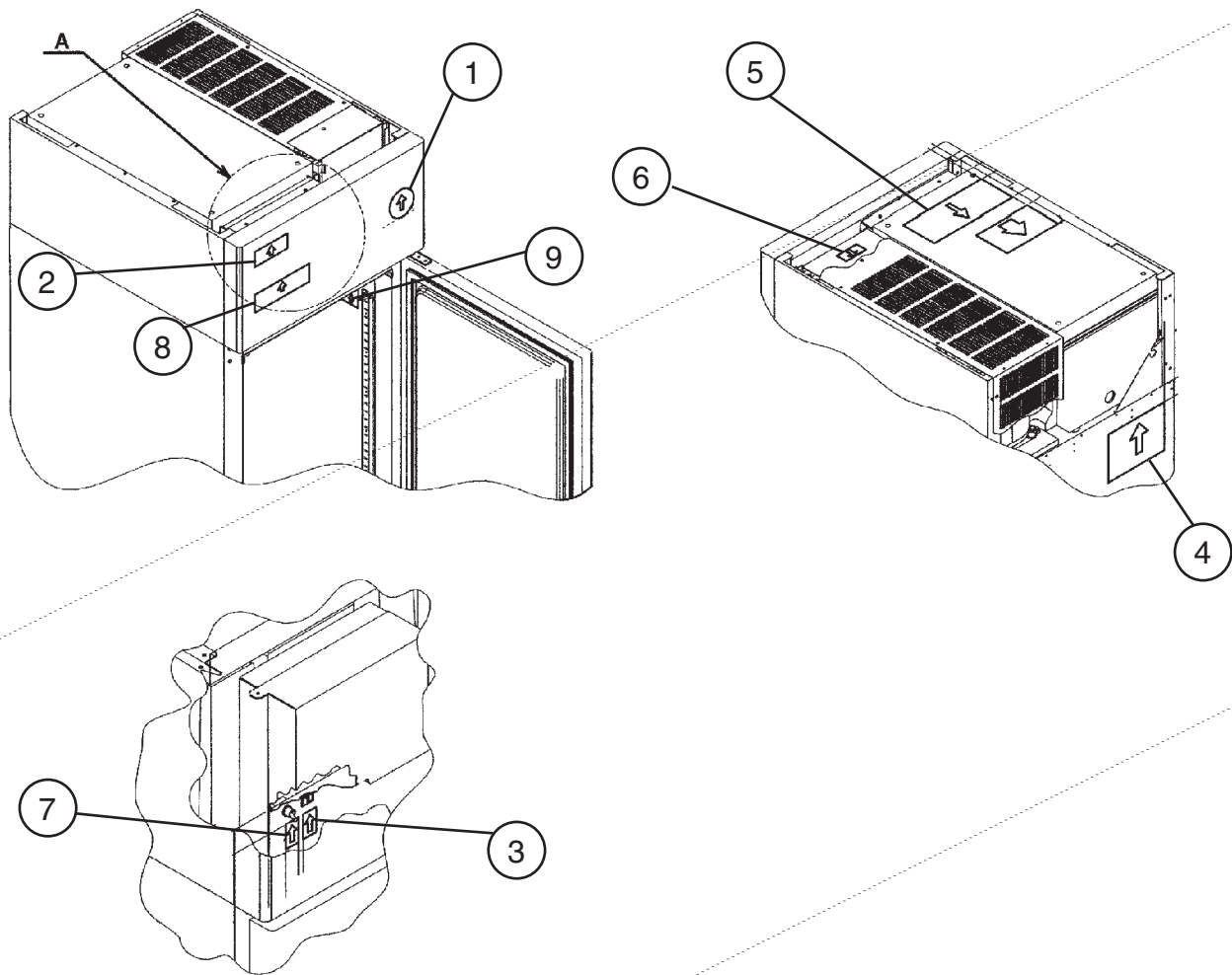

**VIEW A**

| Title: V. Label Location Model: FH1-AAC(-HD) |                            |                          |             | Required Number |        |        |        |  |  |  |  |  |  |
|--|----------------------------|--------------------------|-------------|-----------------|--------|--------|--------|--|--|--|--|--|--|
| Index No.                                    | Description                | Material or Model Number | Part Number | K-0             | M-5    | P-6    | Q-5    |  |  |  |  |  |  |
|  |                            |                          |             | L-5             | to P-5 | to P-8 | to Q-6 |  |  |  |  |  |  |
| 1  | Label – Penguin – HA(L)    | -                        | 4A0526-02   | 1               | 1      | 1      | 1      |  |  |  |  |  |  |
| 2  | Emblem – Hoshizaki         | -                        | 4A0560-01   | 1               | 1      | 1      | 1      |  |  |  |  |  |  |
| 3  | Label – Door Heater Switch | PVC Film                 | 4A1039-01   | 1               | 1      | 1      | 1      |  |  |  |  |  |  |
| 4  | Caution Label              | PVC Film                 | 4A1931-01   | 1               | 1      | 1      | 1      |  |  |  |  |  |  |
| 5  | Wiring Label               | PVC Film                 | 2A1934-01   | 1               | 1      | -      |        |  |  |  |  |  |  |
|  |                            |                          | 2A2340-01   |                 |        | 1      | 1      |  |  |  |  |  |  |
| 6  | Label – R404A              | -                        | 4A0960-01   | 1               | 1      | 1      | 1      |  |  |  |  |  |  |
| 7  | Label – Power              | -                        | 4A2196-01   | 1               | 1      | 1      | 1      |  |  |  |  |  |  |
| 8  | Label – Display            | -                        | 4A2286-01   | 1               | 1      | 1      | 1      |  |  |  |  |  |  |
| 9  | Cover – Nameplate          | -                        | 4A2265-01   |                 |        |        | 1      |  |  |  |  |  |  |

## V. Label Location FH2-AAC(-HD)

K-0, L-5, M-5, M-6, M-7, M-8, N-5, N-6, P-5, P-6, P-7, P-8, Q-5, Q-6

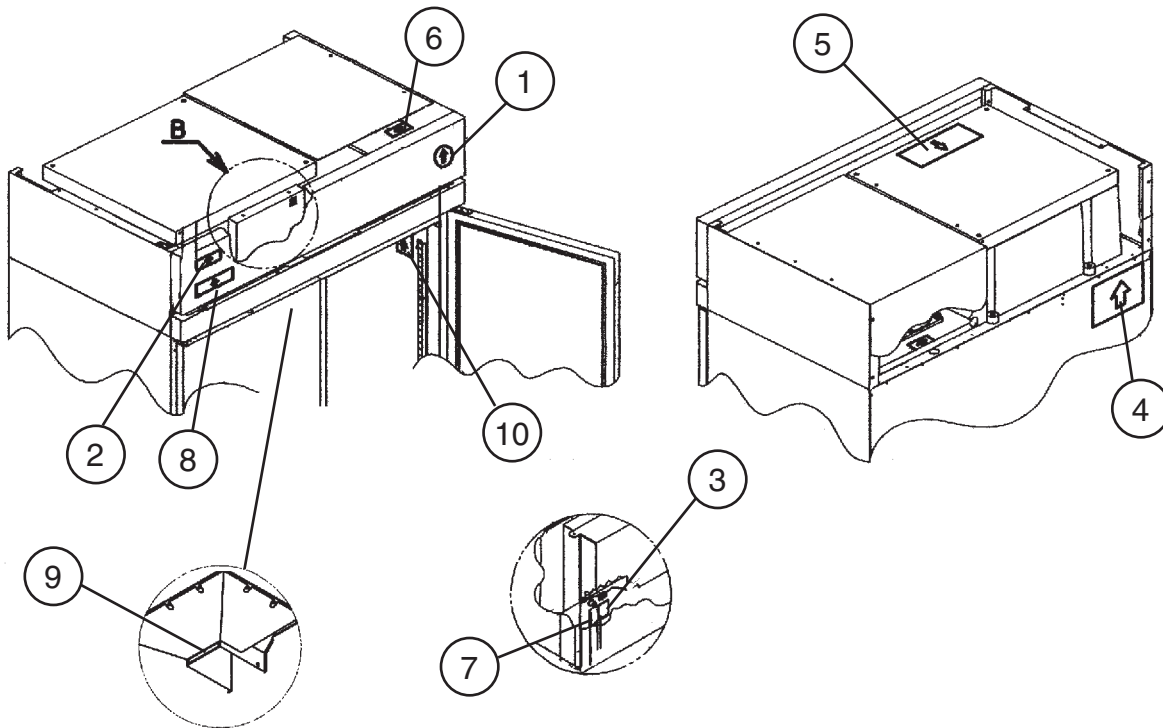

| Title: V. Label Location Model: FH2-AAC(-HD) |                            |                          |             |                 |            |            |         |  |  |  |  |  |  |
|--|----------------------------|--------------------------|-------------|-----------------|------------|------------|---------|--|--|--|--|--|--|
| Index No.                                    | Description                | Material or Model Number | Part Number | Required Number |            |            |         |  |  |  |  |  |  |
|  |                            |                          |             | K-0             | L-5 to P-5 | P-6 to P-8 | Q-5 Q-6 |  |  |  |  |  |  |
| 1  | Label – Penguin – HA(L)    | -                        | 4A0526-02   | 1               | 1          | 1          | 1       |  |  |  |  |  |  |
| 2  | Emblem – Hoshizaki         | -                        | 4A0560-01   | 1               | 1          | 1          | 1       |  |  |  |  |  |  |
| 3  | Label – Door Heater Switch | PVC Film                 | 4A1039-01   | 1               | 1          | 1          | 1       |  |  |  |  |  |  |
| 4  | Caution Label              | PVC Film                 | 4A1931-01   | 1               | 1          | 1          | 1       |  |  |  |  |  |  |
| 5  | Wiring Label               | PVC Film                 | 2A1952-01   | 1               | 1          | -          |         |  |  |  |  |  |  |
|  |                            |                          | 2A2342-01   |                 |            | 1          | 1       |  |  |  |  |  |  |
| 6  | Label – R-404A             | -                        | 4A0960-01   | 1               | 1          | 1          | 1       |  |  |  |  |  |  |
| 7  | Label – Power              | -                        | 4A2196-01   | 1               | 1          | 1          | 1       |  |  |  |  |  |  |
| 8  | Label – Display            | -                        | 4A2286-01   | 1               | 1          | 1          | 1       |  |  |  |  |  |  |
| 9  | Label – Warning            |                          | 4A2968-01   | 1               | 1          | 1          | 1       |  |  |  |  |  |  |
| 10   | Cover Nameplate            |                          | 4A3727-01   |                 |            |            | 1       |  |  |  |  |  |  |

## W. Literature & Packaging

### FH1-AAC(-HD), FH2-AAC(-HD)

K-0, L-0, L-5, M-5, M-6, M-7, M-8, N-5, N-6, P-5, P-6, P-7, P-8, Q-5, Q-6

| Title: <b>W. Literature &amp; Packaging</b> Model: <b>FH1-AAC(-HD), FH2-AAC(-HD)</b> |                      |  |             |                 |            |  |  |  |  |  |  |  |
|--|----------------------|--|-------------|-----------------|------------|--|--|--|--|--|--|--|
| Index No.  | Description          | Material or Model Number               | Part Number | Required Number |            |  |  |  |  |  |  |  |
|  |                      |  |             | K-0 to P-7      | P-8 to Q-6 |  |  |  |  |  |  |  |
| 1  | Instruction Manual   | Paper                                  | 91A34010L   | 1               | 1          |  |  |  |  |  |  |  |
| Packaging (Available only for models currently in production)                        |                      | <b>FH1-AAC</b>                         | 1A0765A17   | 1               | 1          |  |  |  |  |  |  |  |
|  |                      | <b>FH1-AAC-HD</b>                      | 1A0765A18   | 1               | 1          |  |  |  |  |  |  |  |
|  |                      | <b>FH2-AAC</b>                         | 1A0766A13   | 1               | 1          |  |  |  |  |  |  |  |
|  |                      | <b>FH2-AAC-HD</b>                      | 1A0766A14   | 1               | 1          |  |  |  |  |  |  |  |
| 1  | Filler – Door        |  | 4A2977-01   | 2               | 2          |  |  |  |  |  |  |  |
| 2  | Pad – Corner         |  | 3A2598-01   | 4               | 4          |  |  |  |  |  |  |  |
| 3  | Post – Corner        |  | 3A2603-01   | 4               | 4          |  |  |  |  |  |  |  |
| 4  | Support – Corner     |  | 3A2596-01   | 4               | 4          |  |  |  |  |  |  |  |
| 5  | Stop – Door          |  | 4A1873-01   | 1               | 1          |  |  |  |  |  |  |  |
| 6  | Stop – Door (Center) | <b>FH1-AAC-HD</b><br><b>FH2-AAC-HD</b> | 4A1874-01   | 1               | 1          |  |  |  |  |  |  |  |
| 7  | Flat Washer          |  | 7W2115800   | 4               | 4          |  |  |  |  |  |  |  |
| 8  | Hex Head Bolt        |  | 7B01 15825  | 4               | 4          |  |  |  |  |  |  |  |
| 9  | Pallet               | <b>FH1-AAC(-HD)</b>                    | 3A1814-01   | 1               | 1          |  |  |  |  |  |  |  |
|  |                      | <b>FH2-AAC(-HD)</b>                    | 3A1815-01   | 1               | 1          |  |  |  |  |  |  |  |
| 10   | Protector – Front    | <b>FH2-AAC(-HD)</b>                    | 3A2595-01   | 1               | 1          |  |  |  |  |  |  |  |
| 11   | Caster Shim          |  | HS-3590     |                 | 1          |  |  |  |  |  |  |  |
| 12   | Caster Kit           |  | HS-3546     |                 | 1          |  |  |  |  |  |  |  |
| 13   | Shelf Pack           |  | HS-3508     |                 | 1          |  |  |  |  |  |  |  |