



Reliability is a
beautiful thing™

HOSHIZAKI® **REACH-INS**

SafeTemp® Models

FH1-AAC(-HD)

FH2-AAC(-HD)

PARTS LIST

ITEM #: 71184
ISSUED: March 8, 1999
REVISED: June 27, 2005

CONTENTS

Material Abbreviations	4
Auxiliary Codes.....	5
Note About Ordering Parts	6
A. Reach-In.....	7
FH1-AAC(-HD)	7
FH2-AAC(-HD)	9
B. Refrigeration Assembly	11
FH1-AAC(-HD)	11
FH2-AAC(-HD)	13
C. Panel-Front Hinged Assembly.....	15
FH1-AAC(-HD), FH2-AAC(-HD)	15
D. Body-Final	16
FH1-AAC	16
FH1-AAC-HD.....	18
FH2-AAC	20
FH2-AAC-HD.....	22
E. Control Box Assembly	24
FH1-AAC(-HD), FH2-AAC(-HD)	24
F. Fan-Evaporator Assembly	27
FH1-AAC(-HD)	27
FH2-AAC(-HD)	29
G. Evaporator Assembly	30
FH1-AAC(-HD)	30
FH2-AAC(-HD)	32
H. Condenser Assembly	34
FH1-AAC(-HD)	34
FH2-AAC(-HD)	36
J. Body-Prefinal	37
FH1-AAC(-HD)	37
FH2-AAC(-HD)	39
K. Door-Right.....	41
FH1-AAC, FH2-AAC.....	41
L. Door-Left.....	42
FH2-AAC	42
M. Door-Half (UR).....	43
FH1-AAC-HD, FH2-AAC-HD	43
N. Door-Half (LR).....	44
FH1-AAC-HD, FH2-AAC-HD	44
P. Door-Half (UL).....	45
FH2-AAC-HD.....	45
Q. Door-Half (LL)	46
FH2-AAC-HD.....	46
R. Distributor-Air Top Assembly	47
FH1-AAC(-HD)	47

S. Mullion-Horizontal.....	48
FH1-AAC-HD.....	48
T. Mullion-Vertical.....	49
FH2-AAC.....	49
U. Mullion-Cross	51
FH2-AAC-HD.....	51
V. Label Location	53
FH1-AAC(-HD)	53
FH2-AAC(-HD)	54
W. Literature & Packaging	55
FH1-AAC(-HD), FH2-AAC(-HD)	55

Material Abbreviations

ALUMINUM

AL = Aluminum

COPPER

CU = Copper

PLASTIC

ABS = Acrylonitrile -butadiene - styrene
AC = Polyacetal
EVA = Ethylene vinyl acetate
PA = Polyamide = Nylon
PC = Polycarbonate
PE = Polyethylene
PES = Polyester
PETP = Polyethylene terephthalate = Tetlon
PP = Polypropylene
PS = Polystyrene
PTFE = Polytetrafluoroethylene = Teflon
PUR = Polyurethane
PVC = Polyvinyl chloride

RUBBER

VN = Vinyl Nitrile
EPDM = EP rubber
NBR = Nitrile butadiene rubber
NR = Natural rubber
NP = Neoprene
SI.R = Silicone rubber
SY.R = Synthetic rubber
EPH = Epichlorohydrin

STEEL

GS = Galvanized steel
SS = Stainless steel
PS = Plated steel
PAS = Primed steel

AUXILIARY CODE

K-5

 Designates the year. "K" indicates the year 2000. Years progress or regress in alphabetical order. "J" is 1999, "L" is 2001, "M" is 2002, and so on. The letters "I" and "O" were skipped.
 Designates significant part changes within the same year for this model. Base is 5 (0 for codes L-0 and earlier) and this number advances for each change.

Example: P-6

 "P" indicates 2004.
 "6" indicates the first significant part change for 2004.

Auxiliary Codes

FH1-AAC	K-0	October 2000
	L-5	March 2001
	M-5	January 2002
	M-6	February 2002
	M-7	July 2002
	N-5	December 2002
	N-6	January 2003
	P-5	December 2003
	P-6	March 2004
	P-7	October 2004
	P-8	November 2004
	Q-5	December 2004
	Q-6	June 2005
FH1-AAC-HD	K-0	October 2000
	L-0	November 2000
	L-5	March 2001
	M-5	January 2002
	M-6	March 2002
	M-7	July 2002
	N-6	January 2003
	P-5	February 2004
	P-6	March 2004
	Q-5	December 2004
	Q-6	June 2005
FH2-AAC	L-5	February 2001
	M-5	January 2002
	M-6	March 2002
	M-7	July 2002
	M-8	August 2002
	N-5	December 2002
	N-6	January 2003
	P-5	December 2003
	P-6	August 2004
	P-7	November 2004
	Q-5	December 2004
	Q-6	June 2005

Auxiliary Codes

FH2-AAC-HD

K-0	August 2000
L-5	July 2001
M-6	March 2002
N-6	February 2003
P-5	January 2004
P-6	August 2004
P-7	October 2004
P-8	November 2004
Q-5	December 2004
Q-6	June 2005

Note About Ordering Parts

Most assemblies cannot be ordered as complete units; parts in the assemblies generally must be ordered separately.

A. Reach-In
FH1-AAC(-HD)

K-0, L-0, L-5, M-5, M-6, M-7, N-5, N-6, P-5, P-6, P-7, P-8, Q-5, Q-6

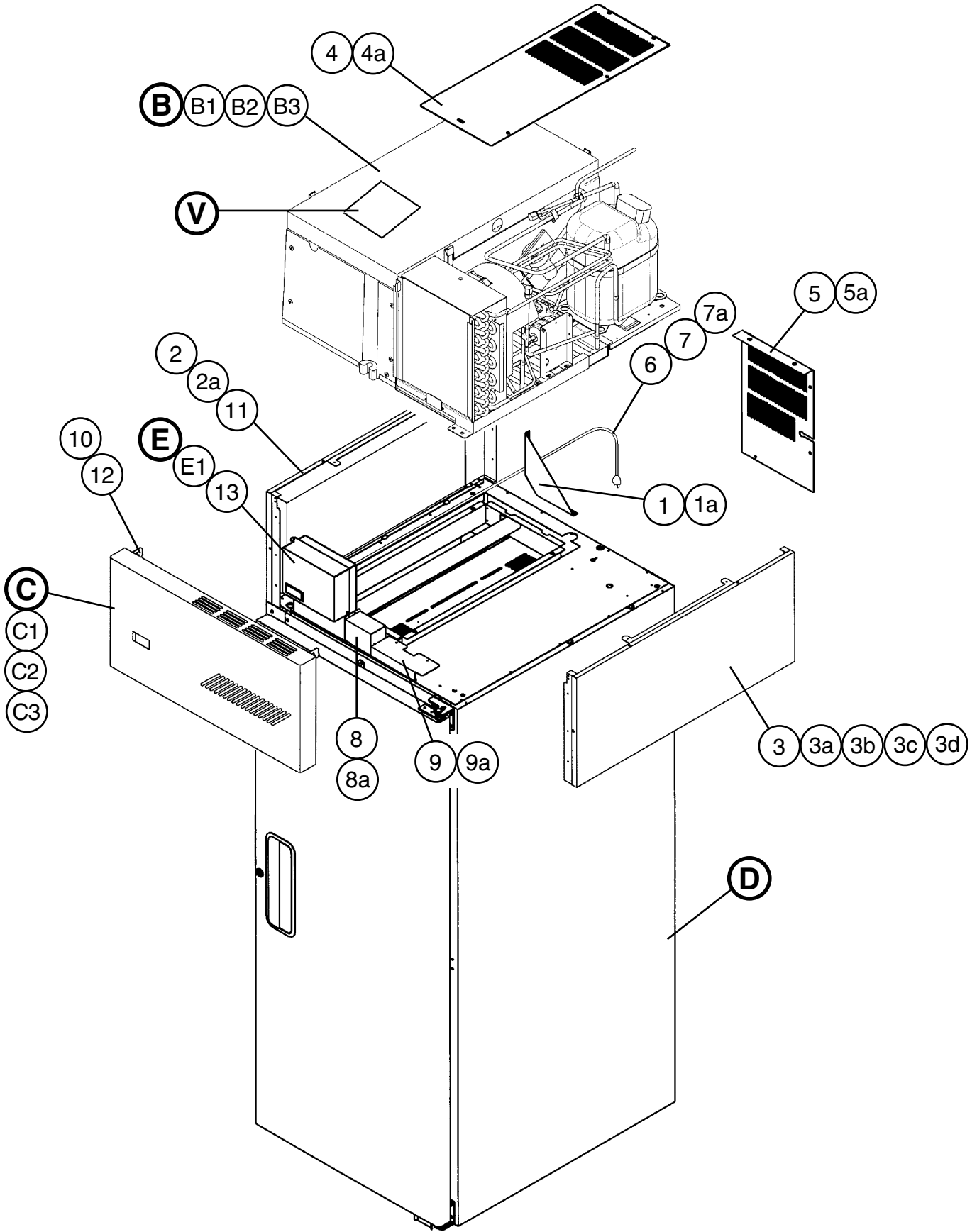

Title: A. Reach-In Model: FH1-AAC(-HD)										
Index No.	Description	Material or Model Number	Part Number	Required Number						
				K-0 to L-5	M-5 to N-5	N-6 to Q-6				
B	Refrigeration System	Refrigerator	1A0524A01	1	1	1				
B1	Bolt Assembly	8x45	437889-01	5	5	5				
B2	Truss Head Screw	5x25, SS	7C32-0525	2	2	2				
B3	Washer	5	7W22-0500	2	2	2				
C	Panel – Front Hinged Assembly	-	3A1670A01	1	1	1				
C1	Clevis Pin	-	8907-0102	2	2	2				
C2	Cotter Pin	-	8907-0103	2	2	2				
C3	Flat Washer	-	4A0655-03	2	2	2				
D	Body – Final	FH1-AAC	1A0299A05	1	1	1				
		FH1-AAC-HD	1A0360A03	1	1	1				
E	Control Box Assembly	-	2A1842A03	1	1	1				
E1	T2 Screw	4x8, SS	7P32-0408	3	3	3				
V	Label Location	FH1-AAC	2A1042A09	1	1	1				
		FH1-AAC-HD	2A1042A08	1	1	1				
1	Gusset – Frame	GS	3A1520-01	1	1	-				
			4A2845-01			1				
1a	T2 Screw	4x8, SS	7P32-0408	4	4	4				
2	Frame – Side Top	GS	2A1803-01	2	2	2				
2a	Truss Head Screw	5x10, SS	7C32-0510	8	8	8				
3	Panel – Side, Top	AL	2A1800-21	2	2	2				
3a	Truss Head Screw	5x10, SS	7C32-0510	6	6	6				
3b	Taper Collar	SS	4H0171-01	2	2	2				
3c	Screw Countersunk	5x20, SS	7C42-0520	2	2	2				
3d	T2 Screw	4x8, SS	7P32-0408	4	4	4				
4	Cover UL Top	GS	2A1304-01	1	-					
			2A2373-01		1	-				
			2A2755-01			1				
4a	T2 Screw	4x8, SS	7P32-0408	5	5	5				
5	Cover – UL, Rear	GS	2A0956-01	1	1	-				
			2A2752-01			1				
5a	T2 Screw	4x8, SS	7P32-0408	4	4	4				
6	Power Cord	-	4A0520-01	1	1	1				
7	Wire Clamp	-	4A0809-02	1	1	1				
7a	T2 Screw	4x8, SS	7P32-0408	1	1	1				
8	Cover – Connector Wire	GS	3A1678-01	1	1	1				
8a	T2 Screw	4x8, SS	7P32-0408	2	2	2				
9	Cover – Wire	GS	3A1679-01	1	1	1				
9a	T2 Screw	4x8, SS	7P32-0408	3	3	3				
10	Bracket – Hinge	GS	4A2306-01	2	2	2				
11	Threaded Insert	M5	4A0407-01	4	4	4				
12	Spacer – Hinge	PA	4A2473-01	2	2	2				
13	Bracket – Control Box	GS	4A2467-01	1	1	1				

**A. Reach-In
FH2-AAC(-HD)**

K-0, L-5, M-5, M-6, M-7, M-8, N-5, N-6, P-5, P-6, P-7, P-8, Q-5, Q-6

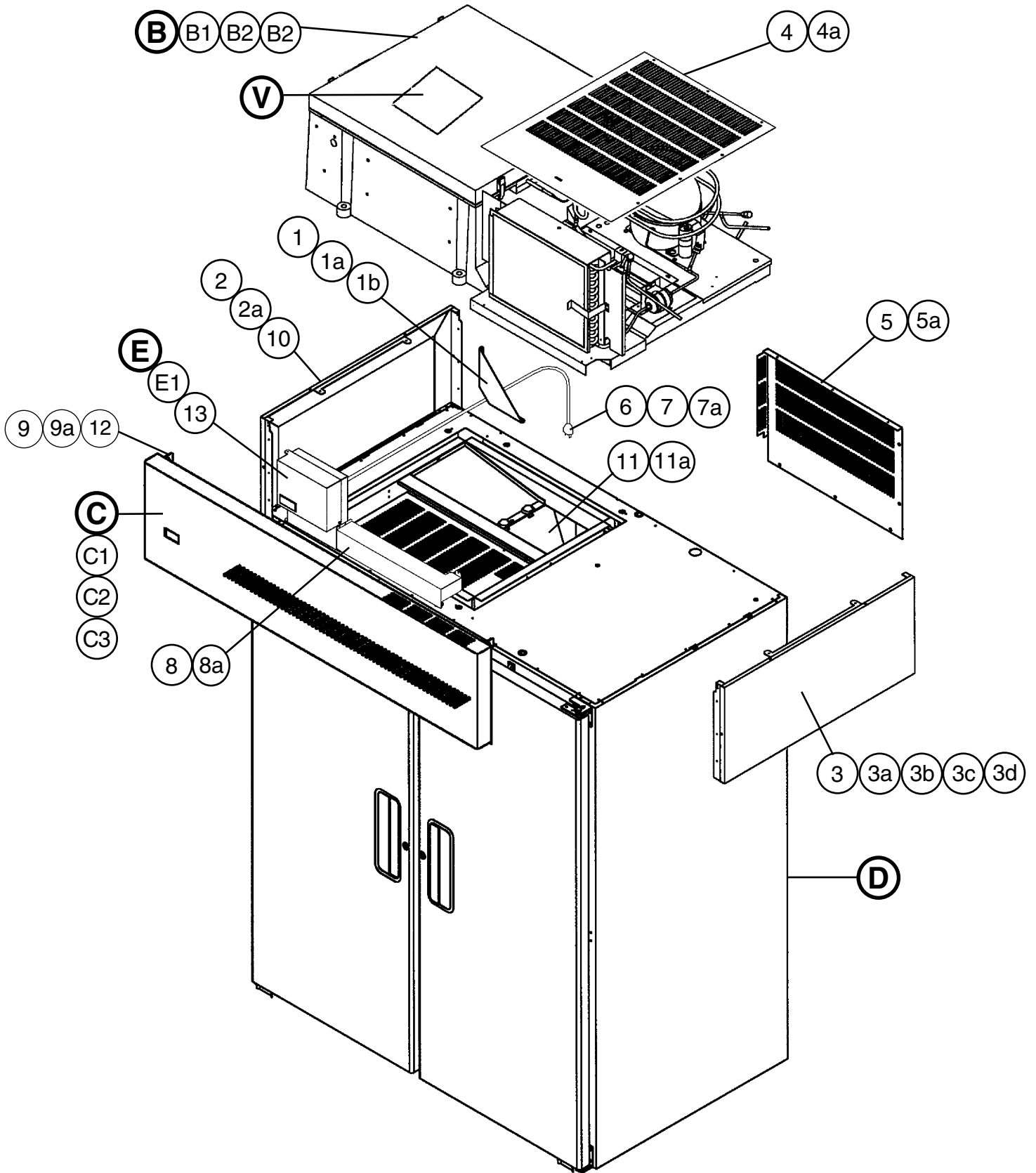

Title: A. Reach-In Model: FH2-AAC(-HD)											
Index No.	Description	Material or Model Number	Part Number	Required Number							
				K-0 to N-5	N-6 to Q-6						
B	Refrigeration System	-	1A0255A02	1	1						
B1	Bolt Assembly	8x45	437889-01	6	6						
B2	Hex Bolt	8x70	7B01-0870	2	2						
B3	Washer	8	7W22-0800	2	2						
C	Panel – Front Hinged Assembly	-	3A1670A02	1	1						
C1	Clevis Pin	-	8907-0102	2	2						
C2	Cotter Pin	-	8907-0103	2	2						
C3	Flat Washer	-	4A0655-03	2	2						
D	Body – Final	FH2-AAC	2A1215A05	1	1						
		FH2-AAC-HD	1A0370A03	1	1						
E	Control Box Assembly	-	2A1842A05	1	1						
E1	T2 Screw	4x8, SS	7P32-0408	4	4						
V	Label Location	FH2-AAC	3A0603G09	1	1						
		FH2-AAC-HD	3A0603G08	1	1						
1	Gusset – Frame	GS	3A1520-01	1	-						
		GS	4A2845-01		1						
1a	T2 Screw	4x8, SS	7P32-0408	2	2						
1b	Truss Head Screw	5x10, SS	7C32-0510	2	2						
2	Frame – Side Top	GS	2A1803-01	2	2						
2a	Truss Head Screw	5x10	7C32-0510	8	8						
3	Panel – Side, Top	AL	2A1800-21	2	2						
3a	Truss Head Screw	5x10, SS	7C32-0510	6	6						
3b	Taper Collar	SS	4H0171-01	2	2						
3c	Countersunk Screw	5x20, SS	7C42-0520	2	2						
3d	T2 Screw	4x8, SS	7P32-0408	4	4						
4	Top UL Cover	GS	2A1118-03	1	1						
4a	T2 Screw	4x8, SS	7P32-0408	5	5						
5	Rear UL Cover	GS	2A1117-01	1	1						
5a	T2 Screw	4x8, SS	7P32-0408	5	5						
6	Power Cord Set	-	4A1543-01	1	1						
7	Wire Clamp	-	4A0809-03	1	1						
7a	Truss Head Screw	5x8, SS	7C32-0508	1	1						
8	Cover – Wire	GS	2A1861-01	1	1						
8a	T2 Screw	4x8	7P32-0408	3	3						
9	Bracket – Hinge	-	4A2306-01	2	2						
9a	Truss Head Screw	4x8	7C32-0408	2	2						
10	Threaded Insert	M5	4A0407-01	4	4						
11	Distributor – Air Top	-	1A0152-05	1	1						
11a	T2 Screw	4x8, SS	7P32-0408	7	7						
12	Spacer – Hinge	PA	4A2473-01	2	2						
13	Bracket – Control Box	GS	4A2467-01	1	1						

B. Refrigeration Assembly FH1-AAC(-HD)

K-0, L-0, L-5, M-5, M-6, M-7, N-5, N-6, P-5, P-6, P-7, P-8, Q-5, Q-6

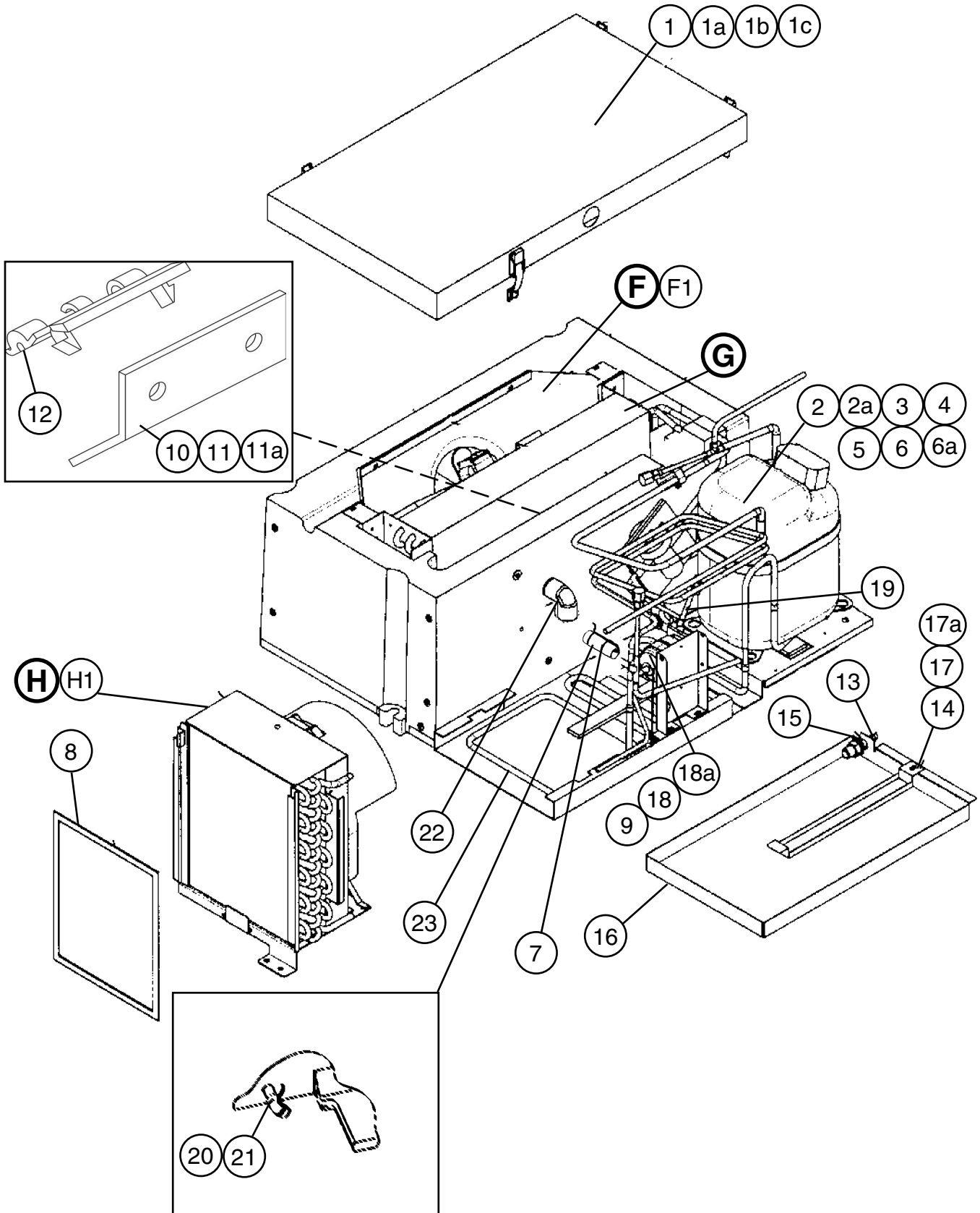

Title: **B. Refrigeration Assembly** Model: **FH1-AAC(-HD)**

Index No.	Description	Material or Model Number	Part Number	Required Number																	
				K-0 to M-5	M-6 to N-5	N-6	P-5 P-6	P-7 to Q-6													
F	Fan – Evap Assembly		HS-3545	Non-interchangable part change at M-6. See Assembly F.	-																
			2A2517A01		1	1	-														
			2A2517A02				1	1													
F1	Truss Head Screw	4x12, SS	7C32-0412	4	4	4	4	4													
G	Evaporator Assembly	-	2A0981A03	1	1	1	1	1													
H	Condenser Assembly	-	3A0724A02	1	1	-															
			3A2610A02			1	1	1													
H1	T2 Screw	4x8, SS	7P32-0408	2	2	2	2	2													
1	Cover – Evap Case (1 Sec)	-	2A0428G01	1	1	-															
			2A2726G01			1	1	1													
1a	Draw Latch	97-50-224-11	4A1710-01	4	4	4	4	4													
1b	Truss Head Screw	4x16, SS	7C32-0416	4	4	4	4	4													
1c	T2 Screw	4x8, SS	7P32-0408	8	8	8	8	8													
2	Compressor	-	2A0937-01	1	1	1	1	1													
2a	Protector	-	4A1860-02	1	1	1	1	1													
3	Sleeve	-	4A0449-01	4	4	4	4	4													
4	Grommet – Comp. Mount	-	4A1305-01	4	4	4	4	4													
5	Flat Washer	-	7W21-0800	4	4	4	4	4													
6	Hex Bolt	-	7B01-0845	4	4	4	4	4													
6a	Split Lock Washer	-	7L21-0800	4	4	4	4	4													
7	Pipe – Evap Drain	PVC	4A0831-01	1	1	1	1	1													
8	Filter – Cond	-	3A0277-01	1	1	1	1	1													
9	Drier	SPORLAN CW-052-S	4A0924-01	1	1	1	1	1													
10	Thermistor – Cabinet	Thermistor is to be replaced using kit HS-3540. Apply to all aux. codes.		-	-	-	-	-													
11	Thermistor Bracket (A)	ABS	433964-01	1	1	1	1	1													
11a	Truss Head Screw	4x16, SS	7C32-0416	2	2	2	2	2													
12	Thermistor Bracket (B)	ABS	433920-01	1	1	1	1	1													
13	Fitting – Drain Overflow		4A2182-01	1	1	1	1	1													
14	Gasket – Cond. Coil	-	4A0455-03	1	1	1	1	1													
15	Rubber Gasket	-	413854-03	1	1	1	1	1													
16	Pan – Evap. Drain	-	2A0616-02	1	1	-															
			2A2760-01			1	1	1													
17	Strap – Condensate Coil	-	3A0232-03	1	1	1	1	1													
17a	Truss Head Screw	5x12, SS	7C32-0512	2	2	2	2	2													
18	Drier Bracket	-	4A0806-01	1	1	1	1	1													
18a	T2 Screw	4x8, SS	7P32-0408	2	2	2	2	2													
19	Switch – Pressure	-	4A2516-02	1	1	1	1	1													
20	Heater – Drain	10758 10w115v	4A2975-01					1													
21	Nylon Ties	CV-200	8911-0200					1													
22	Pressure – Check Valve		HS-3515	1	-																
23	Coil – Condensate		3A1644-01	1	1	1	1	1													

B. Refrigeration Assembly FH2-AAC(-HD)

K-0, L-5, M-5, M-6, M-7, M-8, N-5, N-6, P-5, P-6, P-7, P-8, Q-5, Q-6

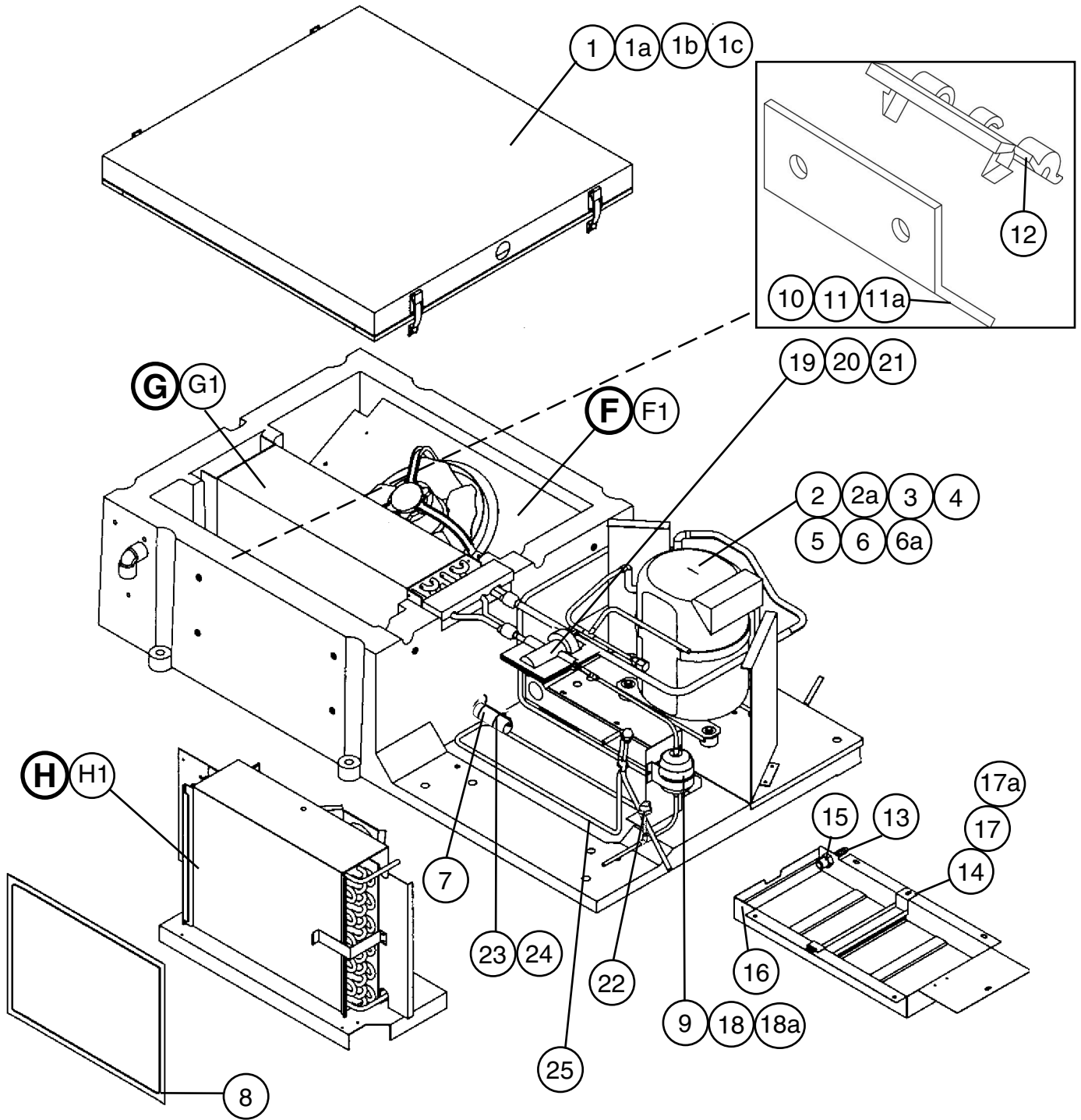

Title: B. Refrigeration Assembly Model: FH2-AAC(-HD)											
Index No.	Description	Material or Model Number	Part Number	Required Number							
				K-0 to P-5	P-6 to Q-6						
F	Evap Shroud Assm	-	3A0263G01	1	-						
			3A0263G02		1						
F1	Truss Head Screw	4x16, SS	7C32-0416	2	2						
G	Evaporator Assembly	-	2A1015A02	1	1						
G1	T2 Screw	4x8, SS	7P32-0408	2	2						
H	Condenser Assembly	-	3A0585A01	1	1						
H1	T2 Screw	4x8, SS	7P32-0408	4	4						
1	Cover – Evap Case	-	2A0245G01	1	1						
1a	Draw Latch	97-50-224-11	4A1710-01	4	4						
1b	Truss Head Screw	4x16, SS	7C32-0416	4	4						
1c	T2 Screw	4x8, SS	7P32-0408	8	8						
2	Compressor	-	4A1346-01	1	1						
2a	Protector	-	4A1877-05	1	1						
3	Spacer	-	434404-01	4	4						
4	Grommet – Comp. Mount	-	434403-01	4	4						
5	Flat Washer	-	7W21-0800	4	4						
6	Hex Bolt	-	7B01-0845	4	4						
6a	Split Lock Washer	-	7L21-0800	4	4						
7	Pipe – Evap Drain	PVC	3A0143-01	1	1						
8	Filter – Condenser	-	3A0277-02	1	1						
9	Drier	SPORLAN CW-052-S	4A0924-01	1	1						
10	Thermistor – Cabinet	Thermistor is to be replaced using kit HS-3540. Apply to all aux. codes.		-	-						
11	Thermistor Bracket (A)	ABS	433964-01	1	1						
11a	Truss Head Screw	4x16, SS	7C32-0416	2	2						
12	Thermistor Bracket (B)	ABS	433920-01	1	1						
13	Fitting – Drain Overflow	-	4A2182-01	1	1						
14	Gasket – Cond. Coil	-	4A0455-01	1	1						
15	Rubber Gasket	-	413854-03	1	1						
16	Pan – Evaporator Drain	-	2A0200-02	1	1						
17	Strap – Condensate Coil	-	3A0413-03	1	1						
17a	Truss Head Screw	5x10, SS	7C32-0510	1	1						
18	Drier Bracket	-	4A0806-01	1	1						
18a	T2 Screw	4x8, SS	7P32-0408	2	2						
19	Expansion Valve Cover (A)	-	3A0372-01	1	1						
20	Expansion Valve Cover (B)	-	3A0372-02	1	1						
21	Valve – Expansion	-	4A0922-01	1	1						
22	Switch – Pressure	-	4A2516-02	1	1						
23	Heater – Drain	10758 10w115v	4A2975-01		1						
24	Nylon Ties	CV-200	8911-0200		1						
25	Coil – Condensate		2A1856-01	1	1						

C. Panel-Front Hinged Assembly FH1-AAC(-HD), FH2-AAC(-HD)

K-0, L-0, L-5, M-5, M-6, M-7, M-8, N-5, N-6, P-5, P-6, P-7, P-8, Q-5, Q-6

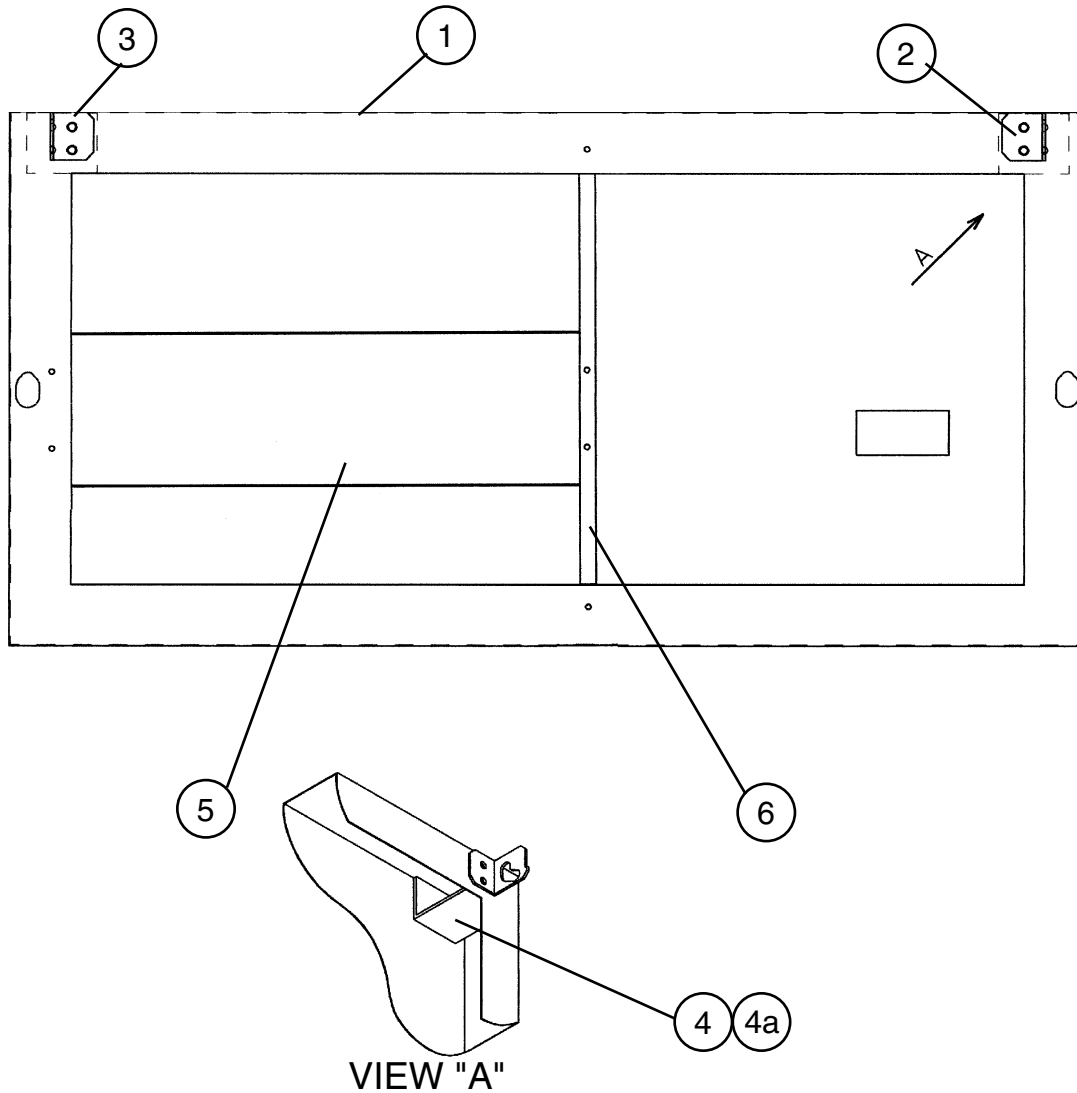

Title: C. Panel-Front Hinged Assembly Model: FH1-AAC(-HD), FH2-AAC(-HD)					Required Number								
Index No.	Description	Material or Model Number	Part Number	K-0 to Q-6									
1	Panel – Front Hinged	FH1-AAC(-HD)	2A1799-01	1									
		FH2-AAC(-HD)	2A1799-02	1									
2	Hinge – Front Panel (L)	GS	4A2153-01	1									
3	Hinge – Front Panel (R)	GS	4A2154-01	1									
4	Channel – Hinge	GS	4A2170-01	2									
4a	Truss Head Screw	5x8, SS	7C32-0508	4									
5	Blind	FH1-AAC(-HD)	3A1763-01	1									
		FH2-ACC(-HD)	3A1763-02	1									
6	Support – Blind	-	4A2267-01	1									

D. Body-Final
FH1-AAC

K-0, L-5, M-5, M-6, M-7, N-5, N-6, P-5, P-6, P-7, P-8, Q-5, Q-6

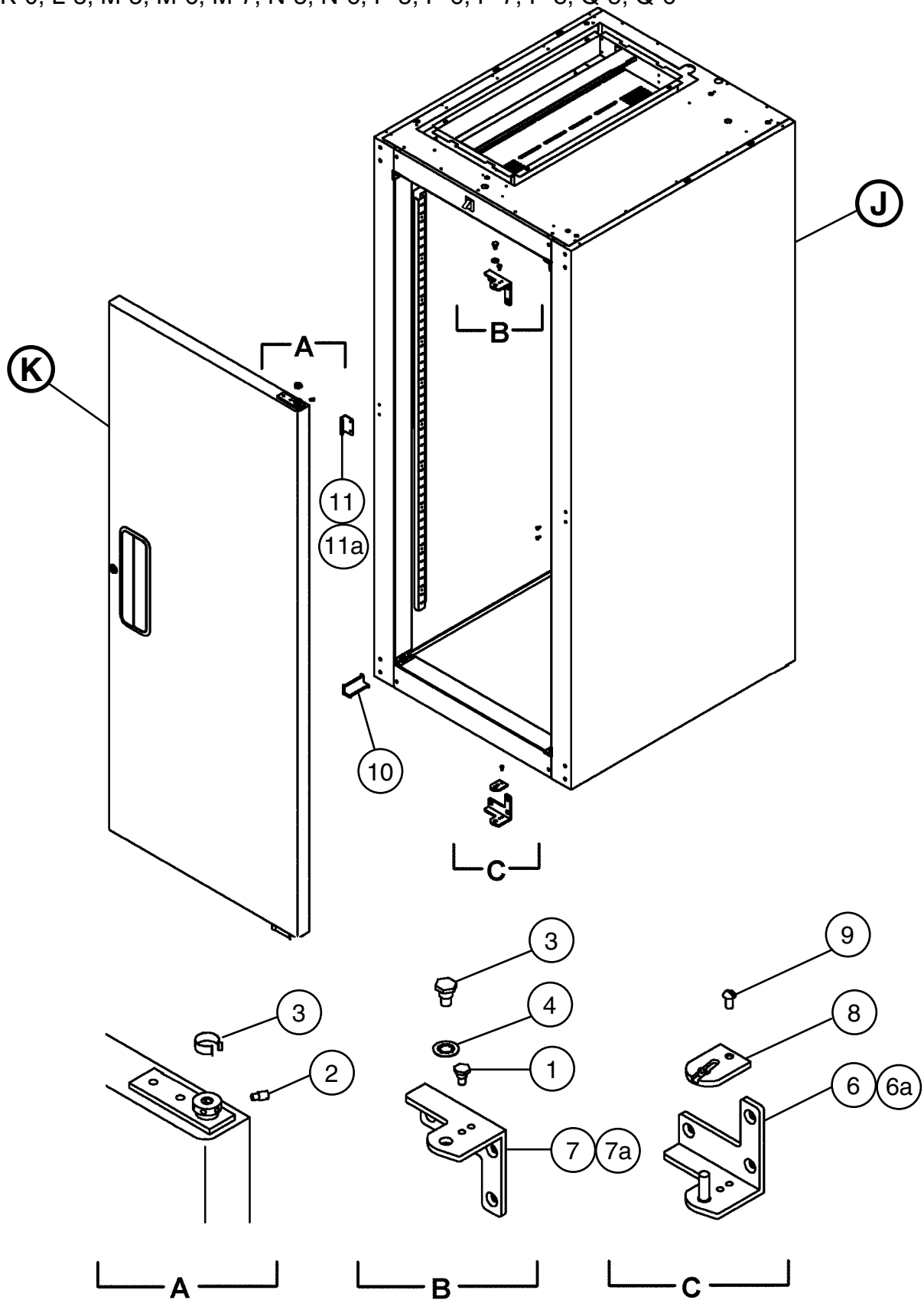

Title: D. Body Final Model: FH1-AAC												
Index No.	Description	Material or Model Number	Part Number	Required Number								
				K-0 to Q-6								
J	Body – Prefinal	-	1A0298A04	1								
K	Door – Right	-	1A0318A03	1								
1	Hinge – Stop Pin	PS	4A2180-01	1								
2	Hinge – Tension Screw	PS	4A0446-01	1								
3	Hinge – Bushing Cover	SS	4A0445-01	1								
4	Hinge – Lock Washer	PS	4A0553-01	1								
5	Hinge – Pivot Pin (Top)	PS	4A2179-01	1								
6	Bracket – Door Hinge (LR)	PS	3A1626-01	1								
6a	Countersunk Screw	5x10, SS	7C42-0510	3								
7	Bracket – Door Hinge (UR)	PS	3A1580-01	1								
7a	Countersunk Screw	5x10, SS	7C42-0510	3								
8	Hingestop Plate (R)	PS	4A0441-01	1								
9	Screw – Stop Plate	PS	4A0483-01	1								
10	Cover – Corner	ABS	3A1751-01	4								
11	Plate – Strike (Side)	SS	4A0470-01	1								
11a	T2 Screw	4x8, SS	7P32-0408	2								

D. Body-Final FH1-AAC-HD

K-0, L-0, L-5, M-5, M-6, M-7, N-6, P-5, P-6, Q-5, Q-6

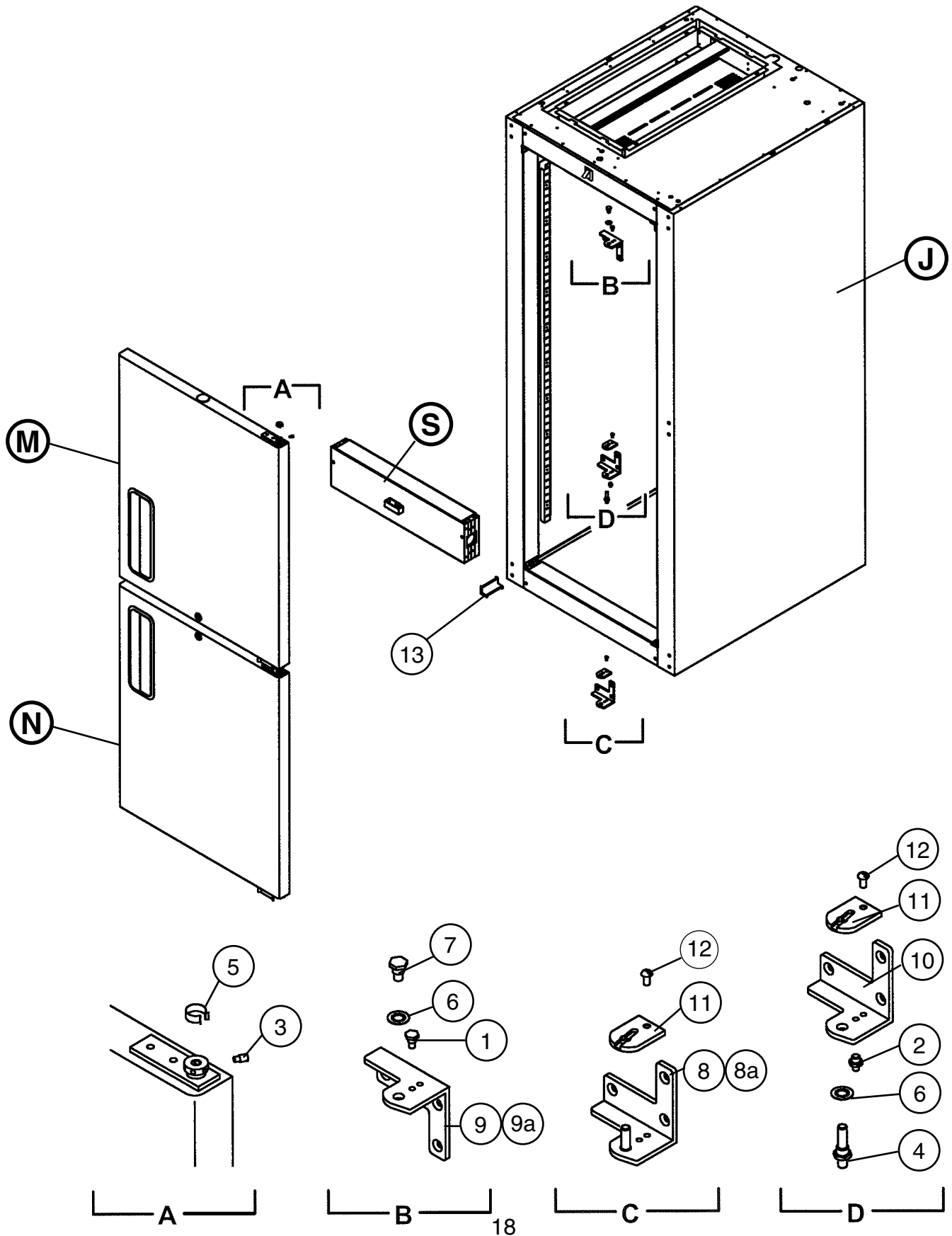

Title: D. Body-Final Model: FH1-AAC-HD												
Index No.	Description	Material or Model Number	Part Number	Required Number								
				K-0 to Q-6								
J	Body – Prefinal	-	1A0354A03	1								
M	Door – Half (UR)	-	1A0326A03	1								
N	Door – Half (LR)	-	1A0324A03	1								
S	Mullion – Horizontal	-	2A1323A03	1								
1	Hinge – Stop Pin	PS	4A2180-01	1								
2	Stop Pin	PS	4A1734-01	1								
3	Hinge – Tension Screw	SS	4A0446-01	2								
4	Pivot Pin	PS	4A1735-01	1								
5	Hinge – Bushing Cover	PS	4A0445-01	2								
6	Hinge – Lock Washer	PS	4A0553-01	2								
7	Hinge – Pivot Pin (Top)	PS	4A2179-01	1								
8	Bracket – Door Hinge (LR)	PS	3A1626-01	1								
8a	Countersunk Screw	5x10, SS	7C42-0510	3								
9	Bracket – Door Hinge (UR)	PS	3A1580-01	1								
9a	Countersunk Screw	5x10, SS	7C42-0510	3								
10	Bracket – Door Hinge (UL)	PS	3A1581-01	1								
10a	Truss Head Screw	5x10, SS	7C32-0510	3								
11	Hinge – Stop Plate (R)	PS	4A0441-01	2								
12	Screw – Stop Plate	PS	4A0483-01	2								
13	Cover – Corner	ABS	3A1751-01	8								

D. Body-Final
FH2-AAC

L-5, M-5, M-6, M-7, M-8, N-5, N-6, P-5, P-6, P-7, Q-5, Q-6

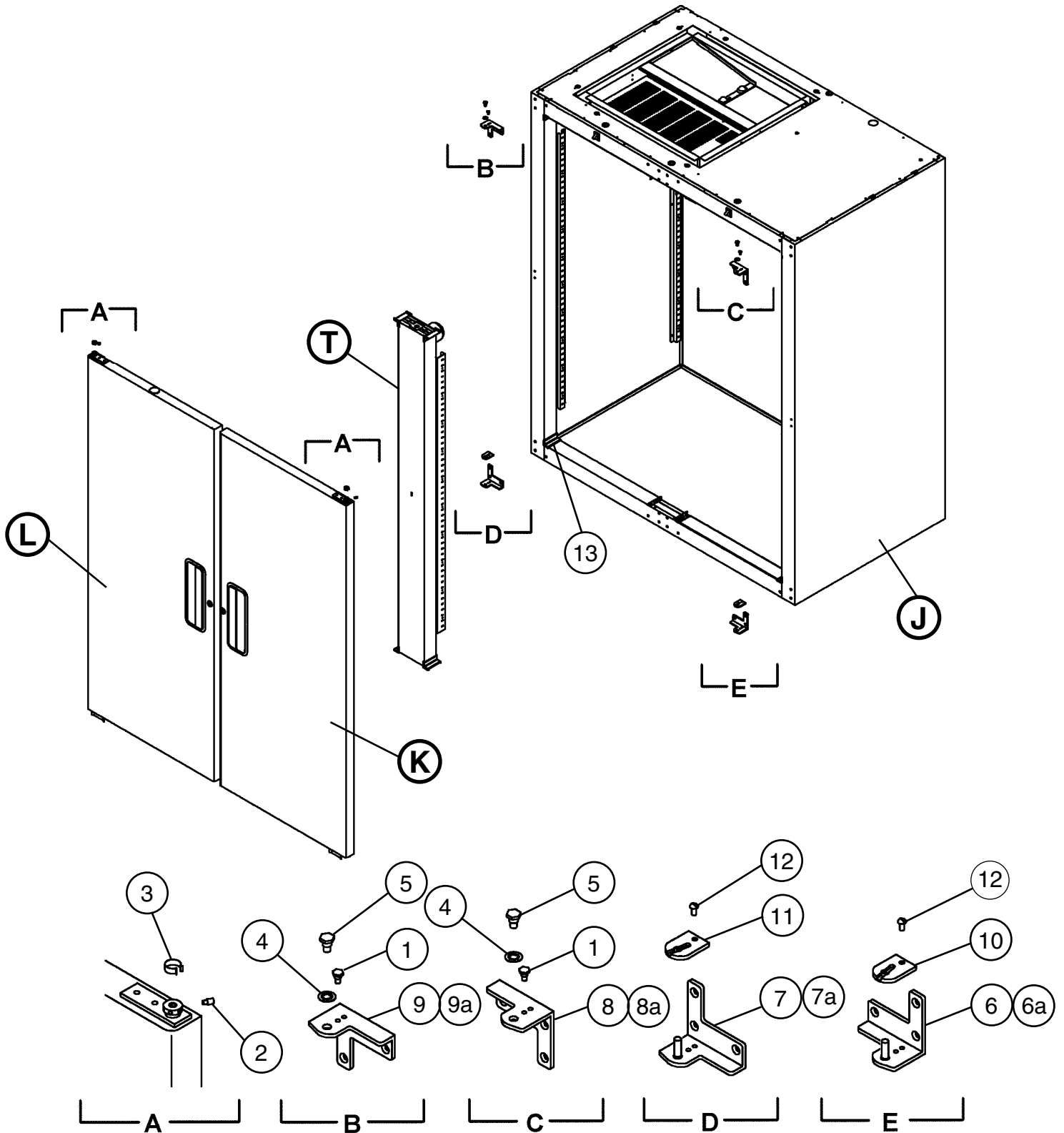

Title: D. Body Final Model: FH2-AAC													
Index No.	Description	Material or Model Number	Part Number	Required Number									
				L-5 to Q-6									
J	Body – Prefinal	-	2A1207A05	1									
K	Door – Right	-	1A0318A03	1									
L	Door – Left	-	1A0318A04	1									
T	Mullion – Vertical	-	2A1289A04	1									
1	Hinge – Stop Pin	PS	4A2180-01	2									
2	Hinge – Tension Screw	PS	4A0446-01	2									
3	Hinge – Bushing Cover	SS	4A0445-01	2									
4	Hinge – Lock Washer	PS	4A0553-01	2									
5	Hinge – Pivot Pin (Top)	PS	4A2179-01	2									
6	Bracket – Door Hinge (LR)	PS	3A1626-01	1									
6a	Countersunk Screw	5x10, SS	7C42-0510	3									
7	Bracket – Door Hinge (LL)	PS	3A1627-01	1									
7a	Countersunk Screw	5x10, SS	7C42-0510	3									
8	Bracket – Door Hinge (UR)	PS	3A1580-01	1									
8a	Countersunk Screw	5x10, SS	7C42-0510	3									
9	Bracket – Door Hinge (UL)	PS	3A1581-01	1									
9a	Countersunk Screw	5x10, SS	7C42-0510	3									
10	Hinge – Stop Plate (R)	PS	4A0441-01	1									
11	Hinge – Stop Plate (L)	PS	4A0441-02	1									
12	Screw – Stop Plate	PS	4A0483-01	2									
13	Cover – Corner	ABS	3A1751-01	8									

D. Body-Final FH2-AAC-HD

K-0, L-5, M-6, N-6, P-5, P-6, P-7, P-8, Q-5, Q-6

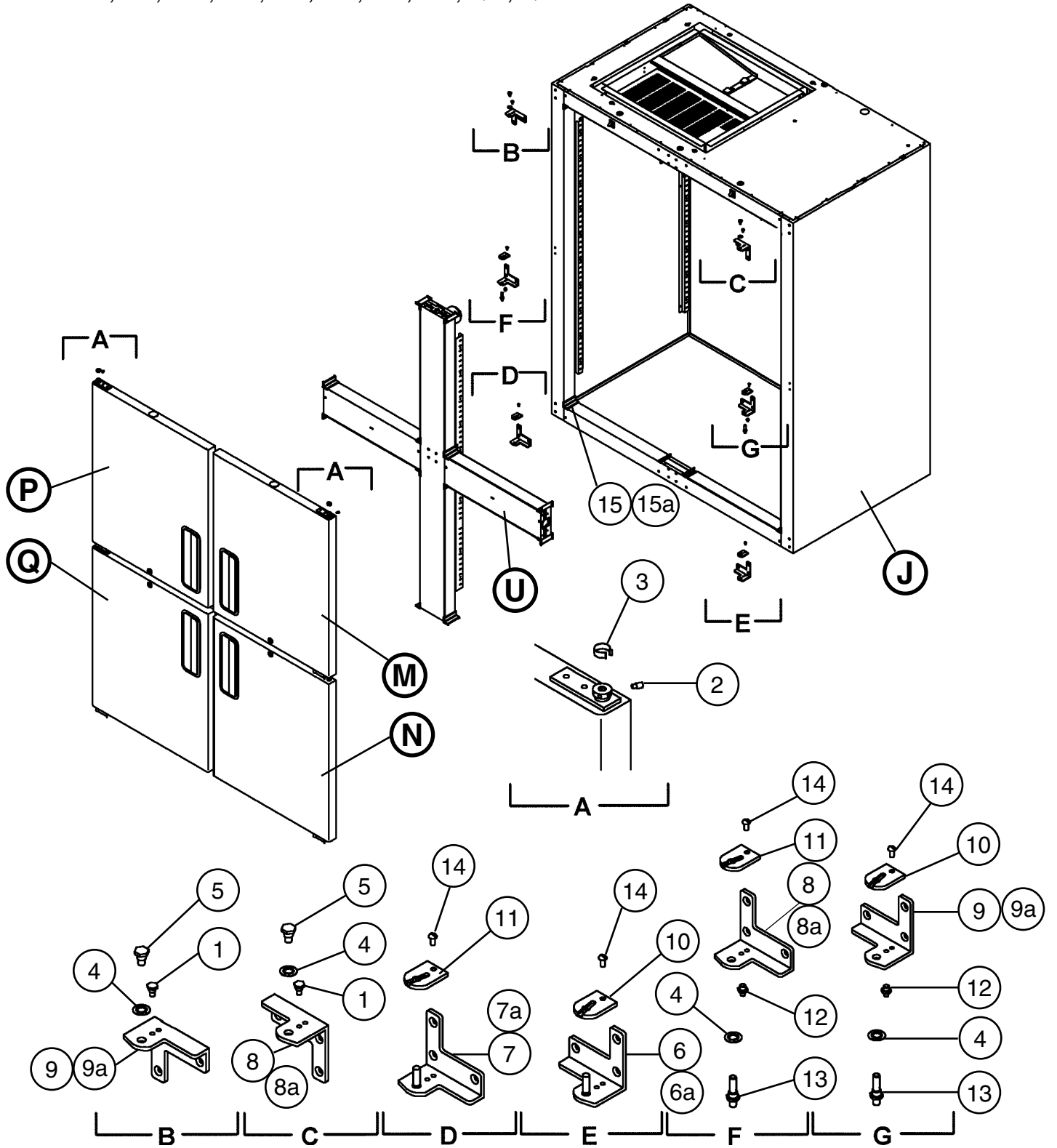

Title: **D. Body Final** Model: **FH2-AAC-HD**

Index No.	Description	Material or Model Number	Part Number	Required Number																
				K-0 to Q-6																
J	Body – Prefinal	-	2A1347A03	1																
M	Door – Half (UR)	-	1A0326A03	1																
N	Door – Half (LR)	-	1A0324A03	1																
P	Door – Half (UL)	-	1A0324A04	1																
Q	Door – Half (LL)	-	1A0326A04	1																
U	Mullion – Cross	-	2A1350A03	1																
1	Hinge – Stop Pin	PS	4A2180-01	2																
2	Hinge – Tension Screw	PS	4A0446-01	4																
3	Hinge – Bushing Cover	SS	4A0445-01	4																
4	Hinge – Lock Washer	PS	4A0553-01	4																
5	Hinge – Pivot Pin (Top)	PS	4A2179-01	2																
6	Bracket – Door Hinge (LR)	PS	3A1626-01	1																
6a	Countersunk Screw	5x10, SS	7C42-0510	3																
7	Bracket – Door Hinge (LL)	PS	3A1627-01	1																
7a	Countersunk Screw	5x10, SS	7C42-0510	3																
8	Bracket – Door Hinge (UR)	PS	3A1580-01	2																
8a	Countersunk Screw	5x10, SS	7C42-0510	6																
9	Bracket – Door Hinge (UL)	PS	3A1581-01	2																
9a	Countersunk Screw	5x10, SS	7C42-0510	6																
10	Hinge – Stop Plate (R)	PS	4A0441-01	2																
11	Hinge – Stop Plate (L)	PS	4A0441-02	2																
12	Stop Pin	PS	4A1734-01	2																
13	Pivot Pin	PS	4A1735-01	2																
14	Screw – Stop Plate	PS	4A0483-01	4																
15	Cover – Corner	ABS	3A1751-01	16																
15a	Truss Head Screw	5x10, SS	7C32-0510	26																

E. Control Box Assembly

FH1-AAC(-HD), FH2-AAC(-HD)

K-0, L-0, L-5, M-5, M-6, M-7, M-8, N-5, N-6, P-5, P-6, P-7, P-8, Q-5, Q-6

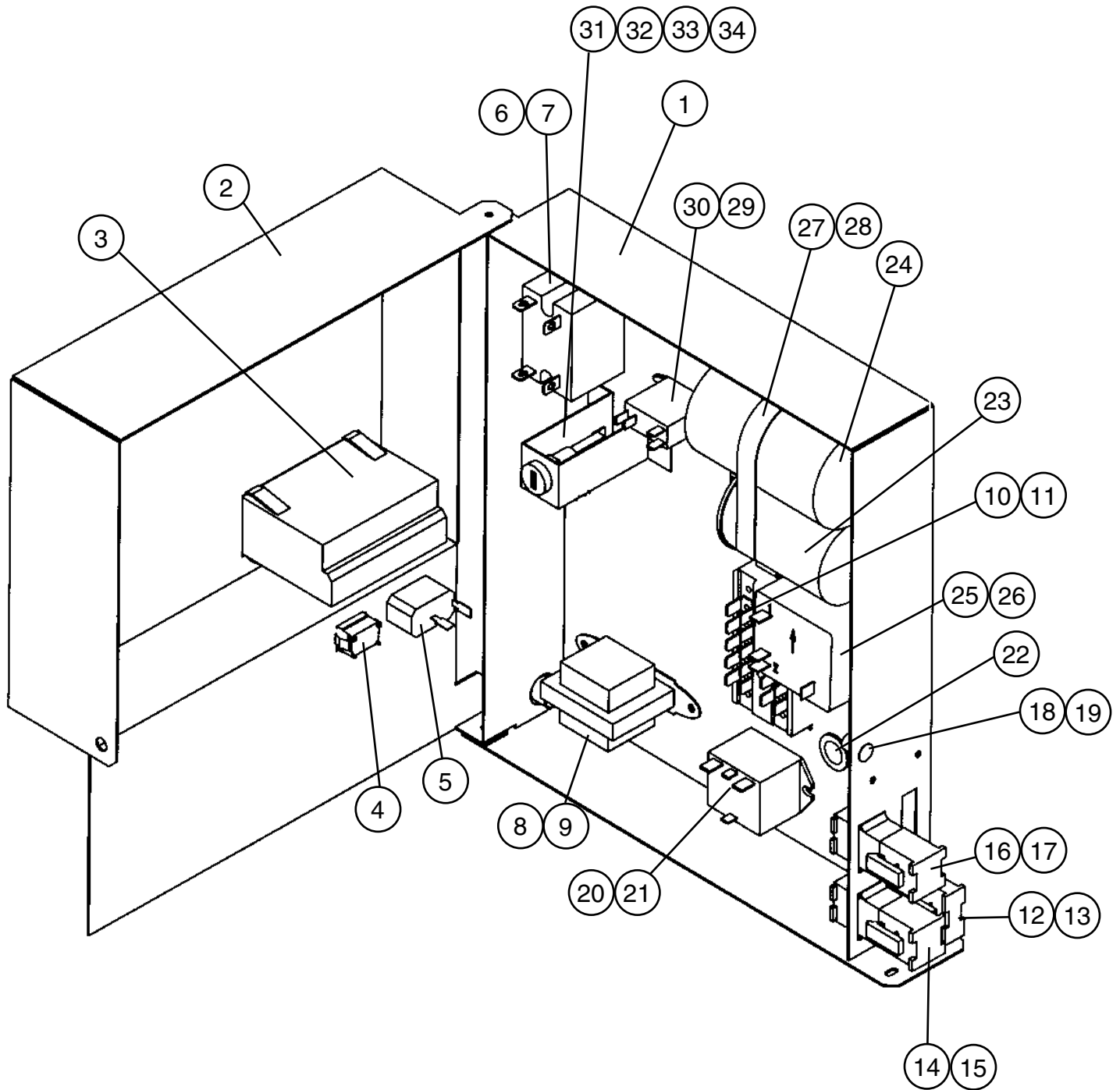

Title: **E. Control Box Assembly** Model: **FH1-AAC(-HD), FH2-AAC(-HD)**

Index No.	Description	Material or Model Number	Part Number	Required Number									
				K-0 to M-5	M-6 to M-8	N-5	P-5	P-6 P-7	Q-5	Q-6			
1	Base – Control Box	GS	2A1887-01	1	1	1	1	1	1	1			
2	Cover – Control Box	GS	2A1833-01	1	1	1	1	1	1	1			
3	Board – Control Display	Use latest for all aux. codes	4A2203-02	1	1	1	1	-					
			4A2203-05					1	-				
	Controller		3A3372-05						1	-			
	3A3656-06									1			
4	Switch – Rocker	1801.110	4A0418-01	1	1	1	1	1	1	1			
5	Switch – Toggle	780K21	4A0424-01	1	1	1	1	1	1	1			
6	Relay – Compressor	HE1aN-AC120V	4A1307-01	1	1	1	1	1	1	1			
7	Tapping Screw	3x8	431415-01	1	1	1	1	1	1	1			
8	Transformer	BE110805GAA	4A2202-01	1	1	1	1	1	1	1			
9	Tapping Screw	3x8	431415-01	2	2	2	2	2	2	2			
10	Terminal Block	FH1-AAC(-HD) FH2-AAC(-HD)	4A1540-01	1	-								
			4A2619-01		1	1	1	1	1	1	1		
11	Tapping Screw	3x8	431415-01	1	2	2	2	2	2	2			
12	Plug Housing	3/12/35	4A0425-01	1	1	1	1	1	1	1			
13	Receptacle Housing	03-12-1036	4A0426-01	1	1	1	1	1	1	1			
14	Plug Housing (6 Pin)	3191-06P	412832-03	1	1	1	1	1	1	1			
15	Receptacle Housing (6 Pin)	3191-06R1	412831-03	1	1	1	1	1	1	1			
16	Plug Housing (6 Pin)	3191-06P	412832-12	1	1	1	1	1	1	1			
17	Receptacle Housing (6 Pin)	3191-06R1	412831-12	1	1	1	1	1	1	1			
18	Threaded Insert	M5	4A0407-01	1	1	1	1	1	1	1			
19	Truss Head Screw	5x10, SS	7C32-0510	1	1	1	1	1	1	1			
20	Relay – Door Switch	FH1-AAC(-HD) FH2-AAC(-HD)	4A2268-01	1	-								
			4A2607-01		1	1	1	1	1	1	1		
21	Tapping Screw	3x8	431415-01	2	2	2	2	2	2	2			
22	Bushing	SB-625-8	420470-01	2	2	2	2	2	2	2			
23	Capacitor – Run	FH1-AAC(-HD)	439943-04	1	-								
			3A2005-08		1	1	1	1	1	1	1		
		FH2-AAC(-HD)	439943-02	1	-								
			3A2005-06		1	1	1	1	1	1	1	1	
24	Capacitor – Start	FH1-AAC(-HD) FH2-AAC(-HD)	3A0076-06	1	1	1	1	1	1	1	1		
			3A0076-07	1	1	1	1	1	1	1	1		
25	Starter	FH1-AAC(-HD) FH2-AAC(-HD)	4A1107-03	1	1	1	1	1	1	1	1		
			434172-01	1	1	1	-						
			4A1107-13					1	1	1	1		
26	Tapping Screw	3x8	431415-01	1	1	1	1	1	1	1			
27	Strap	FH1-AAC(-HD)	434580-08	1	1	1	1	1					
			434580-14							1	1		
		FH2-AAC(-HD)	434580-20	1	1	1	1	1	1	1	1		
28	Tapping Screw	3x8	431415-01	1	1	1	1	1	1	1			
29	Relay – Defrost	-	4A2266-01	1	1	1	1	1	1	1			
30	Tapping Screw	3x8	431415-01	2	2	2	2	2	2	2			
31	Bracket – Fuse	GS	4A3359-01					1	1	1			

Title: E. Control Box Assembly Model: FH1-AAC(-HD), FH2-AAC(-HD)												
Index No.	Description	Material or Model Number	Part Number	Required Number								
				K-0 to M-5	M-6 to M-8	N-5	P-5	P-6 P-7	Q-5	Q-6		
32	T2 Screw	4x8, SS	7P32-0408					2	2	2		
33	Fuse Holder	HTB92I	4A0892-01					1	1	1		
34	Fuse	AGC-55A250V	4A0893-09					1	1	1		

F. Fan-Evaporator Assembly

FH1-AAC(-HD)

K-0, L-0, L-5, M-5

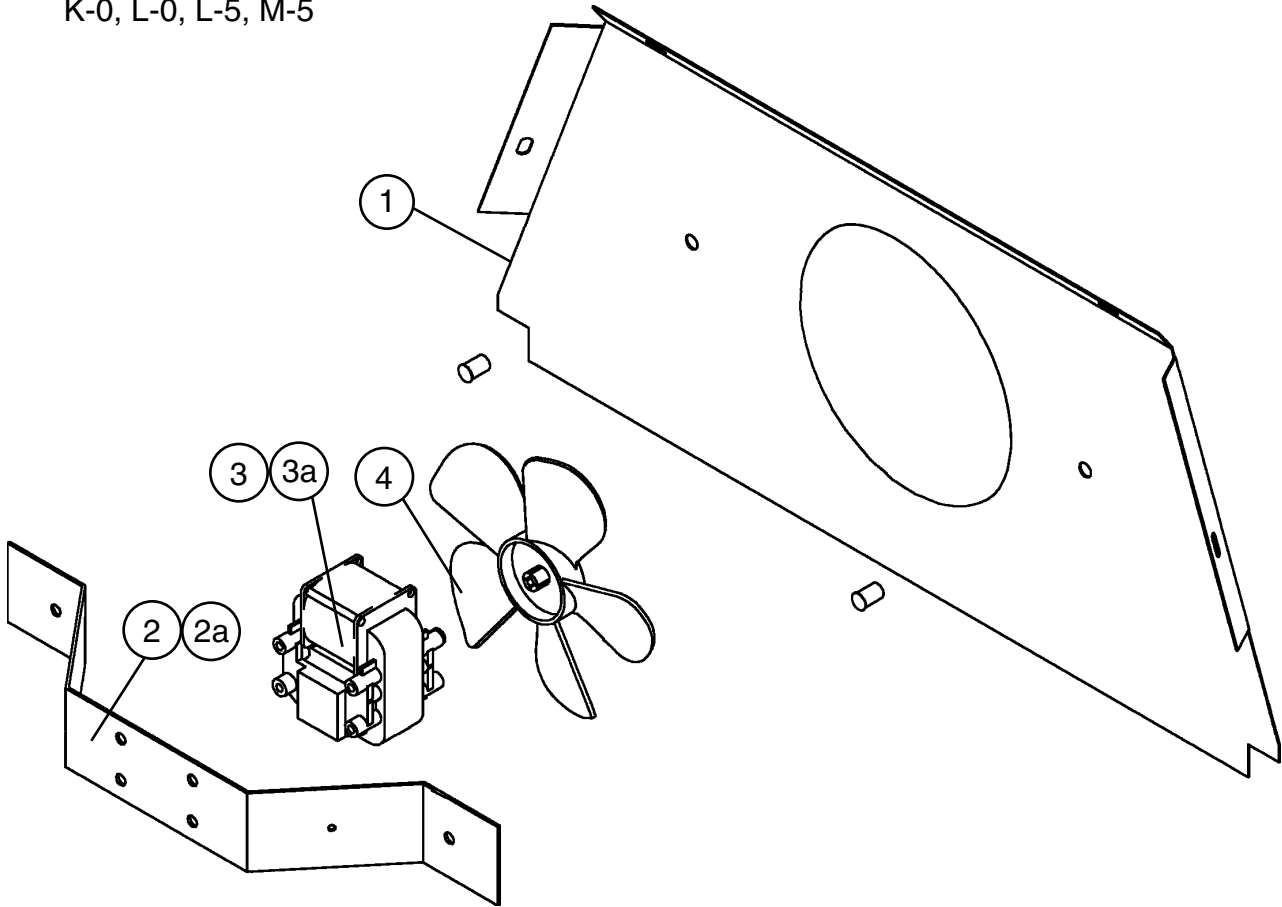

F. Fan-Evaporator Assembly

FH1-AAC(-HD)

M-6, M-7, N-5, N-6, P-5, P-6, P-7, P-8, Q-5, Q-6

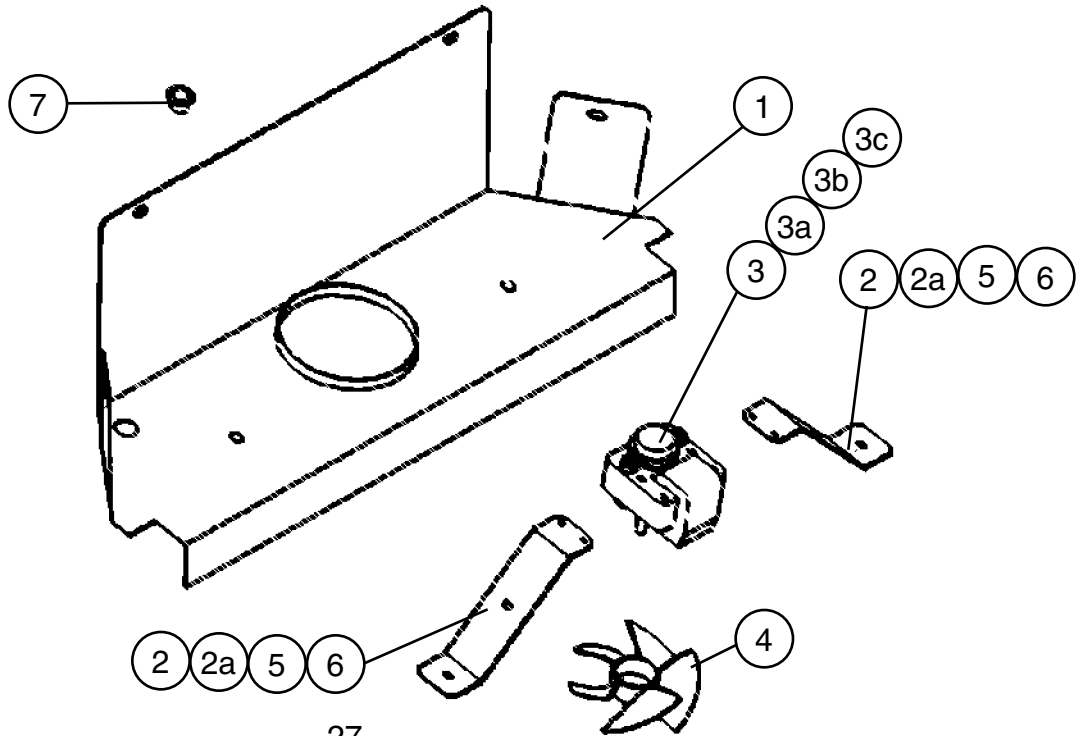

Title: F. Fan-Evaporator Assembly Model: FH1-AAC(-HD)														
Index No.	Description	Material or Model Number	Part Number	Required Number										
				K-0 to M-5	M-6 to P-5	P-6 to Q-6								
1	Shroud – Evaporator Fan	SS	2A0846-01	-										
			2A2565G01	1	-									
			2A2565G02		1									
2	Bracket – Fan Motor	-	3A2480-01	2	2									
2a	Truss Head Screw	5x12, SS	7C32-0512	2	2									
3	Motor – Fan Evap	JAKEL J238-100-10070	4A1132-01	-										
		-	4A2563-01	1	1									
3a	Truss Head Screw	4x40, SS	7C32-0440	4	4									
3b	Split Lock Washer	M4, SS	7L22-0400	4	4									
3c	Hex Nut	M4, SS	7N12-0400	4	4									
4	Blade – Fan	THORGREN 5562C3125L1	4A1131-01	-										
		-	4A2802-01	1	1									
5	Lock – Washer	-	4A0459-01	2	2									
6	Wire Tie (Twist)	-	4A1223-01	2	2									
7	Bushing	SB-625-8	420470-01	1	1									

Note: Parts are not interchangeable. For auxiliary codes prior to M-6, order HS-3545 and replace the entire assembly. For auxiliary codes M-6 and later, order appropriate part from this chart.

F. Evap-Shroud Assembly FH2-AAC(-HD)

K-0, L-5, M-5, M-6, M-7, M-8, N-5, N-6, P-5, P-6, P-7, P-8, Q-5, Q-6

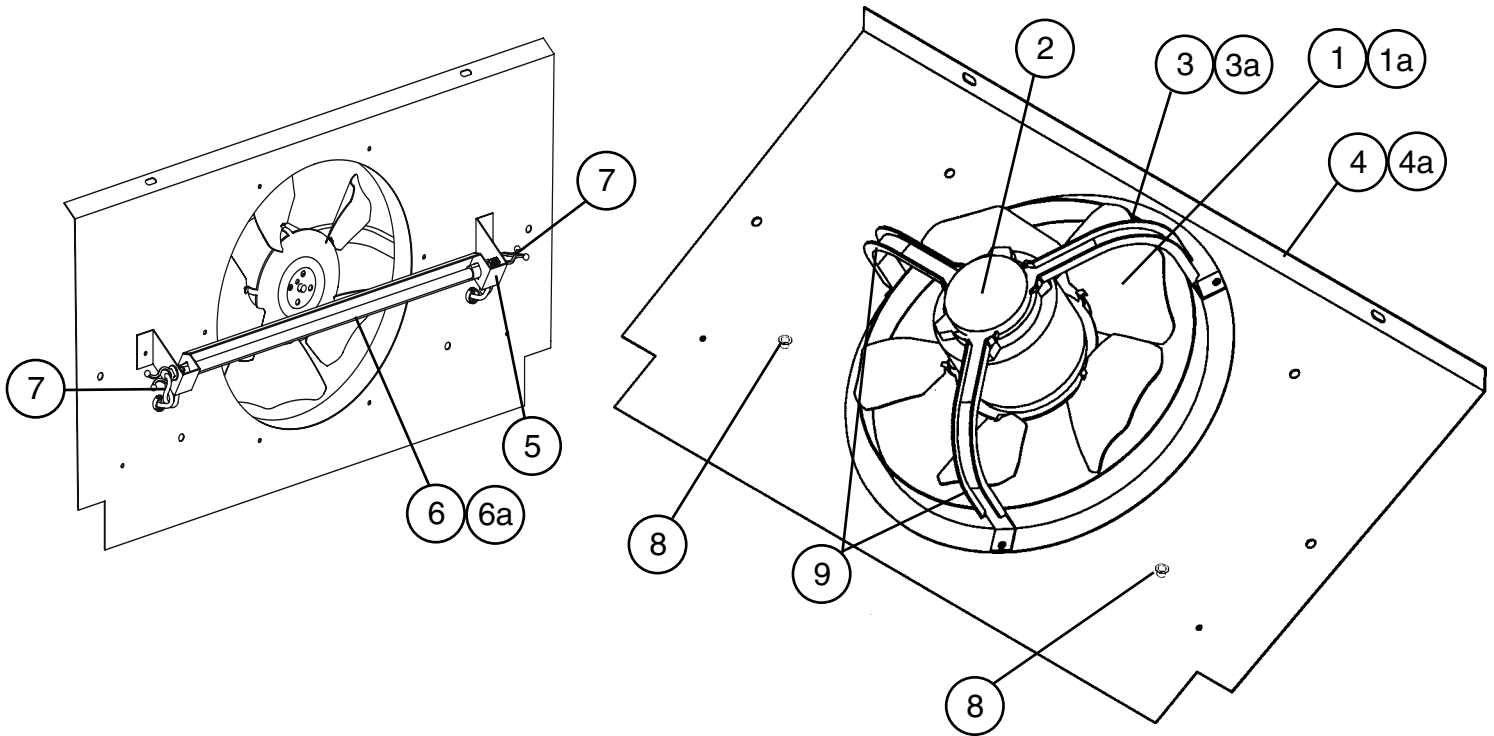

Title: F. Evap-Shroud Assembly Model: FH2-AAC(-HD)											
Index No.	Description	Material or Model Number	Part Number	Required Number							
				K-0 to P-5	P-6 to Q-6						
1	Blade – Fan (Pusher)	AIR DRIVE INC. AD9CCW30UBA	3A0438-01	1	1						
1a	Lock Washer		4A0459-01	1	1						
2	Motor – Evap Fan	MORRILL PSC4BE9BEA1	4A0413-01	1	1						
3	Orifice – Evap Fan	SS	4A0412-01	1	1						
3a	T2 Screw	4x8, SS	7P32-0408	3	3						
4	Shroud – Evap Fan	SS	1A0100-01	1	-						
4a	Hex Nut		4A1345-01	1	1						
5	Bracket – Heater Supply	-	3A3243-01		1						
6	Heater – Glass Tube	-	3A2335-02		1						
6a	T2 Screw	4x8	7P32-0408		2						
7	Wire Tie (Twist)	-	4A1223-01		4						
8	Bushing	-	428394-02		2						
9	Nylon Tie	CV-100	8911-0100		4						

G. Evaporator Assembly FH1-AAC(-HD)

K-0, L-0, L-5, M-5, M-6, M-7, N-5, N-6, P-5, P-6, P-7, P-8, Q-5, Q-6

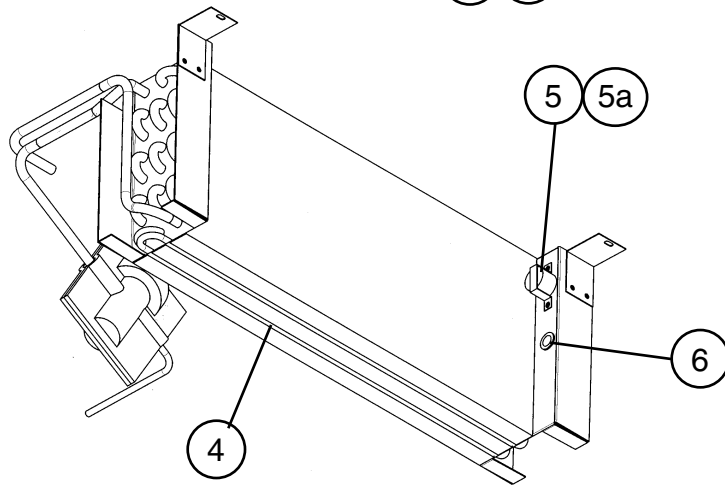
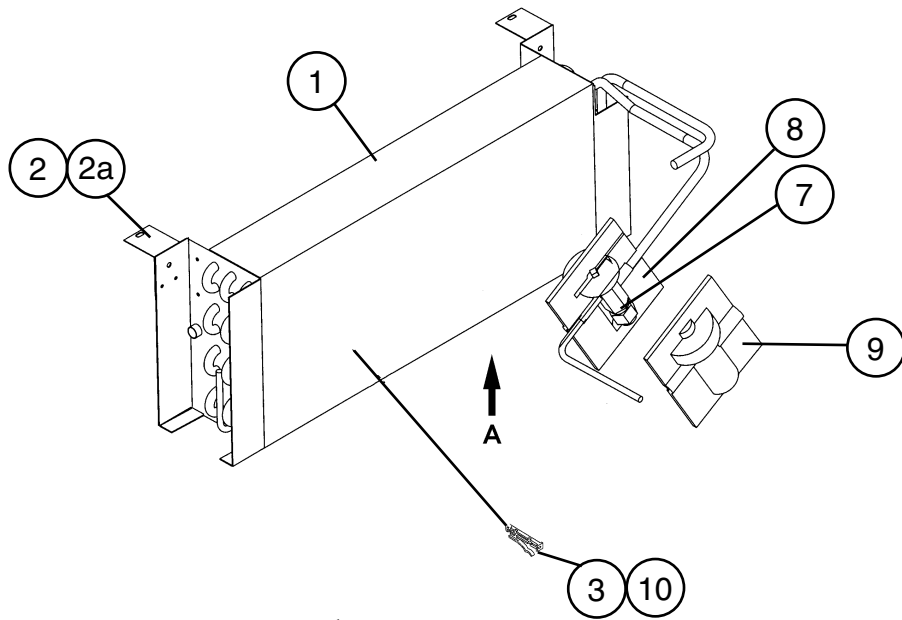

VIEW "A"

Title: G. Evaporator Assembly Model: FH1-AAC(-HD)												
Index No.	Description	Material or Model Number	Part Number	Required Number								
				K-0	L-0 to P-5	P-6 to Q-6						
1	Evaporator	-	2A0781-01	1	1	1						
2	Bracket – Evaporator	SS	4A2542-01	2	2	2						
2a	T2 Screw	4x8, SS	7P32-0408	4	4	4						
3	Thermistor – Defrost	Thermistor is to be replaced using kit HS-3540. Apply to all aux. codes.		-	-	-						
	Clip – Thermistor		4A3248G01	1	1	1						
4	Heater – Defrost	-	3A0846-01	1	1	1						
5	Thermistat – Defrost	-	4A0954-02	1	1	1						
5a	T2 Screw	4x8, SS	7P32-0408	2	2	2						
6	Bushing	0CB-500	428394-02	1	1	1						
7	Expansion Valve	-	4A1135-01	1	1	1						
8	Expansion Valve Cover (A)	-	3A0372-01	1	1	1						
9	Expansion Valve Cover (B)	-	3A0372-02	1	1	1						
10	Nylon Tie		8911-0150			1						

**G. Evaporator Assembly
FH2-AAC(-HD)**

K-0, L-5, M-5, M-6, M-7, M-8, N-5, N-6, P-5, P-6, P-7, P-8, Q-5, Q-6

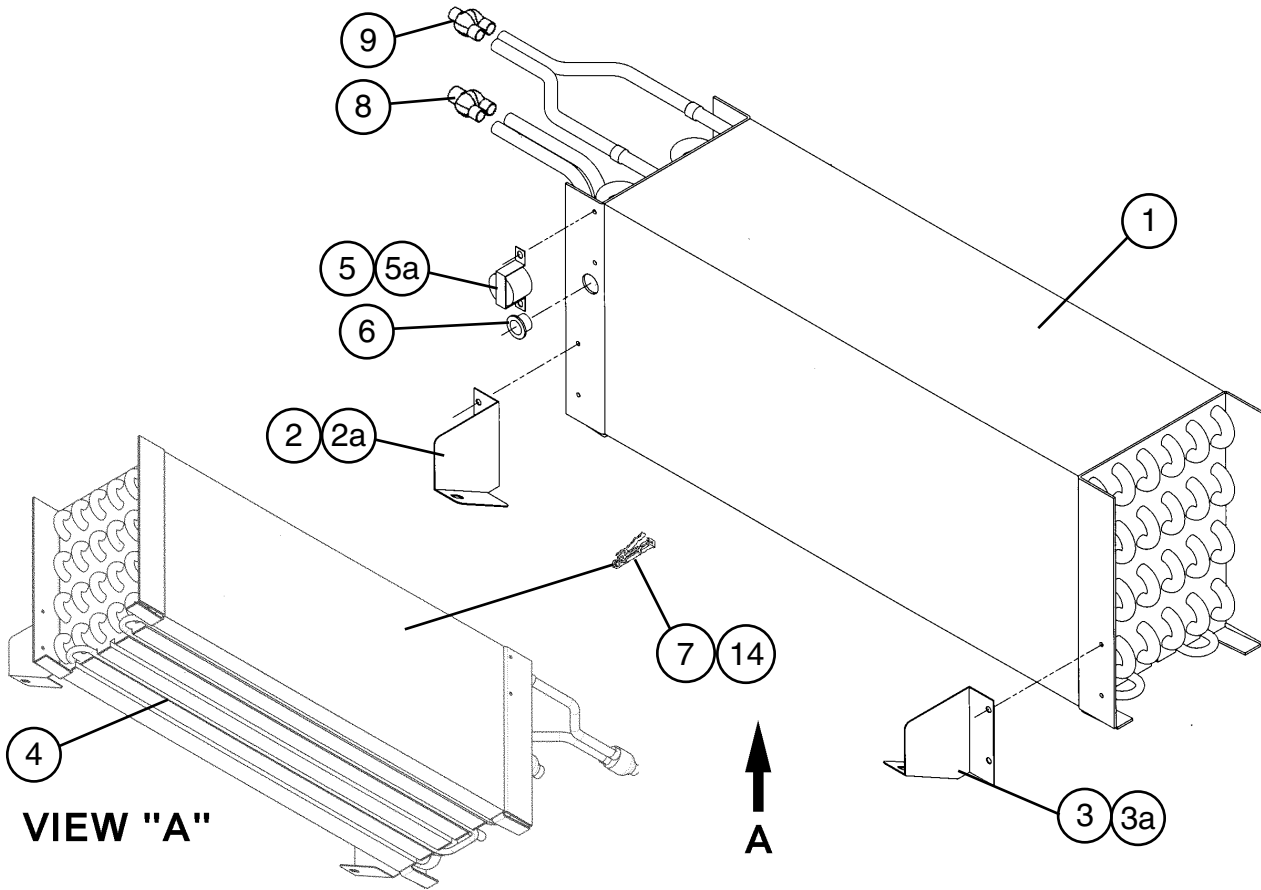

These additional parts added to FH2-AAC(-HD) Evaporator Assembly at aux. code M-6

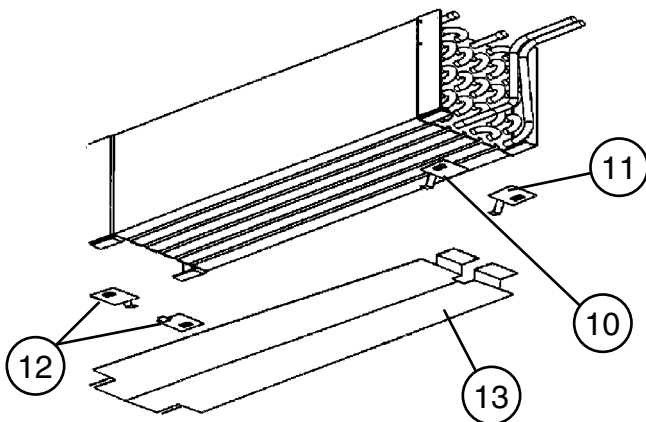

Title: G. Evaporator Assembly Model: FH2-AAC(-HD)												
Index No.	Description	Material or Model Number	Part Number	Required Number								
				K-0 to M-5	M-6 to P-5	P-6	P-7 to Q-6					
1	Evaporator	-	2A0636-01	1	1	1	1					
2	Bracket-Evap Shroud (R)	SS	4A0545-01	1	1	-						
2a	T2 Screw	4x8, SS	7P32-0408	2	2	-						
3	Bracket-Evap Shroud (L)	SS	4A0548-01	1	1	-						
3a	T2 Screw	4x8, SS	7P32-0408	2	2	-						
4	Heater – Defrost	-	3A0591-01	1	1	1	1					
5	Thermostat – Defrost	-	4A0954-02	1	1	1	1					
5a	T2 Screw	4x8, SS	7P32-0408	2	2	2	2					
6	Bushing	-	420470-01	1	1	1	1					
7	Thermistor – Defrost	Thermistor is to be replaced using kit HS-3540. Apply to all aux. codes.		-	-	-	-					
	Thermistor – Clip		320418-01	1	1	1	1					
8	“Y” Joint	-	4A1687-03	1	1	1	1					
9	“Y” Joint	-	4A1687-02	1	1	1	1					
10	Clip – Support Evap (A)	-	4A2826-01		1	1	1					
11	Clip – Support Evap (B)	-	4A2827-01		1	1	1					
12	Clip – Support Evap (C)	-	4A2828-01		2	2	2					
13	Shield – Heat	-	3A1853G01		1	1	1					
14	Nylon Tie	-	8911-0150				1					

Installation Instructions for Parts 10, 11, 12, & 13

1. The original heat shield must be removed. This can be done by lifting the evaporator up and sliding the heat shield out.
2. The new heat shield (part #13) is then installed in the rotocast drain pan.
3. The clips are then slid onto the end plate on the evaporator. Support clips (part #12) are installed onto the hairpin end of the evaporator as shown in the illustration.
4. The other support clips (parts #10 and #11) are installed on the return bend end (same side as inlet and outlet tubes) as shown in the illustration.

NOTE: All clips are shown in the illustration in the correct orientation for installation. The parts are slid onto the evaporator bracket using the tab on the support clip.

H. Condenser Assembly

FH1-AAC(-HD)

K-0, L-0, L-5, M-5, M-6, M-7, N-5, N-6, P-5, P-6, P-7, P-8, Q-5, Q-6

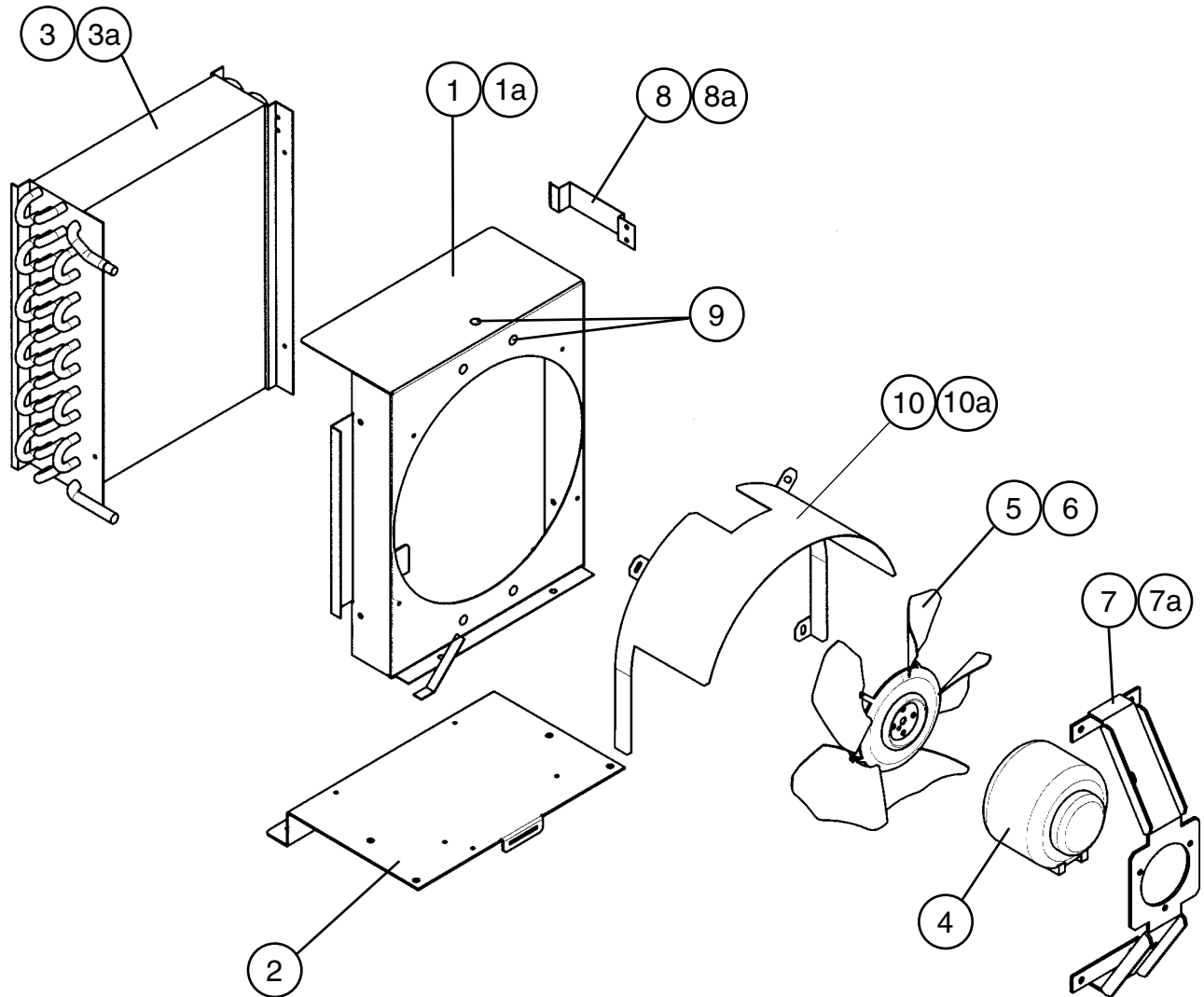

Title: H. Condenser Assembly Model: FH1-AAC(-HD)											
Index No.	Description	Material or Model Number	Part Number	Required Number							
				K-0 to N-5	N-6 to Q-6						
1	Shroud – Condenser	GS	2A1685-02	1	-						
			2A2722-02		1						
1a	T2 Screw	4x8, SS	7P32-0408	4	4						
2	Base – Condenser	GS	2A1027G01	1	-						
			2A2724G01		1						
3	Condenser	-	2A0782-01	1	1						
3a	T2 Screw	4x8, SS	7P32-0408	4	4						
4	Fan Motor	-	4A1179-01	1	1						
5	Blade – Cond Fan	-	3A0608-01	1	1						
6	Hex Nut	PS	4A1345-01	1	1						
7	Bracket – Condenser Fan	GS	3A1564-01	1	1						
7a	Truss Head Screw	5x12, SS	7C32-0512	4	4						
8	Retainer – Filter	GS	4A0790-01	1	1						
8a	T2 Screw	4x8, SS	7P32-0408	2	2						
9	Threaded Insert	-	4A0407-01	5	5						
10	Extension – Condenser Shroud	-	3A1747-01	1	1						
10a	T2 Screw	4x8, SS	7P32-0408	4	4						

H. Condenser Assembly FH2-AAC(-HD)

K-0, L-5, M-5, M-6, M-7, M-8, N-5, N-6, P-5, P-6, P-7, P-8, Q-5, Q-6

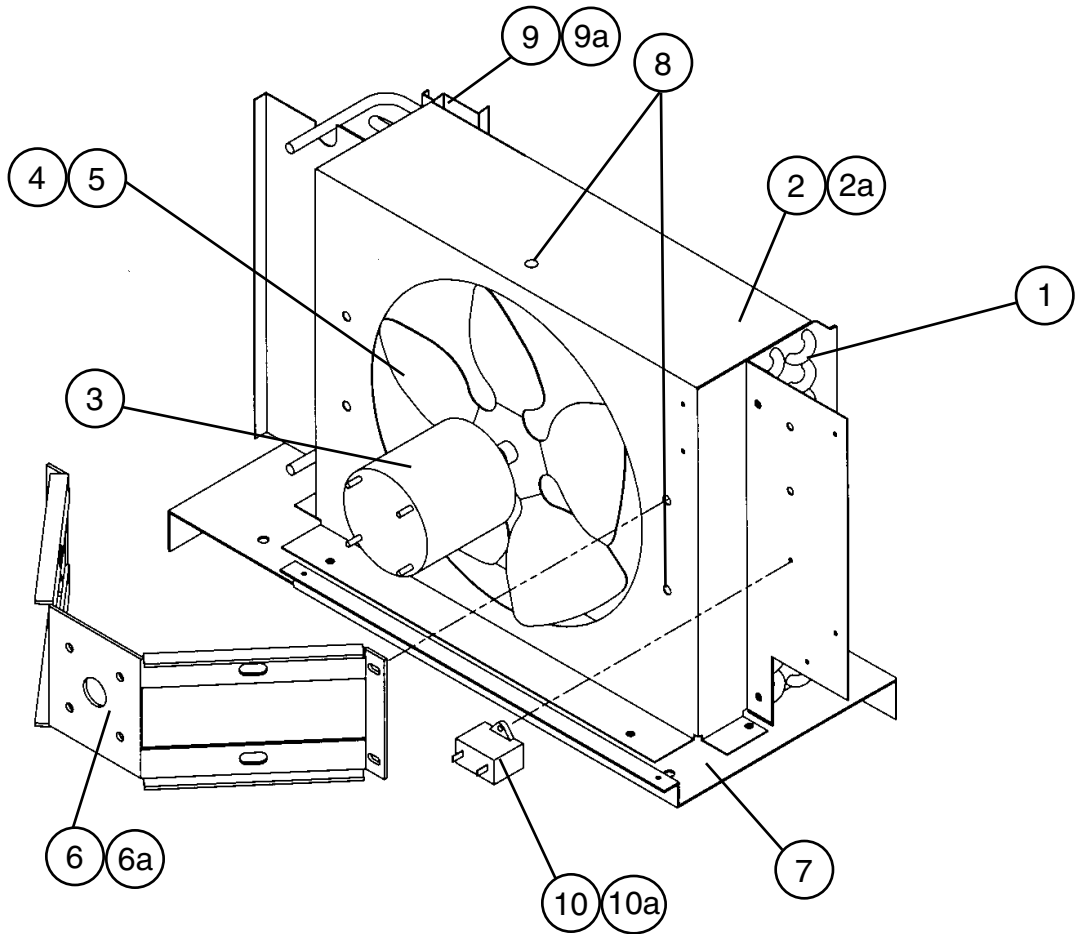

Title: H. Condenser Assembly Model: FH2-AAC(-HD)				Required Number									
Index No.	Description	Material or Model Number	Part Number	K-0	P-6								
				to P-5	to Q-6								
1	Condenser	-	2A0638-01	1	1								
2	Shroud – Condenser	GS	2A1491-01	1	1								
2a	T2 Screw	4x8, SS	7P32-0408	8	-								
		4x12, SS	7P32-0412		8								
3	Fan Motor	-	440911-01	1	-								
			4A3158-01		1								
4	Fan Blade (Puller)	-	4a1865-01	1	1								
5	Self – Locking Nut	8 x 32	7N2110832	4	4								
6	Bracket – Cond Fan Mtr	GS	2A1668-01	1	1								
6a	Truss Head Screw	5x12	7C32-0512	4	4								
7	Base – Condenser	GS	2A1217-01	1	1								
8	Threaded Insert	-	4A0407-01	5	5								
9	Retainer – Filter	-	4A2138-01	1	1								
9a	T2 Screw	4x8, SS	7P32-0408	2	2								
10	Capacitor	-	443192-02	1	1								
10a	T2 Screw	4X8, SS	7P32-0408	1	1								

J. Body-Prefinal FH1-AAC(-HD)

K-0, L-0, L-5, M-5, M-6, M-7, N-5, N-6, P-5, P-6, P-7, P-8, Q-5, Q-6

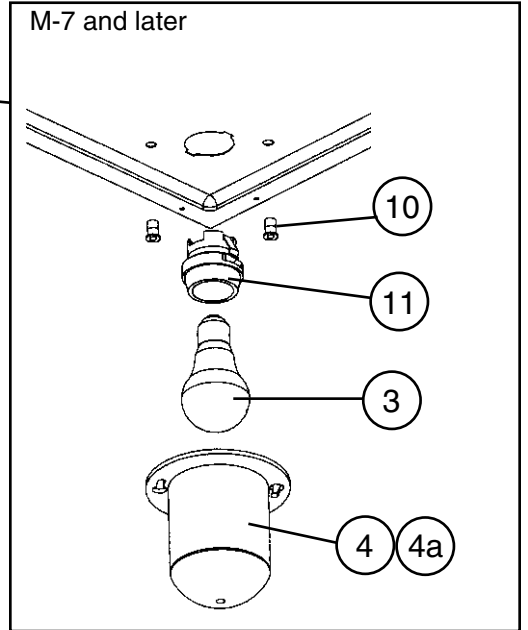
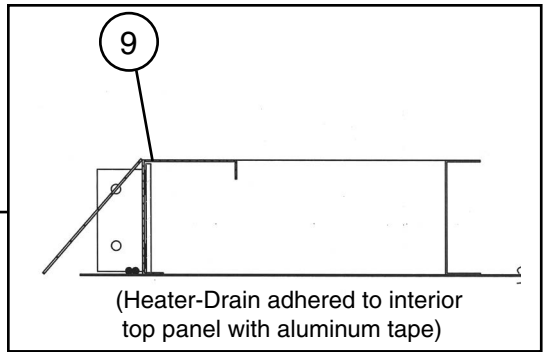
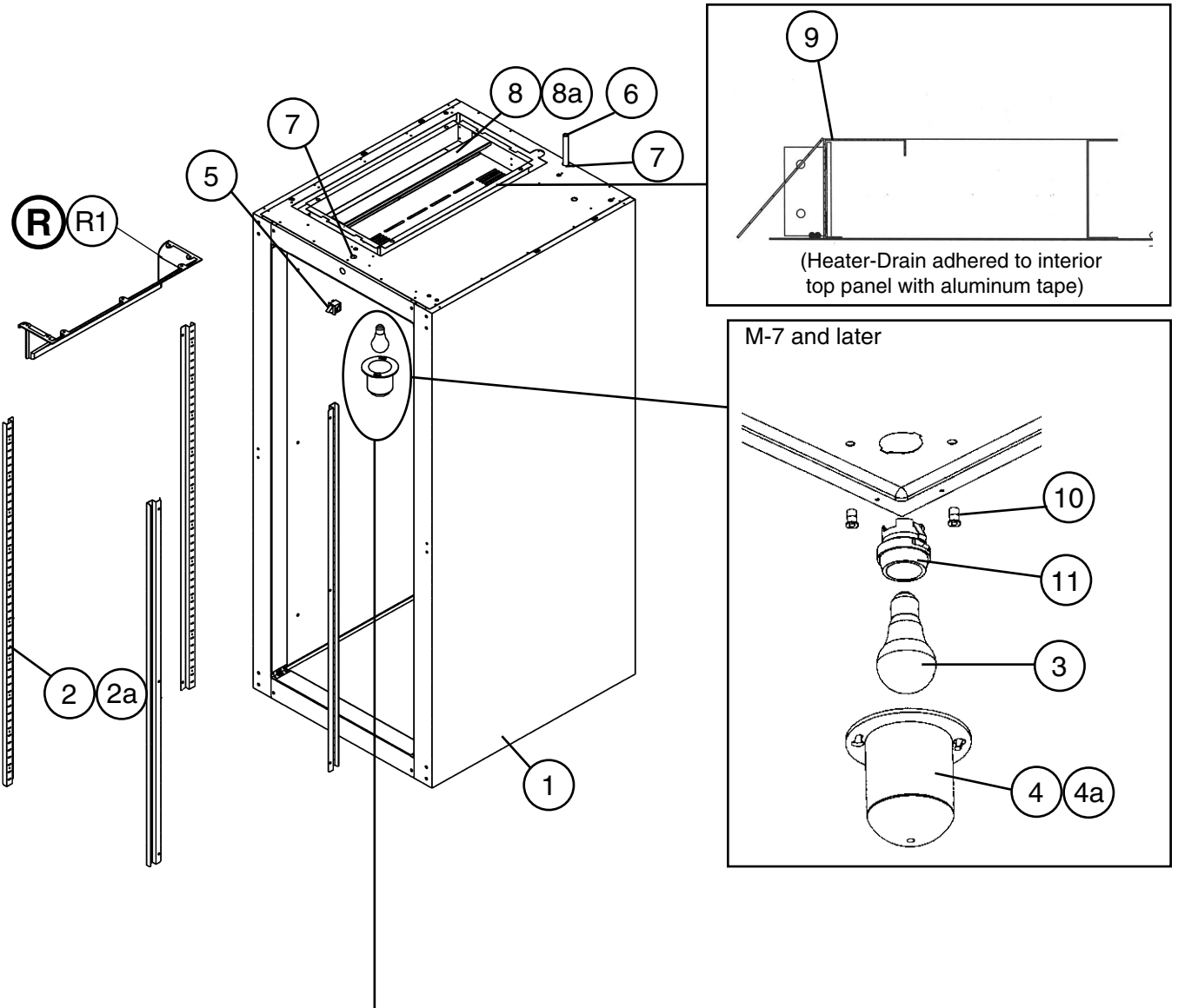

M-6 and earlier

The santoprene light socket was changed to a porcelain lampholder at M-7. This change is non-interchangeable. If the light socket is not operating on a unit with a santoprene light socket, Hoshizaki recommends replacement with HS-3554.

Note:

Parts 3, 4, 4a, 4b and 4c are not included in HS-3554; they are shown for reference only.

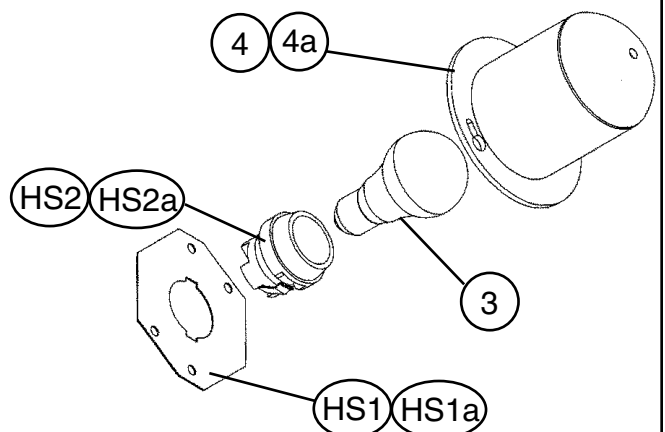

Title: J. Body-Prefinal Model: FH1-AAC(-HD)												
Index No.	Description	Material or Model Number	Part Number	Required Number								
				K-0 to M-6	M-7 to P-5	P-6 to Q-6						
R	Distributor – Air Top Assm		2A0438G01	1	1	-						
			2A3086A01			1						
R1	T2 Screw	4x8, SS	7P32-0408	7	7	7						
1	Cabinet Prefoam	FH1-AAC	1A0173G04	1	1	1						
		FH1-AAC-HD	1A0353G03	1	1	1						
2	Pilaster	AL	3A0145-21	4	4	4						
2a	Truss Head Screw	5x10, SS	7C32-0510	12	12	12						
3	Bulb – Light	-	4A0437-01	1	-							
		-	4A2420-01		1	1						
4	Shield – Light	STANDARD KEIL, 2778-1010-3000	4A0465-01	1	1	1						
4a	Cheese Head Screw	5x12, SS	7C52-0512	2	2	2						
4b	Washer	8, SS	7W22-0800	2	-							
5	Switch – Door	NYLON	3A1826-01	1	1	1						
6	Vinyl Hose	L=1700	7730I3812	1	1	1						
7	Bushing	OCB-875	428394-04	2	2	2						
8	Divider – Air	AL	2A0199-21	1	1	1						
8a	T2 Screw	4x8, SS	7P32-0408	4	4	4						
9	Heater – Drain	10758 25W115V	4A2975-03			1						
10	Threaded Insert (Wide)		4A0839-01		2	2						
11	Lampholder	-	4A2862-01		1	1						

HS-3554-Lampholder Conversion Kit												
Index No.	Description	Material or Model Number	Part Number	Required Number								
				M-6 and earlier								
HS1	Plate – Lampholder Mount	SS	4A2880-01	1								
HS1a	Cheese Head Screw	SS	7C52-0512	2								
HS2	Lampholder		4A2862-01	1								
HS2a	Terminal – Flag	DNFR18-250FIBK	8101-18FJ	2								

J. Body-Prefinal FH2-AAC(-HD)

K-0, L-5, M-5, M-6, M-7, M-8, N-5, N-6, P-5, P-6, P-7, P-8, Q-5, Q-6

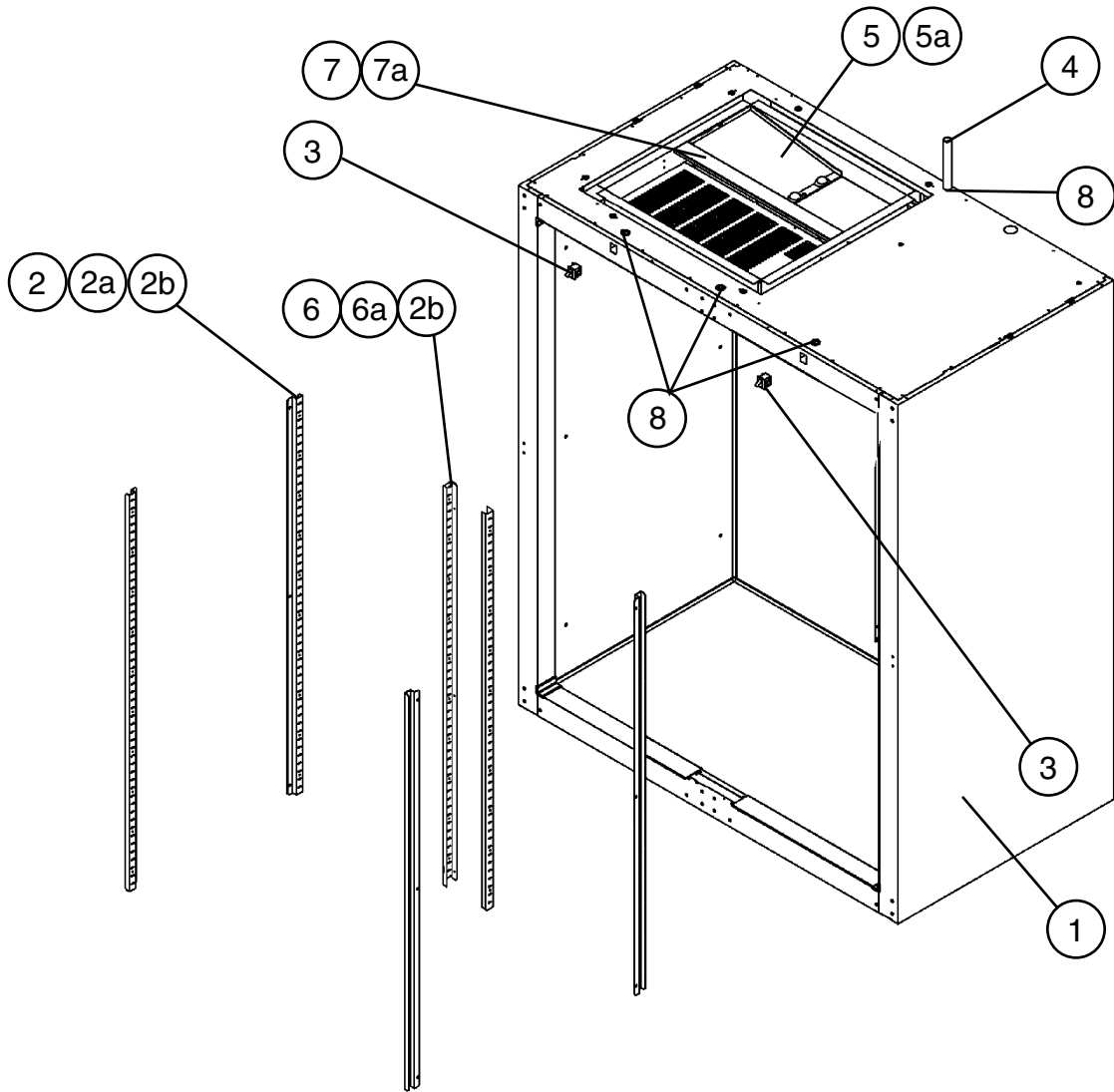

Title: J. Body-Prefinal Model: FH2-AAC(-HD)											
Index No.	Description	Material or Model Number	Part Number	Required Number							
				K-0 to P-6	P-7 to Q-6						
1	Cabinet – Prefoam	-	2A0706G05	1	1						
2	Pilaster	AL	3A0145-21	4	4						
2a	Truss Head Screw	5x10, SS	7C32-0510	12	12						
2b	Threaded Insert	M5	4A0407-01	18	18						
3	Switch – Door	NYLON	3A1826-01	2	2						
4	Vinyl Hose	L=1700	7730I3812	1	1						
5	Baffle – Air	-	2A0625-01	1	1						
5a	Truss Head Screw	5x10, SS	7C32-0510	2	2						
6	Pilaster – Mullion	AL	2A0205-21	2	-						
			2A3246-21		2						
6a	Truss Head Screw	5x10, SS	7C32-0510	6	6						
7	Divider – Air	AL	2A0199-21	1	1						
7a	T2 Screw	4x8, SS	7P32-0408	4	4						
8	Bushing	OCB-875	428394-04	4	4						

K. Door-Right

FH1-AAC, FH2-AAC

K-0, L-5, M-5, M-6, M-7, M-8, N-5, N-6, P-5, P-6, P-7, P-8, Q-5, Q-6

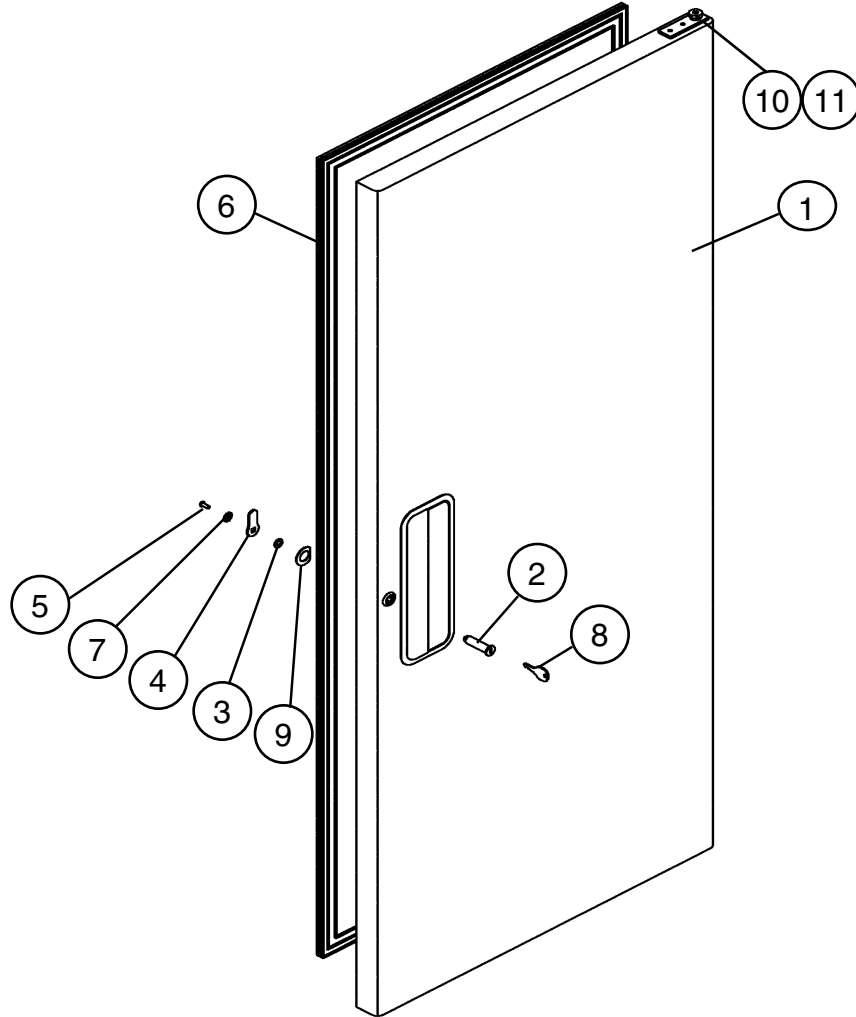

Title: K. Door-Right Model: FH1-AAC, FH2-AAC					Required Number								
Index No.	Description	Material or Model Number	Part Number	K-0 to Q-6									
1	Door – Prefoam (R)	-	1A0317G03	1									
2	Lock – Tumbler	M4-5813-001	4A0462-01	1									
3	Lock – Stop Washer	M5-8060-103	4A0458-01	1									
4	Cam – Door Lock	P.S	4A0228-01	1									
5	Lock – Screw	SS	4A0461-01	1									
6	Gasket – Door	Jarrow #P-2209 244A GRAY	3A0273-01	1									
7	Lock Washer	SS	4A0459-01	1									
8	Lock – Key	M5-0680-111	4A0460-01	1									
9	Washer – Door Lock	SS	4A0670-01	1									
10	Hinge – Spring		4A3312-01	1									
11	Hinge – Spring Cart		4A0438-01	1									

L. Door-Left FH2-AAC

L-5, M-5, M-6, M-7, M-8, N-5, N-6, P-5, P-6, P-7, Q-5, Q-6

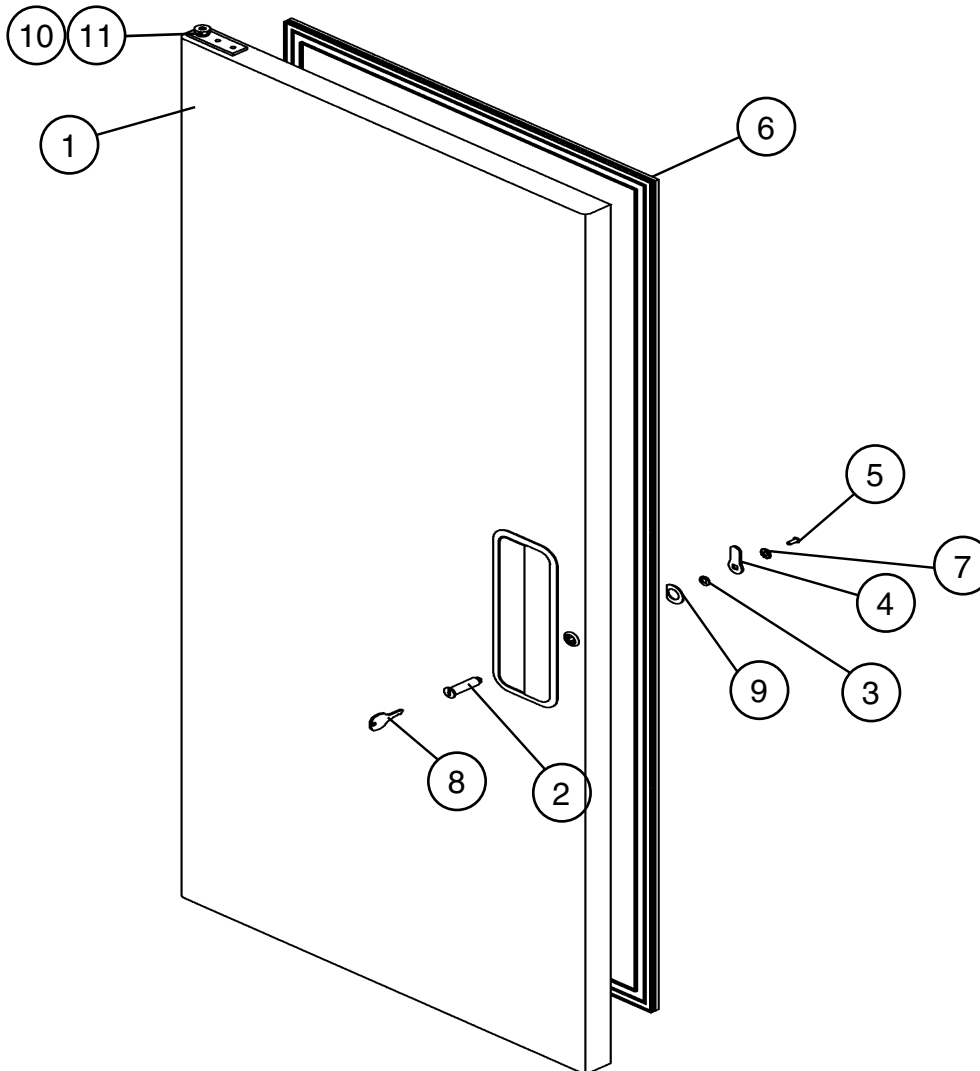

Title: L. Door-Left Model: FH2-AAC					Required Number								
Index No.	Description	Material or Model Number	Part Number	L-5 to Q-6									
1	Door – Prefoam (L)	-	1A0317G04	1									
2	Lock – Tumbler	M4-5813-001	4A0462-01	1									
3	Lock – Stop Washer	M5-8060-103	4A0458-01	1									
4	Cam – Door Lock	P.S	4A0228-01	1									
5	Lock – Screw	SS	4A0461-01	1									
6	Gasket – Door	JARROW #P-2209 244A GRAY	3A0273-01	1									
7	Lock Washer	SS	4A0459-01	1									
8	Lock – Key	M5-0680-111	4A0460-01	1									
9	Washer – Door Lock	SS	4A0670-01	1									
10	Hinge – Spring		4A3312-02	1									
11	Hinge – Spring Cart		4A0438-02	1									

M. Door-Half (UR)

FH1-AAC-HD, FH2-AAC-HD

K-0, L-0, L-5, M-5, M-6, M-7, N-6, P-5, P-6, P-7, P-8, Q-5, Q-6

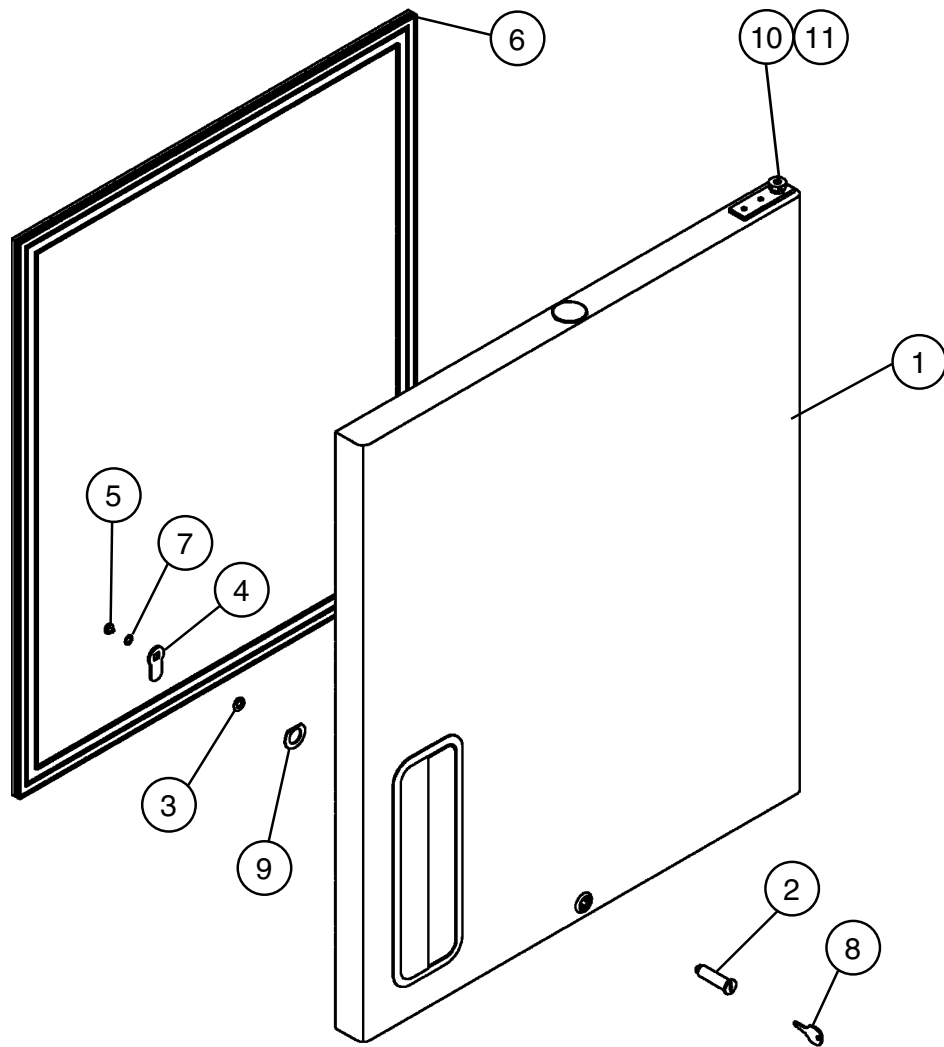

Title: M. Door-Half (UR) Model: FH1-AAC-HD, FH2-AAC-HD																	
Index No.	Description	Material or Model Number	Part Number	Required Number													
				K-0 to Q-6													
1	Door – Prefoam (UR)	-	1A0325G03	1													
2	Lock – Tumbler	M4-5813-001	4A0462-01	1													
3	Lock – Stop Washer	M5-8060-103	4A0458-01	1													
4	Cam – Door Lock	P.S	4A0228-01	1													
5	Lock – Screw	SS	4A0461-01	1													
6	Gasket – Door (Half)	JARROW #P-2209 244A GRAY	3A0273-02	1													
7	Lock Washer	SS	4A0459-01	1													
8	Lock – Key	M5-0680-111	4A0460-01	1													
9	Washer – Door Lock	SS	4A0670-01	1													
10	Hinge – Spring		4A3312-01	1													
11	Hinge – Spring Cart		4A0438-01	1													

N. Door-Half (LR)

FH1-AAC-HD, FH2-AAC-HD

K-0, L-0, L-5, M-5, M-6, M-7, N-6, P-5, P-6, P-7, P-8, Q-5, Q-6

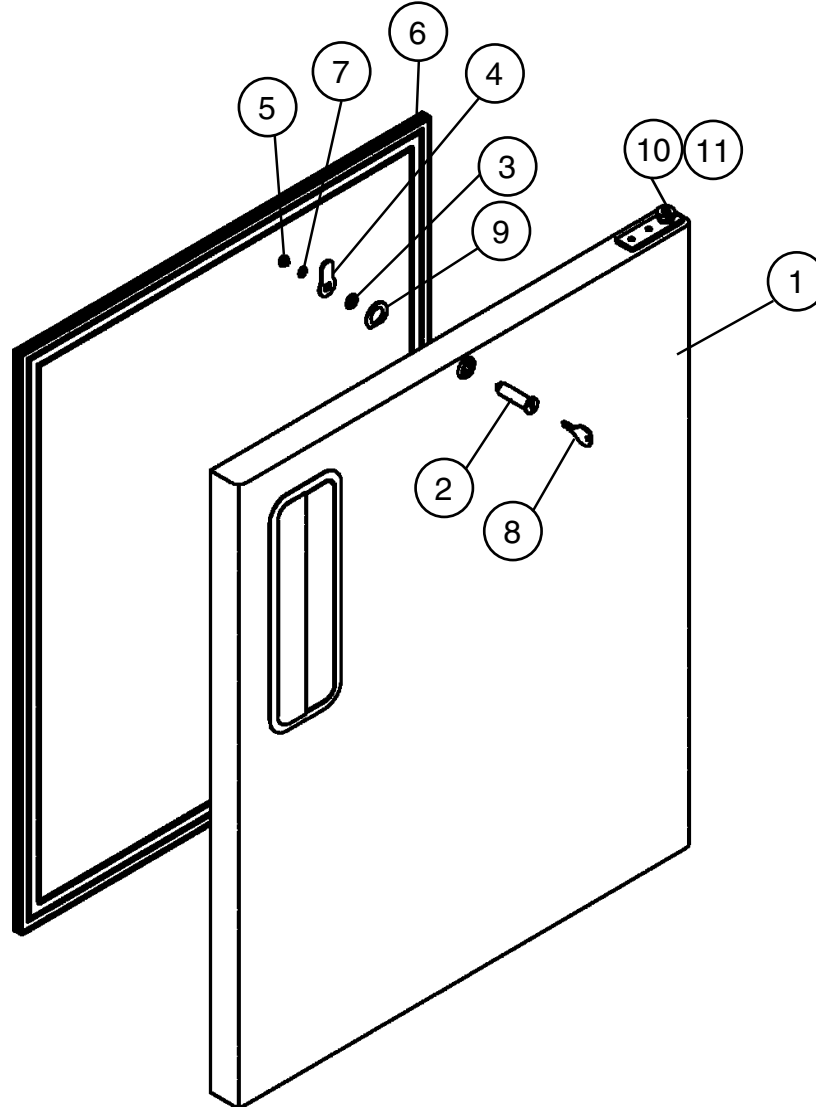

Title: N. Door Half (LR) Model: FH1-AAC-HD, FH2-AAC-HD											
Index No.	Description	Material or Model Number	Part Number	Required Number							
				K-0 to Q-6							
1	Door – Prefoam (LR)	-	1A0323G03	1							
2	Lock – Tumbler	M4-5813-001	4A0462-01	1							
3	Lock – Stop Washer	M5-8060-103	4A0458-01	1							
4	Cam – Door Lock	P.S	4A0228-01	1							
5	Lock – Screw	SS	4A0461-01	1							
6	Gasket – Door (Half)	JARROW P-2209 244A GRAY	3A0273-02	1							
7	Lock Washer	SS	4A0459-01	1							
8	Lock – Key	M5-0680-111	4A0460-01	1							
9	Washer – Door Lock	SS	4A0670-01	1							
10	Hinge – Spring		4A3312-01	1							
11	Hinge – Spring Cart		4A0438-01	1							

**P. Door-Half (UL)
FH2-AAC-HD**

K-0, L-5, M-6, N-6, P-5, P-6, P-7, P-8, Q-5, Q-6

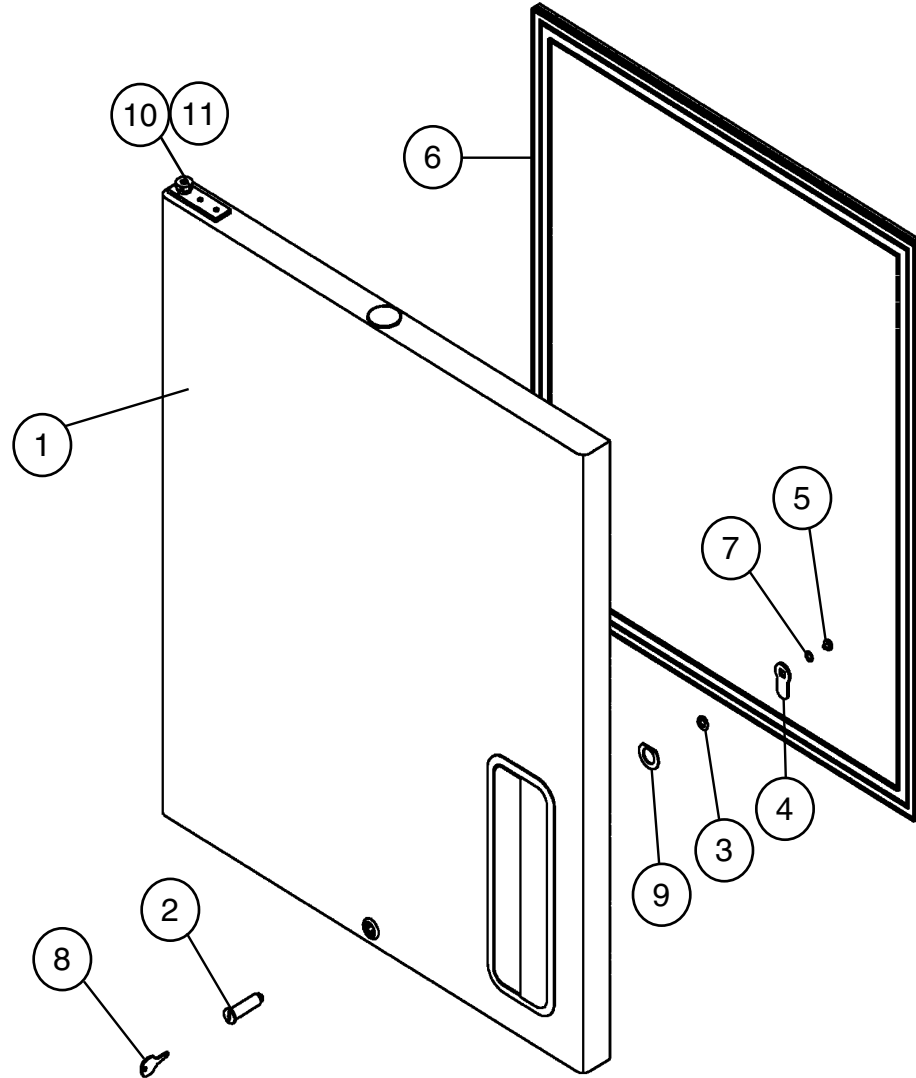

Title: P. Door-Half (UL) Model: FH2-AAC-HD														
Index No.	Description	Material or Model Number	Part Number	Required Number										
				K-0 to Q-6										
1	Door – Prefoam (UL)	-	1A0323G04	1										
2	Lock – Tumbler	M4-5813-001	4A0462-01	1										
3	Lock – Stop Washer	M5-8060-103	4A0458-01	1										
4	Cam – Door Lock	P.S	4A0228-01	1										
5	Lock – Screw	SS	4A0461-01	1										
6	Gasket – Door (Half)	Jarrow #P-2209 244A GRAY	3A0273-02	1										
7	Lock Washer	SS	4A0459-01	1										
8	Lock – Key	M5-0680-111	4A0460-01	1										
9	Washer – Door Lock	SS	4A0670-01	1										
10	Hinge – Spring		4A3312-02	1										
11	Hinge – Spring Cart		4A0438-02	1										

Q. Door-Half (LL)
FH2-AAC-HD

K-0, L-5, M-6, N-6, P-5, P-6, P-7, P-8, Q-5, Q-6

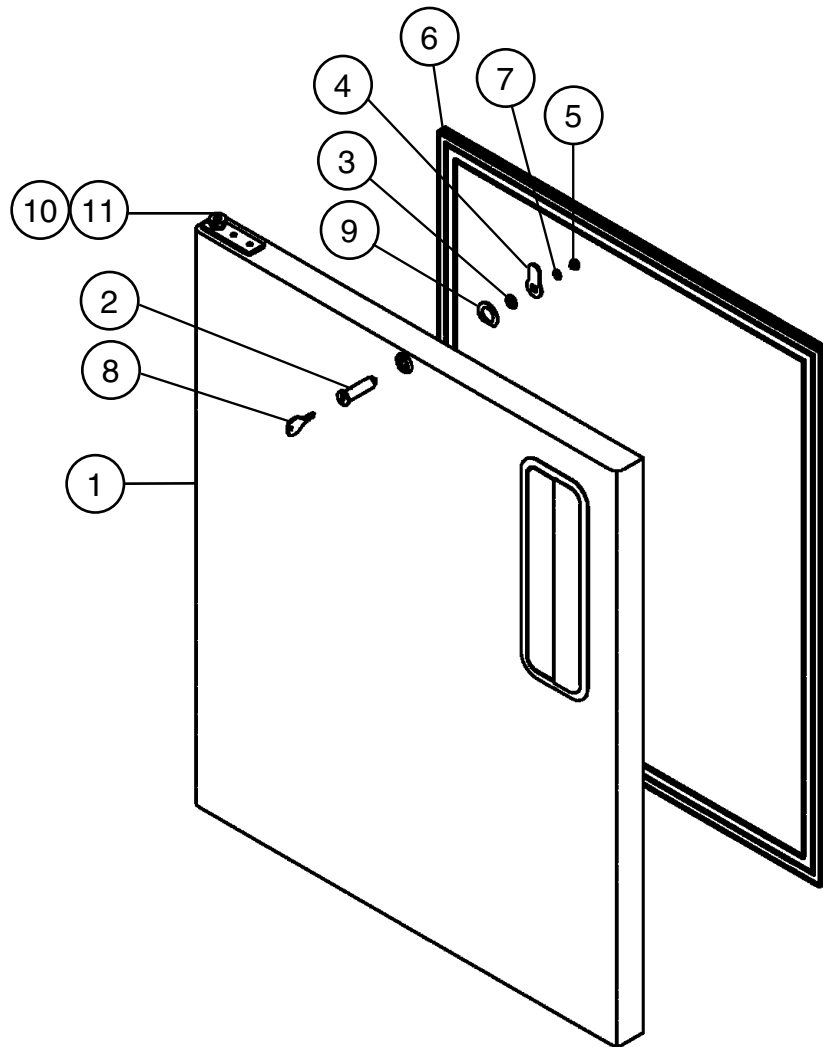

Title: Q. Door-Half (LL) Model: FH2-AAC-HD																			
Index No.	Description	Material or Model Number	Part Number	Required Number															
				K-0 to Q-6															
1	Door – Prefoam (LL)	-	1A0325G04	1															
2	Lock – Tumbler	M4-5813-001	4A0462-01	1															
3	Lock – Stop Washer	M5-8060-103	4A0458-01	1															
4	Cam – Door Lock	P.S	4A0228-01	1															
5	Lock – Screw	SS	4A0461-01	1															
6	Gasket – Door (Half)	Jarrow #P-2209 244A GRAY	3A0273-02	1															
7	Lock Washer	SS	4A0459-01	1															
8	Lock – Key	M5-0680-111	4A0460-01	1															
9	Washer – Door Lock	SS	4A0670-01	1															
10	Hinge – Spring		4A3312-02	1															
11	Hinge – Spring Cart		4A0438-02	1															

R. Distributor-Air Top Assembly

FH1-AAC-(HD)

K-0, L-5, M-6, N-6, P-5, P-6, P-7, P-8, Q-5, Q-6

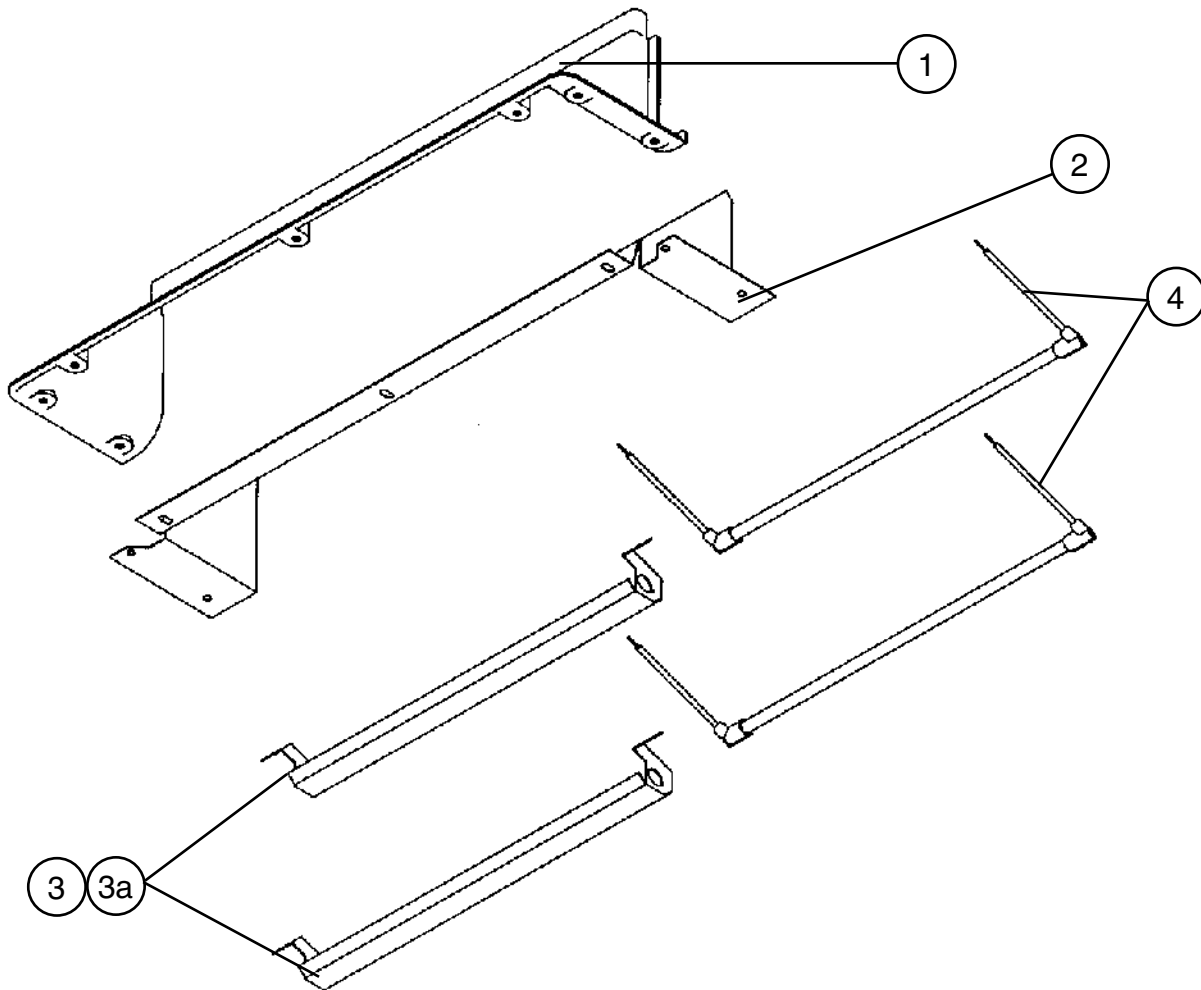

Title: R. Distributor-Air Top Assembly		Model: FH1-ACC(-HD)		Required Number								
Index No.	Description	Material or Model Number	Part Number	K-0 to P-5	P-6 P-7	P-8 Q-6						
1	Distributor – Air (Top)	ABS	2A0610-01	1								
			2A0610-03		1	-						
			2A0610-04				1					
2	Shield – Duct		2A3085-01		1	-						
			2A3392-01				1					
3	Bracket – Heater Supply		3A3096G01		1	1						
3a	Truss Head Screw	5x12	7C32-0512		4	6						
4	Heater – Glass Tube		3A2335-02		2	2						

S. Mullion-Horizontal
FH1-AAC-HD

K-0, L-0, L-5, M-5, M-6, M-7, N-6, P-5, P-6, Q-5, Q-6

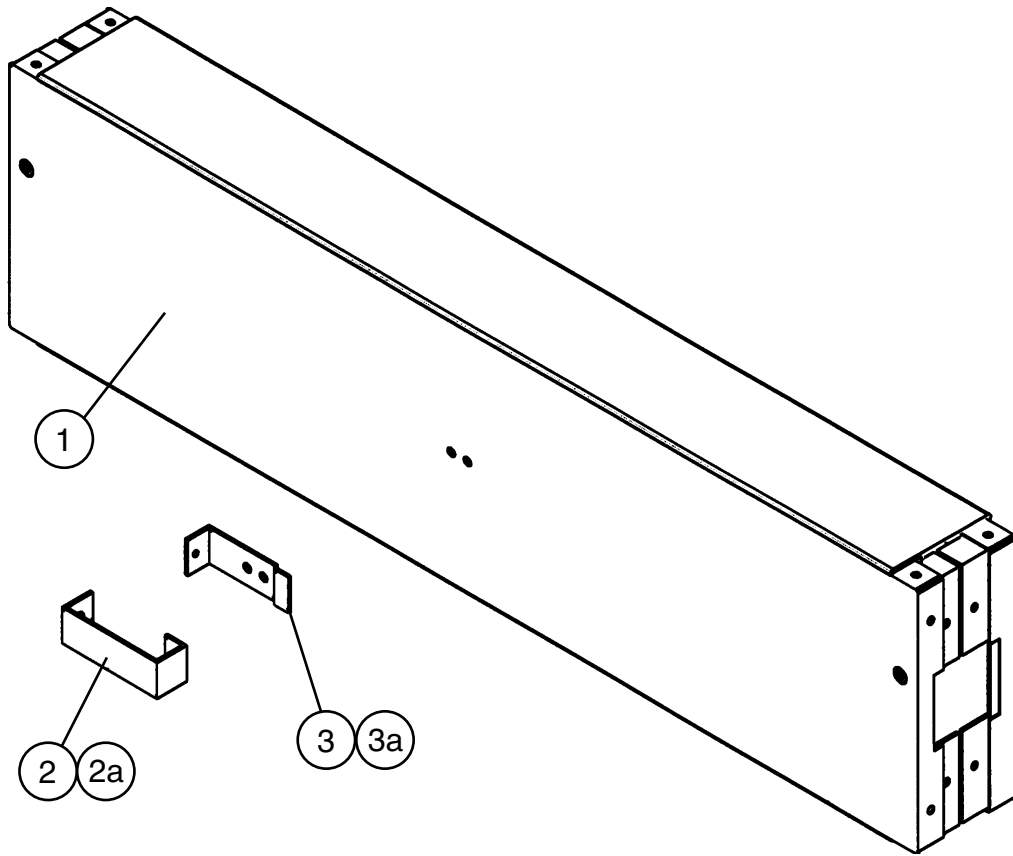

Title: S. Mullion-Horizontal Model: FH1-AAC-HD										
Index No.	Description	Material or Model Number	Part Number	Required Number						
				K-0 to Q-6						
1	Mullion – Prefoam (H)	-	2A1313G03	1						
2	Plate – Strike (Front)	SS	4A0355-01	1						
2a	Truss Head Screw	4x8, SS	7C32--0408	1						
3	Plate – Strike (Base)	SS	4A0354-01	1						
3a	T2 Screw	4x8, SS	7P32-0408	2						

T. Mullion-Vertical FH2-AAC

L-5, M-5, M-6, M-7, M-8, N-5, N-6, P-5, P-6, P-7, Q-5, Q-6

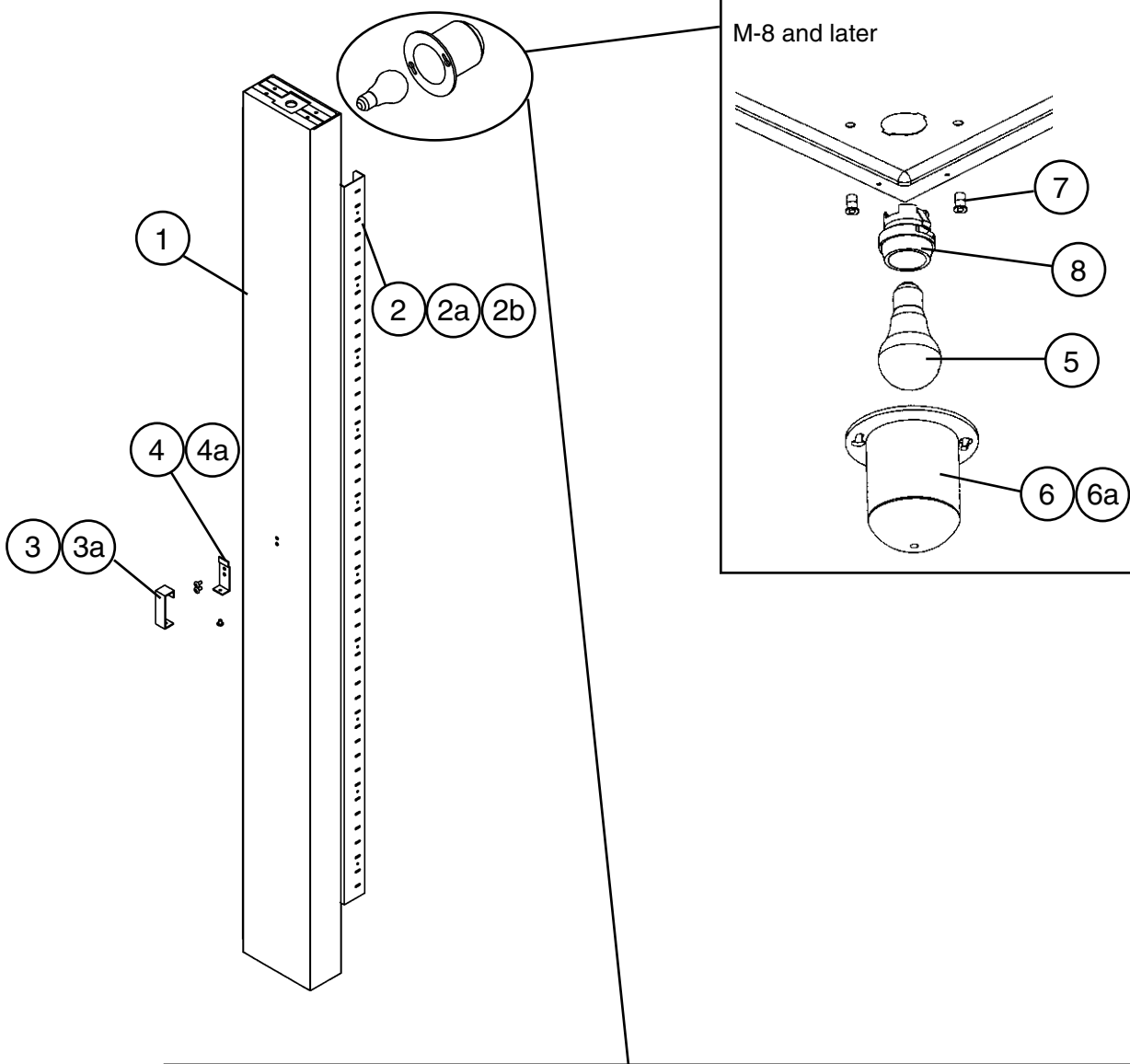

M-7 and earlier

The santoprene light socket was changed to a porcelain lampholder at M-8. This change is non-interchangeable. If the light socket is not operating on a unit with a santoprene light socket, Hoshizaki recommends replacement with HS-3554.

Note:
Parts 5, 6, and 6a are not included in HS-3554; they are shown for reference only.

Title: T. Mullion-Vertical Model: FH2-AAC										
Index No.	Description	Material or Model Number	Part Number	Required Number						
				L-5 to M-7	M-8 to P-6	P-7 to Q-6				
1	Mullion – Prefoam	-	2A1288G04	1	1	1				
2	Pilaster – Mullion	AL	2A0205-21	2	2	-				
			2A3246-21			2				
2a	Truss Head Screw	5x10, SS	7C32-0510	6	6	6				
2b	Threaded Insert		4A0407-01	6	6	6				
3	Plate – Strike (Front)	SS	4A0355-01	1	1	1				
3a	Truss Head Screw	4x8, SS	7C32-0408	1	1	1				
4	Plate – Strike (Base)	SS	4A0354-01	1	1	1				
4a	T2 Screw	4x8, SS	7P32-0408	2	2	2				
5	Bulb – Light	GE, 40A15	4A0437-01	1	-					
		-	4A2420-01		1	1				
6	Shield – Light	2778-1010-3000	4A0465-01	1	1	1				
6a	Cheese Head Screw	5x12, SS	7C52-0512	2	2	2				
6b	Washer	8, SS	7W22-0800	2	-					
7	Threaded Insert – Wide	-	4A0839-01	Non-interchangeable part change. If light socket is not operating for these codes, Hoshizaki recommends replacement with HS-3554 (below).	1	1				
8	Lampholder	-	4A2862-01		1	1				

HS-3554-Lampholder Conversion Kit					
Index No.	Description	Material or Model Number	Part Number	Required Number	
				M-7 and earlier	
HS1	Plate – Lampholder Mount	SS	4A2880-01	1	
HS1a	Cheese Head Screw	SS	7C52-0512	2	
HS2	Lampholder		4A2862-01	1	
HS2a	Terminal – Flag	DNFR18-250FIBK	8101-18FJ	2	

U. Mullion-Cross FH2-AAC-HD

K-0, L-5, M-6, N-6, P-5, P-6, P-7, P-8, Q-5, Q-6

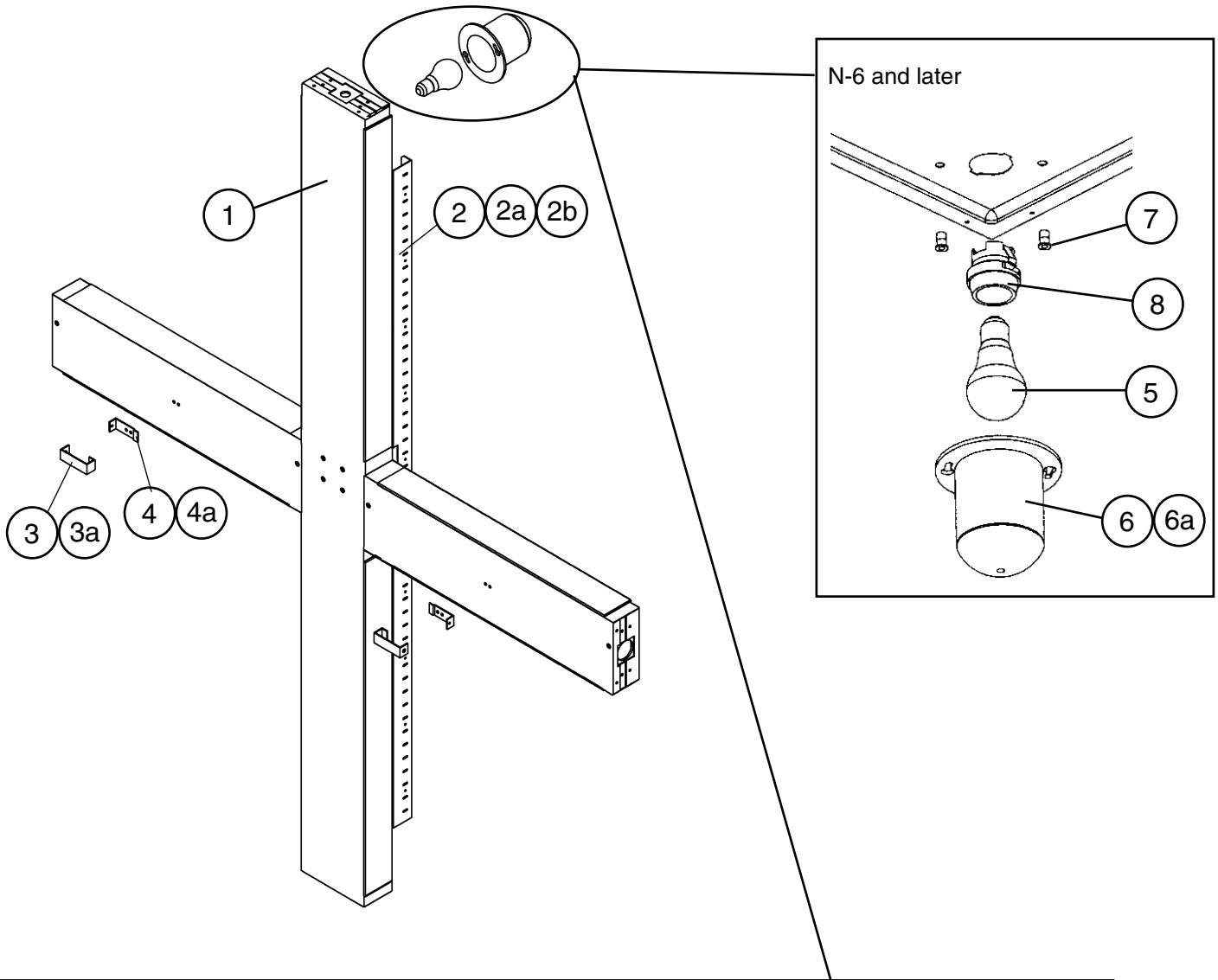

M-6 and earlier

The santoprene light socket was changed to a porcelain lampholder at N-6. This change is non-interchangeable. If the light socket is not operating on a unit with a santoprene light socket, Hoshizaki recommends replacement with HS-3554.

Note:

Parts 5, 6, and 6a are not included in HS-3554; they are shown for reference only.

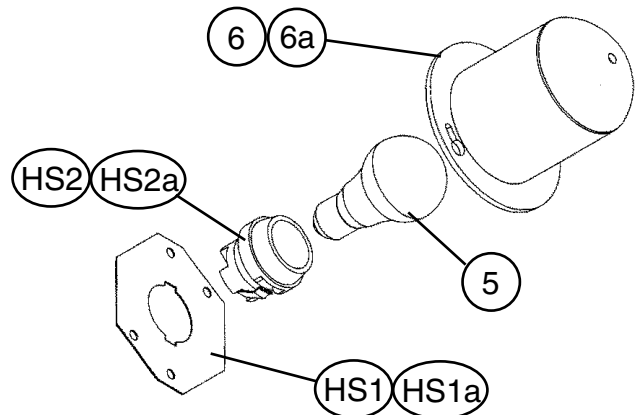

Title: U. Mullion-Cross Model: FH2-AAC-HD											
Index No.	Description	Material or Model Number	Part Number	Required Number							
				K-0 to M-6	N-6 to P-7	P-8 to Q-6					
1	Mullion – Prefoam	-	2A1288G03	1	1	1					
2	Pilaster – Mullion	AL	2A0205-21	2	2	-					
			2A3246-21			2					
2a	Truss Head Screw	5x10, SS	7C32-0510	6	6	6					
2b	Threaded Insert		4A0407-01	6	6	6					
3	Plate – Strike (Front)	SS	4A0355-01	1	1	1					
3a	Truss Head Screw	4x8, SS	7C32-0408	1	1	1					
4	Plate – Strike (Base)	SS	4A0354-01	1	1	1					
4a	T2 Screw	4x8, SS	7P32-0408	4	4	4					
5	Bulb – Light	GE, 40A15	4A0437-01	1	-						
		-	4A2420-01		1	1					
6	Shield – Light	2778-1010-3000	4A0465-01	1	1	1					
6a	Cheese Head Screw	5x12, SS	7C52-0512	2	2	2					
6b	Washer	8, SS	7W22-0800	2	-						
7	Threaded Insert Wide	-	4A0839-01	Non-interchangeable part change. If light socket is not operating for these codes, Hoshizaki recommends replacement with HS-3554 (below).	6	6					
8	Lampholder	-	4A2862-01		1	1					

HS-3554-Lampholder Conversion Kit											
Index No.	Description	Material or Model Number	Part Number	Required Number							
				M-6 and earlier							
HS1	Plate – Lampholder Mount	SS	4A2880-01	1							
HS1a	Cheese Head Screw	SS	7C52-0512	2							
HS2	Lampholder		4A2862-01	1							
HS2a	Terminal – Flag	DNFR18-250FIBK	8101-18FJ	2							

V. Label Location FH1-AAC(-HD)

K-0, L-0, L-5, M-5, M-6, M-7, N-5, N-6, P-5, P-6, P-7, P-8, Q-5, Q-6

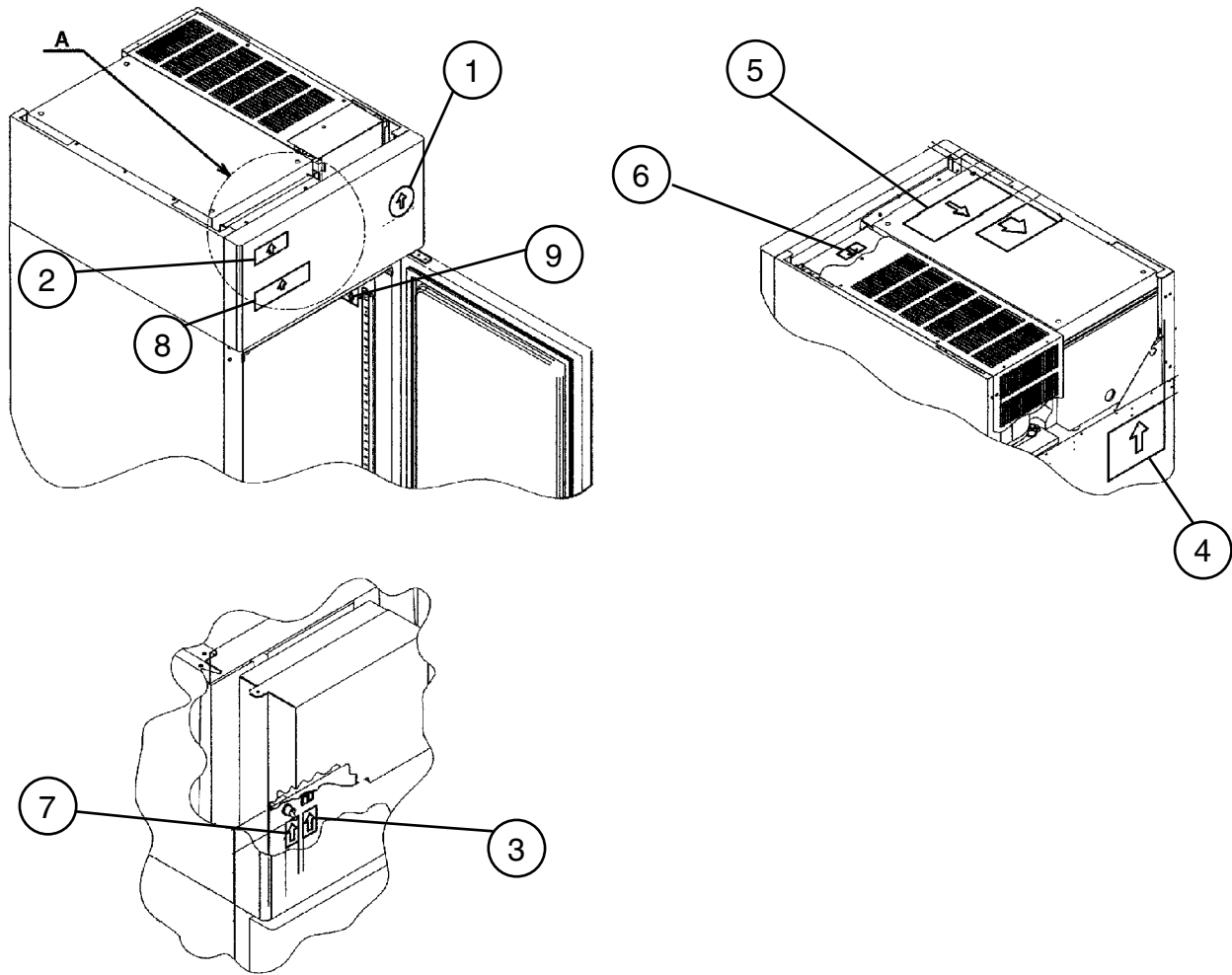

VIEW A

Title: V. Label Location Model: FH1-AAC(-HD)													
Index No.	Description	Material or Model Number	Part Number	Required Number									
				K-0 L-5	M-5 to P-5	P-6 to P-8	Q-5 to Q-6						
1	Label – Penguin – HA(L)	-	4A0526-02	1	1	1	1						
2	Emblem – Hoshizaki	-	4A0560-01	1	1	1	1						
3	Label – Door Heater Switch	PVC Film	4A1039-01	1	1	1	1						
4	Caution Label	PVC Film	4A1931-01	1	1	1	1						
5	Wiring Label	PVC Film	2A1934-01	1	1	-							
			2A2340-01			1	1						
6	Label – R404A	-	4A0960-01	1	1	1	1						
7	Label – Power	-	4A2196-01	1	1	1	1						
8	Label – Display	-	4A2286-01	1	1	1	1						
9	Cover – Nameplate	-	4A2265-01				1						

V. Label Location FH2-AAC(-HD)

K-0, L-5, M-5, M-6, M-7, M-8, N-5, N-6, P-5, P-6, P-7, P-8, Q-5, Q-6

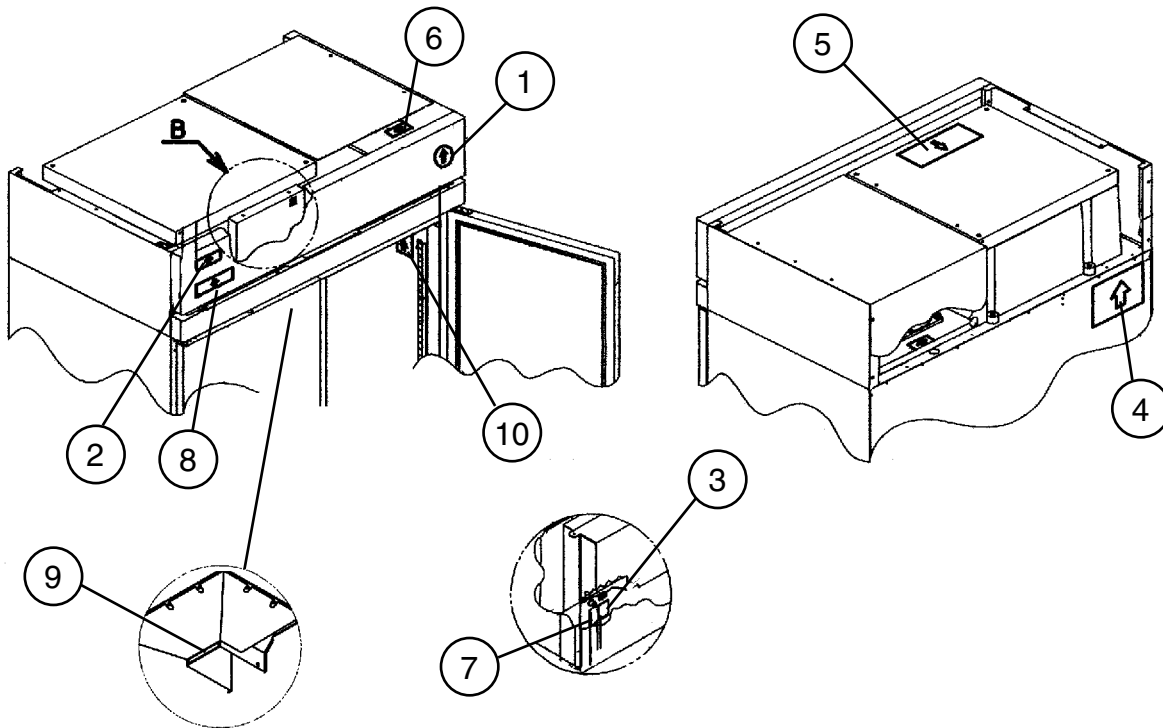

Title: V. Label Location Model: FH2-AAC(-HD)													
Index No.	Description	Material or Model Number	Part Number	Required Number									
				K-0	L-5 to P-5	P-6 to P-8	Q-5 Q-6						
1	Label – Penguin – HA(L)	-	4A0526-02	1	1	1	1						
2	Emblem – Hoshizaki	-	4A0560-01	1	1	1	1						
3	Label – Door Heater Switch	PVC Film	4A1039-01	1	1	1	1						
4	Caution Label	PVC Film	4A1931-01	1	1	1	1						
5	Wiring Label	PVC Film	2A1952-01	1	1	-							
			2A2342-01			1	1						
6	Label – R-404A	-	4A0960-01	1	1	1	1						
7	Label – Power	-	4A2196-01	1	1	1	1						
8	Label – Display	-	4A2286-01	1	1	1	1						
9	Label – Warning		4A2968-01	1	1	1	1						
10	Cover Nameplate		4A3727-01				1						

W. Literature & Packaging

FH1-AAC(-HD), FH2-AAC(-HD)

K-0, L-0, L-5, M-5, M-6, M-7, M-8, N-5, N-6, P-5, P-6, P-7, P-8, Q-5, Q-6

Title: W. Literature & Packaging Model: FH1-AAC(-HD), FH2-AAC(-HD)												
Index No.	Description	Material or Model Number	Part Number	Required Number								
				K-0 to P-7	P-8 to Q-6							
1	Instruction Manual	Paper	91A34010L	1	1							
Packaging (Available only for models currently in production)		FH1-AAC	1A0765A17	1	1							
		FH1-AAC-HD	1A0765A18	1	1							
		FH2-AAC	1A0766A13	1	1							
		FH2-AAC-HD	1A0766A14	1	1							
1	Filler – Door		4A2977-01	2	2							
2	Pad – Corner		3A2598-01	4	4							
3	Post – Corner		3A2603-01	4	4							
4	Support – Corner		3A2596-01	4	4							
5	Stop – Door		4A1873-01	1	1							
6	Stop – Door (Center)	FH1-AAC-HD FH2-AAC-HD	4A1874-01	1	1							
7	Flat Washer		7W2115800	4	4							
8	Hex Head Bolt		7B01 I5825	4	4							
9	Pallet	FH1-AAC(-HD)	3A1814-01	1	1							
		FH2-AAC(-HD)	3A1815-01	1	1							
10	Protector – Front	FH2-AAC(-HD)	3A2595-01	1	1							
11	Caster Shim		HS-3590		1							
12	Caster Kit		HS-3546		1							
13	Shelf Pack		HS-3508		1							