

NO.: U3BK-A020
ISSUED: AUG. 31, 1990
REVISED: MARCH 21, 1997



**HOSHIZAKI
ICE DISPENSING BIN**

MODEL

DB-200C

SERVICE MANUAL

FOREWORD

IMPORTANT

Only qualified service technicians should attempt to service or maintain the dispensing bin. No such service or maintenance should be undertaken until the technician has thoroughly read this Service Manual.

HOSHIZAKI provides this manual primarily to assist qualified service technicians in the service and maintenance of the dispensing bin.

Should the reader have any questions or concerns which have not been satisfactorily addressed, please call or write to the HOSHIZAKI Care Department for assistance.

HOSHIZAKI AMERICA, INC.
618 Highway 74 South
Peachtree City, GA 30269

Attn: HOSHIZAKI Care Department

Phone: 1-800-233-1940 Technical Service
(770) 487-2331
Fax: (770) 487-3360

NOTE: To expedite assistance, all correspondence/communication **MUST** include the following information:

- Model Number
- Serial Number
- Complete and detailed explanation of the problem

- Please review this manual. It should be read carefully before the dispensing bin is serviced or maintenance operations are performed. Only qualified service technicians should service and maintain the dispensing bin. This manual should be made available to the technician prior to service or maintenance.





CONTENTS

	PAGE
I. SPECIFICATIONS	1
1. NAMEPLATE RATING	1
2. DIMENSIONS/CONNECTIONS	2
3. SPECIFICATIONS	3
II. GENERAL INFORMATION	4
1. CONSTRUCTION	4
III. INSTALLATION AND OPERATING INSTRUCTIONS	5
1. CHECKS BEFORE INSTALLATION	5
2. LOCATION	5
3. SET UP	6
4. ELECTRICAL CONNECTION	8
5. DRAIN CONNECTIONS	10
6. FINAL CHECK LIST	11
7. START UP	12
8. PREPARING THE ICE DISPENSING BIN FOR LONG STORAGE.....	12
IV. MAINTENANCE AND CLEANING INSTRUCTIONS	13
1. CLEANING INSTRUCTIONS	13
[a] CLEANING PROCEDURE	13
[b] SANITIZING PROCEDURE	15
2. MAINTENANCE	15
V. TECHNICAL INFORMATION	16
1. WIRING DIAGRAMS.....	16
VI. SERVICE DIAGNOSIS	17
VII. REMOVAL AND REPLACEMENT OF COMPONENTS	19
1. GEAR MOTOR AND CHAIN	19
2. SAFETY SWITCH	19
3. SPOUT SWITCH.....	20
4. SOLENOID	20

I. SPECIFICATIONS

1. NAMEPLATE RATING

HOSHIZAKI ICE DISPENSING BIN	
MODEL NUMBER	DB-200C
SERIAL NUMBER	
AC SUPPLY VOLTAGE	115-120/60/1
AMPERES	1.4 AMPS
MAXIMUM FUSE SIZE	15 AMPS
MINIMUM CIRCUIT AMPACITY	15 AMPS

HOSHIZAKI AMERICA, INC. Peachtree City, GA	
	LISTED ACCESSORY OF ICE MAKER 946Z
	
COMPONENT 	

See NAMEPLATE for electrical specifications. The nameplate is located on the upper part of the right side panel.

- We reserve the right to make changes in specifications and design without prior notice.

2. DIMENSIONS/CONNECTIONS

[a] with KM-280M_ or KM-500M_

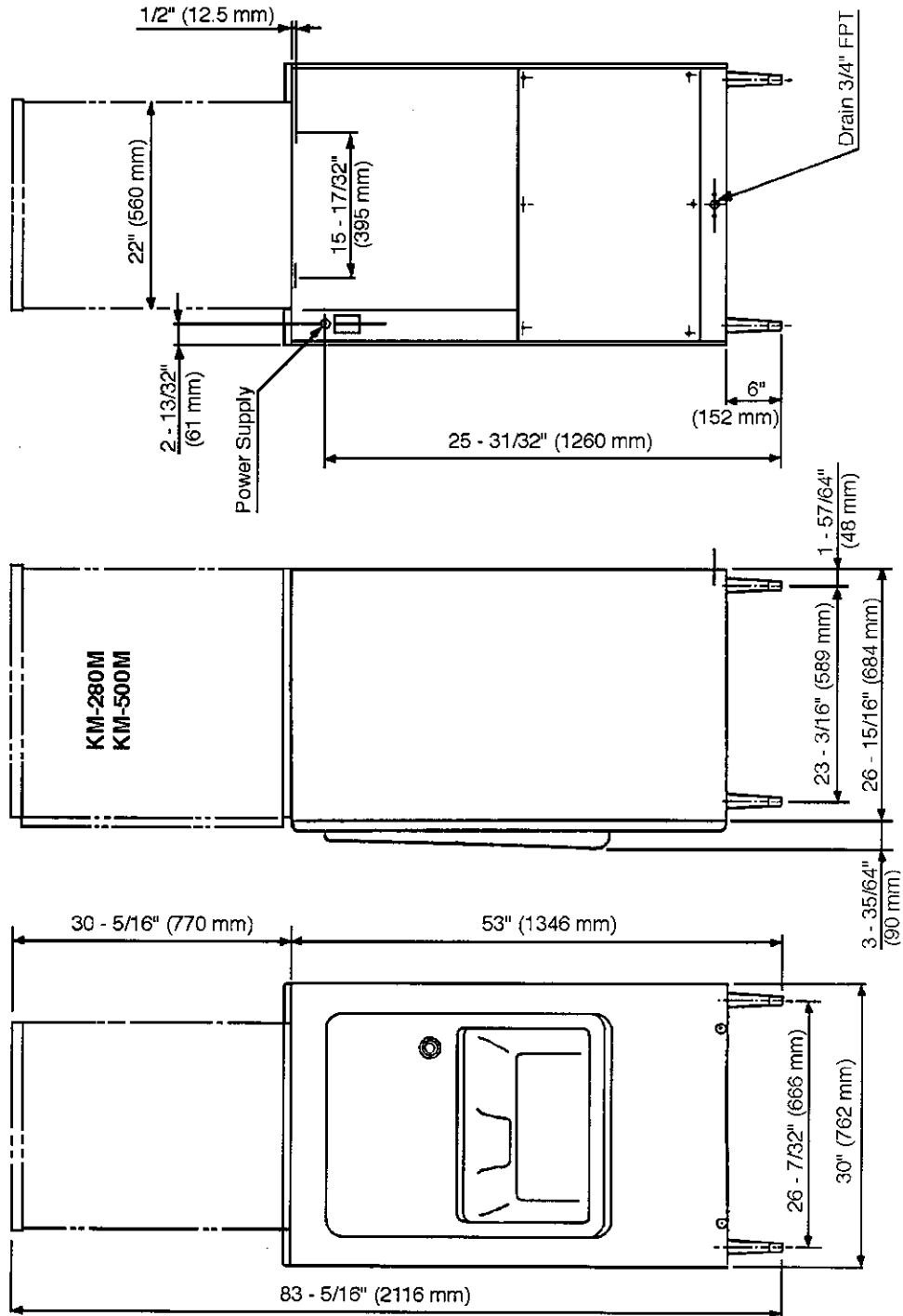

[b] with KM-630M

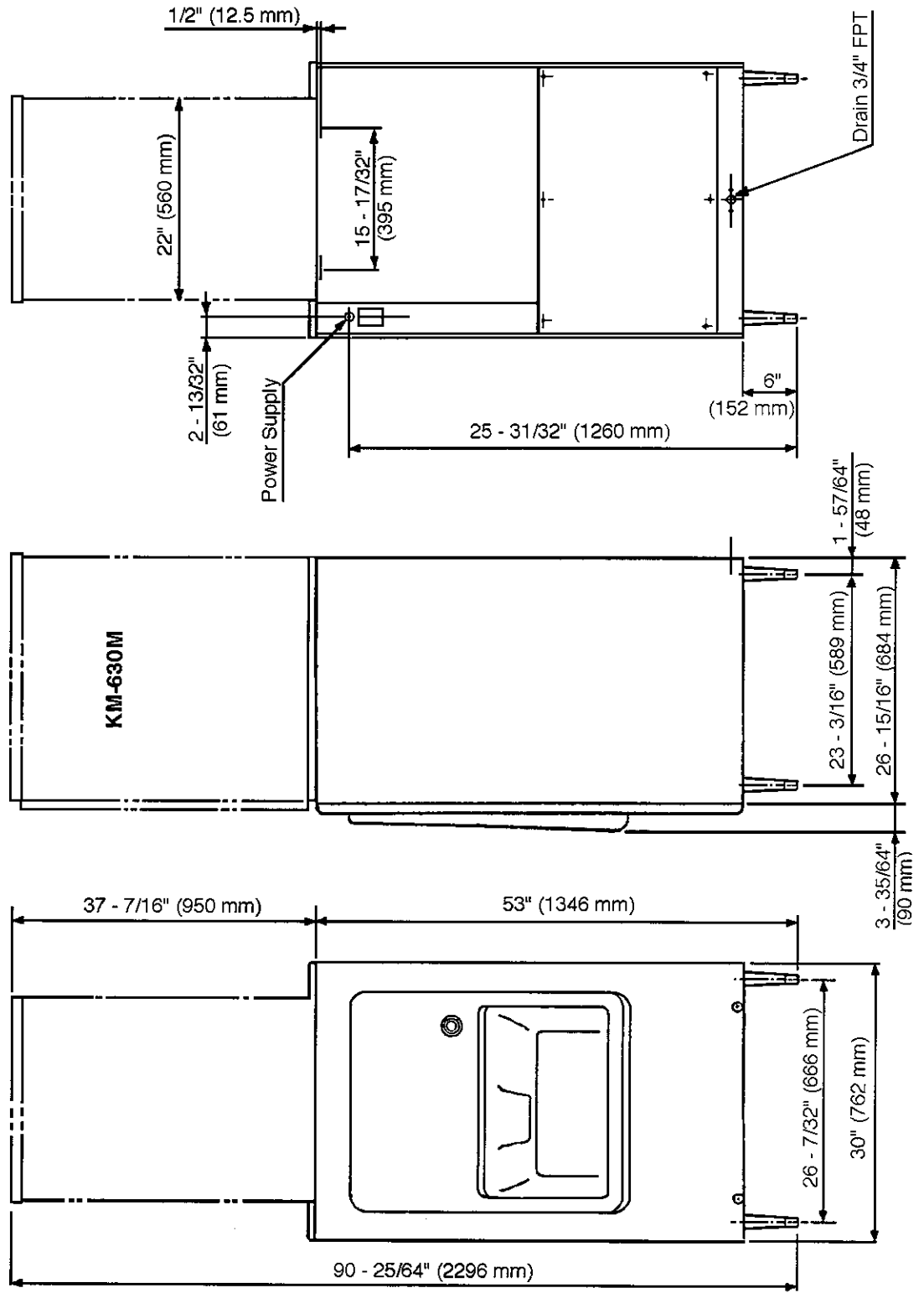

[c] with KML-200M_ or KML-400M_

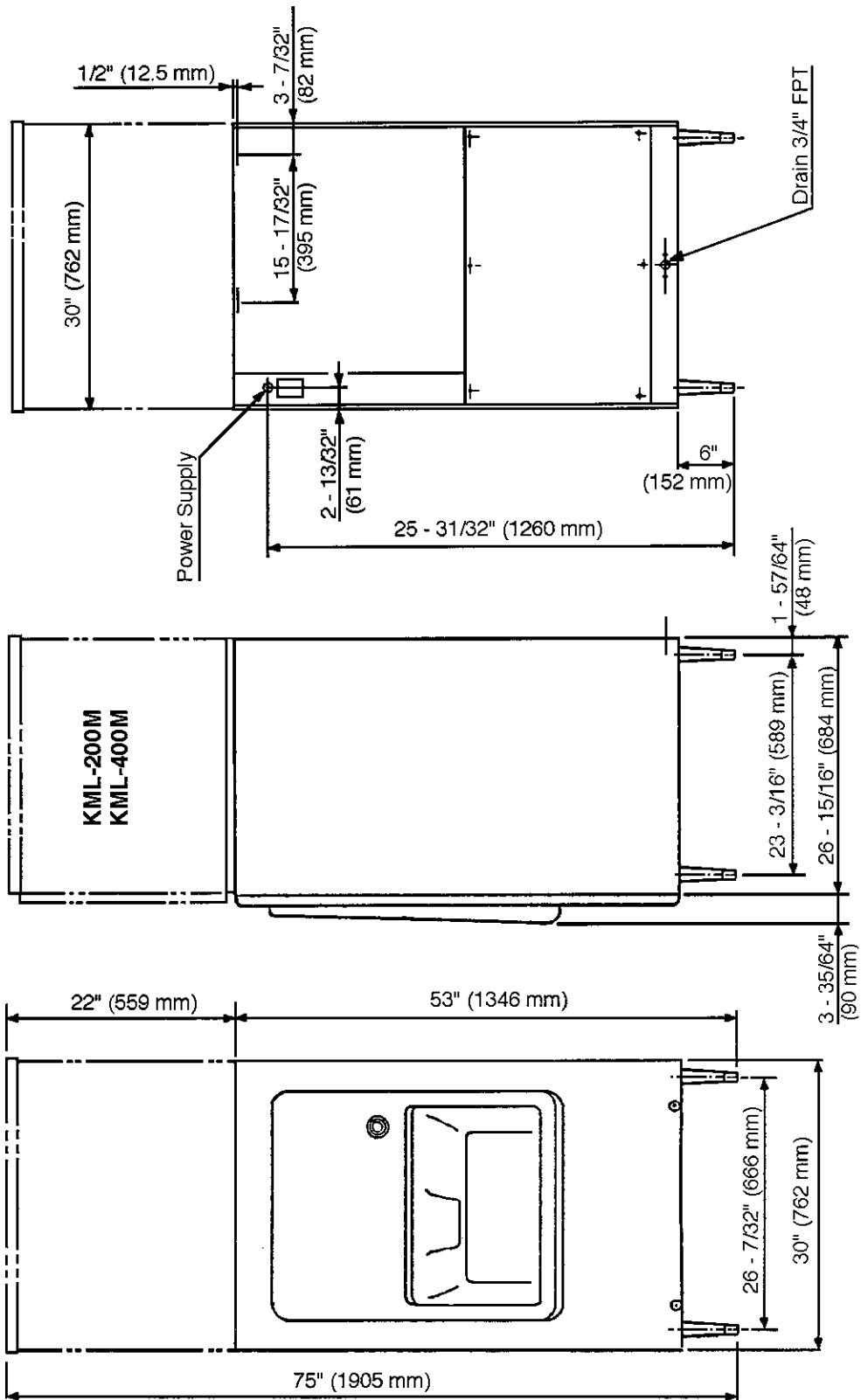

3. SPECIFICATIONS

AC SUPPLY VOLTAGE	115-120/60/1	
AMPERAGE	1.4 A	
MINIMUM CIRCUIT AMPACITY	15A	
MAXIMUM FUSE SIZE	15A	
APPROXIMATE ELECTRIC CONSUMPTION	110 W	
APPROXIMATE STORAGE CAPACITY	130 lbs. (60 kg.)	
SPOUTING SPEED	20 lbs./min. (9 kg./min.)	
EXTERIOR DIMENSIONS (W x D x H)	22" x 30.5" x 53" (560 x 774 x 1346 mm.) Including 6" Leg	
INTERIOR DIMENSIONS (W x D x H)	15.3" x 22.4" x 22.5" (389 x 569.5 x 571 mm.)	
EXTERIOR FINISH	P.V.C. coated Galvanized Steel, Galvanized Steel (Rear)	
INTERIOR FINISH	Polyethylene 1 pc. Mold	
INSULATION	Polyurethane Foam	
WEIGHT	Net 178.4 lbs. (81 kg.), Shipping 220 lbs. (100 kg.)	
CONNECTIONS - ELECTRIC	Permanent Connection	
- WATER SUPPLY	N/A	
- DRAIN	Outlet	3/4" FPT
GEAR MOTOR	60 W	
AGITATOR	Stainless Steel Round Bar 14.5" diameter	
GEAR MOTOR PROTECTION	Thermal Protector (Internal)	
SAFETY PROTECTION	Door Switch (Serial # A00966-C01915 only) Safety Switch for Ice Spout	
ACCESSORIES - SUPPLIED	6" Leg, 4 pcs.	
OPERATION CONDITIONS	VOLTAGE RANGE	104 - 132 V
	AMBIENT TEMP.	45 - 100° F

* We reserve the right to make changes in specifications and design without prior notice.

II. GENERAL INFORMATION

1. CONSTRUCTION

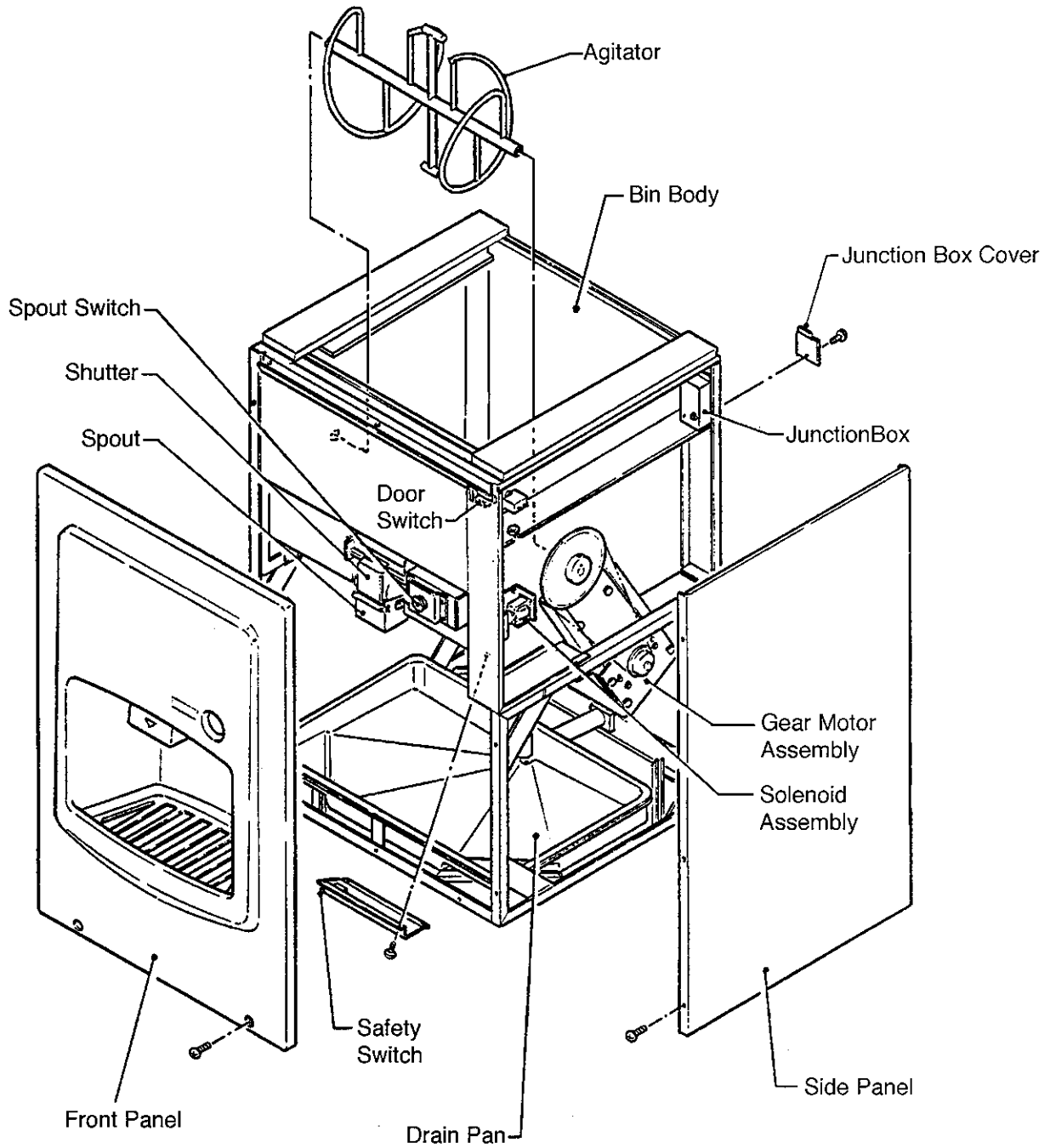

III. INSTALLATION AND OPERATING INSTRUCTIONS

1. CHECKS BEFORE INSTALLATION

IMPORTANT

1. This ice dispensing bin is designed and intended to be used in combination with a HOSHIZAKI Modular Crescent Ice Cuber, Models KM-250M, KM-280M, KM-500M, KM-630M, and KML-200M and KML-400M. Using this ice dispensing bin in combination with any cuber or flaker other than a Hoshizaki Modular Crescent Ice Cuber cannot be recommended.
2. Remove shipping carton, tape(s) and packing to prevent damage to the ice dispensing bin.

- 1) Remove the Front Panel to prevent damage before installing.
- 2) Remove the package containing the accessories.
- 3) Remove the protective plastic film from the Side Panels. If the ice dispensing bin has been exposed to the sunlight or to direct heat, it should be allowed to cool before removing the protective film.
- 4) See the Nameplate, located on the upper part of the Right Side Panel. Check that the voltage supplied corresponds with the voltage specified on the Nameplate.

2. LOCATION

IMPORTANT

This ice dispensing bin is not intended for outdoor use. Normal operating ambient temperature should be within +45°F to +100°F. Operation of the ice dispensing bin for extended periods, outside of these normal temperature ranges may cause unsatisfactory results.

For best operating results:

- Ice dispensing bin should not be located next to ovens, grills or other high heat producing equipment.
- Location should provide a firm and level foundation for the equipment.
- Always avoid a site where dripping is not allowed.
- Allow 6" clearance at rear and sides for ease of maintenance and/or service should they be required. More space is needed especially on the left side of the dispensing bin to service the drive system.

CAUTION

The icemaker will not work in sub-freezing temperatures. To prevent damage to the water supply line, always drain the icemaker when air temperature is 32°F or below.

3. SET UP - See Fig. 1

IMPORTANT

For optimum performance it is important that the icemaker/ice dispensing bin is leveled in both left-to-right and front-to-rear directions. If it is not level, the result could be the production of smaller or irregular shaped cubes, or overflow into the ice dispensing bin. See the "LOCATION" instructions on the icemaker.

- 1) Unpack the ice dispensing bin, and remove all shipping carton, tape(s) and packing before operating the unit. Attach four adjustable legs (adjustable within max. 6-13/32" to min. 6" to the bottom of the ice dispensing bin. Remove the front panel to prevent damage and be careful not to damage the other panels when installing the ice dispensing bin.
Remove the screws, and pull up and toward you to remove the Front Panel.
- 2) Position the ice dispensing bin in a selected permanent site.
Clean and wipe the interior with a clean cloth.
- 3) Unpack the icemaker, and remove all shipping tape(s) and packing.
- 4) See the "SET UP" instructions on the icemaker when installing the icemaker.
- 5) Attach the icemaker to the top of the dispensing bin, and secure the icemaker by using two Universal Braces and four Hexagon Head bolts (KM accessory).
- 6) Level the icemaker/ice dispensing bin in both the left-to-right and front-to-rear directions.
- 7) Place exterior panels in position on both the icemaker and the ice dispensing bin. See the "SET UP" instructions on the icemaker.

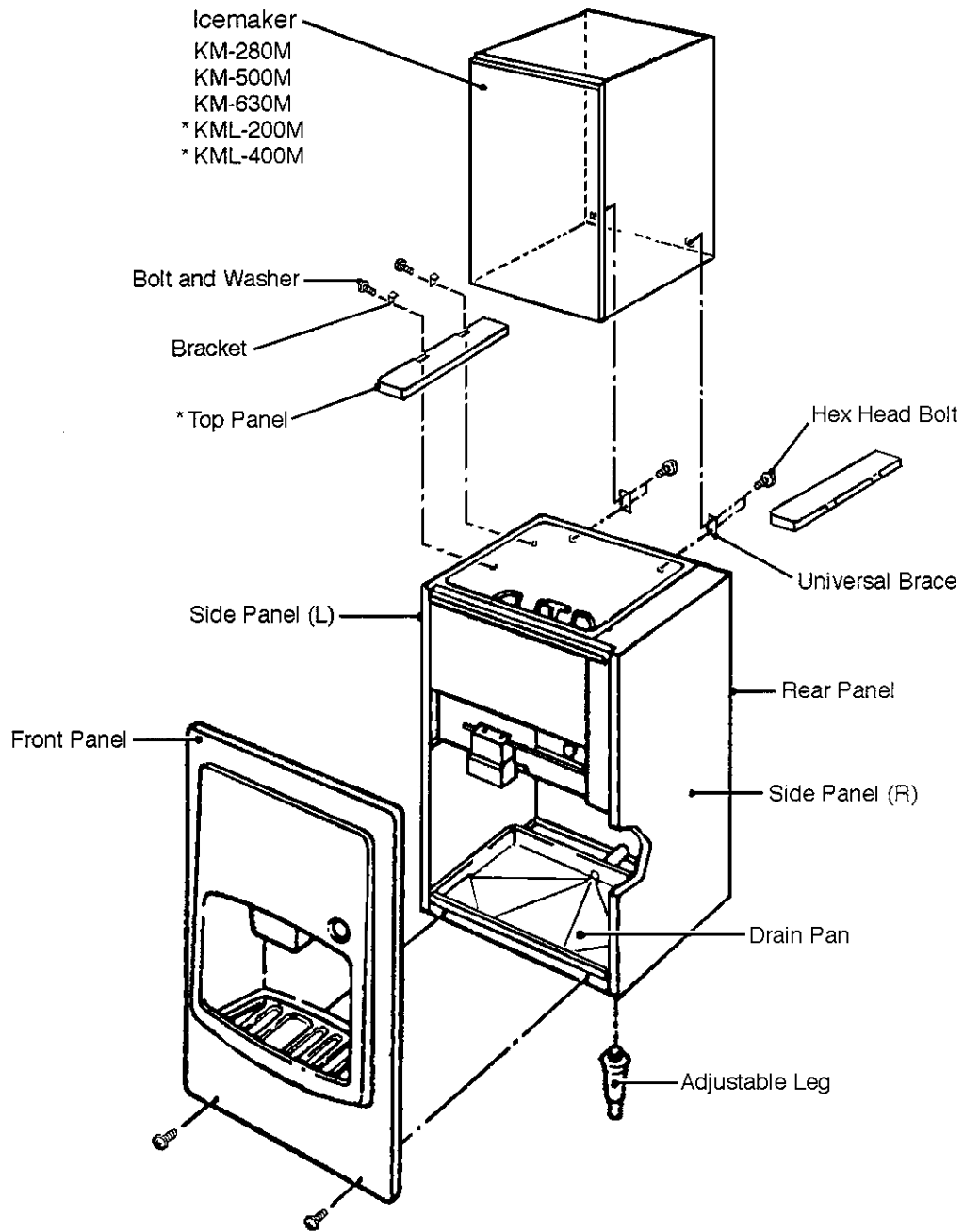

*Note: With KML models, Top Panels are not necessary.

Fig. 1

4. ELECTRICAL CONNECTION

WARNING

1. Electrical connection must be made in accordance with the instructions on a "WARNING" tag, provided with the pig tail leads in the Junction Box.
2. To prevent possible electrical shock to individuals or extensive damage to the equipment, install a proper ground wire to the ice dispensing bin that meets local code requirements.

- The white lead must be connected to the neutral conductor of the power source. Miswiring results in severe damage to the ice dispensing bin. See Fig. 2.
- The ice dispensing must have a separate power supply or receptacle of proper capacity. See the Nameplate.
- Check that the ice dispensing switch and the safety switch are operating correctly. See Fig. 3.

Ice Dispensing Switch

Push the button, and the unit should operate. You can hear an operating sound.

Safety Switch

Continue pushing the button, and move the spout toward you. Then the safety switch should operate to stop the unit.

Door Switch
(Serial # A00966–C01915)

The ice dispensing bin should not operate with the front panel removed when you push the button.

- Usually an electrical permit and services of a licensed electrician are required.

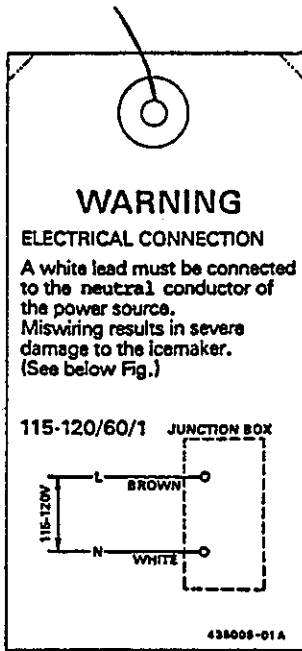

Fig. 2

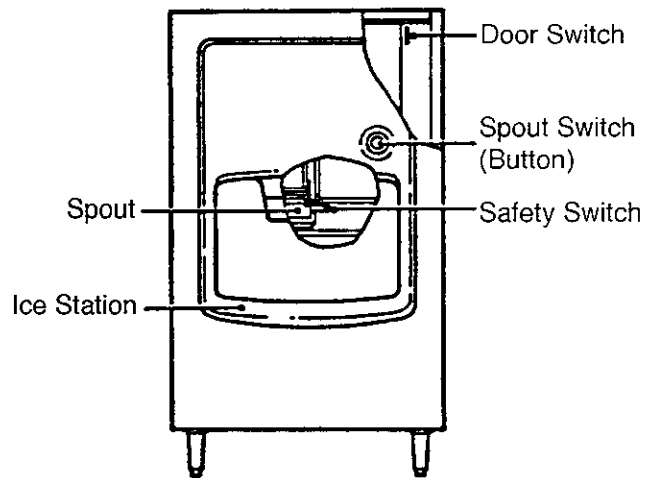

Fig. 3

5. DRAIN CONNECTIONS - See Fig. 4

- A drain outlet, 3/4" female thread, is located at the rear of the ice dispensing bin.
- The drain must have 1/4" fall per foot on horizontal runs to provide a good flow.
- The ice dispensing bin drain connection must be made separately from the icemaker drains. See the "WATER SUPPLY AND DRAIN CONNECTIONS" instructions on the icemaker.
- A plumbing permit and services of a licensed plumber may be required in some areas.

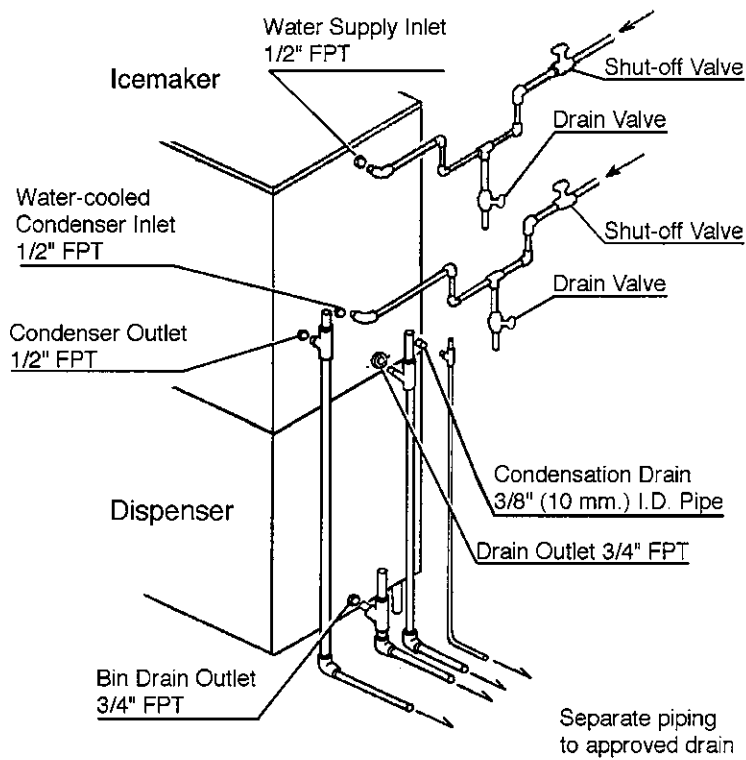
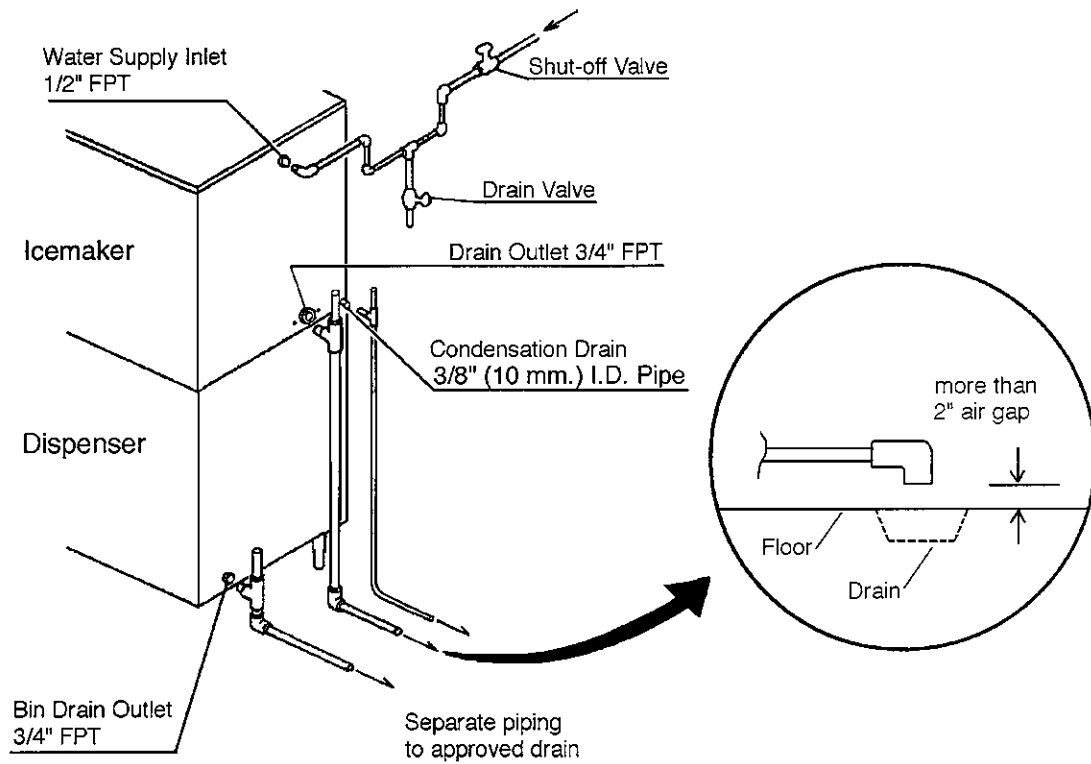

Fig. 4

6. FINAL CHECK LIST

- 1) Is the icemaker/ice dispensing bin level?
- 2) Is the icemaker/ice dispensing bin in a site where the ambient temperature is within +45°F to +100°F all year around?
- 3) Is there at least 6" clearance around the icemaker/ice dispensing bin for easy maintenance and service, and for good ventilation?
- 4) Have all shipping carton, tape(s) and packing been removed from the icemaker?
- 5) Have all electrical and piping connections been made?
- 6) Has the power supply voltage been checked or tested against the nameplate rating?
Has a proper ground been installed in the icemaker/ice dispensing bin?
- 7) Has the ice dispensing bin been cleaned and wiped with a clean cloth?
- 8) Has the end user been given the instruction manual, and instructed on how to operate the icemaker/ice dispensing bin and the importance of the recommended periodic maintenance?
- 9) Has the end user been given the name and telephone number of the contracted service representative?
- 10) Has the warranty tag been filled out and forwarded to the factory for warranty registration?

7. START UP

- 1) Start up the icemaker. See the "START UP" instructions on the icemaker.
- 2) Allow at least three cycles of ice production, and then place a proper container in the ice station.
- 3) Push the ice dispensing switch, to dispense ice cubes.

8. PREPARING THE ICE DISPENSING BIN FOR LONG STORAGE

IMPORTANT

Drain the icemaker and remove all ice from the ice dispensing bin, when shutting off the icemaker/ice dispensing bin for storage. The ice dispensing bin should be cleaned and wiped dry for sanitizing.

- 1) Shut off the icemaker. See the "PREPARING THE ICEMAKER FOR LONG STORAGE" instructions on the icemaker.
- 2) Turn off the power supply switches for both the icemaker and the ice dispensing bin after removing all ice.
- 3) The ice dispensing bin should be cleaned and wiped dry.

IV. MAINTENANCE AND CLEANING INSTRUCTIONS

1. CLEANING INSTRUCTIONS

WARNING

1. HOSHIZAKI recommends cleaning this unit at least once a year. (See the “CLEANING INSTRUCTIONS” on the icemaker.) More frequent cleaning, however, may be required in some existing water conditions.
2. To prevent injury to individuals and damage to the icemaker/ice dispensing bin, do not use ammonia type cleaners.
3. Always wear liquid-proof gloves for safe handling of the cleaning and sanitizing solution. This will prevent irritation in case the solution contacts the skin.

[a] CLEANING PROCEDURE

- 1) Clean and sanitize the ice dispensing bin/icemaker (See the cleaning instructions on the icemaker.) as conditions require.
- 2) Remove all ice from the bin.
- 3) Disconnect electrical power to the ice dispensing bin/icemaker.
- 4) Remove the Front Panel to allow access to the Chute Assembly for cleaning.
- 5) Remove or reposition the icemaker to allow access to the inside. Be sure that icemaker is secured and cannot fall.
- 6) Scrub the Shutter Assembly and Spout of the bin, Spout of the front panel and chute using a nylon scouring pad, brushes and cleaning solution, such as 5 oz. Hoshizaki “Scale Away” or “Lime-A-Way” (Economic Laboratories Inc.), in one gallon of water.
- 7) Scrub the Shutter Assembly and Spout—after removing them—using the cleaning solution of item 6. See Fig. 5.

- a) Remove the Snap Pin fitted to the Shutter Shaft and shift the Shaft to the left. Then the Shutter Assembly can be removed from the bin.
 - b) Pull out on the sides of the Hook to release the Spout. Lift the Spout up and out from the bin.
 - c) Remove the Thumbscrews holding the Hook and remove the Hook.
- 8) Rinse all parts thoroughly with clean water.

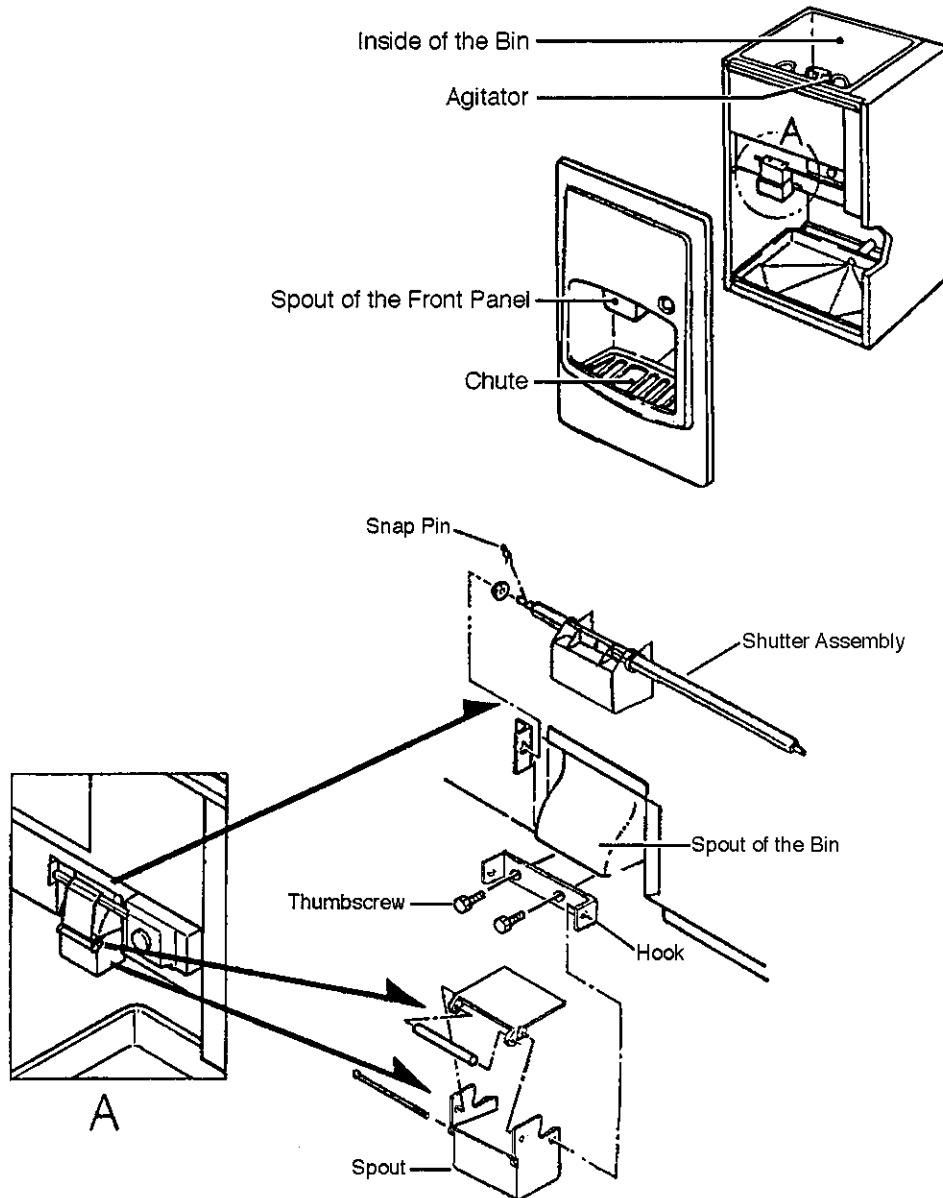

Fig. 5

[b] SANITIZING PROCEDURE - Following Cleaning Procedure

- 1) Wash all parts in steps 6) and 7) using the following sanitizing solution: 1/2 fl. oz. of IMS-II Sanitizer or a 5.25% sodium hypochlorite solution diluted in 1 gallon of water.

Note: IMS-II Sanitizer, Part #SA0004, is available through your Hoshizaki Dealer.

- 2) Rinse all parts thoroughly with clean water.
- 3) Reassemble in the reverse order of the removal procedure.
- 4) Turn on the icemaker/ice dispensing bin.
- 5) Check for proper operation. (See the "ELECTRICAL CONNECTION" instructions.)

2. MAINTENANCE

- 1) Exterior Panels

To prevent corrosion, wipe occasionally with a clean, soft cloth. Use a damp cloth containing a neutral cleaner to wipe off oil or dirt build up.

V. TECHNICAL INFORMATION

1. WIRING DIAGRAMS

(with Panasonic Gear Motor)

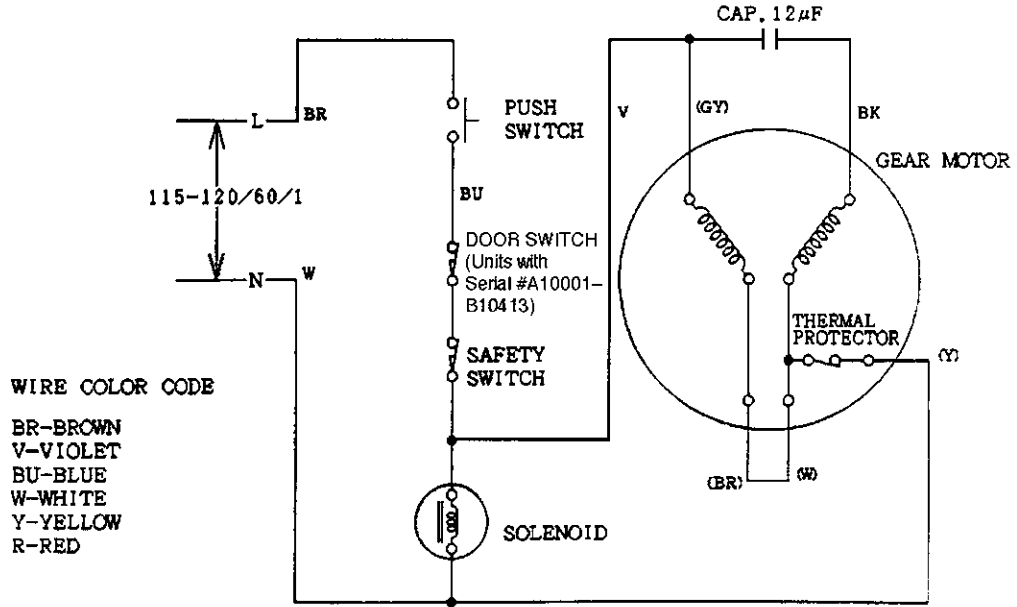

(with Von Weise Gear Motor)

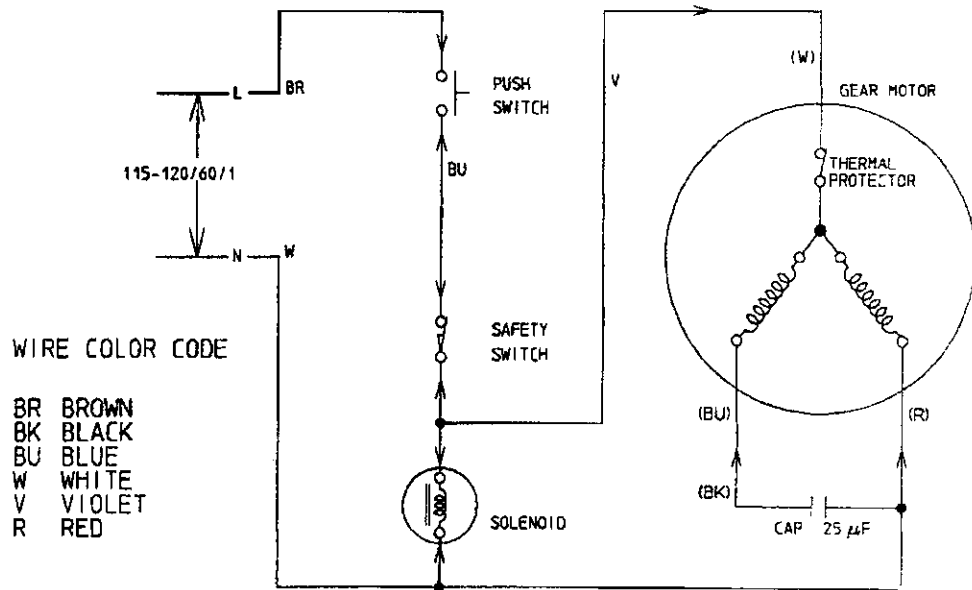

VI. SERVICE DIAGNOSIS

PROBLEM	POSSIBLE CAUSE		REMEDY
[1] No ice dispensed.	a) Power Source	1. OFF position.	1. Move to ON position
		2. Loose connection.	2. Tighten
		3. Bad contacts.	3. Check for continuity and replace.
		4. Voltage too high.	4. Check and get recommended voltage.
	b) Fuse (Inside Fuse Disconnected, if any)	1. Blown out.	1. Check for short circuit and replace
	c) Spout Switch	1. Bad contacts.	2. Check for continuity and replace.
		2. Loose connection.	2. Tighten
	d) Door Switch	1. Front panel is not in position.	1. Place in position.
		2. Actuating Plate does not push Door Switch.	2. Check for continuity and adjust.
		3. Bad contacts.	3. Check for continuity and replace.
		4. Loose connection.	4. Tighten.
	e) Safety Switch	1. Spout is not in position.	1. Check for continuity and place in position.
		2. Bad contacts.	2. Check for continuity and replace.
		3. Loose connection.	3. Tighten.
	f) Gear Motor	1. Thermal protector is tripped.	1. Check for continuity and place in position.
		2. Gear Motor winding opened.	2. Replace.
		3. Bearing worn out.	3. Replace.
		4. Wiring to Gear Motor.	4. Check for loose connection or open circuit, and replace wiring as needed.
		5. Defective capacitor.	5. Replace.
		6. Agitator rotates in reverse direction.	6. Check leads and reverse the connections.
	g) Solenoid	1. Solenoid winding open.	1. Replace.
		2. Wiring to Solenoid.	2. Check for loose connection or open circuit and replace wiring as needed.
		3. Overload due to loosening screws.	3. After tightening, apply Thread Sealant to the parts.
	h) Mechanism	1. Chain out of position or loose.	1. Place in position or tighten.
2. Corrosion.		2. Apply oil.	
3. Key of sprocket is not in position.		3. Place in position.	
4. Bad alignment of Sprocket.		4. Readjust.	
5. Foreign matter interrupting agitator.		5. Remove foreign matter.	

PROBLEM	POSSIBLE CAUSE		REMEDY
	i) Ice Storage	1. No ice or little ice in storage bin. 2. Ice bridge or block formed.	1. Make ice. 2. Break with a poker.
[2] Abnormal noise	a) Gear Motor or Gear Head	1. Bearing worn out. 2. Grease leaks.	1. Replace. 2. Supply grease, and replace O-ring.
	b) Mechanism	1. Bad setting.	1. Apply oil and readjust.
		2. Bad alignment of sprocket.	2. Readjust.
		3. Foreign matter interrupting agitator.	3. Remove foreign matter.
	c) Solenoid	1. Overload due to loosening screws.	1. After tightening, apply Thread Sealant on the parts.
2. Foreign matter on plunger.		2. Clean.	
[3] Ice in storage bin often melts.	a) Bin Drain	1. Foreign matter blocking bin drain.	1. Remove foreign matter.

VII. REMOVAL AND REPLACEMENT OF COMPONENTS

1. GEAR MOTOR AND CHAIN

- 1) Turn off the power supply.
- 2) Remove the Front Panel and left Side Panel.
- 3) Loosen the four bolts holding the Gear Motor Bracket (B) and the adjusting bolt.
- 4) Remove the Chain.
- 5) Loosen the Socket Set Screw and remove the Sprocket by using a Gear Puller.
- 6) Install a new Gear Motor.

NOTE: 1. When removing the Gear Motor and Gear Head, take care to keep the grease (Panasonic Gear Motor only).

2. When assembling the Gear Motor and the Gear Head, check if the O-ring is secured to the Gear Head and Not damaged. A scratch can cause a grease leak. Locking torque is 26 in. lb.

- 7) Assemble the removed parts in the reverse order of the above procedure.

NOTE: 1. When weight (2.2 lb.) is applied to the chain at the center, the displacement must be 0.31–0.51".

2. The lubricant (Class SAE 20) must be put on the chain using a cloth.

- 8) Turn on the power supply.

2. SAFETY SWITCH

- 1) Turn off the power supply.
- 2) Remove the Front Panel.
- 3) Remove the Safety Switch Cover.
- 4) Disconnect the Connectors from the Safety Switch leads.
- 5) Install a new Safety Switch.
- 6) Assemble the removed parts in the reverse order of the above procedure.
- 7) Turn on the power supply.

3. SPOUT SWITCH

- 1) Turn off the power supply.
- 2) Remove the Front Panel.
- 3) Remove the Spout Switch Assembly and Barrier (A).
- 4) Disconnect the connectors from the Spout Switch leads.
- 5) Install a new Spout Switch.
- 6) Assemble the removed parts in the reverse order of the above procedure.
- 7) Turn on the power supply.

4. SOLENOID

- 1) Turn off the power supply.
- 2) Remove the Front Panel and the Left Side Panel.
- 3) Disconnect the connectors from the Solenoid leads, and remove the Solenoid Assembly.
- 4) Remove the Solenoid, and install a new Solenoid. Securing torque should be 13–17.3 in. lb.
- 5) Assemble the removed parts in the reverse order of the above procedure.
- 6) Turn on the power supply.

