

NO. 24CG-2093

ISSUED: FEB. 19, 1999

REVISED: APR. 11, 2002

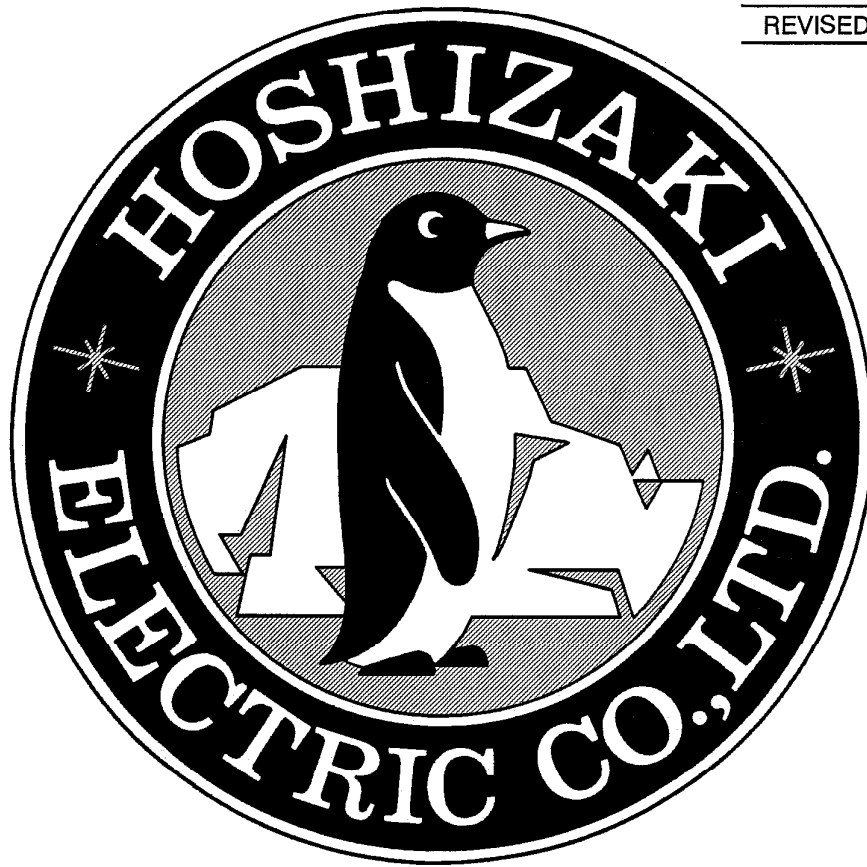

**HOSHIZAKI
CUBELET ICE MAKER**

MODEL DCM-120FE

PARTS LIST
(HE)

H-1 JUL. 1998
H-2 SEP. 1998
J-0 DEC. 1998
J-1 JAN. 1999
J-2 MAR. 1999
J-3 JUL. 1999
J-4 JUL. 1999
J-5 DEC. 1999
K-1 JAN. 2000
A-0 FEB. 2001
A-1 MAY 2001
B-1 DEC. 2001
B-2 JAN. 2002
B-3 MAY 2002

MATERIAL ABBREVIATIONS

PLASTIC

ABS	=	Acrylonitrile-butadien-styrene
AC	=	Polyacetal
EVA	=	Ethylene vinyl acetate
PA	=	Polyamide = Nylon
PC	=	Polycarbonate
PE	=	Polyethylene
PES	=	Polyester
PETP	=	Polyethylene terephthalate = Tetlon
PF	=	Phenol-formaldehyde
PP	=	Polypropyleneoride
PS	=	Polystyrene
PTFE	=	Polytetrafluoroethylene = Teflon
PUR	=	Polyurethane
PVC	=	Polyvinyl chloride

RUBBER

EPDM	=	EP rubber
NBR	=	Nitrile butadiene rubber
NR	=	Natural rubber
SI.R	=	Silicone rubber
SY.R	=	Synthetic rubber

STEEL

G.S	=	Galvanized steel
S.S	=	Stainless steel

AUXILIARY CODE

- Ex.1
- K-0
- Parts are the same as in the preceding year.
- "K" is the tenth in alphabetical order with "I" skipped.
So, "K" indicates "2000".
- Ex.2
- A-1
- "A" is the first in alphabetical order.
So, "A" indicates "2001".
- Ex.3
- A-2
- Each time a part is changed in a year, this number advances.

(Note)

-- Part deleted.
X = Part deleted and replaced by "O" part.
O = New part for "X" in the same auxiliary code.

FASTENER ABBREVIATION LIST

ST	Phillips Truss Head Machine Screw
SP	Phillips Pan Head Machine Screw
SF	Phillips Flat Head Machine Screw
SS	Phillips Pan Head Machine Screw with Split Lock Washer
SW	Phillips Pan Head Machine Screw with Split Lock Washer and Flat Washer
T1	Phillips Truss Head Tapping Screw (Correspond to Type A)
T2	Phillips Truss Head Tapping Screw (Correspond to Type B)
T3	Phillips Truss Head Tapping Screw (Correspond to Type C)
FT	Phillips Truss Head Tapping Screw (Special)
BH	Hexagon Head Bolt
BC	Socket Head Cap Screw
BS	Hexagon Bolt with Split Washer
BW	Hexagon Bolt with Split Washer and Flat Washer
BF	Hexagon Flange Bolt
BR	Cross-Recessed Hexagon Head Bolt
BRW	Cross-Recessed Hexagon Head Bolt with Split Lock Washer and Flat Washer
WL	Split Lock Washer
WT	External Tooth Washer
WF	Flat Washer
WS	Spring Washer
NH	Hexagon Nut
NF	Hexagon Flange Nut
NC	Hexagon Cap Nut
NS	Square Nut
NW	Wing Nut

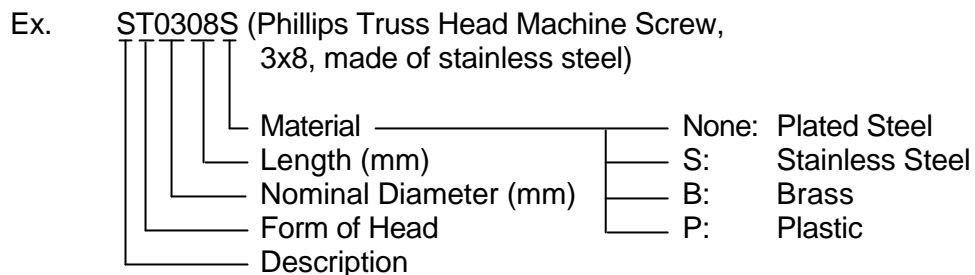

(Note) Second character is numerical except the list.

Ex. S1, S2, B3 etc.

And abbreviations and names are shown under the illustration.

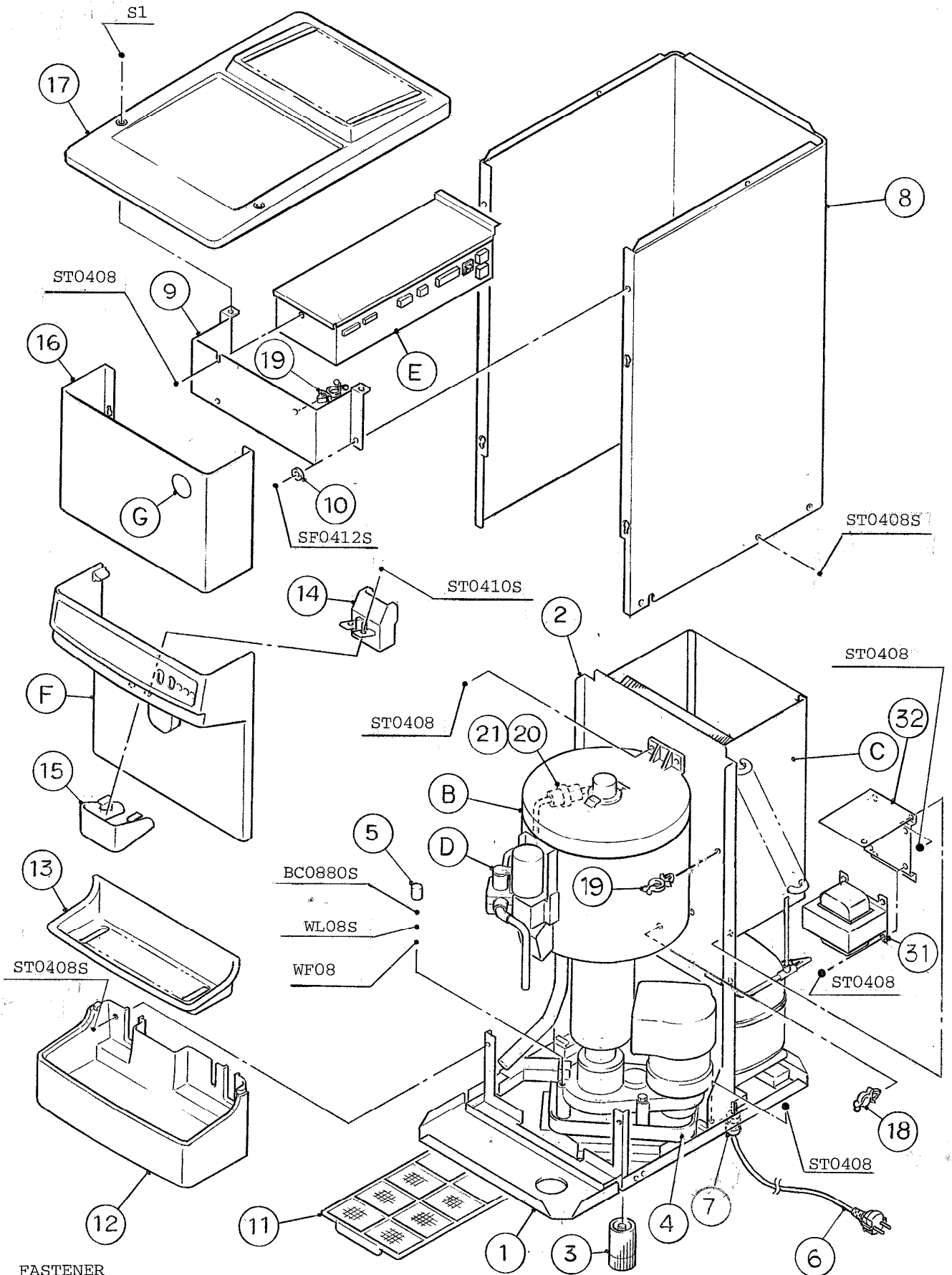

FASTENER
S1 - TRUSS HEAD MACHINE SCREW
WITH PP WASHER, M4x8

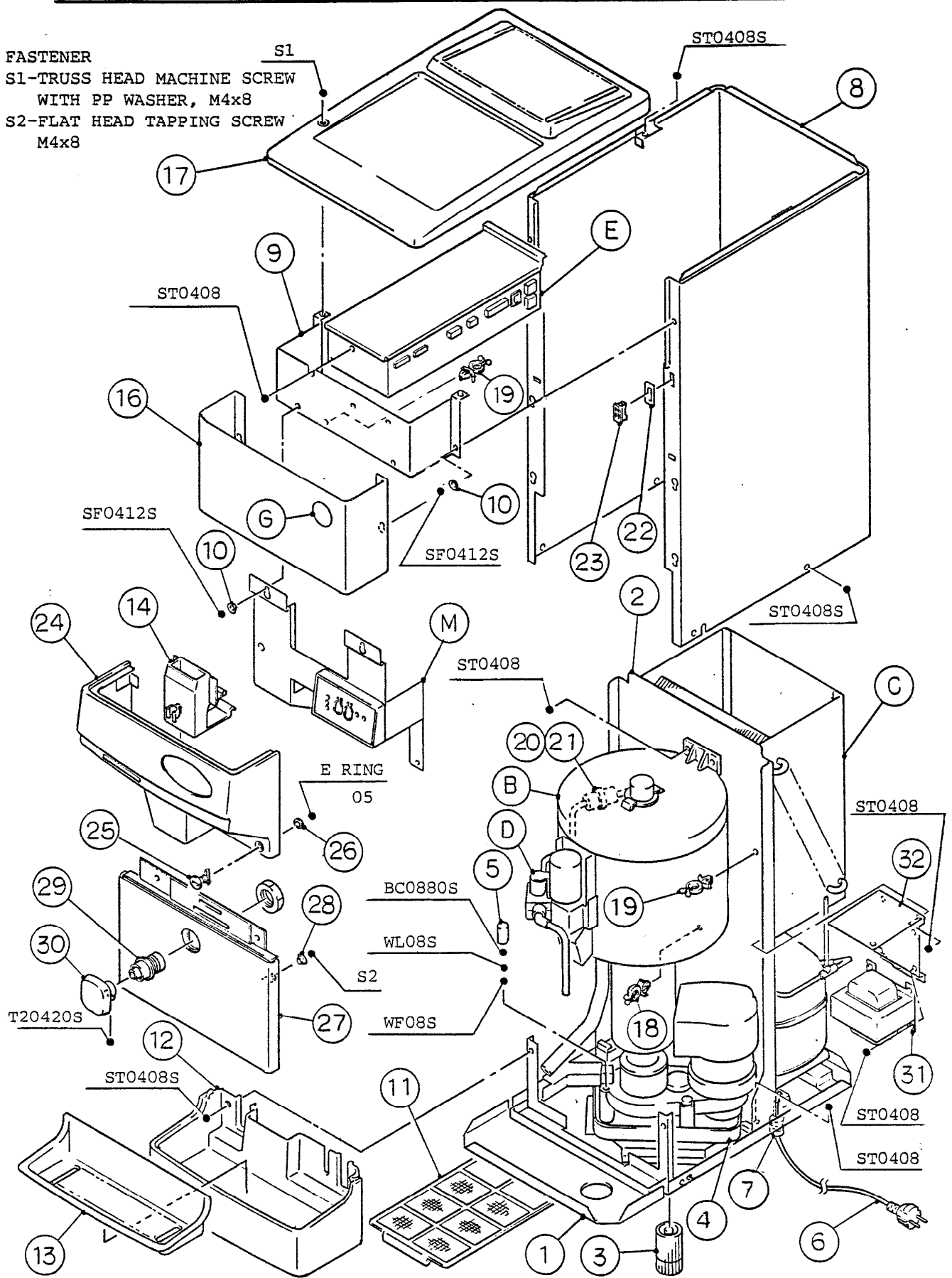

FASTENER
S1-TRUSS HEAD MACHINE SCREW
WITH PP WASHER, M4x8
S2-FLAT HEAD TAPPING SCREW
M4x8

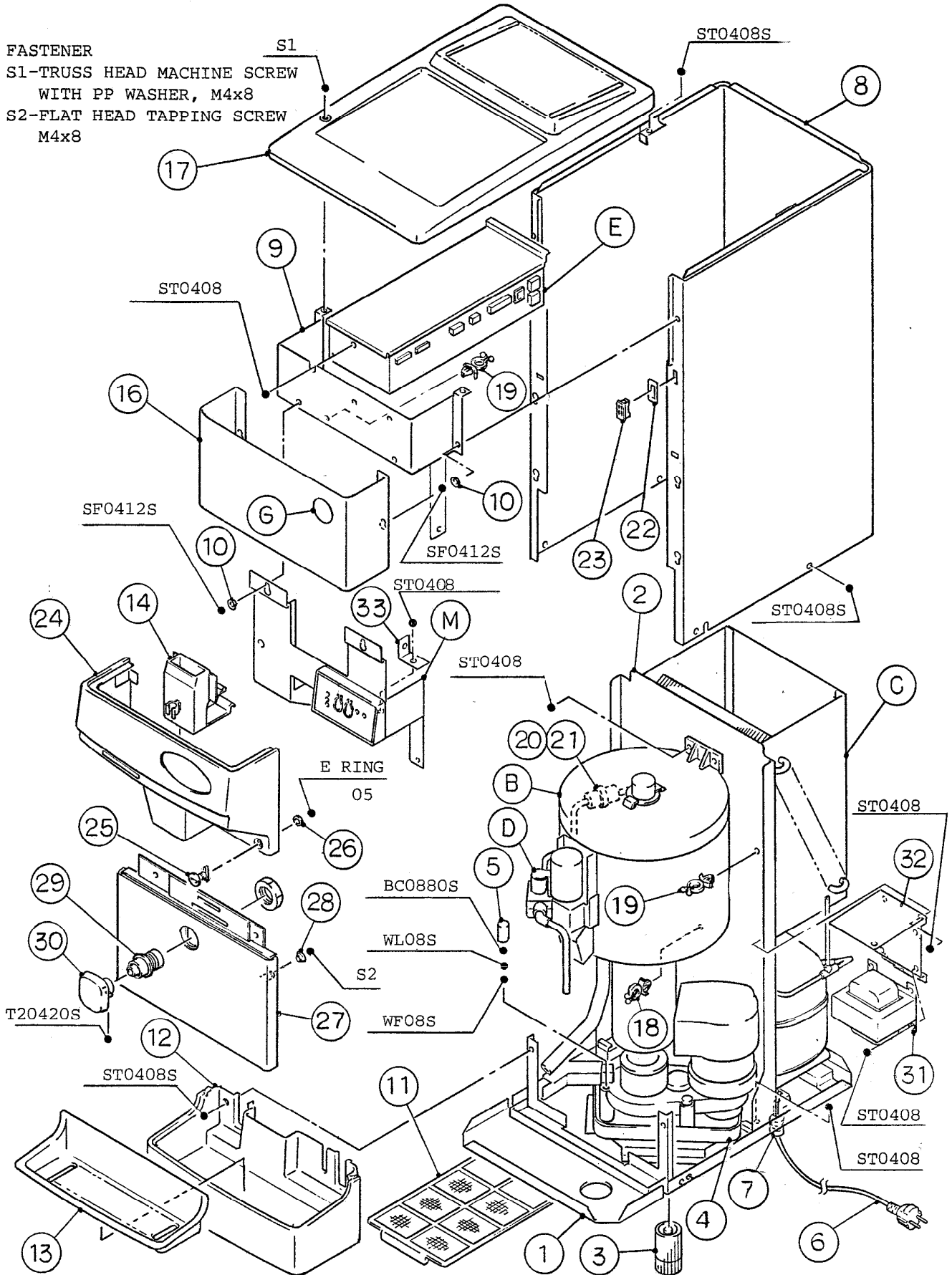

HE
DCM-120FE

A. ICE DISPENSER ASSY

(J-3)(J-4)

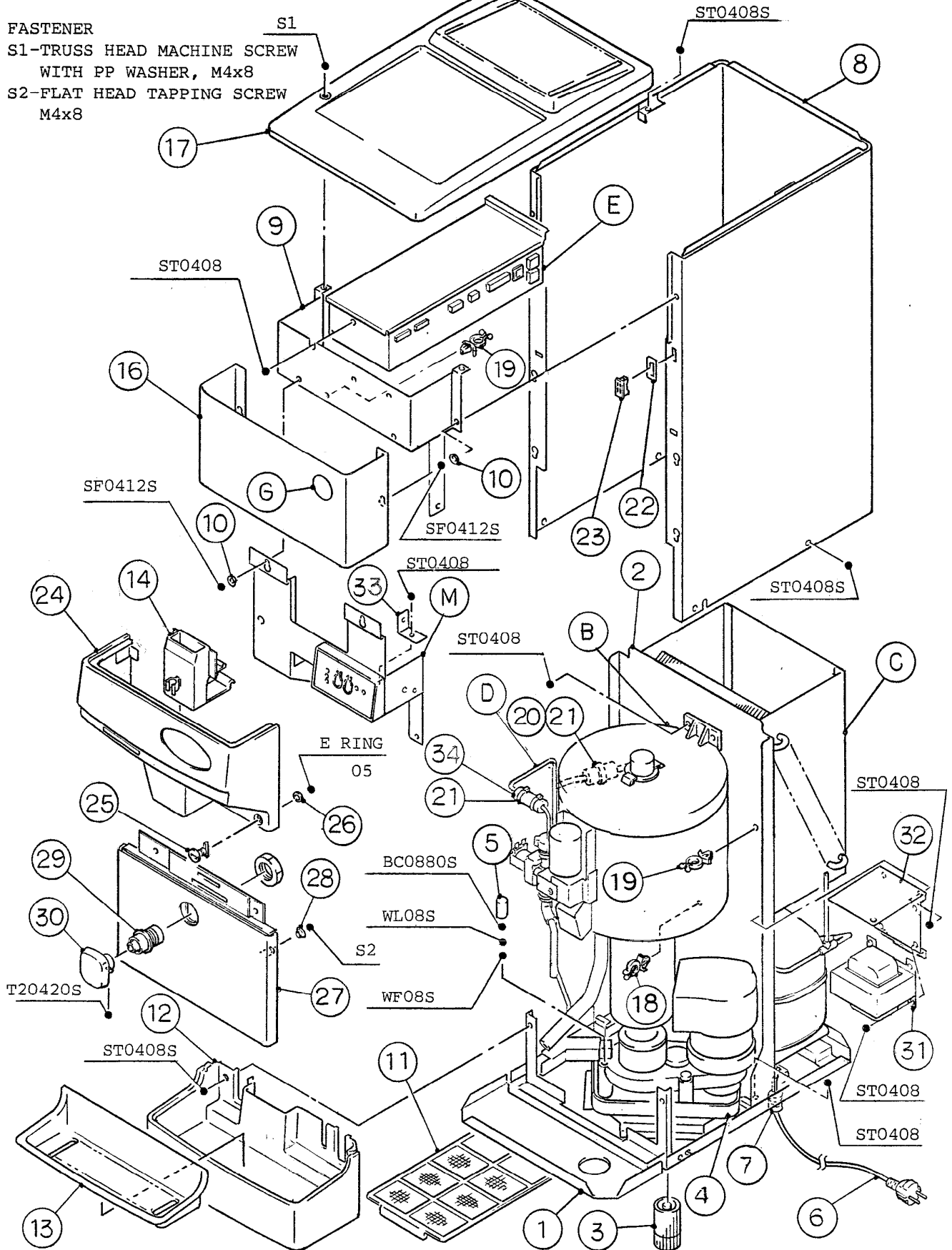

FASTENER
S1-TRUSS HEAD MACHINE SCREW
WITH PP WASHER, M4x8
S2-FLAT HEAD TAPPING SCREW
M4x8

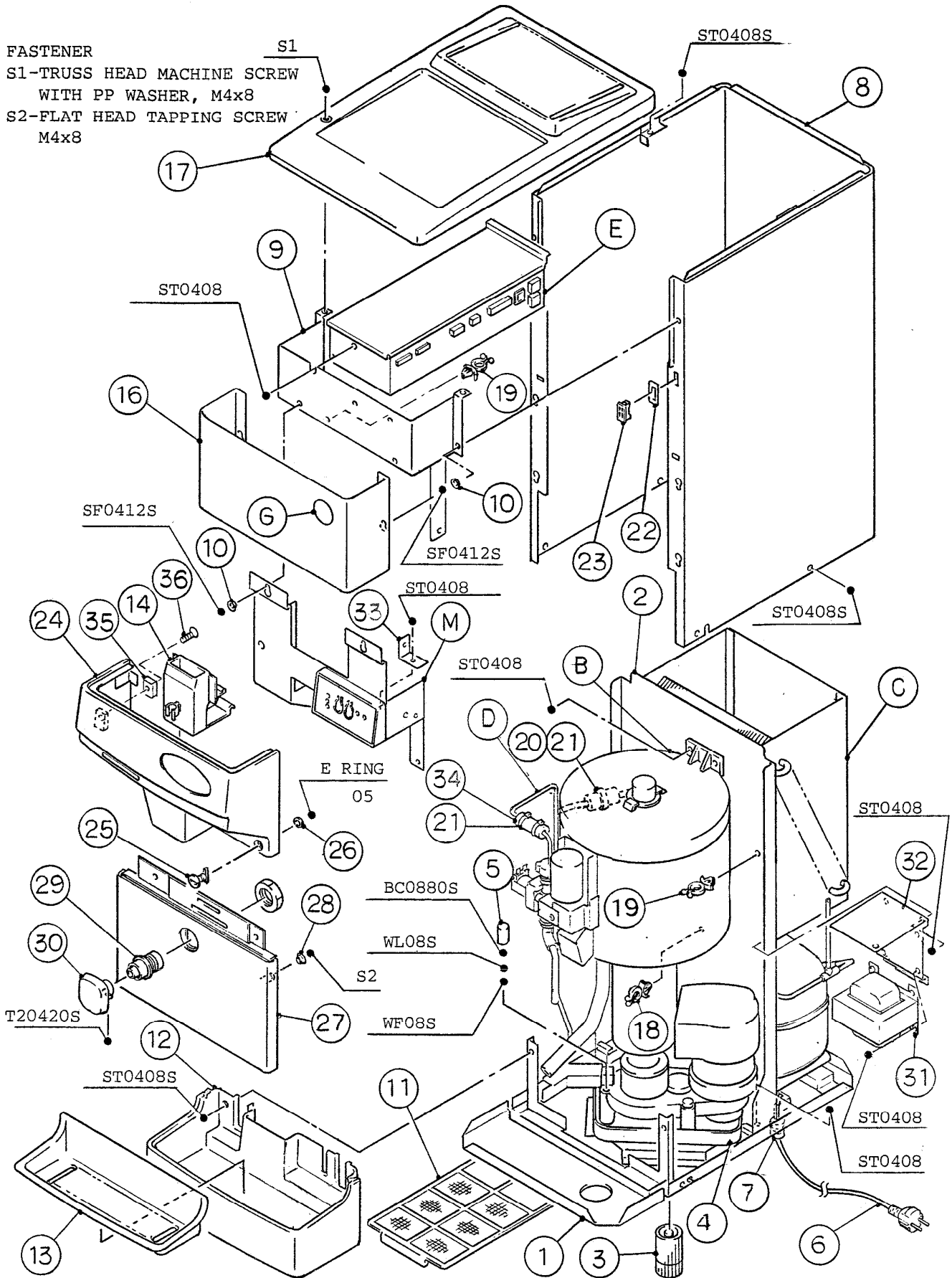

FASTENER
S1-TRUSS HEAD MACHINE SCREW
WITH PP WASHER, M4x8
S2-FLAT HEAD TAPPING SCREW
M4x8

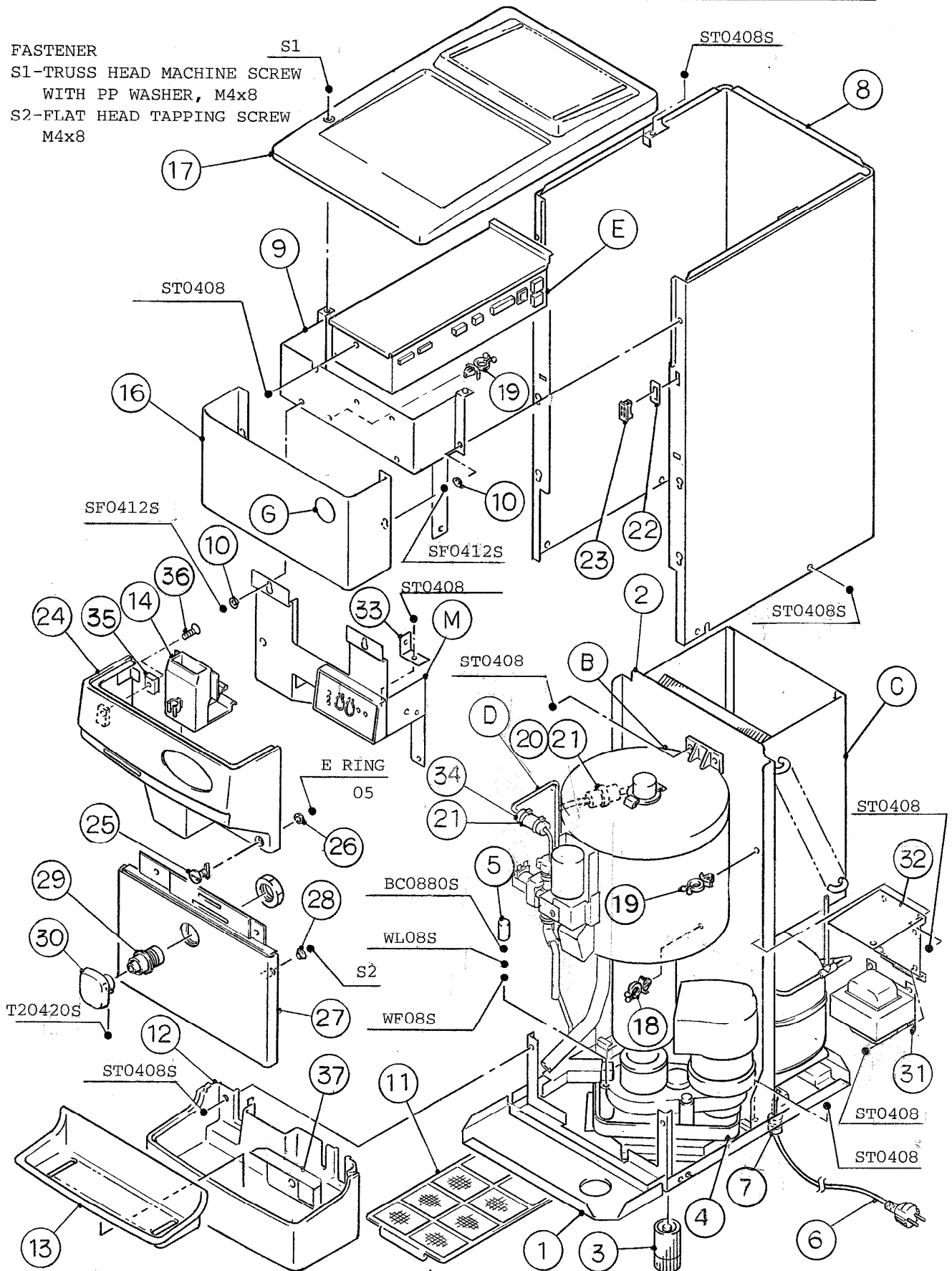

HE

MODEL: DCM-120FE		TITLE: A. ICE DISPENSER ASSY					
INDEX NO.	DESCRIPTION	MATERIAL OR MODEL NUMBER	PART NUMBER	REQ'D NUMBER			
				H-1	H-2 J-0	J-1	J-2
B	ICE MAKING UNIT	-	229689A01	1	1	-	
			229689A02			1	1
C	REFRIGERATION CIRCUIT	-	109499A01	1	1	x 1	
			109499A02			o 1	1
D	WATER CIRCUIT	-	109498A01	1	1	1	1
E	CONTROL BOX ASSY	-	229735A02	1	x 1		
			229735A03		o 1	1	1
F	APRON PANEL ASSY	-	229691A01	1	-		
			229691A02		x 1		
G	LABEL LOCATION	-	229736A01	1	1	-	
			231038A01			1	1
M	BRACKET (B) ASSY	-	343423A01		o 1	1	-
			343423A02				1
1	BASE	G.S	228738G03	1	1	1	1
2	PLATE	G.S	228764G02	1	1	1	1
3	LEG		455706-01	4	4	4	4
4	DRAIN PAN	ABS	318441-01	1	1	1	1
5	VINYL CAP	SH-108	451272-01	3	3	3	3
6	POWER SUPPLY CORD (CONTINENTAL)	GTCE-3	450412-01	1	1	1	1
	POWER SUPPLY CORD (UK)	CTBS-3	452359-01	1	1	1	1
7	BUSHING	CEE-SP6P10	448949-01	1	1	1	1
8	PANEL	S.S	230443G02	1	x 1		
		S.S	230443G04		o 1	1	1
9	BRACKET - TOP	G.S	341412-01	1	x 1		
		G.S	343425-01		o 1	1	1
10	COLLAR	S.S	4H0171-01	2	o 4	4	4
11	AIR FILTER	-	341489G01	1	1	1	1
12	DRAIN PANEL	ABS	109232-02	1	1	1	1
13	GRILLE	ABS	109231-02	1	1	1	1
14	GUIDE - SHUTTER	ABS	228910-01	1	x 1		
		PP	230748-01		o 1	1	1

HE

MODEL: DCM-120FE		TITLE: A. ICE DISPENSER ASSY					
INDEX NO.	DESCRIPTION	MATERIAL OR MODEL NUMBER	PART NUMBER	REQ'D NUMBER			
				J-3	J-4	J-5	K-1 A-0
B	ICE MAKING UNIT	-	229689A02	-			
			229689A03	1	1	1	1
C	REFRIGERATION CIRCUIT	-	109499A02	1	1	1	1
D	WATER CIRCUIT	-	109498A01	1	1	1	1
E	CONTROL BOX ASSY	-	229735A03	1	1	-	
			229735A04			1	1
F	-	-	-	-			
G	LABEL LOCATION	-	231038A01	1	1	1	1
M	BRACKET (B) ASSY	-	343423A02	-			
			343423A03	1	1	-	
			345346A01			1	1
1	BASE	G.S	228738G03	1	1	1	1
2	PLATE	G.S	228764G02	1	1	1	1
3	LEG		455706-01	4	4	4	4
4	DRAIN PAN	ABS	318441-01	1	1	1	1
5	VINYL CAP	SH-108	451272-01	3	3	3	3
6	POWER SUPPLY CORD (CONTINENTAL)	GTCE-3	450412-01	1	1	1	1
	POWER SUPPLY CORD (UK)	CTBS-3	452359-01	1	1	1	1
7	BUSHING	CEE-SP6P10	448949-01	1	1	1	1
8	PANEL	S.S	230443G04	1	1	1	1
9	BRACKET - TOP	G.S	343425-01	1	1	1	1
10	COLLAR	S.S	4H0171-01	4	4	4	4
11	AIR FILTER	-	341489G01	1	1	1	1
12	DRAIN PANEL	ABS	109232-02	1	1	1	1
13	GRILLE	ABS	109231-02	1	1	1	1
14	GUIDE - SHUTTER	PP	230748-01	1	1	1	1

HE

MODEL: DCM-120FE		TITLE: A. ICE DISPENSER ASSY					
INDEX NO.	DESCRIPTION	MATERIAL OR MODEL NUMBER	PART NUMBER	REQ'D NUMBER			
				A-1 B-1 B-2	B-3		
B	ICE MAKING UNIT	-	229689A03	1	-		
			229689A05		1		
C	REFRIGERATION CIRCUIT	-	109499A02	1	1		
D	WATER CIRCUIT	-	109498A01	1	1		
E	CONTROL BOX ASSY	-	229735A03	1	1		
			229735A04	1	1		
F							
G	LABEL LOCATION	-	231038A01	1	1		
M	BRACKET (B) ASSY	-	345346A01	1	1		
1	BASE	G.S	228738G03	1	1		
2	PLATE	G.S	228764G02	1	1		
3	LEG		455706-01	4	4		
4	DRAIN PAN	ABS	318441-01	1	1		
5	VINYL CAP	SH-108	451272-01	3	3		
6	POWER SUPPLY CORD (CONTINENTAL)	GTCE-3	450412-01	1	1		
	POWER SUPPLY CORD (UK)	CTBS-3	452359-01	1	1		
7	BUSHING	CEE-SP6P10	448949-01	1	1		
8	PANEL	S.S	230443G04	1	1		
9	BRACKET - TOP	G.S	343425-01	1	1		
10	COLLAR	S.S	4H0171-01	4	4		
11	AIR FILTER	-	341489G01	1	1		
12	DRAIN PANEL	ABS	109232-02	1	1		
13	GRILLE	ABS	109231-02	1	1		
14	GUIDE - SHUTTER	PP	230748-01	1	1		

HE

MODEL: DCM-120FE		TITLE: A. ICE DISPENSER ASSY					
INDEX NO.	DESCRIPTION	MATERIAL OR MODEL NUMBER	PART NUMBER	REQ'D NUMBER			
				H-1	H-2 J-0	J-1	J-2
15	GUIDE - APRON PANEL	ABS	228909-01	1	x 1		
		ABS	228909-02		o 1	1	1
16	FRONT PANEL	S.S	341410-01	1	x 1		
		S.S	343426-01		o 1	1	1
17	TOP PANEL	ABS	109229-01	1	x 1		
		ABS	109229-02		o 1	1	1
18	CLAMP	NO. 249	427902-03	1	1	1	1
19	CLAMP	NO. 4253	427902-05	4	o 5	6	6
20	INSULATION TUBE	L=50	7762-1020	1	x 1		
		L=50	109496-38		x 1		
		L=50	109793-19		o 1	1	1
21	TIE	CV-150	7920-0003	1	1	1	1
22	SPACER	S.S	456500-01		o 1	1	1
23	MAGNET CATCH	MC-340-T2	452935-01		o 2	2	2
24	APRON PANEL (A)	ABS	230789G01		o 1	1	1
25	SCREW	ALUMINUM	343385-01		o 2	2	2
26	WASHER	PTFE	456488-01		o 2	2	2
27	APRON PANEL (B)	ABS	109779G01		o 1	1	1
28	COLLAR	S.S	4H0171-01		o 4	4	4
29	PUSH SWITCH	HS-20	460111-01		o 1	1	1
30	PUSH LEVER	ABS	341617-02		o 1	1	1
31	TRANSFORMER	RY12-19738	455656-01	1	1	1	1
32	BRACKET - TRANSFORMER	G.S	454786-01	1	1	1	1
33	BRACKET		456991-01				1

HE

MODEL: DCM-120FE		TITLE: A. ICE DISPENSER ASSY					
INDEX NO.	DESCRIPTION	MATERIAL OR MODEL NUMBER	PART NUMBER	REQ'D NUMBER			
				J-3	J-4	J-5	K-1 A-0
15	GUIDE - APRON PANEL	ABS	228909-02	1	1	1	1
16	FRONT PANEL	S.S	343426-01	1	1	1	1
17	TOP PANEL	ABS	109229-02	1	1	1	1
18	CLAMP	NO. 249	427902-03	1	1	1	1
19	CLAMP	NO. 4253	427902-05	6	6	6	6
20	INSULATION TUBE	L=50	109793-19	1	1	1	1
21	TIE	CV-150	7920-0003	1	1	1	1
22	SPACER	S.S	456500-01	1	1	1	1
23	MAGNET CATCH	MC-340-T2	452935-01	2	2	2	2
24	APRON PANEL (A)	ABS	230789G01	1	1	-	
			230789G04			1	1
25	SCREW	ALUMINUM	343385-01	2	2	2	2
26	WASHER	PTFE	456488-01	2	2	2	2
27	APRON PANEL (B)	ABS	109779G01	1	1	1	1
28	COLLAR	S.S	4H0171-01	4	4	4	4
29	PUSH SWITCH	HS-20	460111-01	1	1	1	1
30	PUSH LEVER	ABS	341617-02	1	1	1	1
31	TRANSFORMER	RY12-19738	455656-01	1	1	1	1
32	BRACKET - TRANSFORMER	G.S	454786-01	1	1	1	1
33	BRACKET		456991-01	1	1	1	1
34	INSULATION TUBE	L=80	7762-1020		1	1	1
35	MAGNET		457962-01			1	1
36	TAPPING SCREW - FLAT HEAD		457963-01			1	1

HE

MODEL: DCM-120FE		TITLE: A. ICE DISPENSER ASSY					
INDEX NO.	DESCRIPTION	MATERIAL OR MODEL NUMBER	PART NUMBER	REQ'D NUMBER			
				A-1 B-1 B-2	B-3		
15	GUIDE - APRON PANEL	ABS	228909-02	1	1		
16	FRONT PANEL	S.S	343426-01	1	1		
17	TOP PANEL	ABS	109229-02	1	1		
18	CLAMP	NO. 249	427902-03	1	1		
19	CLAMP	NO. 4253	427902-05	6	6		
20	INSULATION TUBE	L=50	109793-19	1	1		
21	TIE	CV-150	7920-0003	1	1		
22	SPACER	S.S	456500-01	1	1		
23	MAGNET CATCH	MC-340-T2	452935-01	2	2		
24	APRON PANEL (A)	ABS	230789G01	-			
			230789G04	1	1		
25	SCREW	ALUMINUM	343385-01	2	2		
26	WASHER	PTFE	456488-01	2	2		
27	APRON PANEL (B)	ABS	109779G01	1	1		
28	COLLAR	S.S	4H0171-01	4	4		
29	PUSH SWITCH	HS-20	460111-01	1	1		
30	PUSH LEVER	ABS	341617-02	1	1		
31	TRANSFORMER	RY12-19738	455656-01	1	1		
32	BRACKET - TRANSFORMER	G.S	454786-01	1	1		
33	BRACKET		456991-01	1	1		
34	INSULATION TUBE	L=80	7762-1020	1	1		
35	MAGNET		457962-01	1	1		
36	TAPPING SCREW - FLAT HEAD		457963-01	1	1		
37	BRACKET - DRAIN		351111-01	1	1		

HE
DCM-120FE

B. ICE MAKING UNIT

(J-4) (J-5)
(J-3) (J-2) (J-1)
(H-1) (H-2) (J-0)

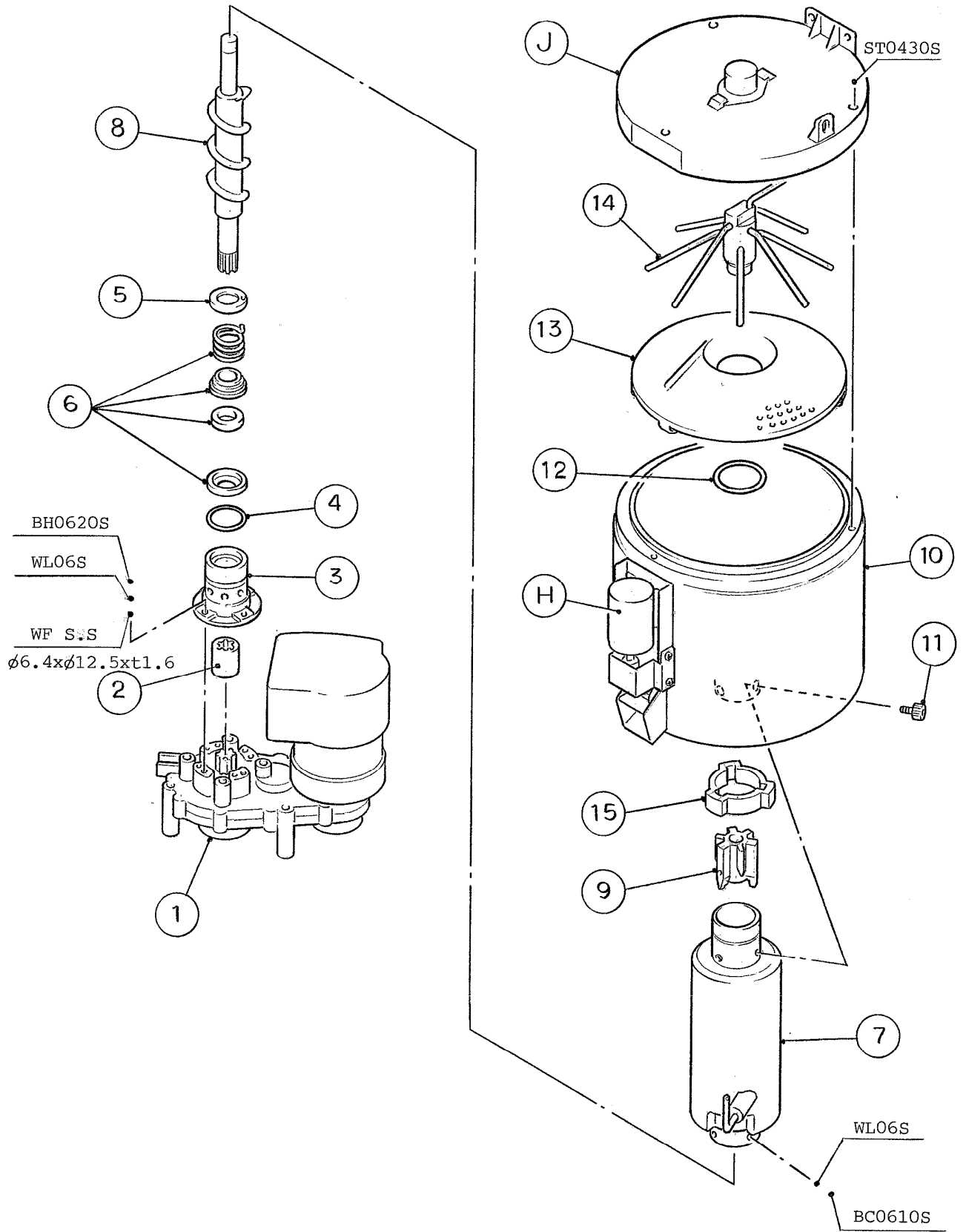

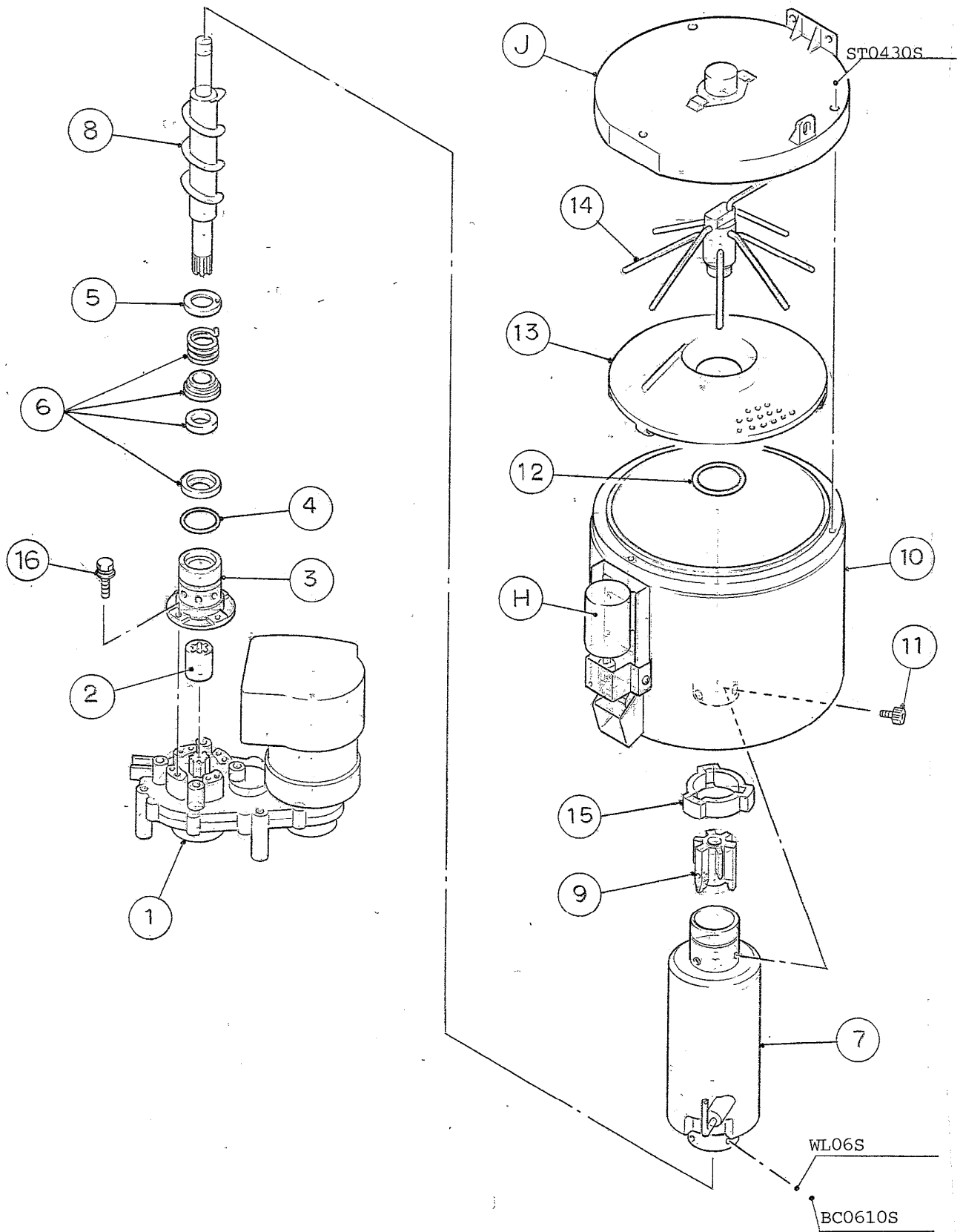

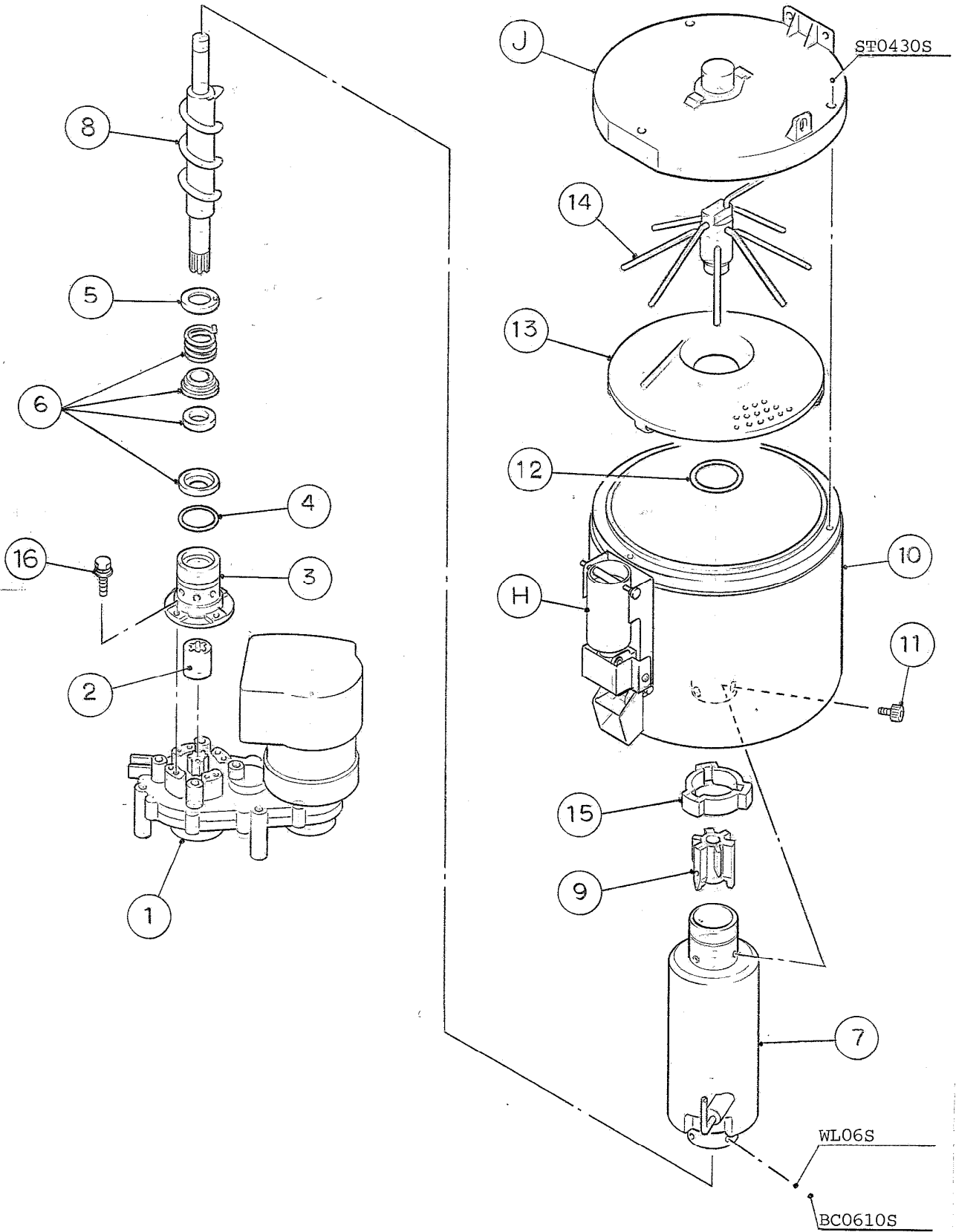

HE

MODEL: DCM-120FE TITLE: B. ICE MAKING UNIT							
INDEX NO.	DESCRIPTION	MATERIAL OR MODEL NUMBER	PART NUMBER	REQ'D NUMBER			
				H-1	H-2 J-0	J-1	J-2
H	SHUTTER ASSY	-	228920A01	1	1	1	1
J	COVER ASSY - BIN TOP	-	228513A01	1	1	1	1
1	GEAR MOTOR	TC1149, 100V 80W	450455-01	1	1	1	1
2	COUPLING - SPLINE	S.S	418316-01	1	1	1	1
3	HOUSING	COPPER ALLOY	206013G03	1	1	1	1
4	"O" RING		7616-G040	1	1	1	1
5	RING (B)	S.S	432494-01	1	1	1	1
6	MECHANICAL SEAL	HK9A-MS	432491-01	1	1	1	1
7	EVAPORATOR - INSULATION AD	-	341259G01	1	1	1	1
8	AUGER	S.S	341449G01	1	1	1	1
9	EXTRUDING HEAD - 45C	S.S	327236G02	1	1	1	1
10	INSULATION - BIN	-	228516G01	1	1	1	1
11	SOCKET HEAD CAP SCREW	S.S, 8x14	429121-01	3	3	3	3
12	"O" RING		7616-P048	1	1	1	1
13	DRIP RING	S.S	207754-01	1	1	1	1
14	AGITATOR	S.S	314997G02	1	1	1	1
15	COVER - UPPER, EVAPORATOR	PE FOAM	413446-01	1	1	1	1

HE

MODEL: DCM-120FE TITLE: B. ICE MAKING UNIT							
INDEX NO.	DESCRIPTION	MATERIAL OR MODEL NUMBER	PART NUMBER	REQ'D NUMBER			
				J-3	J-4J	J-5	K-1 A-0
H	SHUTTER ASSY	-	228920A01	1	1	1	1
J	COVER ASSY - BIN TOP	-	228513A01	1	1	1	1
1	GEAR MOTOR	TC1149, 100V 80W	450455-01	1	1	1	1
2	COUPLING - SPLINE	S.S	418316-01	1	1	1	1
3	HOUSING	COPPER ALLOY	206013G03	1	1	1	1
4	"O" RING		7616-G040	1	1	1	1
5	RING (B)	S.S	432494-01	1	1	1	1
6	MECHANICAL SEAL	HK9A-MS	432491-01	1	1	1	1
7	EVAPORATOR - INSULATION AD	-	341259G01	1	1	1	1
8	AUGER	S.S	341449G01	1	1	1	1
9	EXTRUDING HEAD - 45C	S.S	327236G02	1	1	1	1
10	INSULATION - BIN	-	228516G01	1	1	1	1
11	SOCKET HEAD CAP SCREW	S.S, 8x14	429121-01	3	3	3	3
12	"O" RING		7616-P048	1	1	1	1
13	DRIP RING	S.S	207754-01	1	1	1	1
14	AGITATOR	S.S	314997G02	1	1	1	1
15	COVER - UPPER, EVAPORATOR	PE FOAM	413446-01	1	1	1	1
16	BOLT						4

HE

MODEL: DCM-120FE TITLE: B. ICE MAKING UNIT							
INDEX NO.	DESCRIPTION	MATERIAL OR MODEL NUMBER	PART NUMBER	REQ'D NUMBER			
				A-1 B-1 B-2	B-3		
H	SHUTTER ASSY	-	228920A01	1	-		
			237274A01		1		
J	COVER ASSY - BIN TOP	-	228513A01	1	1		
1	GEAR MOTOR	TC1149, 100V 80W	450455-01	1	1		
2	COUPLING - SPLINE	S.S	418316-01	1	1		
3	HOUSING	COPPER ALLOY	206013G03	1	1		
4	"O" RING		7616-G040	1	1		
5	RING (B)	S.S	432494-01	1	1		
6	MECHANICAL SEAL	HK9A-MS	432491-01	1	1		
7	EVAPORATOR - INSULATION AD	-	341259G01	1	1		
8	AUGER	S.S	341449G01	1	1		
9	EXTRUDING HEAD - 45C	S.S	327236G02	1	1		
10	INSULATION - BIN	-	228516G01	1	1		
11	SOCKET HEAD CAP SCREW	S.S, 8x14	429121-01	3	3		
12	"O" RING		7616-P048	1	1		
13	DRIP RING	S.S	207754-01	1	1		
14	AGITATOR	S.S	314997G02	-			
			348969G01	1	1		
15	COVER - UPPER, EVAPORATOR	PE FOAM	413446-01	1	1		
16	BOLT		458660-01	4	4		

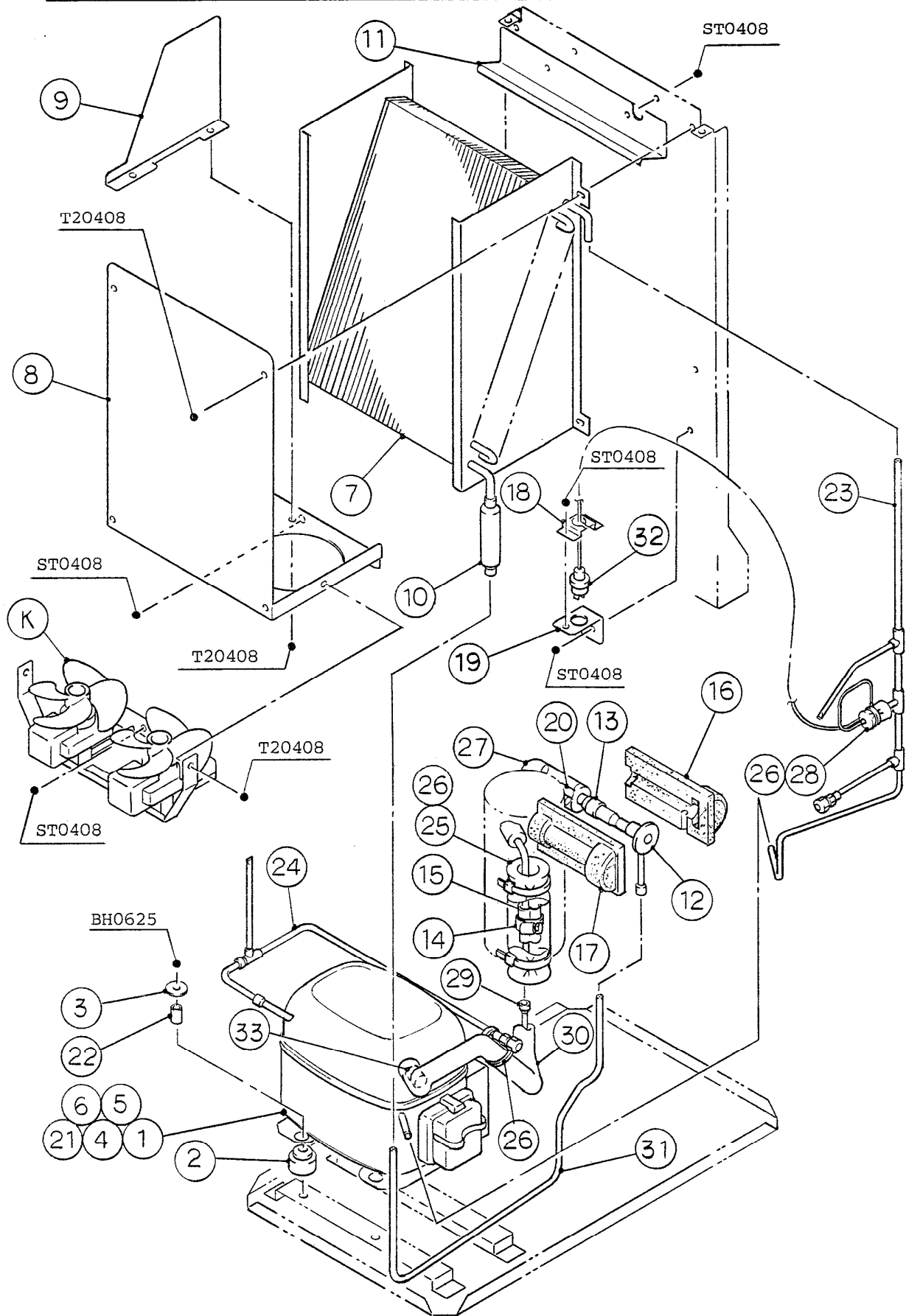

HE
DCM-120FE

C. REFRIGERATION CIRCUIT

(B-2)(B-3)
(A-0)(A-1)(B-1)
(J-4)(J-5)(K-1)
(J-1)(J-2)(J-3)

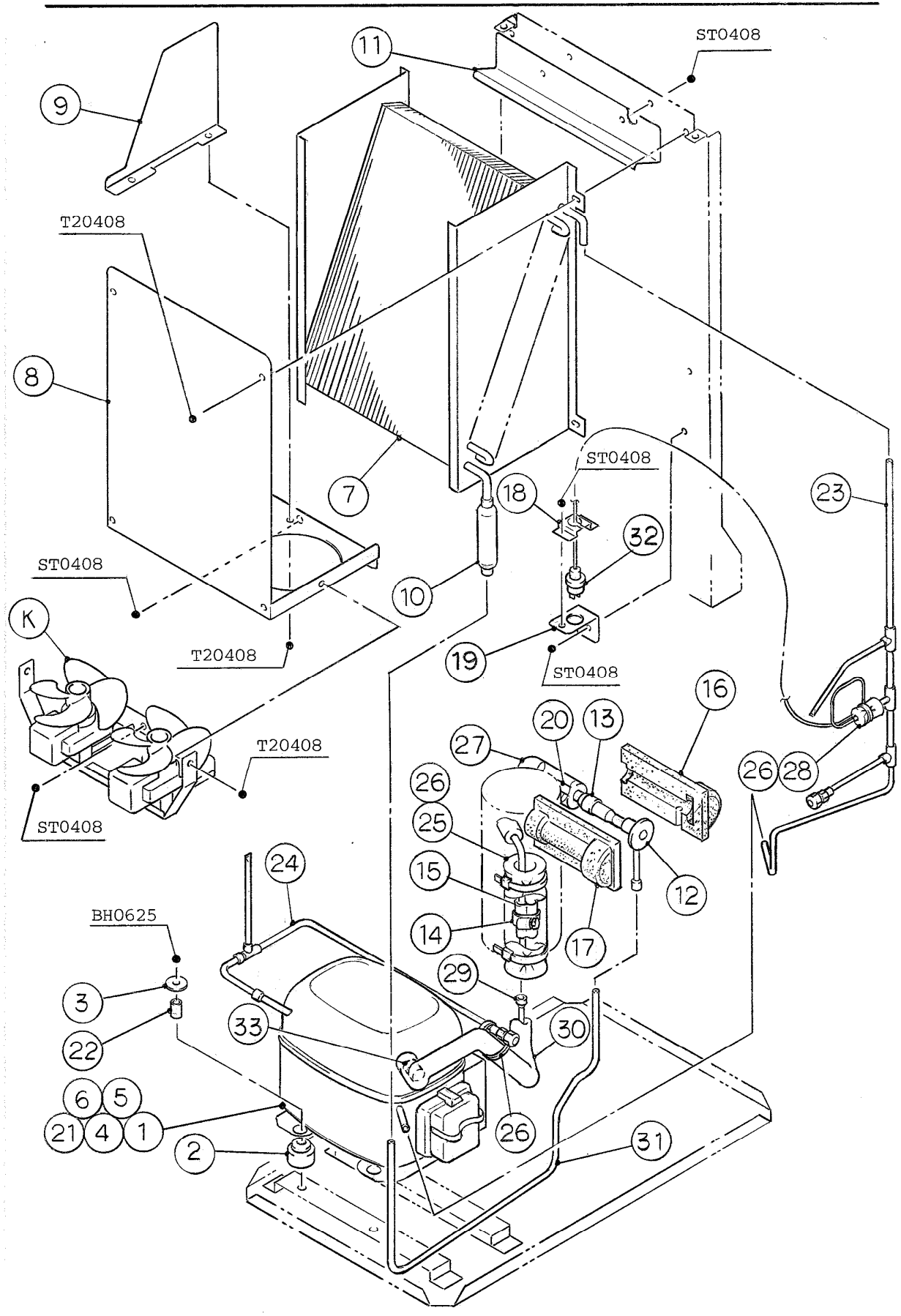

HE

MODEL: DCM-120FE				TITLE: C. REFRIGERATION CIRCUIT			
INDEX NO.	DESCRIPTION	MATERIAL OR MODEL NUMBER	PART NUMBER	REQ'D NUMBER			
				H-1	H-2 J-0	J-1	J-2
K	FAN MOTOR ASSY	-	228777A01	1	1	1	1
1	COMPRESSOR	SC15G	455606-01	1	1	1	1
2	GROMMET		450897-01	4	4	4	4
3	WASHER CUSHION		450894-01	1	1	1	1
4	START CAPACITOR		452238-01	1	1	-	
		117U5017	456350-01			1	1
5	STARTER	117U6005	455607-01	1	1	1	1
6	CORD RELIEF	103N1004	452239-01	1	1	1	1
7	CONDENSER	-	109205-01	1	1	1	1
8	SHROUD	G.S	341306-01	1	1	1	1
9	SHROUD (B)	G.S	454829-01	1	1	1	1
10	DRIER	DY-15QHD-5	458776-01	1	1	1	1
11	BARRIER - CONDENSER	G.S	454777-01	1	1	1	1
12	EXPANSION VALVE	HFE-5QHD-1	446808-01	1	1	1	1
13	REDUCER	COPPER	421904-01	1	1	1	1
14	CLAMP	S.S	443461-01	1	1	1	1
15	HOLDER - EXPANSION VALVE	S.S	451267-01	1	1	1	1
16	COVER (A) - EXPANSION VALVE	PE FOAM	324313-01	1	1	1	1
17	COVER (B) - EXPANSION VALVE	PE FOAM	324313-02	1	1	1	1
18	BRACKET (A) - PRESSURE SWITCH	G.S	425506-01	1	1	1	1
19	BRACKET (B) - PRESSURE SWITCH	G.S	455309-01	1	1	1	1
20	COPPER TUBE - L3	COPPER	454880-02	1	1	1	1
21	COVER	103N2002	452240-01	1	1	1	1
22	BUSH CUSHION		450895-01	4	4	4	4
23	COPPER TUBE - H1	COPPER	341355G01	1	1	-	
		COPPER	341355G02			1	1
24	COPPER TUBE - L2	COPPER	341357G01	1	1	1	1
25	INSULATION TUBE	7762-2949, L=150	109499-37	1	1	1	1
26	TIE	CV-150	7920-0003	5	o 4	4	4
27	INSULATION TUBE	7762-1030, L=270	109499-39	1	1	1	1
28	INSULATION TUBE	7762-0717, L=30	109499-40	1	1	1	1
29	COPPER TUBE	COPPER	341354-01	1	1	1	1
30	INSULATION TUBE	L=450	7762-1030	1	1	1	1
31	COPPER TUBE - H2	COPPER	341536-01	1	1	1	1

HE

MODEL: DCM-120FE		TITLE: C. REFRIGERATION CIRCUIT					
INDEX NO.	DESCRIPTION	MATERIAL OR MODEL NUMBER	PART NUMBER	REQ'D NUMBER			
				J-3	J-4	J-5	K-1 A-0
K	FAN MOTOR ASSY	-	228777A01	1	1	1	1
1	COMPRESSOR	SC15G	455606-01	1	1	1	1
2	GROMMET		450897-01	4	4	4	4
3	WASHER CUSHION		450894-01	1	1	1	1
4	START CAPACITOR	117U5017	456350-01	1	1	1	1
5	STARTER	117U6005	455607-01	1	1	1	1
6	CORD RELIEF	103N1004	452239-01	1	1	1	1
7	CONDENSER	-	109205-01	1	1	1	1
8	SHROUD	G.S	341306-01	1	1	1	1
9	SHROUD (B)	G.S	454829-01	1	1	1	1
10	DRIER	DY-15QHD-5	458776-01	1	1	1	1
11	BARRIER - CONDENSER	G.S	454777-01	1	1	1	1
12	EXPANSION VALVE	HFE-5QHD-1	446808-01	1	1	1	1
13	REDUCER	COPPER	421904-01	1	1	1	1
14	CLAMP	S.S	443461-01	1	1	1	1
15	HOLDER - EXPANSION VALVE	S.S	451267-01	1	1	1	1
16	COVER (A) - EXPANSION VALVE	PE FOAM	324313-01	1	1	1	1
17	COVER (B) - EXPANSION VALVE	PE FOAM	324313-02	1	1	1	1
18	BRACKET (A) - PRESSURE SWITCH	G.S	425506-01	1	1	1	1
19	BRACKET (B) - PRESSURE SWITCH	G.S	455309-01	1	1	1	1
20	COPPER TUBE - L3	COPPER	454880-02	1	1	1	1
21	COVER	103N2002	452240-01	1	1	1	1
22	BUSH CUSHION		450895-01	4	4	4	4
23	COPPER TUBE - H1	COPPER	341355G02	1	1	1	1
24	COPPER TUBE - L2	COPPER	341357G01	1	1	1	1
25	INSULATION TUBE	7762-2949, L=150	109499-37	1	1	1	1
26	TIE	CV-150	7920-0003	4	4	4	4
27	INSULATION TUBE	7762-1030 , L=270	109499-39	1	1	1	1
28	INSULATION TUBE	7762-0717, L=30	109499-40	1	1	1	1
29	COPPER TUBE	COPPER	341354-01	1	1	1	1
30	INSULATION TUBE	L=450	7762-1030	1	1	1	1
31	COPPER TUBE - H2	COPPER	341536-01	1	1	1	1

HE

MODEL: DCM-120FE		TITLE: C. REFRIGERATION CIRCUIT					
INDEX NO.	DESCRIPTION	MATERIAL OR MODEL NUMBER	PART NUMBER	REQ'D NUMBER			
				A-1 B-1 B-2	B-3		
K	FAN MOTOR ASSY	-	228777A01	1	1		
1	COMPRESSOR	SC15G	455606-01	1	1		
2	GROMMET		450897-01	4	4		
3	WASHER CUSHION		450894-01	1	1		
4	START CAPACITOR	117U5017	456350-01	1	1		
5	STARTER	117U6005	455607-01	1	1		
6	CORD RELIEF	103N1004	452239-01	1	1		
7	CONDENSER	-	109205-01	1	1		
8	SHROUD	G.S	341306-01	1	1		
9	SHROUD (B)	G.S	454829-01	1	1		
10	DRIER	DY-15QHD-5	458776-01	1	1		
11	BARRIER - CONDENSER	G.S	454777-01	1	1		
12	EXPANSION VALVE	HFE-5QHD-1	446808-01	1	1		
13	REDUCER	COPPER	421904-01	1	1		
14	CLAMP	S.S	443461-01	1	1		
15	HOLDER - EXPANSION VALVE	S.S	451267-01	1	1		
16	COVER (A) - EXPANSION VALVE	PE FOAM	324313-01	1	1		
17	COVER (B) - EXPANSION VALVE	PE FOAM	324313-02	1	1		
18	BRACKET (A) - PRESSURE SWITCH	G.S	425506-01	1	1		
19	BRACKET (B) - PRESSURE SWITCH	G.S	455309-01	1	1		
20	COPPER TUBE - L3	COPPER	454880-02	1	1		
21	COVER	103N2002	452240-01	1	1		
22	BUSH CUSHION		450895-01	4	4		
23	COPPER TUBE - H1	COPPER	341355G02	1	1		
24	COPPER TUBE - L2	COPPER	341357G01	1	1		
25	INSULATION TUBE	7762-2949, L=150	109499-37	1	1		
26	TIE	CV-150	7920-0003	4	4		
27	INSULATION TUBE	7762-1030, L=270	109499-39	1	1		
28	INSULATION TUBE	7762-0717, L=30	109499-40	1	1		
29	COPPER TUBE	COPPER	341354-01	1	1		
30	INSULATION TUBE	L=450	7762-1030	1	1		
31	COPPER TUBE - H2	COPPER	341536-01	1	1		

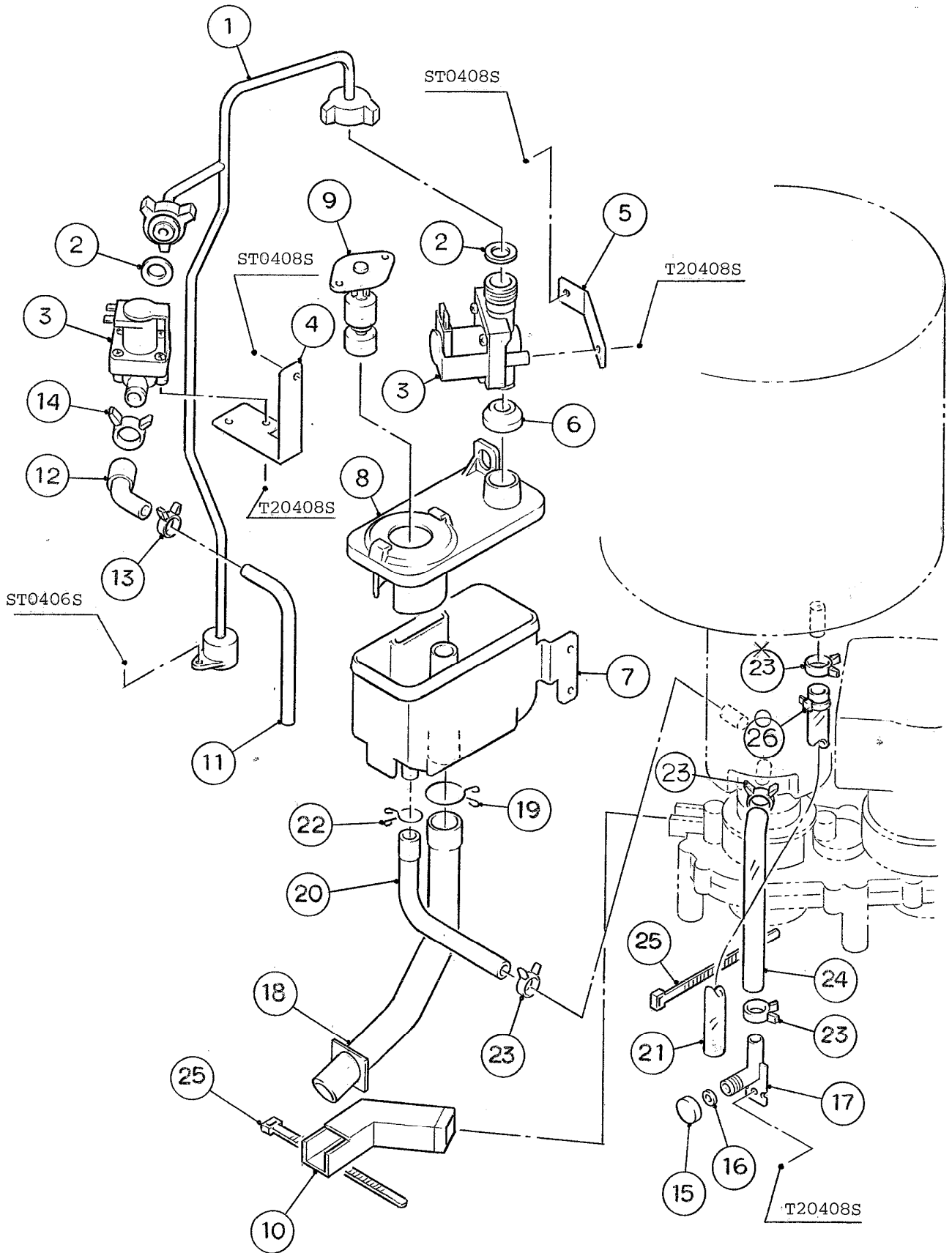

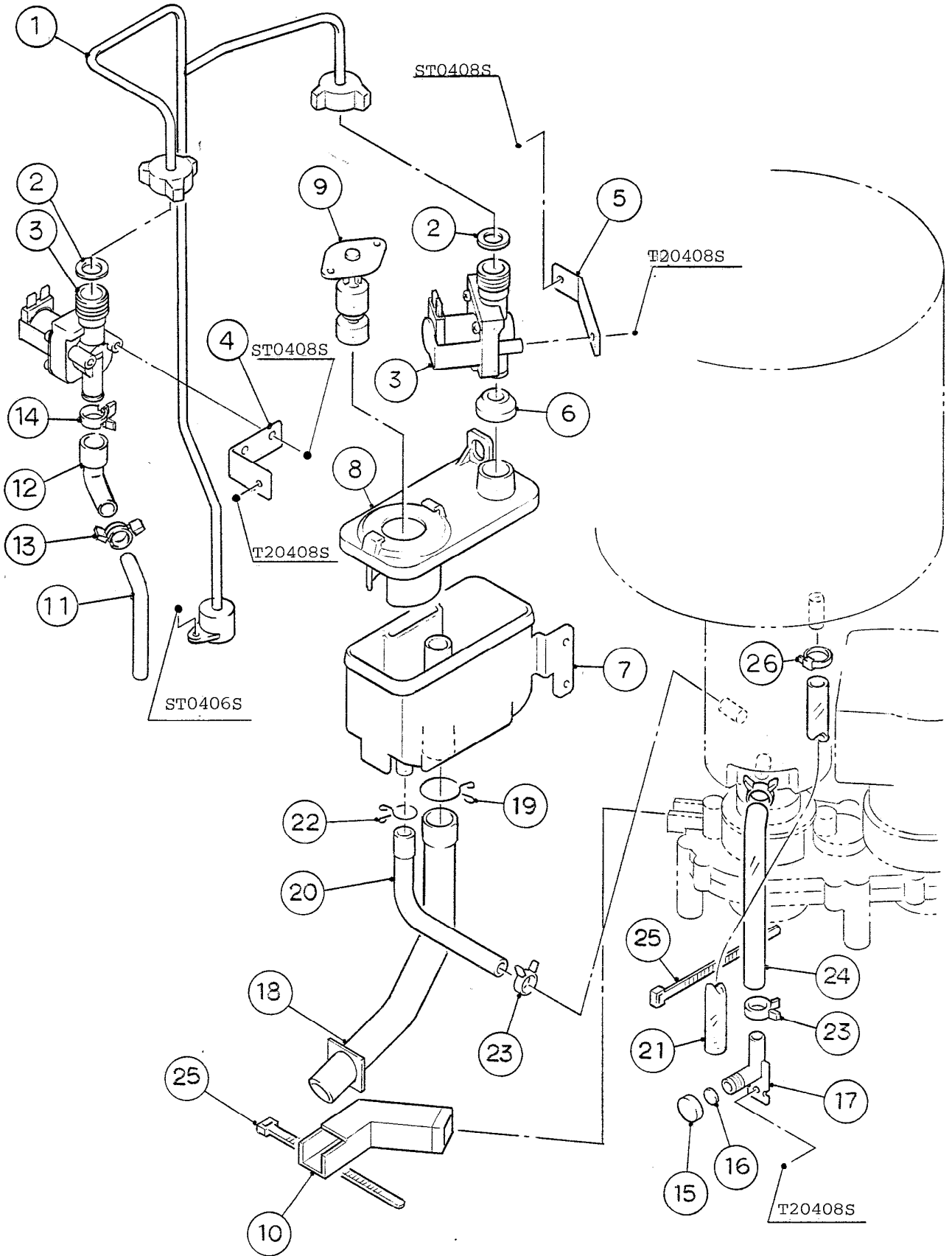

HE

MODEL: DCM-120FE				TITLE: D. WATER CIRCUIT			
INDEX NO.	DESCRIPTION	MATERIAL OR MODEL NUMBER	PART NUMBER	REQ'D NUMBER			
				H-1	H-2 J-0	J-1	J-2
1	PIPE - WATER SUPPLY	S.S	341528G01	1	1	1	1
2	PACKING	SI. R	413854-02	2	2	2	2
3	WATER VALVE	J246-198E	455812-01	2	2	2	2
4	BRACKET (A) - VALVE	S.S	455059-01	1	1	1	1
5	BRACKET (B) - VALVE	S.S	455047-01	1	1	1	1
6	COVER - RESERVOIR INLET	SI. R	415094-01	1	1	1	1
7	RESERVOIR	ABS	217620-01	1	1	1	1
8	COVER - RESERVOIR	ABS	217621-01	1	1	1	1
9	FLOAT SWITCH	TW-1221-101	435490-01	1	1	1	1
10	DRAIN PIPE	EPDM	454788-01	1	1	1	1
11	WATER PIPE	S.S	454881-01	1	1	1	1
12	JOINT HOSE	SILICONE	454882-01	1	1	1	1
13	CLIP BAND (A)	T14	423866-01	1	1	1	1
14	CLIP BAND (B)	T19	423866-02	1	1	1	1
15	CAP - DRAIN	C3602BD	454963-01	1	1	1	1
16	PACKING - DRAIN	SY. R	418071-03	1	1	1	1
17	PIPE - DRAIN	S.S	454964G01	1	1	1	1
18	PIPE - OVERFLOW	EPDM	342085-01	1	1	1	1
19	CLAMP	SK-25	435934-07	1	1	1	1
20	PIPE - TANK	SILICONE	455588-01	1	1	1	1
21	HOSE	7716-1216 , L=350	109498-35	1	1	1	1
22	CLAMP	SK-15	435934-03	1	1	1	1
23	CLIP BAND	T15	423866-04	4	4	3	3
24	HOSE	7716-1216 , L=125	109498-28	1	1	1	1
25	TIE	CV-250	7920-0011	2	2	2	2
26	TIE	CV-150	7920-0003			1	1

HE

MODEL: DCM-120FE		TITLE: D. WATER CIRCUIT					
INDEX NO.	DESCRIPTION	MATERIAL OR MODEL NUMBER	PART NUMBER	REQ'D NUMBER			
				A-1 B-1 B-2	B-3		
1	PIPE - WATER SUPPLY	S.S	344566G01	1	1		
2	PACKING	SI. R	413854-02	2	2		
3	WATER VALVE	J246-198E	455812-01	2	2		
4	BRACKET (A) - VALVE	S.S	455059-01	1	1		
5	BRACKET (B) - VALVE	S.S	455047-01	1	1		
6	COVER - RESERVOIR INLET	SI. R	415094-01	1	1		
7	RESERVOIR	ABS	217620-01	1	1		
8	COVER - RESERVOIR	ABS	217621-01	1	1		
9	FLOAT SWITCH	TW-1221-101	435490-01	1	1		
10	DRAIN PIPE	EPDM	454788-01	1	1		
11	WATER PIPE	S.S	457277-01	1	1		
12	JOINT HOSE	SILICONE	457276-01	1	1		
13	CLIP BAND (A)	T14	423866-01	1	1		
14	CLIP BAND (B)	T19	423866-02	1	1		
15	CAP - DRAIN	C3602BD	454963-01	1	1		
16	PACKING - DRAIN	SY. R	418071-03	1	1		
17	PIPE - DRAIN	S.S	454964G01	1	1		
18	PIPE - OVERFLOW	EPDM	342085-01	1	1		
19	CLAMP	SK-25	435934-07	1	1		
20	PIPE - TANK	SILICONE	455588-01	1	1		
21	HOSE	7716-1216 , L=350	109498-35	1	1		
22	CLAMP	SK-15	435934-03	1	1		
23	CLIP BAND	T15	423866-04	4	4		
24	HOSE	7716-1216 , L=125	109498-28	1	1		
25	TIE	CV-250	7920-0011	2	2		
26	TIE	CV-150	7920-0003	1	1		

HE
DCM-120FE

E. CONTROL BOX ASSY

(J-5) (J-4)
(J-3) (J-2) (J-1)
(H-1) (H-2) (J-0)

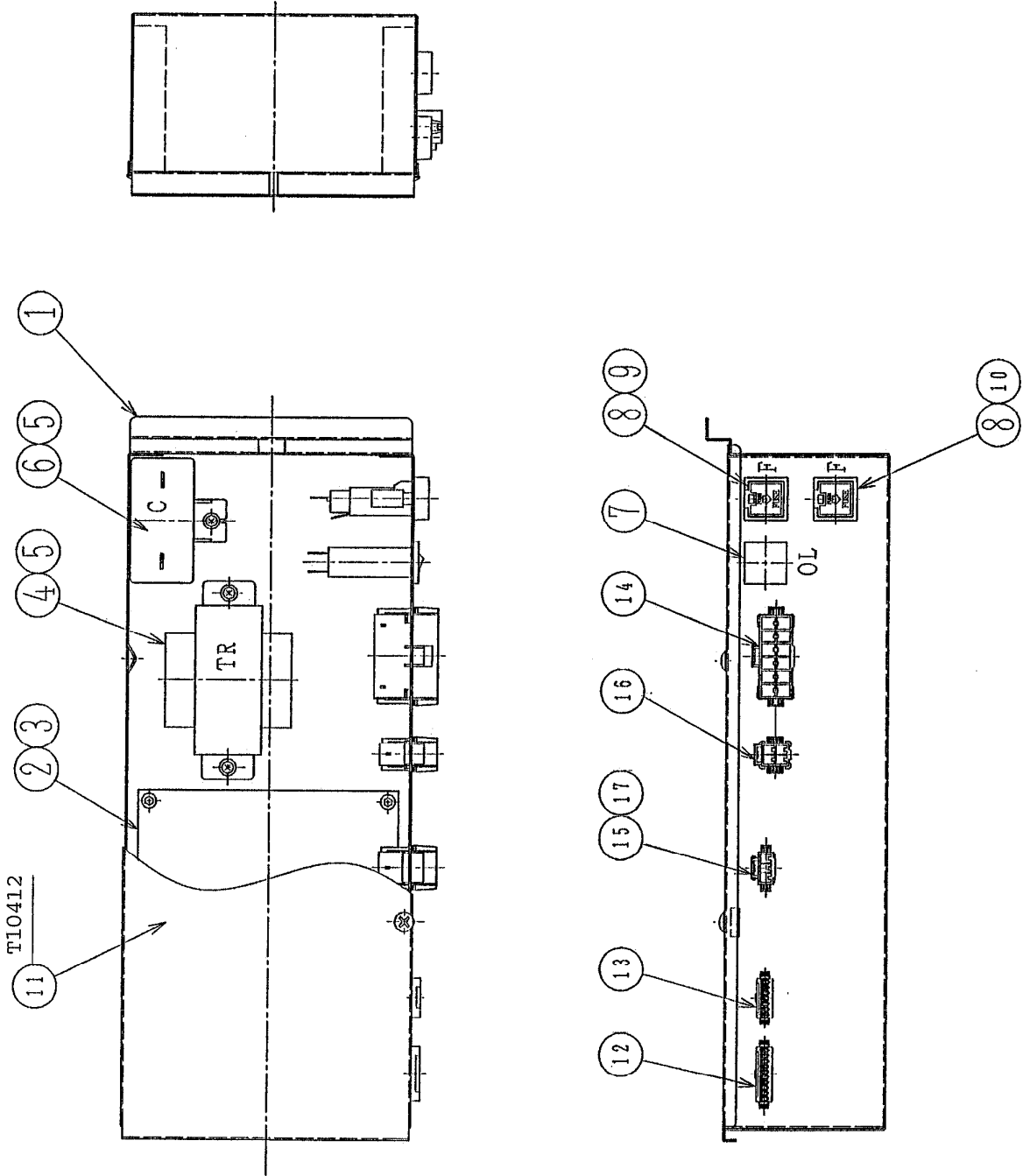

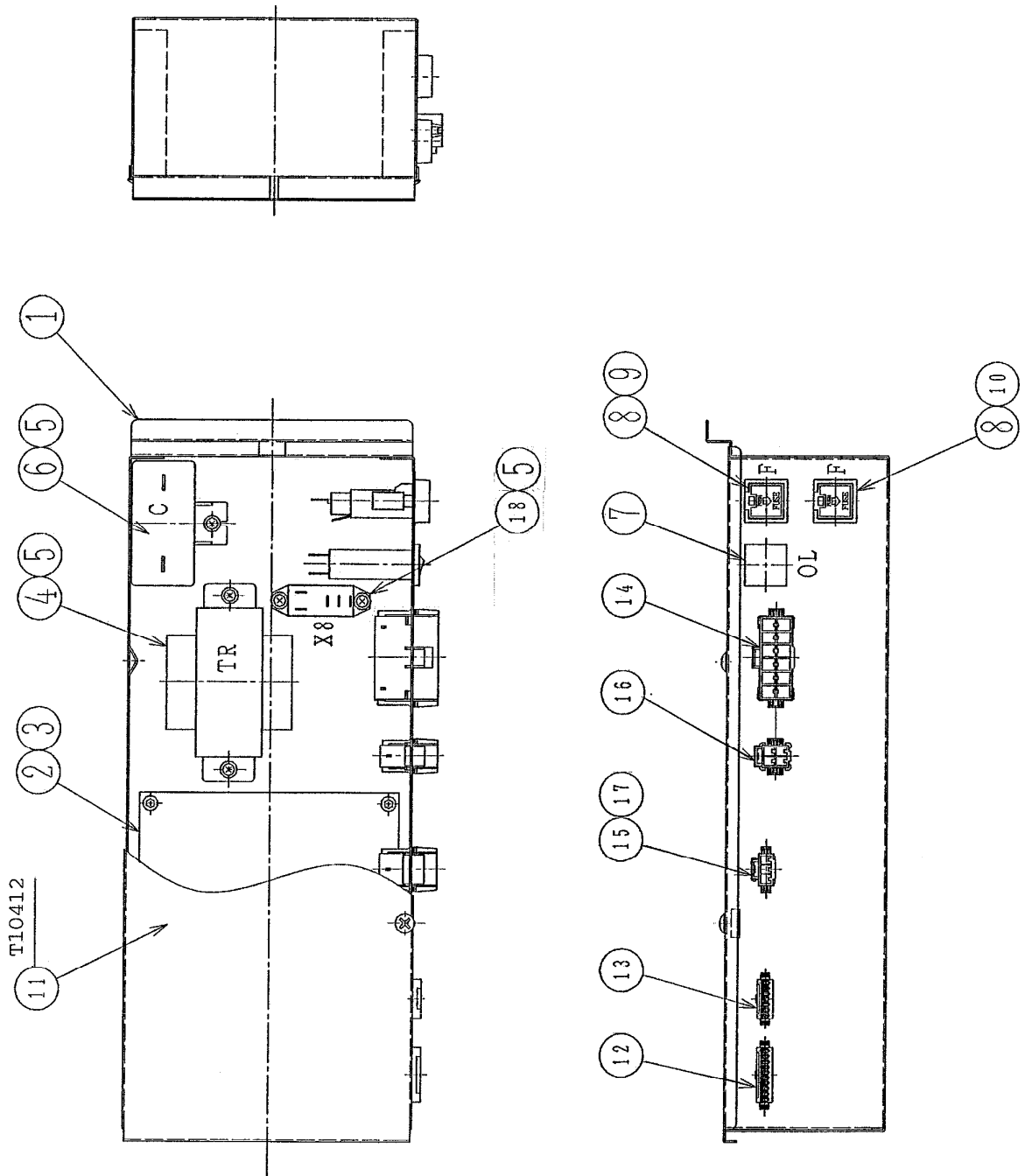

HE

MODEL: DCM-120FE		TITLE: E. CONTROL BOX ASSY					
INDEX NO.	DESCRIPTION	MATERIAL OR MODEL NUMBER	PART NUMBER	REQ'D NUMBER			
				A-1 B-1 B-2	B-3		
1	CONTROL BOX	G.S	230792-01	1	1		
2	CONTROLLER BOARD	H2AE001C02	455655-02	x1			
		H2AE001C03	461556-01	o1	1		
3	BOARD SUPPORT	KGLS-6S	414929-01	4	4		
4	TRANSFORMER	TR7990, AC100V	450438-01	1	1		
5	TAPPING SCREW	3x8	431415-01	3	3		
6	CAPACITOR	CME25B146DY	450456-01	1	1		
7	OVERLOAD	W28XQ1A-3, 3A	440972-02	1	1		
8	FUSE HOLDER	F-150-BB, 250V 10A	438024-01	2	2		
9	FUSE	FGB0, 10A	406519-08	1	1		
10	FUSE	FGB0, 3A	406519-04	1	1		
11	COVER - CONTROL BOX	G.S	343420-01	1	1		
12	RECEPTACLE HOUSING	SMP-10V-NC	433787-02	1	1		
13	RECEPTACLE HOUSING	SMP-07V-NC	433787-11	1	1		
14	RECEPTACLE HOUSING	VLR-12V	454247-06	1	1		
15	-	-	-	-			
16	RECEPTACLE HOUSING	VLR-04V	454247-04	1	1		
17	RECEPTACLE HOUSING	VLR-06V	454247-05	1	1		
18	POWER RELAY	G2R-1-T, AC100V	430173-01	1	1		

HE
DCM-120FE

F. APRON PANEL ASSY

(A-1)(B-1)(B-2)(B-3)
(J-4)(J-5)(K-1)(A-0)
(J-0)(J-1)(J-2)(J-3)
(H-1)(H-2)

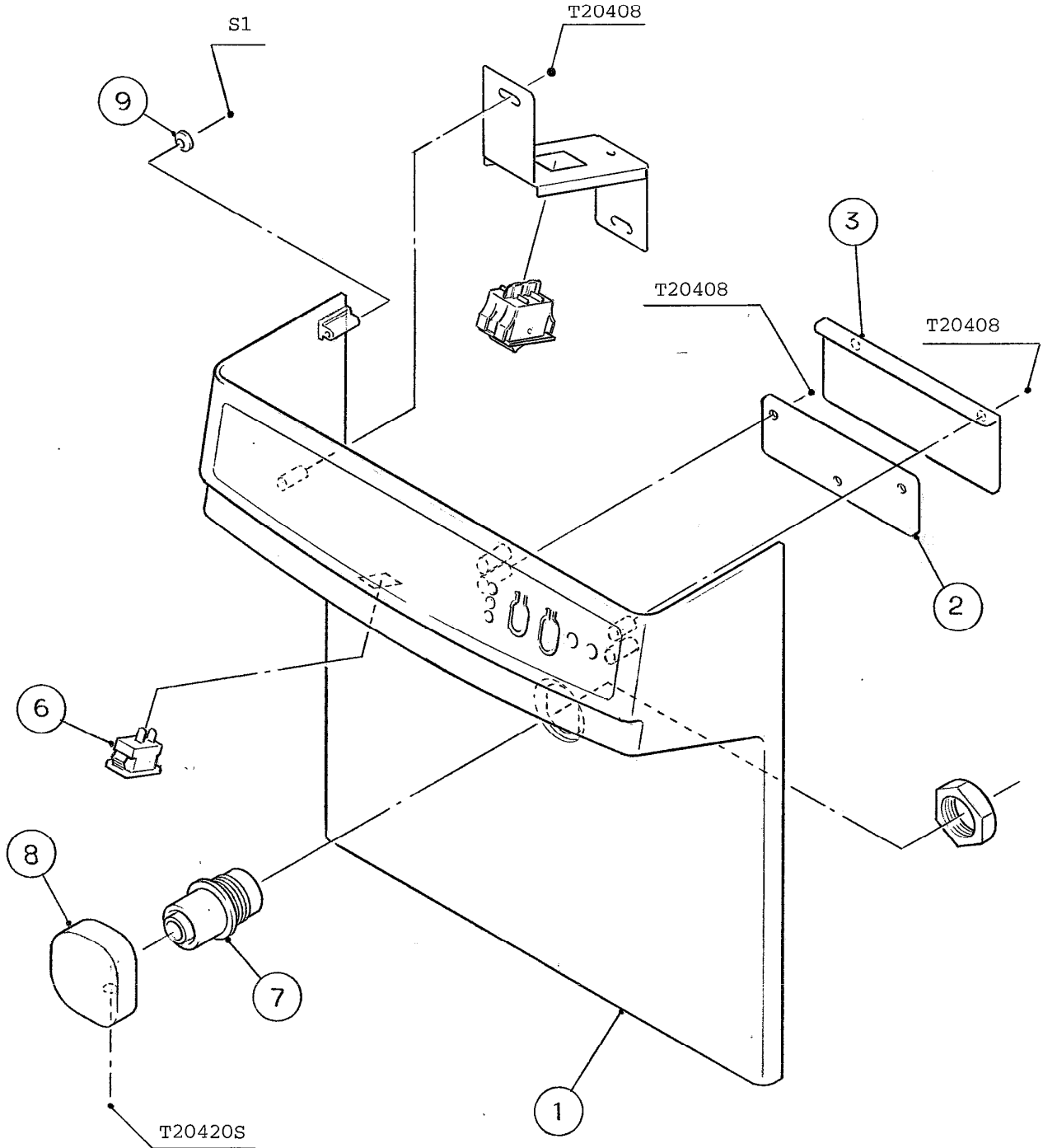

FASTENER
S1 - FLAT HEAD TAPPING SCREW,
M4x8

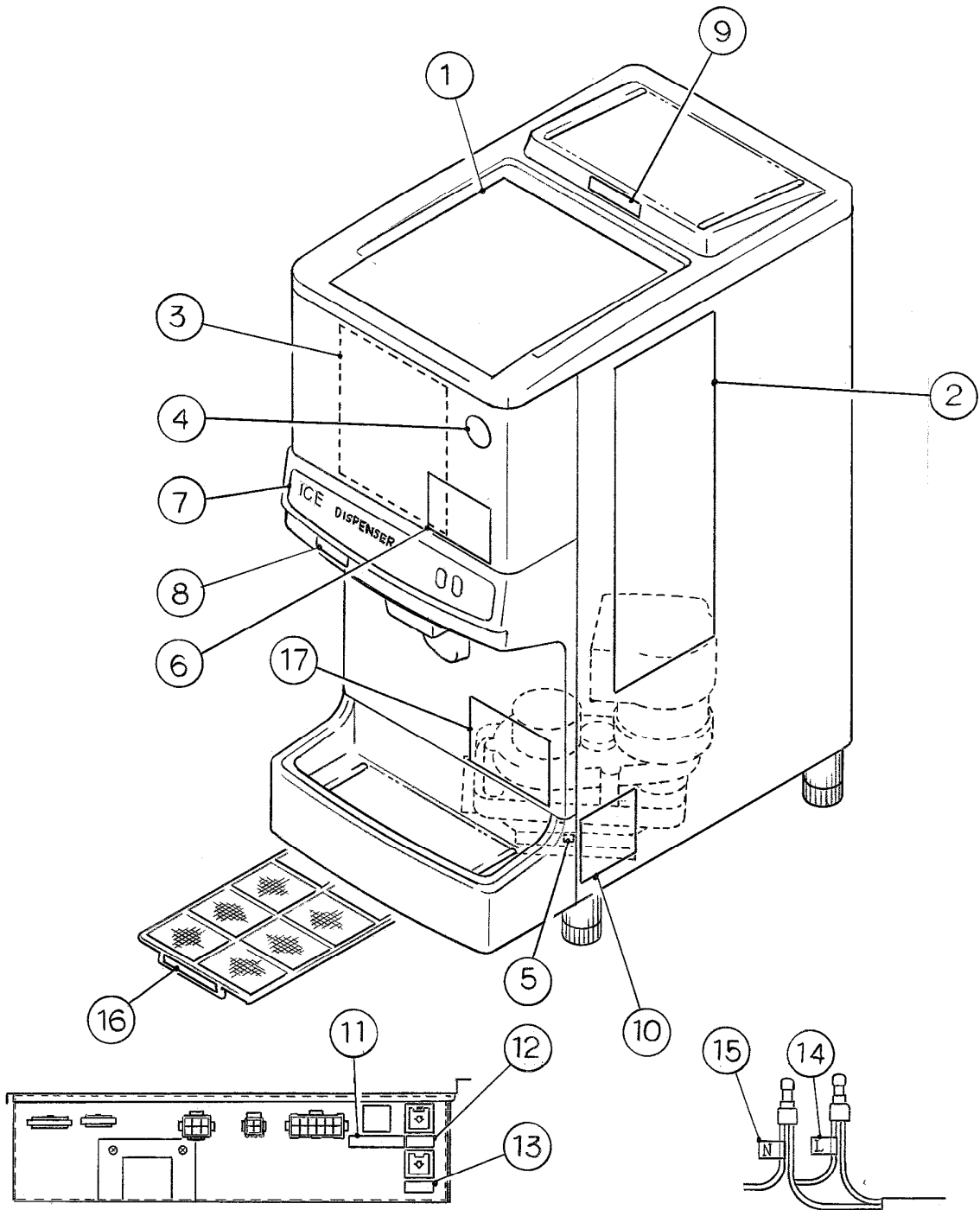

CONTROL BOX

TERMINAL

HE
DCM-120FE

G. LABEL LOCATION

(B-2) (B-3)
(A-0) (A-1) (B-1)
(J-4) (J-5) (K-1)
(J-3) (J-2) (J-1)

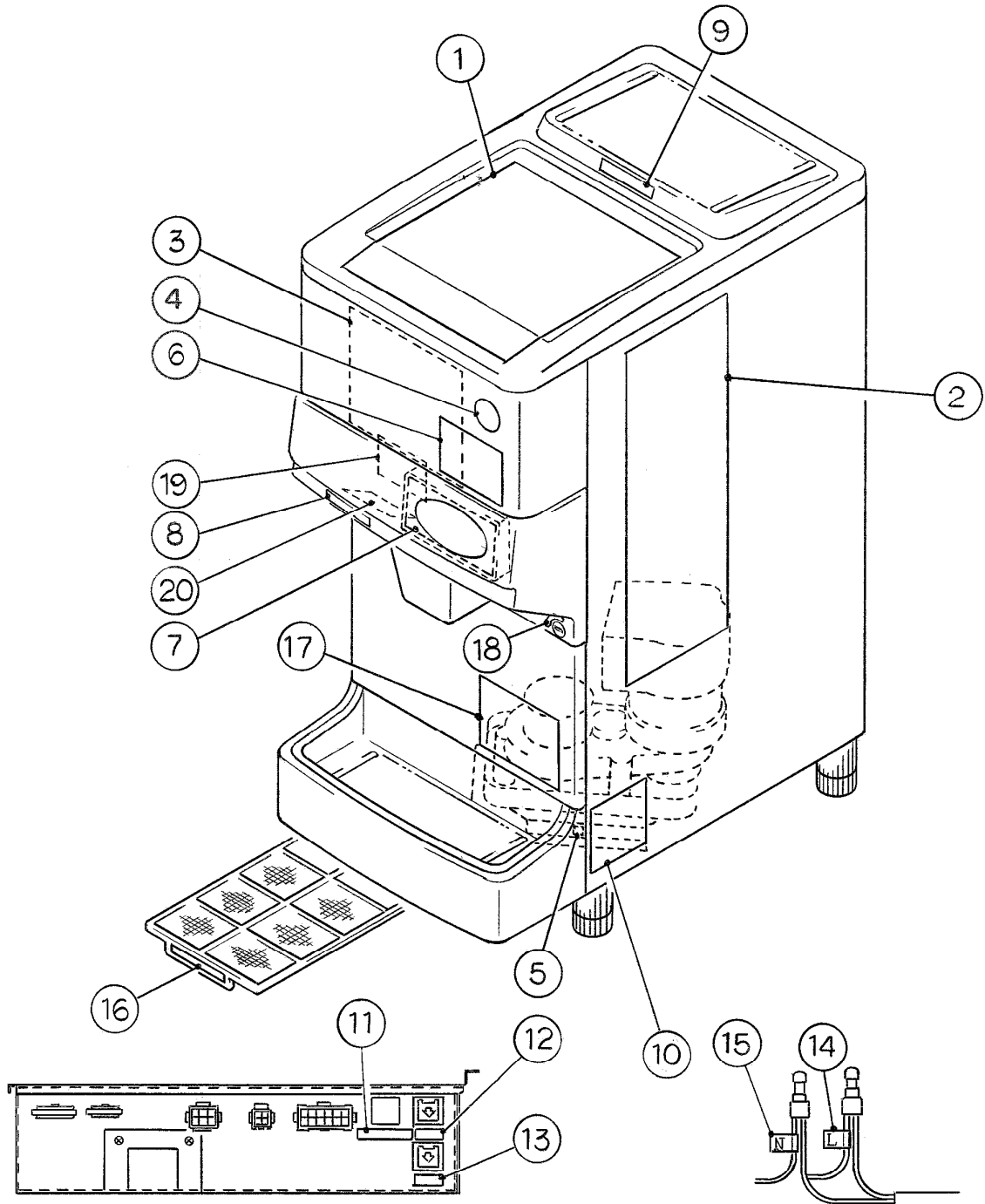

CONTROL BOX

TERMINAL

HE

MODEL: DCM-120FE		TITLE: G. LABEL LOCATION					
INDEX NO.	DESCRIPTION	MATERIAL OR MODEL NUMBER	PART NUMBER	REQ'D NUMBER			
				H-1	H-2 J-0	J-1	J-2
1	INSTRUCTION SHEET	PAPER	229882-01	1	1	-	
		PAPER	231040-01			1	1
2	INSTRUCTION LABEL	PES FILM	229883-01	1	1	-	
		PES FILM	231039-01			1	1
3	WIRING LABEL	PVC FILM	342346-01	1	1	1	1
4	LABEL - PENGUIN	PES FILM	451262-01	1	x 1		
		PESFILM	454387-02		o 1	1	1
5	LABEL - EARTH	PES FILM	450452-02	1	1	1	1
6	LABEL - EFFICIENT USE	PETP FILM	425319-01	1	1	1	1
7	OPERATION LABEL	PES FILM	342347-01	1	1	-	
		PES FILM	343631-01			1	1
8	LABEL - POWER SUPPLY	PES FILM	455726-01	1	1	-	
		PES FILM	456670-01			1	1
9	LABEL - FAN MOTOR	PETP FILM	425320-01	1	1	1	1
10	NAMEPLATE	PES FILM	N/A	1	1	1	1
11	LABEL - RESET	PETP FILM	425326-01	1	1	1	1
12	LABEL - FUSE (10A)	PES FILM	455750-01	1	1	1	1
13	LABEL - FUSE (3A)	PES FILM	455750-02	1	1	1	1
14	LABEL - TERMINAL (L)	PVC FILM	452379-01	1	1	1	1
15	LABEL - TERMINAL (N)	PVC FILM	452379-02	1	1	1	1
16	LABEL - AIR FILTER	PES FILM	452799-01	1	1	1	1
17	LABEL - DRAIN	PES FILM	455729-01	1	1	1	1
18	LABEL - OPEN & SHUT	PES FILM	456669-01			2	2
19	LABEL - UNPLUG	PES FILM	456751-01			1	1
20	CONTROL LABEL	PES FILM	456671-01			1	1

HE
DCM-120FE

H. SHUTTER ASSY

(A-0)(A-1)(B-1)(B-2)
(J-4)(J-5)(K-1)
(J-3)(J-2)(J-1)
(H-1)(H-2)(J-0)

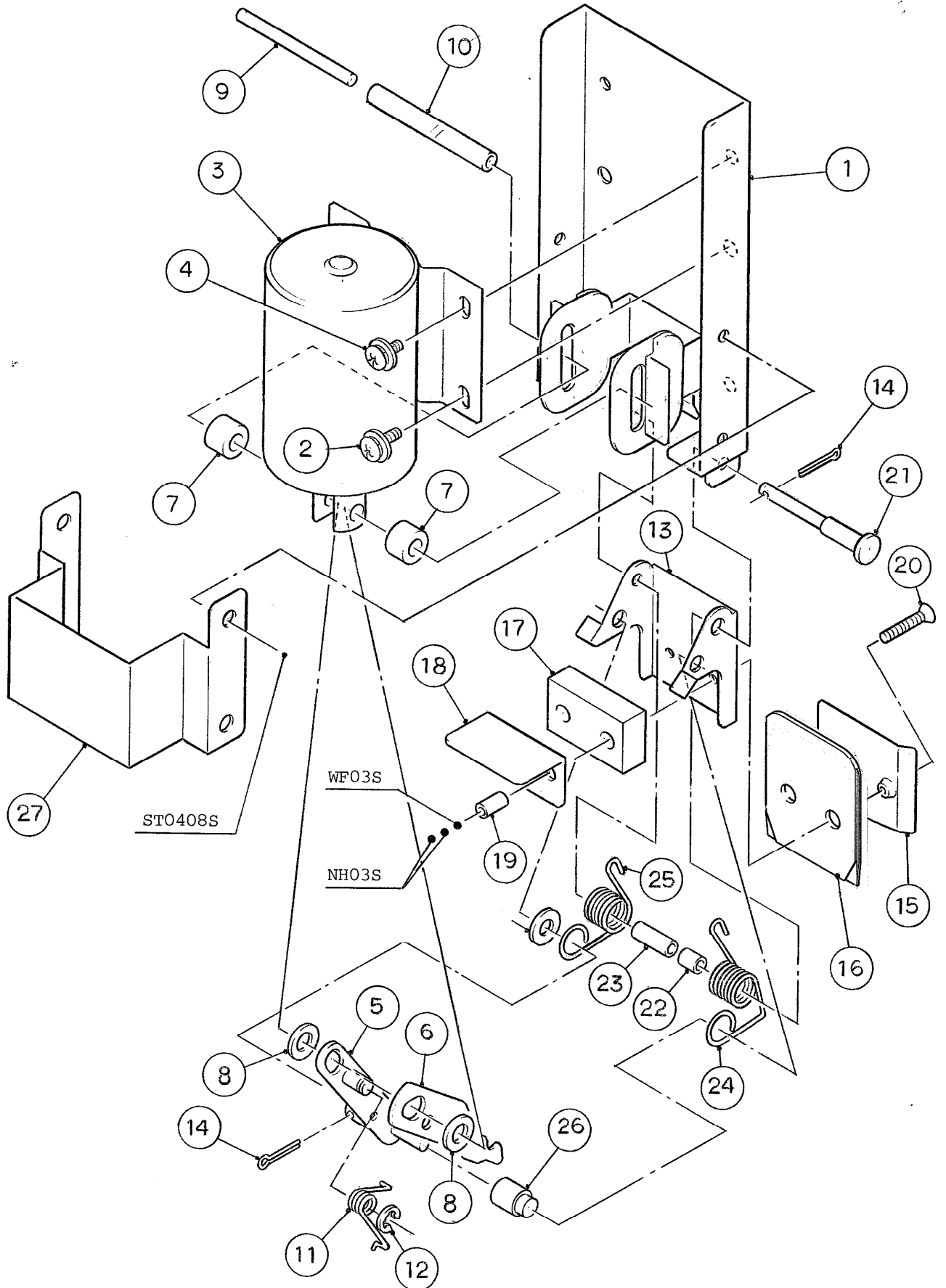

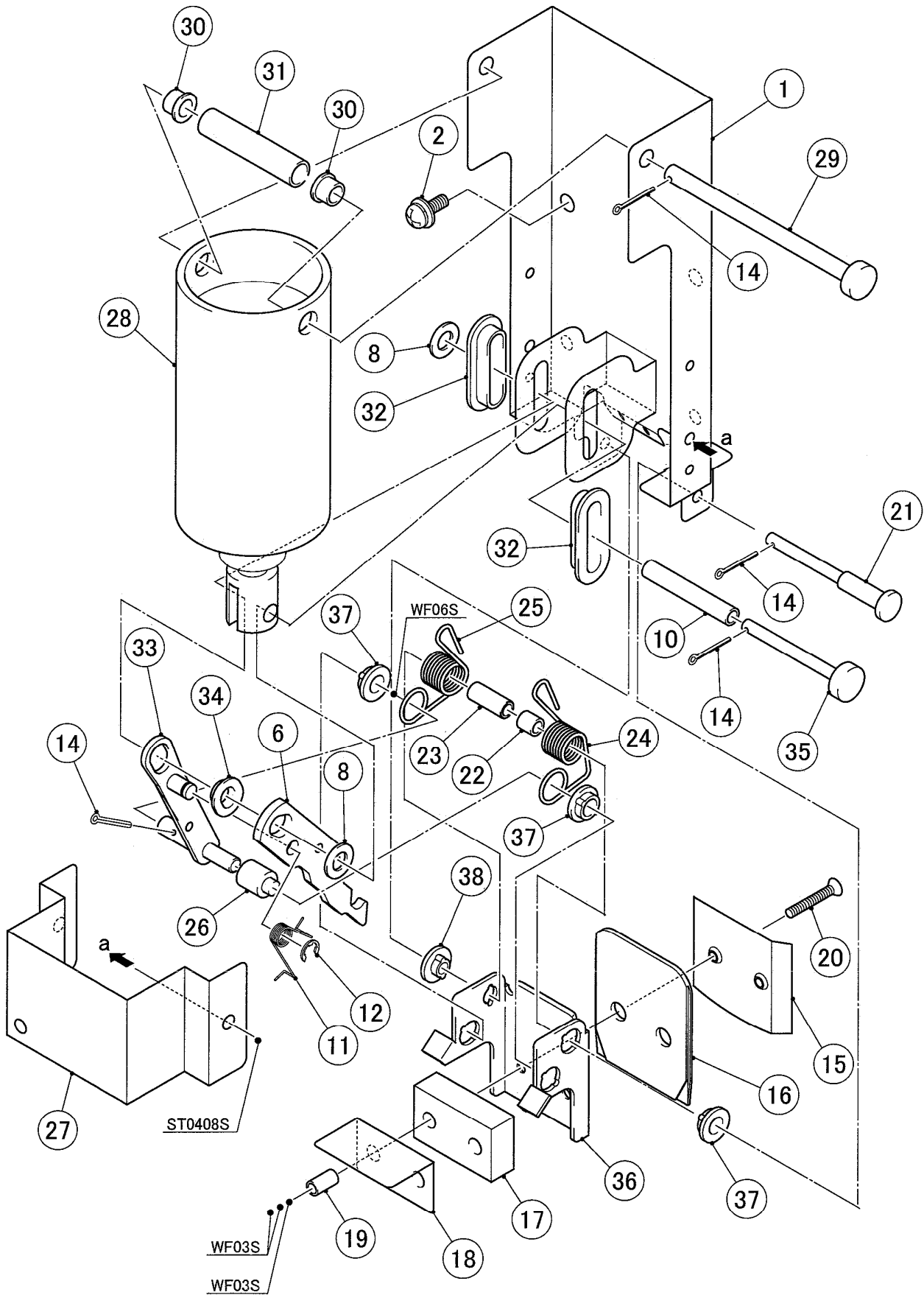

HE

MODEL: DCM-120FE TITLE: H. SHUTTER ASSY							
INDEX NO.	DESCRIPTION	MATERIAL OR MODEL NUMBER	PART NUMBER	REQ'D NUMBER			
				H-1	H-2 J-0	J-1	J-2
1	BRACKET - SOLENOID	S.S	341414G01	1	1	1	1
2	SCREW	S.S, 4x12	434438-02	4	4	4	4
3	SOLENOID	SSD-18	454755-01	1	1	1	1
4	SCREW	S.S, 4x8	434838-01	2	2	2	2
5	SHAFT	S.S	441645G01	1	1	1	1
6	HOOK - SHUTTER	S.S	438406-02	1	1	1	1
7	COLLAR (B)	ABS	432524-02	2	2	2	2
8	SPACER	ABS	454943-01	2	2	2	2
9	SHAFT (D)	S.S	452491-02	1	1	1	1
10	TUBE	L=52	451284-04	1	1	1	1
11	SPRING	S.S	411532-01	1	1	1	1
12	"E" RING	S.S, 4	721S-0004	1	1	1	1
13	STOPPER - SHUTTER	S.S	451280-01	1	1	1	1
14	SPLIT PIN	S.S, 1.6x12	711SP1612	2	2	2	2
15	PLATE (A1) - SHUTTER	S.S	414756-01	1	1	1	1
16	PLATE (B) - SHUTTER	EPDM	423948-01	1	1	1	1
17	PLATE (C) - SHUTTER	SY. R FOAM	419150-01	1	1	1	1
18	PLATE (D) - SHUTTER	S.S	419151-01	1	1	1	1
19	COLLAR (C) - SHUTTER	S.S	411539-03	2	2	2	2
20	SCREW	3x20	441581-01	2	2	2	2
21	SHAFT (B)	S.S	454941-01	1	1	1	1
22	TUBE	L=6	451284-05	1	1	1	1
23	COLLAR	S.S	454942-01	1	1	1	1
24	SPRING (RIGHT)	S.S	452502-01	1	1	1	1
25	SPRING (LEFT)	S.S	452503-01	1	1	1	1
26	SHAFT (B2) - SHUTTER	S.S	432520-02	1	1	1	1
27	COVER	S.S	341411-01	1	1	1	1

HE

MODEL: DCM-120FE TITLE: H. SHUTTER ASSY							
INDEX NO.	DESCRIPTION	MATERIAL OR MODEL NUMBER	PART NUMBER	REQ'D NUMBER			
				J-3	J-4	J-5	K-1 A-0
1	BRACKET - SOLENOID	S.S	341414G01	1	1	1	1
2	SCREW	S.S, 4x12	434438-02	4	4	4	4
3	SOLENOID	SSD-18	454755-01	1	1	1	1
4	SCREW	S.S, 4x8	434838-01	2	2	2	2
5	SHAFT	S.S	441645G01	1	1	1	1
6	HOOK - SHUTTER	S.S	438406-02	1	1	1	1
7	COLLAR (B)	ABS	432524-02	2	2	2	2
8	SPACER	ABS	454943-01	2	2	2	2
9	SHAFT (D)	S.S	452491-02	1	1	1	1
10	TUBE	L=52	451284-04	1	1	1	1
11	SPRING	S.S	411532-01	1	1	1	1
12	"E" RING	S.S, 4	721S-0004	1	1	1	1
13	STOPPER - SHUTTER	S.S	451280-01	1	1	1	1
14	SPLIT PIN	S.S, 1.6x12	711SP1612	2	2	2	2
15	PLATE (A1) - SHUTTER	S.S	414756-01	1	1	1	1
16	PLATE (B) - SHUTTER	EPDM	423948-01	1	1	1	1
17	PLATE (C) - SHUTTER	SY. R FOAM	419150-01	1	1	1	1
18	PLATE (D) - SHUTTER	S.S	419151-01	1	1	1	1
19	COLLAR (C) - SHUTTER	S.S	411539-03	2	2	2	2
20	SCREW	3x20	441581-01	2	2	2	2
21	SHAFT (B)	S.S	454941-01	1	1	1	1
22	TUBE	L=6	451284-05	1	1	1	1
23	COLLAR	S.S	454942-01	1	1	1	1
24	SPRING (RIGHT)	S.S	452502-01	1	1	1	1
25	SPRING (LEFT)	S.S	452503-01	1	1	1	1
26	SHAFT (B2) - SHUTTER	S.S	432520-02	1	1	1	1
27	COVER	S.S	341411-01	1	1	1	1

HE

MODEL: DCM-120FE TITLE: H. SHUTTER ASSY							
INDEX NO.	DESCRIPTION	MATERIAL OR MODEL NUMBER	PART NUMBER	REQ'D NUMBER			
				A-1 B-1 B-2	B-3		
1	BRACKET - SOLENOID	S.S	341414G01	1	-		
			351479G01		1		
2	SCREW	S.S, 4x12	434438-02	4	4		
3	SOLENOID	SSD-18	454755-01	1	-		
4	SCREW	S.S, 4x8	434838-01	2	-		
5	SHAFT	S.S	441645G01	1	-		
6	HOOK - SHUTTER	S.S	438406-02	1	1		
7	COLLAR (B)	ABS	432524-02	2	-		
8	SPACER	ABS	454943-01	2	2		
9	SHAFT (D)	S.S	452491-02	1	-		
10	TUBE	L=52	451284-04	1	-		
			451284-06		1		
11	SPRING	S.S	411532-01	1	1		
12	"E" RING	S.S, 4	721S-0004	1	1		
13	STOPPER - SHUTTER	S.S	451280-01	1	-		
14	SPLIT PIN	S.S, 1.6x12	711SP1612	2	4		
15	PLATE (A1) - SHUTTER	S.S	414756-01	1	1		
16	PLATE (B) - SHUTTER	EPDM	423948-01	1	1		
17	PLATE (C) - SHUTTER	SY. R FOAM	419150-01	1	1		
18	PLATE (D) - SHUTTER	S.S	419151-01	1	1		
19	COLLAR (C) - SHUTTER	S.S	411539-03	2	2		
20	SCREW	3x20	441581-01	2	2		
21	SHAFT (B)	S.S	454941-01	1	-		
			462561-01		1		
22	TUBE	L=6	451284-05	1	1		
23	COLLAR	S.S	454942-01	1	1		
24	SPRING (RIGHT)	S.S	452502-01	1	1		
25	SPRING (LEFT)	S.S	452503-01	1	1		
26	SHAFT (B2) - SHUTTER	S.S	432520-02	1	1		
27	COVER	S.S	341411-01	1	1		
28	SOLENOID	SSD-18T	462557-01		1		
29	SHAFT - SOLENOID		462557-01		1		

HE

MODEL: DCM-120FE								TITLE: H. SHUTTER ASSY			
INDEX NO.	DESCRIPTION	MATERIAL OR MODEL NUMBER	PART NUMBER	REQ'D NUMBER							
				A-1 B-1 B-2	B-3						
30	BUSH		462558-01		2						
31	COLLAR - SOLENOID		462559-01		1						
32	SPACER (C)		461232-01		2						
33	SHAFT		462262G01		1						
34	SPACER (D)		461233-01		1						
35	SHAFT - PLUNGER		462258-01		1						
36	STOPPER		351480-01		1						
37	SPACER (A)		461230-01		3						
38	SPACER (B)		461231-01		1						

HE
DCM-120FE

J. COVER ASSY - BIN TOP

(A-0) (A-1) (B-1) (B-2) (B-3)
(J-4) (J-5) (K-1)
(J-3) (J-2) (J-1)
(H-1) (H-2) (J-0)

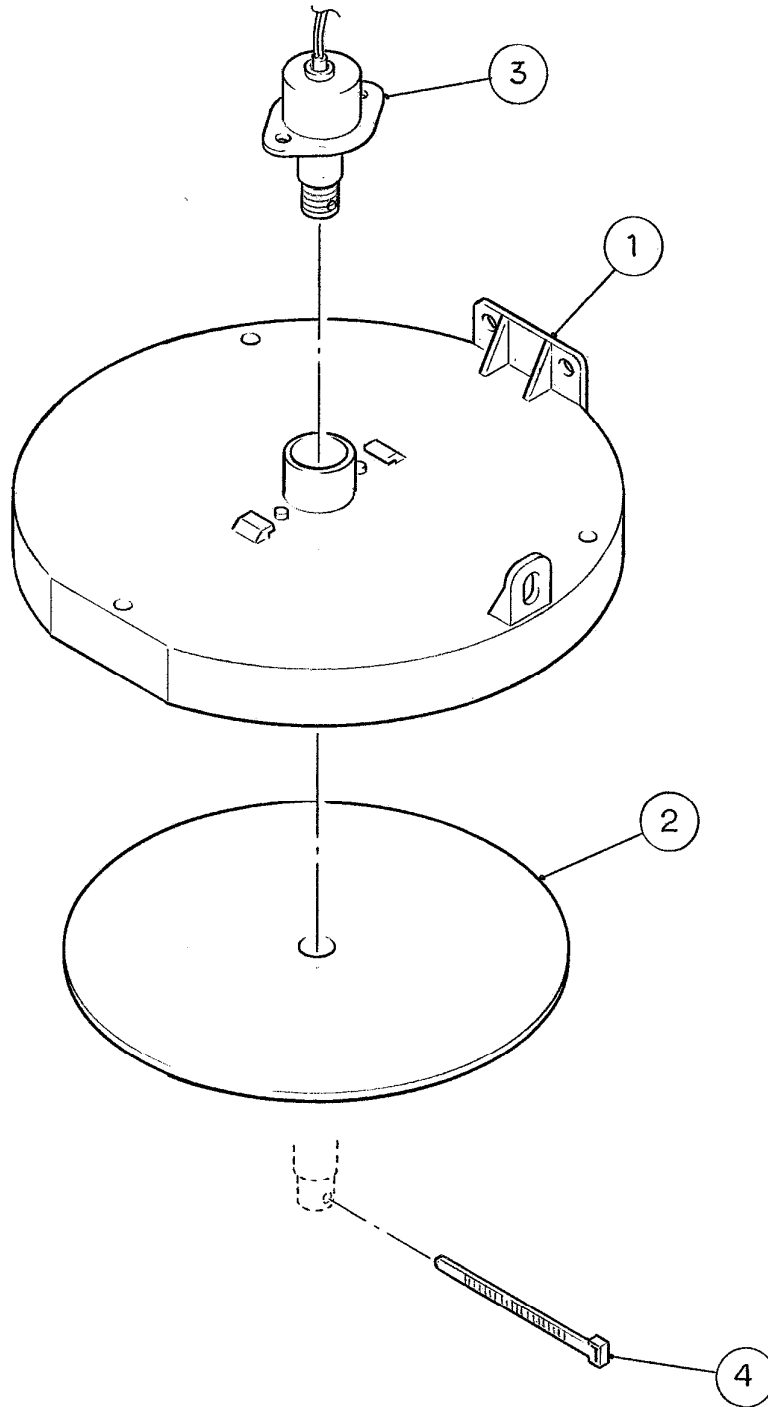

HE

MODEL: DCM-120FE		TITLE: J. COVER ASSY - BIN TOP					
INDEX NO.	DESCRIPTION	MATERIAL OR MODEL NUMBER	PART NUMBER	REQ'D NUMBER			
				H-1	H-2 J-0	J-1	J-2
1	COVER - BIN TOP	ABS	341039G01	1	1	1	1
2	BALANCE PLATE	ABS	454488-01	1	1	1	1
3	BIN CONTROL SWITCH	HS-30	459673-01	1	1	1	1
4	TIE	CV-100	7920-0002	1	1	1	1

HE

MODEL: DCM-120FE TITLE: J. COVER ASSY - BIN TOP							
INDEX NO.	DESCRIPTION	MATERIAL OR MODEL NUMBER	PART NUMBER	REQ'D NUMBER			
				J-3	J-4	J-5	K-1 A-0
1	COVER - BIN TOP	ABS	341039G01	1	1	1	1
2	BALANCE PLATE	ABS	454488-01	1	1	1	1
3	BIN CONTROL SWITCH	HS-30	459673-01	1	1	1	1
4	TIE	CV-100	7920-0002	1	1	1	1

HE

MODEL: DCM-120FE				TITLE: J. COVER ASSY - BIN TOP			
INDEX NO.	DESCRIPTION	MATERIAL OR MODEL NUMBER	PART NUMBER	REQ'D NUMBER			
				A-1 B-1 B-2	B-3		
1	COVER - BIN TOP	ABS	341039G01	1	1		
2	BALANCE PLATE	ABS	454488-01	1	1		
3	BIN CONTROL SWITCH	HS-30	459673-01	1	1		
4	TIE	CV-100	7920-0002	1	1		

HE
DCM-120FE

K. FAN MOTOR ASSY

(A-0)(A-1)(B-1)(B-2)(B-3)
(J-4)(J-5)(K-1)
(J-3)(J-2)(J-1)
(H-1)(H-2)(J-0)

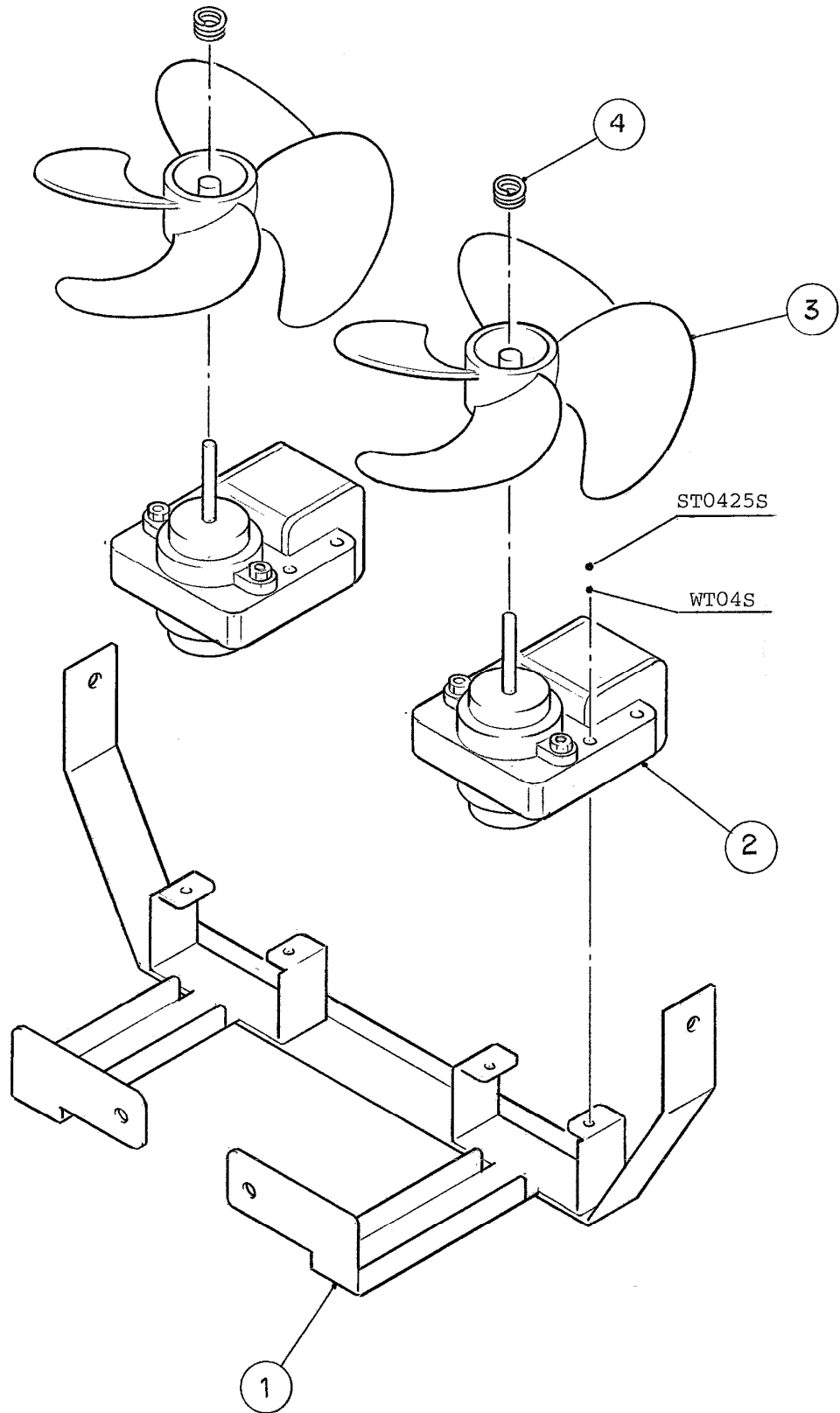

HE

MODEL: DCM-120FE				TITLE: K. FAN MOTOR ASSY			
INDEX NO.	DESCRIPTION	MATERIAL OR MODEL NUMBER	PART NUMBER	REQ'D NUMBER			
				H-1	H-2 J-0	J-1	J-2
1	BRACKET - FAN MOTOR	G.S	341307G01	1	1	1	1
2	FAN MOTOR	J1521	454831-01	2	2	2	2
3	FAN	120 DIA	449877-01	2	2	2	2
4	COIL SPRING	S.S	449877F01	2	2	2	2

HE

MODEL: DCM-120FE TITLE: K. FAN MOTOR ASSY							
INDEX NO.	DESCRIPTION	MATERIAL OR MODEL NUMBER	PART NUMBER	REQ'D NUMBER			
				J-3	J-4	J-5	K-1 A-0
1	BRACKET - FAN MOTOR	G.S	341307G01	1	1	1	1
2	FAN MOTOR	J1521	454831-01	2	2	2	2
3	FAN	120 DIA	449877-01	2	2	2	2
4	COIL SPRING	S.S	449877F01	2	2	2	2

HE

MODEL: DCM-120FE		TITLE: K. FAN MOTOR ASSY					
INDEX NO.	DESCRIPTION	MATERIAL OR MODEL NUMBER	PART NUMBER	REQ'D NUMBER			
				A-1 B-1 B-2	B-3		
1	BRACKET - FAN MOTOR	G.S	341307G01	1	1		
2	FAN MOTOR	J1521	454831-01	2	2		
3	FAN	120 DIA	449877-01	2	2		
4	COIL SPRING	S.S	449877F01	2	2		

HE
DCM-120FE

L. ACCESSORIES

(A-0) (A-1) (B-1) (B-2) (B-3)
(J-4) (J-5) (K-1)
(J-3) (J-2) (J-1)
(H-1) (H-2) (J-0)

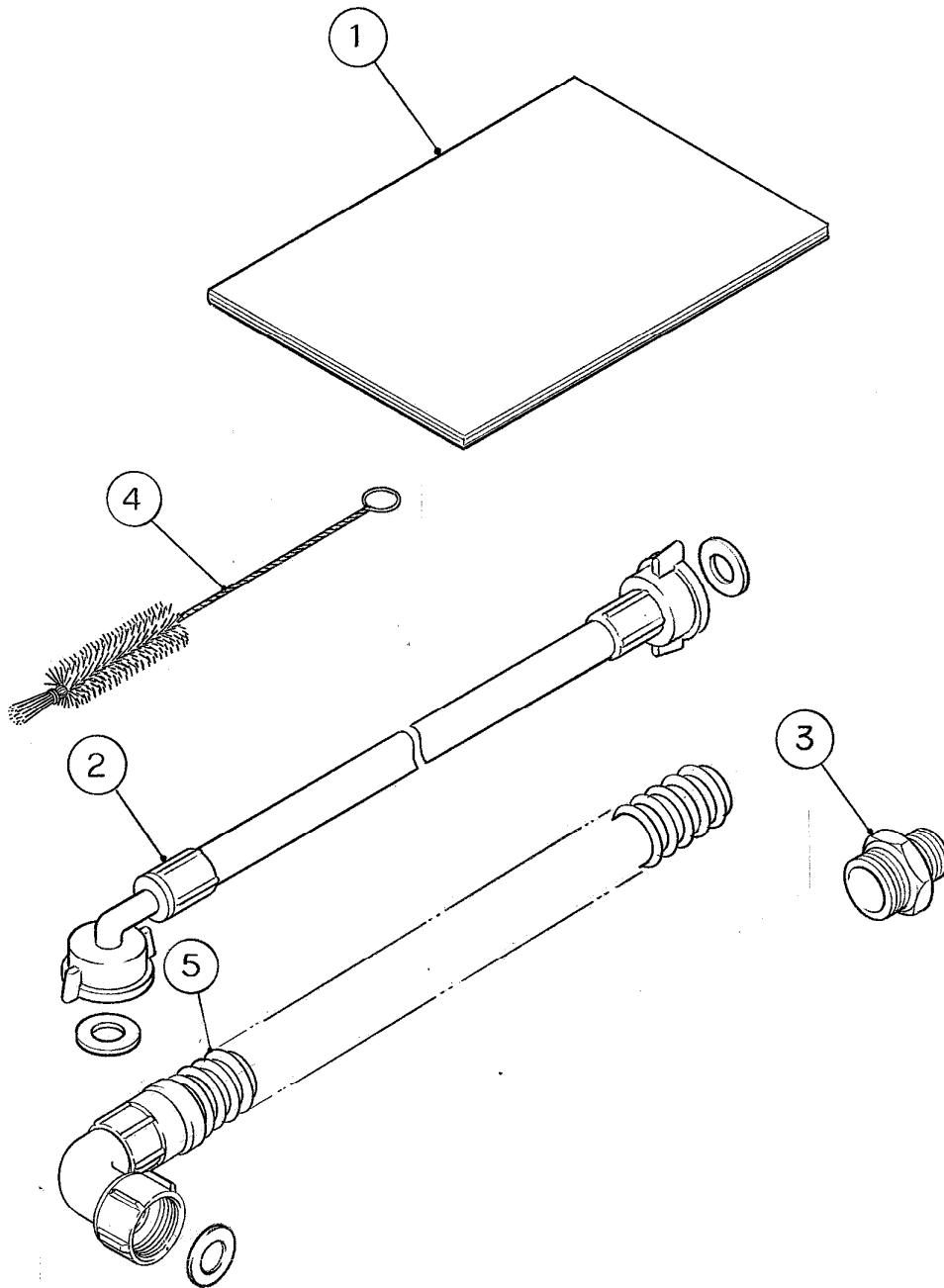

HE

MODEL: DCM-120FE				TITLE: L. ACCESSORIES			
INDEX NO.	DESCRIPTION	MATERIAL OR MODEL NUMBER	PART NUMBER	REQ'D NUMBER			
				H-1	H-2 J-0	J-1	J-2
1	INSTRUCTION MANUAL	PAPER	9124CG21A	1	1	1	1
2	INLET HOSE	HOSH01	450722-01	2	2	2	2
3	ADAPTER / NIPPLE	BRASS	450724-01	1	1	1	1

HE

MODEL: DCM-120FE				TITLE: L. ACCESSORIES			
INDEX NO.	DESCRIPTION	MATERIAL OR MODEL NUMBER	PART NUMBER	REQ'D NUMBER			
				J-3	J-4	J-5	K-1 A-0
1	INSTRUCTION MANUAL	PAPER	9124CG21A	1	1	1	1
2	INLET HOSE	HOSH01	450722-01	2	2	2	2
3	ADAPTER / NIPPLE	BRASS	450724-01	1	1	1	1
4	BRUSH	300919A	457264-01			1	1
5	OUTLET HOSE	62506	452365-01				1

HE

MODEL: DCM-120FE		TITLE: L. ACCESSORIES					
INDEX NO.	DESCRIPTION	MATERIAL OR MODEL NUMBER	PART NUMBER	REQ'D NUMBER			
				A-1	B-1	B-2	B-3
1	INSTRUCTION MANUAL	PAPER	9124CG21A	1	1		
2	INLET HOSE	HOSH01	450722-01	2	2		
3	ADAPTER / NIPPLE	BRASS	450724-01	1	1		
4	BRUSH	300919A	457264-01	1	1		
5	OUTLET HOSE	62506	452365-01	1	1		

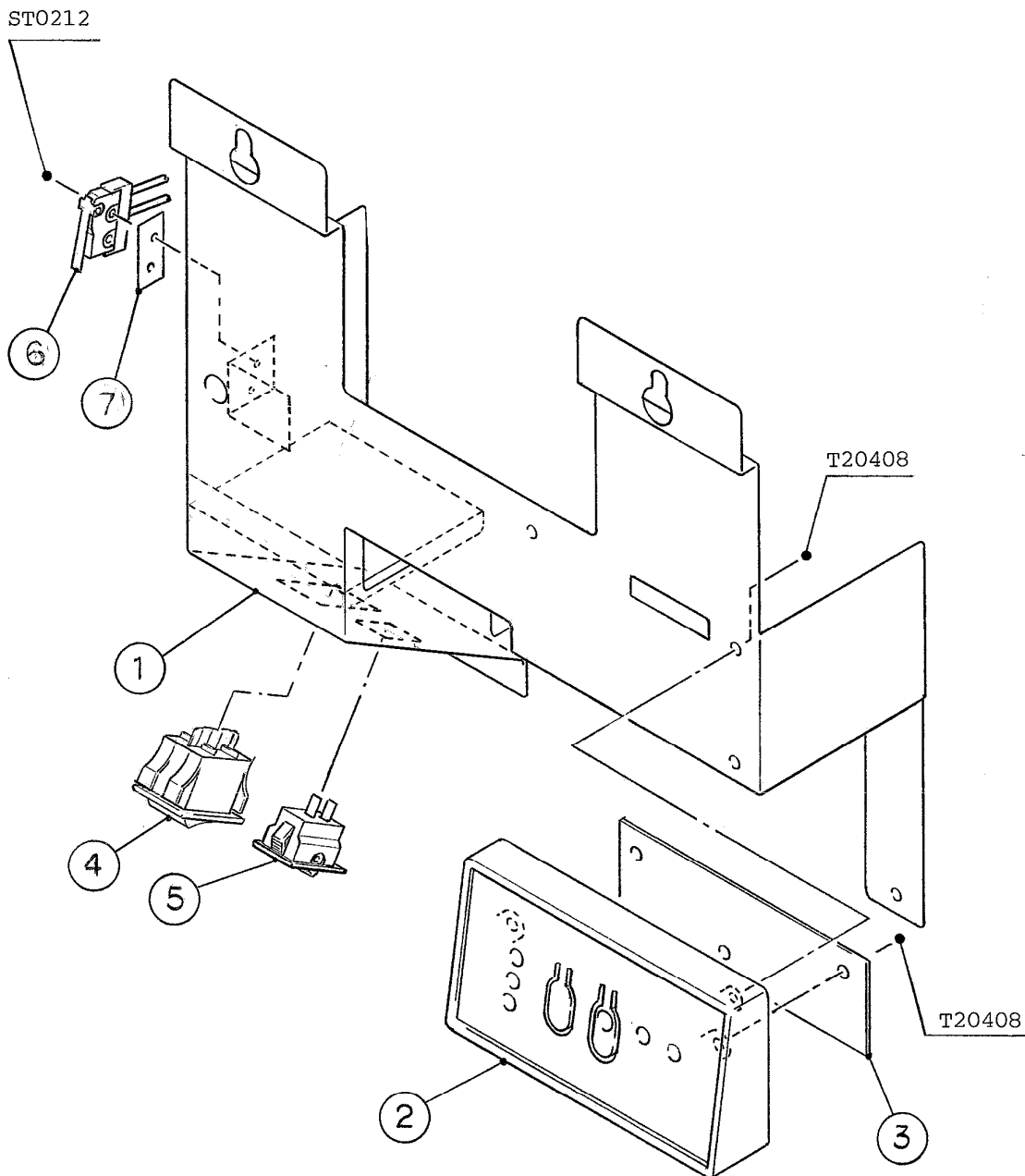

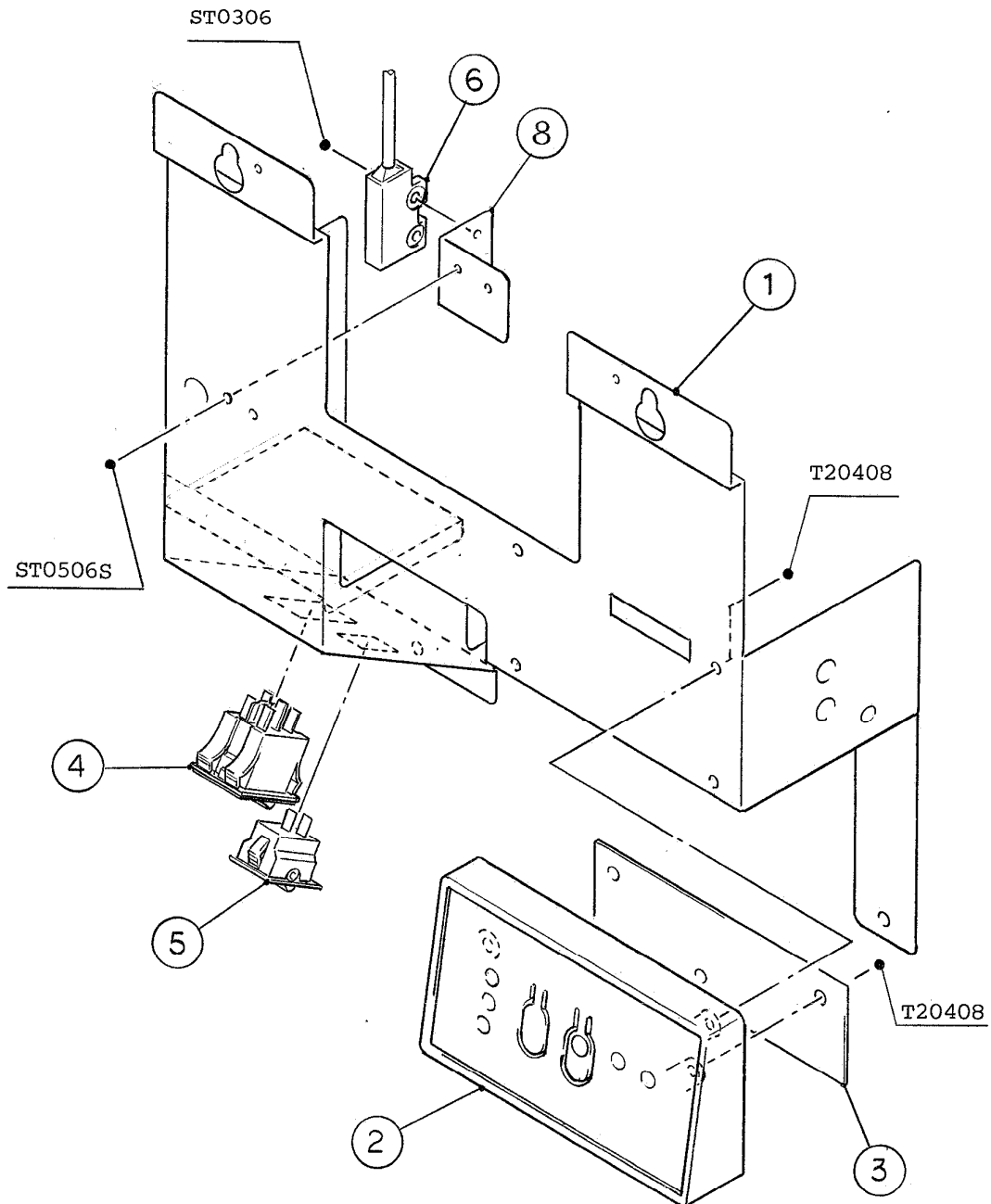

HE

MODEL: DCM-120FE TITLE: M. BRACKET (B) ASSY							
INDEX NO.	DESCRIPTION	MATERIAL OR MODEL NUMBER	PART NUMBER	REQ'D NUMBER			
				H-1	H-2 J-0	J-1	J-2
1	BRACKET (B)		343424G01		o 1	1	1
2	HOLDER	ABS	230749-01		o 2	2	2
3	OPERATION BOARD	H2AE004C01	455654-01		o 1	1	1
4	ROCKER SWITCH (A)	JW-L11PKK	450440-01		o 1	1	1
5	ROCKER SWITCH (B)	DS-850K-F-00	433268-01		o 1	1	1
6	MICROSWITCH	D2SW-3L1-3M	450826-01		o 1	1	1
7	SPACER	PVC	456495-01		o 1	1	1

