

NO. U2GJ-775

ISSUED: SEP. 16.1988

REVISED : SEP27.1991

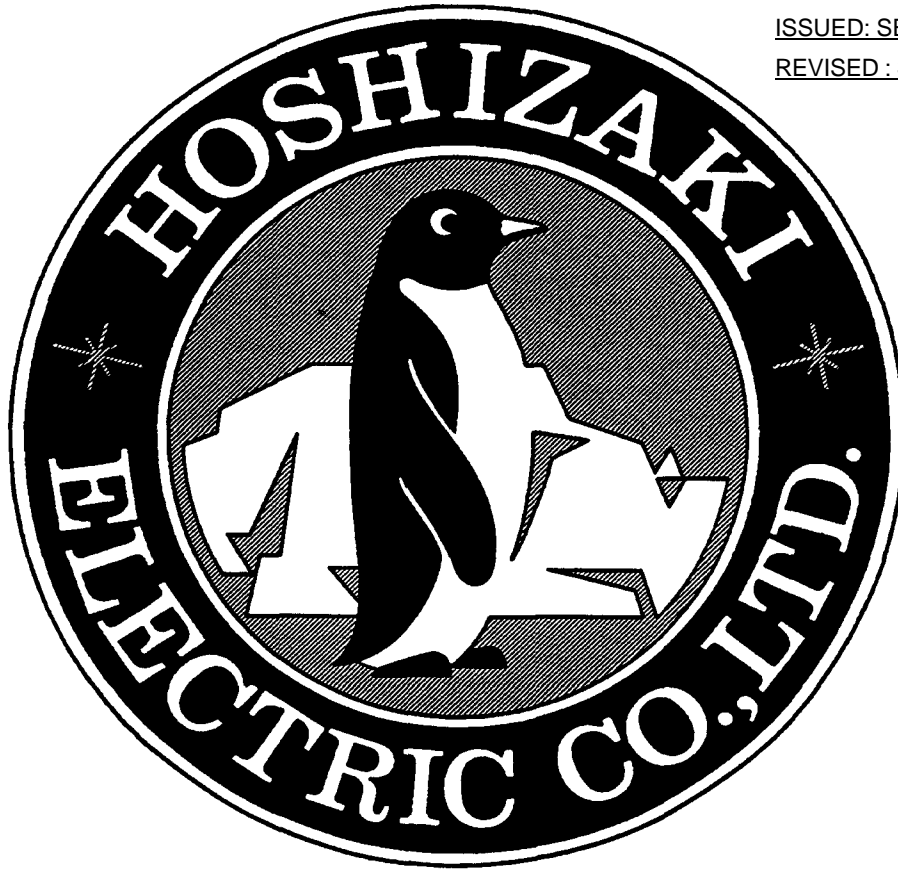

HOSHIZAKI

CUBELET ICE DISPENSER

MODEL DCM-240BAA

PARTS LIST

J-1 SEP. 1988
K-0 DEC. 1989
K-1 FEB. 1990
A-0 DEC. 1990

FINAL

MODEL		TITLE						
INDEX NO.	DESCRIPTION	MATERIAL OR MODEL NUMBER	PART NUMBER	REQ'D NUMBER				
				J-1	K-0	K-1	A-0	
B	EVAPORATOR ASSEMBLY	-	211325A05	1	1	-		
			211325A06			1	1	
C	REFRIGERATION UNIT	-	103062A02	1	1	1	1	
D	WATER CIRCUIT ASSEMBLY	-	103117A05	1	1	1	1	
E	CONTROL BOX (A) ASSEMBLY	-	322857A01	1	1	1	1	
F	FRONT PANEL (MIDDLE) ASSEMBLY	-	315702A02	1	1	1	1	
G	FRONT PANEL (LOWER) ASSEMBLY	-	207760A05	1	1	1	1	
H	LABEL LOCATION	-	322863A01	1	1	-		
			322863A02			1	1	
J	CONTROL BOX (B) ASSEMBLY	-	315699A02	1	1	1	1	
1	Frame	G.S	103058G01	1	1	1	1	
2	Bracket - Gear Motor	G.S	423939-01	1	1	1	1	
3	Drip Pan	S.S	425205-01	1	1	1	1	
4	Power Supply Cord	KP-30B	421824-01	1	1	1	1	
5	Bushing	SB-1500-21	420470-06	2	2	2	2	
6	Cabinet	S.S	424987G10	1	1	1	1	
7	Col la r	S.S	4H0171-01	1	1	1	1	
8	Drain Pan	ABS	318857G02	1	1	1	1	
9	Front Panel (Upper)	S.S	320074G02	1	1	1	1	
10	Top Panel	G.S	103047G03	X				
	Top Panel (A)	G.S	104679-01	①	1	1	1	
11	Louver	ABS	101812-01	1	1	1	1	
12	Grille	ABS	102936-02	1	1	1	1	
13	Adjustable Leg	222-P-16B	417192-01	4	4	4	4	
14	Air FILTER	ABS	3H0323G01	1	1	1	1	
15	Barrier	G.S	425637-01	1	1	1	1	
16	Bracket	S.S	424988-02	1	1	1	1	
17	Sound Damper	EPDM	426213-01	1	1	1	1	
18	Barrier	G.S	425092G01	1	1	1	1	
19	Barrier	G.S	425093-01	1	1	1	1	
20	Barrier	G.S	425097-01	1	1	1	1	
21	Washer	PVC	425206-01	3	3	3	3	
22	Thumbscrew	S.S	425221-01	1	1	1	1	
23	Thumbscrew	S.S, ABS	415949G04	2	2	2	2	
24	Bushing	SR-7K-2	420472-02	1	1	1	1	
25	Cover - Chassis	G.S	436917-01	1	1	1	1	

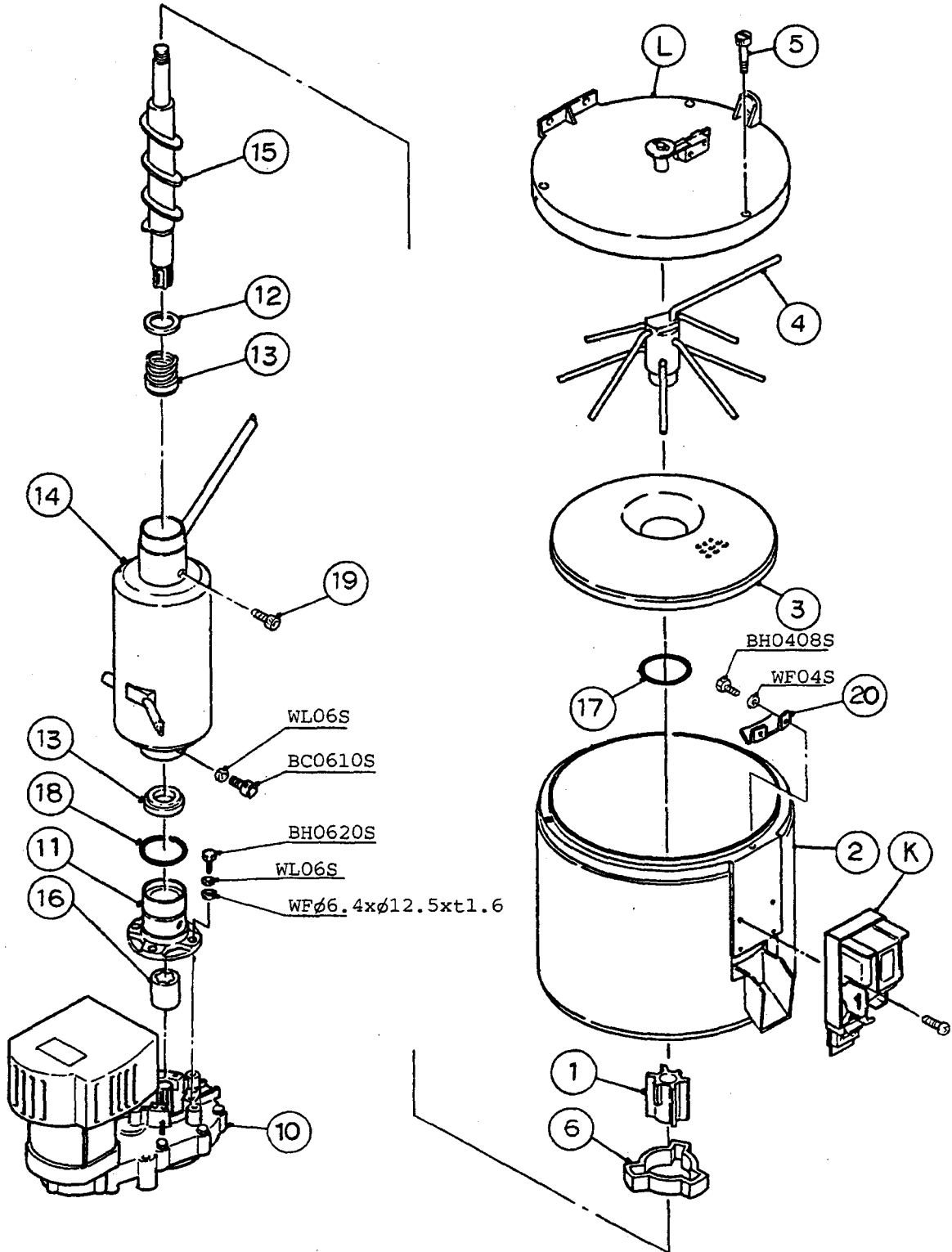

MODEL		TITLE						
DCM-240BAA		B. EVAPORATOR ASSEMBLY						
INDEX NO.	DESCRIPTION	MATERIAL OR MODEL NUMBER	PART NUMBER	REQ'D NUMBER				
				J-1	K-0	K-1	A-0	
K	SHUTTER ASSEMBLY	-	211265A04	1	1	-		
		-	211265A06			1	1	
L	COVER ASSEMBLY - BIN TOP	-	207757A01	1	1	1	1	
1	Extruding Head	S.S	311407G02	1	1	1	1	
2	Storage Bin	-	211630G01	1	1	1	1	
3	Drip Ring	S.S	207754-01	1	1	1	1	
4	Agitator	S.S	314997G01	1	1	1	1	
5	Thumbscrew	S.S, ABS	430825G01	3	3	3	3	
6	Cover - Upper, Evaporator	PE Foam	413446-01	1	1	1	1	
7	-	-	-	-				
8	-	-	-	-				
9	-	-	-	-				
10	Gear Motor	TC1125	2U0105-01	1	1	1	1	
11	Bearing (Lower)	Copper A Iloy	206013G03	1	1	1	1	
12	Ring	S.S	432494-01	1	1	1	1	
13	Mechanical Seal	HK9A-MS	432491-01	1	1	1	1	
14	Evaporator	-	321221G01	1	1	1	1	
15	Auger	S.S	320837G01	1	1	1	1	
16	Coupling - Spline	S.S	418316-01	1	1	1	1	
17	"0" Ring	P48	7616-P048	1	1	1	1	
18	"0" Ring	G40	7616-G040	1	1	1	1	
19	Socket Head Cap Screw	S.S, M8x14	429121-01	3	3	3	3	
20	Drip Plate (B)	S.S	412676-01	1	1	1	1	

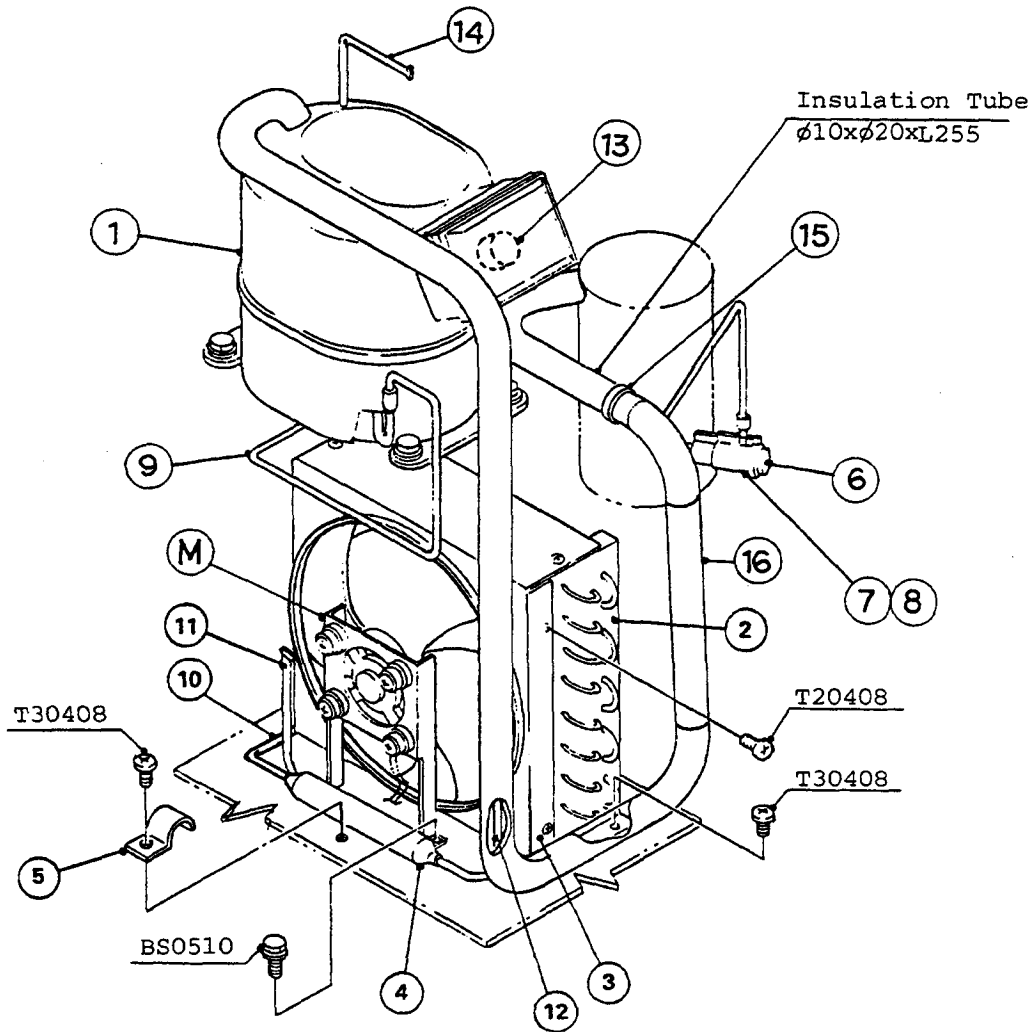

HA

MODEL		TITLE						
DCM-240BAA		C. REFRIGERATION UNIT						
INDEX NO.	DESCRIPTION	MATERIAL OR MODEL NUMBER	PART NUMBER	REQ'D NUMBER				
				J-1	K-0	K-1	A-0	
M	FAN MOTOR ASSEMBLY	(S-0375)	313392A01	1	1	1	1	
1	Compressor	CL50J-1U	2U0039-01	1	1	1	1	
2	Condenser - Air-cooled	-	203881-01	1	1	1	1	
3	Shroud	G.S	307663-01	1	1	1	1	
4	Drier	-	418462-01	1	1	1	1	
E	Strap	G.S	419349-01	1	1	1	1	
6	Expansion Valve	HYP2-5HD3	411518-03	1	1	1	1	
7	Cover (C) - Expansion Valve	PE Foam	307462-03	1	1	1	1	
8	Cover (D) - Expansion Valve	PE Foam	307462-04	1	1	1	1	
9	Pipe - High Side	Copper	424042-02	1	1	1	1	
10	Pipe - High Side	Copper	425241-01	1	1	1	1	
11	Process Tube	Copper	412644-01	1	1	1	1	
12	Pipe - Low Side	Copper	208270G03	1	1	1	1	
13	Over load	OL-091CL	3U0025-01	1	1	1	1	
14	Process Tube	Copper	424108-02	1	1	1	1	
15	Tie	CV-150	7920-0003	2	2	2	2	
16	Tape - Aluminum Foil	Aluminum	7810-0100	1	1	1	1	

MODEL		TITLE						
DCM-240BAA		D. WATER CIRCUIT ASSEMBLY						
INDEX NO.	DESCRIPTION	MATERIAL OR MODEL NUMBER	PART NUMBER	REQ'D NUMBER				
				J-1	K-0	K-1	A-0	
1	Pipe - Water Supply	S.S	315001G02	1	1	1	1	
2	Packing	NBR	413854-03	2	2	2	2	
3	Water Valve	J246-086	3U0065-01	1	1	1	1	
4	Cover - Reservoir Inlet	SI Rubber	415094-01	1	1	1	1	
5	Reservoir	ABS	207527-02	1	1	1	1	
6	Co l l a r	S.S	423416-01	1	1	1	1	
7	Cover - Reservoir	ABS	103070-02	1	1	1	1	
8	Float Switch	FFS-536B61B-21	417220-01	X				
		TW-1221-101	435490-01	①	1	1	1	
9	Separator - Reservoir	ABS	423538-01	1	1	1	1	
10	Water Valve	J246-317	3U0066-01	1	1	1	1	
11	Pipe - Water Supply	SI Rubber	427618-01	1	1	1	1	
12	Pipe - Joint	S.S	315002G01	1	1	1	1	
13	Cap - Drain	Brass	425629-01	1	1	1	1	
14	Packing - Drain	Sy.R	418071-03	1	1	1	1	
15	Clamp	HB20 T19	423866-02	1	1	1	1	
16	Clamp	HH-32N	421642-05	4	4	4	4	
17	Bushing	SR-30-1	420472-03	1	1	1	1	
18	Pipe - Drain	EPDH	429620-01	1	1	1	1	
19	Tie	CV-150	7920-0003	2	2	2	2	

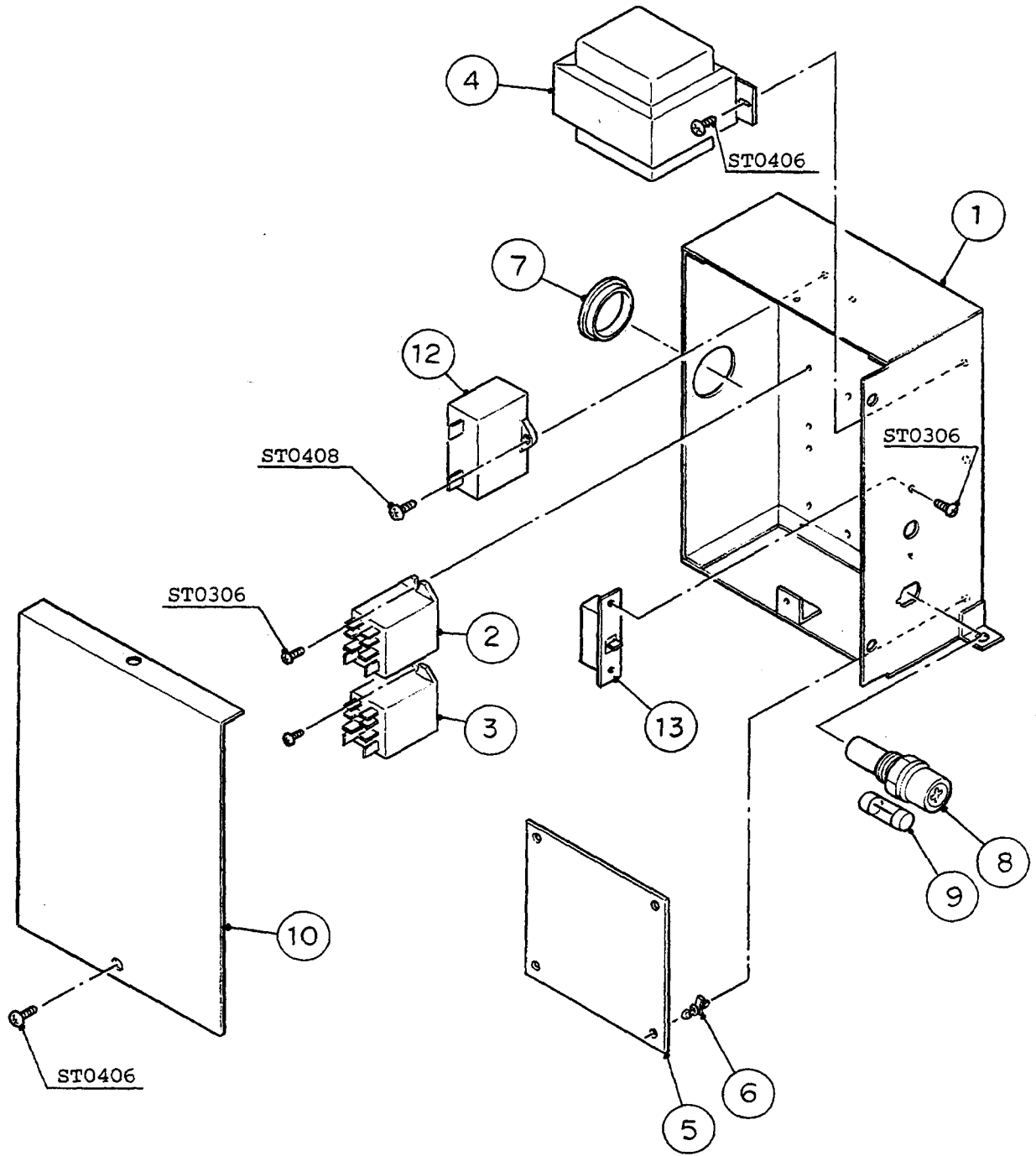

HA

MODEL		TITLE						
DCM-240BAA		E. CONTROL BOX (A) ASSEMBLY						
INDEX NO.	DESCRIPTION	MATERIAL OR MODEL NUMBER	PART NUMBER	REQ'D NUMBER				
				J-1	K-0	K-1	A-0	
1	Control Box (A)	G.S	322858G01	1	1	1	1	
2	Relay	LY2ZF	406132-06	1	1	1	1	
3	Relay	LY1F	418271-03	1	1	1	1	
4	Transformer	TR5267	2U0042-01	1	1	1	1	
5	Timer Board	426215	426215-01	1	1	X		
		H2AA144C02	437305-02			1	1	
6	Board Support	KGLS-6S	414929-01	4	4	4	4	
7	Bushing	SB-1093-15	420470-03	1	1	1	1	
8	Fuse Holder	FH032	424288-01	1	1	1	1	
9	Fuse	FGAO-2, 1A	420468-03	1	1	1	1	
10	Cover - Control Box(A)	G.S	425207-01	1	1	1	1	
11	-	-	-	-				
12	Capacitor	280VAC, 10UμF	412691-05	1	1	1	1	
13	Overload - Gear Motor	1.6A	427253-01	1	1	1	1	

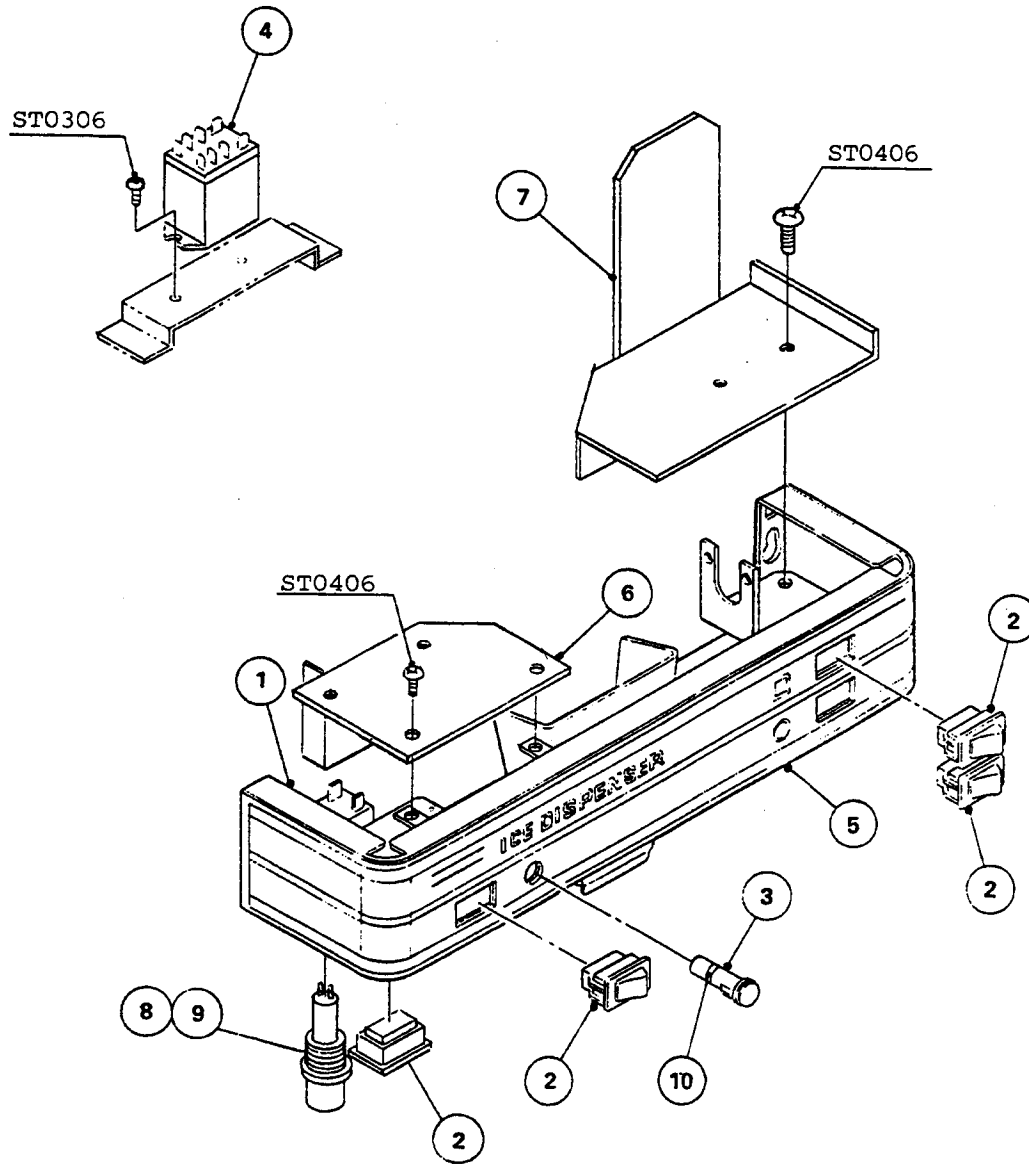

MODEL		TITLE						
DCM-240BAA		F. FRONT PANEL (MIDDLE) ASSEMBLY						
INDEX NO.	DESCRIPTION	MATERIAL OR MODEL NUMBER	PART NUMBER	REQ'D NUMBER				
				J-1	K-0	K-1	A-0	
1	Front Panel (Middle)	S.S	208100G01	1	1	1	1	
2	Rocker Switch	HLS112A	421490-01	4	4	4	4	
3	Lamp	A107P-PFN	423965-01	1	1	1	1	
4	Relay	LY1F	418271-03	1	1	1	1	
5	Label - Ice Dispenser	PETP Film	210593-01	1	1	1	1	
6	Barrier (Left)	G.S	425094-01	1	1	1	1	
7	Barrier (Right)	G.S	425095G01	1	1	1	1	
8	Fuse Holder	X-N2082	417006-01	1	1	1	1	
9	Fuse	314015 15A	420468-05	1	1	1	1	
10	Label - Lamp	Paper	427602-01	1	1	1	1	

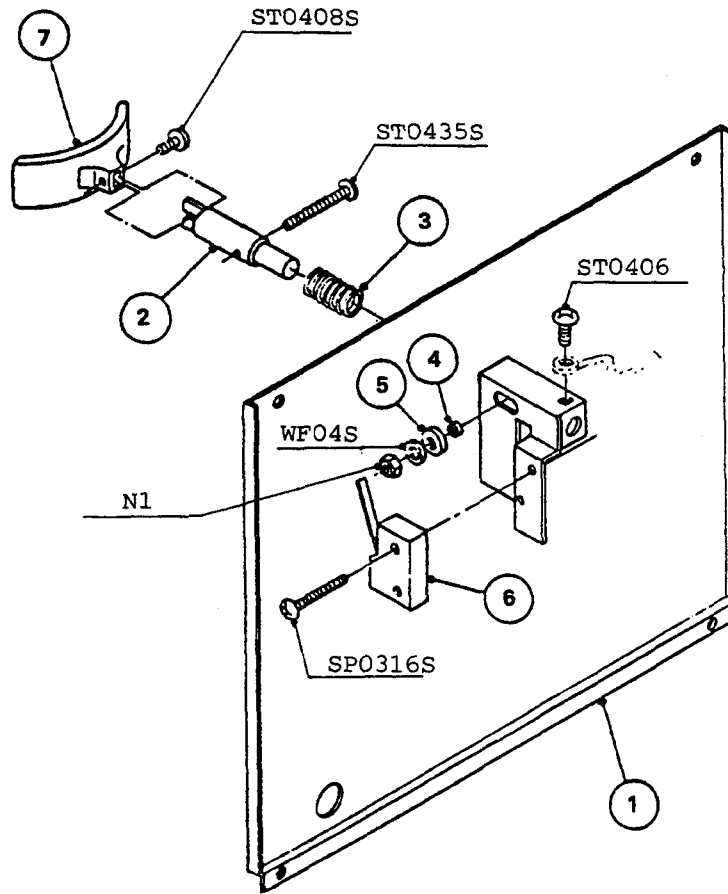

NI - U-Nut, O4S

MODEL		TITLE						
DCH-240BAA		G. FRONT PANEL (LOWER) ASSEMBLY						
INDEX NO.	DESCRIPTION	MATERIAL OR MODEL NUMBER	PART NUMBER	REQ'D NUMBER				
				J-1	K-0	K-1	A-0	
1	Front Panel (Lower)	S.S	315006G06	1	1	1	1	
2	Working Bar	AC	421606G01	1	1	1	1	
3	Spring	S.S	421608-01	1	1	1	1	
4	Co1lar	S.S	421609-01	X				
			421609-02		1	1	1	
5	Washer	S.T.W.FH 6x1	409659-05	1	1	1	1	
6	Micro switch	V-5L11155W	423950-01	1	1	1	1	
7	Push Lever	ABS	309671-01	1	1	1	1	

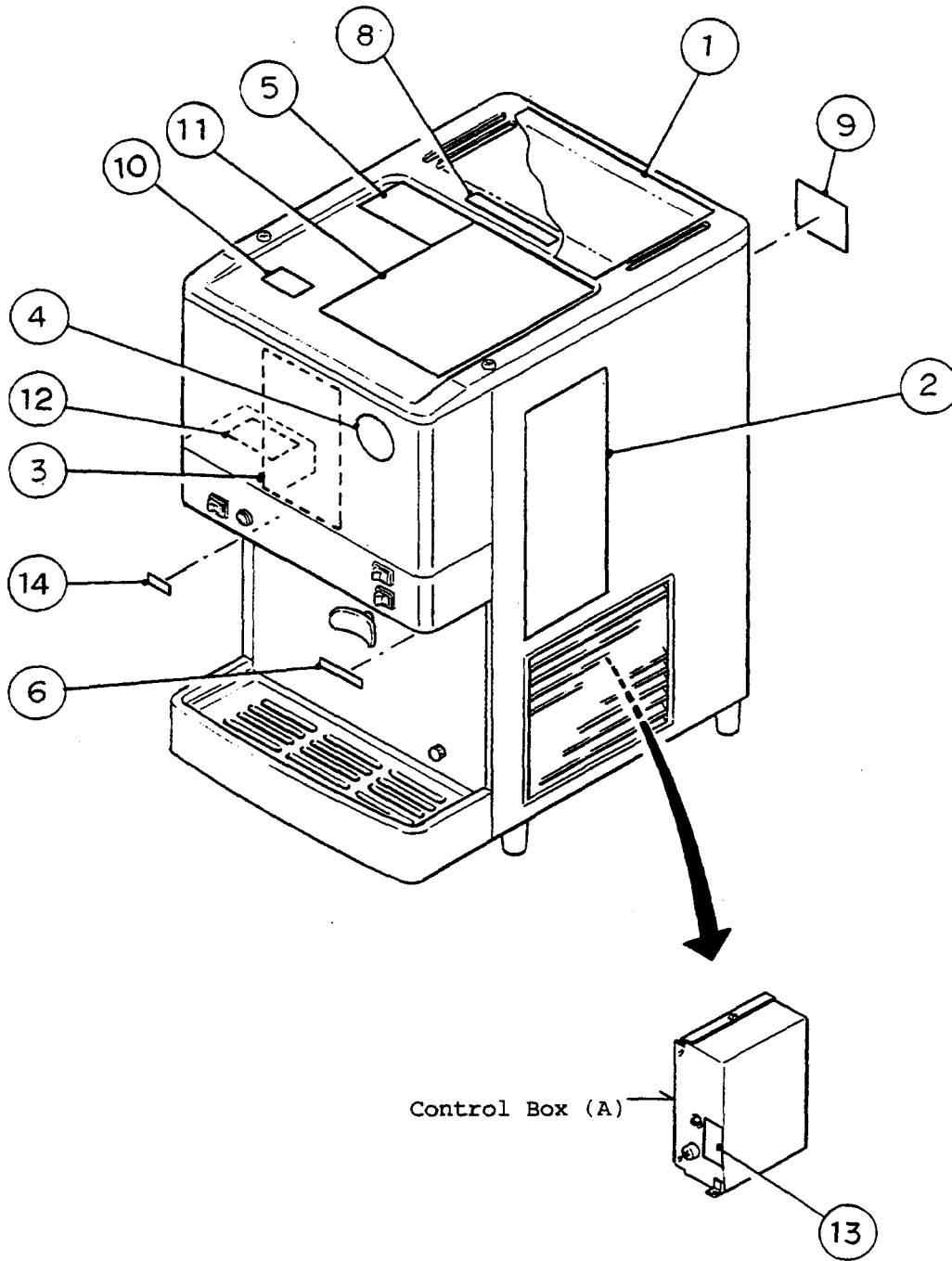

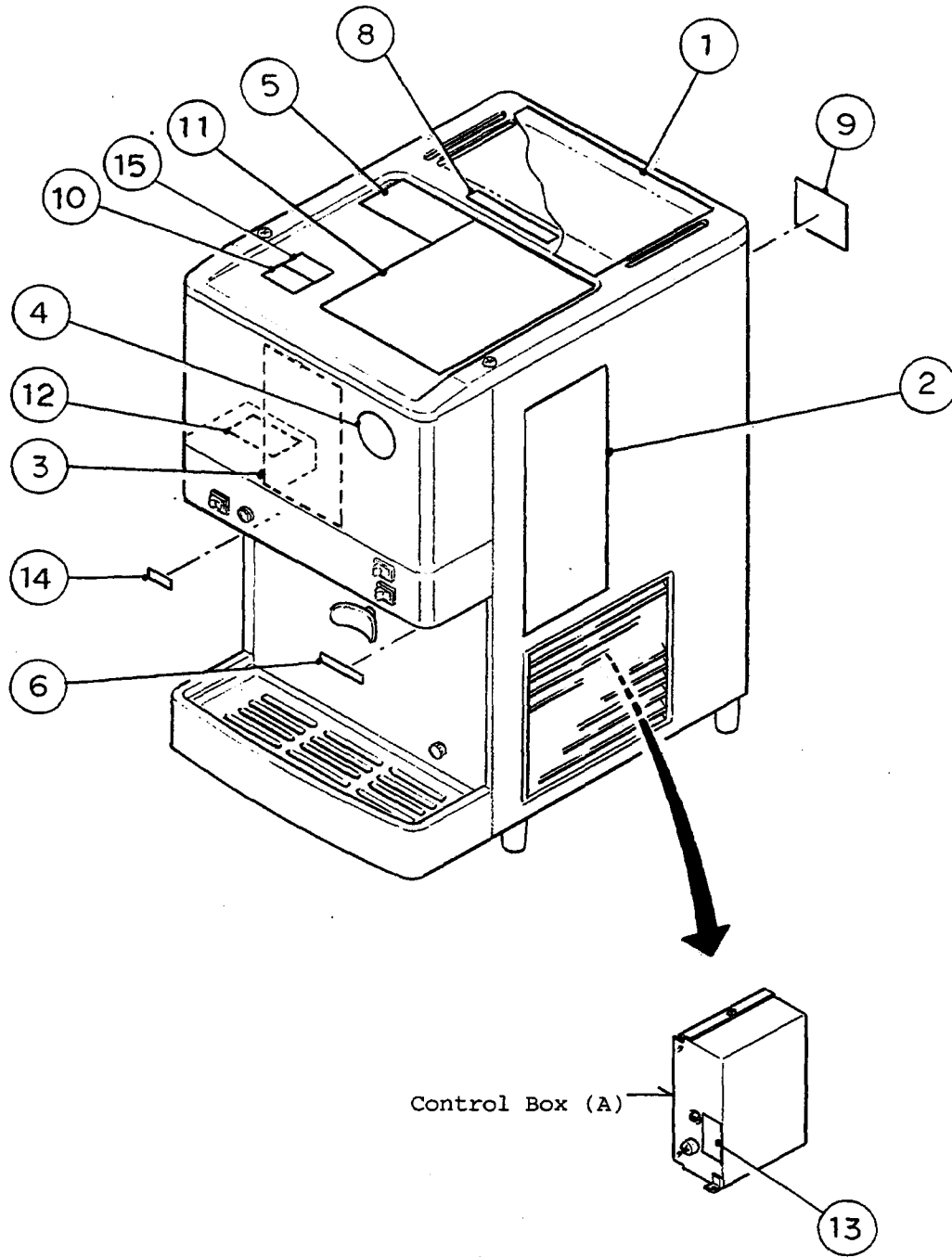

MODEL		TITLE						
DCM-240BAA		H. LABEL LOCATION						
INDEX NO.	DESCRIPTION	MATERIAL OR MODEL NUMBER	PART NUMBER	REQ'D NUMBER				
				J-1	K-0	K-1	A-0	
1	Instruction Sheet - Inst. Ope.	Paper	315755-01	1	1	1	1	
2	Label - Operation	PETP Film	315756-01	1	1	1	1	
3	Wiring Label	PVC Film	322864-01	1	1	1	1	
4	Label - Penguin	Aluminum	423949-01	1	1	1	1	
5	Label - Efficient Use	PETP Film	425319-01	1	1	1	1	
6	Model Number Label	PETP Film	435985-01	1	1	1	1	
7	-	-	-	-				
8	Label - Caution	PETP Film	425320-01	1	1	1	1	
9	Nameplate	PES Film	435263-01	1	1	-		
		PUR	437963-01			1	1	
10	Label - Danger	PVC Film	425322-01	1	1	1	1	
11	Label - Cleaning	PETP Film	208143-01	1	1	1	1	
12	Rating Label	PES Film	435324-01	1	1	1	1	
13	Label - Reset	PETP Film	435319-01	1	1	1	1	
14	Label - Fuse (15A)	PETP Film	425324-03	1	1	1	1	
15	Warning Label - CSA	PVC Film	437910-01			1	1	

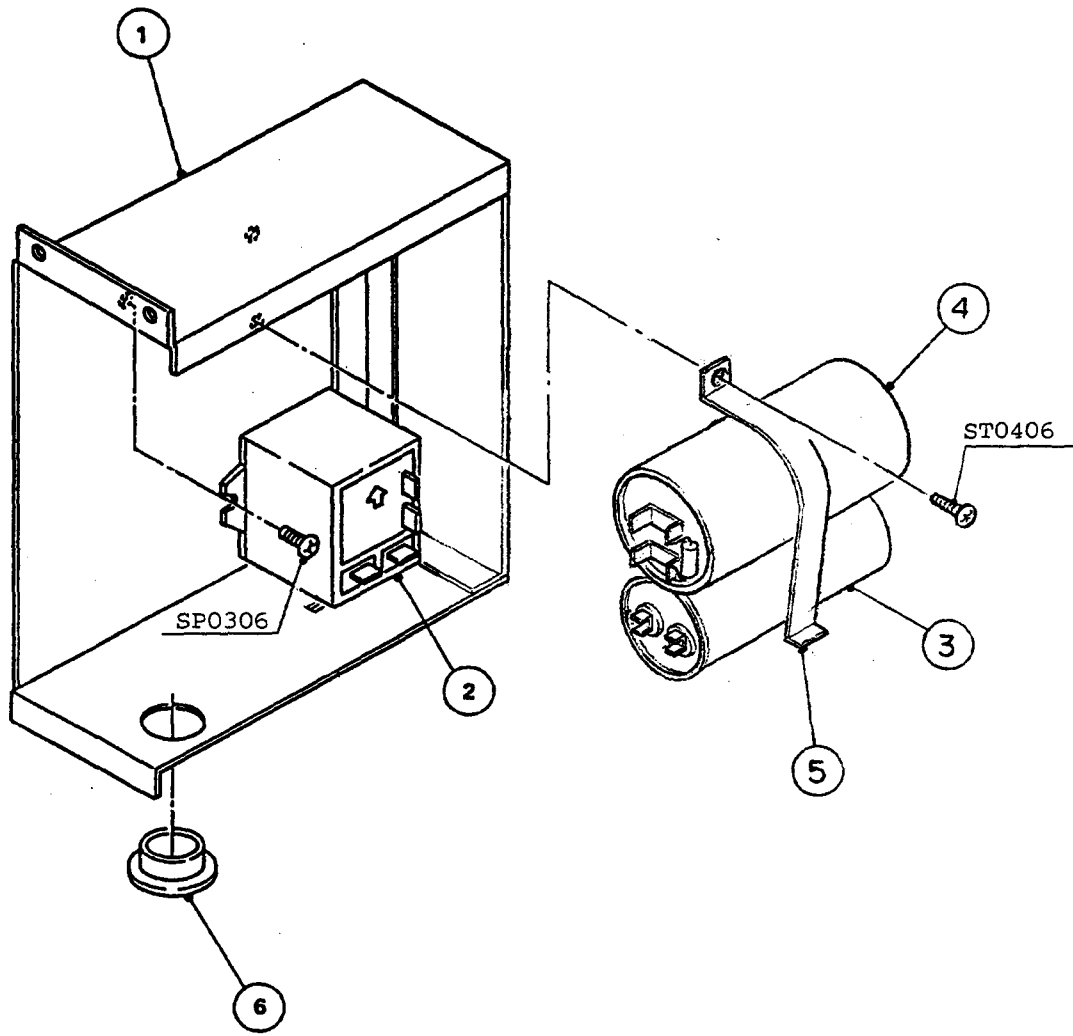

HA

MODEL		TITLE						
DCM-240BAA		J. CONTROL BOX (B) ASSEMBLY						
INDEX NO.	DESCRIPTION	MATERIAL OR MODEL NUMBER	PART NUMBER	REQ'D NUMBER				
				J-1	K-0	K-1	A-0	
1	Control Box (B)	G.S	320769G01	1	1	1	1	
2.	Starter	FST-180B	419843-01	1	1	1	1	
3	Run Capacitor	PMT-33300P	428391-02	1	1	1	1	
4	Start Capacitor	MS240F100(J)-R	426901-01	1	1	1	1	
e	Strap - Capacitor	G.S	432425-01	1	1	1	1	
6	Bushing	SB-750-10	420470-05	1	1	1	1	

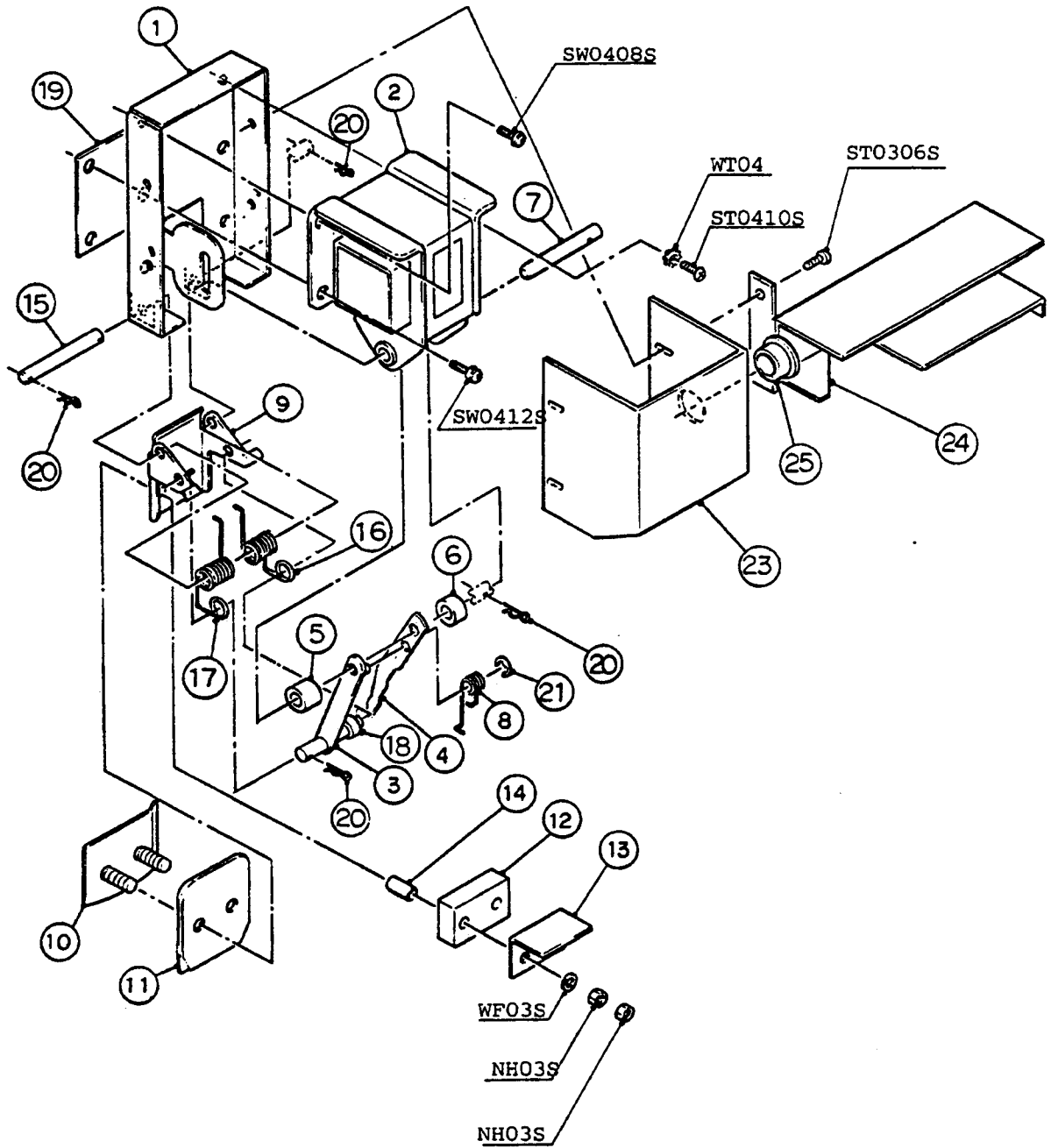

MODEL		TITLE						
DCM-240BAA		K. SHUTTER ASSEMBLY						
INDEX NO.	DESCRIPTION	MATERIAL OR MODEL NUMBER	PART NUMBER	REQ'D NUMBER				
				J-1	K-0	K-1	A-0	
1	Bracket - Solenoid	S.S	320896G02	1	1	1	1	
2	Solenoid	AS-20-N042	422692-01	1	1	-		
		AS-20-N075	437926-01			1	1	
3	Plate	S.S	433088G02	1	1	1	1	
4	Lock Plate	S.S	432516-02	1	1	X		
	Hook - Shutter	S.S	438406-01				1	
5	Collar (A)	S.S	432524-01	1	1	1	1	
6	Collar (B)	S.S	432524-02	1	1	1	1	
7	Shaft (A) - Solenoid	S.S	432517-02	1	1	1	1	
8	Spring	S.S	411532-01	1	1	1	1	
9	Stopper	S.S	432518-03	1	1	1	1	
10	Plate	S.S	423946G01	1	1	1	1	
11	Plate (B) - Shutter	EPDH	423948-01	1	1	1	1	
12	Cushion	Sy.R Foam	419150-01	1	1	1	1	
13	Plate (D)	S.S	419151-01	1	1	1	1	
14	Collar (C) - Shutter	S.S	411539-03	2	2	2	2	
15	Shaft (A)	S.S	432523-01	1	1	1	1	
16	Spring (Right)	S.S	434478-01	1	1	1	1	
17	Spring (Left)	S.S	434479-01	1	1	1	1	
18	Spring (B2)	S.S	432520-02	1	1	1	1	
19	Spacer	ABS	432514-01	1	1	1	1	
20	Snap Pin	S.S	715S-0005	4	4	4	4	
21	"E" Ring	S.S	721S-0004	1	1	1	1	
22	-	-	-	-				
23	Barrier - Solenoid	S.S	433269-01	1	1	1	1	
24	Barrier - Valve	S.S	433270G01	1	1	1	1	
25	Bushing	SB-625-8	420470-01	1	1	1	1	

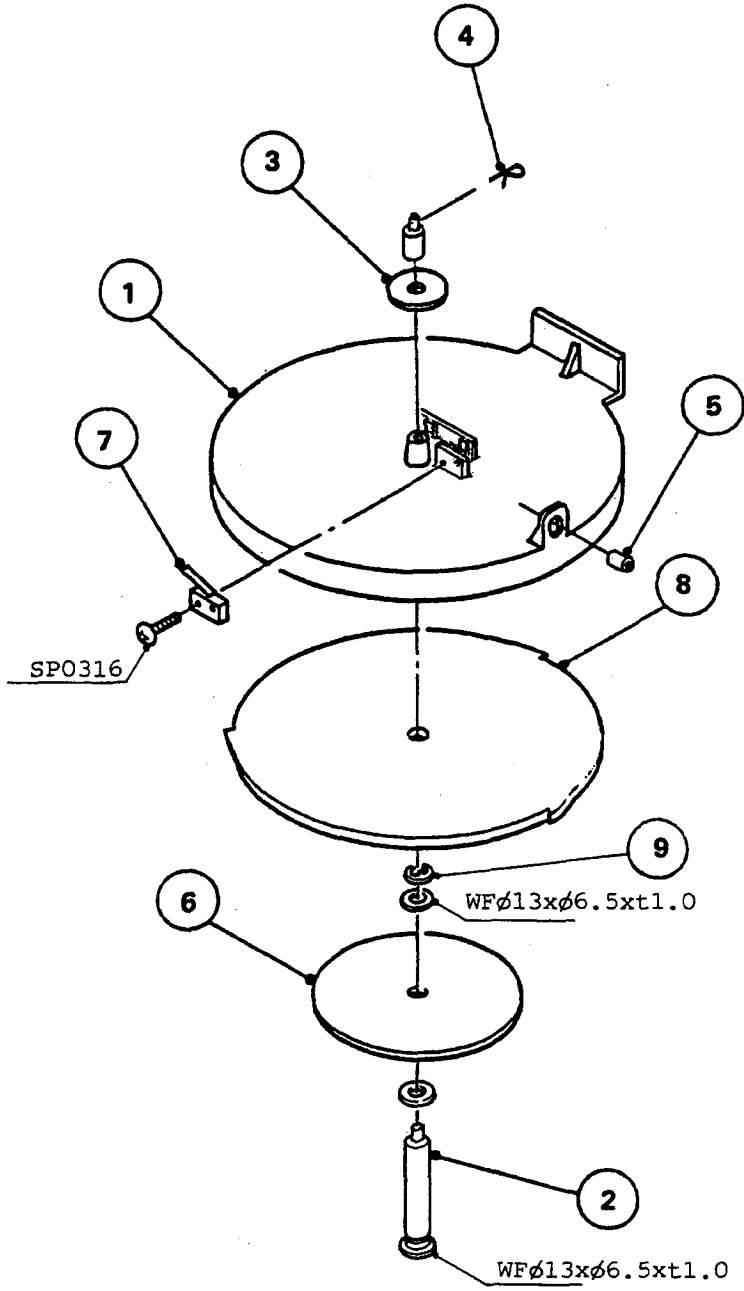

MODEL		TITLE						
DCM-240BAA		L. COVER ASSEMBLY - BIN TOP						
INDEX NO.	DESCRIPTION	MATERIAL OR MODEL NUMBER	PART NUMBER	REQ'D NUMBER				
				J-1	K-0	K-1	A-0	
1	Cover - Bin Top	ABS	103829G01	1	1	1	1	
2	Shaft	S.S	423958-01	1	1	1	1	
3	Balance Plate	S.S	423959-01	1	1	1	1	
4	Snap Pin	S.S, SSP-4	715S-0004	1	1	1	1	
E	Bushing	SR-30-1	420472-03	1	1	1	1	
6	Balance Plate	ABS	417473-02	1	1	1	1	
7	Microswitch	V-5L11155W	423950-01	1	1	1	1	
8	Inside Plate	ABS	207830-01	1	1	1	1	
9	"E" Ring	S.S	721S-0005	1	1	1	1	

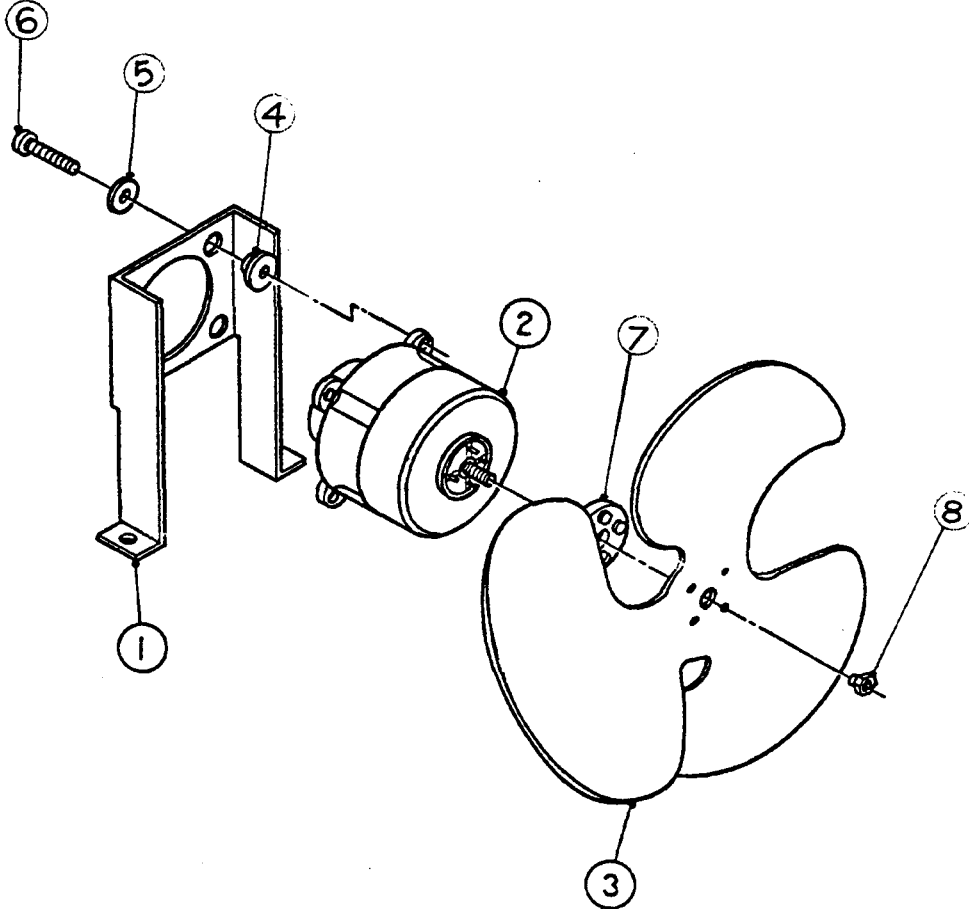

HA

MODEL		TITLE						
DCM-240BAA		M. FAN MOTOR ASSEMBLY						
INDEX NO.	DESCRIPTION	MATERIAL OR MODEL NUMBER	PART NUMBER	REQ'D NUMBER				
				J-1	K-0	K-1	A-0	
1	Bracket (B) - Fan Motor	G.S	307282-02	1	1	1	1	
2	Fan Motor	EK-TZ2	2U0005-01	1	1	1	1	
3	Fan Blade	Aluminum	414392-01	1	1	1	1	
4	Grommet (A)	-	414390F01	4	4	4	4	
5	Washer - Grommet	-	414390F03	8	8	8	8	
6	Screw	-	414390F05	4	4	4	4	
7	Pad	-	414390F06	1	1	1	1	
8	Nut	-	414390F07	1	1	1	1	

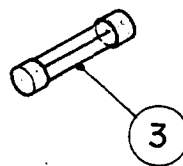
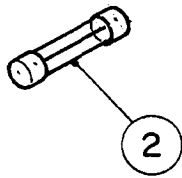
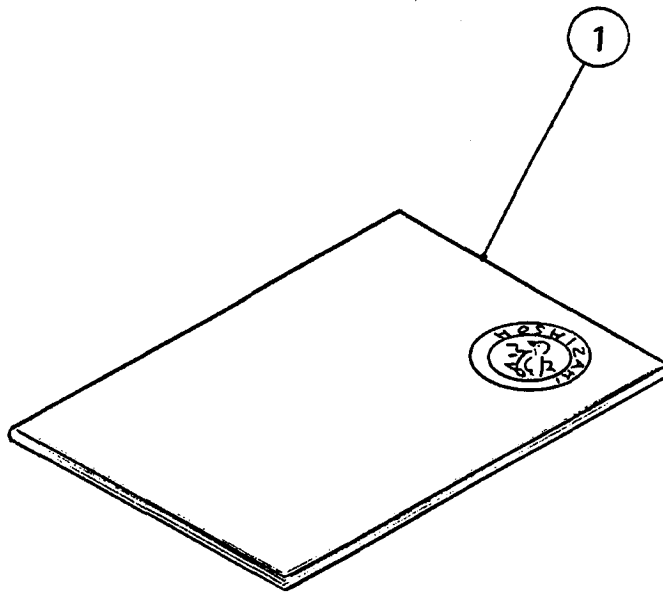

HA

MODEL		TITLE						
DCM-240BAA		N. ACCESSORIES						
INDEX NO.	DESCRIPTION	MATERIAL OR MODEL NUMBER	PART NUMBER	REQ'D NUMBER				
				J-1	K-0	K-1	A-0	
1	Instruction Manual	Paper	91U2GJ10A	1	1	X		
			91U2GJ10B				1	
2	Fuse	F.G.A.0-2, AC250V, 1A	420468-03	1	1	1	1	
3	Fuse	314015, AC250V, 15A	420468-05	1	1	1	1	