

NO. U2GR-1038
ISSUED: DEC. 17, 1991
REVISED: JUN. 15, 1994



HOSHIZAKI CUBELET ICE DISPENSER

MODEL DCM-240BAB

PARTS LIST

A-1	MAR.	1991
A-2	JUL.	1991
B-0	DEC.	1991
B-1	JAN.	1992
B-2	JAN.	1992
B-3	JUN.	1992
C-1	DEC.	1992
C-2	APR.	1993

FINAL

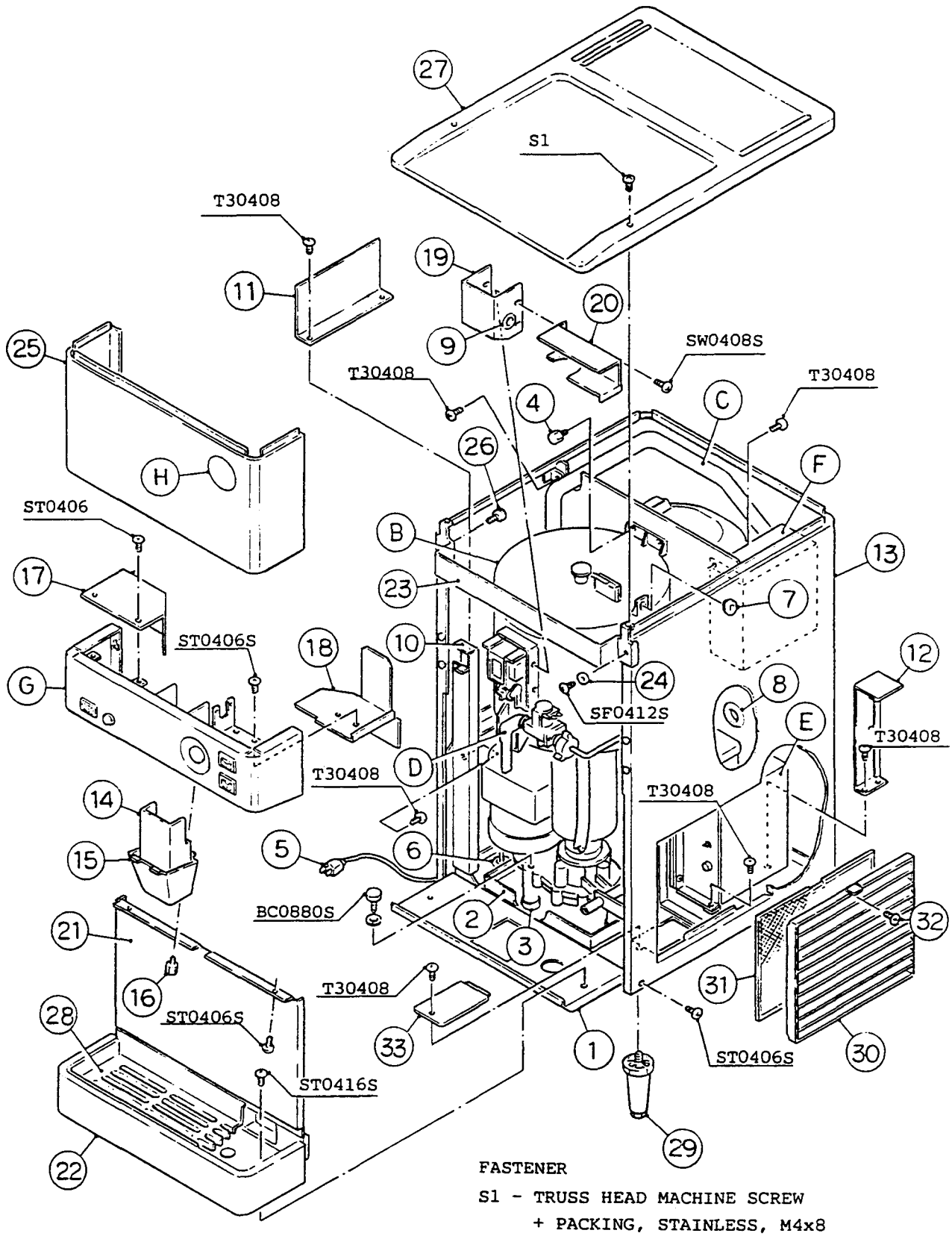

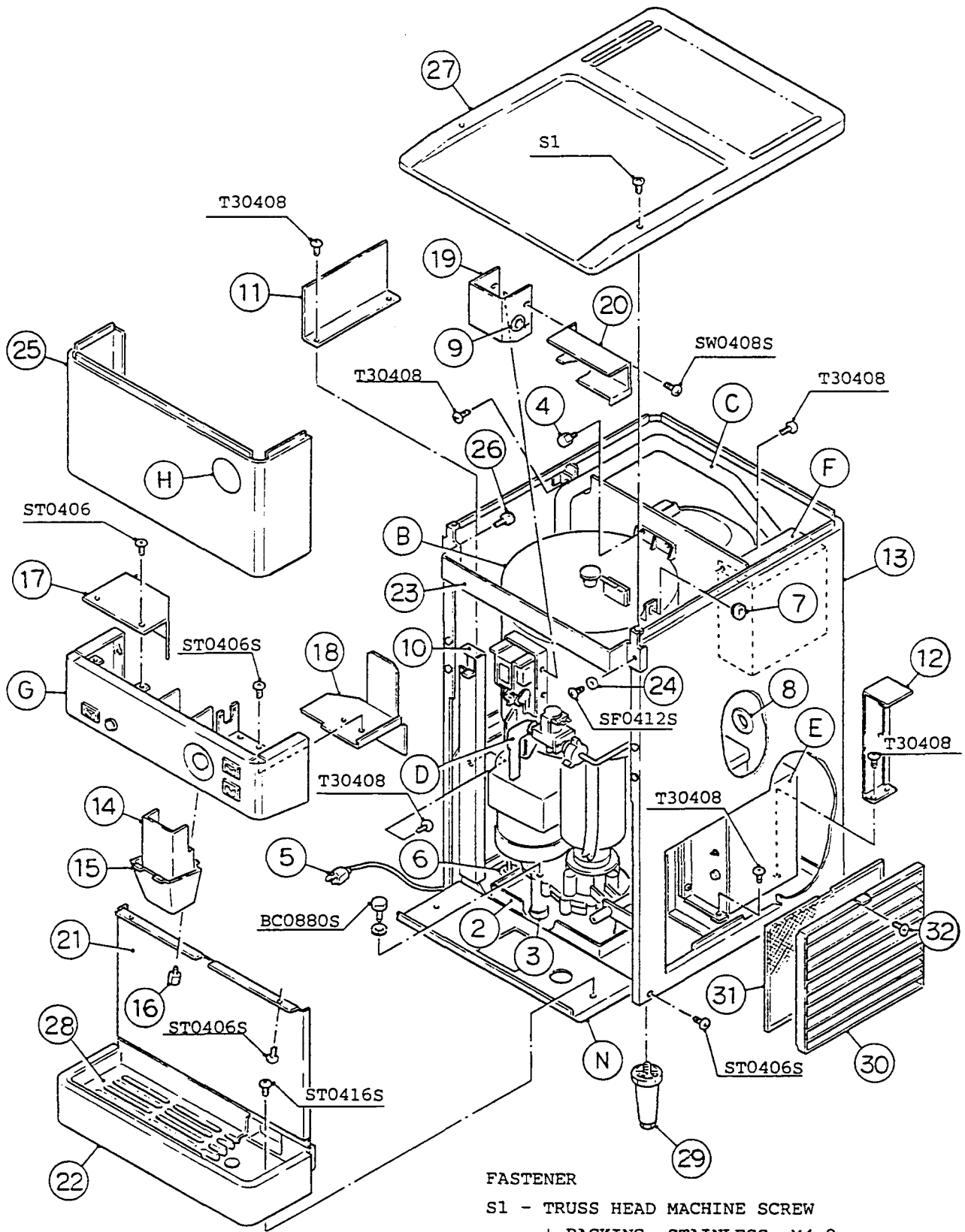

FASTENER

S1 - TRUSS HEAD MACHINE SCREW
+ PACKING, STAINLESS, M4x8

HA

MODEL: DCM-240BAB TITLE: A. ICE DISPENSER ASSY							
INDEX NO.	DESCRIPTION	MATERIAL OR MODEL NUMBER	PART NUMBER	REQD NUMBER			
				A-1	A-2	B-0	B-1
B	EVAPORATOR ASSY	-	211325A06	1	-		
		-	211325A07		1	1	1
C	REFRIGERATION CIRCUIT	-	105403A01	1	1	1	1
D	WATER CIRCUIT	-	105416A01	1	1	1	1
E	CONTROL BOX (A)	-	327131A01	1	1	1	1
F	CONTROL BOX (B)	-	327128A01	1	1	1	1
G	MIDDLE FRONT PANEL ASSY	-	327158A01	1	1	1	1
H	LABEL LOCATION	-	327199A01	1	1	1	1
N	FRAME	-	106031A01				1
1	FRAME	G.S	105402G01	1	1	1	-
2	DRAIN PAN	S.S	440927-01	1	1	1	1
3	SPACER	PVC	440956-01	3	3	3	3
4	THUMBSCREW	ABS, S.S	415949G04	2	2	2	2
5	POWER SUPPLY CORD	KP-30B	421824-01	1	1	1	1
6	BUSHING	SR-7K-2	420472-02	1	1	1	1
7	BUSHING	SR-30-1	420472-03	2	2	2	2
8	BUSHING	SB-1500-21	420470-06	2	2	2	2
9	BUSHING	SB-625-8	420470-01	1	1	1	1
10	BARRIER (C)	G.S	425093-01	1	1	1	1
11	BARRIER (D)	G.S	440906-01	1	1	1	1
12	BARRIER (E)	G.S	425637-01	1	1	1	1
13	CABINET	S.S	424987G12	1	1	1	-
		S.S	443162G03				1
14	SPOUT (A)	ABS	105409-01	1	1	1	1
15	SPOUT (B)	ABS	105410-01	1	1	1	1
16	THUMBSCREW	S.S, ABS	415949G08	1	1	1	1
17	FRONT BARRIER L	G.S	425094-01	1	1	1	1
18	FRONT BARRIER R	G.S	440433G01	1	1	1	1
19	BARRIER / SOLENOID	S.S	433269-01	1	1	1	1
20	WV BARRIER	S.S	440432-01	1	1	1	1
21	APRON PANEL	S.S	327163-01	1	1	1	1

HA

MODEL: DCM-240BAB TITLE: A. ICE DISPENSER ASSY							
INDEX NO.	DESCRIPTION	MATERIAL OR MODEL NUMBER	PART NUMBER	REQD NUMBER			
				B-2	B-3	C-1	C-2
B	EVAPORATOR ASSY	-	211325A07	1	1	1	1
C	REFRIGERATION CIRCUIT	-	105403A01	1	1	1	1
D	WATER CIRCUIT	-	105416A01	1	1	1	1
E	CONTROL BOX (A)	-	327131A01	1	1	1	1
F	CONTROL BOX (B)	-	327128A01	1	1	1	1
G	MIDDLE FRONT PANEL ASSY	-	327158A01	1	1	1	1
H	LABEL LOCATION	-	327199A01	1	1	1	1
N	FRAME	-	106031A01	1	1	1	1
1		-		-			
2	DRAIN PAN	S.S	440927-01	1	1	1	1
3	SPACER	PVC	440956-01	3	3	3	3
4	THUMBSCREW	ABS, S.S	415949G04	2	2	2	2
5	POWER SUPPLY CORD	KP-30B	421824-01	1	1	1	1
6	BUSHING	SR-7K-2	420472-02	1	1	1	1
7	BUSHING	SR-30-1	420472-03	2	2	2	2
8	BUSHING	SB-1500-21	420470-06	2	2	2	2
9	BUSHING	SB-625-8	420470-01	1	1	1	1
10	BARRIER (C)	G.S	425093-01	1	1	1	1
11	BARRIER (D)	G.S	440906-01	1	1	1	1
12	BARRIER (E)	G.S	425637-01	1	1	1	1
13	CABINET	S.S	443162G03	1	1	-	
		S.S	424987G12			1	1
14	SPOUT (A)	ABS	105409-01	1	1	1	1
15	SPOUT (B)	ABS	105410-01	1	1	1	1
16	THUMBSCREW	S.S, ABS	415949G08	1	1	1	1
17	FRONT BARRIER L	G.S	425094-01	1	1	1	1
18	FRONT BARRIER R	G.S	440433G01	1	1	1	1
19	BARRIER/SOLENOID	S.S	433269-01	1	1	1	1
20	WV BARRIER	S.S	440432-01	1	1	1	1
21	APRON PANEL	S.S	327163-01	1	1	1	1

HA

MODEL: DCM-240BAB TITLE: A. ICE DISPENSER ASSY							
INDEX NO.	DESCRIPTION	MATERIAL OR MODEL NUMBER	PART NUMBER	REQD NUMBER			
				A-1	A-2	B-0	B-1
22	DRAIN PAN AD	ABS	318857G02	1	1	1	-
		ABS	318857G03				1
23	BRACKET	G.S	424988-02	1	1	1	1
24	COLLAR	S.S	4H0171-01	1	1	1	1
25	FRONT PANEL	S.S	216359G01	1	1	1	-
		S.S	216359G02				1
26	THUMBSCREW	S.S	425221-01	1	1	1	1
27	TOP PANEL (A)	G.S	104679-01	1	1	1	-
	TOP PANEL (E)	G.S	104679-05				1
28	GRILLE	ABS	102936-02	1	1	1	-
		ABS	102936-03				1
29	ADJUSTABLE LEG	222-P-16B	417192-01	4	4	4	4
30	LOUVER	ABS	103344-01	1	1	1	-
		ABS	103344-05				1
31	AIR FILTER	ABS	208840G01	1	1	1	1
32	TAPPING SCREW / BRADE	4x8	433954-01	1	1	1	1
33	COVER - CHASSIS	G.S	436917-01	1	1	1	-

HA

MODEL: DCM-240BAB TITLE: A. ICE DISPENSER ASSY							
INDEX NO.	DESCRIPTION	MATERIAL OR MODEL NUMBER	PART NUMBER	REQD NUMBER			
				B-2	B-3	C-1	C-2
22	DRAIN PAN AD	ABS	318857G03	1	1	1	1
23	BRACKET	G.S	424988-02	1	1	1	1
24	COLLAR	S.S	4H0171-01	1	1	1	1
25	FRONT PANEL	S.S	216359G02	1	1	-	
		S.S	216359G01			1	1
26	THUMBSCREW	S.S	425221-01	1	1	1	1
27	TOP PANEL (E)	G.S	104679-05	1	1	1	1
28	GRILLE	ABS	102936-03	1	1	1	1
29	ADJUSTABLE LEG	222-P-16B	417192-01	4	4	4	4
30	LOUVER	ABS	103344-05	1	1	1	1
31	AIR FILTER	ABS	208840G01	1	1	1	1
32	TAPPING SCREW / BRADE	4x8	433954-01	1	1	1	1
33	-	-	-	-			

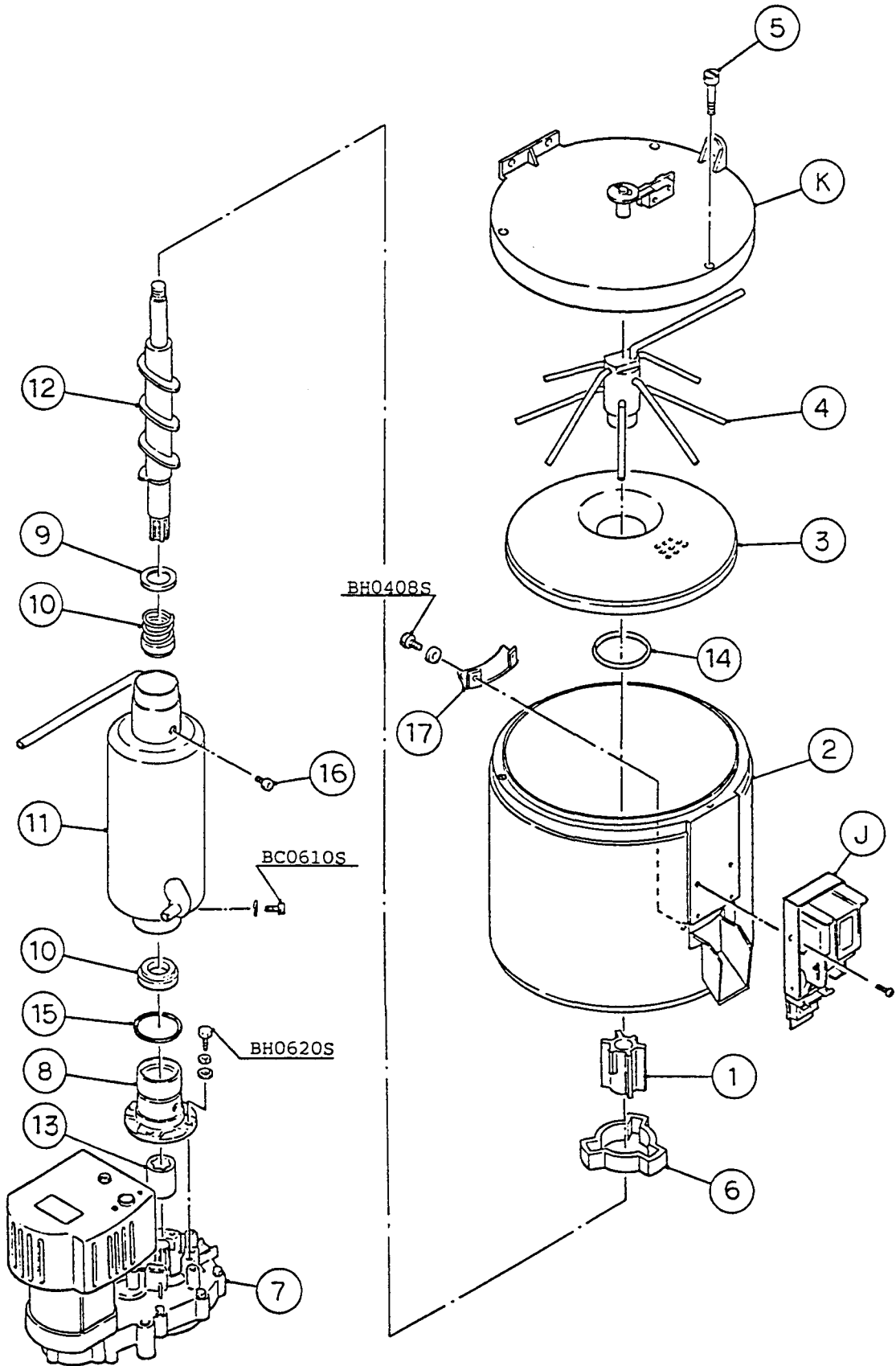

HA

MODEL: DCM-240BAB TITLE: B. EVAPORATOR ASSY							
INDEX NO.	DESCRIPTION	MATERIAL OR MODEL NUMBER	PART NUMBER	REQD NUMBER			
				A-1	A-2	B-0	B-1
J	SHUTTER ASSY	-	211265A06	1	-		
		-	211265A09		1	1	1
K	COVER ASSY-BIN TOP	-	207757A01	1	1	1	1
1	EXTRUDING HEAD	S.S	311407G02	1	1	1	1
2	STORAGE BIN	-	211630G01	1	1	1	1
3	DRIP RING	S.S	207754-01	1	1	1	1
4	AGITATOR	S.S	314997G01	1	1	1	1
5	THUMBSCREW	S.S, ABS	430825G01	3	3	3	3
6	COVER - UPPER, EVAPORATOR	FE FOAM	413446-01	1	1	1	1
7	GEAR MOTOR	TC1125, 120V80W	2U0105-01	1	1	1	1
8	HOUSING	COPPER ALLOY	206013G03	1	1	1	1
9	RING	S.S	432494-01	1	1	1	1
10	MECHANICAL SEAL	HK9A-MS	432491-01	1	1	1	1
11	EVAPORATOR	-	321221G01	1	-		
		-	327779G01		1	1	1
12	AUGER	S.S	320837G01	1	1	1	1
13	COUPLING - SPLINE	S.S	418316-01	1	1	1	1
14	"0" RING	P48	7616-P048	1	1	1	1
15	"0" RING	G40	7616-G040	1	1	1	1
16	SOCKET HEAD CAP SCREW	S.S, M8x14	429121-01	3	3	3	3
17	DRIP PLATE (B)	S.S	412676-01	1	1	1	1

HA

MODEL: DCM-240BAB TITLE: B. EVAPORATOR ASSY							
INDEX NO.	DESCRIPTION	MATERIAL OR MODEL NUMBER	PART NUMBER	REQD NUMBER			
				B-2	B-3	C-1	C-2
J	SHUTTER ASSY	-	211265A09	1	1	1	1
K	COVER ASSY - BIN TOP	-	207757A01	1	1	1	1
1	EXTRUDING HEAD	S.S	311407G02	1	1	1	1
2	STORAGE BIN	-	211630G01	1	1	1	1
3	DRIP RING	S.S	207754-01	1	1	1	1
4	AGITATOR	S.S	314997G01	1	1	1	1
5	THUMBSCREW	S.S, ABS	430825G01	3	3	3	3
6	COVER - UPPER, EVAPORATOR	FEFOAM	413446-01	1	1	1	1
7	GEAR MOTOR	TC1125, 120V80W	2U0105-01	1	1	1	1
8	HOUSING	COPPER ALLOY	206013G03	1	1	1	1
9	RING	S.S	432494-01	1	1	1	1
10	MECHANICAL SEAL	HK9A-MS	432491-01	1	1	1	1
11	EVAPORATOR	-	327779G01	1	1	1	1
12	AUGER	S.S	320837G01	1	1	1	1
13	COUPLING - SPLINE	S.S	418316-01	1	1	1	1
14	"0" RING	P48	7616-P048	1	1	1	1
15	"0" RING	G40	7616-G040	1	1	1	1
16	SOCKET HEAD CAP SCREW	S.S, M8x14	429121-01	3	3	3	3
17	DRIP PLATE (B)	S.S	412676-01	1	1	1	1

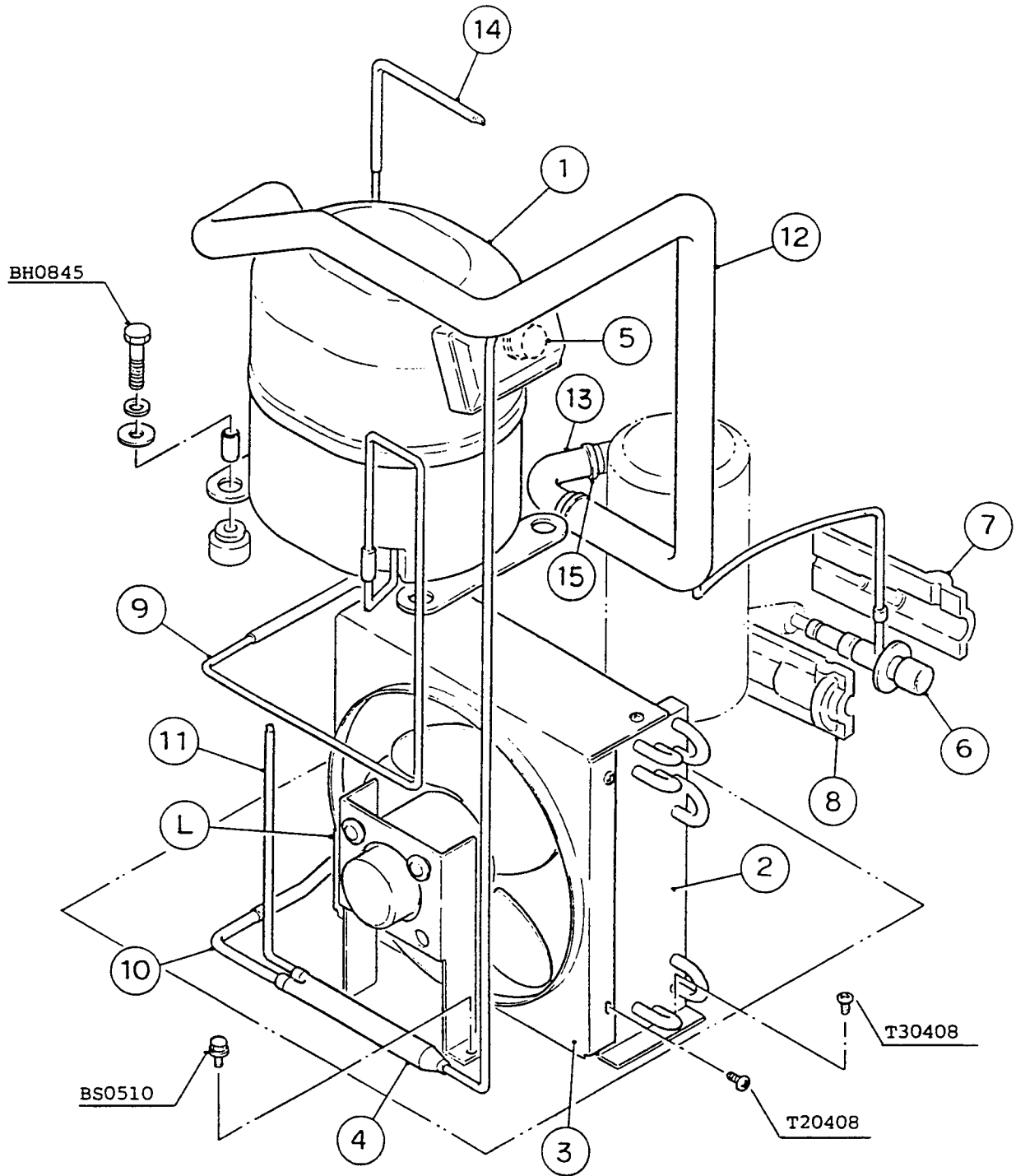

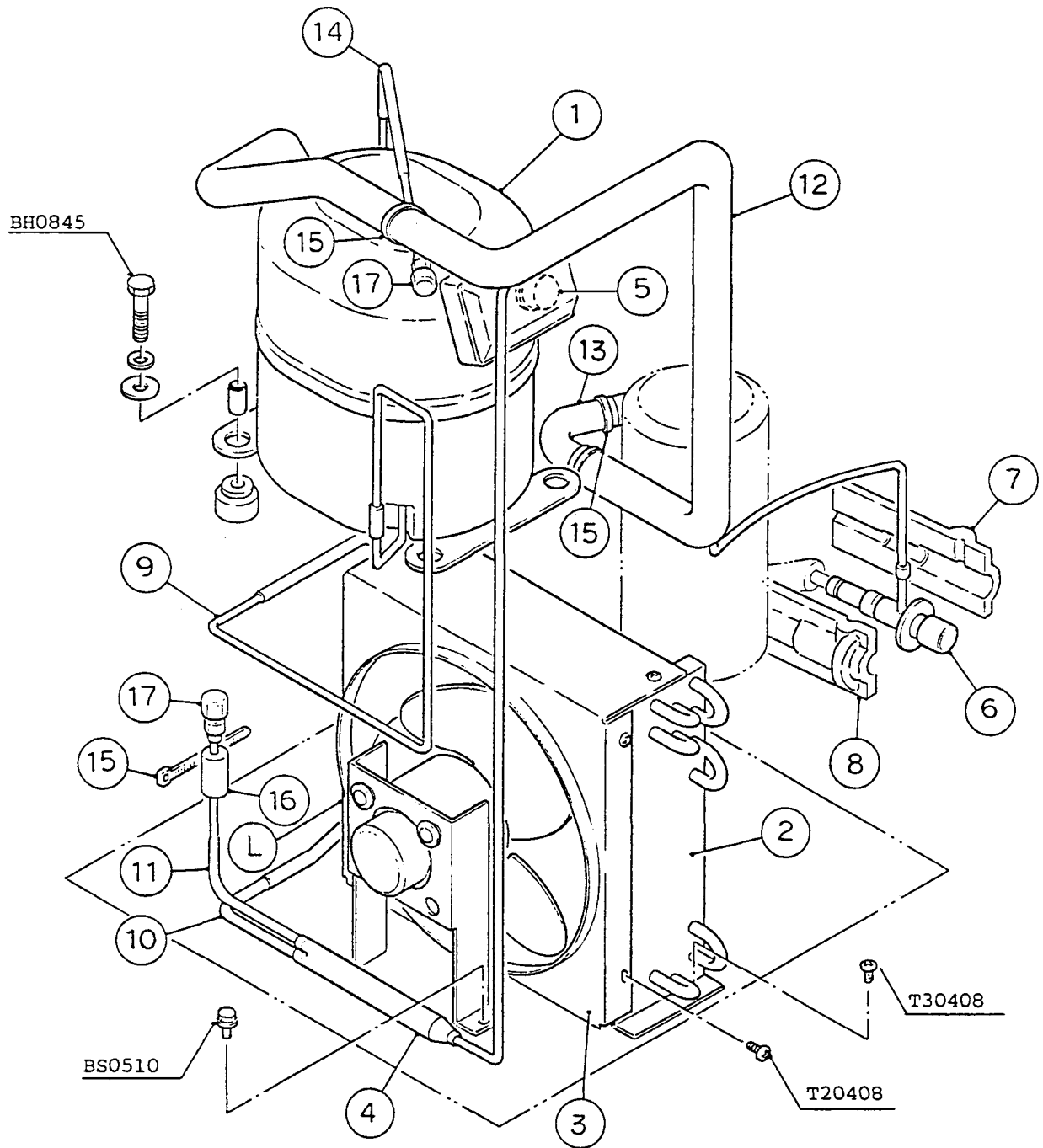

HA

MODEL: DCM-240BAB TITLE: C. REFRIGERATION CIRCUIT							
INDEX NO.	DESCRIPTION	MATERIAL OR MODEL NUMBER	PART NUMBER	REQD NUMBER			
				A-1	A-2	B-0	B-1
L	FAN MOTOR ASSY	(S-0375)	313392A01	1	1	1	1
1	COMPRESSOR	CL50J-1U	2U0039-01	1	1	1	1
2	CONDENSER - AIR-COOLED	-	203881-01	1	1	1	1
3	SHROUD	G.S	307663-01	1	1	1	1
4	DRIER	-	418462-01	1	1	1	1
5	OVERLOAD	OL-091CL	421511-01	1	1	1	1
6	EXPANSION VALVE	HYP2-5HD3	411518-03	1	1	1	1
7	COVER (C)-EXPANSION VALVE	PE FOAM	307462-03	1	1	1	1
8	COVER (D)-EXPANSION VALVE	PE FOAM	307462-04	1	1	1	1
9	PIPE - HIGH SIDE	COPPER	424042-04	1	1	1	1
10	PIPE - HIGH SIDE	COPPER	425241-02	1	1	1	1
11	PROCESS TUBE	COPPER	412644-01	1	1	1	1
12	HEAT EXCHANGER	COPPER	216324G01	1	1	1	1
13	INSULATION TUBE	L=240	7762-1020	1	1	1	1
14	PROCESS TUBE	COPPER	424108-02	1	1	1	1
15	TIE	CV-150	7920-0003	3	3	3	3

HA

MODEL: DCM-240BAB TITLE: C. REFRIGERATION CIRCUIT							
INDEX NO.	DESCRIPTION	MATERIAL OR MODEL NUMBER	PART NUMBER	REQD NUMBER			
				B-2	B-3	C-1	C-2
L	FAN MOTOR ASSY	(S-0375)	313392A01	1	1	1	1
1	COMPRESSOR	CL50J-1U	2U0039-01	1	1	1	1
2	CONDENSER - AIR-COOLED	-	203881-01	1	1	1	1
3	SHROUD	G.S	307663-01	1	1	1	1
4	DRIER	-	418462-01	1	1	1	1
5	OVERLOAD	OL-091CL	421511-01	1	1	1	1
6	EXPANSION VALVE	HYP2-5HD3	411518-03	1	1	1	1
7	COVER (C)-EXPANSION VALVE	PE FOAM	307462-03	1	1	1	1
8	COVER (D)-EXPANSION VALVE	PE FOAM	307462-04	1	1	1	1
9	PIPE - HIGH SIDE	COPPER	424042-04	1	1	1	1
10	PIPE - HIGH SIDE	COPPER	425241-02	1	1	1	1
11	PROCESS TUBE	COPPER	412644-01	1	-		
	COPPER TUBE (B) - ACCESS VALVE	COPPER	444605-01		1	1	1
12	HEAT EXCHANGER	COPPER	216324G01	1	1	1	1
13	INSULATION TUBE	7762-1020, L=240	105403-25	1	1	1	1
14	PROCESS TUBE	COPPER	424108-02	1	-		
	COPPER TUBE - ACCESS VALVE	COPPER	444604-01		1	1	1
15	TIE	CV-150	7920-0003	3	5	5	5
16	INSULATION TUBE	7762-0717, L=30	105403-27		1	1	1
17	ACCESS VALVE	TCJ-2F15-HD	417366-01		2	2	2

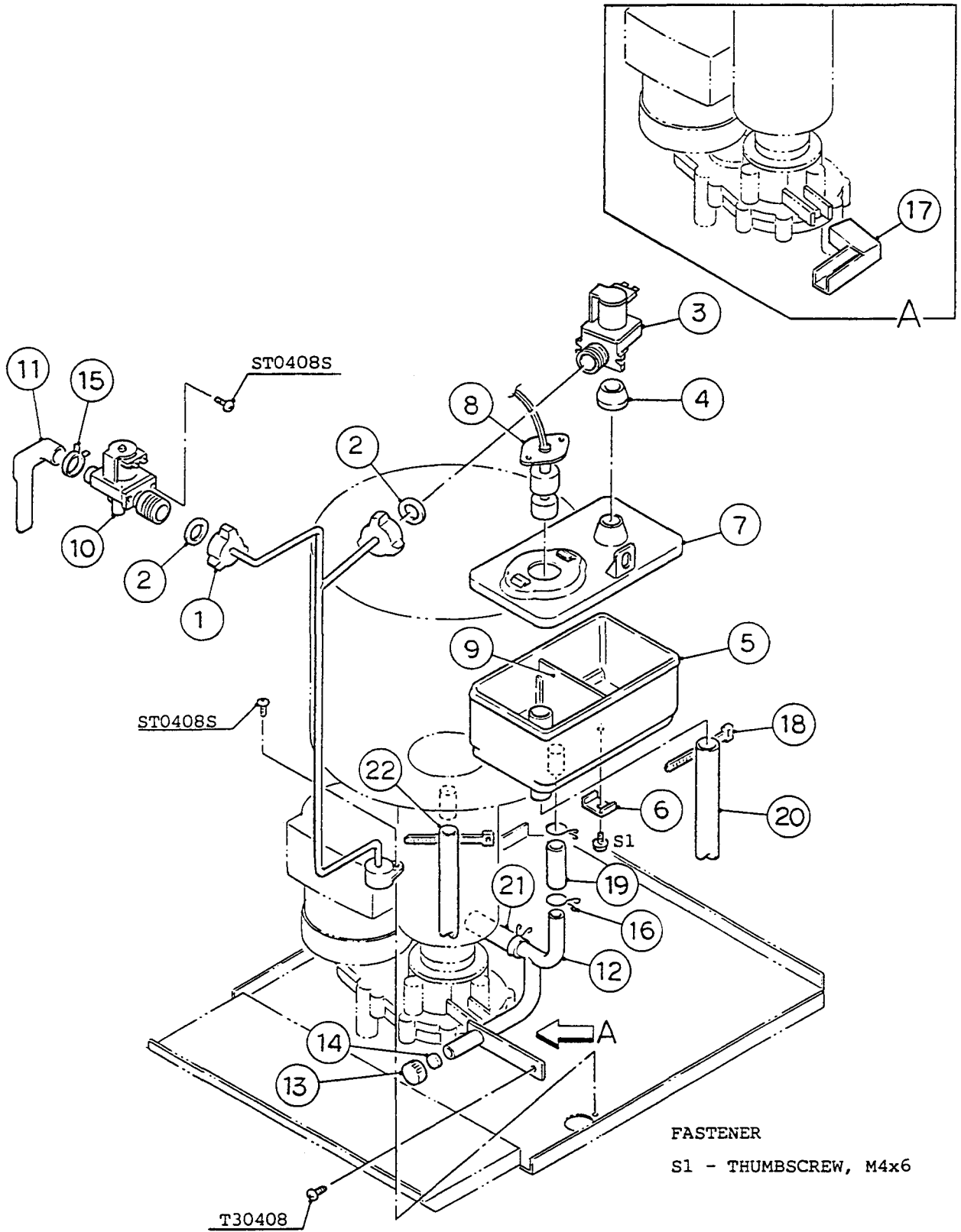

HA

MODEL: DCM-240BAB TITLE: D. WATER CIRCUIT							
INDEX NO.	DESCRIPTION	MATERIAL OR MODEL NUMBER	PART NUMBER	REQD NUMBER			
				A-1	A-2	B-0	B-1
1	PIPE-WATER SUPPLY	S.S.	319700G01	1	1	1	1
2	PACKING	NBR	413854-03	2	2	2	2
3	WATER VALVE	J246-086	3U0065-01	1	1	1	1
4	COVER - RESERVOIR INLET	SI RUBBER	415094-01	1	1	1	1
5	RESERVOIR	ABS	207527-02	1	1	1	1
6	COLLAR	S.S	423416-01	1	1	1	1
7	COVER - RESERVOIR	ABS	103070-02	1	1	1	1
8	FLOAT SWITCH	TW-1221-101	435490-01	1	1	1	1
9	SEPARATOR - RESERVOIR	ABS	423538-01	1	1	1	1
10	WATER VALVE	J246-317	3U0066-01	1	1	1	1
11	PIPE - WATER SUPPLY	SI RUBBER	427618-01	1	1	1	1
		SI RUBBER	427618-02	1	1	1	1
12	PIPE - JOINT	S.S	319701G01	1	1	1	1
13	CAP - DRAIN	BRASS	425629-01	1	1	1	1
14	PACKING - DRAIN	SY.R	418071-03	1	1	1	1
15	CLAMP	HB20T19	423866-02	1	1	1	1
16	CLAMP	SK-14	435934-02	4	4	4	4
17	PIPE - DRAIN	EPDM	429620-01	1	1	1	1
18	TIE	CV-150	7920-0003	2	2	2	2
19	SILICONE HOSE	7730-1114,L=45	105416-01	1	1	1	1
20	SILICONE HOSE	7730-1721, L=250	105416-23	1	1	1	1
21	HOSE	7716-1216,L=70	105416-22	1	1	1	1
22	HOSE	7716-1216, L=350	105416-24	1	1	1	1

HA

MODEL: DCM-240BAB TITLE: D. WATER CIRCUIT							
INDEX NO.	DESCRIPTION	MATERIAL OR MODEL NUMBER	PART NUMBER	REQ'D NUMBER			
				B-2	B-3	C-1	C-2
1	PIPE - WATER SUPPLY	S.S	319700G01	1	1	1	1
2	PACKING	NBR	413854-03	2	2	2	2
3	WATER VALVE	J246-086	3U0065-01	1	1	1	1
4	COVER - RESERVOIR INLET	SI RUBBER	415094-01	1	1	1	1
5	RESERVOIR	ABS	207527-02	1	1	1	1
6	COLLAR	S.S	423416-01	1	1	1	1
7	COVER - RESERVOIR	ABS	103070-02	1	1	1	1
8	FLOAT SWITCH	TW-1221-101	435490-01	1	1	1	1
9	SEPARATOR - RESERVOIR	ABS	423538-01	1	1	1	1
10	WATER VALVE	J246-317	3U0066-01	1	1	1	1
11	PIPE-WATER SUPPLY	SI RUBBER	427618-02	1	1	1	1
12	PIPE - JOINT	S.S	319701G01	1	1	1	1
13	CAP - DRAIN	BRASS	425629-01	1	1	1	1
14	PACKING - DRAIN	SY.R	418071-03	1	1	1	1
15	CLAMP	HB20T19	423866-02	1	1	1	1
16	CLAMP	SK-14	435934-02	4	4	4	4
17	PIPE - DRAIN	EPDM	429620-01	1	1	1	1
18	TIE	CV-150	7920-0003	2	2	2	2
19	SILICONE HOSE	7730-1114,L=45	105416-01	1	1	1	1
20	SILICONE HOSE	7730-1721, L=250	105416-23	1	1	1	1
21	HOSE	7730-1114, L= 70	105416-22	1	1	1	1
22	HOSE	7716-1216, L=350	105416-24	1	1	1	1

HA
DCM-240BAB

E. CONTROL BOX (A) ASSY

(C-1) (C-2)
(B-1) (B-2) (B-3)
(B-0) (A-1) (A-2)

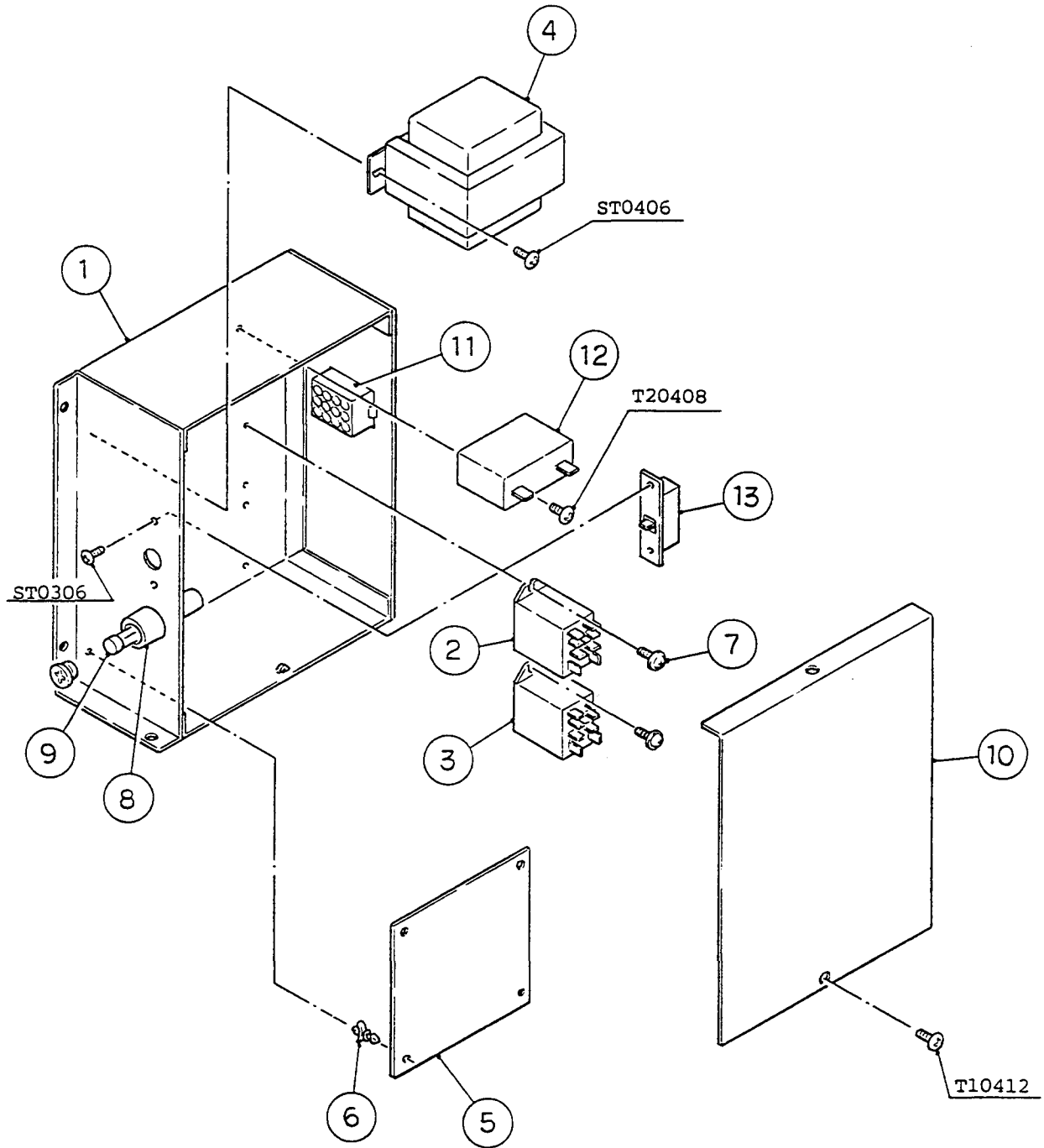

HA

MODEL: DCM-240BAB TITLE: E. CONTROL BOX (A) ASSY							
INDEX NO.	DESCRIPTION	MATERIAL OR MODEL NUMBER	PART NUMBER	REQD NUMBER			
				A-1	A-2	B-0	B-1
1	CONTROL BOX (A)	G.S	327132G01	1	1	1	1
2	RELAY	LY2FZ, AC24V	406132-06	1	1	1	1
3	RELAY	LY1F.AC120V	418271-03	1	1	1	1
4	TRANSFORMER	TR5267	2U0042-01	1	1	1	1
5	TIMER BOARD	H2AA144C02	437305-02	1	1	1	1
6	BOARD SUPPORT	KGLS-6S	414929-01	4	4	4	4
7	TAPPING SCREW	3x8	431415-01	4	4	4	4
8	FUSE HOLDER	FH032, 250V10A	424288-01	1	1	1	1
9	FUSE	FGA02.1A250V	420468-03	1	1	1	1
10	COVER - CONTROL BOX (A)	G.S	440900-01	1	1	1	1
11	PLUG	3191-12P	412832-04	1	1	1	1
12	CAPACITOR	280VAC, 10UuF	416921-05	1	1	1	1
13	OVERLOAD- GEAR MOTOR	NW-3P-2	427253-01	1	1	1	1

HA

MODEL: DCM-240BAB TITLE: E. CONTROL BOX (A) ASSY							
INDEX NO.	DESCRIPTION	MATERIAL OR MODEL NUMBER	PART NUMBER	REQ'D NUMBER			
				B-2	B-3	C-1	C-2
1	CONTROL BOX (A)	G.S	327132G01	1	1	1	1
2	RELAY	LY2FZ, AC24V	406132-06	1	1	1	1
3	RELAY	LY1F.AC120V	418271-03	1	1	1	1
4	TRANSFORMER	TR5267	2U0042-01	1	1	1	1
5	TIMER BOARD	H2AA144C02	437305-02	1	1	1	1
6	BOARD SUPPORT	KGLS-6S	414929-01	4	4	4	4
7	TAPPING SCREW	3x8	431415-01	4	4	4	4
8	FUSE HOLDER	FH032, 250V10A	424288-01	1	1	1	1
9	FUSE	FGA02, 1A250V	420468-03	1	1	1	1
10	COVER - CONTROL BOX (A)	G.S	440900-01	1	1	1	1
11	PLUG	3191-12P	412832-04	1	1	1	1
12	CAPACITOR	280VAC, 10UuF	416921-05	1	1	1	1
13	OVERLOAD- GEAR MOTOR	NW-3P-2	427253-01	1	1	1	1

HA
DCM-240BAB

F. CONTROL BOX (B) ASSY

(C-1) (C-2)
(B-1) (B-2) (B-3)
(B-0) (A-1) (A-2)

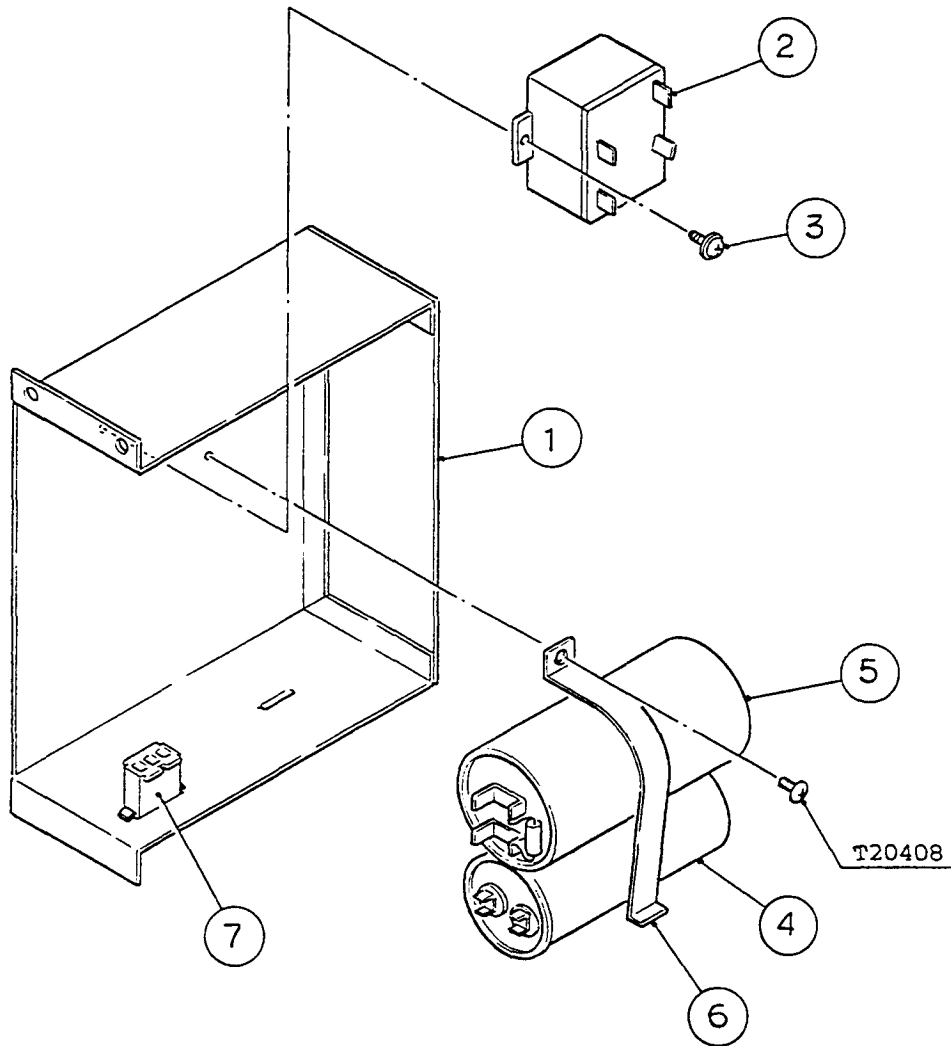

HA

MODEL: DCM-240BAB TITLE: F. CONTROL (B) BOX ASSY							
INDEX NO.	DESCRIPTION	MATERIAL OR MODEL NUMBER	PART NUMBER	REQD NUMBER			
				A-1	A-2	B-0	B-1
1	CONTROL BOX (B)	G.S	327129G01	1	1	1	1
2	STARTER	AMVL-180BF	440251-02	1	1	1	1
3	TAPPING SCREW	3x8	431415-01	1	1	1	1
4	RUN CAPACITOR	PMT-33300P	428391-02	1	1	1	1
5	START CAPACITOR	MS240F100(J)-R	426901 -01	1	1	1	1
6	STRAP- CAPACITOR	G.S	432425-01	1	1	1	1
7	3P PLUG HOUSING	3191-03P	412832-06	1	1	1	1

HA

MODEL: DCM-240BAB TITLE: F. CONTROL (B) BOX ASSY							
INDEX NO.	DESCRIPTION	MATERIAL OR MODEL NUMBER	PART NUMBER	REQD NUMBER			
				B-2	B-3	C-1	C-2
1	CONTROL BOX (B)	G.S	327129G01	1	1	1	1
2	STARTER	AMVL-180BF	440251-02	1	1	1	1
3	TAPPING SCREW	3x8	431415-01	1	1	1	1
4	RUN CAPACITOR	PMT-33300P	428391-02	1	1	1	1
5	START CAPACITOR	MS240F100(J)-R	426901-01	1	1	1	1
6	STRAP- CAPACITOR	G.S	432425-01	1	1	1	1
7	3P PLUG HOUSING	3191-03P	412832-06	1	1	1	1

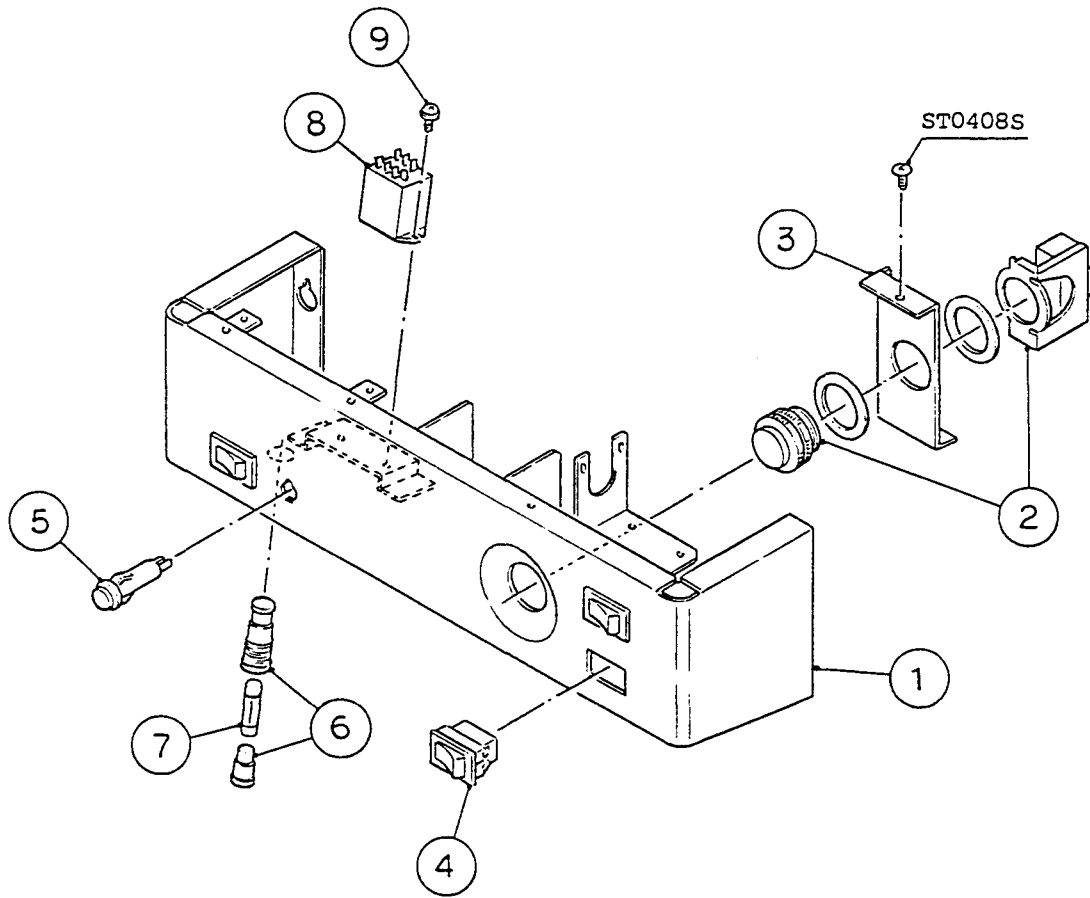

HA

MODEL: DCM-240BAB		TITLE: G. MIDDLE FRONT PANEL ASSY					
INDEX NO.	DESCRIPTION	MATERIAL OR MODEL NUMBER	PART NUMBER	REQD NUMBER			
				A-1	A-2	B-0	B-1
1	MIDDLE FRONT PANEL	S.S	216344G01	1	1	1	1
2	PUSH SW.	ZAP-1B	435745-02	1	1	1	1
3	SW.BRACKET	S.S	440437-01	1	1	1	1
4	ROCKER SWITCH	HLS112A	421490-01	4	4	4	4
5	LAMP	A107P-RFN	423965-01	1	1	1	1
6	FUSE HOLDER	PFP9090-0101	440464-01	1	1	1	1
7	FUSE	314015.15A250V	420468-05	1	1	1	1
8	RELAY	LY1F.AC120V	418271-03	1	1	1	1
9	TAPPING SCREW	3x8	431415-01	2	2	2	2

HA

MODEL: DCM-240BAB TITLE: G. MIDDLE FRONT PANEL ASSY							
INDEX NO.	DESCRIPTION	MATERIAL OR MODEL NUMBER	PART NUMBER	REQD NUMBER			
				B-2	B-3	C-1	C-2
1	MIDDLE FRONT PANEL	S.S	216344G01	1	1	1	1
2	PUSH SW.	ZAP-1B	435745-02	1	1	1	1
3	SW.BRACKET	S.S	440437-01	1	1	1	1
4	ROCKER SWITCH	HLS112A	421490-01	4	4	4	4
5	LAMP	A107P-RPN	423965-01	1	1	1	-
		621 T-2	446400-01				1
6	FUSE HOLDER	PFP9090-0101	440464-01	1	1	1	1
7	FUSE	314015.15A250V	420468-05	1	1	1	1
8	RELAY	LY1F.AC120V	418271-03	1	1	1	1
9	TAPPING SCREW	3x8	431415-01	2	2	2	2

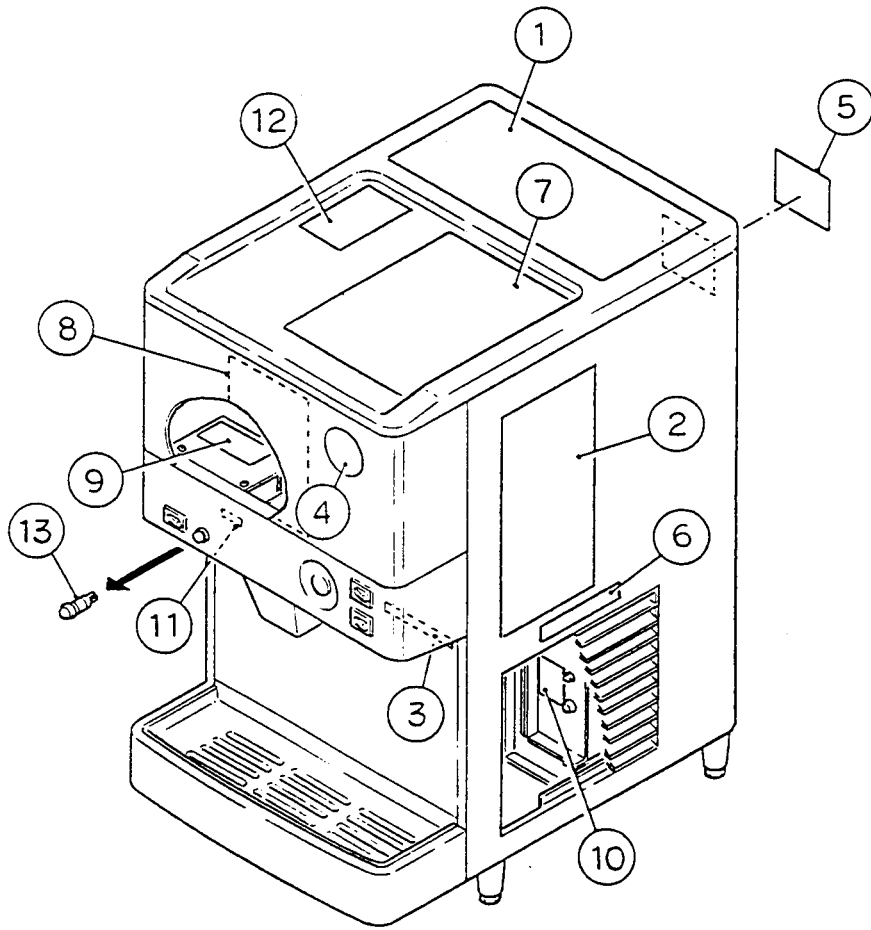

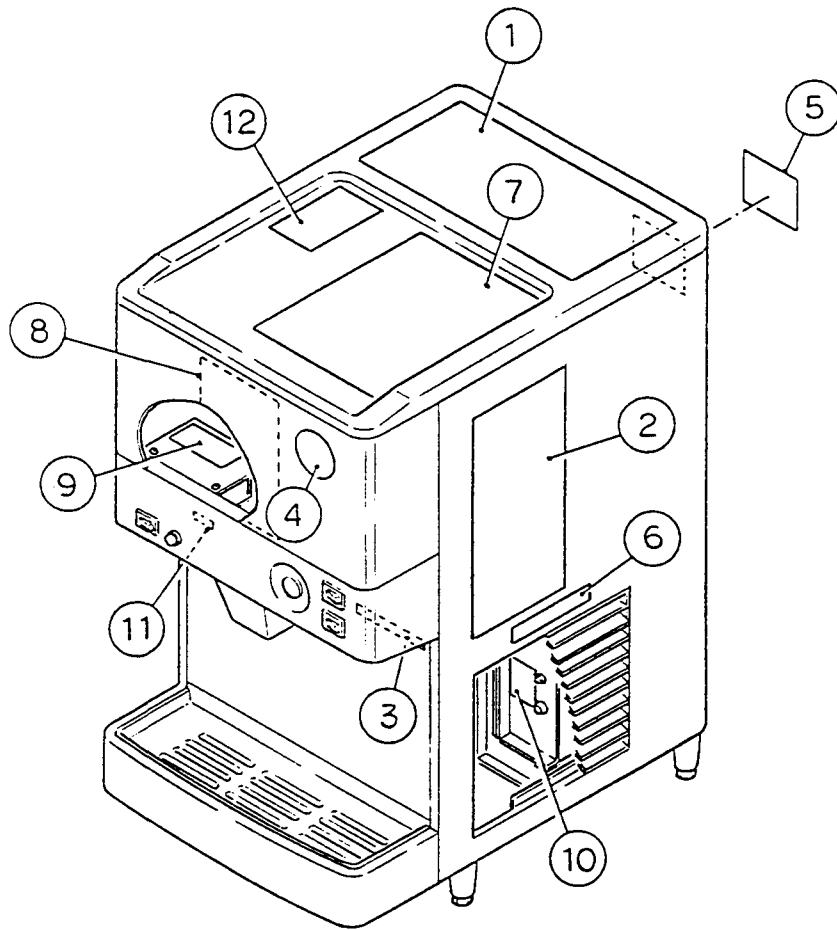

HA

MODEL: DCM-240BAB TITLE : H. LABEL LOCATION							
INDEX NO.	DESCRIPTION	MATERIAL OR MODEL NUMBER	PART NUMBER	REQD NUMBER			
				A-1	A-2	B-0	B-1
1	INSTRUCTION SHEET	PAPER	216397-01	1	1	1	1
2	INSTRUCTION LABEL	PES	216398-01	1	1	1	1
3	MODEL NUMBER LABEL	PES	435985-23	1	1	1	1
4	LABEL - PENGUIN	PETP FILM	423949-01	1	1	1	1
5	NAMEPLATE	PES FILM	440925-01	1	1	1	1
6	LABEL-AIR FILTER	PETP FILM	426177-01	1	1	1	1
7	LABEL-CLEANING	PETP FILM	216399-01	1	1	1	1
8	WIRING LABEL	PVC FILM	327195-01	1	1	1	1
9	RATING LABEL	PES FILM	440926-01	1	1	1	1
10	LABEL - RESET	PETP FILM	435319-01	1	1	1	1
11	LABEL-FUSE (15A)	PETP FILM	425324-03	1	1	1	1
12	CAUTION LABEL	PVC FILM	441560-01	1	1	1	1
13	LABEL - LAMP	PAPER	427602-01	1	1	1	1

HA

MODEL: DCM-240BAB TITLE: H. LABEL LOCATION							
INDEX NO.	DESCRIPTION	MATERIAL OR MODEL NUMBER	PART NUMBER	REQD NUMBER			
				B-2	B-3	C-1	C-2
1	INSTRUCTION SHEET	PAPER	216397-01	1	1	1	1
2	INSTRUCTION LABEL	PES	216398-01	1	1	1	1
3	MODEL NUMBER LABEL	PES	435985-23	1	1	1	1
4	LABEL-PENGUIN	PETP FILM	423949-01	1	1	1	1
5	NAMEPLATE	PES FILM	440925-01	1	1	1	1
6	LABEL - AIR FILTER	PETP FILM	426177-01	1	1	1	1
7	LABEL - CLEANING	PETP FILM	216399-01	1	1	1	1
8	WIRING LABEL	PVC FILM	327195-01	1	1	1	1
9	RATING LABEL	PES FILM	440926-01	1	1	1	1
10	LABEL - RESET	PETP FILM	435319-01	1	1	1	1
11	LABEL-FUSE (15A)	PETP FILM	425324-03	1	1	1	1
12	CAUTION LABEL	RVC FILM	441560-01	1	1	1	1
13	LABEL - LAMP	PAPER	427602-01	1	1	1	-

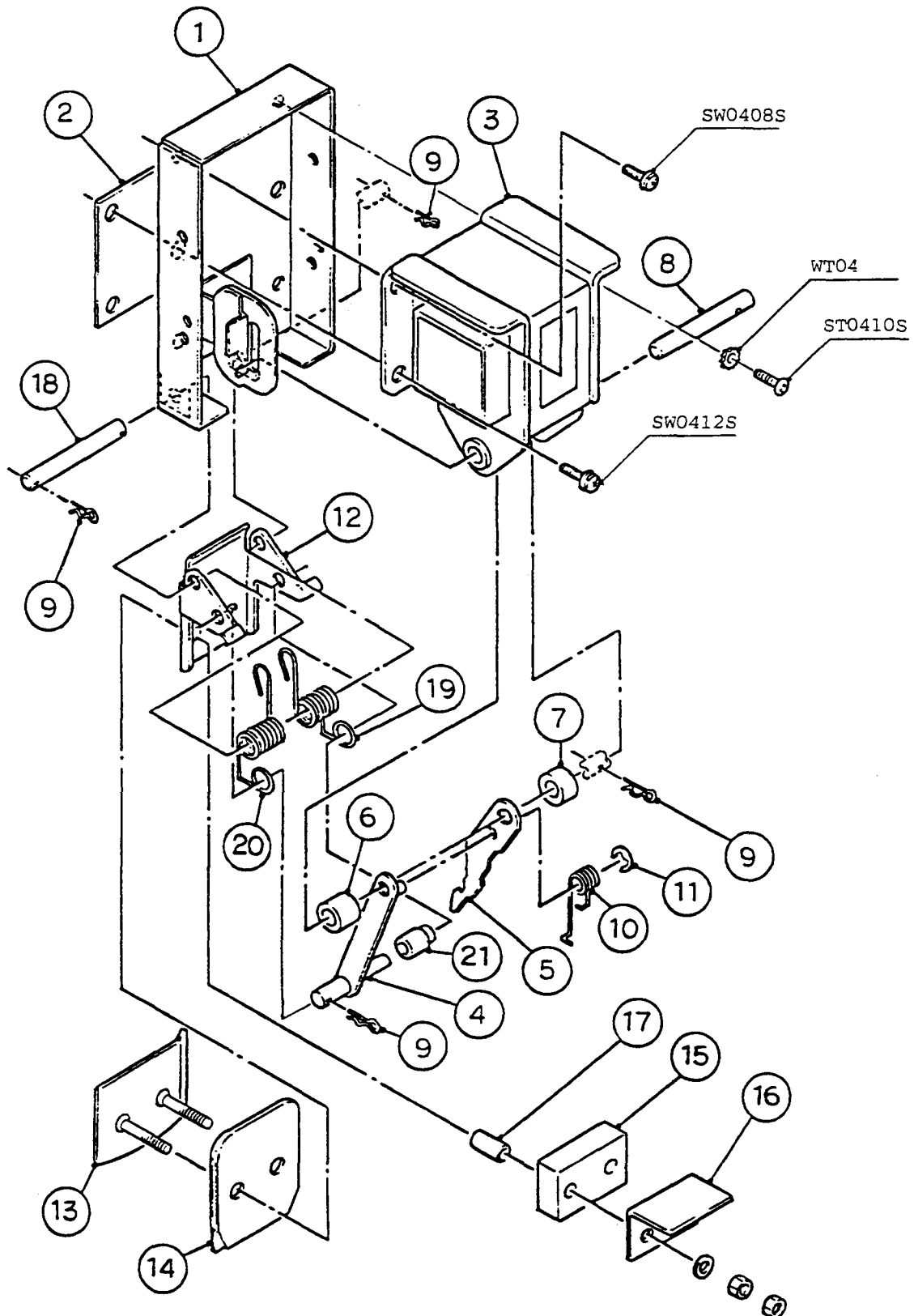

HA
DCM-240BAB

J. SHUTTER ASSY

(C-2)
(C-1) (B-2) (B-3)
(B-1) (B-0) (A-2)

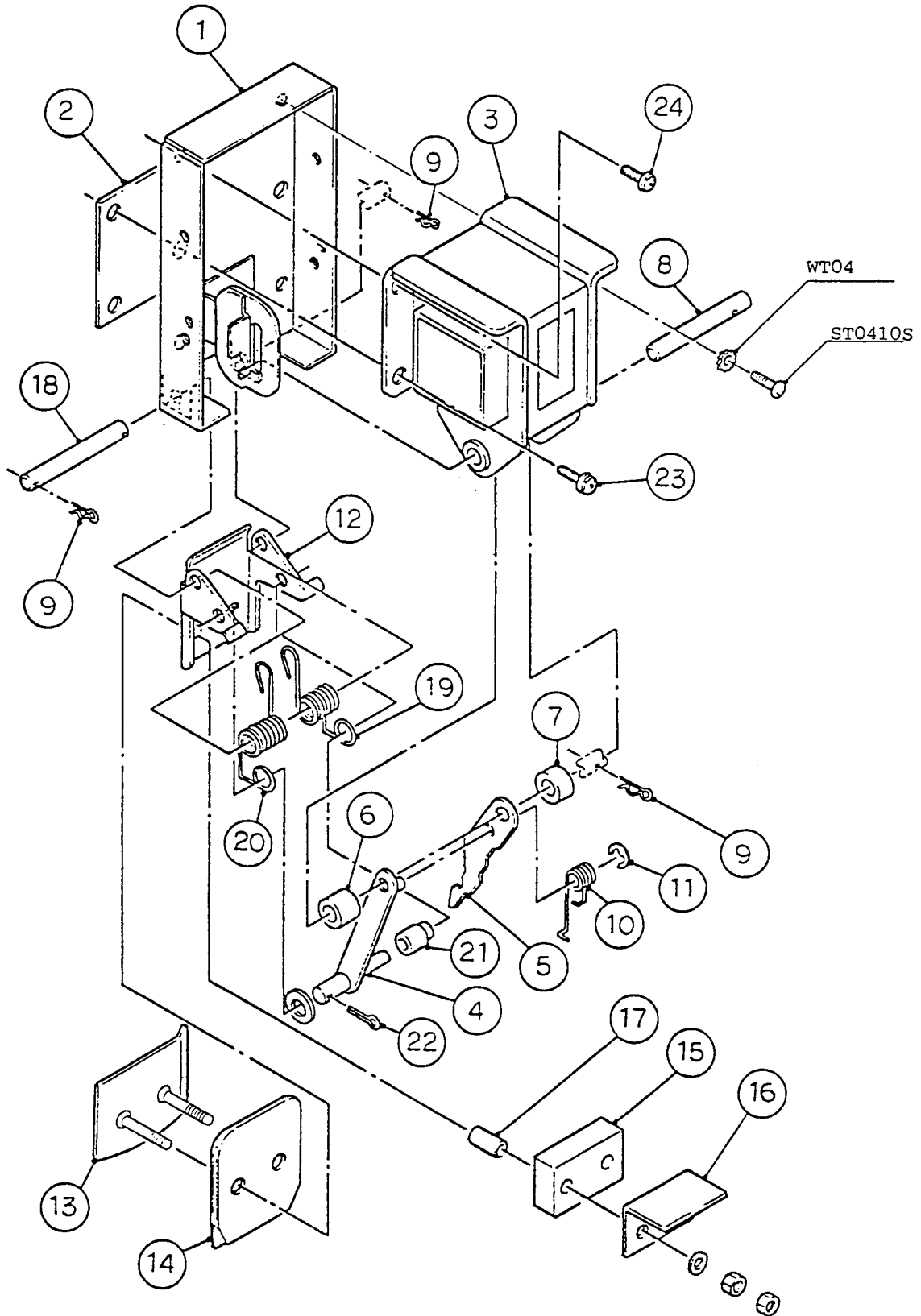

HA

MODEL: DCM-240BAB TITLE: J. SHUTTER ASSY							
INDEX NO.	DESCRIPTION	MATERIAL OR MODEL NUMBER	PART NUMBER	REQD NUMBER			
				A-1	A-2	B-0	B-1
1	BRACKET-SOLENOID	S.S	320896G02	1	1	1	1
2	SPACER	ABS	432514-01	1	1	1	1
3	SOLENOID	AS-20-N075	437926-01	1	1	1	1
4	SHAFT	S.S	433088G02	1	-		
		S.S	441645G01		1	1	1
5	HOOK-SHUTTER	S.S	438406-01	1	1	1	1
6	COLLAR (A)	ABS	432524-01	1	1	1	1
7	COLLAR (B)	ABS	432524-02	1	1	1	1
8	SHAFT (A) - SOLENOID	S.S	432517-02	1	1	1	1
9	SNAP PIN	S.S, SSP-5	715S-0005	4	3	3	3
10	SPRING	S.S	411532-01	1	1	1	1
11	"E" RING	S.S, 4	721 S-0004	1	1	1	1
12	STOPPER	S.S	432518-03	1	1	1	1
13	PLATE (A) - SHUTTER	S.S	423946G01	1	1	1	1
14	PLATE (B)-SHUTTER	EPDM	423948-01	1	1	1	1
15	PLATE(C) - SHUTTER	SY. R FOAM	419150-01	1	1	1	1
16	PLATE(D) - SHUTTER	S.S	419151-01	1	1	1	1
17	COLLAR (C)-SHUTTER	S.S	411539-03	2	2	2	2
18	SHAFT (A)	S.S	432523-01	1	1	1	1
19	SPRING (RIGHT)	S.S	434478-01	1	1	1	1
20	SPRING (LEFT)	S.S	434479-01	1	1	1	1
21	SHAFT(B2)	S.S	432520-02	1	1	1	1
22	SPLIT PIN	S.S, 1.6x15	711SP1615		1	1	1
23	SCREW	S.S, 4x12	434838-02		4	4	4
24	SCREW	S.S, 4x8	434838-01		1	1	1

HA

MODEL: DCM-240BAB TITLE: J. SHUTTER ASSY							
INDEX NO.	DESCRIPTION	MATERIAL OR MODEL NUMBER	PART NUMBER	REQD NUMBER			
				B-2	B-3	C-1	C-2
1	BRACKET - SOLENOID	S.S	320896G02	1	1	1	1
2	SPACER	ABS	432514-01	1	1	1	1
3	SOLENOID	AS-20-N075	437926-01	1	1	1	1
4	SHAFT	S.S	441645G01	1	1	1	1
5	HOOK-SHUTTER	S.S	438406-01	1	1	1	1
6	COLLAR (A)	ABS	432524-01	1	1	1	1
7	COLLAR (B)	ABS	432524-02	1	1	1	1
8	SHAFT (A) - SOLENOID	S.S	432517-02	1	1	1	1
9	SNAP PIN	S.S, SSP-5	715S-0005	4	3	3	3
10	SPRING	S.S	411532-01	1	1	1	1
11	-E" RING	S.S, 4	721 S-0004	1	1	1	1
12	STOPPER	S.S	432518-03	1	1	1	1
13	PLATE (A) - SHUTTER	S.S	423946G01	1	1	1	1
14	PLATE (B) - SHUTTER	EPDM	423948-01	1	1	1	1
15	PLATE (C) - SHUTTER	SY. R FOAM	419150-01	1	1	1	1
16	PLATE (D) - SHUTTER	S.S	419151-01	1	1	1	1
17	COLLAR (C) - SHUTTER	S.S	411539-03	2	2	2	2
18	SHAFT (A)	S.S	432523-01	1	1	1	1
19	SPRING (RIGHT)	S.S	434478-01	1	1	1	1
20	SPRING (LEFT)	S.S	434479-01	1	1	1	1
21	SHA FT (B2)	S.S	432520-02	1	1	1	1
22	SPLIT PIN	S.S, 1.6x15	711SP1615	1	1	1	1
23	SCREW	S.S, 4x12	434838-02	4	4	4	4
24	SCREW	S.S, 4x8	434838-01	1	1	1	1

HA
DCM-240BAB

K. COVER ASSY - BIN TOP

	(C-1)	(C-2)
(B-1)	(B-2)	(B-3)
(B-0)	(A-1)	(A-2)

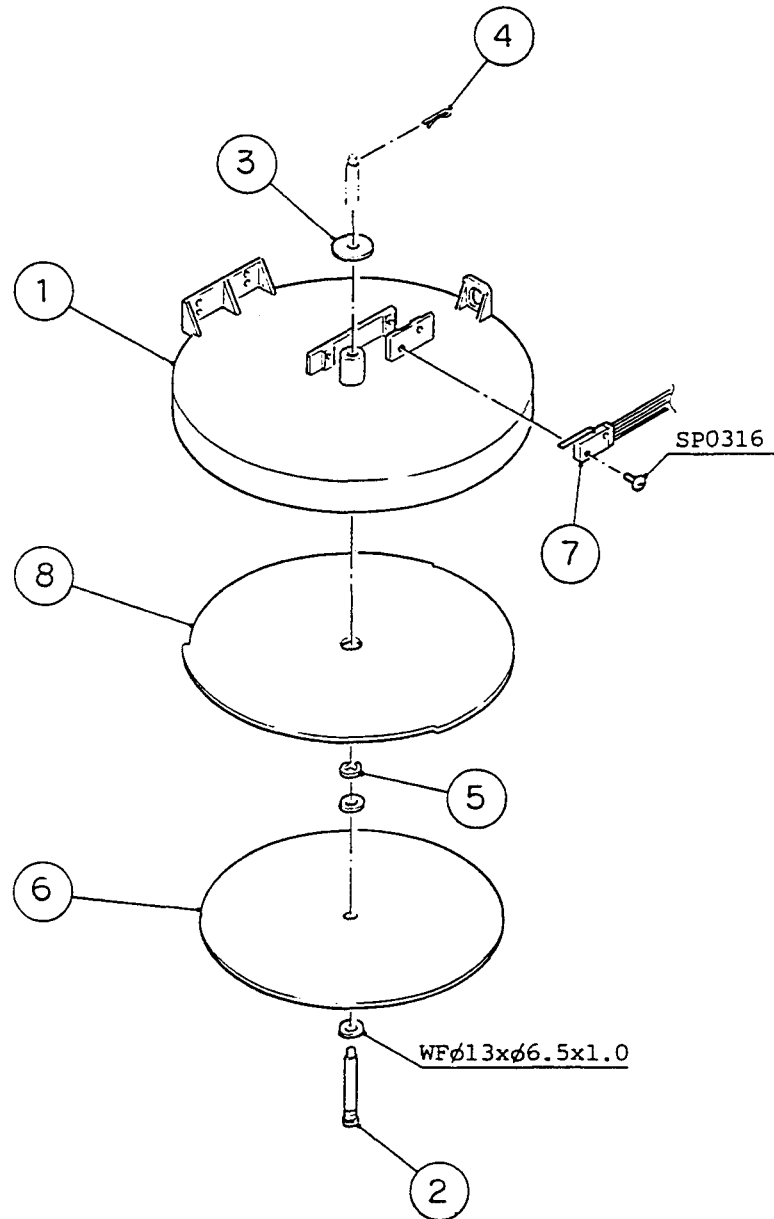

HA

MODEL: DCM-240BAB TITLE: K. COVER ASSY - BIN TOP							
INDEX NO.	DESCRIPTION	MATERIAL OR MODEL NUMBER	PART NUMBER	REQD NUMBER			
				A-1	A-2	B-0	B-1
1	COVER - BIN TOP	ABS	103829G01	1	1	1	1
2	SHAFT	S.S	423958-01	1	1	1	1
3	BALANCE PLATE	S.S	423959-01	1	1	1	1
4	SNAP PIN	S.S, SSP-4	715S-0004	1	1	1	1
5	"E" RING	S.S	721 S-0005	1	1	1	1
6	BALANCE PLATE	ABS	417473-02	1	1	1	1
7	MICROSWITCH	V-5L11155W	423950-01	1	1	1	1
8	INSIDE PLATE	ABS	207830-01	1	1	1	1

HA

MODEL: DCM-240BAB		TITLE: K. COVER ASSY - BIN TOP					
INDEX NO.	DESCRIPTION	MATERIAL OR MODEL NUMBER	PART NUMBER	REQD NUMBER			
				B-2	B-3	C-1	C-2
1	COVER - BIN TOP	ABS	103829G01	1	1	1	1
2	SHAFT	S.S	423958-01	1	1	1	1
3	BALANCE PLATE	S.S	423959-01	1	1	1	1
4	SNAP PIN	S.S, SSP-4	715S-0004	1	1	1	1
5	"E" RING	S.S	721 S-0005	1	1	1	1
6	BALANCE PLATE	ABS	417473-02	1	1	1	1
7	MICROSWITCH	V-5L11155W	423950-01	1	1	1	1
8	INSIDE PLATE	ABS	207830-01	1	1	1	1

HA
DCM-240BAB

L. FAN MOTOR ASSY

(C-1) (C-2)
(B-1) (B-2) (B-3)
(B-0) (A-1) (A-2)

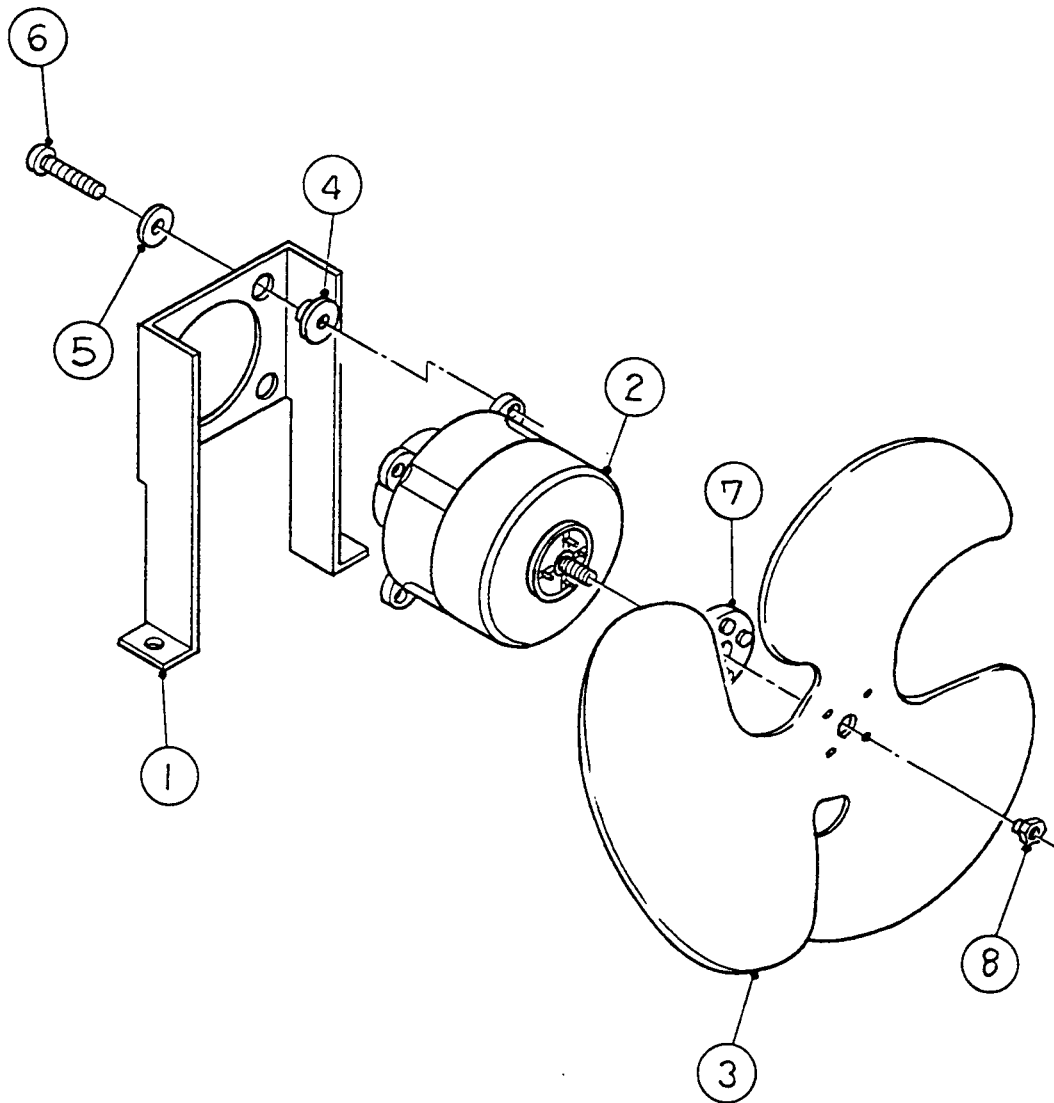

HA

MODEL: DCM-240BAB TITLE: L. FAN MOTOR ASSY							
INDEX NO.	DESCRIPTION	MATERIAL OR MODEL NUMBER	PART NUMBER	REQD NUMBER			
				A-1	A-2	B-0	B-1
1	BRACKET (B) - FAN MOTOR	G.S	307282-02	1	1	1	1
2	FAN MOTOR	EK-TZ2	2U0005-01	1	1	1	1
3	FAN BLADE	0230, ALUMINIUM	414392-01	1	1	1	1
4	GROMMET (A)	-	414390F01	4	4	4	4
5	WASHER-GROMMET	-	414390F03	8	8	8	8
6	SCREW	-	414390F05	4	4	4	4
7	PAD	-	414390F06	1	1	1	1
8	NUT	-	414390F07	1	1	1	1

HA

MODEL: DCM-240BAB		TITLE: L. FAN MOTOR ASSY					
INDEX NO.	DESCRIPTION	MATERIAL OR MODEL NUMBER	PART NUMBER	REQD NUMBER			
				B-2	B-3	C-1	C-2
1	BRACKET (B) - FAN MOTOR	G.S	307282-02	1	1	1	1
2	FAN MOTOR	EK-TZ2	2U0005-01	1	1	1	1
3	FAN BLADE	0230, ALUMINIUM	414392-01	1	1	1	1
4	GROMMET(A)	-	414390F01	4	4	4	4
5	WASHER-GROMMET	-	414390F03	8	8	8	8
6	SCREW	-	414390F05	4	4	4	4
7	PAD	-	414390F06	1	1	1	1
8	NUT	-	414390F07	1	1	1	1

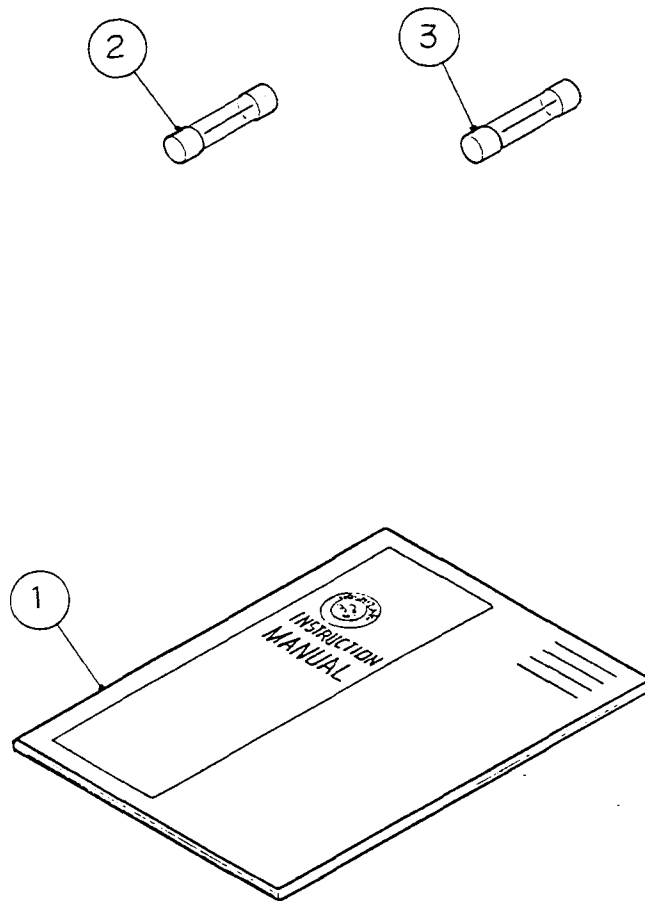

HA

MODEL: DCM-240BAB TITLE: M. ACCESSORIES							
INDEX NO.	DESCRIPTION	MATERIAL OR MODEL NUMBER	PART NUMBER	REQD NUMBER			
				A-1	A-2	B-0	B-1
1	INSTRUCTION MANUAL	PAPER	91U2GR10A	1	1	1	1
2	FUSE	FGA02, 1A250V	420468-03	1	1	1	1
3	FUSE	314015.15A250V	420468-05	1	1	1	1

HA

MODEL: DCM-240BAB TITLE: M. ACCESSORIES							
INDEX NO.	DESCRIPTION	MATERIAL OR MODEL NUMBER	PART NUMBER	REQ'D NUMBER			
				B-2	B-3	C-1	C-2
1	INSTRUCTION MANUAL	PAPER	91U2GR10A	1	1	1	1
2	FUSE	FGA02, 1A250V	420468-03	1	1	1	1
3	FUSE	314015.15A250V	420468-05	1	1	1	1

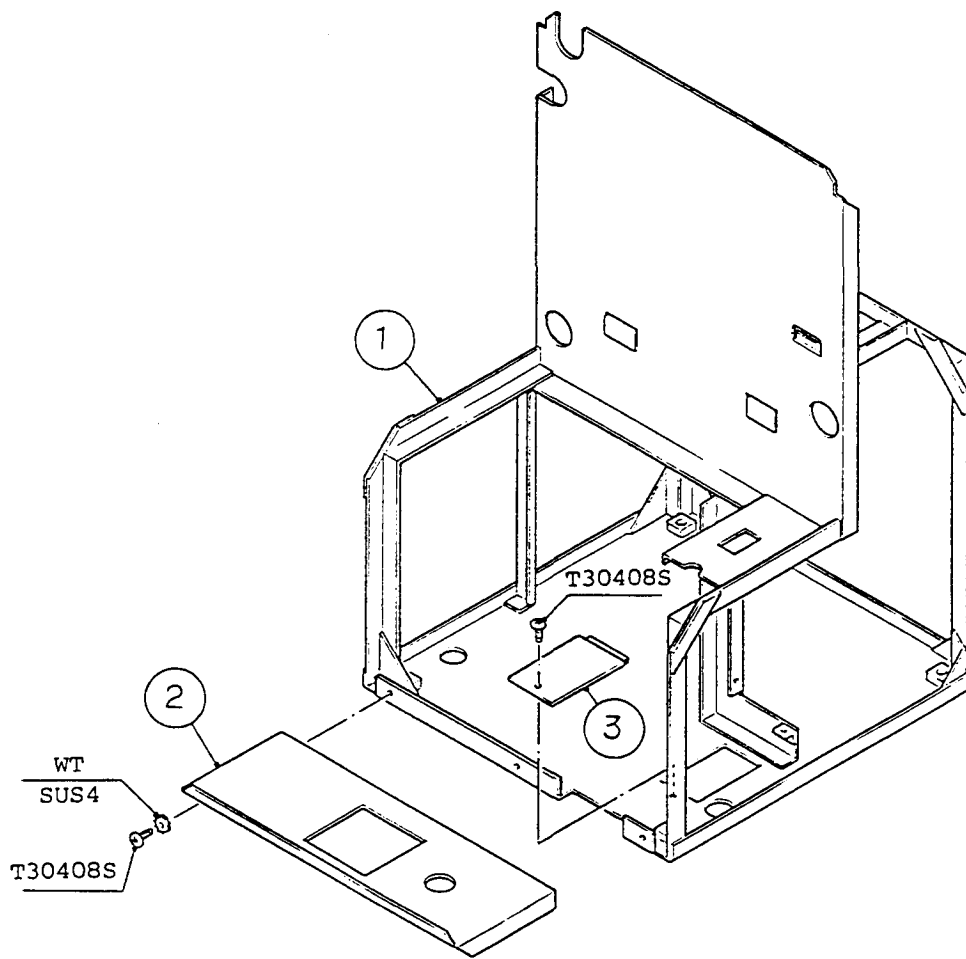

HA

MODEL: DCM-240BAB TITLE: N. FRAME							
INDEX NO.	DESCRIPTION	MATERIAL OR MODEL NUMBER	PART NUMBER	REQ'D NUMBER			
				A-1	A-2	B-0	B-1
1	FRAME (A)	G.S	106030G01				1
2	FRAME (B)	G.S	329483-01				1
3	COVER - CHASSIS	G.S	436917-01				1

HA

MODEL: DCM-240BAB TITLE: N. FRAME							
INDEX NO.	DESCRIPTION	MATERIAL OR MODEL NUMBER	PART NUMBER	REQD NUMBER			
				B-2	B-3	C-1	C-2
1	FRAME (A)	G.S	106030G01	1	1	1	1
2	FRAME (B)	G.S	329483-01	1	1	1	1
3	COVER - CHASSIS	G.S	436917-01	1	1	1	1