



**HOSHIZAKI**

**CUBELET ICE DISPENSER**

MODEL

**DCM-240BAE**

**PARTS LIST**

ISSUED: FEB. 08. 1994

REVISED: JUL. 04. 1994

PRINTED: APR. 14, 1995 ITEM

NO: 71098 \_\_\_\_\_

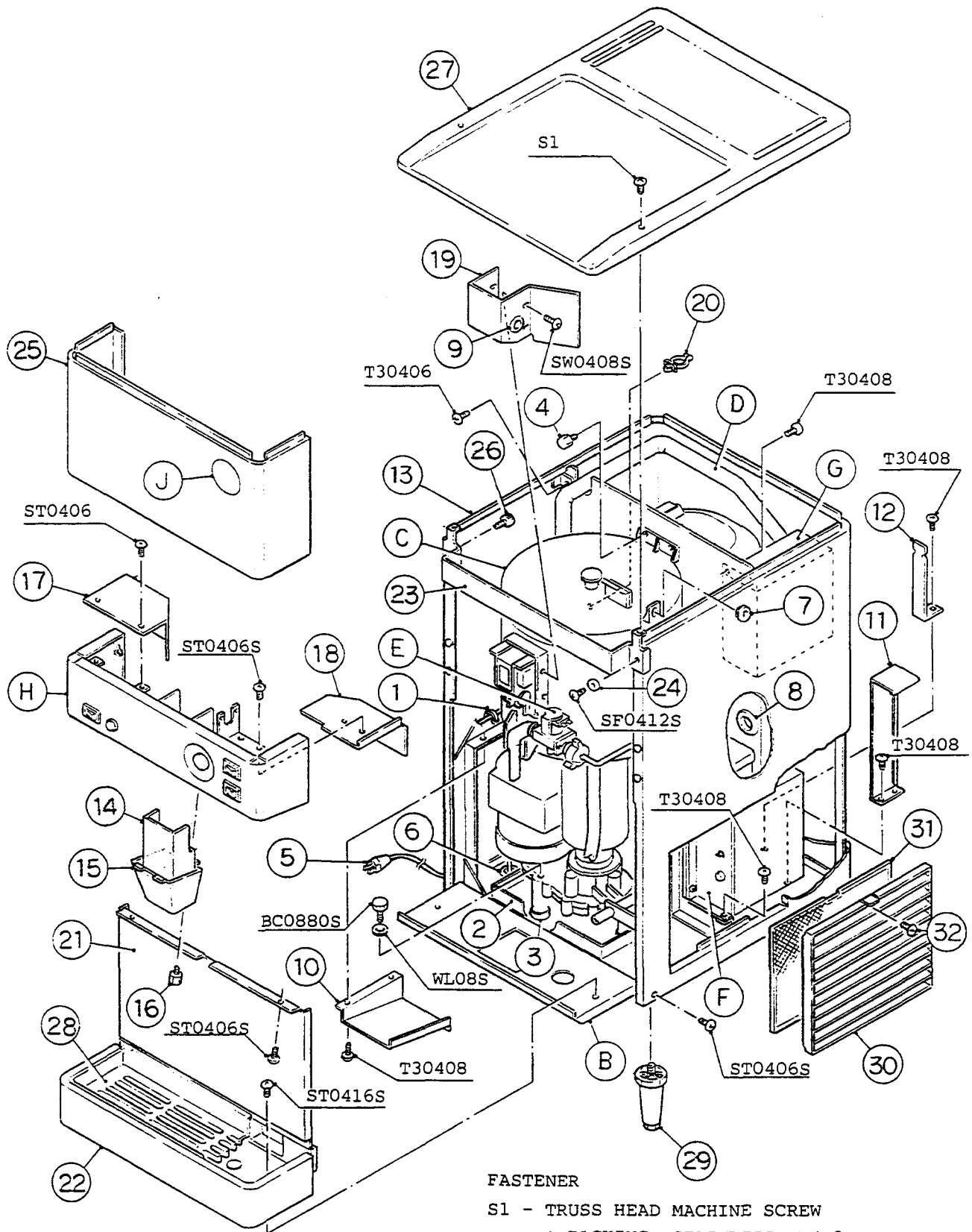

MODEL: DCM-240BA E TITLE: A. ICE DISPENSER ASSY							
INDEX NO.	DESCRIPTION	MATERIAL OR MODEL NUMBER	PART NUMBER	REQ'D NUMBER			
				D-1			
B	FRAME ASSY	--	106825A02	1			
C	ICE MAKING UNIT	--	220559A02	1			
D	REFRIGERATION CIRCUIT	--	106827A01	1			
E	WATER CIRCUIT	--	105416A02	1			
F	CONTROL BOX (A)	--	332587A01	1			
G	CONTROL BOX (B)	--	332588A01	1			
H	MIDDLE FRONT PANEL ASSY	--	332787A01	1			
J	LABEL LOCATION	--	332589A01	1			
1	TIE	CV-100	7920-0002	7			
2	DRAIN PAN	s.s	446639-01	1			
3	SPACER	PVC	440956-01	3			
4	THUMBSCREW	S.S, ABS	415949G04	2			
5	POWER SUPPLY CORD	KP-30B	421824-01	1			
6	BUSHING	SR-7K-2	420472-02	1			
7	BUSHING	SR-30-1	420472-03	2			
8	BUSHING	SB-1500-21	420470-06	2			
9	BUSHING	SB-625-8	420470-01	1			
10	BARRIER - GEAR MOTOR	G.S	446634-01	1			
11	BARRIER	G.S	446640-01	1			
12	HOLDER - ACCESS VALVE	G.S	446641-01	1			
13	CABINET	S.S	424987G13	1			
14	SPOUT (A)	ABS	105409-01	1			
15	SPOUT (B)	ABS	105410-01	1			
16	THUMBSCREW	ABS, S.S	415949G08	1			
17	FRONT BARRIER (L)	G.S	425094-01	1			
18	FRONT BARRIER (R)	G.S	446642-01	1			
19	BARRIER - SOLENOID	S.S	446692-01	1			
20	CLAMP	N0.4253	427902-05	1			
21	APRON PANEL	S.S	327163-01	1			
22	DRAIN PAN	ABS	318857G03	1			
23	BRACKET	G.S	424988-02	1			

MODEL: DCM-240BAE TITLE: A. ICE DISPENSER ASSY							
INDEX NO.	DESCRIPTION	MATERIAL OR MODEL NUMBER	PART NUMBER	REQ'D NUMBER			
				D-1			
24	COLLAR	S.S	4H0171-01	1			
25	FRONT PANEL	S.S	216359G03	1			
26	THUMBSCREW	S.S	425221-01	1			
27	TOP PANEL (E)	G.S	104679-05	1			
28	GRILLE	ABS	102936-03	1			
29	ADJUSTABLE LEG	222-P-16B	417192-01	4			
30	LOUVER (A)	PP	103344-05	1			
31	AIR FILTER (A)	PP	208840G01	1			
32	TAPPING SCREW (BLACK)	STEEL,4x8	433954-01	1			

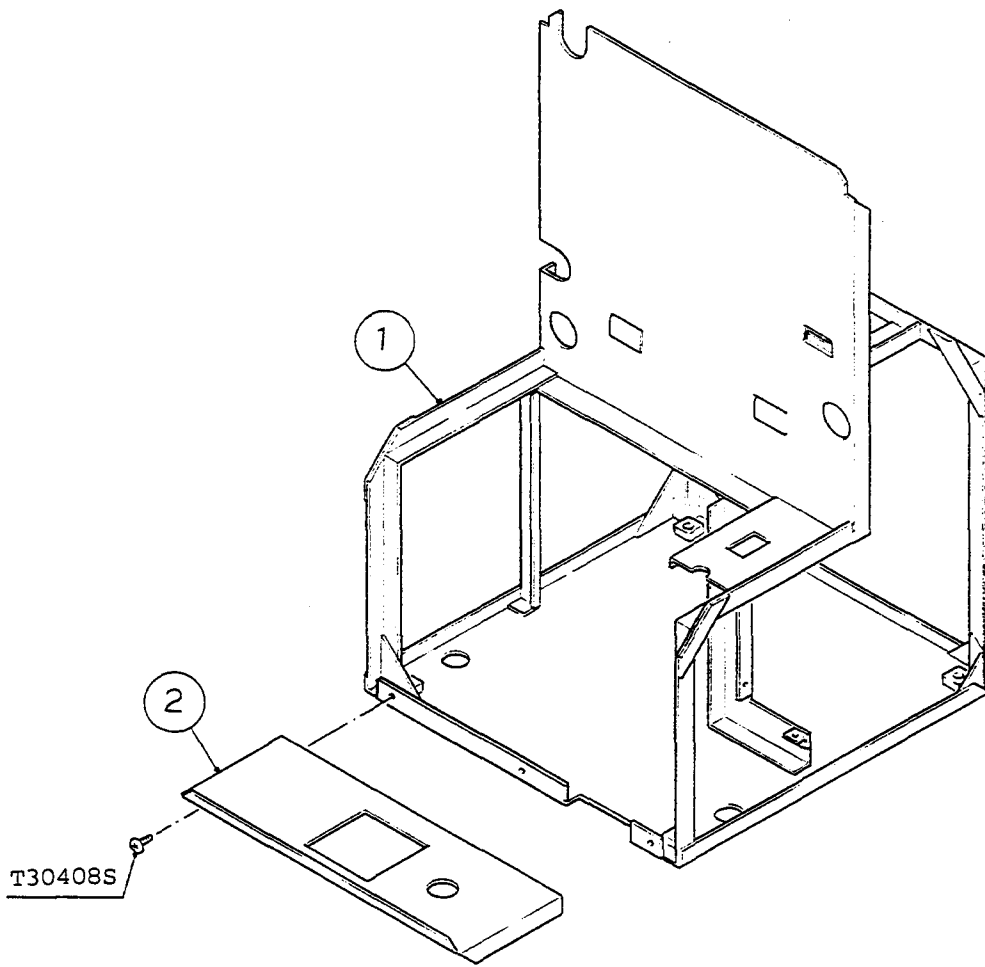

MODEL: DCM-240BAE								TITLE: B. FRAME ASSY			
INDEX NO.	DESCRIPTION	MATERIAL OR MODEL NUMBER	PART NUMBER	REQ'D NUMBER							
				D-1							
1	FRAME (A)	G.S	106824G02	1							
2	FRAME (B)	G.S	329483-01	1							

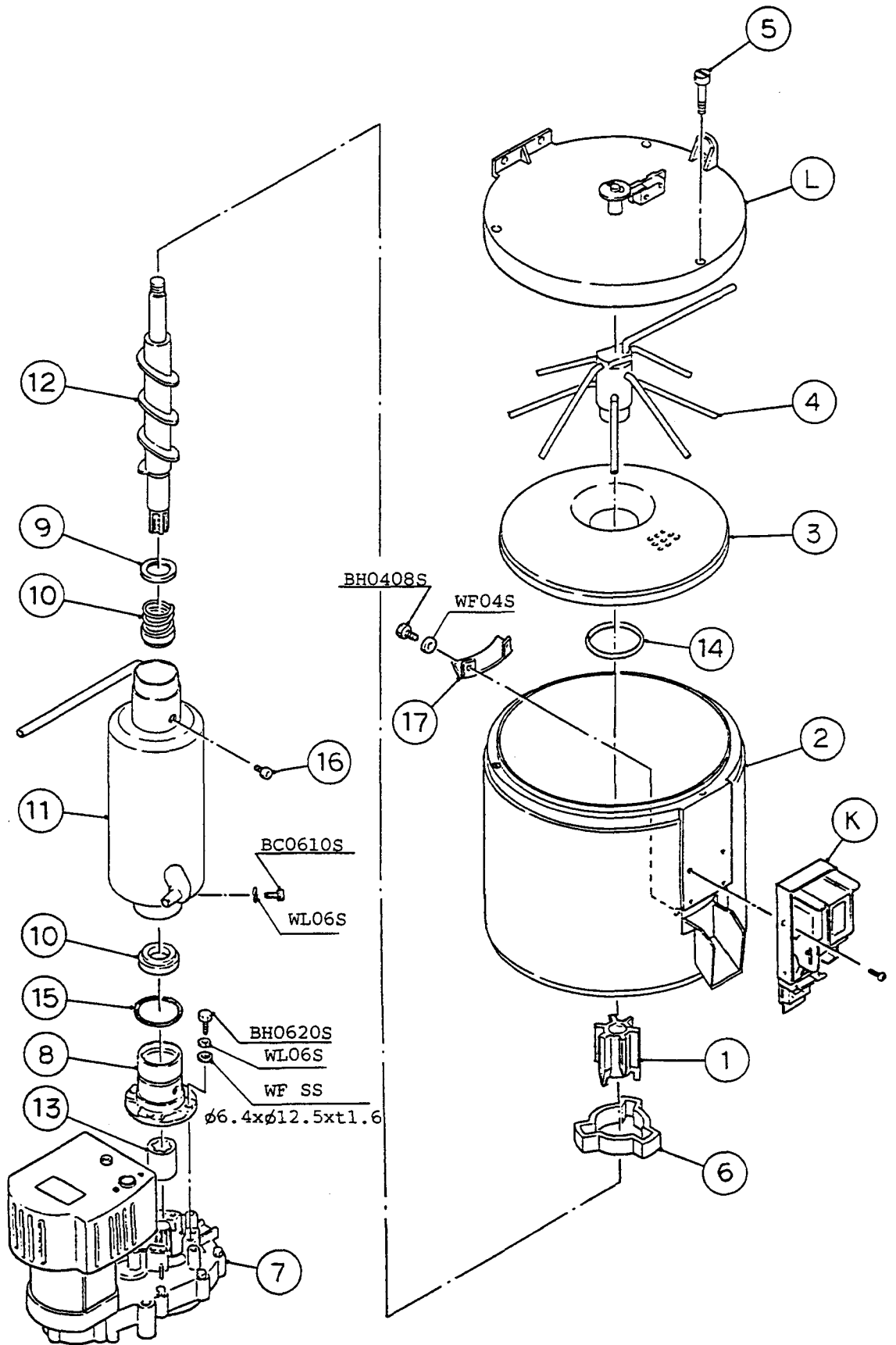

MODEL: DCM-240BAE TITLE: C. ICE MAKING UNIT							
INDEX NO.	DESCRIPTION	MATERIAL OR MODEL NUMBER	PART NUMBER	REQ'D NUMBER			
				D-1			
K	SHUTTER ASSY		211265A09	1			
L	COVER ASSY-BIN TOP		207757A01	1			
1	EXTRUDING HEAD-45C	S.S.	327236G02	1			
2	STORAGE BIN	--	211630G01	1			
3	DRIP RING	S.S.	207754-01	1			
4	AGITATOR	S.S.	314997G01	1			
5	THUMBSCREW	S.S, ABS	430825G01	3			
6	COVER - UPPER, EVAPORATOR	PE FOAM	413446-01	1			
7	GEAR MOTOR	TC1125, 120V 80W	2U0105-01	x1			
		TC1148, 120V SOW	2U0146-01	o1			
8	HOUSING	COPPER ALLOY	206013G03	1			
9	RING (B)	S.S	432494-01	1			
10	MECHANICAL SEAL	HK9A-MS	432491-01	1			
11	EVAPORATOR - INSULATION AD		332576G01	1			
12	AUGER	S.S	328527G01	1			
13	COUPLING - SPLINE	S.S	418316-01	1			
14	"0" RING	P48	7616-P048	1			
15	"0" RING	G40	7616-G040	1			
16	SOCKET HEAD CAP SCREW	S.S, M8x14	429121-01	3			
17	DRIP PLATE (B)	S.S	412676-01	1			



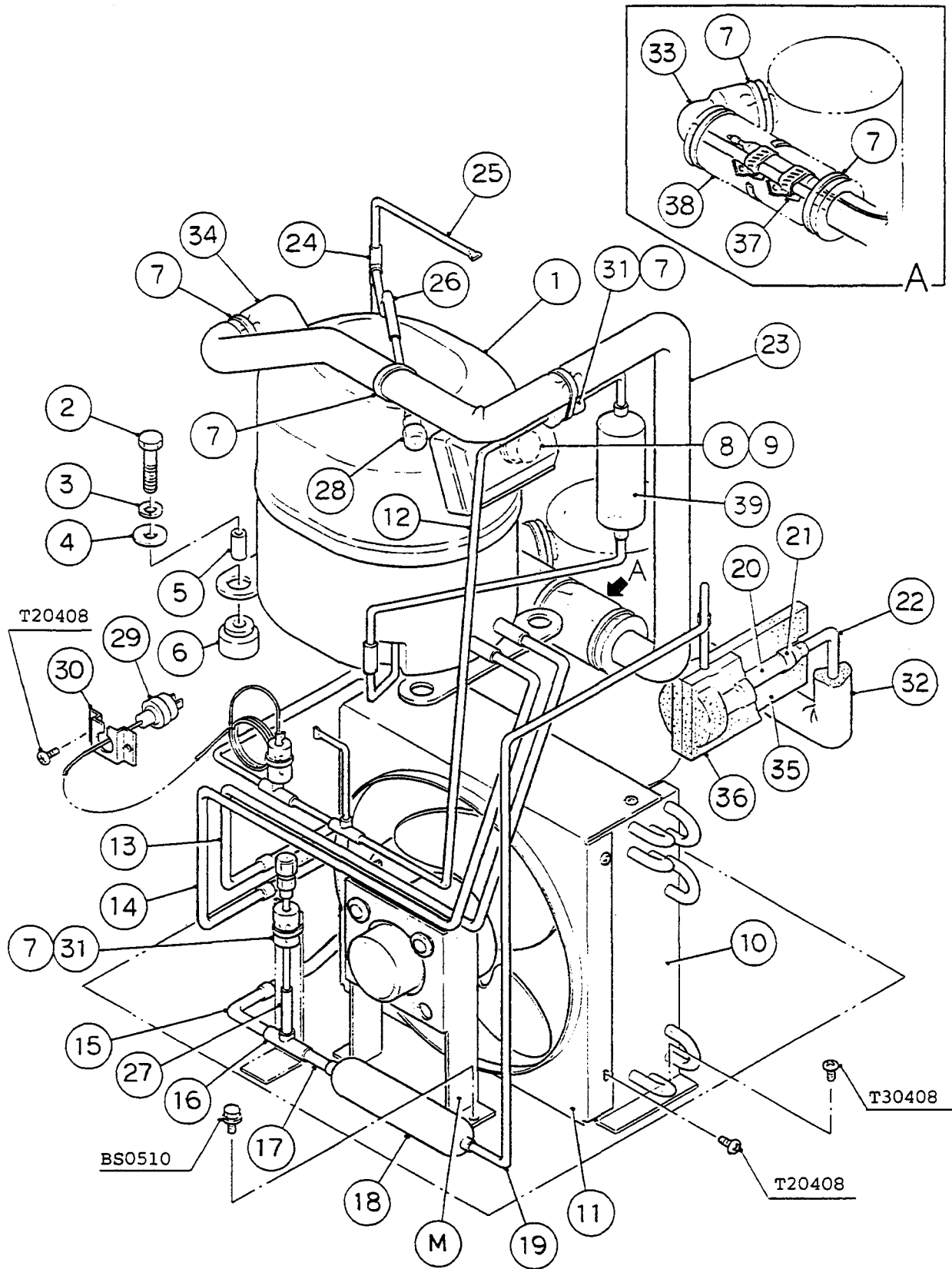

MODEL: DCM-240BAE		TITLE: D. REFRIGERATION CIRCUIT					
INDEX NO.	DESCRIPTION	MATERIAL OR MODEL NUMBER	PART NUMBER	REQ'D NUMBER			
				D-1			
M	FAN MOTOR ASSY	(S-0375)	313392A01	1			
1	COMPRESSOR	CF180J1N-1U Ø1.120V 400W	444746-01	1			
2	HEXAGON HEAD BOLT	--	444746F01	4			
3	SPRING WASHER	--	444746F02	4			
4	WASHER	--	444746F03	4			
5	SPACER	--	444746F04	4			
6	RUBBER CUSHION	--	444746F05	4			
7	TIE	CV-150	7920-0003	10			
8	HOLDER-OVERLOAD	--	434397-01	1			
9	OVERLOAD	OL-156EL	445674-01	1			
10	CONDENSER	--	220563-01	1			
11	SHROUD	G. S.	307663-01	1			
12	COPPER TUBE	COPPER	334125G02	1			
13	COPPER TUBE	COPPER	332580-02	1			
14	COPPER TUBE	COPPER	332581-02	1			
15	COPPER TUBE	COPPER	446630-02	1			
16	TEE	COPPER	420041-02	1			
17	COPPER TUBE	Ø 8.0xt0.8, L=40	106827-21	1			
18	DRIER	DY-2HD-2	444795-01	1			
19	COPPER TUBE	COPPER	332582-02	1			
20	EXPANSION VALVE	HFE-5HHD-3	445677-02	1			
21	REDUCER	COPPER	421904-01	1			
22	COPPER TUBE	COPPER	446631-02	1			
23	COPPER TUBE	COPPER	220564G02	1			
24	TEE	COPPER	417394-01	1			
25	COPPER TUBE	Ø 6.35xt0.8, L=150	106827-29	1			
26	COPPER TUBE	COPPER	446768-01	1			
27	COPPER TUBE	COPPER	446768-02	1			
28	ACCESS VALVE	TCJ-2F15-HD	417366-01	2			

MODEL: DCM-240BAE		TITLE: D. REFRIGERATION CIRCUIT					
INDEX NO.	DESCRIPTION	MATERIAL OR MODEL NUMBER	PART NUMBER	REQ'D NUMBER			
				D-1			
29	PRESSURE SWITCH	ACB-2UB03	433441-03	1			
30	BRACKET - PRESSURE SWITCH	G.S	425506-01	1			
31	INSULATION TUBE	7762-0717, L=30	106827-36	3			
32	INSULATION TUBE	7762-1030, L=270	106827-37	1			
33	INSULATION TUBE	7762-1030, L=115	106827-38	1			
34	INSULATION TUBE	7762-1030, L=80	106827-39	1			
35	COVER (A) - EXPANSION VALVE	PE FOAM	324313-01	1			
36	COVER (B) - EXPANSION VALVE	PE FOAM	324313-02	1			
37	CLAMP	D11-S	435254-04	2			
38	INSULATION TUBE	7762-2949, L=150	106827-43	2			
39	COPPER TUBE	COPPER	334128G02	1			

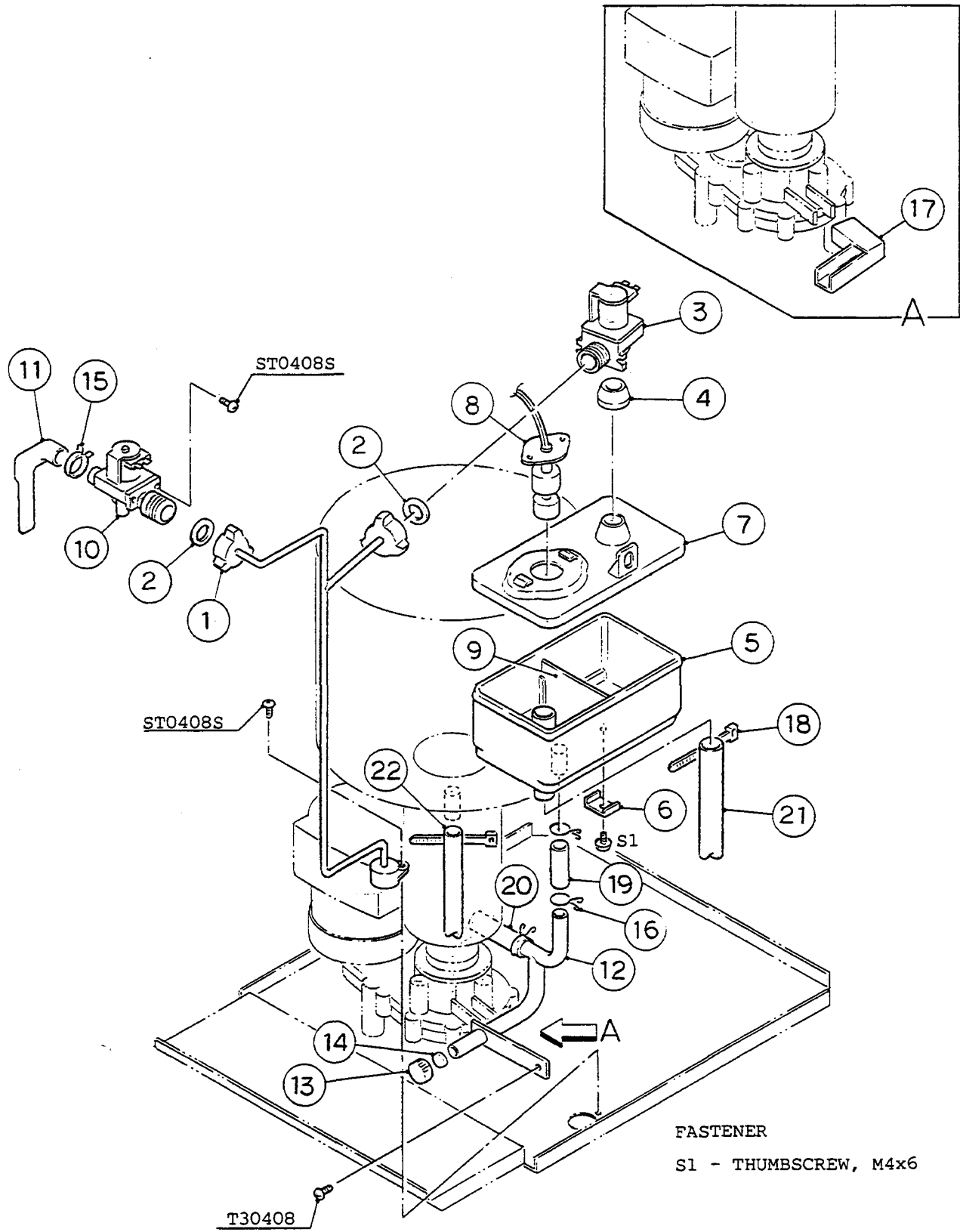

FASTENER  
S1 - THUMBSCREW, M4x6

MODEL: DCM-240BAE				TITLE: E. WATER CIRCUIT			
INDEX NO.	DESCRIPTION	MATERIAL OR MODEL NUMBER	PART NUMBER	REQ'D NUMBER			
				D-1			
1	PIPE - WATER SUPPLY	S. S	319700G01	1			
2	PACKING	NBR	413854-03	2			
3	WATER VALVE	J246-086	3U0065-01	1			
4	COVER - RESERVOIR INLET	SI.R	415094-01	1			
5	RESERVOIR	ABS	207527-01	1			
6	COLLAR	S. S	423416-01	1			
7	COVER - RESERVOIR	ABS	103070-01	1			
8	FLOAT SWITCH	TW-1221-101	435490-01	1			
9	SEPARATOR - RESERVOIR	ABS	423538-01	1			
10	WATER VALVE	J246-317	3U0066-01	1			
11	PIPE - WATER SUPPLY	SI.R	427618-02	1			
12	PIPE - JOINT	S. S	319701G01	1			
13	CAP - DRAIN	BRASS	425629-01	1			
14	PACKING - DRAIN	SY.R	418071-03	1			
15	CLAMP	HB20T19	423866-02	1			
16	CLAMP	SK-14	435934-02	4			
17	PIPE - DRAIN	EPDM	429620-01	1			
18	TIE	CV-150	7920-0003	2			
19	SILICONE HOSE	7730-1114,L=45	105416-21	1			
20	SILICONE HOSE	7730-1114,L=70	105416-22	1			
21	SILICONE HOSE	7730-1721, L=250	105416-23	1			
22	HOSE	7716-1216, L=350	105416-24	1			

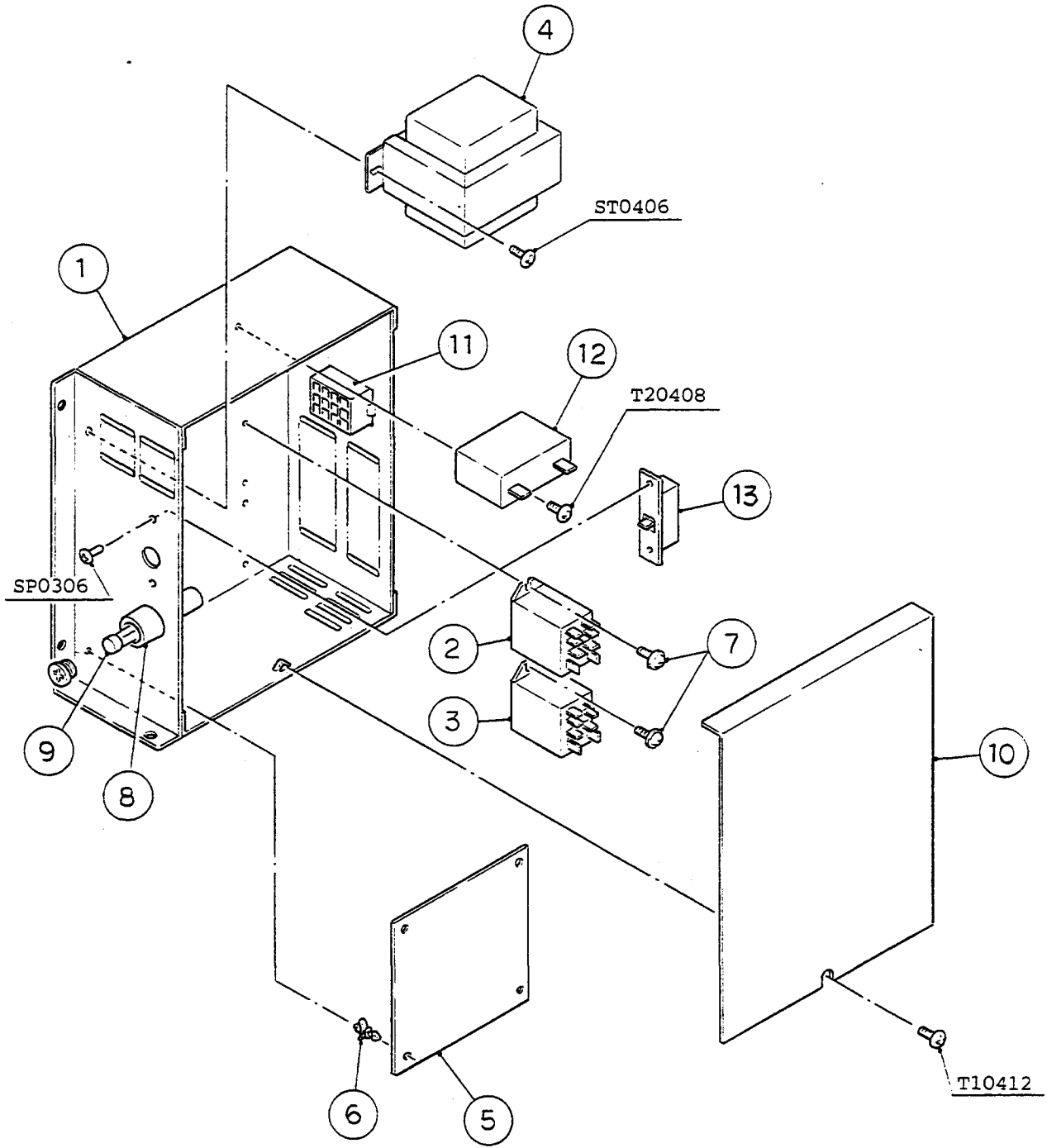

MODEL: DCM-240BAE		TITLE: F. CONTROL BOX (A) ASSY					
INDEX NO.	DESCRIPTION	MATERIAL OR MODEL NUMBER	PART NUMBER	REQ'D NUMBER			
				D-1			
1	CONTROL BOX (A)	G.S	332583G02	1			
2	RELAY	LY2ZF, AC24V	406132-06	1			
3	RELAY	LY1F.AC120V	418271 -03	1			
4	TRANSFORMER	TR5267, 120/240V1A	2U0042-01	1			
5	TIMER BOARD	H2AA144C02	437305-02	1			
6	BOARD SUPPORT	KGLS-6S	414929-01	4			
7	TAPPING SCREW	3x8	431415-01	4			
8	FUSE HOLDER	FH032, 250V10A	424288-01	1			
9	FUSE	FGA02.250V1A	420468-03	1			
10	COVER - CONTROL BOX (A)	G.S	446632-01	1			
11	12P PLUG HOUSING	3191-12P	412832-04	1			
12	CAPACITOR	280VAC,10uF	416921-05	1			
13	OVERLOAD - GEAR MOTOR	NW-3P-2	427253-01	1			

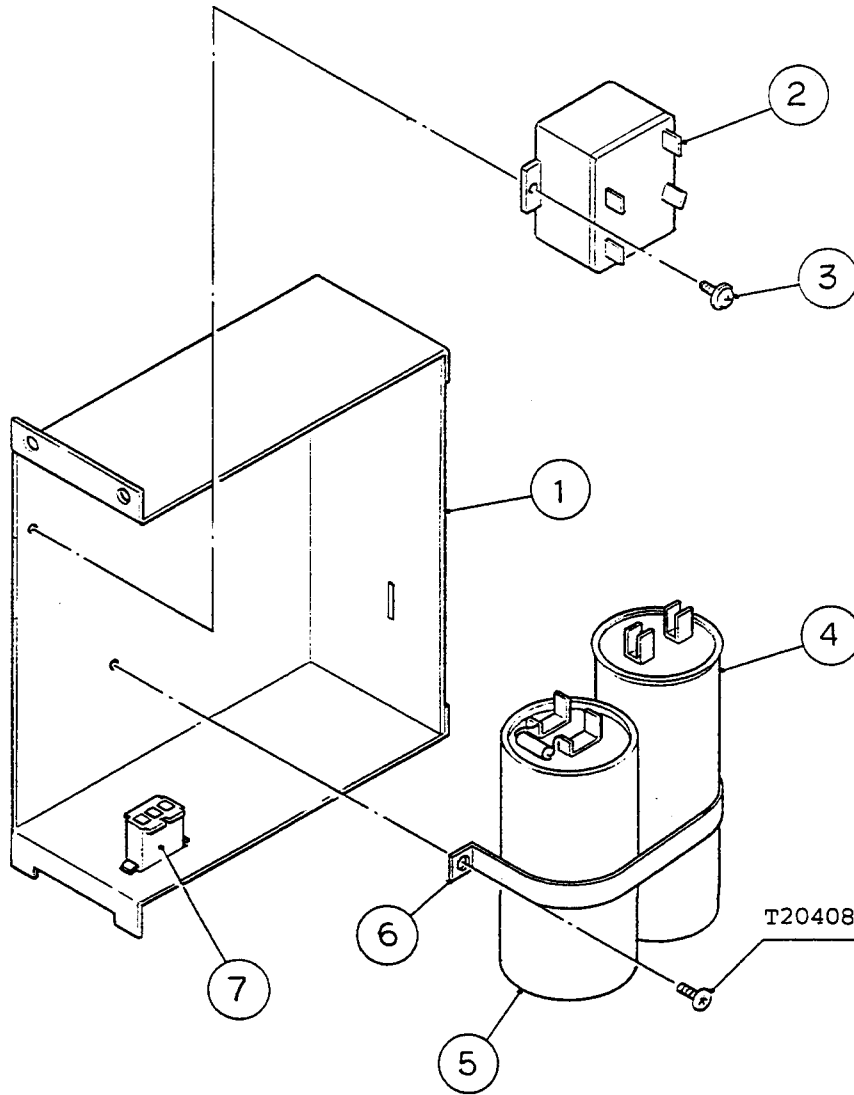



MODEL: DCM-240BAE TITLE: G. CONTROL BOX (B) ASSY							
INDEX NO.	DESCRIPTION	MATERIAL OR MODEL NUMBER	PART NUMBER	REQ'D NUMBER			
				D-1			
1	CONTROL BOX (B)	G. S	220566-02	1			
2	STARTER	AMVL-180BF	440251 -02	1			
3	TAPPING SCREW	3x8	431415-01	2			
4	RUN CAPACITOR	PMT-40300P	446661-01	1			
5	START CAPACITOR	MS240F100(J)-R	426901-01	1			
6	STRAP - CAPACITOR	G.S	446633-02	1			
7	3P PLUG HOUSING	3191-03P	412832-06	1			

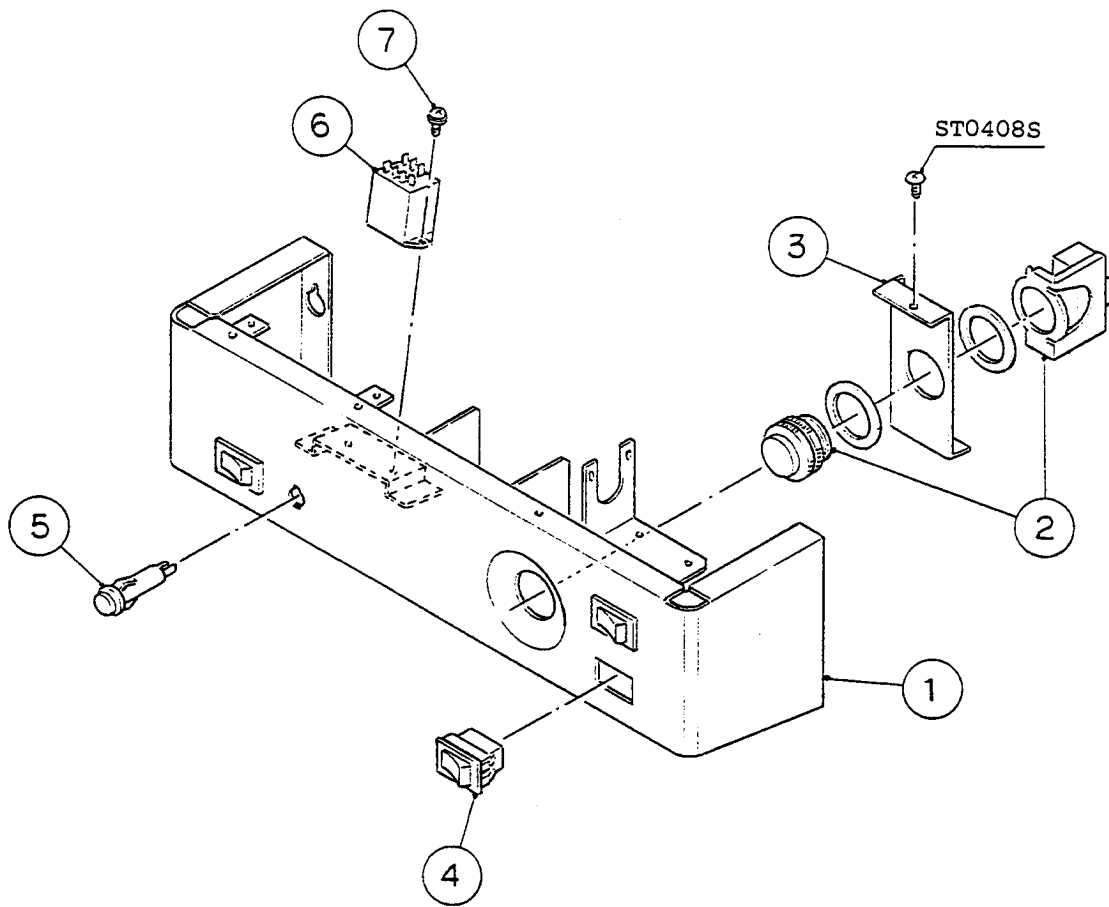

MODEL: DCM-240BAE		TITLE: H. MIDDLE FRONT PANEL ASSY					
INDEX NO.	DESCRIPTION	MATERIAL OR MODEL NUMBER	PART NUMBER	REQ'D NUMBER			
				D-1			
1	MIDDLE FRONT PANEL	S.S	220721 G01	1			
2	PUSH SW.	ZAP-1B(UL)	435745-02	1			
3	SW. BRACKET	S.S	440437-01	1			
4	ROCKER SWITCH	HLS112A	421490-01	4			
5	LAMP	621 T-2	446400-01	1			
6	RELAY	LY1F,AC120V	418271-03	1			
7	TAPPING SCREW	3x8	431415-01	2			

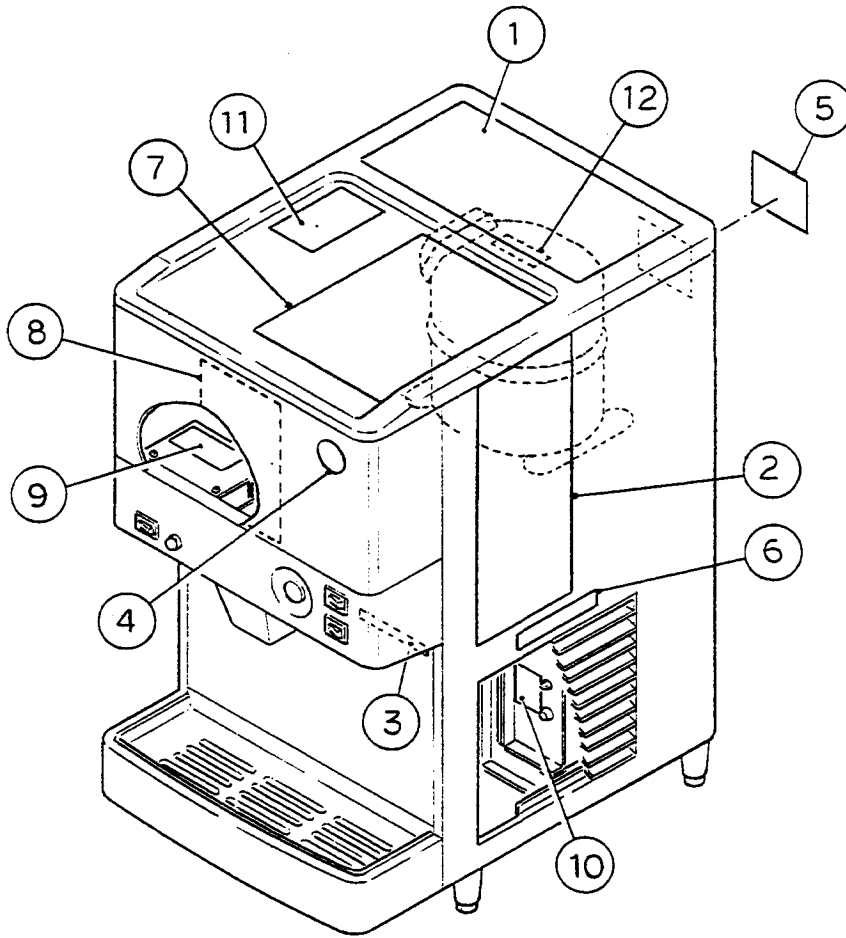

MODEL: DCM-240BAE		TITLE: J. LABEL LOCATION					
INDEX NO.	DESCRIPTION	MATERIAL OR MODEL NUMBER	PART NUMBER	REQ'D NUMBER			
				D-1			
1	INSTRUCTION SHEET	PAPER	216397-01	1			
2	INSTRUCTION LABEL	PES	216398-01	1			
3	MODEL NUMBER LABEL	PES	445782-21	1			
4	LABEL-PENGUIN	PETP FILM	434432-01	1			
5	NAMEPLATE	PES FILM	446650-01	1			
6	LABEL-AIR FILTER	PETP FILM	426177-01	1			
7	LABEL - CLEANING	PETP FILM	216399-01	1			
8	WIRING LABEL	PVC FILM	332593-01	1			
9	RATING LABEL	PES FILM	446651-01	1			
10	LABEL - RESET	PETP FILM	435319-01	1			
11	CAUTION LABEL (L)	PVC FILM	441560-01	1			
12	LABEL -R22	PES FILM	440362-01	01			

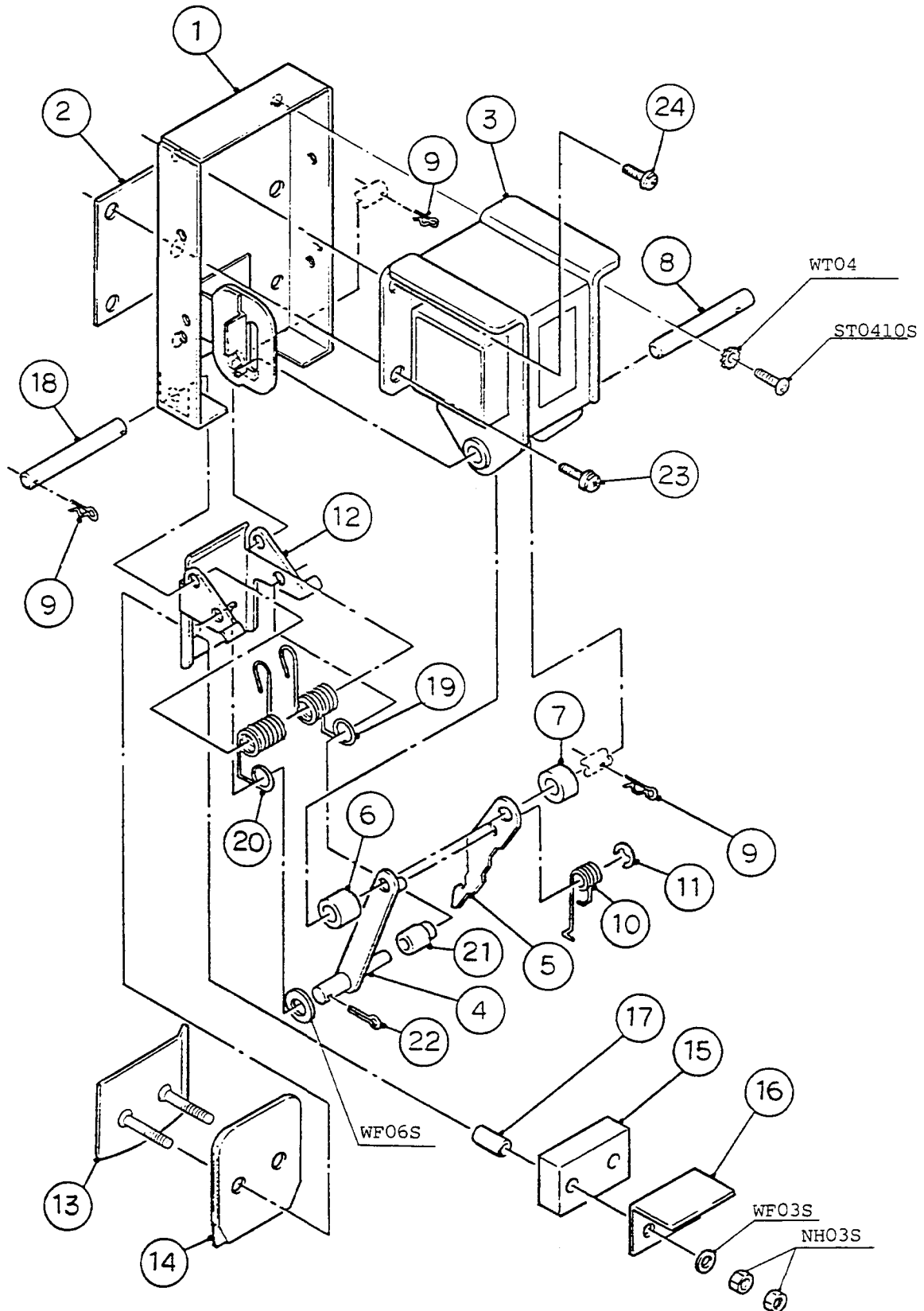

MODEL: DCM-240BAE		TITLE: K. SHUTTER ASSY					
INDEX NO.	DESCRIPTION	MATERIAL OR MODEL NUMBER	PART NUMBER	REQ'D NUMBER			
				D-1			
1	BRACKET-SOLENOID	S.S	320896G02	1			
2	SPACER	ABS	432514-01	1			
3	SOLENOID	AS-20-NO75	437926-01	1			
4	SHAFT	S.S	441645G01	1			
5	HOOK-SHUTTER	S.S	438406-01	1			
6	COLLAR (A)	ABS	432524-01	1			
7	COLLAR (B)	ABS	432524-02	1			
8	SHAFT (A) - SOLENOID	S.S	432517-02	1			
9	SNAP PIN	S.S, SSP-5	715S-0005	3			
10	SPRING	S.S	411532-01	1			
11	"E" RING	S.S, 4	721S-0004	1			
12	STOPPER	S.S	432518-03	1			
13	PLATE (A)-SHUTTER	S.S	423946G01	1			
14	PLATE (B) - SHUTTER	EPDM	423948-01	1			
15	PLATE(C) - SHUTTER	SY. R FOAM	419150-01	1			
16	PLATE(D) - SHUTTER	S.S	419151-01	1			
17	COLLAR (C) - SHUTTER	S.S	411539-03	2			
18	SHAFT (A)	S.S	432523-01	1			
19	SPRING (RIGHT)	S.S	434478-01	1			
20	SPRING (LEFT)	S.S	434479-01	1			
21	SHAFT (B2)	S.S	432520-02	1			
22	SPLIT PIN	S.S, 1.6x15	711SP1615	1			
23	SCREW	S.S, 4x12	434838-02	4			
24	SCREW	S.S, 4x8	434838-01	1			

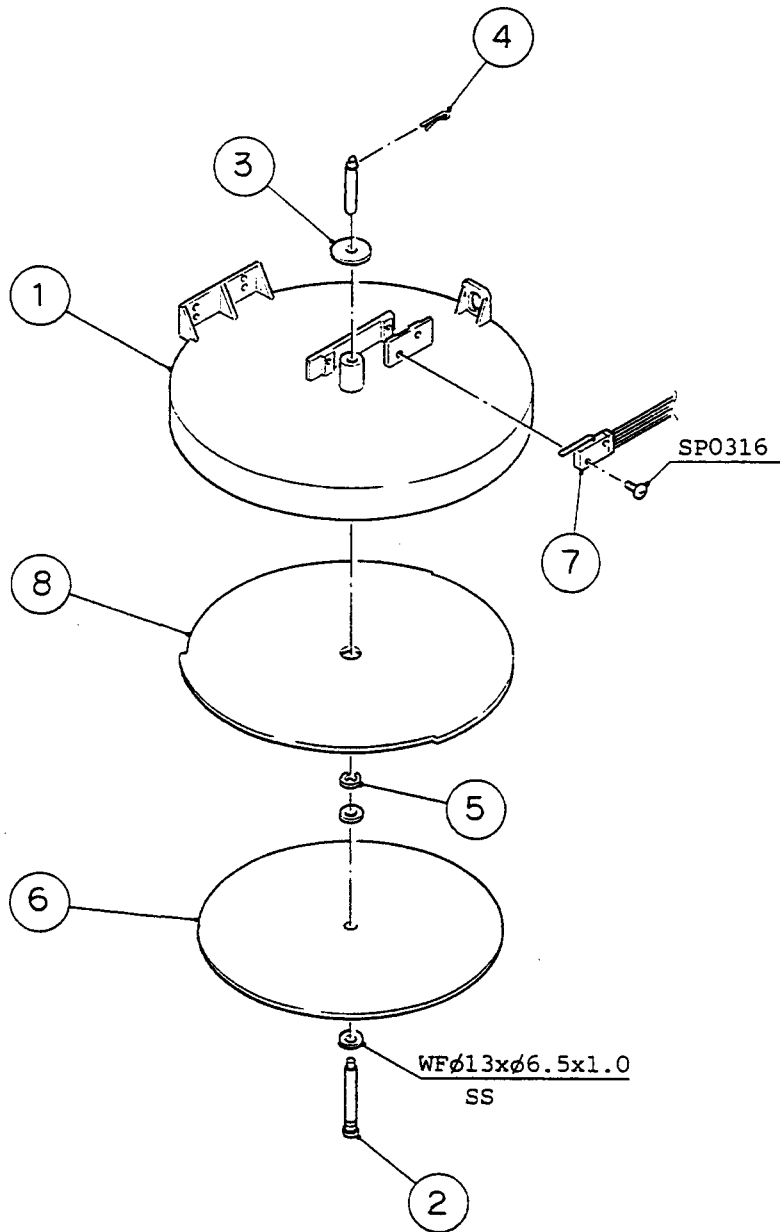



MODEL; DCM-240BAE		TITLE: L. COVER ASSY - BIN TOP					
INDEX NO.	DESCRIPTION	MATERIAL OR MODEL NUMBER	PART NUMBER	REQ'D NUMBER			
				D-1			
1	COVER - BIN TOP	ABS	103829G01	1			
2	SHAFT	S.S	423958-01	1			
3	BALANCE PLATE	S.S	423959-01	1			
4	SNAP PIN	S.S, SSP-4	715S-0004	1			
5	"E" RING	S.S, 5	721 S-0005	1			
6	BALANCE PLATE	ABS	417473-02	1			
7	MICROSWITCH	V-5L11155W	423950-01	1			
8	INSIDE PLATE	ABS	207830-01	1			

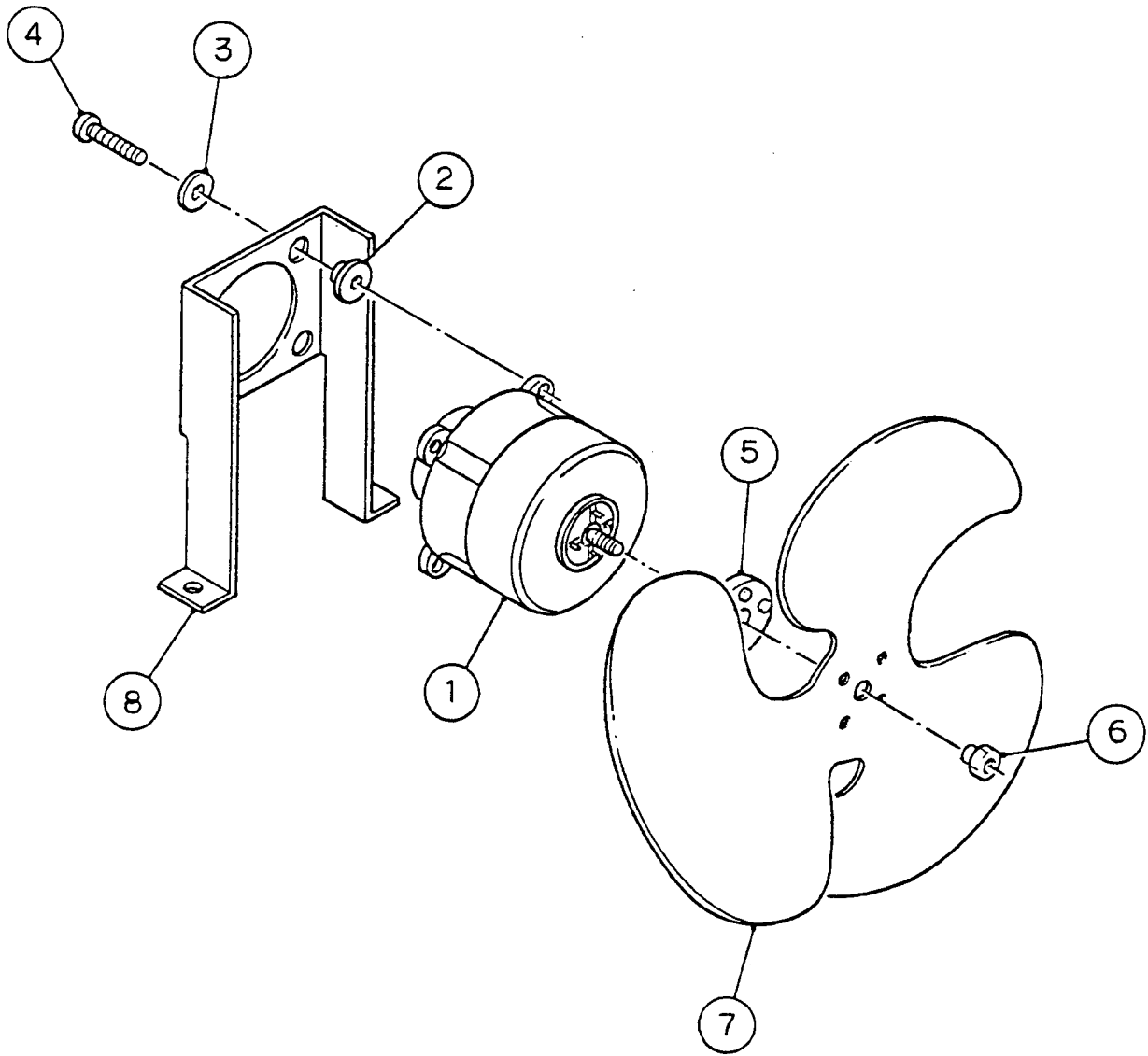

MODEL: DCM-240BAE		TITLE: M. FAN MOTOR ASSY					
INDEX NO.	DESCRIPTION	MATERIAL OR MODEL NUMBER	PART NUMBER	REQ'D NUMBER			
				D-1			
1	FAN MOTOR	EK-TZ2	2U0005-01	1			
2	GROMMET(A)	NR	414390F01	4			
3	WASHER-GROMMET	STEEL	414390F03	8			
4	SCREW	STEEL	414390F05	4			
5	VIBRATION PAD	SLR	414390F06	1			
6	NUT	STEEL	414390F07	1			
7	FAN BLADE	0230, ALUMINUM	414392-01	1			
8	BRACKET (B) - FAN MOTOR	G. S	307282-02	1			

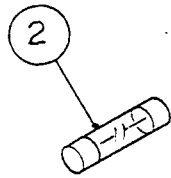
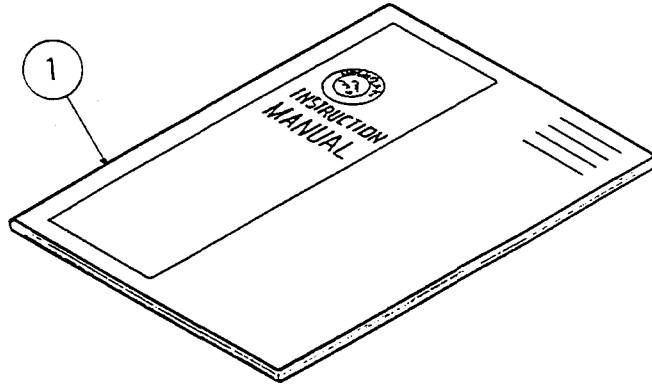

MODEL: DCM-240BAE		TITLE: N. ACCESSORIES					
INDEX NO.	DESCRIPTION	MATERIAL OR MODEL NUMBER	PART NUMBER	REQ'D NUMBER			
				D-1			
1	INSTRUCTION MANUAL	PAPER	91U2GW10A	1			
2	FUSE	FGAO2.250V1A	420468-03	1			