

---

NO. 71147

ISSUED: AUG. 6, 1999

---

REVISED: AUG. 26, 2002

---



**HOSHIZAKI  
CUBELET ICE DISPENSER**

**MODEL  
DCM-240BAF**

**(FINAL) PARTS LIST**

G-0 June 1997  
H-0 Dec., 1997  
J-0 Jan., 1999  
K-0 Dec., 1999  
L-0 Jan., 2001

## MATERIAL ABBREVIATIONS

### ALUMINUM

AL = Aluminum

### COPPER

CU = Copper

### PLASTIC

ABS = Acrylonitrile -butadiene - styrene  
 AC = Polyacetal  
 EVA = Ethylene vinyl acetate  
 PA = Polyamide = Nylon  
 PC = Polycarbonate  
 PE = Polyethylene  
 PES = Polyester  
 PETP = Polyethylene terephthalate = Tetlon  
 PP = Polypropylene  
 PS = Polystyrene  
 PIFE = Polytetrafluoroethylene = Teflon  
 PUR = Polyurethane  
 PVC = Polyvinyl chloride

### RUBBER

VN = Vinyl Nitrile  
 EPDM = EP rubber  
 NBR = Nitrile butadiene rubber  
 NR = Natural rubber  
 NP = Neoprene  
 SI.R = Silicone rubber  
 SY.R = Synthetic rubber  
 EPH = Epichlorohydrin

### STEEL

GS = Galvanized steel  
 SS = Stainless steel  
 PS = Plated steel  
 PAS = Primed steel

## AUXILIARY CODE

Ex.1

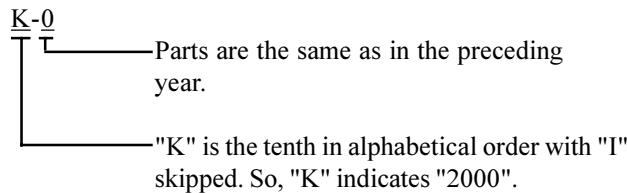

(Note) - = Part deleted.

x = Part deleted and replaced by "o" part.

Ex.2

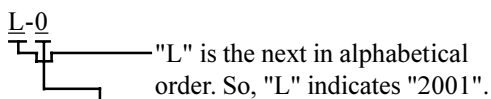

o = New part for "x" in the same auxiliary code.

Ex.3

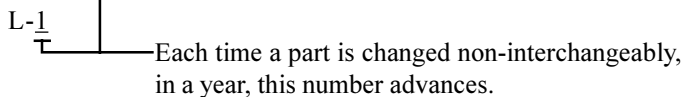

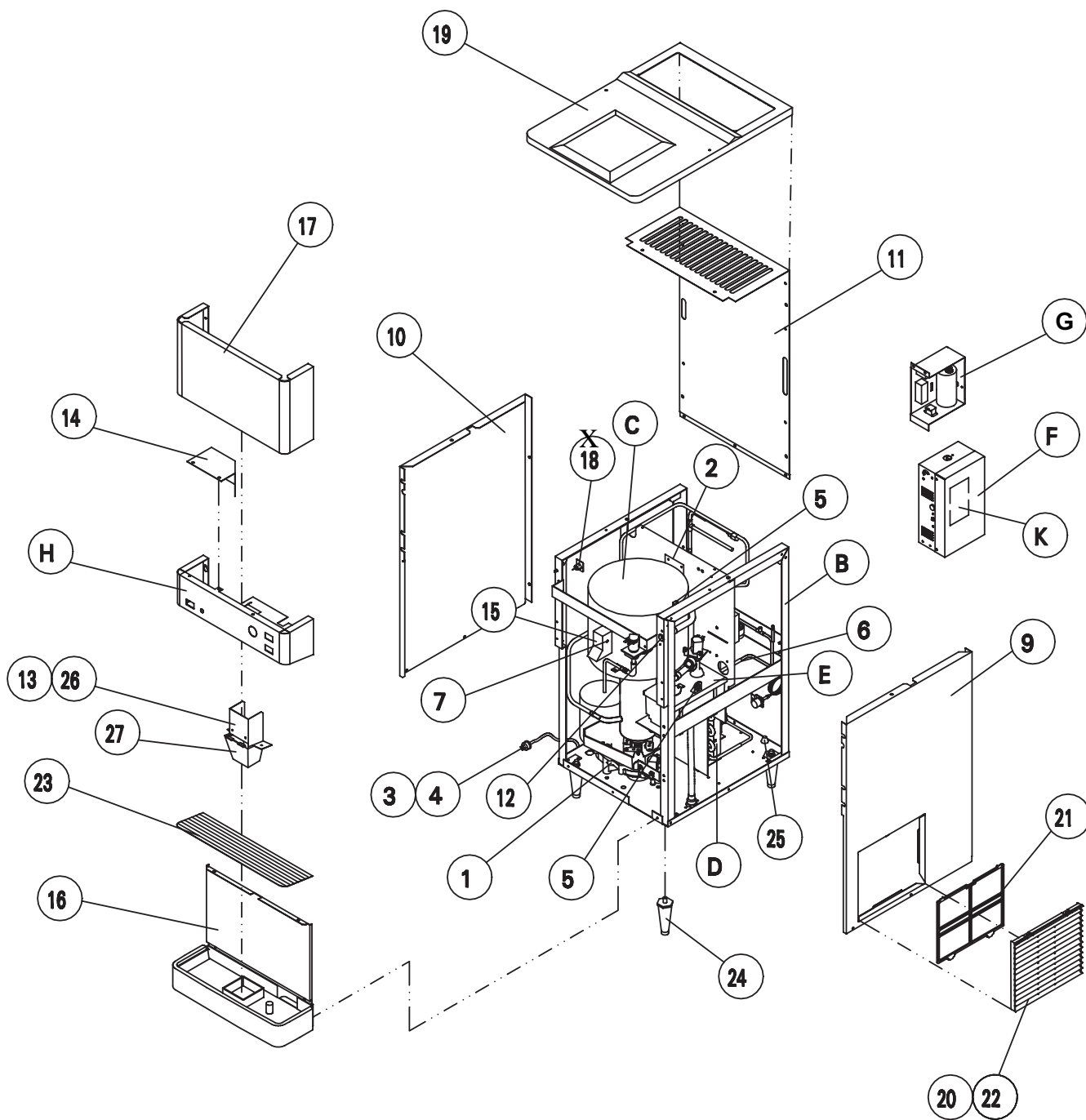

MODEL: DCM-240BAF TITLE: A. ICE DISPENSER ASSEMBLY											
INDEX NO.	DESCRIPTION	MATERIAL OR MODEL NUMBER	PART NUMBER	REQUIRED NUMBER							
				G-0	H-0	J-0	K-0	L-0			
B	FRAME ASSEMBLY	-	1A0174A01	1	1	1	1	1			
C	ICE MAKING UNIT ASSEMBLY	-	220559A03	1	1	1	1	1			
	SOCKET HEAD HEX BOLT	SS, 8 x 90	7S12-0890	3	3	3	3	3			
	SPRING WASHER	SS, 8		3	3	3	3	3			
D	REFRIGERATION CIRCUIT	-	2A0783A01	1	1	1	1	1			
E	WATER CIRCUIT ASSEMBLY	-	2A0778A01	1	1	1	1	1			
F	CONTROL BOX (A) ASSEMBLY	-	2A0788A01	1	1	1	1	1			
	TRUSS HEAD SCREW	4 x 8	7C31-0408	4	4	4	4	4			
G	CONTROL BOX (B) ASSEMBLY	-	2A0790A01	1	1	1	1	1			
	TRUSS HEAD SCREW	4 x 8	7C31-0408	4	4	4	4	4			
H	MIDDLE FRONT PANEL ASSEMBLY	-	3A0765A01	1	x1						
		-	3A0765A02		o1	1	1	1			
J	-	-	-								
K	LABEL LOCATION	-	3A0738A01	1	1	1	1	1			
1	DRAIN PAN - G.M.	-	3A0766G01	1	1	1	1	1			
2	THUMBSCREW	-	415949G04	2	2	2	2	2			
3	POWER SUPPLY CORD	-	440894-01	1	x1						
		-	4A1773-01		o1	1	1	1			
4	BUSHING		420472-02	1	1	1	1	1			
5	BUSHING		420472-03	2	2	2	2	2			
6	BUSHING		420472-06	2	2	2	2	2			
7	BUSHING		420472-01	1	1	1	1	1			
8	-	-	-								
9	RIGHT PANEL		2A0763-01	1	1	1	1	1			
	TRUSS HEAD SCREW	4 x 8	7C31-0408	3	3	3	3	3			
10	LEFT PANEL		2A0762-01	1	1	1	1	1			
	TRUSS HEAD SCREW	4 x 8	7C31-0408	3	3	3	3	3			

MODEL: DCM-240BAF TITLE: A. ICE DISPENSER ASSEMBLY										
INDEX NO.	DESCRIPTION	MATERIAL OR MODEL NUMBER	PART NUMBER	REQUIRED NUMBER						
				G-0	H-0	J-0	K-0	L-0		
11	TOP SUPPORT		2A0767-01	1	1	1	1	1		
	TRUSS HEAD SCREW	4 x 8	7C31-0408	4	4	4	4	4		
12	COLLAR		4H0171-01	5	5	5	6	6		
	FLAT HEAD SCREW	SS, 4 x 12	7C22-0412	5	5	5	6	6		
	FLAT WASHER	SS, 4	7W22-0400	5	5	5	6	6		
	TRUSS HEAD SCREW	4 x 8	7C31-0408	1	1	1	1	1		
13	THUMBSCREW	-	415949G08	1	1	1	1	1		
14	FRONT BARRIER (L)		425094-01	1	1	1	1	1		
	TRUSS HEAD SCREW	SS, 4 x 6	7C32-0406	2	2	2	2	2		
15	BARRIER SOLENOID		446692-01	1	1	1	1	1		
	PAN HEAD SCREW W/WASHER	SS, 4 x 8	7C1230408	4	4	4	4	4		
16	APRON PANEL		3A0737-01	1	1	1	1	1		
	TRUSS HEAD SCREW	SS, 4 x 6	7C31-0416	4	4	4	4	4		
17	FRONT PANEL		2A0766G01	1	1	1	1	1		
18	THUMBSCREW	-	4A0739-01	1	1	1	1	1		
19	TOP PANEL		1A0176-01	1	1	1	1	1		
	TRUSS HEAD SCREW W/PLASTIC WASHER		7C3230408	2	2	2	2	2		
20	LOUVER (A)		103344-07	1	1	1	1	1		
21	AIR FILTER (A)		208840G03	1	1	1	1	1		
22	TAPPING SCREW - BLACK	STEEL	433954-01	1	1	1	1	1		
23	GRILLE		102936-02	1	1	1	1	1		
24	ADJUSTABLE LEG	222-P-16B	417192-01	4	4	4	x4			
		-	4A2145-01				o4	4		
25	CLAMP		4A0337-10	2	2	2	2	2		
26	SPOUT (A)		105409-01	1	1	1	1	1		
27	SPOUT (B)		105410-01	1	1	1	1	1		

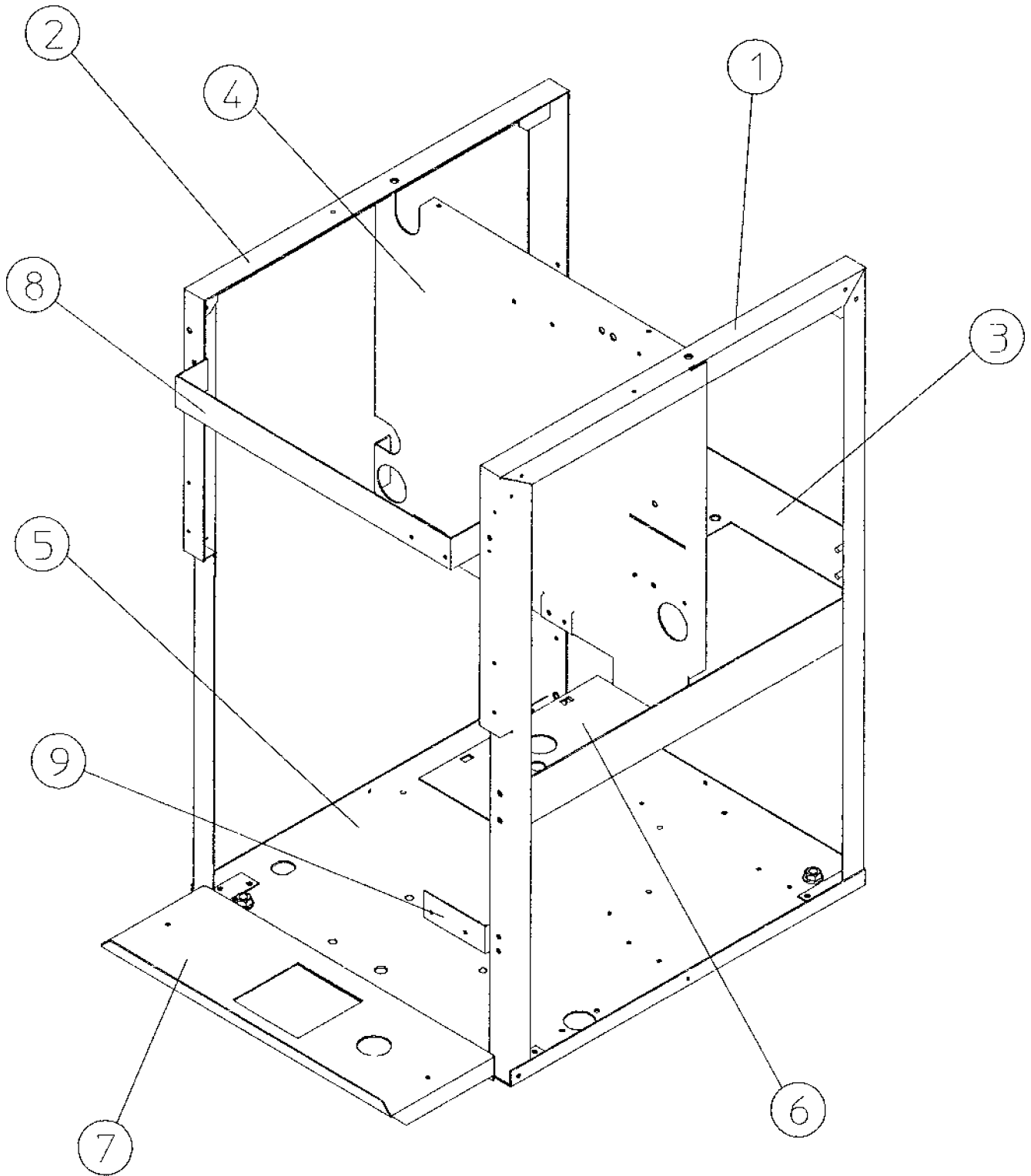

MODEL: DCM-240BAF TITLE: B. FRAME ASSEMBLY										
INDEX NO.	DESCRIPTION	MATERIAL OR MODEL NUMBER	PART NUMBER	REQUIRED NUMBER						
				G-0	H-0	J-0	K-0	L-0		
1	RIGHT SUPPORT ASSEMBLY		2A0760G01	1	1	1	1	1		
	FT SCREW	SS, 4 x 8	7F32-0408	4	4	4	4	4		
2	LEFT SUPPORT ASSEMBLY		2A0759G01	1	1	1	1	1		
	FT SCREW	SS, 4 x 8	7F32-0408	4	4	4	4	4		
3	COMPRESSOR SUPPORT		2A0755G01	1	1	1	1	1		
	TRUSS HEAD SCREW	4 x 8	7C31-0408	4	4	4	4	4		
	LOCK WASHER	SS, 5	7L22-0500	4	4	4	4	4		
	NUT	SS, 5		4	4	4	4	4		
4	PANEL		2A0761G01	1	1	1	1	1		
	TRUSS HEAD SCREW	4 x 8	7C31-0408	2	2	2	2	2		
	HEX BOLT	SS, 6 x 10		2	2	2	2	2		
	LOCK WASHER	SS, 6	7L22-0600	2	2	2	2	2		
5	BASE WELD NUT		3A0708G01	1	1	1	1	1		
6	RESERVOIR BRACKET		3A0707-01	1	1	1	1	1		
	TRUSS HEAD SCREW	4 x 8	7C31-0408	4	4	4	4	4		
7	DRAIN SUPPORT		3A0710-01	1	1	1	1	1		
	FT SCREW	SS, 4 x 8	7F32-0408	3	3	3	3	3		
8	SIDE SUPPORT BRCKT		3A0706-01	1	1	1	1	1		
	FT SCREW	SS, 4 x 8	7F32-0408	2	2	2	2	2		
9	FLUSH VALVE HOLDER		4A1105-01	1	1	1	1	1		
	FT SCREW	SS, 4 x 8	7F32-0408	2	2	2	2	2		

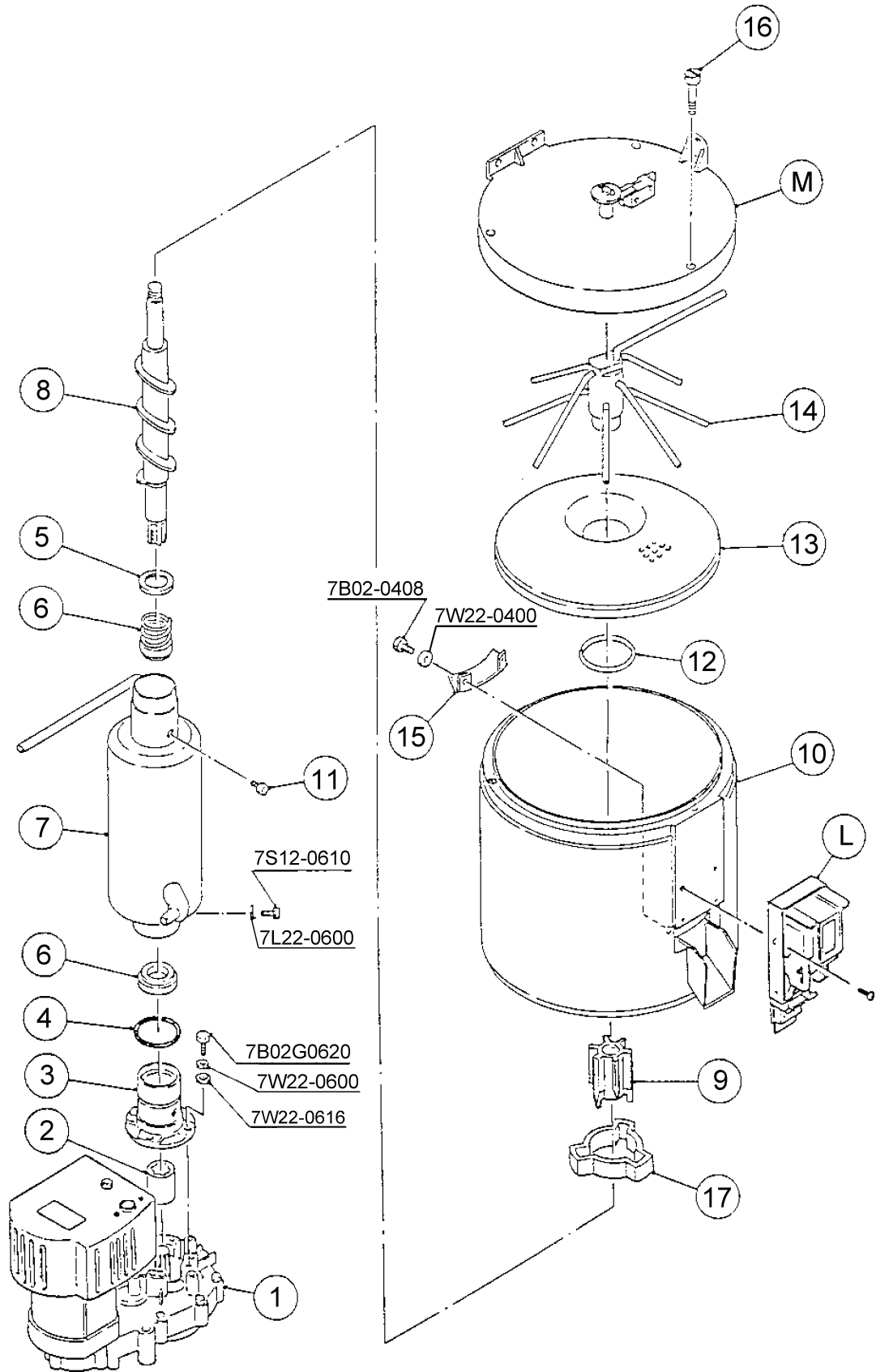



HA

MODEL: DCM-240BAF TITLE: C. ICE MAKING UNIT ASSEMBLY											
INDEX NO.	DESCRIPTION	MATERIAL OR MODEL NUMBER	PART NUMBER	REQUIRED NUMBER							
				G-0	H-0	J-0	K-0	L-0			
L	SHUTTER ASSEMBLY		211265A09	1	1	1	1	1			
M	COVER ASSEMBLY - BIN TOP		207757A01	1	1	1	1	1			
1	GEAR MOTOR	TC1185 1 Ø 120V 80W	2U0147-01	1	1	1	1	1			
2	COUPLING - SPLINE		418316-01	1	1	1	1	1			
3	HOUSING		206013G03	1	1	1	1	1			
	HEX BOLT (GOLD STAINLESS)	6 x 20	7B02G0620	4	4	4	4	4			
	PLAIN WASHER	SS, 6	7W22-0600	4	4	4	4	4			
	SPRING WASHER	SS, 6.4 X 12.5 X 1.6	7W22-0616	4	4	4	4	4			
4	"O" RING	G40	7616-G040	1	1	1	1	1			
5	RING (B)		432494-01	1	1	1	1	1			
6	MECHANICAL SEAL	HK9A-MS Ø 22	432491-01	1	1	1	1	1			
7	EVAPORATOR		332576G01	1	1	1	1	1			
	SOCKET HEAD CAP SCREW	SS, 6 X 10	7S12-0610	4	4	4	4	4			
	SPLIT LOCK WASHER	SS, 6	7L22-0600	4	4	4	4	4			
8	AUGER		328527G01	1	1	1	1	1			
9	EXTRUDING-OAD - 45C		327236G02	1	1	1	1	1			
10	STORAGE BIN		211630G01	1	1	1	1	1			
11	SOCKET HEAD CAP SCREW	SS, 8 X 14	429121-01	3	3	3	3	3			
12	"O" RING	P48	7616-P048	1	1	1	1	1			
13	DRIP RING		207754-01	1	1	1	1	1			
14	AGITATOR		314997G01	1	1	1	1	1			
15	DRIP PLATE (B)		412676-01	1	1	1	1	1			
	HEX. BOLT	SS, 4 X 8	7B02-0408	2	2	2	2	2			
	WASHER	SS, M4	7W22-0400	2	2	2	2	2			
16	THUMBSCREW		430825G01	3	3	3	3	3			

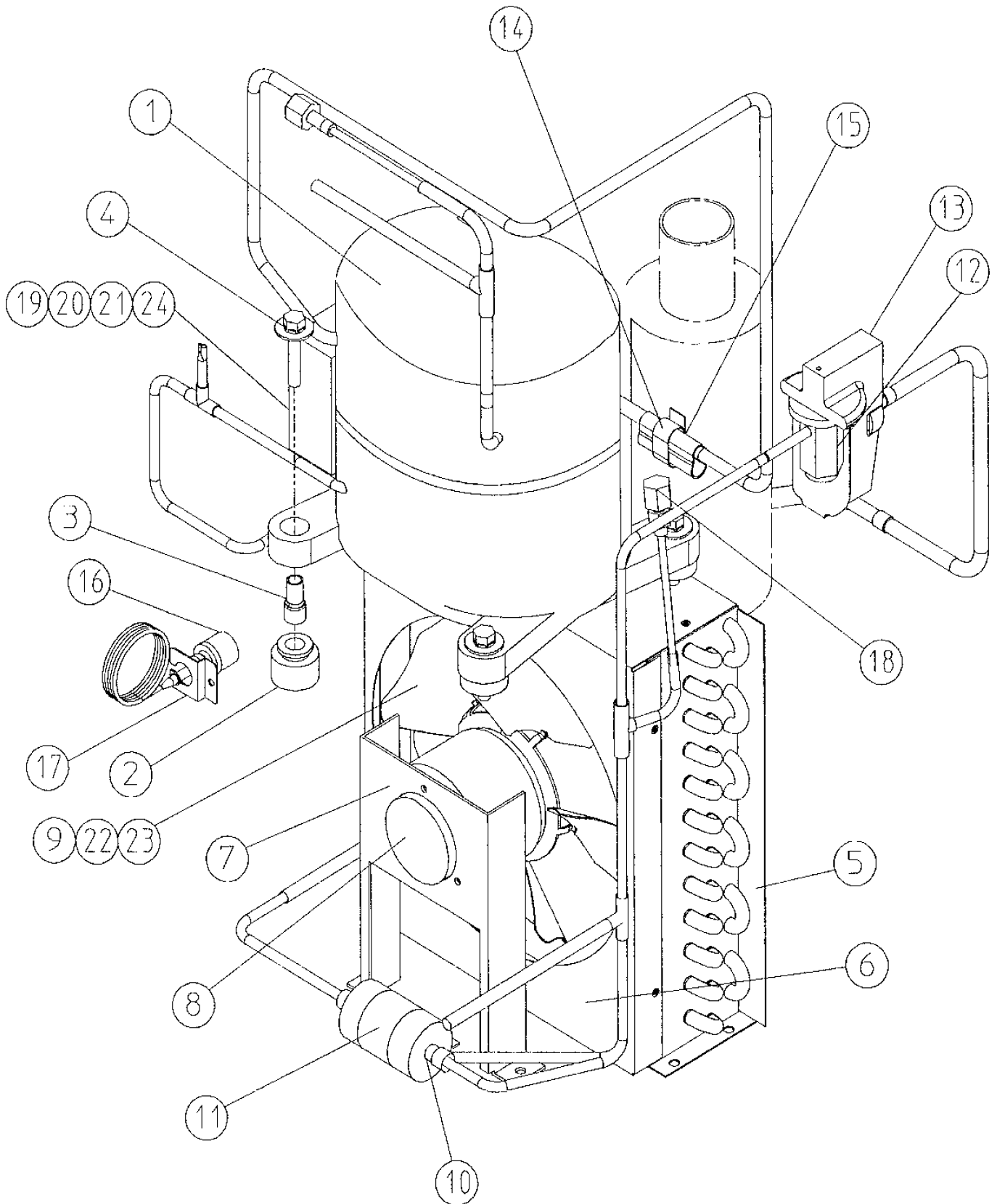

HA

MODEL: DCM-240BAF TITLE: D. REFRIGERATION CIRCUIT										
INDEX NO.	DESCRIPTION	MATERIAL OR MODEL NUMBER	PART NUMBER	REQUIRED NUMBER						
				G-0	H-0	J-0	K-0	L-0		
1	COMPRESSOR	J525-CIE	4A1177-01	1	1	1	1	1		
2	GROMMET		434403-01	4	4	4	4	4		
3	SPACER		434404-01	4	4	4	4	4		
4	BOLT		437889-01	4	4	4	4	4		
5	CONDENSER		2A0780-01	1	1	1	1	1		
	FT SCREW	SS, 4 x 8	7F32-0408	2	2	2	2	2		
6	FAN SHROUD		3A0715-01	1	1	1	1	1		
	T2 SCREW	4 X 8	7P31-0408	6	6	6	6	6		
7	FAN MOTOR BRACKET		3A0716-01	1	1	1	1	1		
	HEX HEAD BOLT WWASHER	SS, 5 X 10	7B1230510	2	2	2	2	2		
8	FAN MOTOR	SP-B16EMI	4A0815-01	1	1	1	1	1		
9	FAN BLADE	AD9CW38UBA	3A0608-01	1	1	1	1	1		
10	DRIER	THC-035	4A1113-01	1	1	1	1	1		
11	DRIER BRACKET		445847-01	1	1	1	1	1		
	T2 SCREW	SS, 4 X 8		1	1	1	1	1		
12	EXPANSION VALVE	AN-ISC	4A1117-01	1	1	1	1	1		
13	EXPANSION VALVE COVER		4A1168-01	1	1	1	1	1		
14	CLAMP		443461-02	1	1	1	1	1		
15	HOLDER EXPANSION VALVE-3/8		3A0107-01	1	1	1	1	1		
16	PRESSURE SWITCH	-	433441-05	1	1	1	1	1		
17	PRESSURE SWITCH BRACKET		434938-01	1	1	1	1	1		
	T2 SCREW	4 X 8	7P31-0408	1	1	1	1	1		
18	ACCESS VALVE	-	457729-01	1	1	1	1	1		
19	STARTER		4A1191-01	1	1	1	1	1		
20	PROTECTOR HOLDER		4A1248-01	1	1	1	1	1		
21	PROTECTOR		4A1246-01	1	1	1	1	1		
22	HEX NUT		4A1345-01	1	1	1	1	1		
23	WASHER		4A5983-01	1	1	1	1	1		
24	PAN HEAD SCREW	#6 – 32 x 1/4	4A0898-03	3	3	3	3	3		

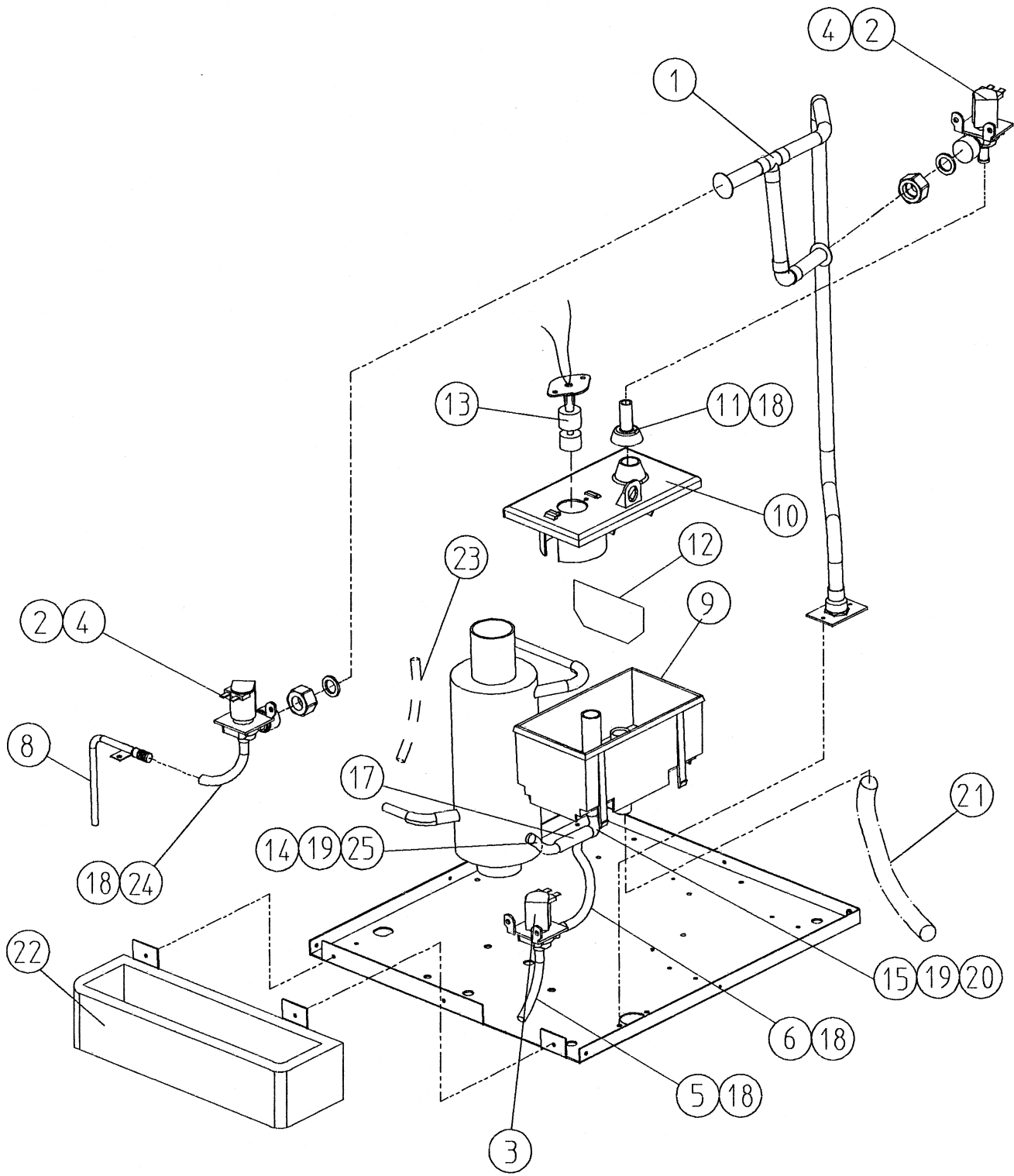

HA

MODEL: DCM-240BAF TITLE: E. WATER CIRCUIT ASSEMBLY											
INDEX NO.	DESCRIPTION	MATERIAL OR MODEL NUMBER	PART NUMBER	REQUIRED NUMBER							
				G-0	H-0	J-0	K-0	L-0			
1	WATER PIPE		2A0787G01	1	1	1	1	1			
2	WATER VALVE	S-30	4A0865-01	2	2	2	2	2			
	TRUSS HEAD SCREW	SS, 4 X 8	7C32-0408	2	2	2	2	2			
3	WATER VALVE	-	4A2077-01	1	1	1	1	1			
	TRUSS HEAD SCREW	SS, 4 X 8	7C32-0408	2	2	2	2	2			
4	WASHER	K-59963	4A0867-01	2	2	2	2	2			
5	VINYL HOSE	L=65	7716-0913	1	1	1	1	1			
6	SILICONE HOSE	L=300	7725-0912	1	1	1	1	1			
7	-	-	-								
8	WATER TUBE ASSEMBLY		4A1359G01	1	1	1	1	1			
	T2 SCREW	4 X 8		3	3	3	3	3			
9	RESERVOIR		2A0753-01	1	1	1	1	1			
10	RESERVOIR COVER		214810-01	1	1	1	1	1			
11	RESERVOIR INLET		4A0869-01	1	1	1	1	1			
12	SEPARATOR - RESERVOIR		4A1255-01	1	1	1	1	1			
13	FLOAT SWITCH	TW-1221-101	435490-01	1	1	1	1	1			
14	SILICONE HOSE	L=35	7730-1114	1	1	1	1	1			
15	RESERVOIR HOSE		4A1165-03	1	1	1	1	1			
16	-	-	-								
17	TEE	N8TUB6	4A1140-01	1	1	1	1	1			
18	CLAMP	2314 HC 468	4A2017-04	4	4	4	4	4			
19	CLAMP	2326 HC 672	4A2017-05	2	2	2	2	2			
20	CLAMP	2330 HC 750	4A2017-06	1	1	1	1	1			
21	VINYL HOSE	L=280	7725-1923	1	1	1	1	1			
22	DRAIN PAN		318857G02	1	1	1	1	1			
	TRUSS HEAD SCREW	SS, 4 X 16	7C32-0416	2	2	2	2	2			
23	HOSE – MAIN ASSEMBLY DRAIN		7725-0912	1	1	1	1	1			
24	VINYL HOSE	L=170	7725-0912	1	1	1	1	1			
25	CLAMP	2322 HC 593	4A2017-07	1	1	1	1	1			

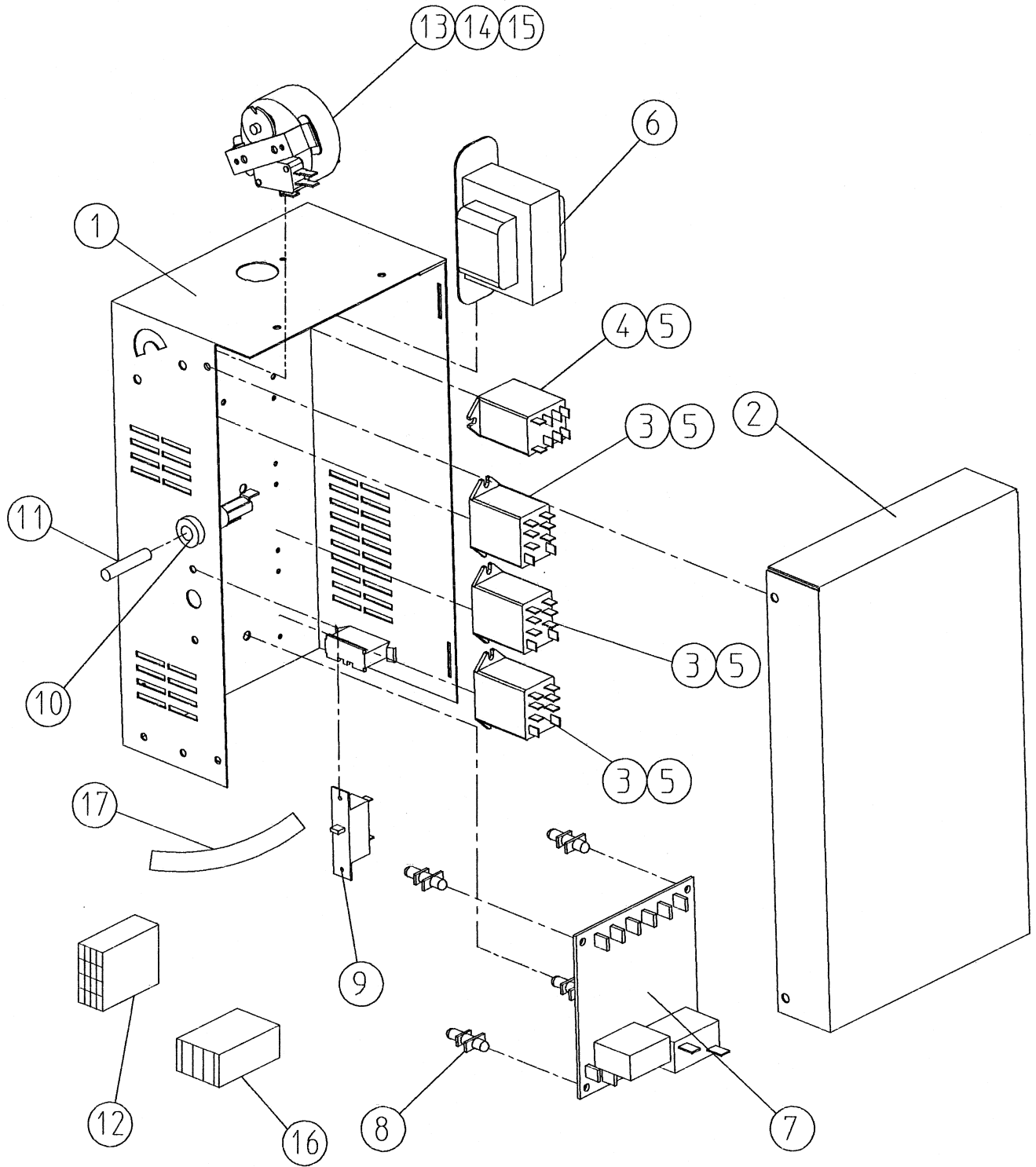

MODEL: <b>DCM-240BAF</b> TITLE: <b>F. CONTROL BOX (A) ASSEMBLY</b>											
INDEX NO.	DESCRIPTION	MATERIAL OR MODEL NUMBER	PART NUMBER	REQUIRED NUMBER							
				G-0	H-0	J-0	K-0	L-0			
1	CONTROL BOX (A)		2A0769-01	1	1	1	1	1			
2	CONTROL BOX COVER		3A0714-01	1	1	1	1	1			
	TRUSS HEAD SCREW	4 X 8	7C31-0408	2	2	2	2	2			
3	RELAY	LY2F 24V	406132-03	3	3	3	3	3			
4	RELAY	LY1F 120V	418271-03	1	1	1	1	1			
5	TAPPING SCREW		431415-01	8	8	8	8	8			
6	TRANSFORMER	BE141625GE K	4A0557-01	1	1	1	1	1			
	TRUSS HEAD SCREW	4 X 8	7C31-0408	2	2	2	2	2			
7	TIMER BOARD	H2AA144C02	437305-02	1	1	1	1	1			
8	BOARD SUPPORT		4A0336-03	4	4	4	4	4			
9	PROTECTOR	NW-3P-2 1.6A	427253-01	1	1	1	1	1			
	PAN HEAD SCREW	SS, 3 X 8	7C12-0308	2	2	2	2	2			
10	FUSEHOLDER	HTB921 250V 15A	4A0892-01	1	1	1	1	1			
11	FUSE	AGC-1 250V 1A	4A0893-01	1	1	1	1	1			
12	PLUG-0USING	3191-15P	412832-01	1	1	1	1	1			
13	TIMER	366-428 24V	4A0889-01	1	1	1	1	1			
14	SCREW	#6 - 32 X 3/8	4A0898-01	2	2	2	2	2			
15	CONNECTOR		4A0899-02	1	1	1	1	1			
16	PLUG-0USING	3191-04P	412832-05	1	1	1	1	1			
17	PVC TUBING	L=150	8104-0006	2	2	2	2	2			

HA

DCM-240BAF

G. CONTROL BOX (B) ASSEMBLY

G-0, H-0, J-0, K-0, L-0

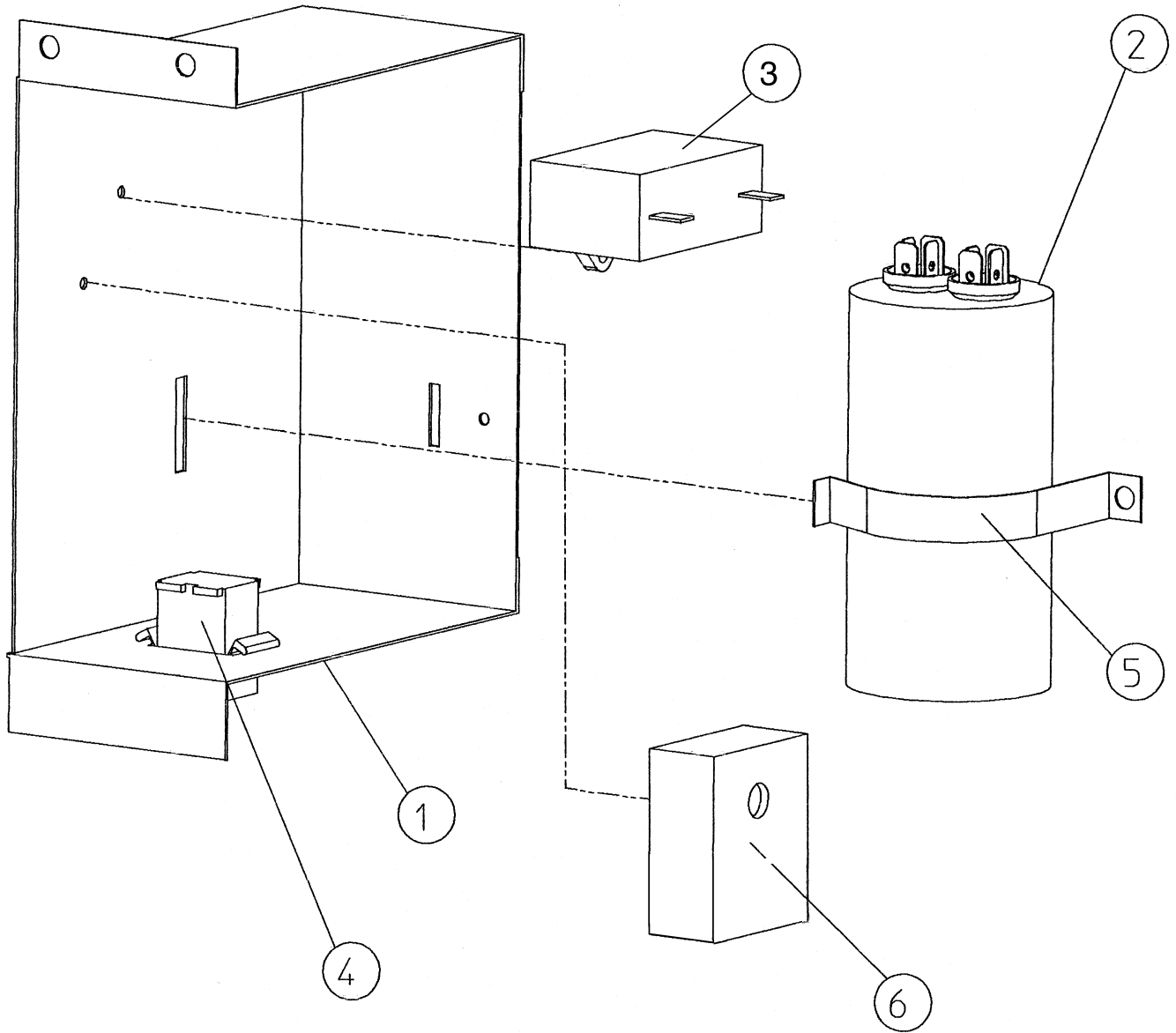



HA

MODEL: DCM-240BAF TITLE: G. CONTROL BOX (B) ASSEMBLY											
INDEX NO.	DESCRIPTION	MATERIAL OR MODEL NUMBER	PART NUMBER	REQUIRED NUMBER							
				G-0	H-0	J-0	K-0	L-0			
1	CONTROL BOX (B)		2A0771-01	1	1	1	1	1			
2	START CAPACITOR	145-174µf 250VAC	3A0076-11	1	1	1	1	1			
3	CAPACITOR	10µf 280V	416921-05	1	1	1	1	1			
	T2 SCREW	4 X 8	7P31-0408	1	1	1	1	1			
4	PLUG HOUSING	3191-06P	412832-03	1	1	1	1	1			
5	STRAP		434580-13	1	1	1	1	1			
	T2 SCREW	4 X 8	7P31-0408	1	1	1	1	1			
6	AGITATION TIMER		4A1137-01	1	1	1	1	1			
	TRUSS HEAD SCREW	4 X 20	7C31-0420	1	1	1	1	1			

HA

DCM-240BAF

H. MIDDLE FRONT PANEL ASSEMBLY

G-0, H-0, J-0, K-0, L-0

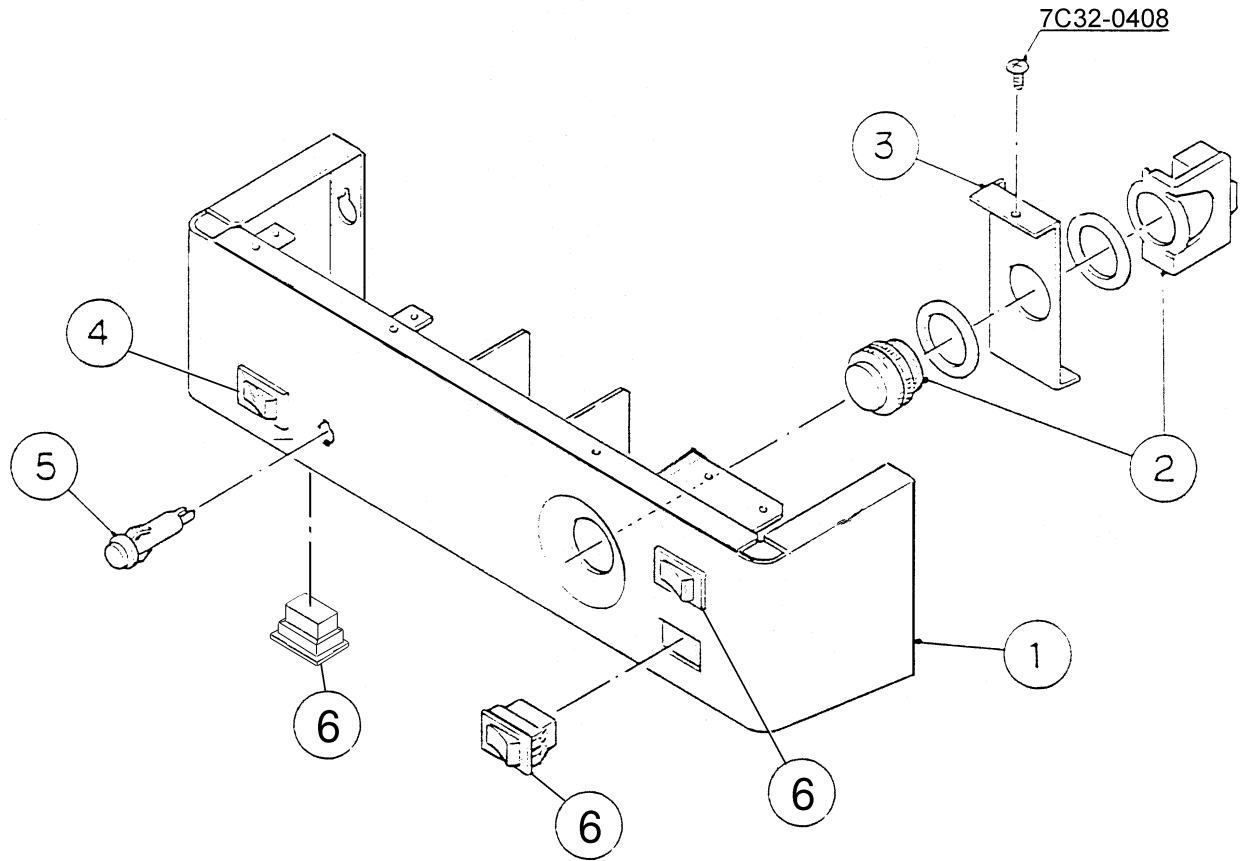

HA

MODEL: DCM-240BAF TITLE: H. MIDDLE FRONT PANEL ASSEMBLY									
INDEX NO.	DESCRIPTION	MATERIAL OR MODEL NUMBER	PART NUMBER	REQUIRED NUMBER					
				G-0	H00056M- H01105K	H01106L- H01205L	J-0	K-0	L-0
1	MIDDLE FRONT PANEL - PAINTED		3A0796G01	1	1	-			
			3A0796G02			1	1	1	1
2	PUSH SWITCH	2AP-1B	435745-02	1	1	1	1	1	1
3	SWITCH BRACKET		4A1207-01	1	1	1	1	1	1
	TRUSS HEAD SCREW	SS, 4 X 8	7C32-0408	3	3	3	3	3	3
4	ROCKER SWITCH	HLS112D	421491-08	1	1	1	1	1	1
5	LAMP		446400-01	1	1	-			
			4A1821-01			1	1	1	1
6	ROCKER SWITCH	HLS112A	421490-01	3	3	3	3	3	3

HA

DCM-240BAF

K. LABEL LOCATION

G-0, H-0, J-0, K-0, L-0

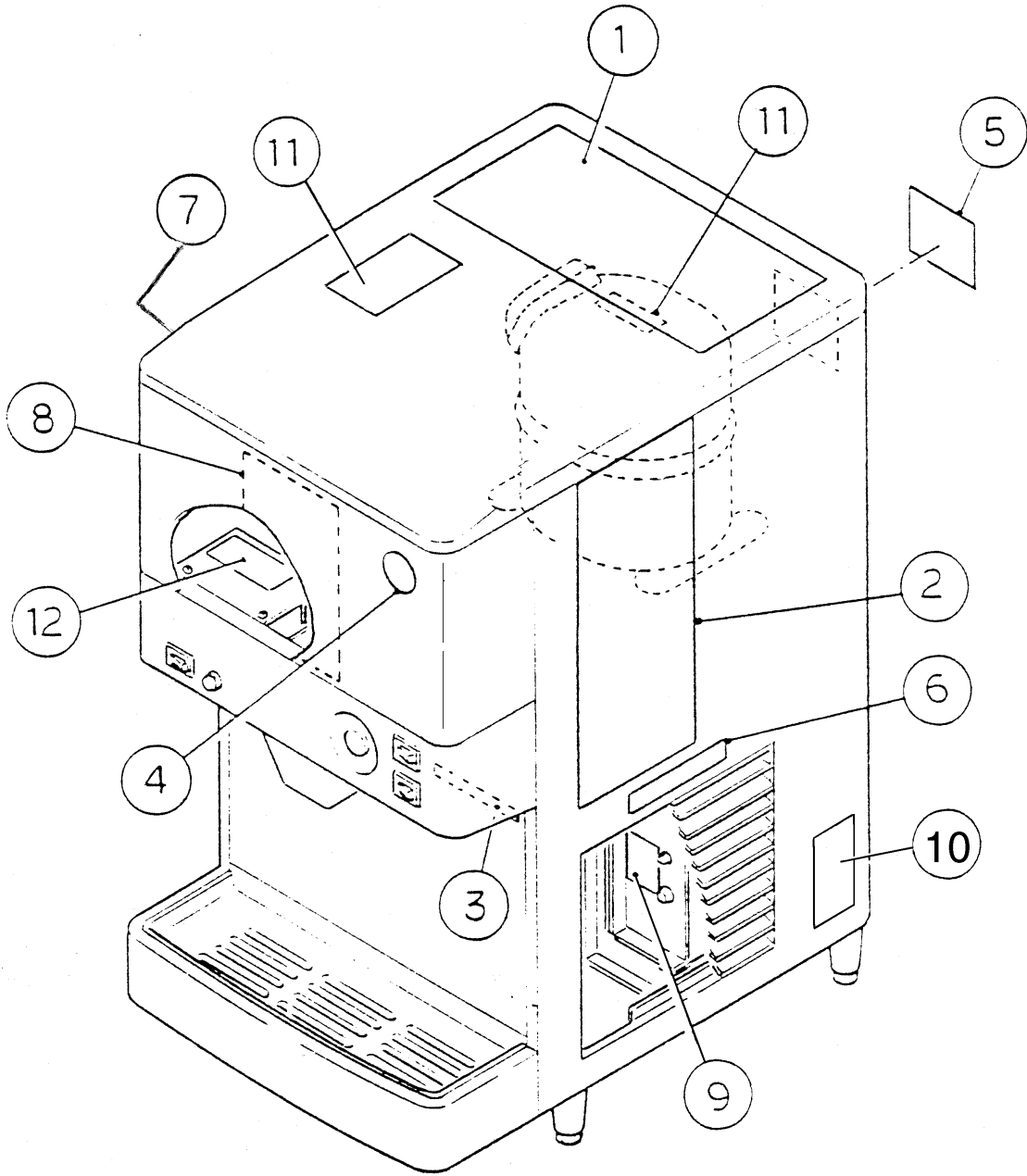

MODEL: <b>DCM-240BAF</b> TITLE: <b>K. LABEL LOCATION</b>											
INDEX NO.	DESCRIPTION	MATERIAL OR MODEL NUMBER	PART NUMBER	REQUIRED NUMBER							
				G-0	H-0	J-0	K-0	L-0			
1	INSTRUCTION SHEET		2A0849-01	1	1	1	1	1			
2	INSTRUCTION LABEL		2A0847-01	1	1	1	1	1			
3	MODEL NUMBER LABEL		4A0468-27	1	1	1	1	1			
4	LABEL - PENGUIN		4A0526-02	1	1	1	1	1			
5	NAME PLATE		4A1192-01	1	1	1	1	1			
6	LABEL - AIR FILTER		426177-01	1	1	1	1	1			
7	LABEL - CLEANING		2A0848-01	1	1	1	1	1			
8	WIRING LABEL		3A0784-01	1	1	1	1	1			
9	LABEL/RESET		4A1319-01	1	1	1	1	1			
10	CAUTION LABEL		441560-01	1	1	1	1	1			
11	LABEL - R404A		4A0960-01	2	2	2	2	2			
12	RATING LABEL		4A1698-01	1	1	1	1	1			

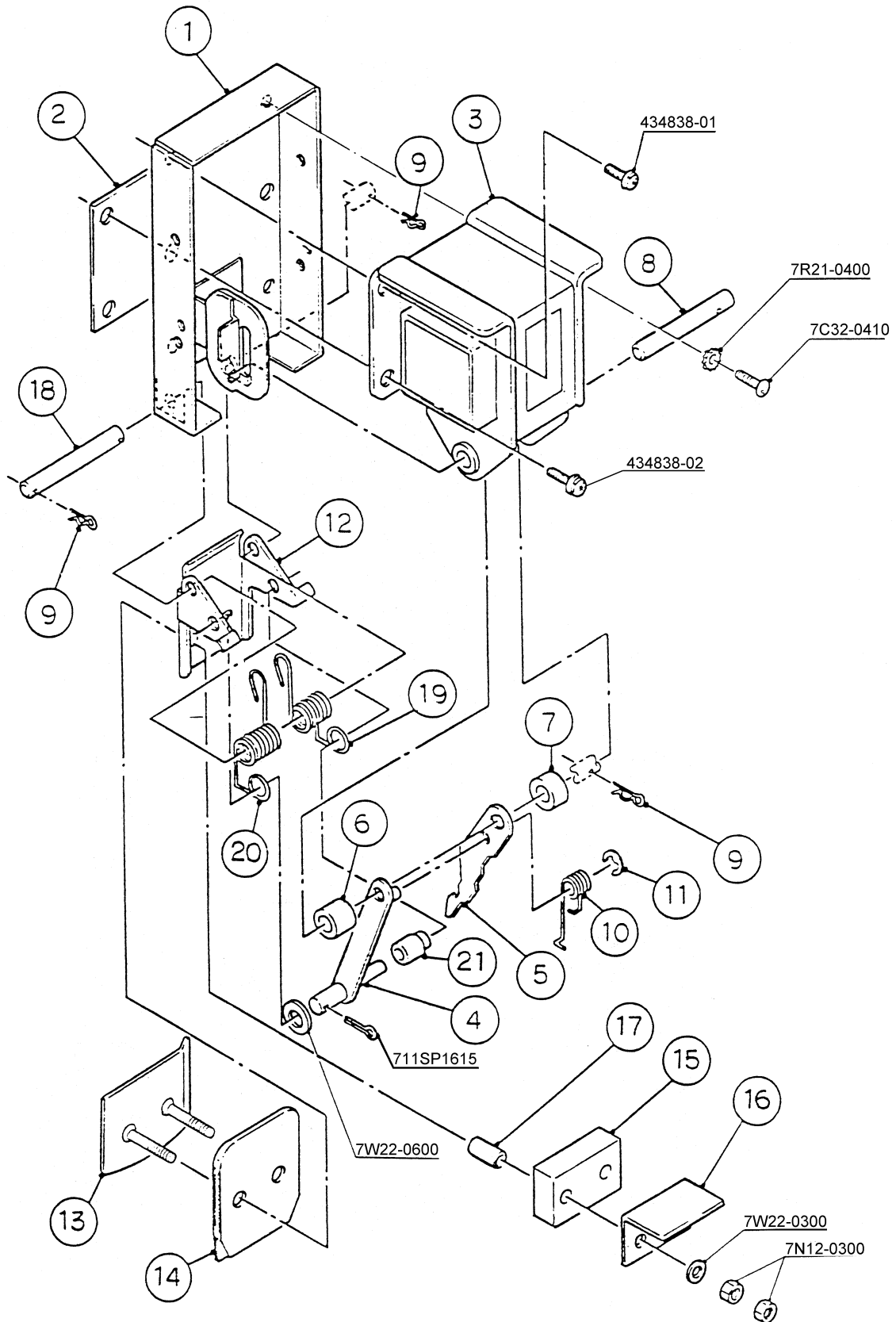

MODEL: DCM-240BAF TITLE: L. SHUTTER ASSEMBLY											
INDEX NO.	DESCRIPTION	MATERIAL OR MODEL NUMBER	PART NUMBER	REQUIRED NUMBER							
				G-0	H-0	J-0	K-0	L-0			
1	BRACKET - SOLENOID		320896G02	1	1	1	1	1			
2	SPACER	ABS (GRAY)	432514-01	1	1	1	1	1			
	SCREW	SS, 4 X 12	434838-02	4	4	4	4	4			
3	SOLENOID	AS-20-No. 75	437926-01	1	1	1	1	1			
	TRUSS HEAD SCREW	SS, 4 X 10	7C32-0410	1	1	1	1	1			
	TOOTH WASHER	M4	7R21-0400	1	1	1	1	1			
	SCREW	SS, 4 X 8	434838-01	1	1	1	1	1			
4	SHAFT		441645G01	1	1	1	1	1			
5	HOOK - SHUTTER		438406-01	1	1	1	1	1			
6	COLLAR (A)	ABS (GRAY)	432524-01	1	1	1	1	1			
7	COLLAR (B)	ABS (GRAY)	432524-02	1	1	1	1	1			
8	SHAFT (A) - SOLENOID		432517-02	1	1	1	1	1			
9	SNAP PIN	SS, SSP-5	715S-0005	3	3	3	3	3			
10	SPRING		411532-01	1	1	1	1	1			
11	"E" RING	SS, 4	721S-0004	1	1	1	1	1			
12	STOPPER		432518-03	1	1	1	1	1			
13	PLATE (A) - SHUTTER		423946G01	1	1	1	1	1			
14	PLATE (B) - SHUTTER		423948-01	1	1	1	1	1			
15	PLATE (C) - SHUTTER		419150-01	1	1	1	1	1			
16	PLATE (D) - SHUTTER		419151-01	1	1	1	1	1			
	PLAIN WASHER		7W22-0300	3	3	3	3	3			
	NUT		7N12-0300	4	4	4	4	4			
17	COLLAR (C) - SHUTTER		411539-03	2	2	2	2	2			
18	SHAFT (A)		432523-01	1	1	1	1	1			
	SPLIT PIN	SS, 1.6 X 15	711SP1615	1	1	1	1	1			
	PLAIN WASHER	SS, 6	7W22-0600	1	1	1	1	1			
19	SPRING (R)		434478-01	1	1	1	1	1			
20	SPRING (L)		434479-01	1	1	1	1	1			
21	SHAFT (B2)		432520-02	1	1	1	1	1			

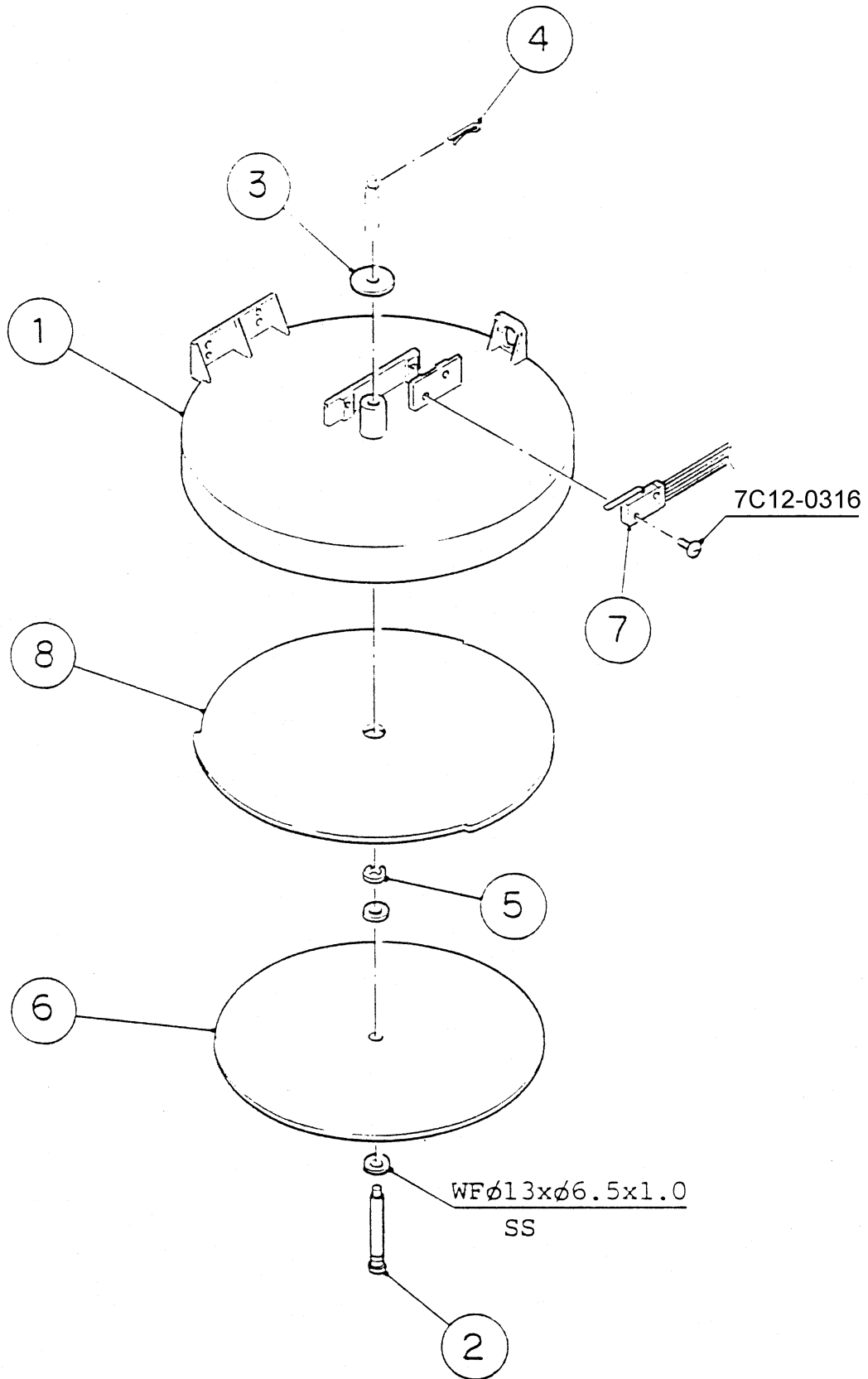



MODEL: DCM-240BAF TITLE: M COVER ASSEMBLY - BIN TOP											
INDEX NO.	DESCRIPTION	MATERIAL OR MODEL NUMBER	PART NUMBER	REQUIRED NUMBER							
				G-0	H-0	J-0	K-0	L-0			
1	COVER - BIN TOP		103829G01	1	1	1	1	1			
2	SHAFT		423958-01	1	1	1	1	1			
3	BALANCE PLATE		423959-01	1	1	1	1	1			
4	SNAP PIN	SS, SSP-4	715S-0004	1	1	1	1	1			
5	"E" RING	SS, 5	721S-0005	1	1	1	1	1			
6	BALANCE PLATE		417473-02	1	1	1	1	1			
7	MICRO SWITCH	V-5L11155W	423950-01	1	1	1	1	1			
	PAN HEAD SCREW	SS, 3 X 16	7C12-0316	2	2	2	2	2			
8	INSIDE PLATE	ABS (AM-1101-FA)	207830-01	1	1	1	1	1			

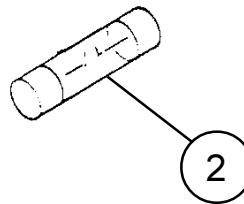
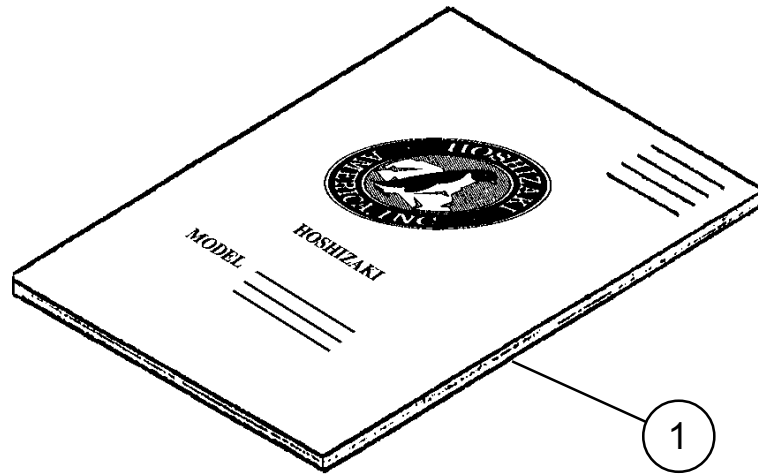

HA

MODEL: DCM-240BAF TITLE: N. ACCESSORIES											
INDEX NO.	DESCRIPTION	MATERIAL OR MODEL NUMBER	PART NUMBER	REQUIRED NUMBER							
				G-0	H-0	J-0	K-0	L-0			
1	INSTRUCTION MANUAL	PAPER	91A2AA10A	1	1	1	1	1			
2	FUSE		4A0893-01	1	1	1	1	1			