

NO. 71084

ISSUED: NOV. 19, 1998

REVISED: OCT. 13, 1999



**HOSHIZAKI  
CUBELET ICE DISPENSER**

**MODEL**

**DCM-450BAE (HA)**

**DCM-450BWE (HA)**

**PARTS LIST**

**DCM-450BAE**

**G-0 Dec., 1996**  
**G-1 June, 1997**  
**H-0 Dec., 1997**

**DCM-450BWE**

**G-0 Dec., 1996**  
**G-1 June, 1997**  
**H-0 Jan., 1998**

## MATERIAL ABBREVIATIONS

### ALUMINUM

AL = Aluminum

### COPPER

CU = Copper

### PLASTIC

ABS = Acrylonitrile -butadiene - styrene  
 AC = Polyacetal  
 EVA = Ethylene vinyl acetate  
 PA = Polyamide = Nylon  
 PC = Polycarbonate  
 PE = Polyethylene  
 PES = Polyester  
 PETP = Polyethylene terephthalate = Tetlon  
 PP = Polypropylene  
 PS = Polystyrene  
 PTFE = Polytetrafluoroethylene = Teflon  
 PUR = Polyurethane  
 PVC = Polyvinyl chloride

### RUBBER

VN = Vinyl Nitrile  
 EPDM = EP rubber  
 NBR = Nitrile butadiene rubber  
 NR = Natural rubber  
 NP = Neoprene  
 SIR = Silicone rubber  
 SYR = Synthetic rubber  
 EPH = Epichlorohydrin

### STEEL

GS = Galvanized steel  
 SS = Stainless steel  
 PS = Plated steel  
 PAS = Primed steel

## AUXILIARY CODE

Ex.1

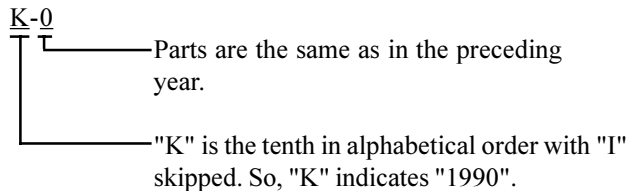

(Note) - = Part deleted.

x = Part deleted and replaced by "o" part.

o = New part for "x" in the same auxiliary code.

Ex.2

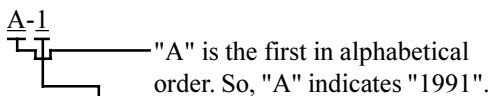

Ex.3

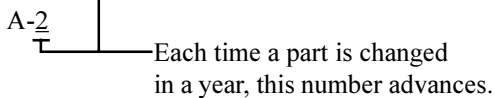

## FASTENER ABBREVIATION LIST

ST	Phillips Truss Machine Screw
SP	Phillips Pan Head Machine Screw
SF	Phillips Flat Head Machine Screw
SS	Phillips Pan Head Machine Screw with Split Lock Washer
SW	Phillips Pan Head Machine Screw with Split Lock Washer and Flat Washer
T1	Phillips Truss Head Tapping Screw (Correspond to Type A)
T2	Phillips Truss Head Tapping Screw (Correspond to Type B)
T3	Phillips Truss Head Tapping Screw (Correspond to Type C)
FT	Phillips Truss Head Tapping Screw (Special)
BH	Hexagon Head Bolt
BC	Socket Head Cap Screw
BS	Hexagon Bolt with Split Washer
BW	Hexagon Bolt with Split Washer and Flat Washer
BF	Hexagon Flange Bolt
BR	Cross-Recessed Hexagon Head Bolt
BRW	Cross-Recessed Hexagon Head Bolt with Split Lock Washer and Flat Washer
WL	Split Lock Washer
WT	External Tooth Washer
WF	Flat Washer
WS	Spring Washer
NH	Hexagon Nut
NF	Hexagon Flange Nut
NC	Hexagon Cap Nut
NS	Square Nut
NW	Wing Nut

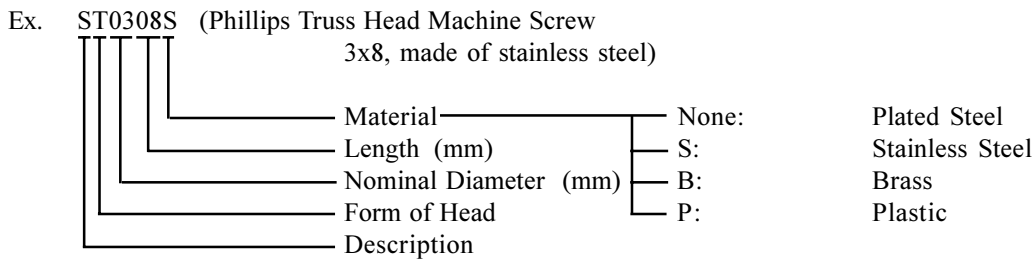

(Note) Second character is numerical except toe list.

Ex. S1, S2, B3 etc.

And abbreviations and names are shown under the illustration.

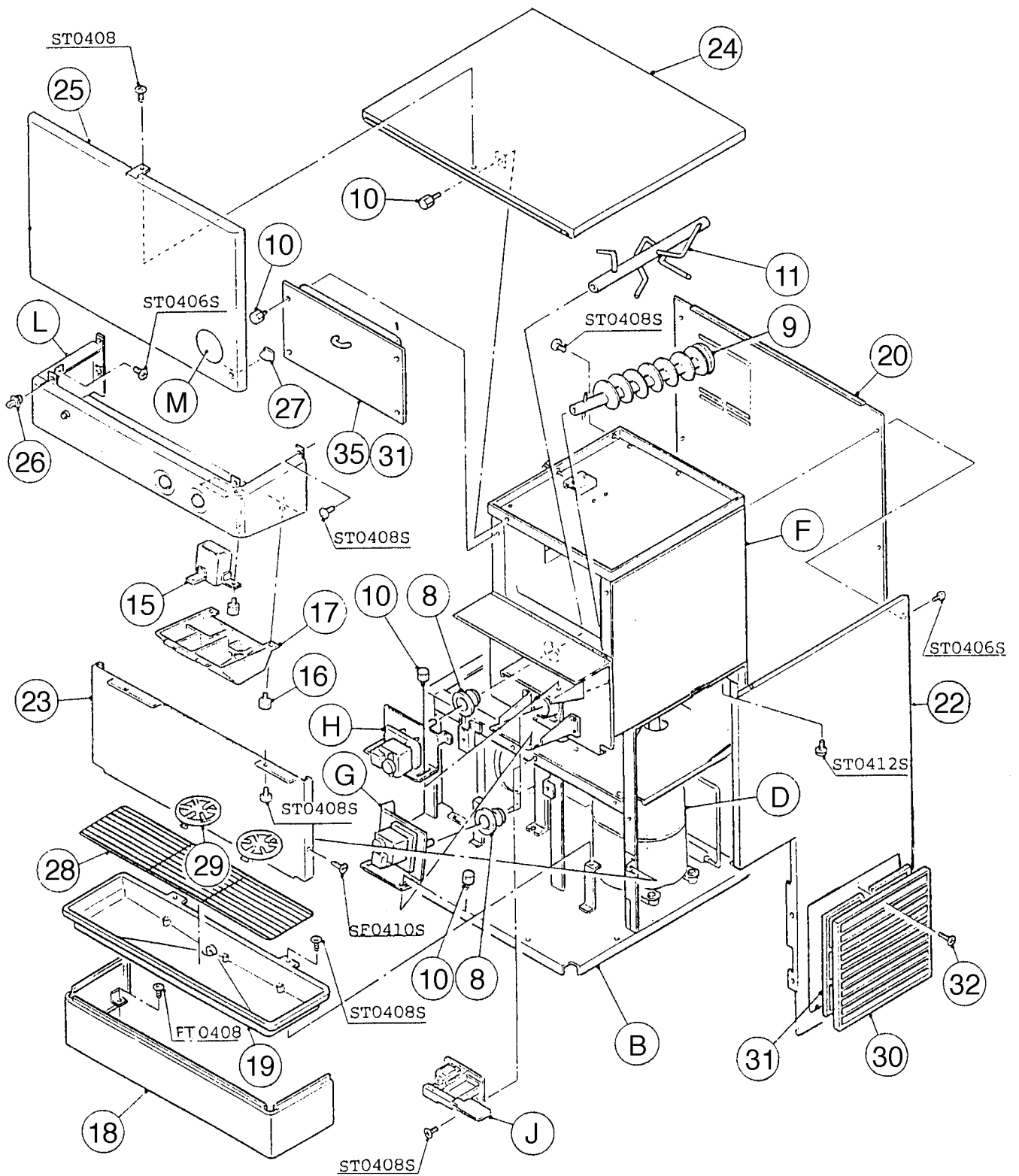

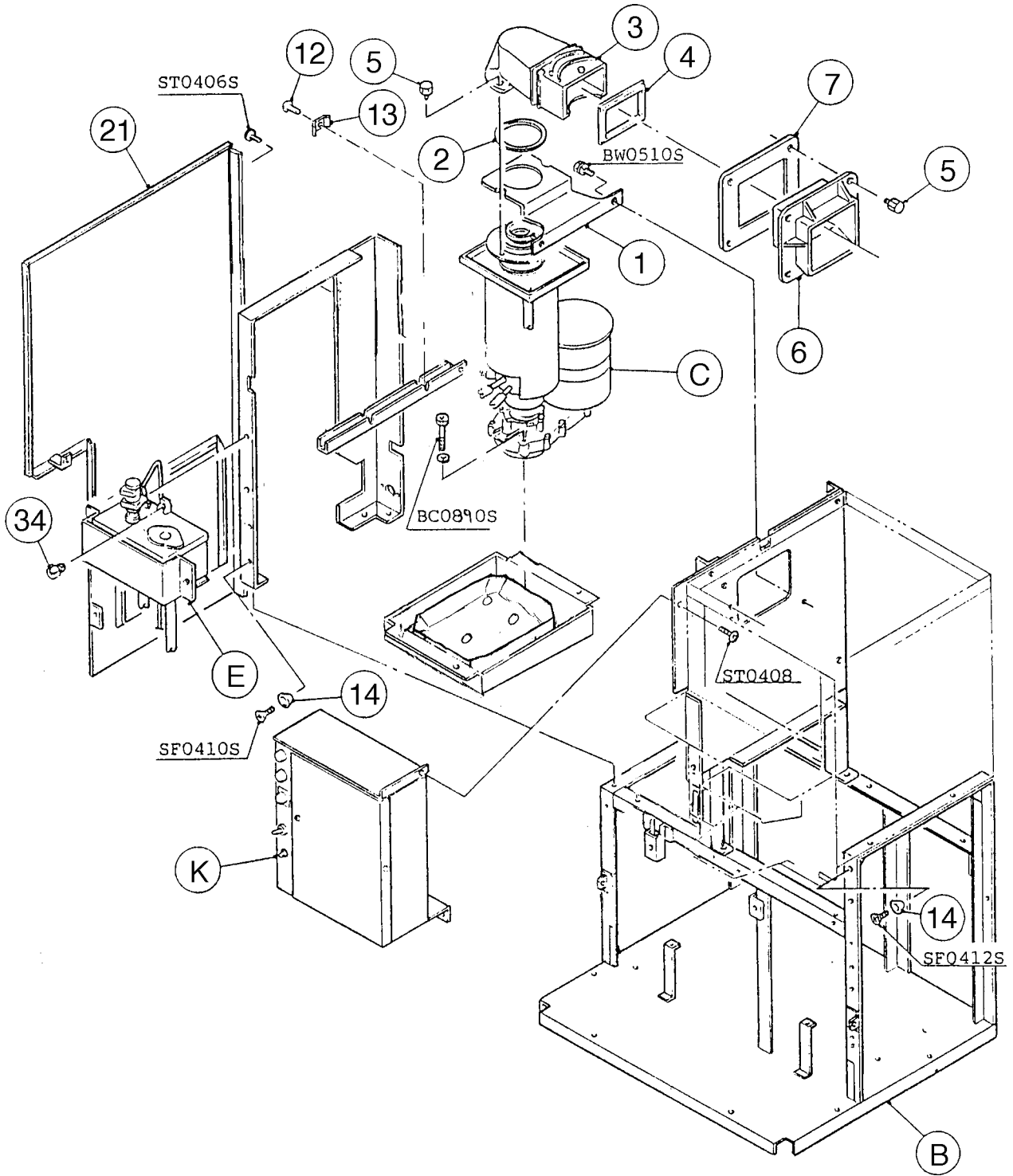

**MODEL: DCM-450BAE TITLE: A. ICE DISPENSER ASSEMBLY**

INDEX NO.	DESCRIPTION	MATERIAL OR MODEL NUMBER	PART NUMBER	REQUIRED NUMBER								
				G-0	G-1	H-0						
B	FRAME ASSEMBLY	-	2A0388A01	1	1	1						
C	EVAPORATOR ASSEMBLY	-	213831A02	1	1	1						
	SOCKET HEAD HEX BOLT	SS, 8 X 90	<a href="#">7S12-0890</a>	3	3	3						
	SPLIT LOCK WASHER	SS, 8	<a href="#">7L22-0800</a>	3	3	3						
D	REFRIGERATION CIRCUIT	-	2A0393A01	1	1	1						
E	WATER CIRCUIT	-	2A0395A01	1	1	1						
F	BIN ASSEMBLY	-	<a href="#">2A0413A01</a>	1	1	1						
	TRUSS HEAD SCREW	SS, 4 X 8	<a href="#">7C32-0408</a>	3	3	3						
	TRUSS HEAD SCREW	4 X 12	<a href="#">7C31-0412</a>	2	2	2						
G	GEAR MOTOR ASSEMBLY	-	<a href="#">4A0622A01</a>	1	1	1						
H	GEAR MOTOR ASSEMBLY	-	<a href="#">4A0620A01</a>	1	1	1						
J	SHUTTER ASSEMBLY	-	<a href="#">2A0410A01</a>	1	1	1						
	TRUSS HEAD SCREW	SS, 4 X 8	<a href="#">7C32-0408</a>	2	2	2						
K	CONTROL BOX ASSEMBLY	-	2A0390A01									
	TRUSS HEAD SCREW	4 X 8	<a href="#">7C31-0408</a>	3	3	3						
L	MIDDLE FRONT PANEL ASSEMBLY	-	2A0409A01	1	1	1						
	TRUSS HEAD SCREW	SS, 4 X 8	<a href="#">7C32-0408</a>	2	2	2						
M	LABEL LOCATION	-	2A0407A01	1	1	1						
1	BRACKET - EVAPORATOR		<a href="#">3A0360-01</a>	1	1	1						
	HEX HEAD BOLT W/WASHER (LF)	SS, 5 X 10	<a href="#">7B0230510</a>	2	2	2						
2	PACKING		<a href="#">427151-02</a>	1	1	1						
3	SPOUT		<a href="#">103329G01</a>	1	1	1						
4	PACKING (A) - SPOUT		<a href="#">427195-01</a>	1	1	1						
5	THUMBSCREW		<a href="#">415949G03</a>	7	7	7						
6	SPOUT (B)		<a href="#">208807-01</a>	1	1	1						
7	PACKING(B) - SPOUT		<a href="#">427196-01</a>	1	1	1						

**MODEL: DCM-450BAE TITLE: A. ICE DISPENSER ASSEMBLY**

INDEX NO.	DESCRIPTION	MATERIAL OR MODEL NUMBER	PART NUMBER	REQUIRED NUMBER								
				G-0	G-1	H-0						
8	GASKET		429758-01	2	2	2						
9	AUGER		319014G01	1	1	x1						
			339192G01			o1						
10	THUMBSCREW		415949G05	11	11	11						
11	AGITATOR		319018G01	1	x1							
			3A0895G01		o1	1						
12	SCREW - GROUNDING		433304-02	1	1	1						
13	WASHER		433537-02	1	1	1						
14	COLLAR		4H0171-01	2	2	2						
	FLAT HEAD SCREW	SS, 4 X 12	7C22-0412	2	2	2						
15	ICE CHUTE		439788G01	1	1	1						
16	THUMBSCREW		415949G08	4	4	4						
17	SPOUT COVER		215773-01	1	1	1						
18	PANEL (LO)		2A0699G01	1	1	1						
	FT SCREW	SS, 4 X 8	7F32-0408	6	6	6						
19	TRAY - DRIP		105219G01	1	1	1						
	TRUSS HEAD SCREW	SS, 4 X 8	7C32-0408	4	4	4						
20	REAR PANEL		2A0405-01	1	1	1						
	TRUSS HEAD SCREW	SS, 4 X 8	7C32-0408	4	4	4						
21	SIDE PANEL (L)		2A0696-01	1	1	1						
	TRUSS HEAD SCREW	SS, 4 X 8	7C32-0408	6	6	6						
22	SIDE PANEL (R)		2A0695-01	1	1	1						
	TRUSS HEAD SCREW	SS, 4 X 8	7C32-0408	6	6	6						
23	APRON PANEL		2A0720-01	1	1	1						
	TRUSS HEAD SCREW	SS, 4 X 8	7C32-0408	2	2	2						
	FLAT HEAD SCREW	SS, 4 X 12	7C22-0412	2	2	2						
24	TOP PANEL		3A0640G01	1	1	1						
25	FRONT PANEL		3A0638G01	1	1	1						
	TRUSS HEAD SCREW	SS, 4 X 8	7C32-0408	1	1	1						





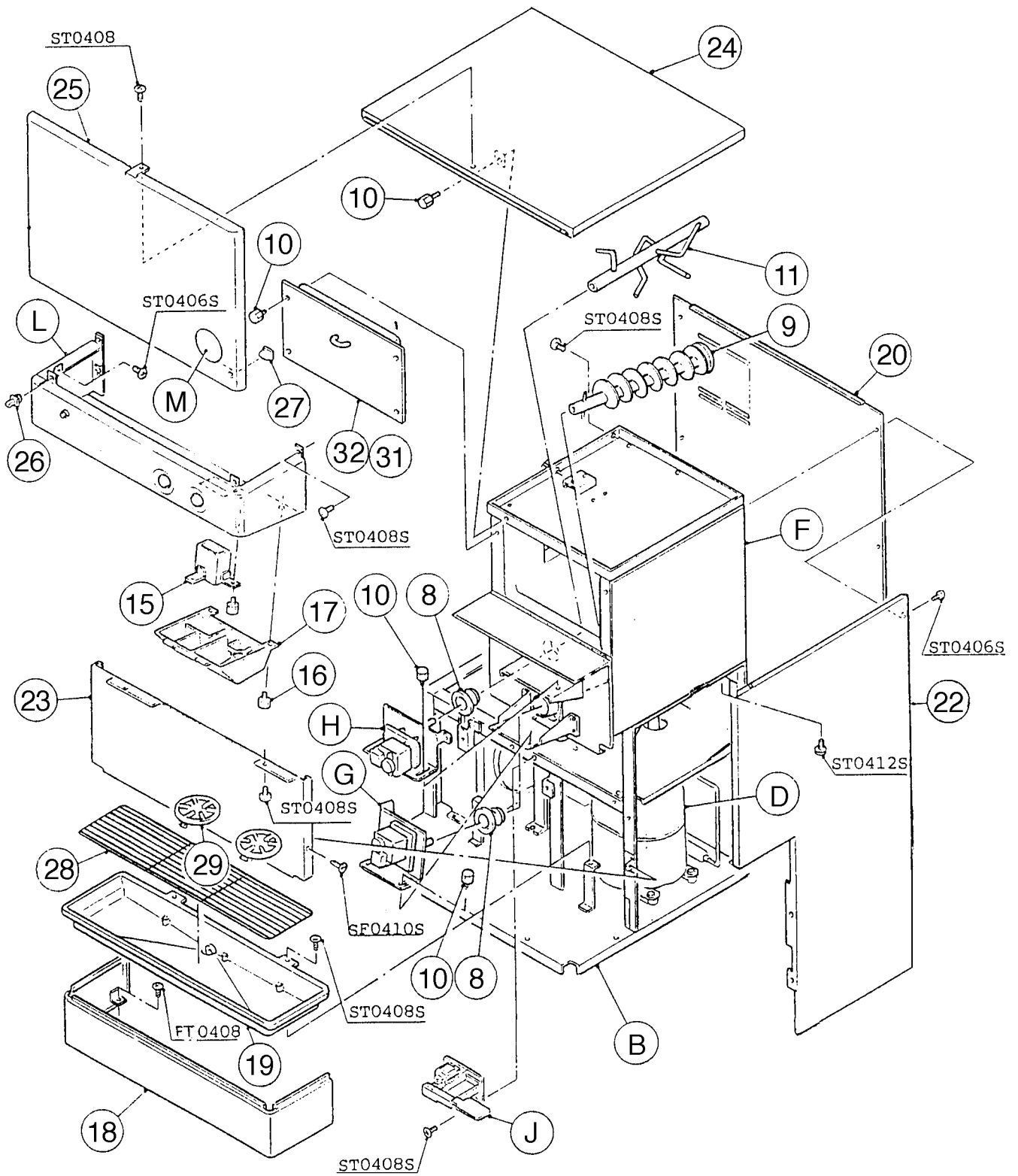

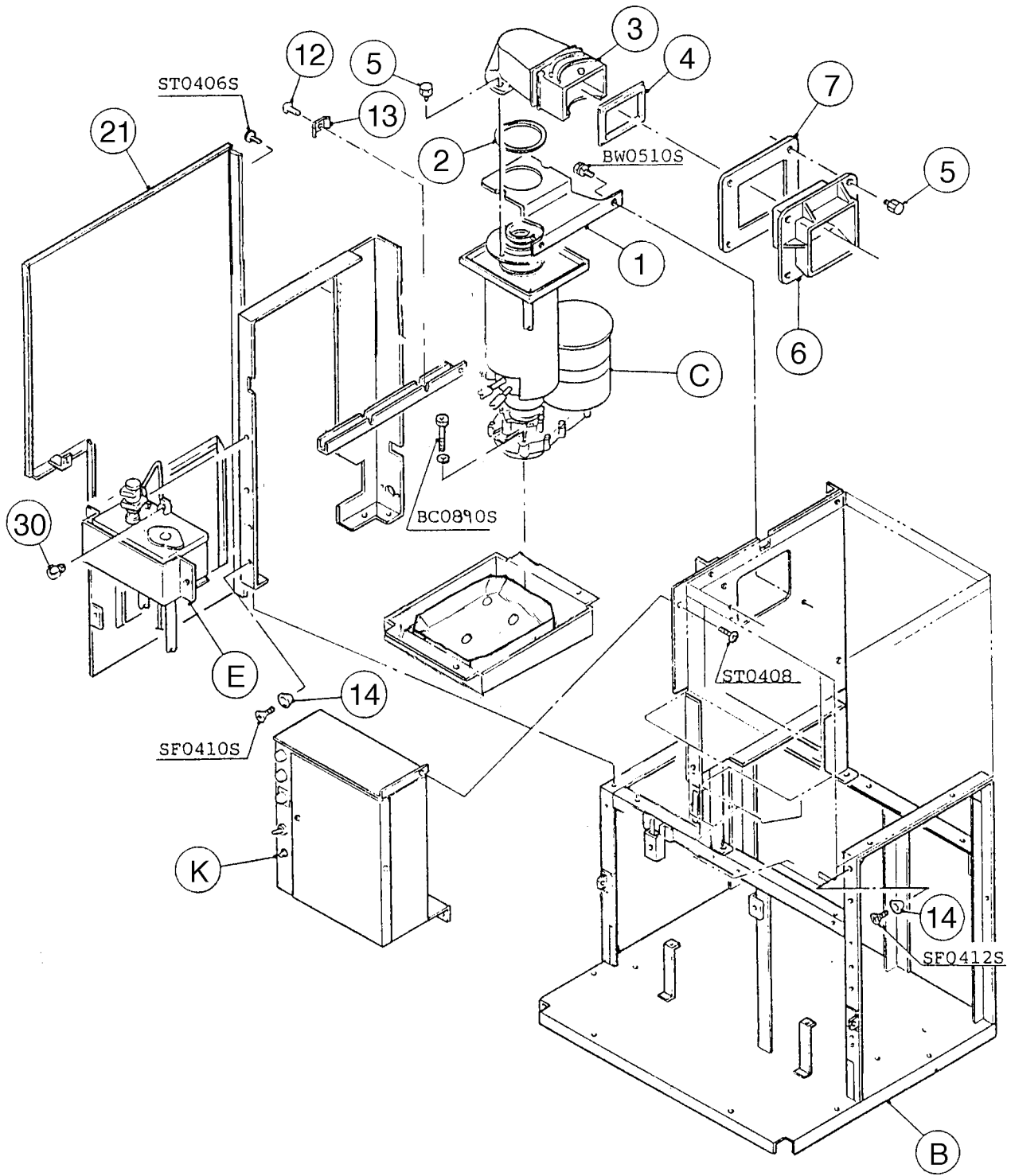

**MODEL: DCM-450BWE TITLE: A. ICE DISPENSER ASSEMBLY**

INDEX NO.	DESCRIPTION	MATERIAL OR MODEL NUMBER	PART NUMBER	REQUIRED NUMBER								
				G-0	G-1	H-0						
B	FRAME ASSEMBLY		2A0388A01	1	1	1						
C	EVAPORATOR ASSEMBLY		213831A02	1	1	1						
	SOCKET HEAD HEX BOLT	SS, 8 X 90	7S12-0890	3	3	3						
	SPLIT LOCK WASHER	SS, 8	7L22-0800	3	3	3						
D	REFRIGERATION CIRCUIT		2A0394A01	1	1	1						
E	WATER CIRCUIT		2A0395A01	1	1	1						
F	BIN ASSEMBLY		2A0413A01	1	1	1						
	TRUSS HEAD SCREW	SS, 4 X 8	7C32-0408	3	3	3						
	TRUSS HEAD SCREW	4 X 12	7C31-0412	2	2	2						
G	GEAR MOTOR ASSEMBLY	-	4A0622A01	1	1	1						
H	GEAR MOTOR ASSEMBLY	-	4A0620A01	1	1	1						
J	SHUTTER ASSEMBLY	-	2A0410A01	1	1	1						
	TRUSS HEAD SCREW	SS, 4 X 8	7C32-0408	2	2	2						
K	CONTROL BOX ASSEMBLY	-	2A0390A02									
	TRUSS HEAD SCREW	4 X 8	7C31-0408	3	3	3						
L	MIDDLE FRONT PANEL ASSEMBLY		2A0409A01	1	1	1						
	TRUSS HEAD SCREW	SS, 4 X 8	7C32-0408	2	2	2						
M	LABEL LOCATION		2A0407A02	1	1	1						
1	BRACKET - EVAPORATOR		3A0360-01	1	1	1						
	HEX HEAD BOLT W/WASHER (LF)	SS, 5 X 10	7B0230510	2	2	2						
2	PACKING		427151-02	1	1	1						
3	SPOUT		103329G01	1	1	1						
4	PACKING (A) - SPOUT		427195-01	1	1	1						
5	THUMBSCREW		415949G03	7	7	7						
6	SPOUT (B)		208807-01	1	1	1						
7	PACKING(B) - SPOUT		427196-01	1	1	1						

**MODEL: DCM-450BWE TITLE: A. ICE DISPENSER ASSEMBLY**

INDEX NO.	DESCRIPTION	MATERIAL OR MODEL NUMBER	PART NUMBER	REQUIRED NUMBER							
				G-0	G-1	H-0					
8	GASKET		<a href="#">429758-01</a>	2	2	2					
9	AUGER		<a href="#">319014G01</a>	1	1	x1					
			<a href="#">339192G01</a>			o1					
10	THUMBSCREW		<a href="#">415949G05</a>	11	11	11					
11	AGITATOR		<a href="#">319018G01</a>	1	x1						
			<a href="#">3A0895G01</a>		o1	1					
12	SCREW - GROUNDING		<a href="#">433304-02</a>	1	1	1					
13	WASHER		<a href="#">433537-02</a>	1	1	1					
14	COLLAR		<a href="#">4H0171-01</a>	2	2	2					
	FLAT HEAD SCREW	SS, 4 X 12	<a href="#">7C22-0412</a>	2	2	2					
15	ICE CHUTE		<a href="#">439788G01</a>	1	1	1					
16	THUMBSCREW		<a href="#">415949G08</a>	4	4	4					
17	SPOUT COVER		<a href="#">215773-01</a>	1	1	1					
18	PANEL (LO)		<a href="#">2A0699G01</a>	1	1	1					
	FT SCREW	SS, 4 X 8	<a href="#">7F32-0408</a>	6	6	6					
19	TRAY - DRIP		<a href="#">105219G01</a>	1	1	1					
	TRUSS HEAD SCREW	SS, 4 X 8	<a href="#">7C32-0408</a>	4	4	4					
20	REAR PANEL		<a href="#">2A0404-01</a>	1	1	1					
	TRUSS HEAD SCREW	SS, 4 X 8	<a href="#">7C32-0408</a>	4	4	4					
21	SIDE PANEL (L)		<a href="#">2A0698-01</a>	1	1	1					
	TRUSS HEAD SCREW	SS, 4 X 8	<a href="#">7C32-0408</a>	6	6	6					
22	SIDE PANEL (R)		<a href="#">2A0697-01</a>	1	1	1					
	TRUSS HEAD SCREW	SS, 4 X 8	<a href="#">7C32-0408</a>	6	6	6					
23	APRON PANEL		<a href="#">2A0720-01</a>	1	1	1					
	TRUSS HEAD SCREW	SS, 4 X 8	<a href="#">7C32-0408</a>	2	2	2					
	FLAT HEAD SCREW	SS, 4 X 12	<a href="#">7C22-0412</a>	2	2	2					
24	TOP PANEL		<a href="#">3A0640G01</a>	1	1	1					
25	FRONT PANEL		<a href="#">3A0638G01</a>	1	1	1					
	TRUSS HEAD SCREW	SS, 4 X 8	<a href="#">7C32-0408</a>	1	1	1					



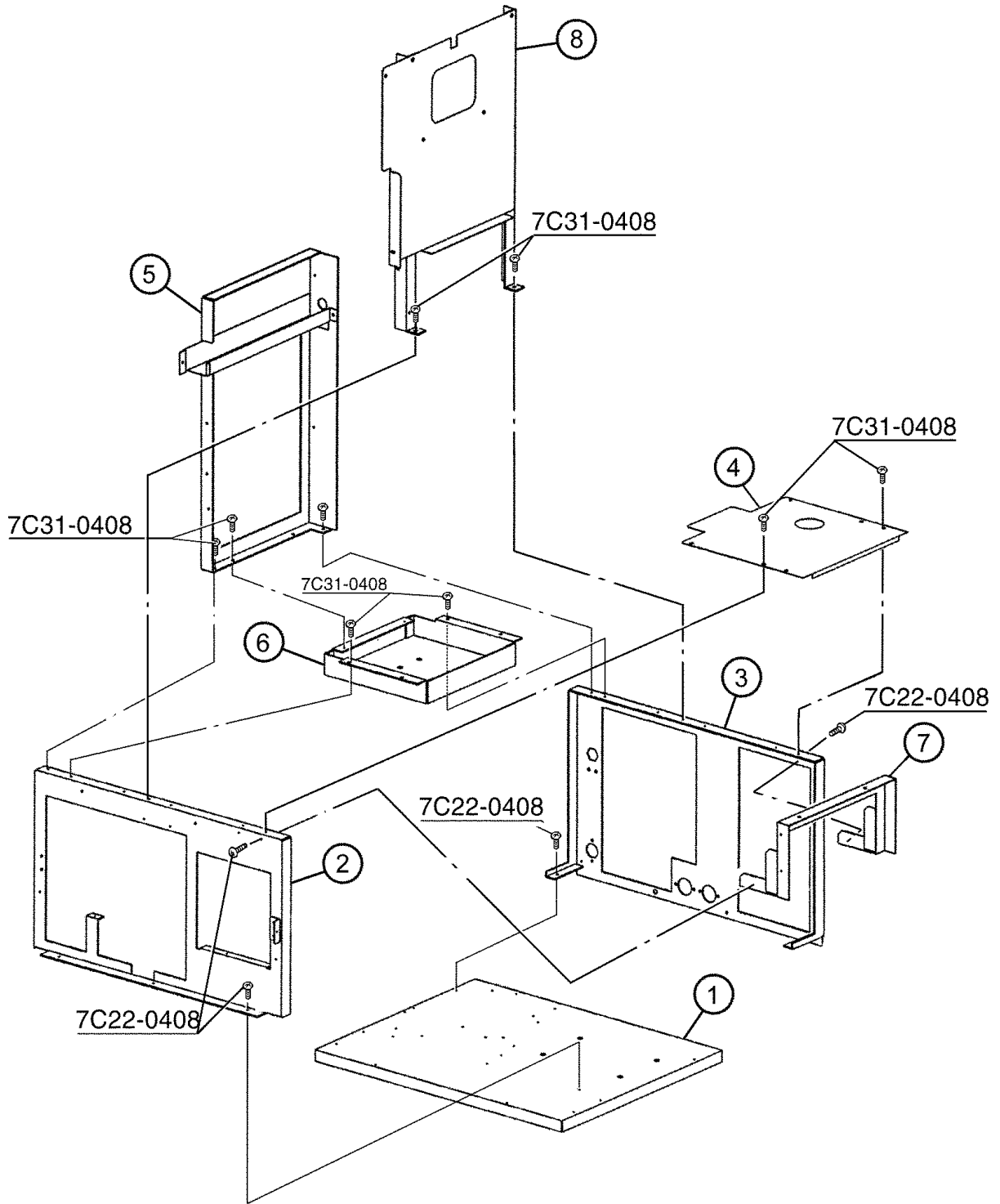

**MODEL: DCM-450BAE, BWE TITLE: B. FRAME ASSEMBLY**

INDEX NO.	DESCRIPTION	MATERIAL OR MODEL NUMBER	PART NUMBER	REQUIRED NUMBER									
				G-0	G-1	H-0							
1	BASE		3A0614G01	1	1	1							
2	FRONT FRAME		2A0665G01	1	1	1							
	FT SCREW	SS, 4 X 8	7C22-0408	3	3	3							
3	REAR FRAME		2A0666-01	1	1	1							
	FT SCREW	SS, 4 X 8	7C22-0408	3	3	3							
4	SEPARATOR		3A0615-01	1	1	1							
	TRUSS HEAD SCREW	4 X 8	7C31-0408	2	2	2							
5	SIDE FRAME (R)		3A0355G01	1	1	1							
	TRUSS HEAD SCREW	4 X 8	7C31-0408	4	4	4							
6	DRAIN PAN		2A0677G01	1	1	1							
	TRUSS HEAD SCREW	4 X 8	7C31-0408	4	4	4							
7	SIDE FRAME (UP)		3A0616G01	1	1	1							
	TRUSS HEAD SCREW	4 X 8	7C31-0408	4	4	4							
8	CENTER PANEL		3A0617G01	1	1	1							
	TRUSS HEAD SCREW	4 X 8	7C31-0408	2	2	2							



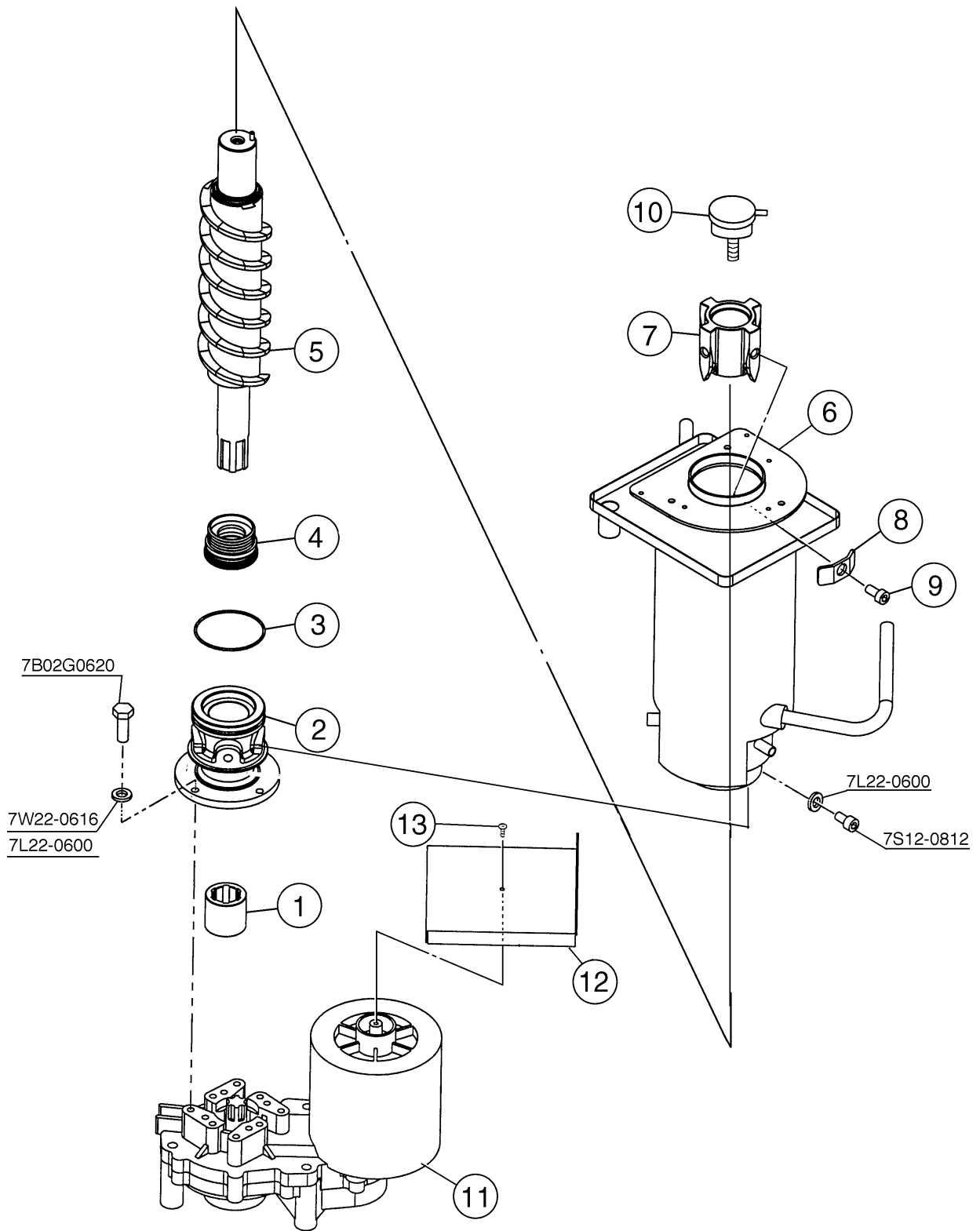

**MODEL: DCM-450BAE, BWE TITLE: C. EVAPORATOR ASSEMBLY**

INDEX NO.	DESCRIPTION	MATERIAL OR MODEL NUMBER	PART NUMBER	REQUIRED NUMBER								
				G-0	G-1	H-0						
1	COUPLING – SPLINE		418316-01	1	1	1						
2	HOUSING		214938G01	1	1	1						
	HEX BOLT (GOLD STAINLESS)	6 X 20	7B02G0620	4	4	4						
	PLAIN WASHER		7W22-0616	4	4	4						
	SPLIT LOCK WASHER	SS, 6	7L22-0600	4	4	4						
3	“O” RING	G65	7616-G065	2	2	2						
4	MECHANICAL SEAL	HK9A-MN DIAM 30	432492-01	1	1	1						
5	AUGER		216337G02	1	1	1						
6	EVAPORATOR		319154G02	1	1	1						
	SOCKET HEAD CAP SCREW	SS, 8 X12		4	4	4						
	SPLIT LOCK WASHER	8		4	4	4						
7	EXTRUDING HEAD – 70C		216530G01	1	1	1						
8	WASHER		427184-01	4	4	4						
9	SOCKET HEAD CAP SCREW	SS, 8 X 14	429121-01	4	4	4						
10	CUTTER		427183G01	1	1	1						
11	GEAR MOTOR		4A0897-01	1	1	1						
12	MOTOR COVER		3A0622-01	1	1	1						
13	SCREW		4A0898-02	1	1	1						



**MODEL: DCM-450BAE TITLE: D. REFRIGERATION CIRCUIT**

INDEX NO.	DESCRIPTION	MATERIAL OR MODEL NUMBER	PART NUMBER	REQUIRED NUMBER							
				G-0	G-1	H-0					
1	COMPRESSOR		444624-01	1	1	1					
2	GROMMET		434403-01	4	4	4					
3	SPACER		434404-01	4	4	4					
4	PROTECTOR		444623-01	1	1	1					
5	PROTECTOR HOLDER		437379-01	1	1	1					
6	BOLT		437889-01	4	4	4					
7	CONDENSER		210104-02	1	1	1					
	FT SCREW	SS, 4 X 8	7F32-0408	2	2	2					
8	SHROUD		2A0728-01	1	1	1					
	T2 SCREW	4 X 8	7P31-0408	6	6	6					
9	FAN MOTOR BRACKET		3A0650-01	1	1	1					
10	FAN MOTOR		440911-01	1	1	1					
	HEX HEAD BOLT W/WASHER (LF)	SS, 5 X 12	7B0230512	4	4	4					
	SELF-LOCKING NUT	No. 8-32	7N21I0832	4	4	4					
11	COPPER TUBE	COPPER	3A0649G01	1	1	1					
12	COPPER TUBE	COPPER	4A0604-01	1	1	1					
13	COPPER TUBE	COPPER	2A0402G01	1	1	1					
14	FAN BLADE		444898-01	1	1	1					
15	VALVE - LIQUID INJECTION		4A0923-01	1	1	1					
16	COVER - LIQUID INJECTION VALVE (A)		3A0593-01	1	1	1					
17	COVER - LIQUID INJECTION VALVE (B)		3A0593-02	1	1	1					
18	DRIER		445006-01	1	1	1					
19	DRIER BRACKET		445847-01	1	1	1					
	FT SCREW	SS, 4 X 8	7F32-0408	1	1	1					
20	EXPANSION VALVE		443968-03	1	1	1					
21	EXP. VALVE COVER (A)		3A0555-01	1	1	1					



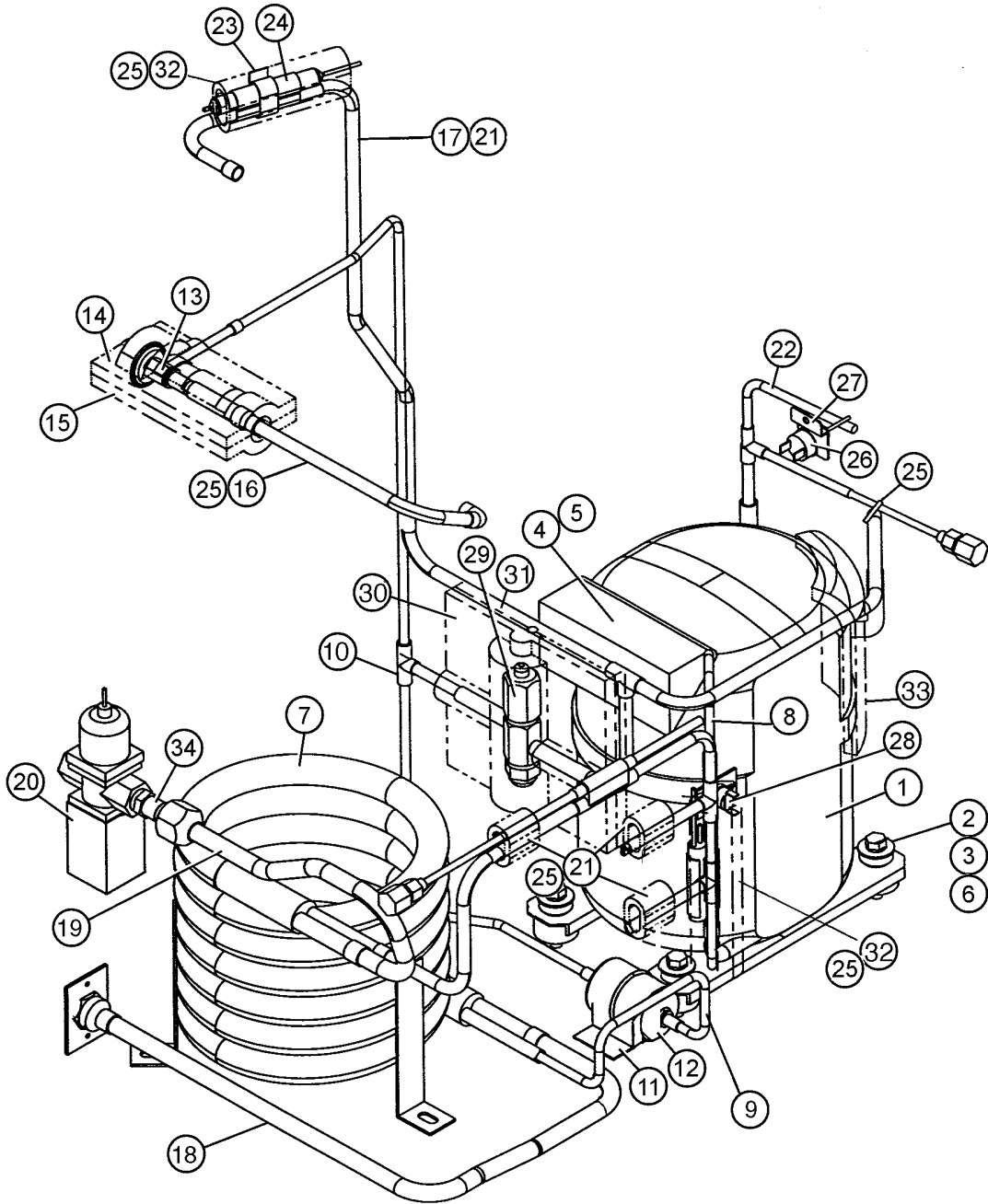

**MODEL: DCM-450BWE TITLE: D. REFRIGERATION CIRCUIT**

INDEX NO.	DESCRIPTION	MATERIAL OR MODEL NUMBER	PART NUMBER	REQUIRED NUMBER								
				G-0	G-1	H-0						
1	COMPRESSOR		444624-01	1	1	1						
2	GROMMET		434403-01	4	4	4						
3	SPACER		434404-01	4	4	4						
4	PROTECTOR		444623-01	1	1	1						
5	PROTECTOR HOLDER		437379-01	1	1	1						
6	BOLT		437889-01	4	4	4						
7	CONDENSER - WATER COOLED		212929-02	1	1	1						
	FT SCREW	SS, 4 X 8	7F32-0408	3	3	3						
8	COPPER TUBE		3A0654G01	1	1	1						
9	COPPER TUBE		4A0606-01	1	1	1						
10	COPPER TUBE		2A0402G01	1	1	1						
11	DRIER BRACKET		445847-01	1	1	1						
12	DRIER		445006-01	1	1	1						
	FT SCREW	SS, 4 X 8	7F32-0408	1	1	1						
13	EXPANSION VALVE		443968-03	1	1	1						
14	EXP. VALVE COVER (A)		3A0555-01	1	1	1						
15	EXP. VALVE COVER (B)		3A0555-02	1	1	1						
16	COPPER TUBE		4A0600G01	1	1	1						
17	COPPER TUBE		2A0401G01	1	1	1						
18	WATER TUBE		3A0652G01	1	1	1						
19	WATER TUBE		3A0653G01	1	1	1						
20	WATER REGULATOR		4A0911-01	1	1	-						
			4A0911-02			1						
	TRUSS HEAD SCREW	4 X 8	7C31-0408	2	2	2						
21	INSULATION TUBE	L=30	7762-0717	3	3	3						
22	COPPER TUBE - ACCESS VALVE		3A0651G01	1	1	1						
23	CLAMP		443461-02	2	2	2						





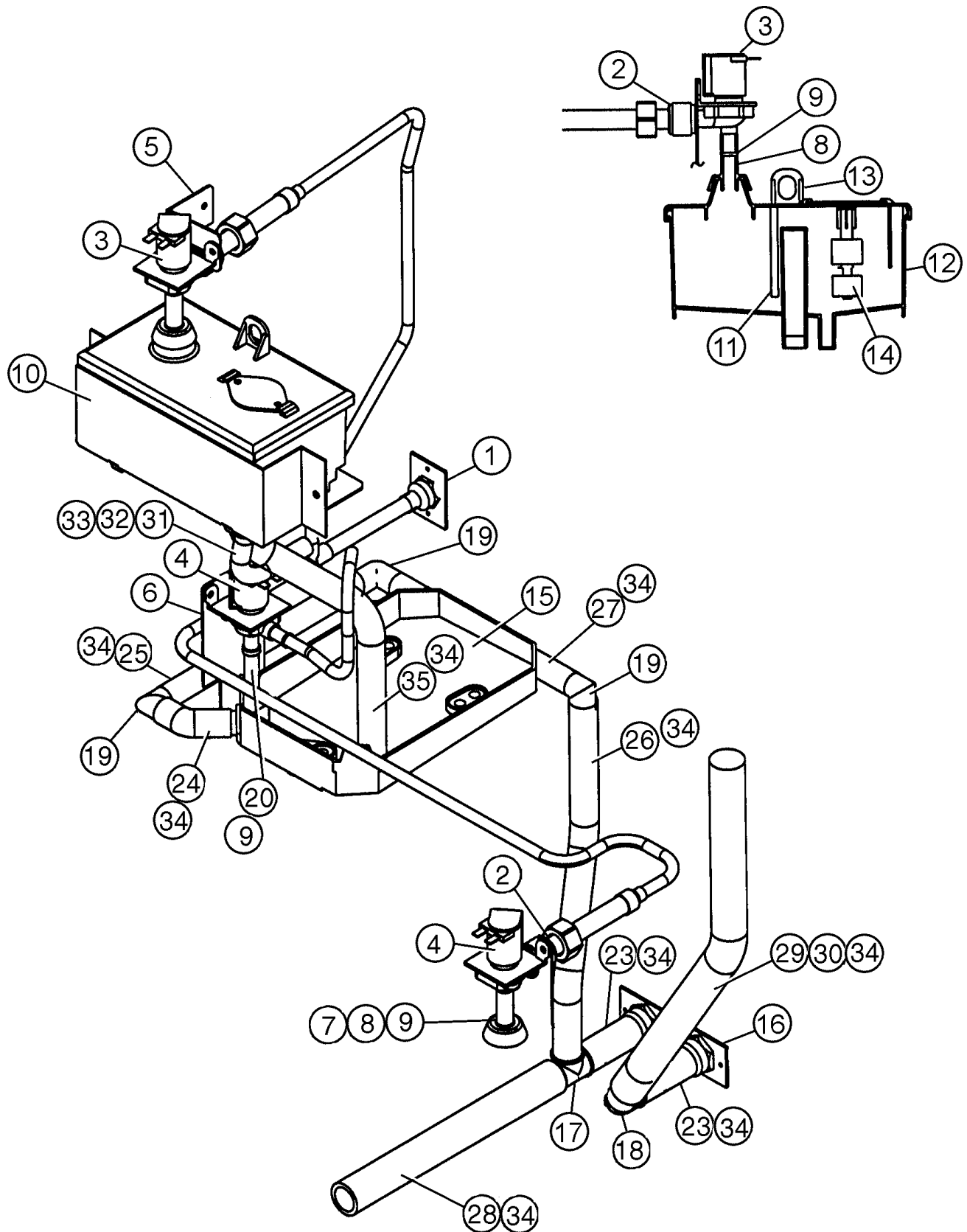

**MODEL: DCM-450BAE, BWE TITLE: E. WATER CIRCUIT**

INDEX NO.	DESCRIPTION	MATERIAL OR MODEL NUMBER	PART NUMBER	REQUIRED NUMBER							
				G-0	G-1	H-0					
1	WATER SUPPLY PIPE		2A0680G01	1	1	1					
	T2 SCREW	4 X 8	7P31-0408	2	2	2					
2	WASHER		4A0867-01	2	2	2					
3	WATER VALVE		4A0865-01	2	2	2					
4	WATER VALVE		4A0866-01	1	1	1					
	T2 SCREW	4 X 8	7P31-0408	6	6	6					
5	WATER VALVE BRACKET (A)		4A0997-01	1	1	1					
6	WATER VALVE BRACKET (B)		4A0998-01	1	1	1					
7	WATER VALVE BRACKET (C)		4A0999-01	1	1	1					
	T2 SCREW	4 X 8	7P31-0408	4	4	4					
	TRUSS HEAD SCREW	4 X 8	7C31-0408	2	2	2					
8	INLET - RESERVOIR		4A0869-01	1	2	2					
9	CLAMP		421642-04	5	5	5					
10	BRACKET - RESERVOIR		3A0356-01	1	1	1					
	TRUSS HEAD SCREW	4 X 8	7C31-0408	2	2	2					
11	SEPARATOR - RESERVOIR		4A1255-01		1	1					
12	RESERVOIR		214809-01	1	-						
			2A0753-01		1	1					
13	RESERVOIR COVER		214810-01	1	1	1					
14	FLOAT SWITCH		435490-01	1	1	1					
15	DRAIN PAN		323765G02	1	1	1					
16	FITTING		4A0776G01	2	2	2					
	T2 SCREW	4 X 8	7P31-0408	4	4	4					
17	TEE		4A0525-04	1	1	1					
18	ELBOW		4A1016-01	1	1	1					
19	ELBOW		4A1017-01	2	3	3					
20	VINYL HOSE	L=70	7716-0913	1	1	1					
21	VINYL HOSE	L=100	7725-0912	1	-						
22	VINYL HOSE	L=250	7725-0912	1	1	1					



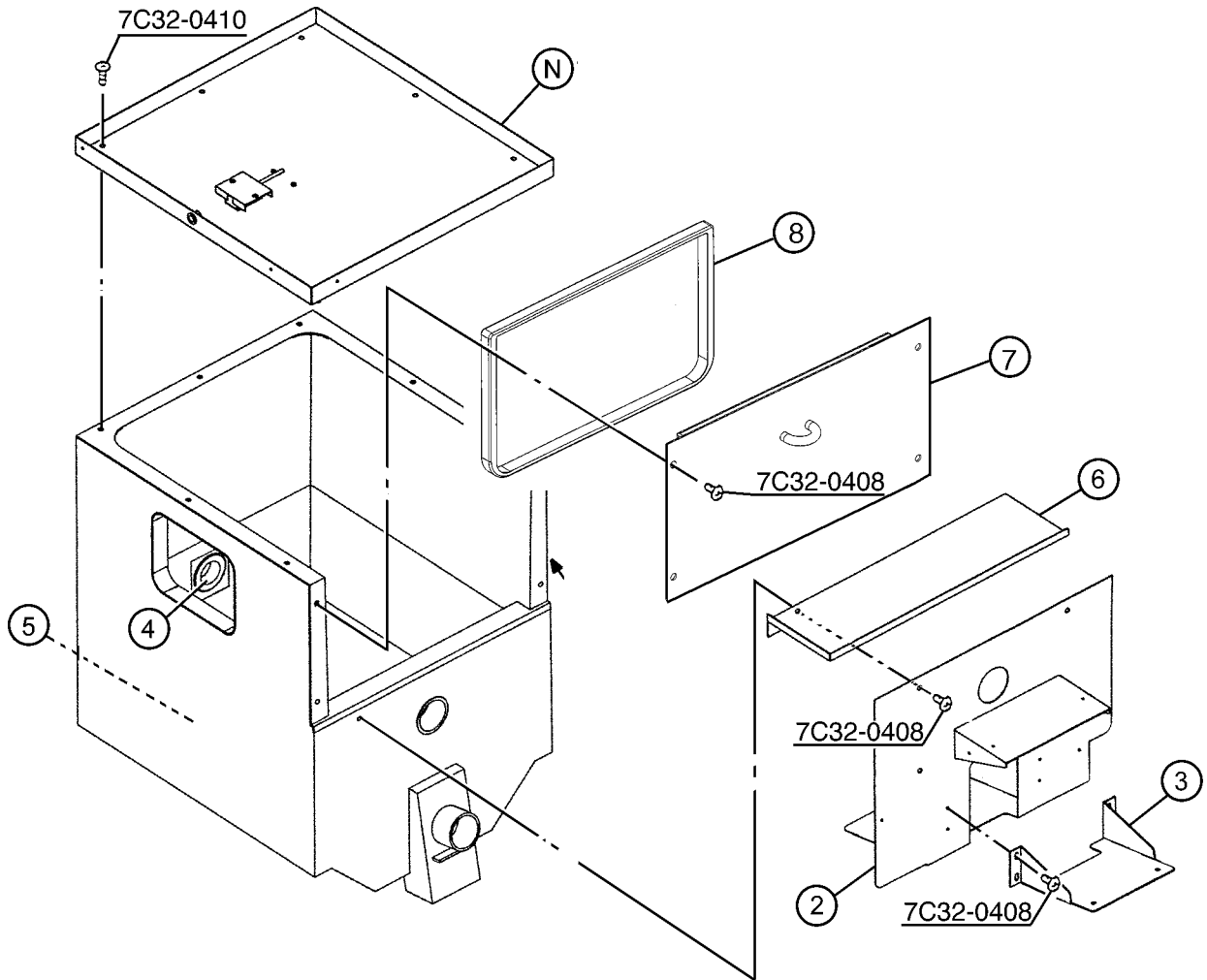



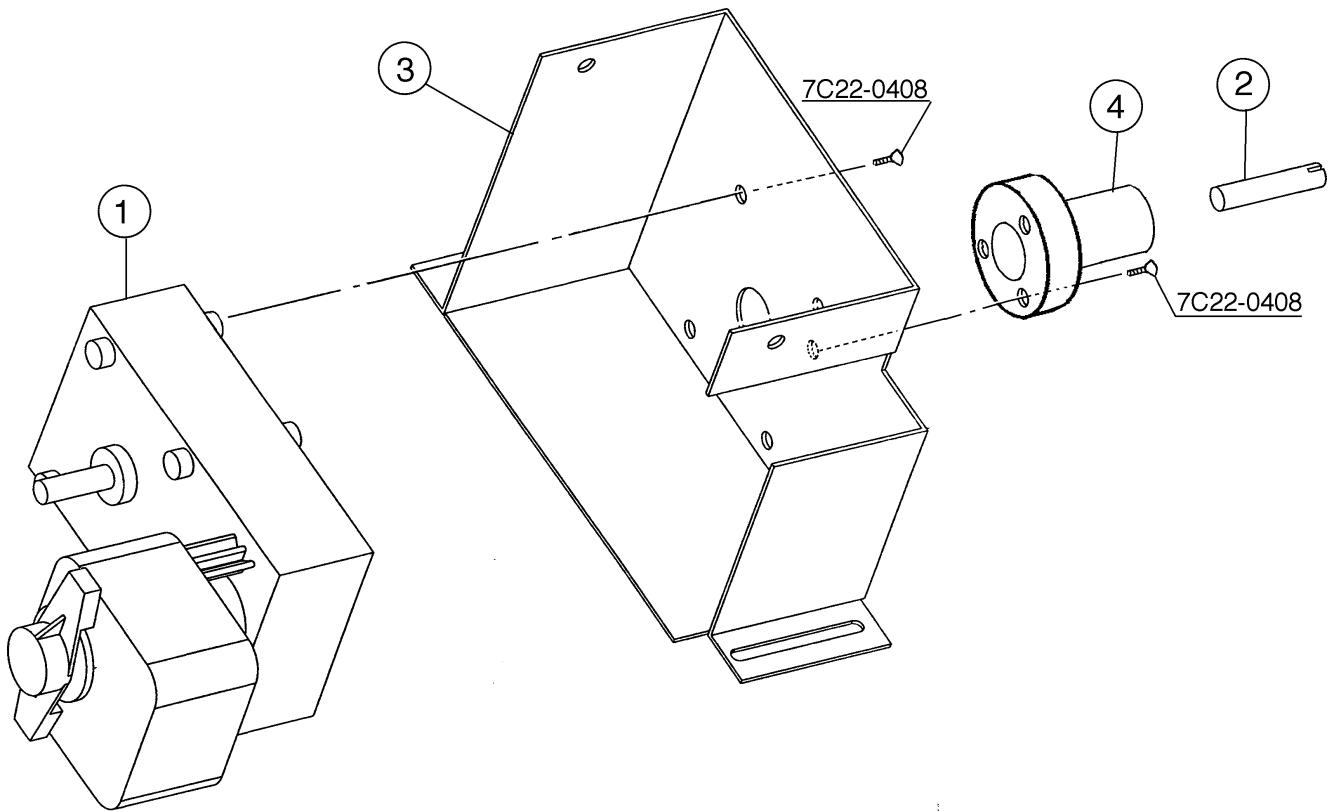



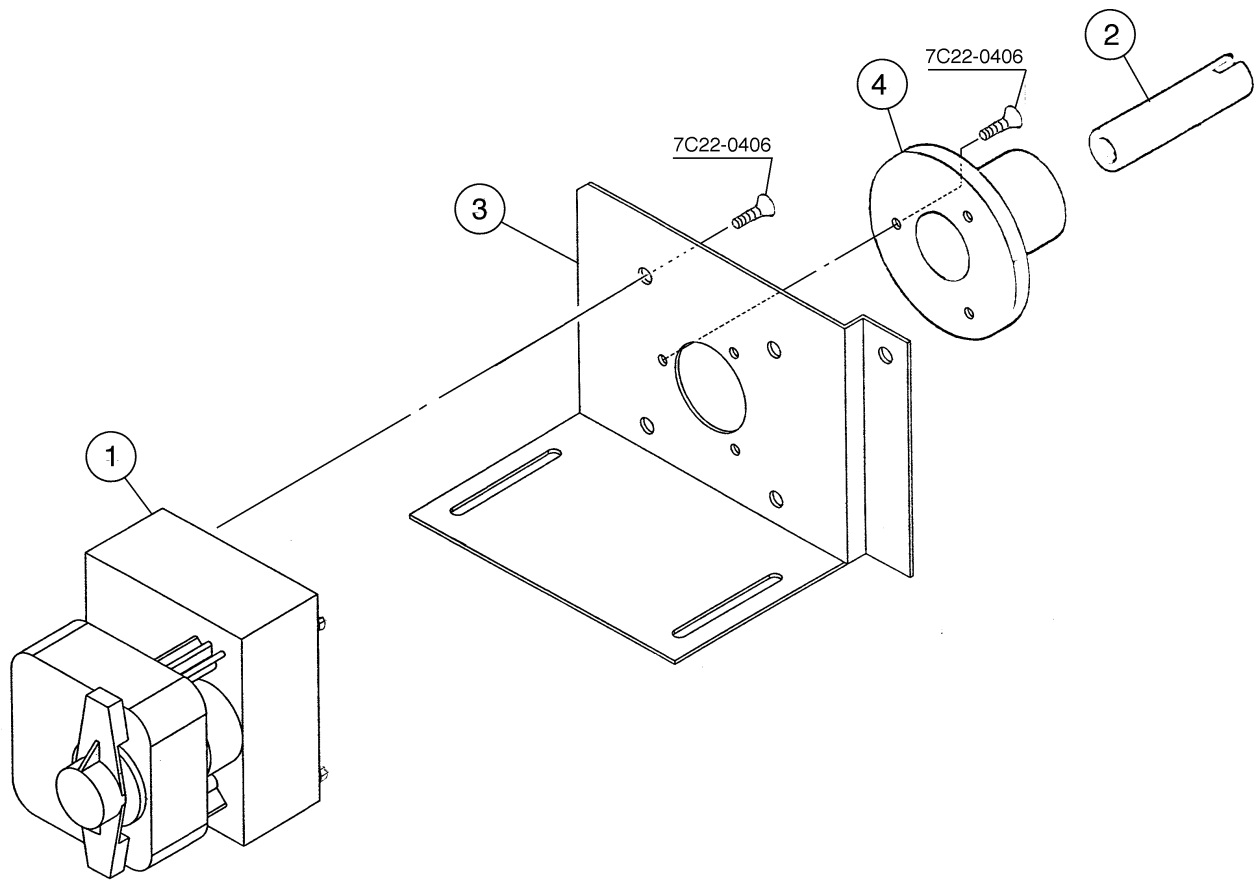





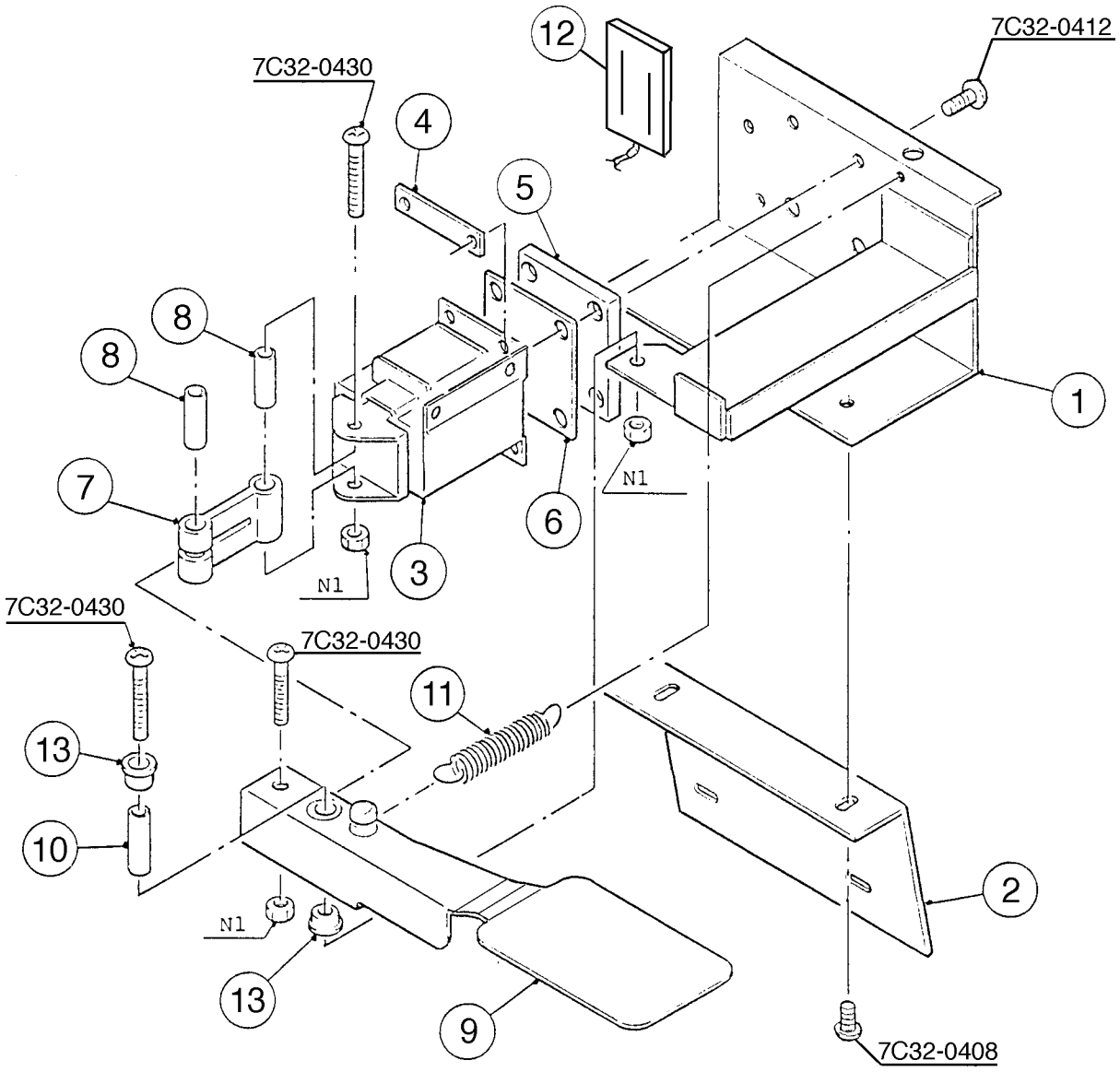



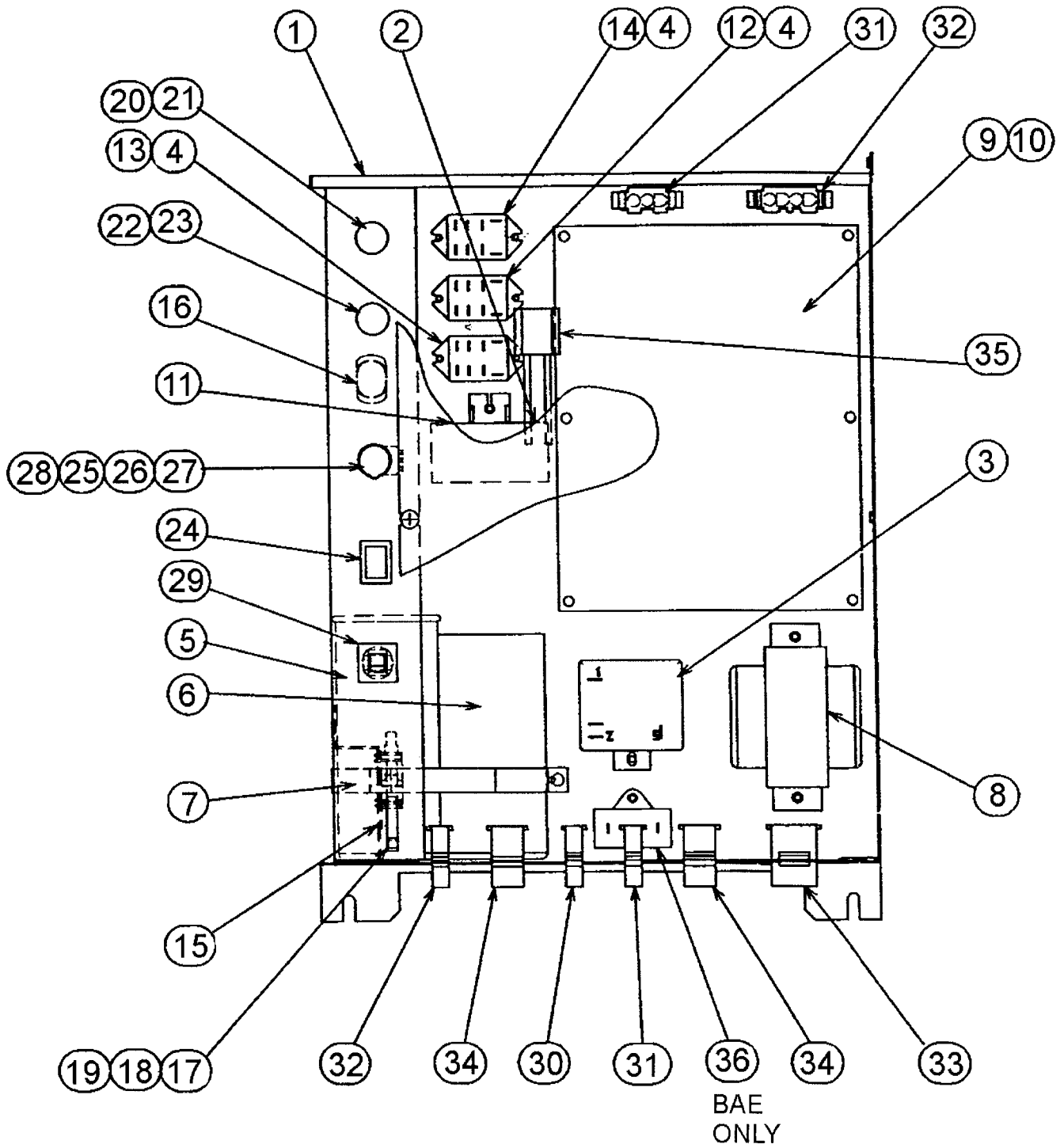

**MODEL: DCM-450BAE TITLE: K. CONTROL BOX ASSEMBLY**

INDEX NO.	DESCRIPTION	MATERIAL OR MODEL NUMBER	PART NUMBER	REQUIRED NUMBER							
				G-0	G-1	H-0					
1	CONTROL BOX		2A0391G01	1	1	1					
2	COVER - CONTROL BOX		429931-01	1	1	1					
	TRUSS HEAD SCREW	4 X 8	7C31-0408	2	2	2					
3	STARTER		434172-04	1	1	1					
4	TAPPING SCREW		431415-01	6	6	6					
5	CAPACITOR		439943-05	1	1	1					
6	CAPACITOR - STARTING		3A0076-06	1	1	1					
7	STRAP		434580-12	1	1	1					
	T2 SCREW	4 X 8	7P31-0408	2	2	2					
8	TRANSFORMER	TR5267-1	2U0042-02	1	1	1					
	T2 SCREW	4 X 8	7P31-0408	2	2	2					
9	TIMER BOARD		2U0098-02	1	1	1					
10	BOARD SUPPORT		4A0336-03	6	6	6					
11	CAPACITOR		4A0894-01	1	1	1					
	T2 SCREW	4 X 8	7P31-0408	1	1	1					
12	RELAY		418271-03	1	1	1					
13	RELAY		418271-05	1	1	1					
14	RELAY		406132-03	1	1	1					
15	SWITCH BRACKET		4A1013-01	1	1	1					
	T2 SCREW	4 X 8	7P31-0408	2	2	2					
16	BUSHING		420472-03	1	1	1					
17	MICROSWITCH		4A0365-01	1	1	1					
18	SPACER		429933-01	2	2	2					
19	TAPPING SCREW		431415-02	2	2	2					
20	FUSE HOLDER		4A0892-01	1	1	1					
21	FUSE		4A0893-01	1	1	1					
22	FUSE HOLDER		4A0892-02	1	1	1					
23	FUSE		4A0893-02	1	1	1					
24	ROCKER SWITCH		4A0558-01	1	1	1					



**MODEL: DCM-450BWE TITLE: K. CONTROL BOX ASSEMBLY**

INDEX NO.	DESCRIPTION	MATERIAL OR MODEL NUMBER	PART NUMBER	REQUIRED NUMBER								
				G-0	G-1	H-0						
1	CONTROL BOX		2A0391G01	1	1	1						
2	COVER - CONTROL BOX		429931-01	1	1	1						
	TRUSS HEAD SCREW	4 X 8	7C31-0408	2	2	2						
3	STARTER		434172-04	1	1	1						
4	TAPPING SCREW		431415-01	6	6	6						
5	CAPACITOR		439943-05	1	1	1						
6	CAPACITOR - STARTING		3A0076-06	1	1	1						
7	STRAP		434580-12	1	1	1						
	T2 SCREW	4 X 8	7P31-0408	2	2	2						
8	TRANSFORMER	TR5267-1	2U0042-02	1	1	1						
	T2 SCREW	4 X 8	7P31-0408	2	2	2						
9	TIMER BOARD		2U0098-02	1	1	1						
10	BOARD SUPPORT		4A0336-03	6	6	6						
11	CAPACITOR		4A0894-01	1	1	1						
	T2 SCREW	4 X 8	7P31-0408	1	1	1						
12	RELAY		418271-03	1	1	1						
13	RELAY		418271-05	1	1	1						
14	RELAY		406132-03	1	1	1						
15	SWITCH BRACKET		4A1013-01	1	1	1						
	T2 SCREW	4 X 8	7P31-0408	2	2	2						
16	BUSHING		420472-03	1	1	1						
17	MICROSWITCH		4A0365-01	1	1	1						
18	SPACER		429933-01	2	2	2						
19	TAPPING SCREW		431415-02	2	2	2						
20	FUSE HOLDER		4A0892-01	1	1	1						
21	FUSE		4A0893-01	1	1	1						
22	FUSE HOLDER		4A0892-02	1	1	1						
23	FUSE		4A0893-02	1	1	1						
24	ROCKER SWITCH		4A0558-01	1	1	1						





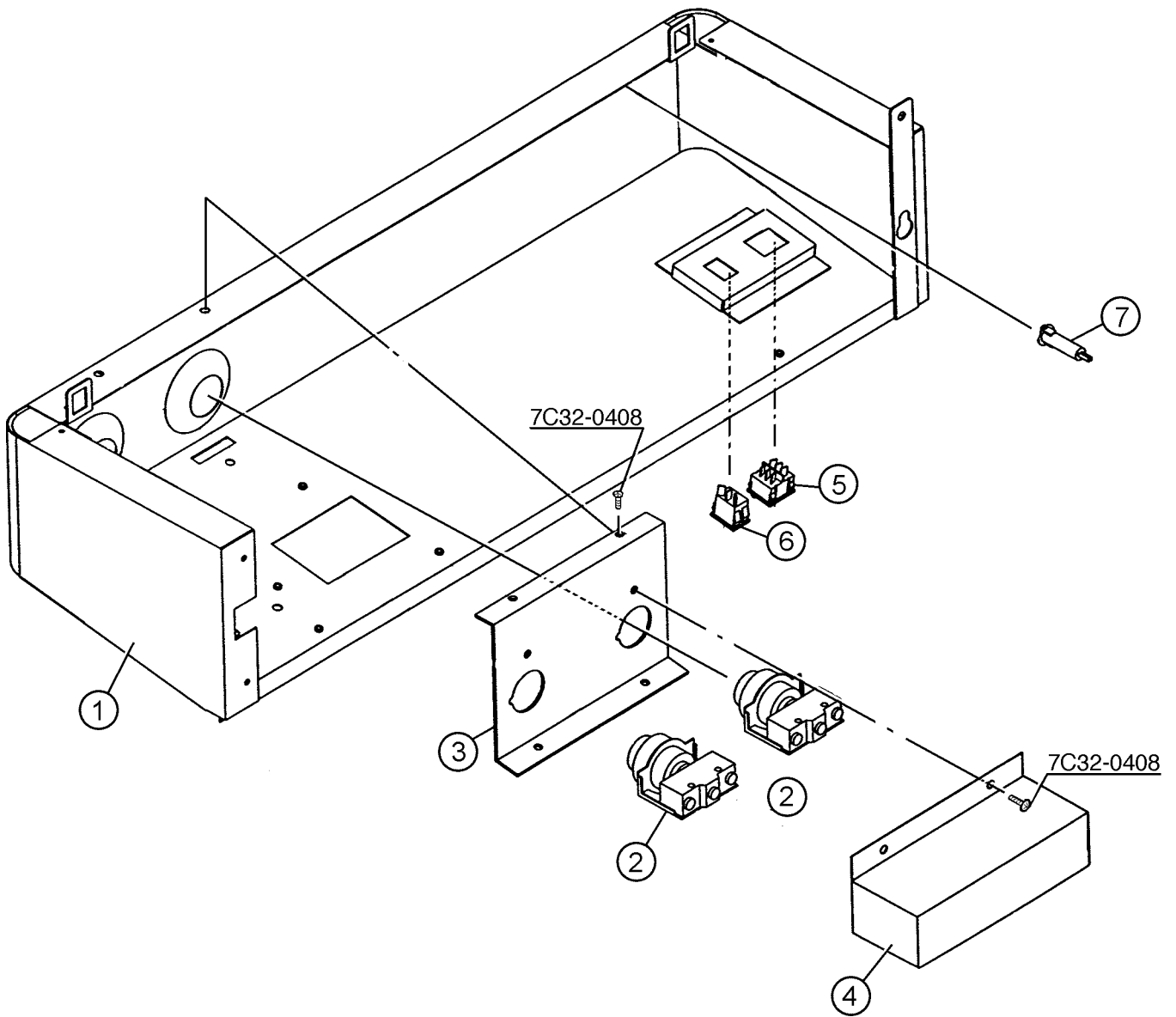



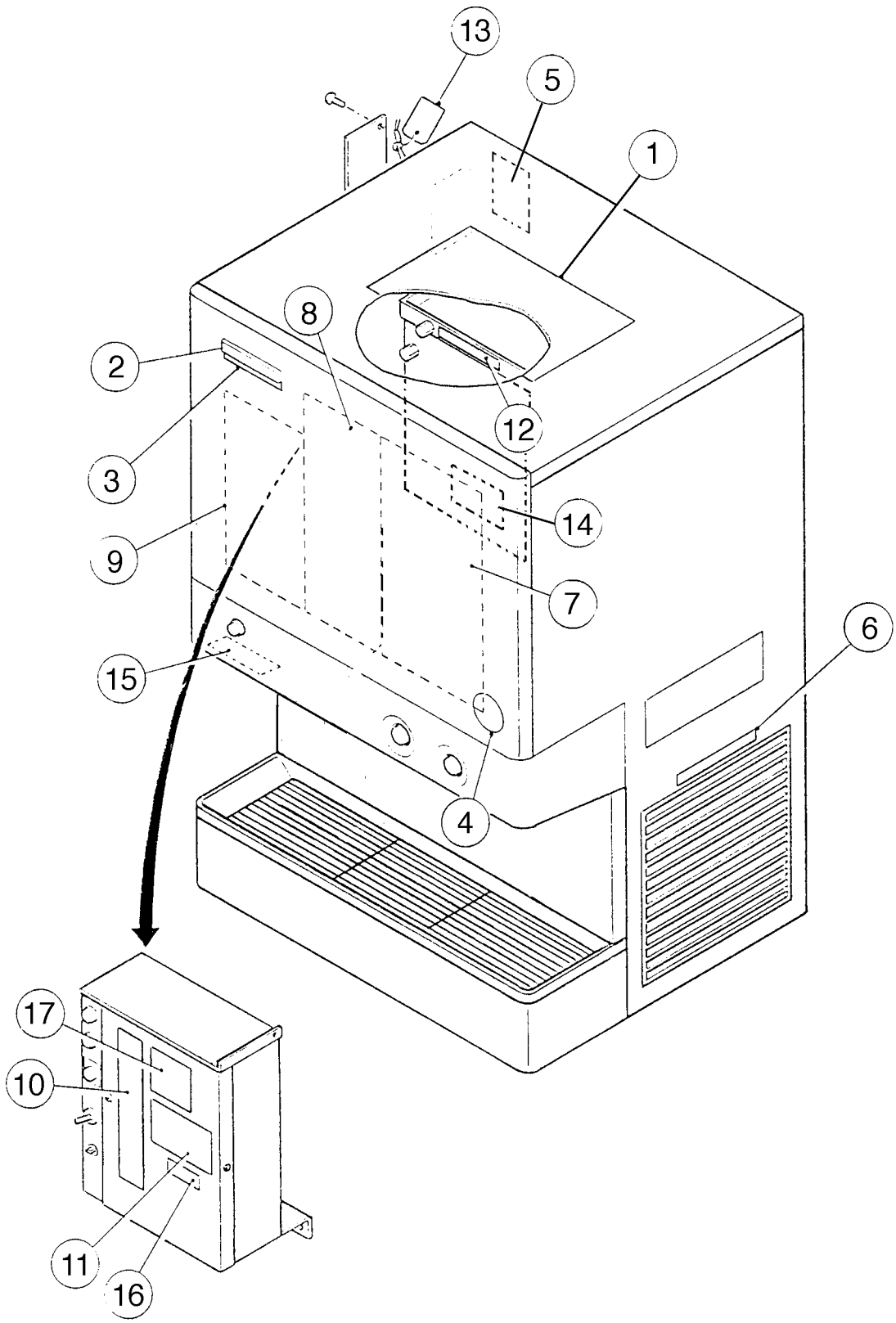

**MODEL: DCM-450BAE TITLE: M. LABEL LOCATION**

INDEX NO.	DESCRIPTION	MATERIAL OR MODEL NUMBER	PART NUMBER	REQUIRED NUMBER							
				G-0	G-1	H-0					
1	INSTRUCTION SHEET		2A0709-01	1	1	1					
2	EMBLEM		4A0560-01	1	1	1					
3	MODEL NUMBER LABEL		4A0468-13	1	1	1					
4	LABEL - PENGUIN - HA - L		4A0526-02	1	1	1					
5	NAMEPLATE		4A0609-01	2	2	1					
6	LABEL - AIR FILTER		426177-01	1	1	1					
7	INSTRUCTION LABEL		2A0711-01	1	1	1					
8	LABEL - CLEANING		2A0710-01	1	1	1					
9	WIRING LABEL		3A0656-01	1	1	1					
10	LABEL - SWITCH, FUSE		439961-01	1	1	1					
11	CAUTION LABEL (J)		439149-01	1	1	1					
12	LABEL-CAUTION: TOP PANEL		430439-01	1	1	1					
13	TAG - WARNING: ELECTRICAL CONNECTION		435005-01	1	1	1					
14	INSTRUCTION SHEET - BIN COVER		446463-01	1	1	1					
15	LABEL - SWITCH		4A1038-01	1	1	1					
16	LABEL - R22		440362-01	1	1	1					
17	RATING LABEL		4A1690-01			1					

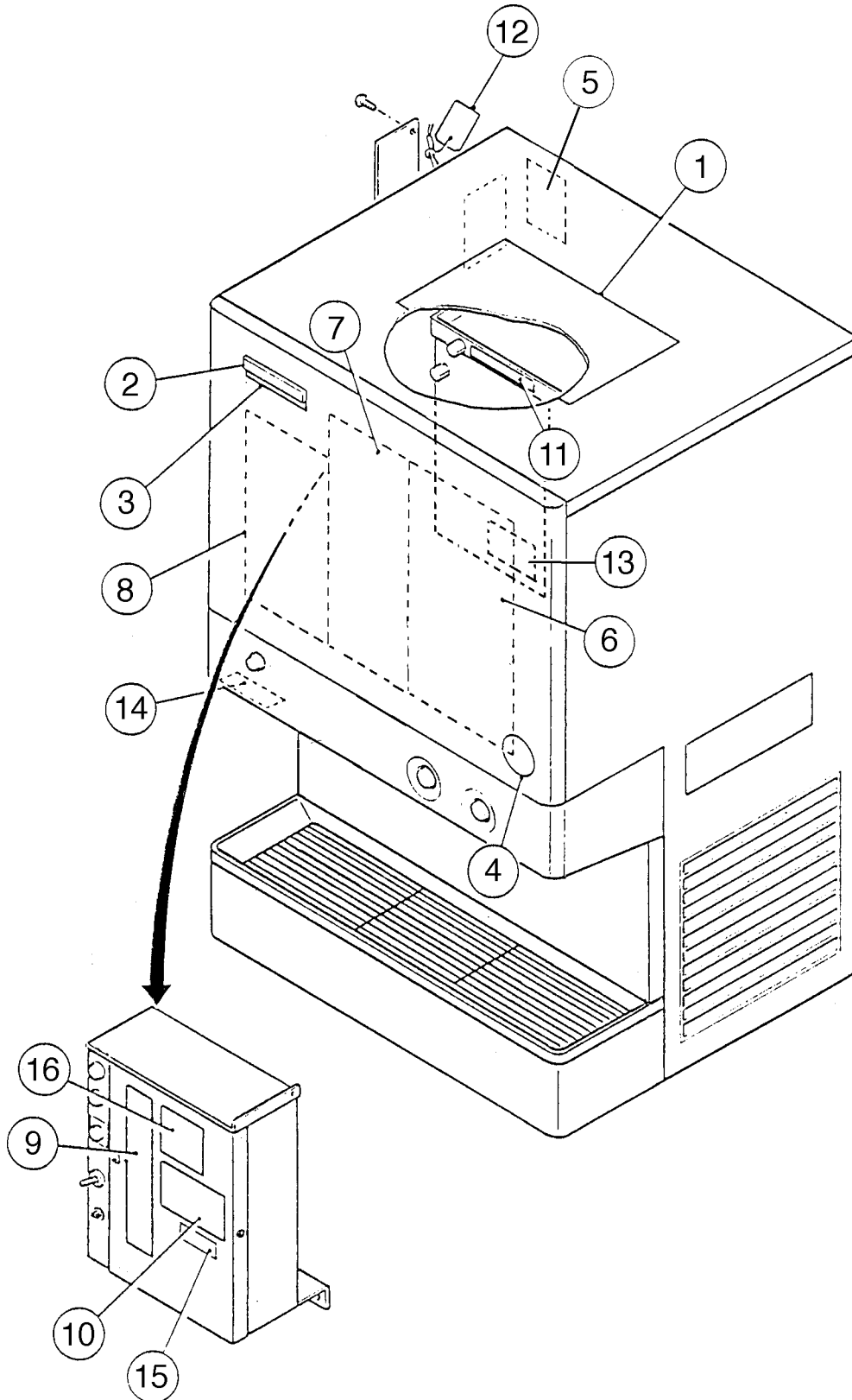

**MODEL: DCM-450BWE TITLE: M. LABEL LOCATION**

INDEX NO.	DESCRIPTION	MATERIAL OR MODEL NUMBER	PART NUMBER	REQUIRED NUMBER								
				G-0	G-1	H-0						
1	INSTRUCTION SHEET	PAPER	2A0709-01	1	1	1						
2	EMBLEM		4A0560-01	1	1	1						
3	MODEL NUMBER LABEL		4A0468-14	1	1	1						
4	LABEL - PENGUIN - HA - L		4A0526-02	1	1	1						
5	NAMEPLATE		4A0610-01	2	2	1						
6	INSTRUCTION LABEL		2A0711-01	1	1	1						
7	LABEL - CLEANING		2A0710-01	1	1	1						
8	WIRING LABEL		3A0656-01	1	1	1						
9	LABEL - SWITCH, FUSE		439961-01	1	1	1						
10	CAUTION LABEL (J)		439149-01	1	1	1						
11	LABEL-CAUTION: TOP PANEL		430439-01	1	1	1						
12	TAG - WARNING: ELECTRICAL CONNECTION		435005-01	1	1	1						
13	INSTRUCTION SHEET - BIN COVER		446463-01	1	1	1						
14	LABEL - SWITCH		4A1038-01	1	1	1						
15	LABEL- R22		440362-01	1	1	1						
16	RATING LABEL		4A1691-01			1						

