

---

NO. 71143

ISSUED: JAN. 12, 1999

REVISED: JAN. 27, 2003

---



**HOSHIZAKI  
CUBELET ICE DISPENSER**

**MODELS  
DCM-500BAF  
DCM-500BWF**

**PARTS LIST**

**DCM-500BAF**

**H-0 June, 1998  
J-0 Dec., 1998  
J-1 July, 1999  
K-0 Dec., 1999  
K-1 July, 2000  
K-2 Oct., 2000  
L-0 Dec., 2000  
L-1 Nov., 2001  
M-0 Dec., 2001  
N-0 Dec., 2002**

**DCM-500BWF**

**H-0 June, 1998  
J-0 April, 1999  
J-1 Aug., 1999  
K-0 Dec., 1999  
K-1 May, 2000  
K-2 Nov., 2000  
L-0 June, 2001  
M-0 Jan., 2002  
M-1 April, 2002  
N-0 Dec., 2002**

## MATERIAL ABBREVIATIONS

### ALUMINUM

AL = Aluminum

### COPPER

CU = Copper

### PLASTIC

ABS = Acrylonitrile -butadiene - styrene  
 AC = Polyacetal  
 EVA = Ethylene vinyl acetate  
 PA = Polyamide = Nylon  
 PC = Polycarbonate  
 PE = Polyethylene  
 PES = Polyester  
 PETP = Polyethylene terephthalate = Tetlon  
 PP = Polypropylene  
 PS = Polystyrene  
 PTFE = Polytetrafluoroethylene = Teflon  
 PUR = Polyurethane  
 PVC = Polyvinyl chloride

### RUBBER

VN = Vinyl Nitrile  
 EPDM = EP rubber  
 NBR = Nitrile butadiene rubber  
 NR = Natural rubber  
 NP = Neoprene  
 SI.R = Silicone rubber  
 SY.R = Synthetic rubber  
 EPH = Epichlorohydrin

### STEEL

G.S = Galvanized steel  
 S.S = Stainless steel  
 PS = Plated steel  
 PAS = Primed steel

## AUXILIARY CODE

Ex.1

K-0

└─── "K" is the tenth in alphabetical order with "I" skipped. So, "K" indicates "2000".

**(Note)** - = Part deleted.

x = Part deleted and replaced by "o" part (interchangeable).

Ex.2

L-0

└─── "L" is the next in alphabetical order. So, "L" indicates "2001".

o = New part for "x" in the same auxiliary code.

Ex.3

L-1

└─── Each time a part is changed non-interchangeably in a year, this number advances.

HA  
DCM-500BAF

A. ICE DISPENSER ASSEMBLY (1/2)

H-0, J-0, J-1, K-0, K-1,  
K-2, L-0, L-1, M-0, N-0

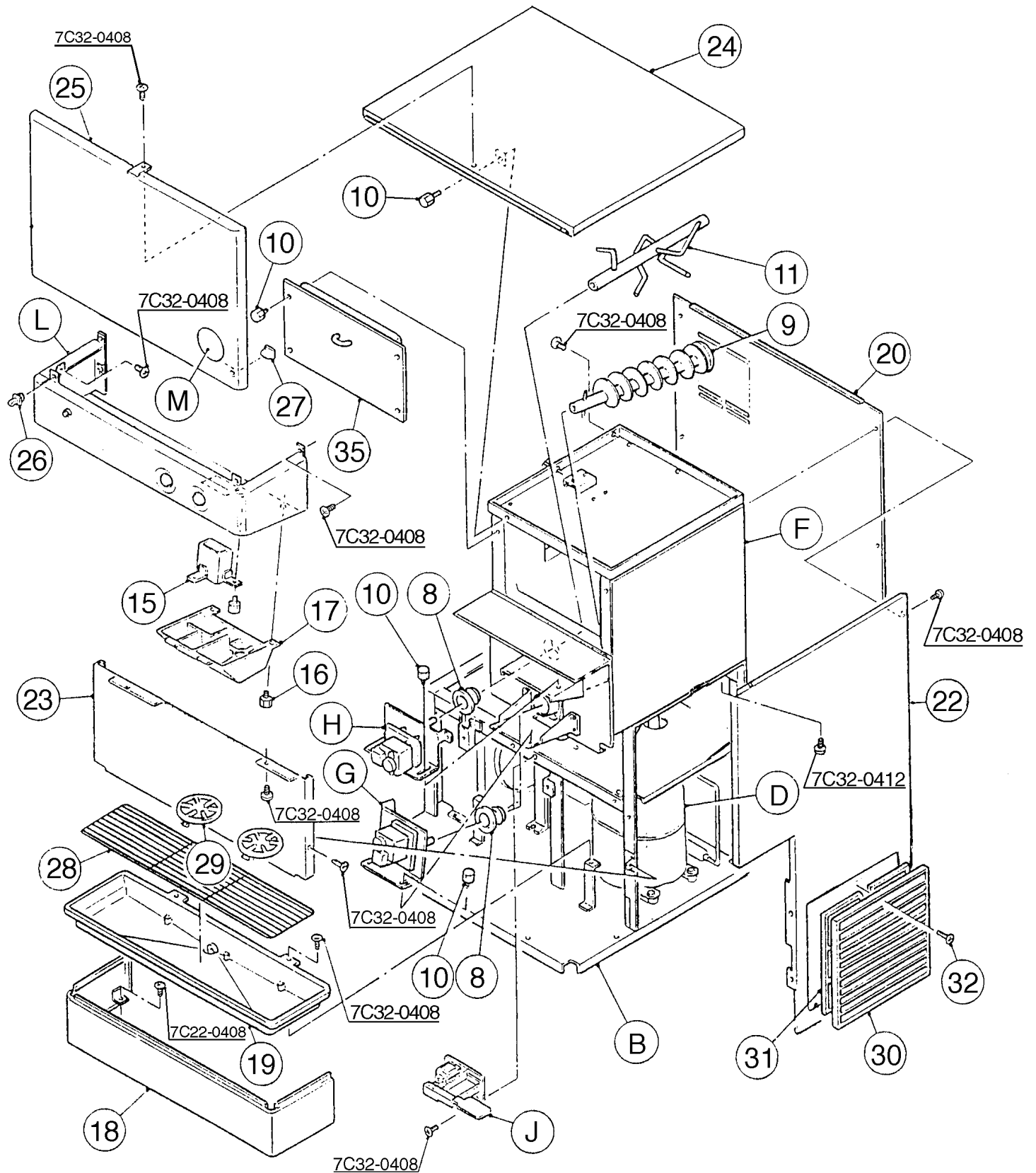

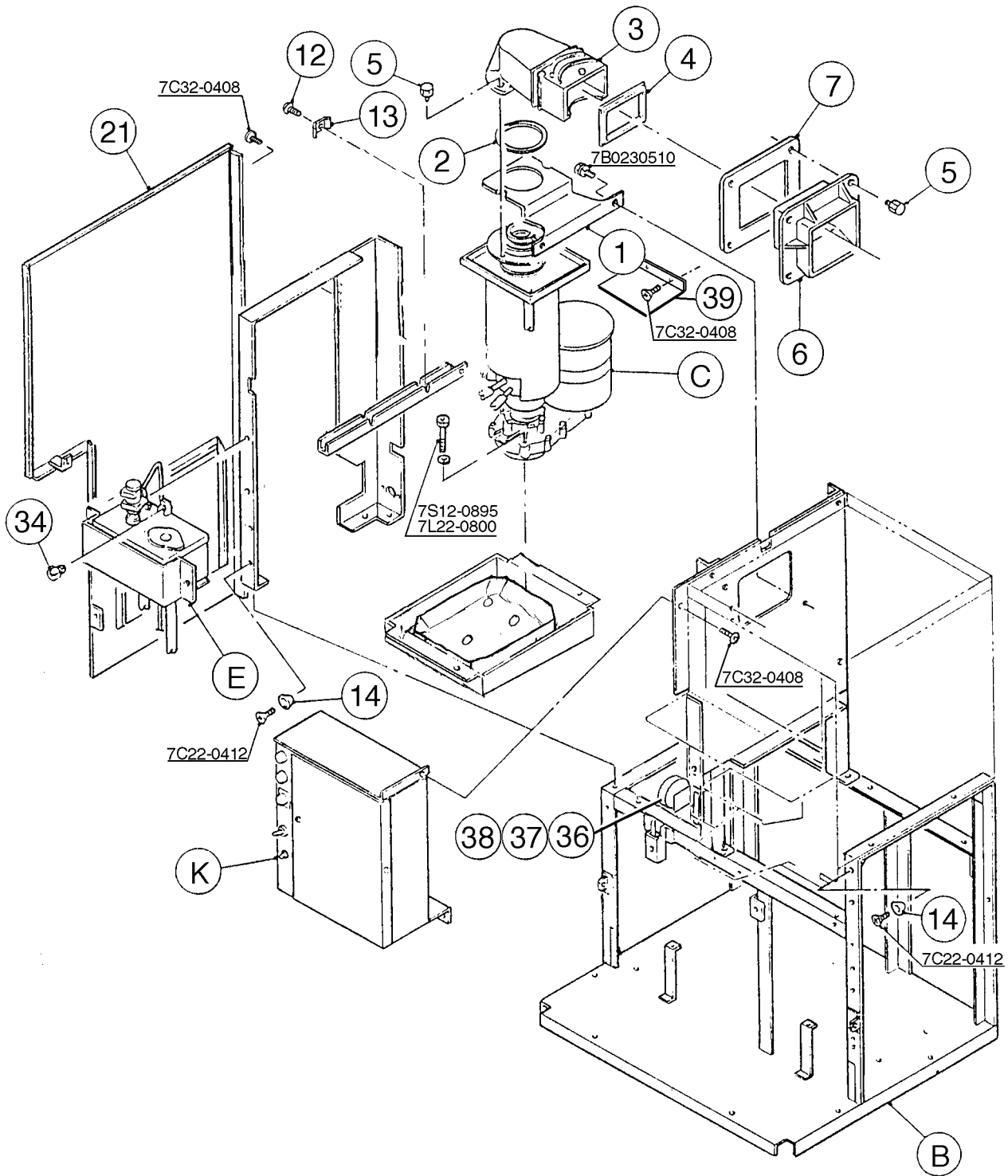

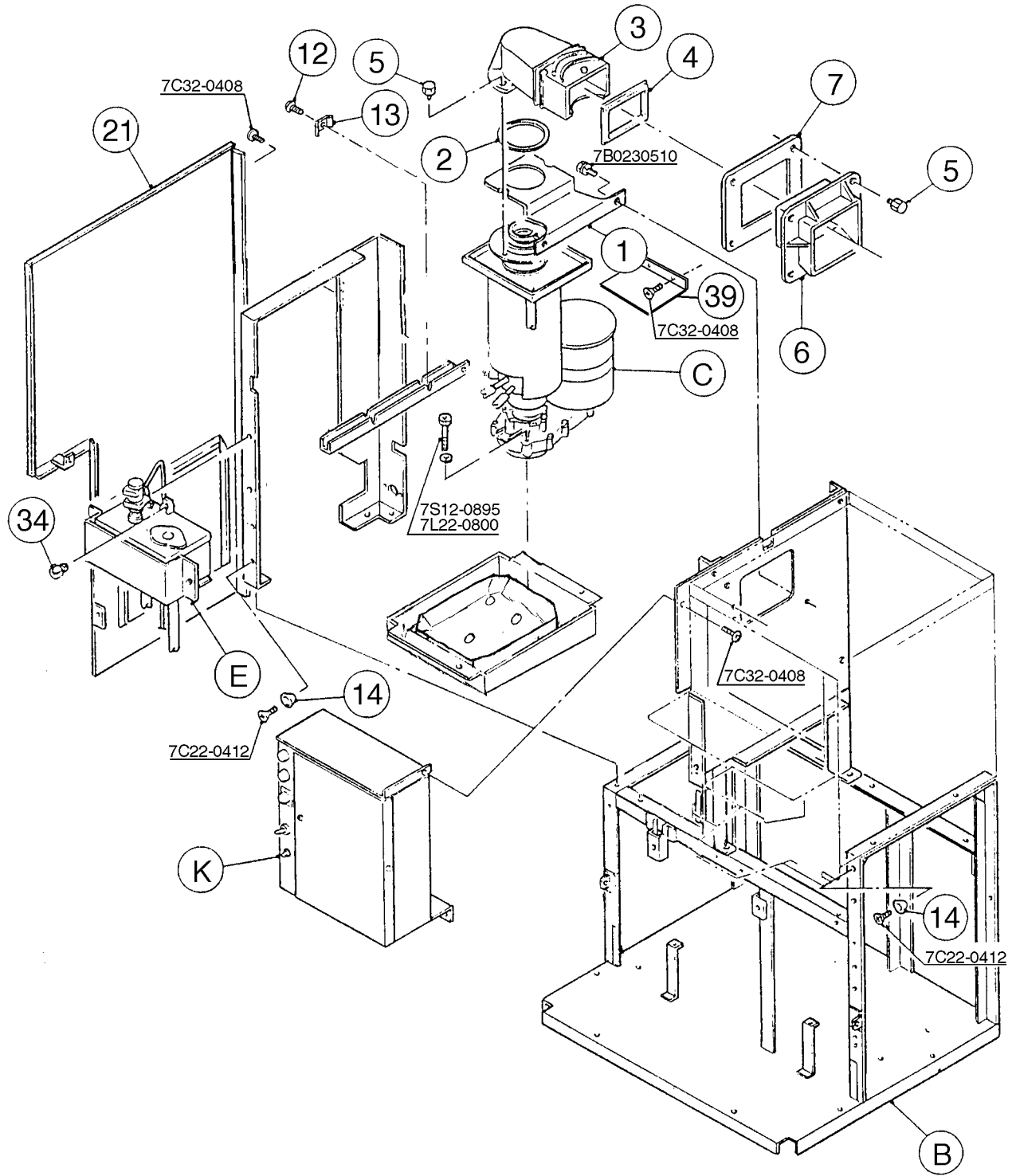

**MODEL: DCM-500BAF TITLE: A. ICE DISPENSER ASSEMBLY**

INDEX NO.	DESCRIPTION	MATERIAL OR MODEL NUMBER	PART NUMBER	REQUIRED NUMBER							
				H-0	J-0	J-1	K-0 K-1	K-2	L-0	L-1 M-0	N-0
B	FRAME ASSEMBLY	-	2A0388A05	1	1	-					
		-	2A0388A01			1	1	1	1	1	1
C	EVAPORATOR ASSEMBLY	-	3A0623A02	1	1	1	1	-			
		-	3A0623A03					1	1	1	1
	SOCKET HEAD HEX BOLT	SS, 8 X 90	7S12-0890	3	3	3	3	3	x3		
		SS, 8 X 95	7S12-0895						o3	3	3
	SPLIT LOCK WASHER	SS, 8	7L22-0800	3	3	3	3	3	3	3	3
D	REFRIGERATION CIRCUIT	-	227494A01	1	1	1	1	-			
		-	227494A02					1	1	1	1
E	WATER CIRCUIT	-	2A0395A02	1	1	1	1	1	1	1	1
F	BIN ASSEMBLY	-	2A0413A01	1	1	1	1	1	1	1	1
	TRUSS HEAD SCREW	SS, 4 X 8	7C32-0408	3	3	3	3	3	3	3	3
	TRUSS HEAD SCREW	4 X 12	7C31-0412	2	2	2	2	2	2	2	2
G	GEAR MOTOR ASSEMBLY	-	4A0622A01	1	1	1	1	1	1	1	1
H	GEAR MOTOR ASSEMBLY	-	4A0620A01	1	1	1	1	1	1	1	1
J	SHUTTER ASSEMBLY	-	2A0410A01	1	1	1	1	1	1	1	1
	TRUSS HEAD SCREW	SS, 4 X 8	7C32-0408	2	2	2	2	2	2	2	2
K	CONTROL BOX ASSEMBLY	-	227498A03	1	1	-					
		-	227498A05			1	1	1	1	1	1
	TRUSS HEAD SCREW	4 X 8	7C31-0408	3	3	3	3	3	3	3	3
L	MIDDLE FRONT PANEL ASSEMBLY	-	2A0409A03	1	1	1	1	1	1	1	1
	TRUSS HEAD SCREW	SS, 4 X 8	7C32-0408	2	2	2	2	2	2	2	2
M	LABEL LOCATION	-	2A0407A05	1	-						
		-	2A0407A07		1	-					
		-	2A0407A09			1	1	1	1	1	1
1	BRACKET - EVAPORATOR	-	3A0360-01	1	1	1	1	1	1	1	1
	HEX HEAD BOLT W/WASHER (LF)	SS, 5 X 10	7B0230510	2	2	2	2	2	2	2	2

**MODEL: DCM-500BAF TITLE: A. ICE DISPENSER ASSEMBLY**

INDEX NO.	DESCRIPTION	MATERIAL OR MODEL NUMBER	PART NUMBER	REQUIRED NUMBER							
				H-0	J-0	J-1	K-0	K-1	K-2	L-0 L-1	M-0 N-0
2	PACKING	-	427151-02	1	1	1	1	1	1	1	1
3	SPOUT	-	103329G01	1	1	1	1	1	1	1	1
4	PACKING (A) - SPOUT	-	427195-01	1	1	1	1	1	1	1	1
5	THUMBSCREW	-	415949G03	7	7	7	7	7	7	7	7
6	SPOUT (B)	-	208807-01	1	1	1	1	1	1	1	1
7	PACKING(B) - SPOUT	-	427196-01	1	1	1	1	1	1	1	1
8	GASKET	-	429758-01	2	2	2	2	2	2	2	2
9	AUGER	-	339192G01	1	1	1	1	1	1	1	1
10	THUMBSCREW	-	415949G05	11	11	11	11	11	11	11	11
11	AGITATOR	-	3A0895G01	1	1	1	1	1	1	1	1
12	SCREW - GROUNDING	-	433304-02	1	1	1	1	1	1	1	1
13	WASHER	-	433537-02	1	1	1	1	1	1	1	1
14	COLLAR	-	4H0171-01	2	2	2	2	2	2	2	2
	FLAT HEAD SCREW	SS, 4 X 12	7C22-0412	2	2	2	2	2	2	2	2
15	ICE CHUTE	-	439788G01	1	1	1	1	x1			
		-	4A2204-01					o1	1	1	1
16	THUMBSCREW	-	415949G08	4	4	4	4	4	4	4	4
17	SPOUT COVER	-	215773-01	1	1	1	1	1	1	1	1
18	PANEL (LO)	-	2A0699G01	1	1	1	1	1	1	1	1
	FT SCREW	SS, 4 X 8	7F32-0408	6	6	6	6	6	6	6	6
19	TRAY - DRIP	-	105219G01	1	1	1	1	1	1	1	x1
		-	2A2591G01								o1
	TRUSS HEAD SCREW	SS, 4 X 8	7C32-0408	4	4	4	4	4	4	4	4
20	REAR PANEL	-	2A0405-01	1	1	1	1	1	1	1	1
	TRUSS HEAD SCREW	SS, 4 X 8	7C32-0408	4	4	4	4	4	4	4	4
21	SIDE PANEL (L)	-	2A0696-01	1	1	1	1	1	1	1	1
	TRUSS HEAD SCREW	SS, 4 X 8	7C32-0408	6	6	6	6	6	6	6	6
22	SIDE PANEL (R)	-	2A0695-01	1	1	1	1	1	1	1	1
	TRUSS HEAD SCREW	SS, 4 X 8	7C32-0408	6	6	6	6	6	6	6	6



**MODEL: DCM-500BAF TITLE: A. ICE DISPENSER ASSEMBLY**

INDEX NO.	DESCRIPTION	MATERIAL OR MODEL NUMBER	PART NUMBER	REQUIRED NUMBER							
				H-0	J-0	J-1	K-0	K-1	K-2	L-0	L-1 M-0 N-0
23	APRON PANEL	-	2A0720-01	1	1	1	1	1	1	1	1
	TRUSS HEAD SCREW	SS, 4 X 8	7C32-0408	2	2	2	2	2	4	4	4
	FLAT HEAD SCREW	SS, 4 X 12	7C22-0412	2	2	2	2	2	-		
24	TOP PANEL	-	3A0640G01	1	1	1	x1				
		-	3A1728G01				o1	1	1	1	1
25	FRONT PANEL	-	3A0638G01	1	1	1	1	1	1	1	1
	TRUSS HEAD SCREW	SS, 4 X 8	7C32-0408	1	1	1	1	1	1	1	1
26	STRIKE	-	4A0515-01	2	2	2	2	2	2	2	2
27	LATCH	-	4A0508-03	2	2	2	2	2	2	2	2
28	GRILLE	-	2A0827G01	1	1	1	1	1	1	1	1
29	GUIDE - CUP	-	326702-01	2	2	2	2	2	2	2	2
30	LOUVER (B)	-	103121-03	2	2	2	2	2	2	2	2
31	AIR FILTER (B)	-	208283G03	1	1	1	1	1	1	1	1
32	TAPPING SCREW - BLACK	-	433954-01	2	2	2	2	2	2	2	2
33	-	-	-	-	-	-	-	-	-	-	-
34	BUSHING	-	420472-03	1	1	1	1	1	1	1	1
35	COVER - BIN	-	2A0880A01	1	1	1	x1				
		-	2A0880A02				o1	1	1	1	1
36	TIMER	-	4A0889-01	1	1	-					
37	CONNECTOR	-	4A0889-02	1	1	-					
38	SCREW	#6 - 32 X 3/8	4A0898-01	2	2	-					
39	MOTOR COVER	-	3A1058-01	1	1	1	1	1	1	1	1
	TRUSS HEAD SCREW	SS, 4 X 8	7C32-0408	2	2	2	2	2	2	2	2

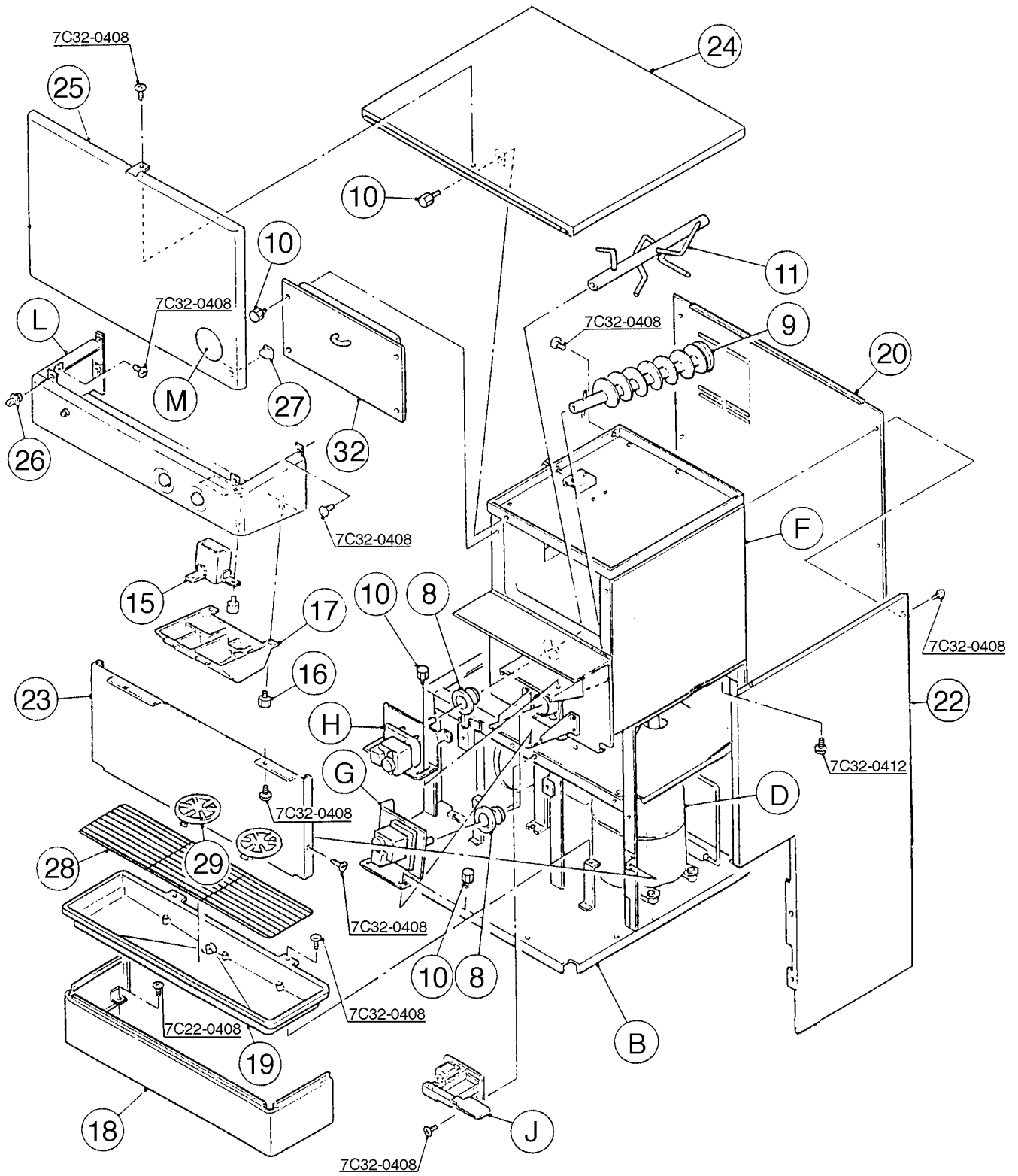



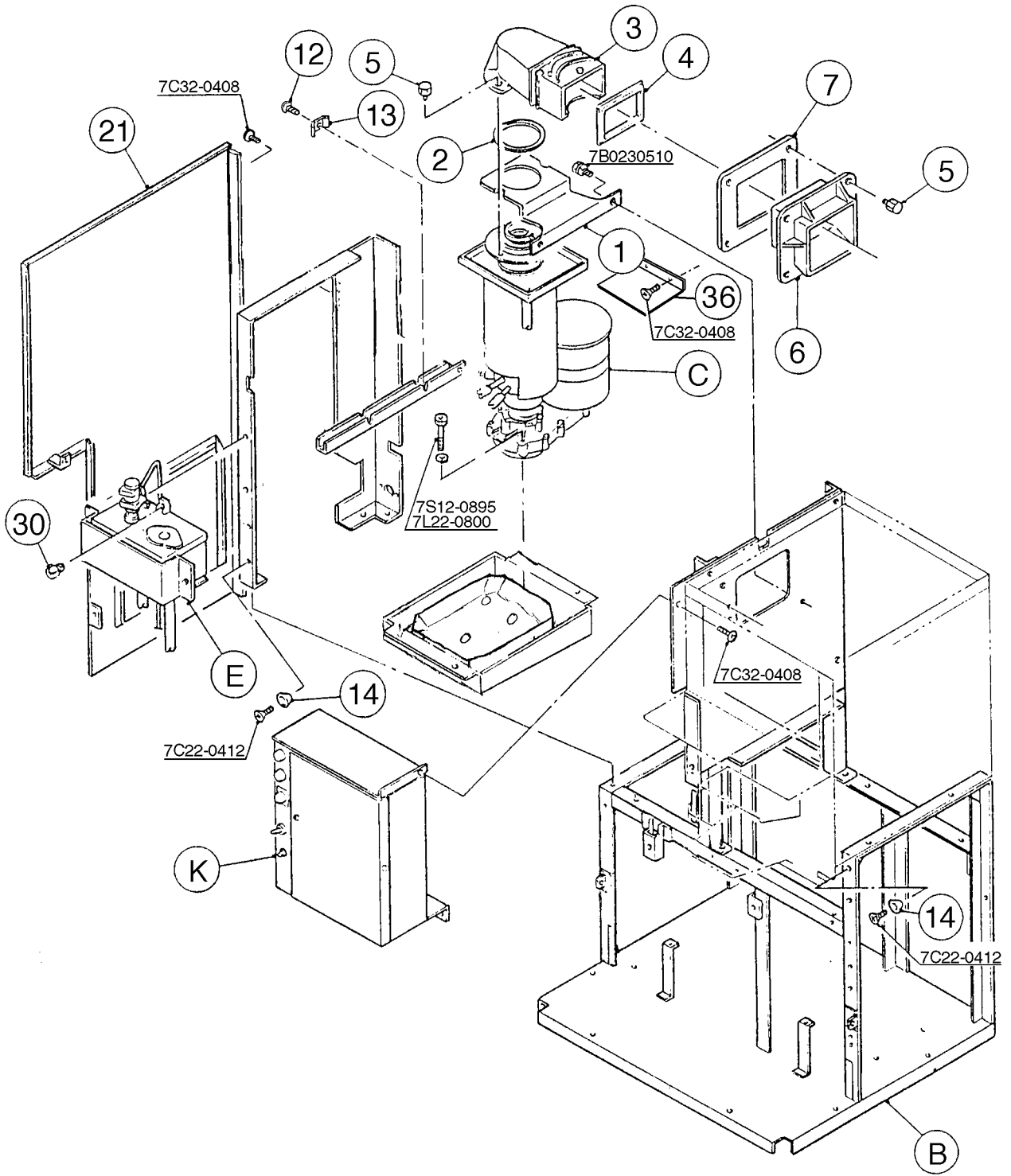

**MODEL: DCM-500BWF TITLE: A. ICE DISPENSER ASSEMBLY**

INDEX NO.	DESCRIPTION	MATERIAL OR MODEL NUMBER	PART NUMBER	REQUIRED NUMBER							
				H-0	J-0	J-1	K-0 K-1	K-1	K-2	L-0 M-0	M-1 N-0
B	FRAME ASSEMBLY	-	2A0388A05	1	1	-					
		-	2A0388A01			1	1	1	1	1	-
		-	2A0388A06								1
C	EVAPORATOR ASSEMBLY	-	3A0623A02	1	1	1	1	-			
		-	3A0623A03					1	1	1	1
	SOCKET HEAD HEX BOLT	SS, 8 X 90	7S12-0890	3	3	3	3	3	x3		
		SS, 8 X 95	7S12-0895						o3	3	3
	SPLIT LOCK WASHER	SS, 8	7L22-0800	3	3	3	3	3	3	3	3
D	REFRIGERATION CIRCUIT	-	227495A01	1	1	1	1	-			
		-	227495A02					1	1	1	-
		-	2A2399A01								1
E	WATER CIRCUIT	-	2A0395A02	1	1	1	1	1	1	1	1
F	BIN ASSEMBLY	-	2A0413A01	1	1	1	1	1	1	1	1
	TRUSS HEAD SCREW	SS, 4 X 8	7C32-0408	3	3	3	3	3	3	3	3
	TRUSS HEAD SCREW	4 X 12	7C31-0412	2	2	2	2	2	2	2	2
G	GEAR MOTOR ASSEMBLY	-	4A0622A01	1	1	1	1	1	1	1	1
H	GEAR MOTOR ASSEMBLY	-	4A0620A01	1	1	1	1	1	1	1	1
J	SHUTTER ASSEMBLY	-	2A0410A01	1	1	1	1	1	1	1	1
	TRUSS HEAD SCREW	SS, 4 X 8	7C32-0408	2	2	2	2	2	2	2	2
K	CONTROL BOX ASSEMBLY	-	227498A04	1	1	-					
		-	227498A06			1	1	1	1	1	1
	TRUSS HEAD SCREW	4 X 8	7C31-0408	3	3	3	3	3	3	3	3
L	MIDDLE FRONT PANEL ASSEMBLY	-	2A0409A03	1	1	1	1	1	1	1	1
	TRUSS HEAD SCREW	SS, 4 X 8	7C32-0408	2	2	2	2	2	2	2	2
M	LABEL LOCATION	-	2A0407A06	1	-						
		-	2A0407A08		1	-					
		-	2A0407A10			1	1	1	1	1	-
		-	2A0407A11								1

MODEL: DCM-500BWF TITLE: A. ICE DISPENSER ASSEMBLY											
INDEX NO.	DESCRIPTION	MATERIAL OR MODEL NUMBER	PART NUMBER	REQUIRED NUMBER							
				H-0	J-0	J-1	K-0 K-1	K-2	L-0	M-0	M-1 N-0
1	BRACKET - EVAPORATOR	-	3A0360-01	1	1	1	1	1	1	1	1
	HEX HEAD BOLT W/WASHER (LF)	SS, 5 X 10	7B0230510	2	2	2	2	2	2	2	2
2	PACKING	-	427151-02	1	1	1	1	1	1	1	1
3	SPOUT	-	103329G01	1	1	1	1	1	1	1	1
4	PACKING (A) - SPOUT	-	427195-01	1	1	1	1	1	1	1	1
5	THUMBSCREW	-	415949G03	7	7	7	7	7	7	7	7
6	SPOUT (B)	-	208807-01	1	1	1	1	1	1	1	1
7	PACKING(B) - SPOUT	-	427196-01	1	1	1	1	1	1	1	1
8	GASKET	-	429758-01	2	2	2	2	2	2	2	2
9	AUGER	-	339192G01	1	1	1	1	1	1	1	1
10	THUMBSCREW	-	415949G05	11	11	11	11	11	11	11	11
11	AGITATOR	-	3A0895G01	1	1	1	1	1	1	1	1
12	SCREW - GROUNDING	-	433304-02	1	1	1	1	1	1	1	1
13	WASHER	-	433537-02	1	1	1	1	1	1	1	1
14	COLLAR	-	4H0171-01	2	2	2	2	2	2	2	2
	FLAT HEAD SCREW	SS, 4 X 12	7C22-0412	2	2	2	2	2	2	2	2
15	ICE CHUTE	-	439788G01	1	1	1	x1				
		-	4A2204-01				o1	1	1	1	1
16	THUMBSCREW	-	415949G08	4	4	4	4	4	4	4	4
17	SPOUT COVER	-	215773-01	1	1	1	1	1	1	1	1
18	PANEL (LO)	-	2A0699G01	1	1	1	1	1	1	1	1
	FT SCREW	SS, 4 X 8	7F32-0408	6	6	6	6	6	6	6	6
19	TRAY - DRIP	-	105219G01	1	1	1	1	1	1	x1	
		-	2A2591G01							o1	1
	TRUSS HEAD SCREW	SS, 4 X 8	7C32-0408	4	4	4	4	4	4	4	4
20	REAR PANEL	-	2A0404-01	1	1	1	1	1	1	1	-
		-	2A2471-01								1
	TRUSS HEAD SCREW	SS, 4 X 8	7C32-0408	4	4	4	4	4	4	4	4

**MODEL: DCM-500BWF TITLE: A. ICE DISPENSER ASSEMBLY**

INDEX NO.	DESCRIPTION	MATERIAL OR MODEL NUMBER	PART NUMBER	REQUIRED NUMBER							
				H-0	J-0	J-1	K-0	K-1	K-2	L-0 M-0	M-1 N-0
21	SIDE PANEL (L)	-	2A0698-01	1	1	1	1	1	1	1	1
	TRUSS HEAD SCREW	SS, 4 X 8	7C32-0408	6	6	6	6	6	6	6	6
22	SIDE PANEL (R)	-	2A0697-01	1	1	1	1	1	1	1	1
	TRUSS HEAD SCREW	SS, 4 X 8	7C32-0408	6	6	6	6	6	6	6	6
23	APRON PANEL	-	2A0720-01	1	1	1	1	1	1	1	1
	TRUSS HEAD SCREW	SS, 4 X 8	7C32-0408	2	2	2	4	4	4	4	4
	FLAT HEAD SCREW	SS, 4 X 12	7C22-0412	2	2	2	-				
24	TOP PANEL	-	3A0640G01	1	1	1	x1				
		-	3A1728G01				o1	1	1	1	1
25	FRONT PANEL	-	3A0638G01	1	1	1	1	1	1	1	1
	TRUSS HEAD SCREW	SS, 4 X 8	7C32-0408	1	1	1	1	1	1	1	1
26	STRIKE	-	4A0515-01	2	2	2	2	2	2	2	2
27	LATCH	-	4A0508-03	2	2	2	2	2	2	2	2
28	GRILLE	-	2A0827G01	1	1	1	1	1	1	1	1
29	GUIDE - CUP	-	326702-01	2	2	2	2	2	2	2	2
30	BUSHING	-	420472-03	1	1	1	1	1	1	1	1
31	-	-	-	-	-	-	-	-	-	-	-
32	COVER – BIN	-	2A0880A01	1	1	1	x1				
		-	2A0880A02				o1	1	1	1	1
33	TIMER	-	4A0889-01	1	1	-					
34	CONNECTOR	-	4A0889-02	1	1	-					
35	SCREW	#6 - 32 X 3/8	4A0898-01	2	2	-					
36	MOTOR COVER	-	3A1058-01	1	1	1	1	1	1	1	1
	TRUSS HEAD SCREW	SS, 4 X 8	7C32-0408	2	2	2	2	2	2	2	2

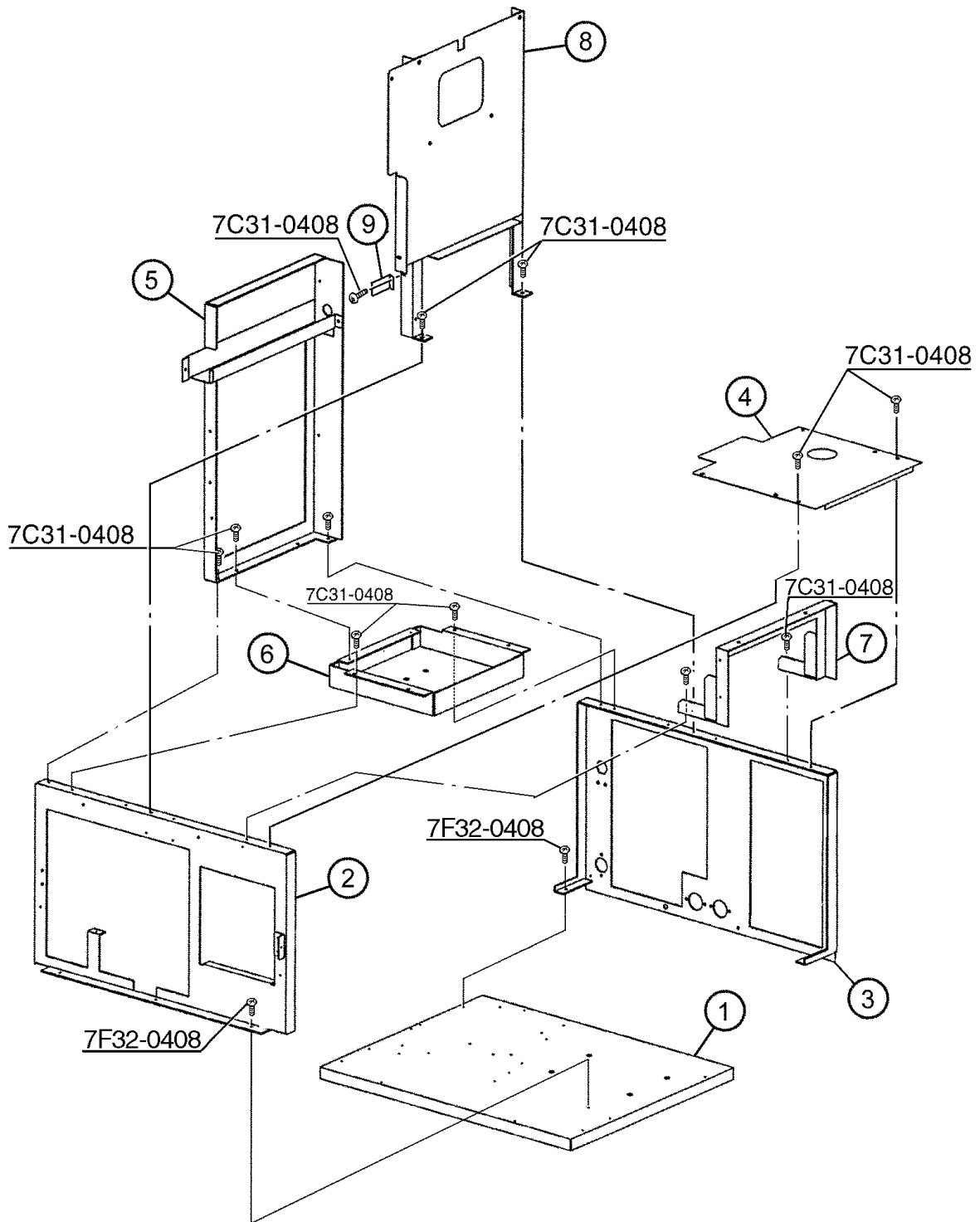



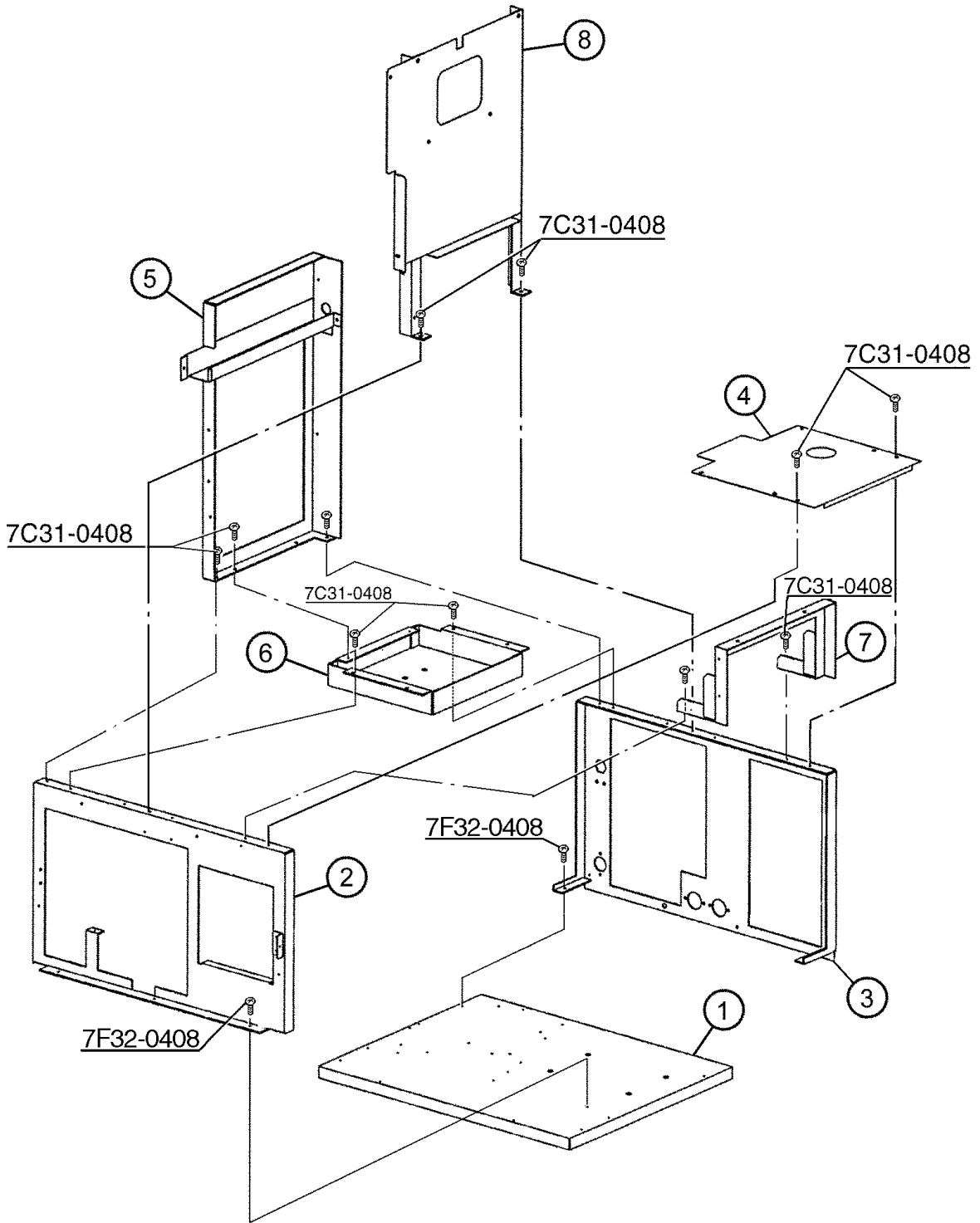

**MODEL: DCM-500BAF TITLE: B. FRAME ASSEMBLY**

INDEX NO.	DESCRIPTION	MATERIAL OR MODEL NUMBER	PART NUMBER	REQUIRED NUMBER							
				H-0	J-0	J-1	K-0 K-1 K-2	L-0 L-1	M-0 N-0		
1	BASE	-	3A0614G01	1	1	1	1	1	1		
2	FRONT FRAME	-	2A0665G01	1	1	1	1	1	1		
	FT SCREW	SS, 4 X 8	7C22-0408	3	3	3	3	3	3		
3	REAR FRAME	-	2A0666-01	1	1	1	1	1	1		
	FT SCREW	SS, 4 X 8	7C22-0408	3	3	3	3	3	3		
4	SEPARATOR	-	3A0615-01	1	1	1	1	1	1		
	TRUSS HEAD SCREW	4 X 8	7C31-0408	2	2	2	2	2	2		
5	SIDE FRAME (R)	-	3A0355G01	1	1	1	1	1	1		
	TRUSS HEAD SCREW	4 X 8	7C31-0408	4	4	4	4	4	4		
6	DRAIN PAN	-	2A0667G01	1	1	1	1	1	1		
	TRUSS HEAD SCREW	4 X 8	7C31-0408	4	4	4	4	4	4		
7	SIDE FRAME (UP)	-	3A0616G01	1	1	1	1	1	1		
	TRUSS HEAD SCREW	4 X 8	7C31-0408	4	4	4	4	4	4		
8	CENTER PANEL	-	3A0617G01	1	1	1	1	1	1		
	TRUSS HEAD SCREW	4 X 8	7C31-0408	2	2	2	2	2	2		
9	BRACKET	-	4A1598-01	1	1	-					
	TRUSS HEAD SCREW	4 X 8	7C31-0408	2	2	-					

**MODEL: DCM-500BWF TITLE: B. FRAME ASSEMBLY**

INDEX NO.	DESCRIPTION	MATERIAL OR MODEL NUMBER	PART NUMBER	REQUIRED NUMBER							
				H-0	J-0	J-1	K-0 K-1 K-2	L-0	M-0	M-1	N-0
1	BASE	-	3A0614G01	1	1	1	1	1	1	1	1
2	FRONT FRAME	-	2A0665G01	1	1	1	1	1	1	1	1
	FT SCREW	SS, 4 X 8	7C22-0408	3	3	3	3	3	3	1	1
3	REAR FRAME	-	2A0666-01	1	1	1	1	1	1	-	
		-	2A2472-01							1	1
	FT SCREW	SS, 4 X 8	7C22-0408	3	3	3	3	3	3	3	3
4	SEPARATOR	-	3A0615-01	1	1	1	1	1	1	1	1
	TRUSS HEAD SCREW	4 X 8	7C31-0408	2	2	2	2	2	2	2	2
5	SIDE FRAME (R)	-	3A0355G01	1	1	1	1	1	1	1	1
	TRUSS HEAD SCREW	4 X 8	7C31-0408	4	4	4	4	4	4	4	4
6	DRAIN PAN	-	2A0667G01	1	1	1	1	1	1	1	1
	TRUSS HEAD SCREW	4 X 8	7C31-0408	4	4	4	4	4	4	4	4
7	SIDE FRAME (UP)	-	3A0616G01	1	1	1	1	1	1	1	1
	TRUSS HEAD SCREW	4 X 8	7C31-0408	4	4	4	4	4	4	4	4
8	CENTER PANEL	-	3A0617G01	1	1	1	1	1	1	1	1
	TRUSS HEAD SCREW	4 X 8	7C31-0408	2	2	2	2	2	2	2	2
9	BRACKET	-	4A1598-01	1	1	-					
	TRUSS HEAD SCREW	4 X 8	7C31-0408	2	2	-					

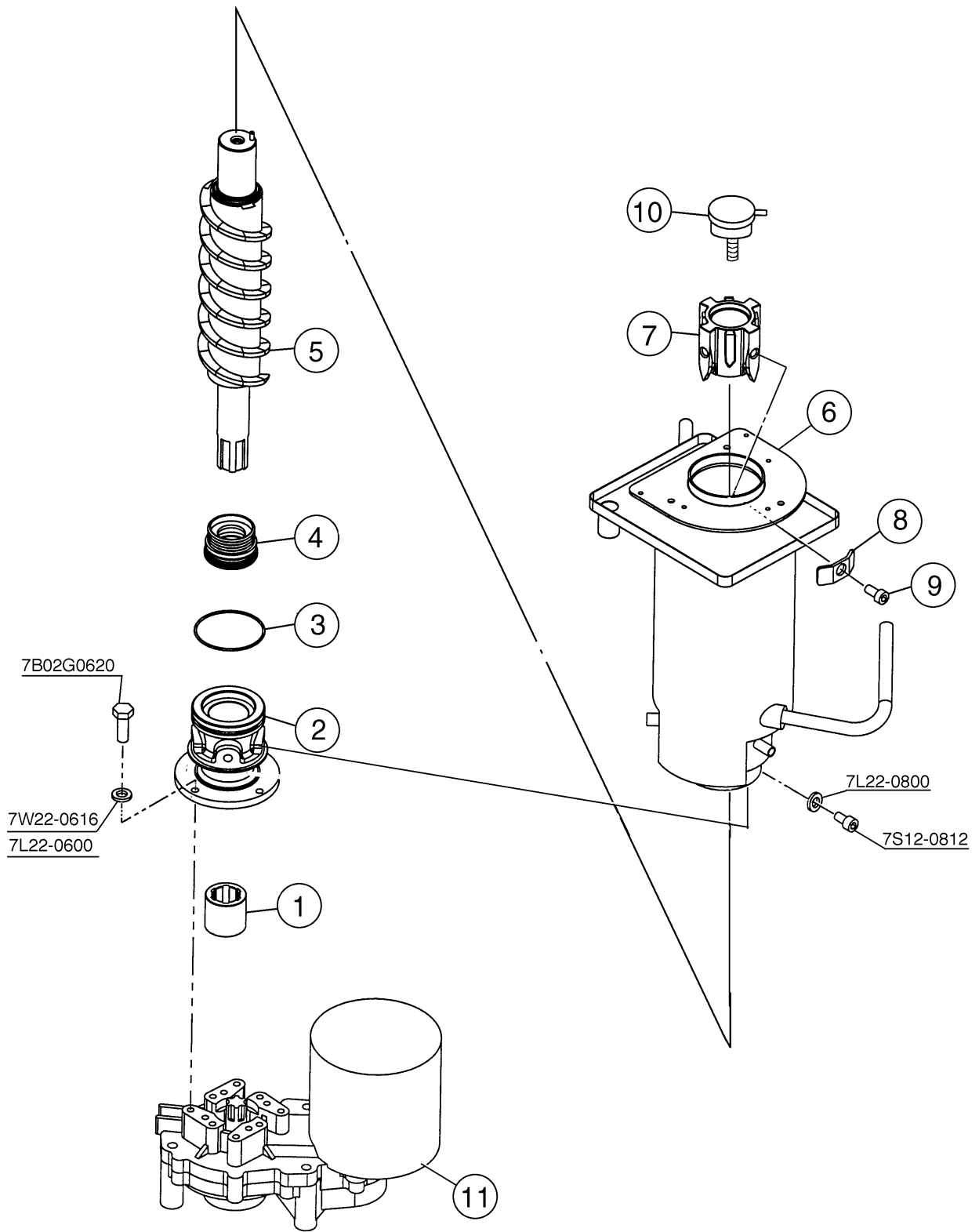

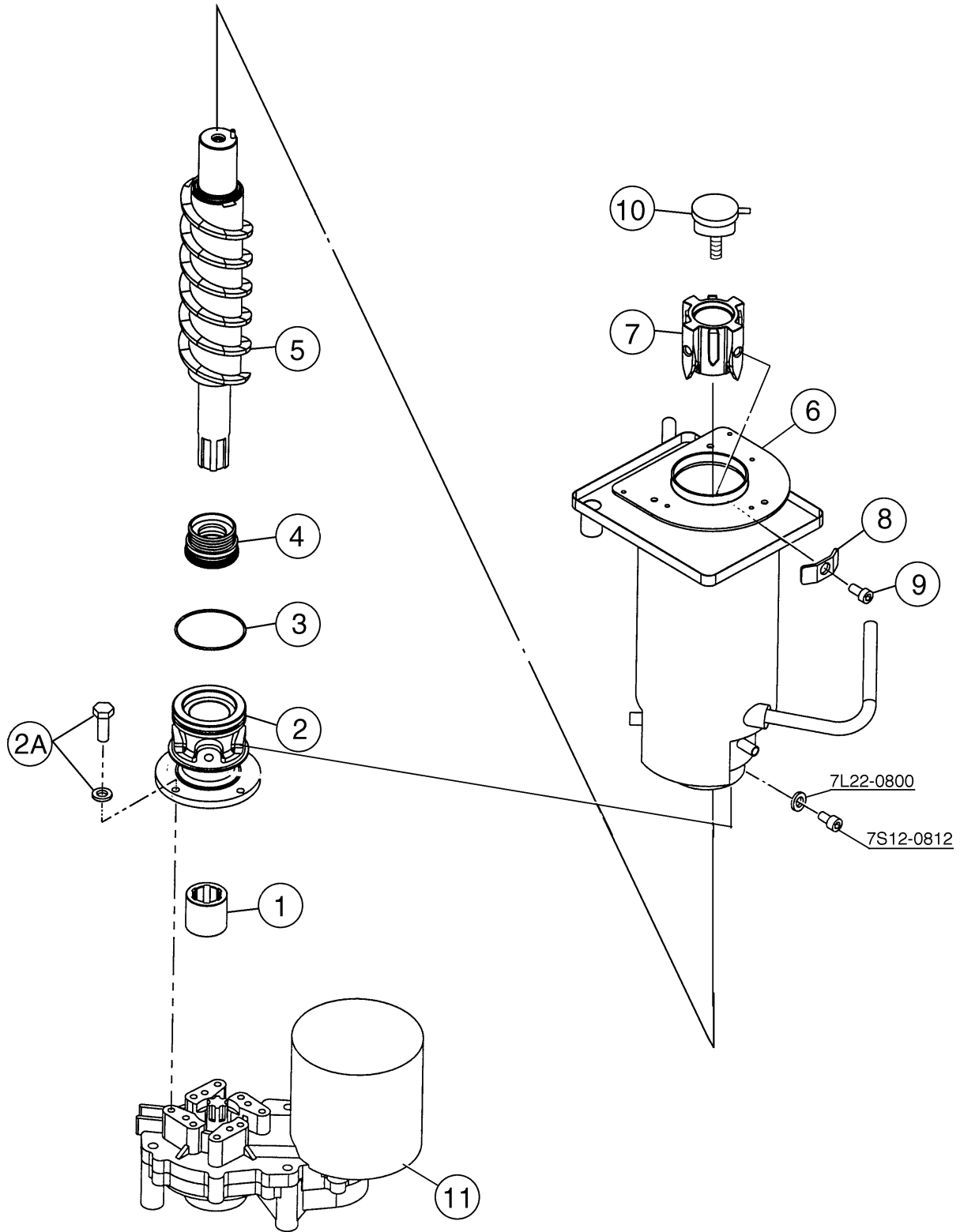

**MODEL: DCM-500BAF, BWF TITLE: C. EVAPORATOR ASSEMBLY**

INDEX NO.	DESCRIPTION	MATERIAL OR MODEL NUMBER	PART NUMBER	REQUIRED NUMBER							
				H-0	J-0	J-1	K-0 K-1	K-2	L-0	L-1	M-0 M-1 N-0
1	COUPLING – SPLINE	-	4A1297-01	1	1	1	1	1	1	1	1
2	HOUSING	-	2A0947G01	1	1	1	1	1	1	1	1
	HEX BOLT (GOLD STAINLESS)	6 X 20	7B02G0620	4	4	4	4	4	4	x4	
	PLAIN WASHER	-	7W22-0616	4	4	4	4	4	4	x4	
	SPLIT LOCK WASHER	SS, 6	7L22-0600	4	4	4	4	4	4	x4	
2A	BOLT	-	458660-01							o4	4
3	“O” RING	G65	7616-G065	2	2	2	2	2	2	2	2
4	MECHANICAL SEAL	HK9A-MN DIAM 30	432492-01	1	1	1	1	1	1	1	1
5	AUGER	-	2A0960G02	1	1	1	1	1	1	x1	
		-	2A0932G02							o1	1
6	EVAPORATOR	-	319154G02	1	1	1	1	-			
		-	2A1733G01					1	1	1	1
	SOCKET HEAD CAP SCREW	SS, 8 X12	7S12-0812	4	4	4	4	4	4	4	4
	SPLIT LOCK WASHER	8	7L22-0800	4	4	4	4	4	4	4	4
7	EXTRUDING HEAD – 70C	-	216530G01	1	1	1	1	1	1	x1	
		-	216530G04							o1	1
8	WASHER	-	427184-01	4	4	4	4	4	4	4	4
9	SOCKET HEAD CAP SCREW	SS, 8 X 14	429121-01	4	4	4	4	4	4	4	4
10	CUTTER	-	427183G01	1	1	1	1	1	1	1	1
11	GEAR MOTOR	-	4A1296-01	1	1	1	1	x1			
		-	4A2194-01					o1	1	1	1

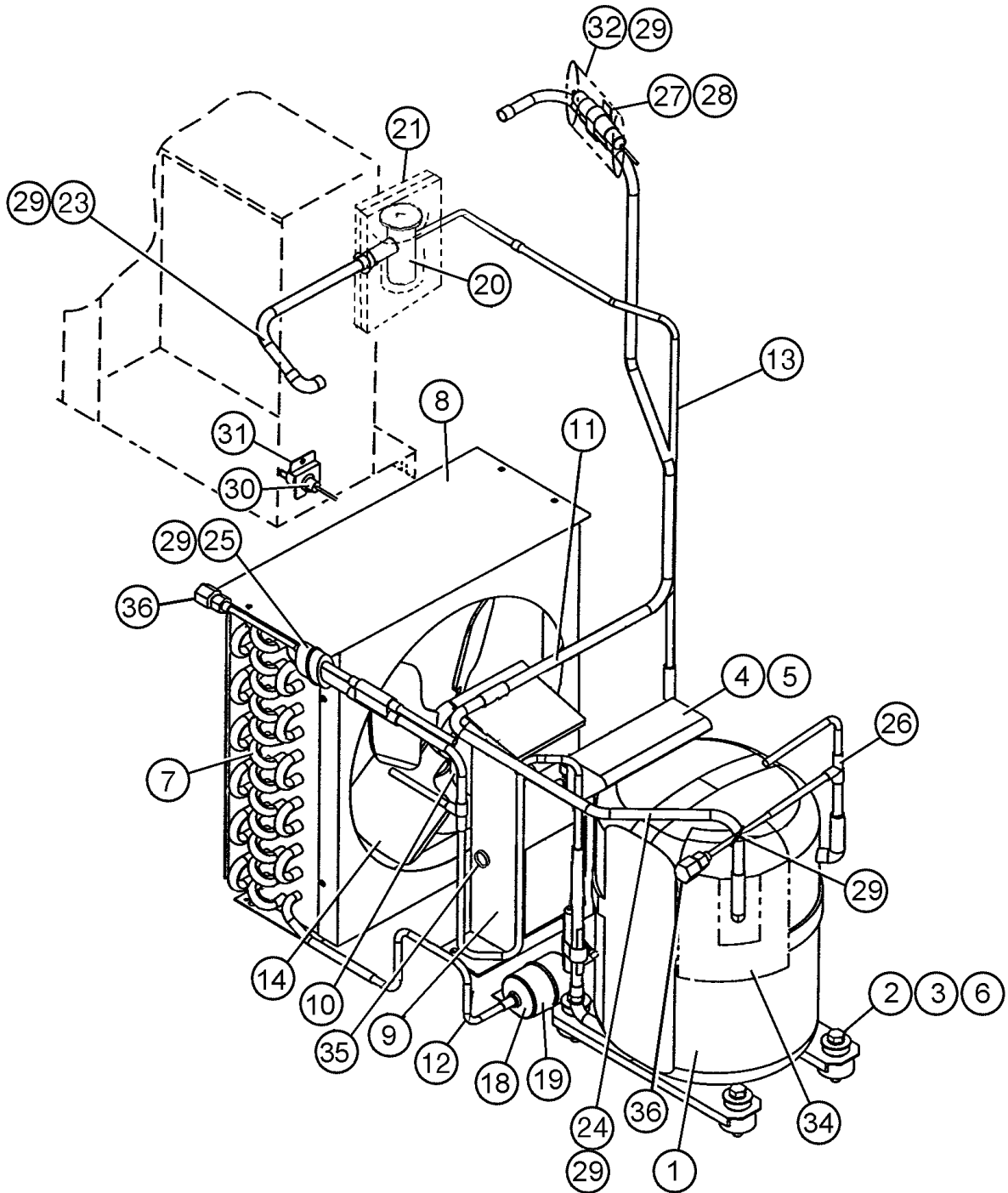

**MODEL: DCM-500BAF TITLE: D. REFRIGERATION CIRCUIT**

INDEX NO.	DESCRIPTION	MATERIAL OR MODEL NUMBER	PART NUMBER	REQUIRED NUMBER								
				H-0	J-0	J-1	K-0	K-1	K-2	L-0 L-1	M-0 N-0	
1	COMPRESSOR	-	4A2300-01	1	1	1	1	1	1	1	1	1
2	GROMMET	-	434403-01	4	4	4	4	4	4	4	4	4
3	SPACER	-	434404-01	4	4	4	4	4	4	4	4	4
4	PROTECTOR	-	4A1805-01	1	1	1	1	1	1	1	1	1
5	PROTECTOR HOLDER	-	437339-01	1	1	1	1	1	1	1	1	1
6	BOLT	-	437889-01	4	4	4	4	4	4	4	4	4
7	CONDENSER	-	210104-02	1	1	1	1	1	1	1	1	1
	FT SCREW	SS, 4 X 8	7F32-0408	2	2	2	2	2	2	2	2	2
8	SHROUD		2A0728-01	1	1	1	1	1	1	1	1	1
	T2 SCREW	4 X 8	7P31-0408	6	6	6	6	6	6	6	6	6
9	FAN MOTOR BRACKET	-	3A0650-01	1	1	1	1	1	1	1	1	1
10	FAN MOTOR	-	440911-01	1	1	1	1	1	1	1	1	1
	HEX HEAD BOLT W/WASHER (LF)	SS, 5 X 12	7B0230512	4	4	4	4	4	4	4	4	4
	SELF-LOCKING NUT	No. 8-32	7N21I0832	4	4	4	4	4	4	4	4	4
11	COPPER TUBE	COPPER	340127G01	1	1	1	1	1	1	1	1	1
12	COPPER TUBE	COPPER	453831-01	1	1	1	1	1	1	1	1	1
13	COPPER TUBE	COPPER	340129-01	1	1	1	1	1	1	1	1	1
14	FAN BLADE	-	444898-01	1	1	1	1	1	1	1	1	1
15	-		-									
16	-		-									
17	-		-									
18	DRIER	-	4A1113-01	1	1	1	1	1	1	1	1	1
19	DRIER BRACKET	-	445847-01	1	1	1	1	1	1	1	1	1
	FT SCREW	SS, 4 X 8	7F32-0408	1	1	1	1	1	1	1	1	1
20	EXPANSION VALVE	-	4A1117-01	1	1	1	1	1	1	1	1	1
21	EXP. VALVE COVER	-	4A1168-01	1	1	1	1	1	1	1	1	1



**MODEL: DCM-500BAF TITLE: D. REFRIGERATION CIRCUIT**

INDEX NO.	DESCRIPTION	MATERIAL OR MODEL NUMBER	PART NUMBER	REQUIRED NUMBER								
				H-0	J-0	J-1	K-0	K-1	K-2	L-0 L-1	M-0 N-0	
22	-		-									
23	COPPER TUBE	COPPER	453829G01	1	1	1	1	1	-			
	COPPER TUBE (B) LOW-SIDE	COPPER	4A2175G01						1	1	1	
24	COPPER TUBE	COPPER	227500G01	1	1	1	1	1	-			
	COPPER TUBE (A) HIGH-SIDE	COPPER	2A1821G01						1	1	1	
25	INSULATION TUBE	L=30	7762-0717	2	2	2	2	2	2	2	2	2
26	COPPER TUBE - ACCESS VALVE	COPPER	453830G01	1	1	1	1	1	1	1	1	1
27	CLAMP	-	443461-01	2	2	2	2	2	2	2	2	2
28	HOLDER/EXP. VALVE - 3/8	-	3A0107-01	2	2	2	2	2	2	2	2	2
29	TIE	CV-150	7920-0003	11	11	11	11	11	11	11	11	11
30	PRESSURE SWITCH	-	433441-07	1	1	1	1	1	1	1	1	1
31	PRESSURE SWITCH BRCKT.	-	434938-01	1	1	1	1	1	1	1	1	1
	T2 SCREW	4 X 8	7P31-0408	1	1	1	1	1	1	1	1	1
32	INSULATION TUBE	L=150	7762-2646	1	1	1	1	1	1	1	1	1
33	-	-	-									
34	INSULATION SHEET	-	4A0366-01	1	1	1	1	1	1	1	1	1
35	BUSHING	SB-562-7	420470-09		1	1	1	1	1	1	1	1
36	ACCESS VALVE	-	457729-01	2	2	2	2	2	2	2	2	2

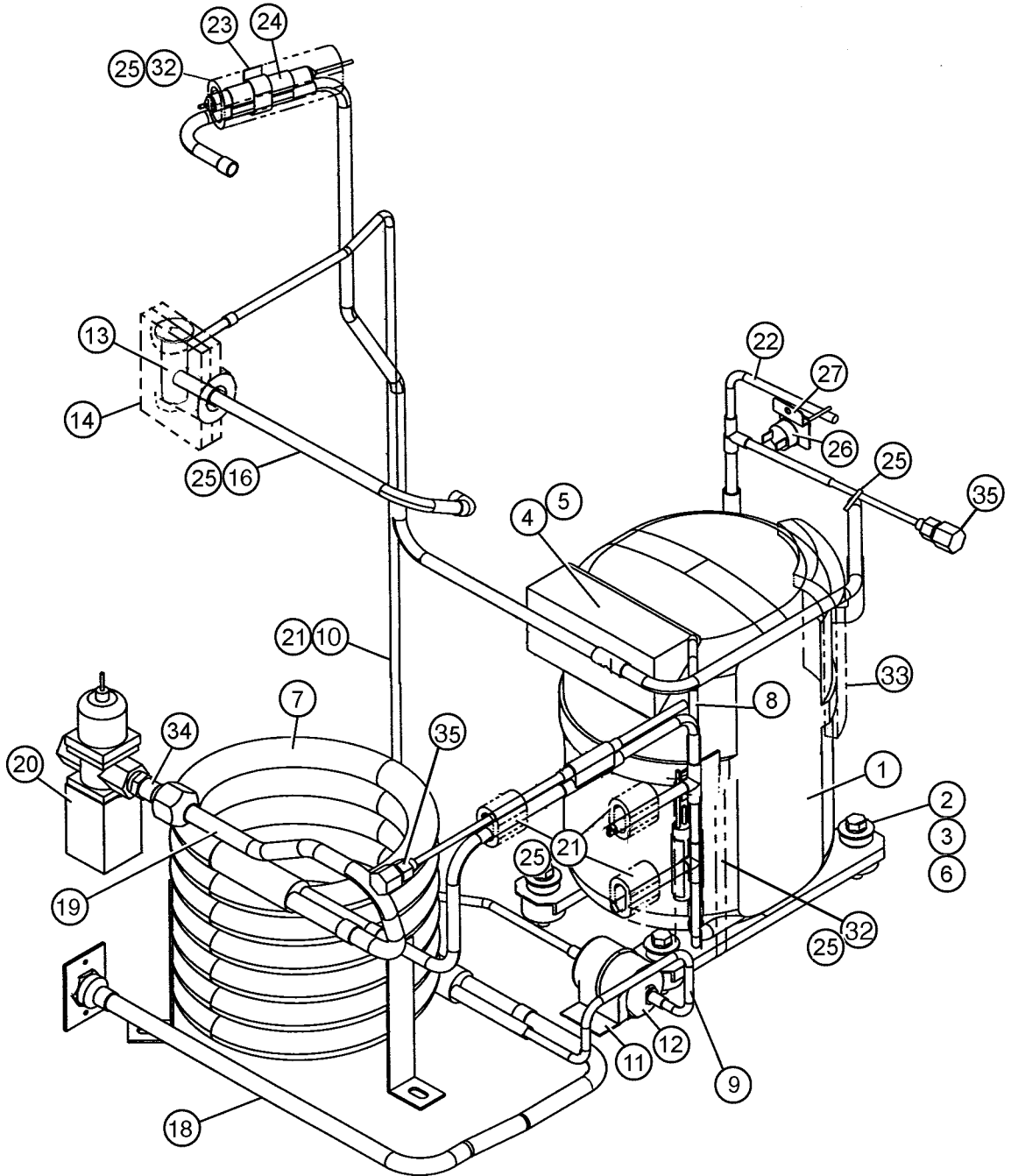

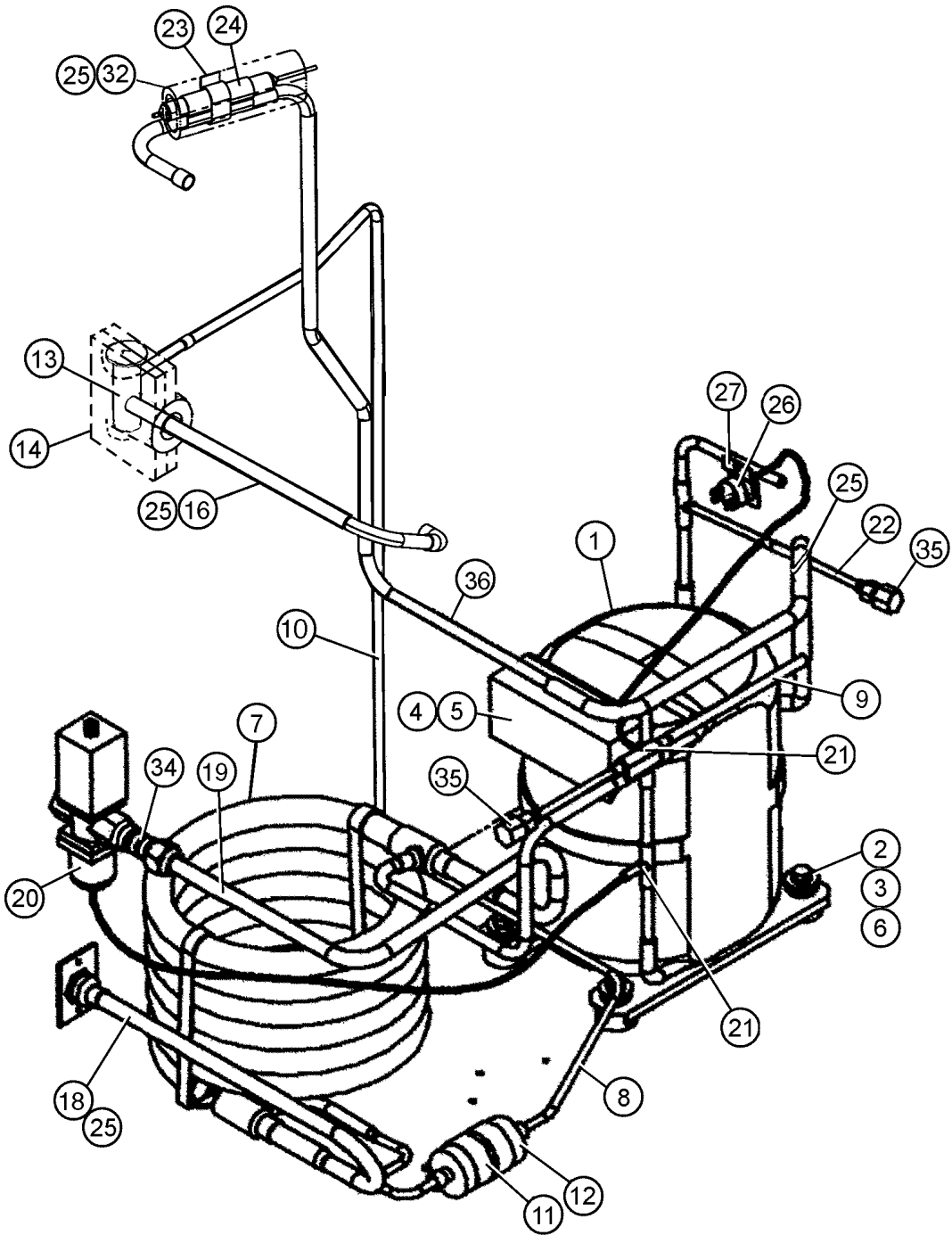

**MODEL: DCM-500BWF TITLE: D. REFRIGERATION CIRCUIT**

INDEX NO.	DESCRIPTION	MATERIAL OR MODEL NUMBER	PART NUMBER	REQUIRED NUMBER							
				H-0	J-0 J-1	K-0	K-1	K-2	L-0	M-0	M-1 N-0
1	COMPRESSOR	-	4A1272-01	1	1	1	1	1	x1		
		-	4A2300-01						o1	1	1
2	GROMMET	-	434403-01	4	4	4	4	4	4	4	4
3	SPACER	-	434404-01	4	4	4	4	4	4	4	4
4	PROTECTOR	-	4A1805-01	1	1	1	1	1	1	1	1
5	PROTECTOR HOLDER	-	437339-01	1	1	1	1	1	1	1	1
6	BOLT	-	437889-01	4	4	4	4	4	4	4	4
7	CONDENSER - WATER COOLED	-	212929-03	1	1	x1					
		-	212929-04			o1	1	1	1	1	-
		-	2A2359G02								1
	FT SCREW	SS, 4 X 8	7F32-0408	3	3	3	3	3	3	3	-
	HEX HEAD BOLTWASHER	SS, 5X12	7B02-0512								2
	WASHER	SS, M5	7W22-0500								2
8	COPPER TUBE	-	340128G01	1	1	1	1	1	1	1	-
	COPPER TUBE (B) HI-SIDE	-	4A2680-01								1
9	COPPER TUBE	-	453832-01	1	1	1	1	1	1	1	-
	COPPER TUBE (A) HI-SIDE	-	3A2215G01								1
10	HEAT EXCHANGER	-	227499G01	1	1	1	1	-			
		-	2A1822G01					1	1	1	-
	COPPER TUBE (C) HI-SIDE	-	2A2455-01								1
11	DRIER BRACKET	-	445847-01	1	1	1	1	1	1	1	1
12	DRIER	-	4A1113-01	1	1	1	1	1	1	1	1
	FT SCREW	SS, 4 X 8	7F32-0408	1	1	1	1	1	1	1	1
13	EXPANSION VALVE	-	4A1117-01	1	1	1	1	1	1	1	1
14	EXP. VALVE COVER	-	4A1168-01	1	1	1	1	1	1	1	1
15	-	-	-								
16	COPPER TUBE	-	453829G01	1	1	1	1	-			
	COPPER TUBE (B) L0-SIDE	-	4A2175G01					1	1	1	1

**MODEL: DCM-500BWF TITLE: D. REFRIGERATION CIRCUIT**

INDEX NO.	DESCRIPTION	MATERIAL OR MODEL NUMBER	PART NUMBER	REQUIRED NUMBER								
				H-0	J-0 J-1	K-0	K-1	K-2	L-0	M-0	M-1 N-0	
17	-	-	-									
18	WATER TUBE	-	3A0652G01	1	1	1	1	1	1	1	-	
	WATER TUBE INLET	-	3A2230G01									1
19	WATER TUBE	-	3A0653G01	1	1	1	1	1	1	1	x1	
	WATER TUBE OUTLET	-	3A2231G01									o1
20	WATER REGULATOR	-	4A0911-04	1	1	1	1	1	1	1	1	1
	TRUSS HEAD SCREW	4 X 6	7C31-0406	2	2	2	2	2	2	2	2	2
21	INSULATION TUBE	L=30	7762-0717	3	3	3	3	3	3	3	3	2
22	COPPER TUBE - ACCESS VALVE	-	453830G01	1	1	1	1	1	1	1	1	1
23	CLAMP	-	443461-01	2	2	2	2	2	2	2	2	1
24	HOLDER/EXP. VALVE - 3/8	-	3A0107-01	2	2	2	2	2	2	2	2	2
25	CABLE TIE	CV-150	7920-0003	16	16	16	16	16	16	16	16	15
26	PRESSURE SWITCH	-	433441-05	1	1	1	1	1	1	1	1	1
27	PRESS. SWITCH BRACKET	-	434938-01	1	1	1	1	1	1	1	1	1
	T2 SCREW	4 X 8	7P31-0408	1	1	1	1	1	1	1	1	1
28	-		-									
29	-		-									
30	-		-									
31	-		-									
32	INSULATION TUBE	L=150	7762-2646	2	2	2	2	2	2	2	2	2
33	INSULATION SHEET	-	4A0366-01	1	1	1	1	1	1	1	1	-
34	MALE CONNECTOR	-	4A1087-01	1	1	1	1	1	1	1	1	1
35	ACCESS VALVE	-	457729-01	2	2	2	2	2	3	2	2	2
36	COPPER TUBE (A) LO-SIDE	-	2A1821G01									1

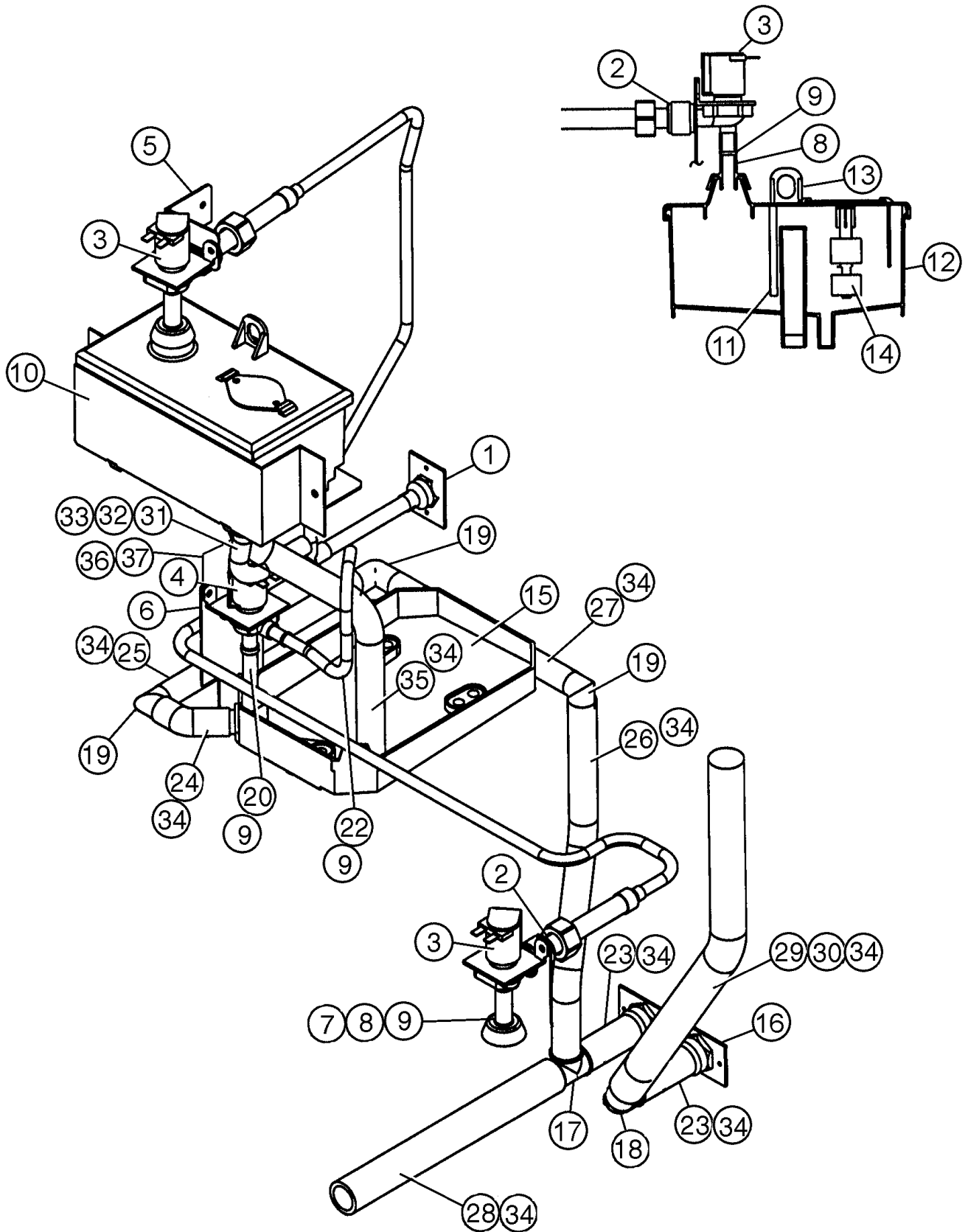



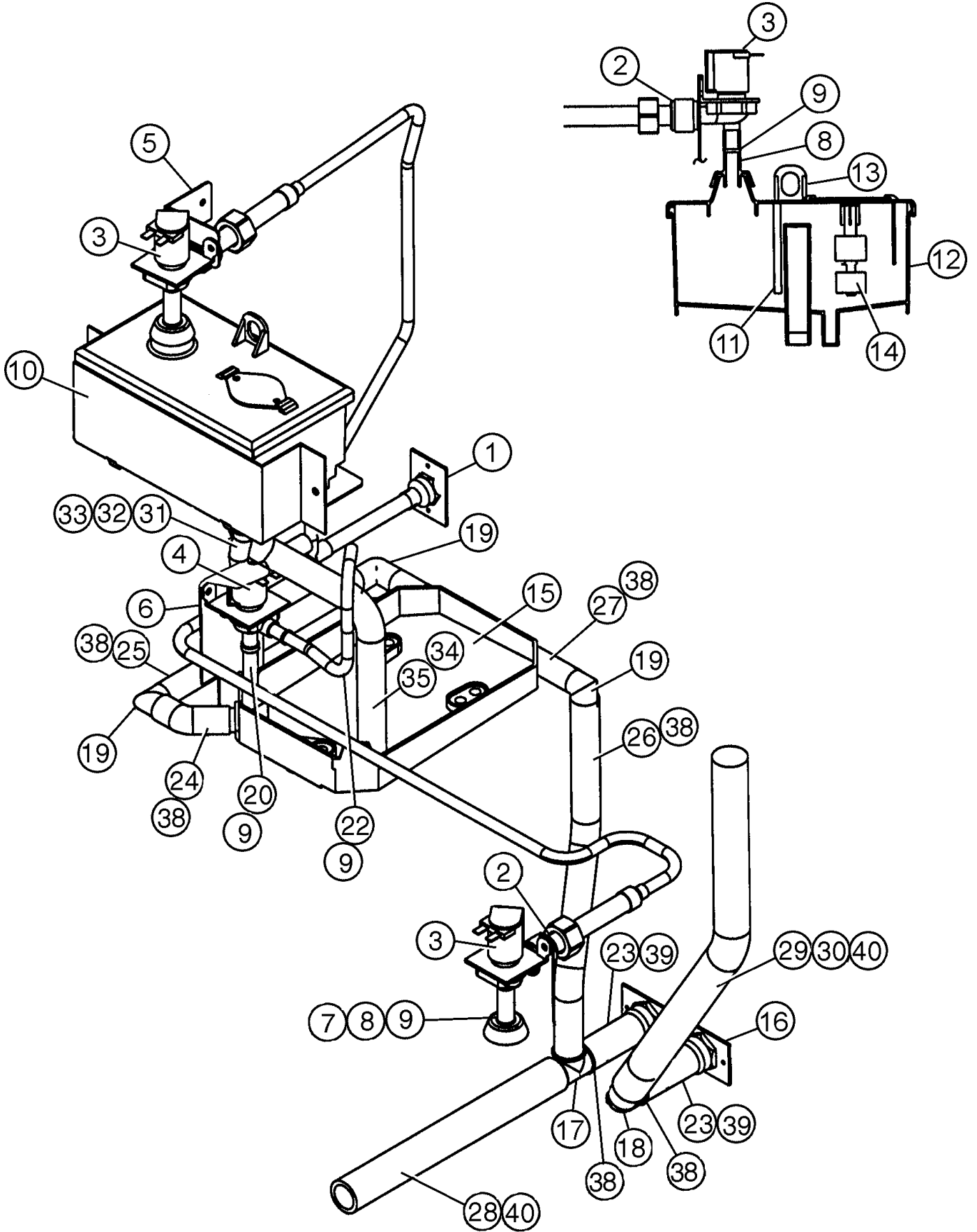



**MODEL: DCM-500BAF, BWF TITLE: E. WATER CIRCUIT**

INDEX NO.	DESCRIPTION	MATERIAL OR MODEL NUMBER	PART NUMBER	REQUIRED NUMBER							
				H-0	J-0	J-1	K-0	K-1 K-2	L-0 L-1	M-0 M-1	N-0
1	WATER SUPPLY PIPE	-	2A0680G01	1	1	1	1	1	1	1	1
	T2 SCREW	4 X 8	7P31-0408	2	2	2	2	2	2	2	2
2	WASHER	-	4A0867-01	2	2	2	2	2	2	2	2
3	WATER VALVE	-	4A0865-01	2	2	2	2	2	2	2	2
4	WATER VALVE	-	4A0866-01	1	1	1	x1				
		-	4A2077-01				o1	1	1	x1	
		-	4A2772-01							o1	1
	T2 SCREW	4 X 8	7P31-0408	6	6	6	6	6	6	6	6
5	WATER VALVE BRACKET (A)	-	4A0997-01	1	1	1	1	1	1	1	1
6	WATER VALVE BRACKET (B)	-	453927-01	1	x1						
		-	3A1421-01		o1	1	1	1	1	1	1
7	WATER VALVE BRACKET (C)	-	4A0999-01	1	1	1	1	1	1	1	1
	T2 SCREW	4 X 8	7P31-0408	4	4	4	4	4	4	4	4
	TRUSS HEAD SCREW	4 X 8	7C31-0408	2	2	2	2	2	2	2	2
8	INLET - RESERVOIR	-	4A0869-01	1	2	1	2	1	1	2	2
9	CLAMP	-	421642-04	5	5	x5					
		-	4A2017-08			o5	5	5	5	5	5
10	BRACKET - RESERVOIR	-	3A0356-01	1	1	1	1	1	1	1	1
	TRUSS HEAD SCREW	4 X 8	7C31-0408	2	2	2	2	2	2	2	2
11	SEPARATOR - RESERVOIR	-	4A1255-01	1	1	1	1	1	1	1	1
12	RESERVOIR	-	2A0753-01	1	1	1	1	1	1	1	1
13	RESERVOIR COVER	-	214810-01	1	1	1	1	1	1	1	1
14	FLOAT SWITCH	-	435490-01	1	1	1	1	1	1	1	1
15	DRAIN PAN	-	323765G02	1	1	1	1	1	1	1	1
16	FITTING	-	4A0776G01	2	2	2	2	2	2	2	2
	T2 SCREW	4 X 8	7P31-0408	4	4	4	4	4	4	4	4
17	TEE	-	4A0525-04	1	1	1	1	1	1	1	1
18	ELBOW	-	4A1016-01	1	1	1	1	1	1	1	1
19	ELBOW	-	4A1017-01	2	3	2	3	2	2	3	3

**MODEL: DCM-500BAF, BWF TITLE: E. WATER CIRCUIT**

INDEX NO.	DESCRIPTION	MATERIAL OR MODEL NUMBER	PART NUMBER	REQUIRED NUMBER							
				H-0	J-0	J-1	K-0	K-1 K-2	L-0 L-1	M-0 M-1	N-0
20	VINYL HOSE	L=70	7716-0913	1	1	1	x1				
	SILICONE HOSE	L=60	7716-0913				o1	1	1	1	1
21	-	-	-								
22	VINYL HOSE	L=310	7725-0912	1	1	1	1	1	1	1	1
23	VINYL HOSE	L=70	7716-2025	1	2	1	2	1	1	2	2
24	VINYL HOSE	L=50	7725-1923	1	1	1	1	1	1	1	1
25	VINYL HOSE	L=240	7725-1923	1	1	1	1	1	1	1	1
26	VINYL HOSE	L=320	7725-1923	1	1	1	1	1	1	1	1
27	VINYL HOSE	L=205	7725-1923	1	1	1	1	1	1	1	1
28	VINYL HOSE	L=250	4A0658L01	1	1	1	1	1	1	1	1
29	VINYL HOSE	L=385	4A0658L01	1	1	1	1	1	1	1	1
30	INSULATION HOSE	L=450	7762-2943	1	1	1	1	1	1	1	1
31	RESERVOIR HOSE	-	4A1165-02	1	1	1	1	1	1	1	1
32	CLAMP	-	435934-05	1	1	1	x1				
		-	4A2017-05				o1	1	1	1	1
33	CLAMP	-	435934-06	1	1	1	x1				
		-	4A2017-06				o1	1	1	1	1
34	CABLE TIE	-	7920-0003	18	18	2	2	2	2	2	2
35	VINYL HOSE	L=330	7725-1923	1	1						
36	COVER - WATER VALVE	-	340259-01	1	-						
37	T2 SCREW	4 X 8	7P31-0408	1	-						
38	HOSE CLAMP	-	4A2017-01			10	10	10	10	10	10
39	HOSE CLAMP	-	4A2017-02			2	2	2	2	2	2
40	HOSE CLAMP	-	4A2017-03			4	4	4	4	4	4

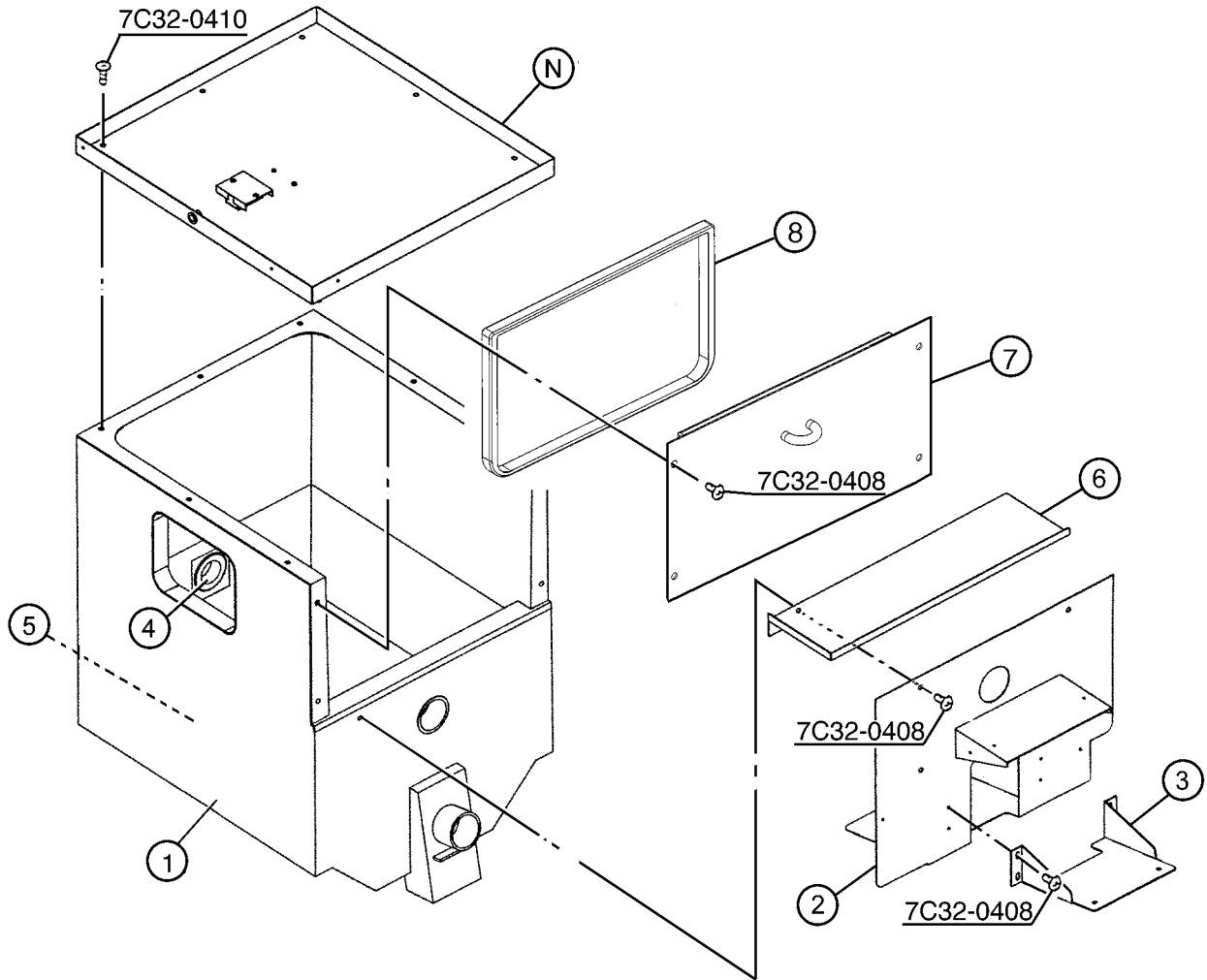

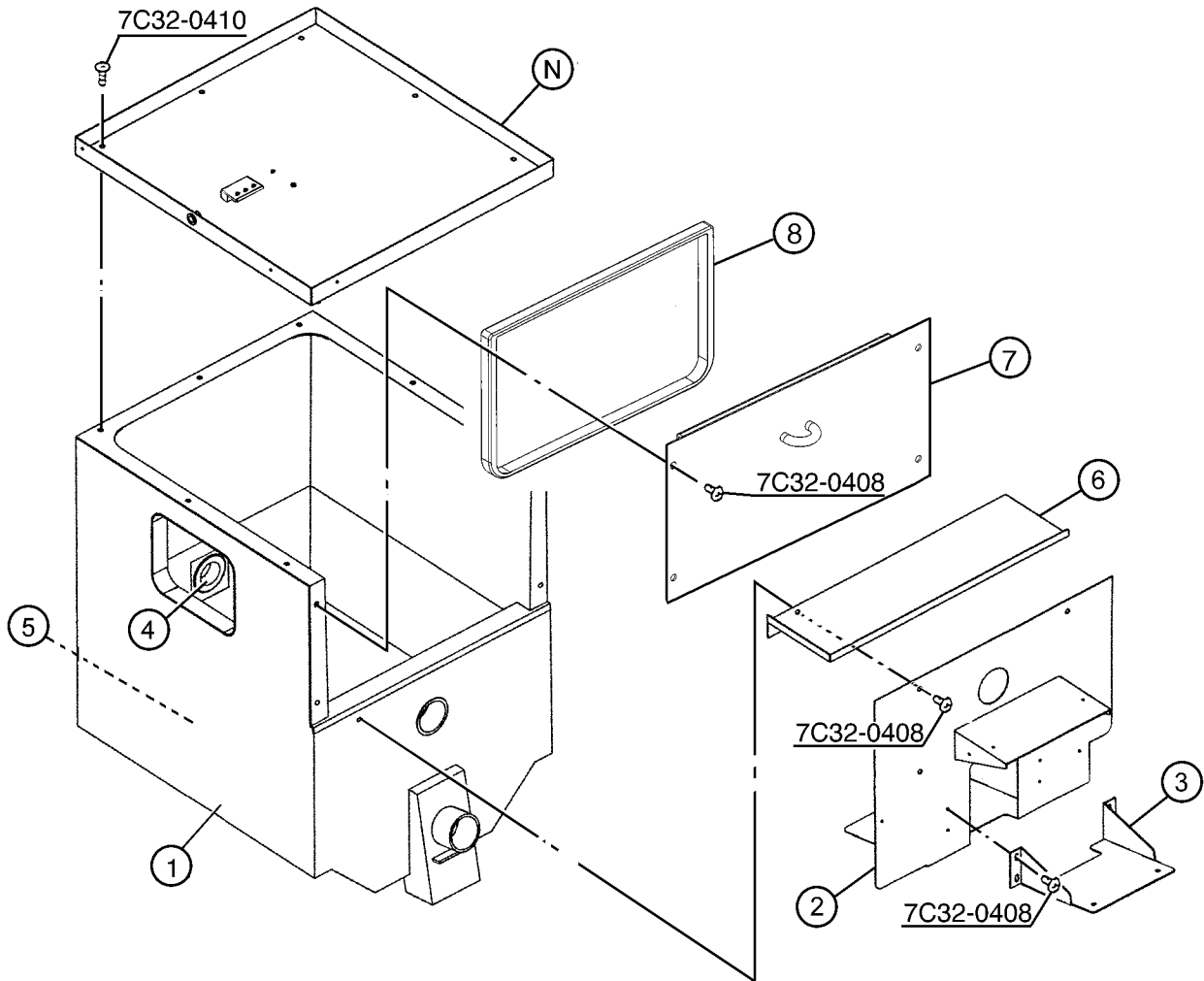

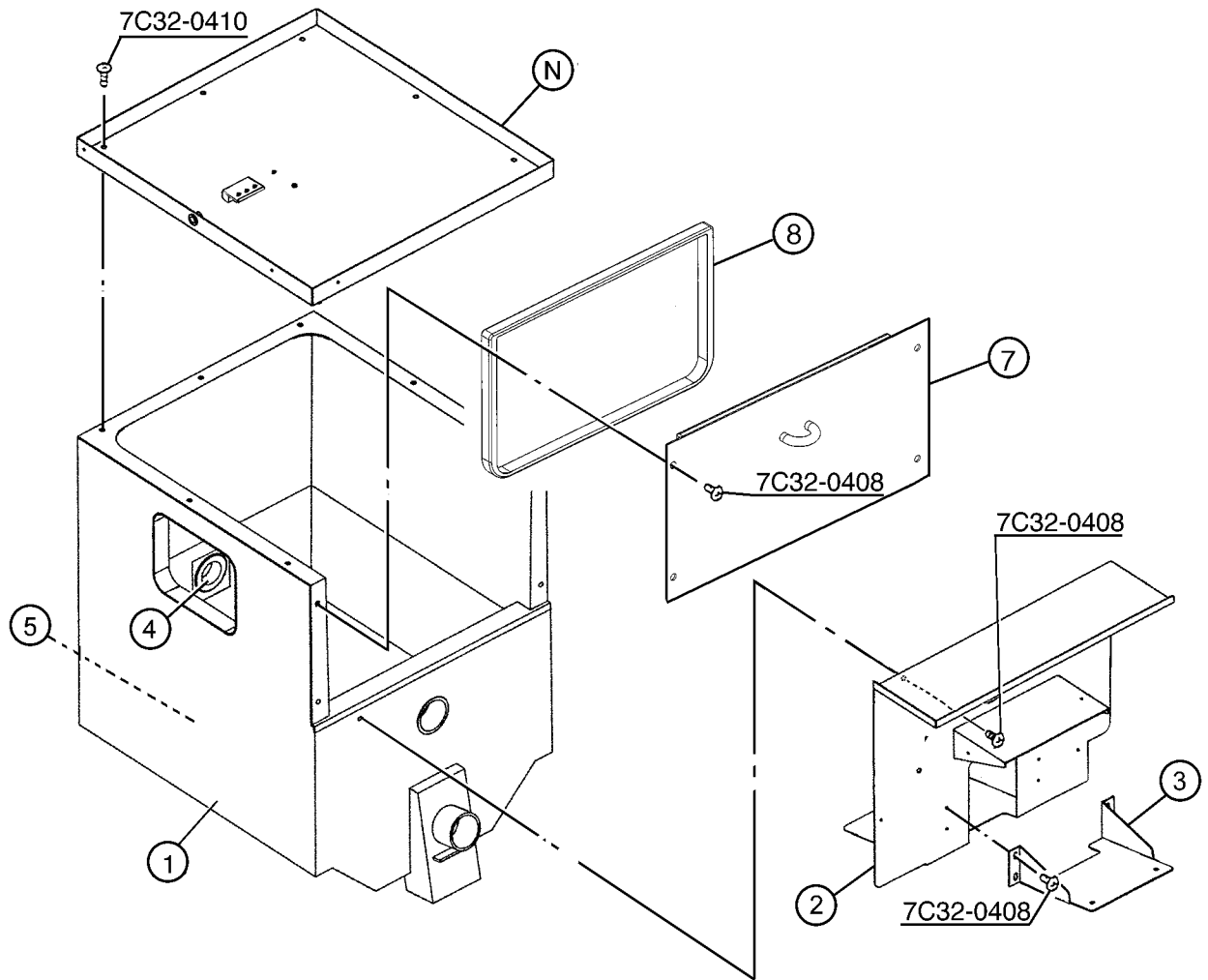



HA  
DCM-500BAF, BWF

G. GEAR MOTOR ASSEMBLY

H-0, J-0, J-1, K-0, K-1, K-2,  
L-0, L-1, M-0, M-1, N-0

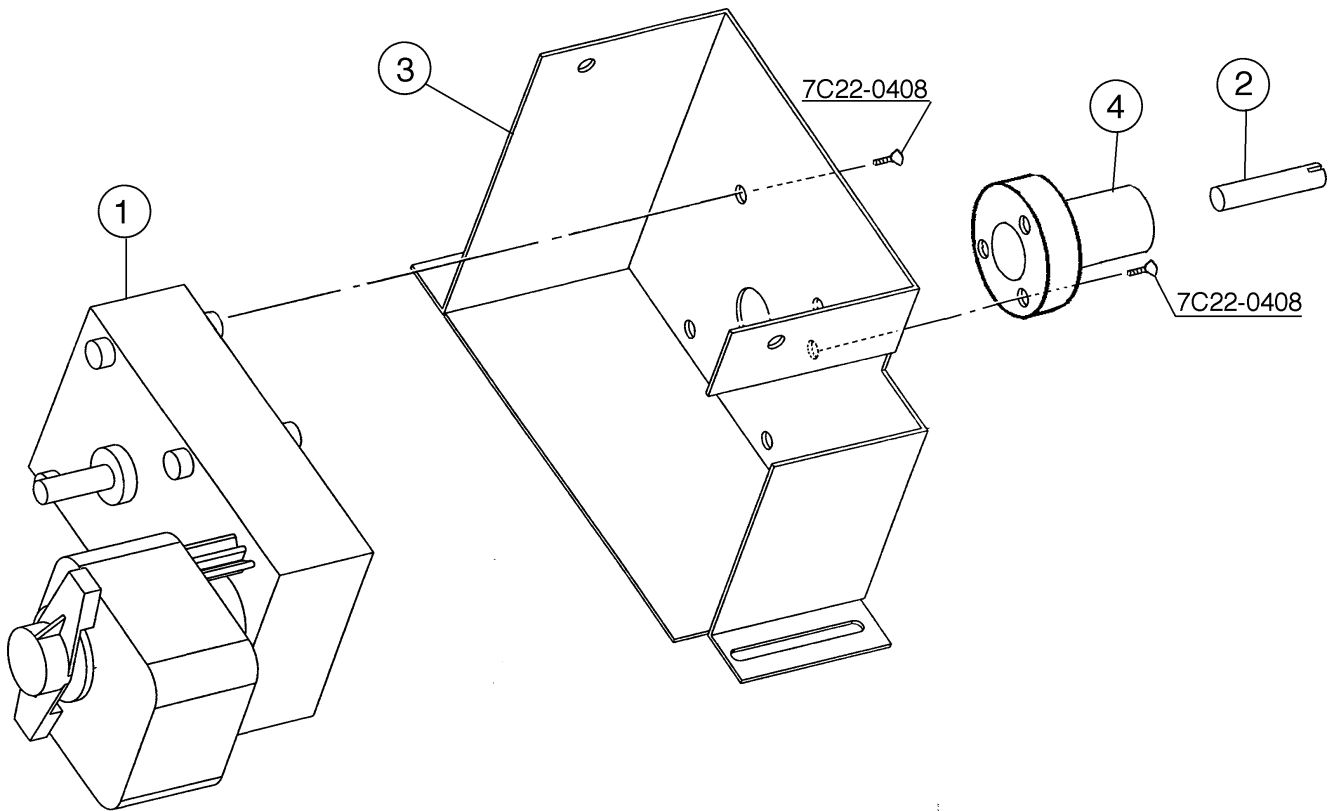





HA  
DCM-500BAF, BWF

H. GEAR MOTOR ASSEMBLY

H-0, J-0, J-1, K-0, K-1, K-2  
L-0, L-1, M-0, M-1, N-0

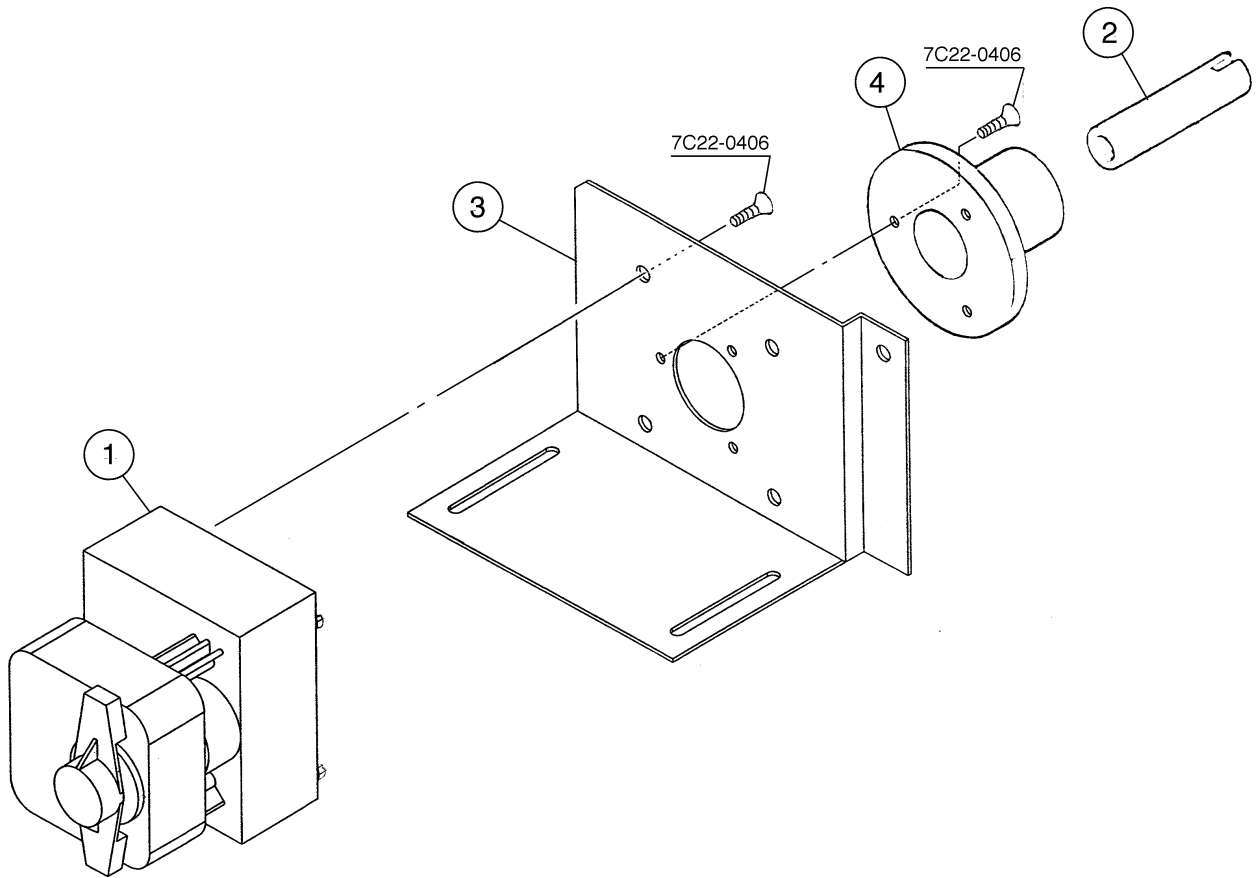



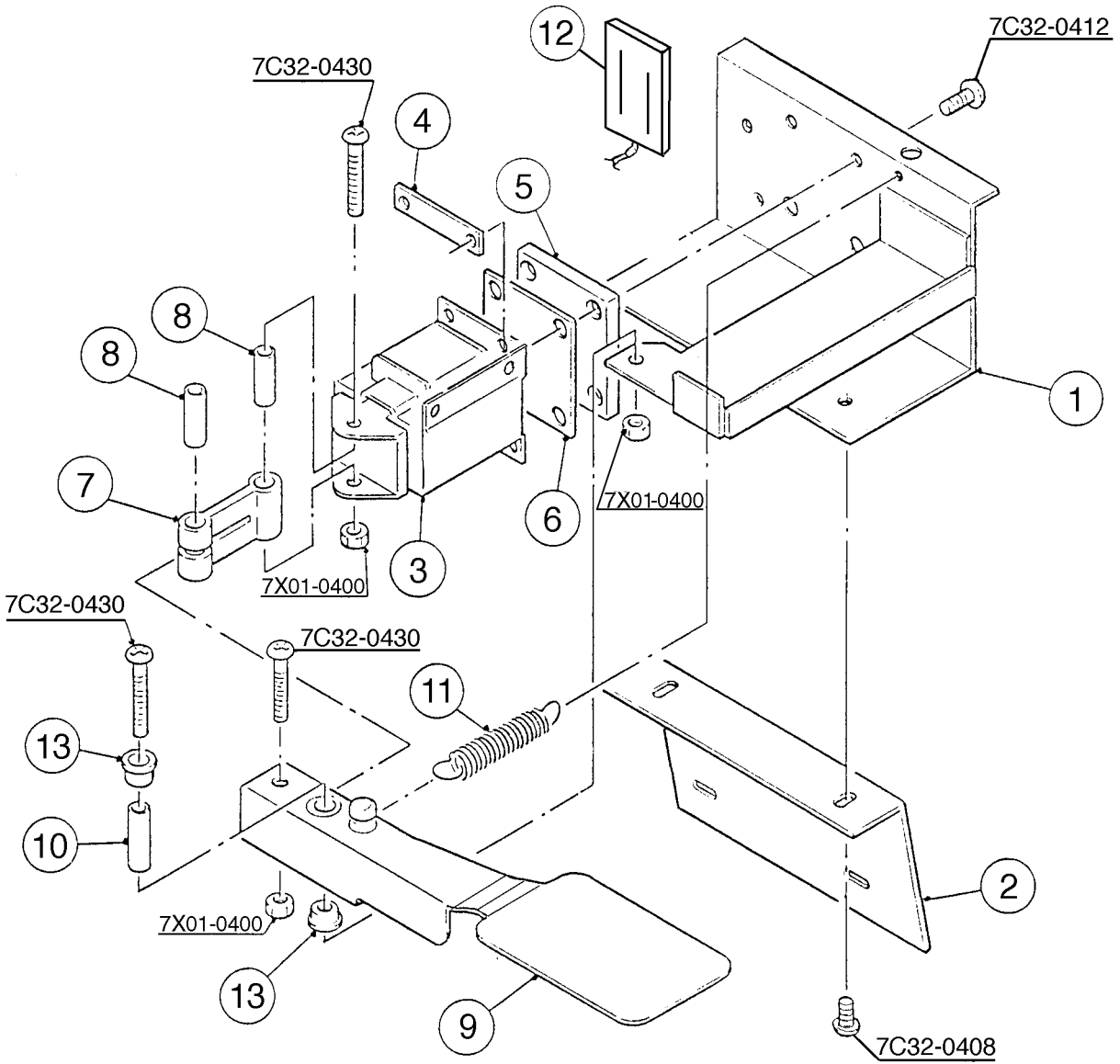

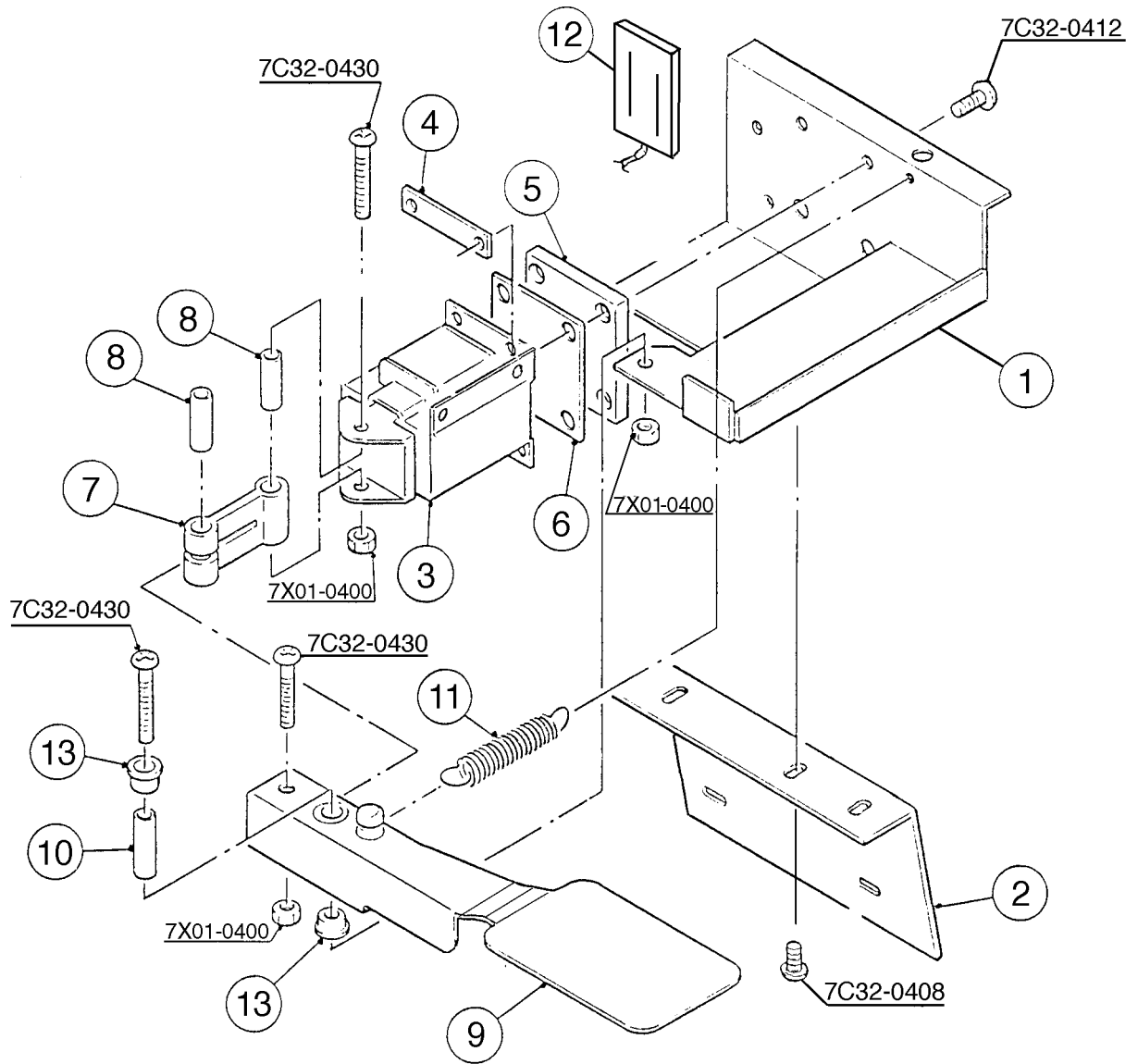

**MODEL: DCM-500BAF, BWF TITLE: J. SHUTTER ASSEMBLY**

INDEX NO.	DESCRIPTION	MATERIAL OR MODEL NUMBER	PART NUMBER	REQUIRED NUMBER							
				H-0	J-0	J-1	K-0 K-1	K-2	L-0 L-1	M-0 M-1	N-0
1	BASE - SHUTTER	-	3A0898G01	1	1	1	1	-			
		-	3A1817-01					1	1	1	1
2	BASE (B) - SHUTTER	-	320982-01	1	1	1	x1				
		-	3A1762-01				o1	1	1	1	1
	TRUSS HEAD SCREW	SS, 4 X 8	7C32-0408	2	2	2	2	2	2	2	2
3	SOLENOID	-	3U0095-01	1	1	1	1	1	1	1	1
4	SOLENOID NUT	-	429723-01	2	2	2	2	2	2	2	2
5	SOLENOID PACKING	-	430380-01	1	1	1	1	1	1	1	1
6	PACKING COVER	-	431623-01	1	1	1	1	1	1	1	1
	TRUSS HEAD SCREW	SS, 4 X 12	7C32-0412	4	4	4	4	4	4	4	4
7	LINK	-	432232-01	1	1	1	1	1	1	1	1
8	COLLAR (D)	-	432471-01	2	2	2	2	2	2	2	2
	TRUSS HEAD SCREW	SS, 4 X 30	7C32-0430	3	3	3	3	3	3	3	3
	"U" NUT	M4	7X01-0400	3	3	3	3	3	3	3	3
9	LEVER	-	318975G02	1	1	1	x1				
		-	3A1653G01				o1	1	1	1	1
10	COLLAR (E)	-	432240-02	1	1	1	1	1	1	1	1
11	SPRING	-	432878-01	1	1	1	1	1	1	1	1
12	NOISE SUPPRESSOR - R-C CAPACITOR	-	4A1012-01	1	1	1	1	1	1	1	1
13	PLASTIC SLEEVE INSERT	-	432235-01	2	2	2	2	2	2	2	2

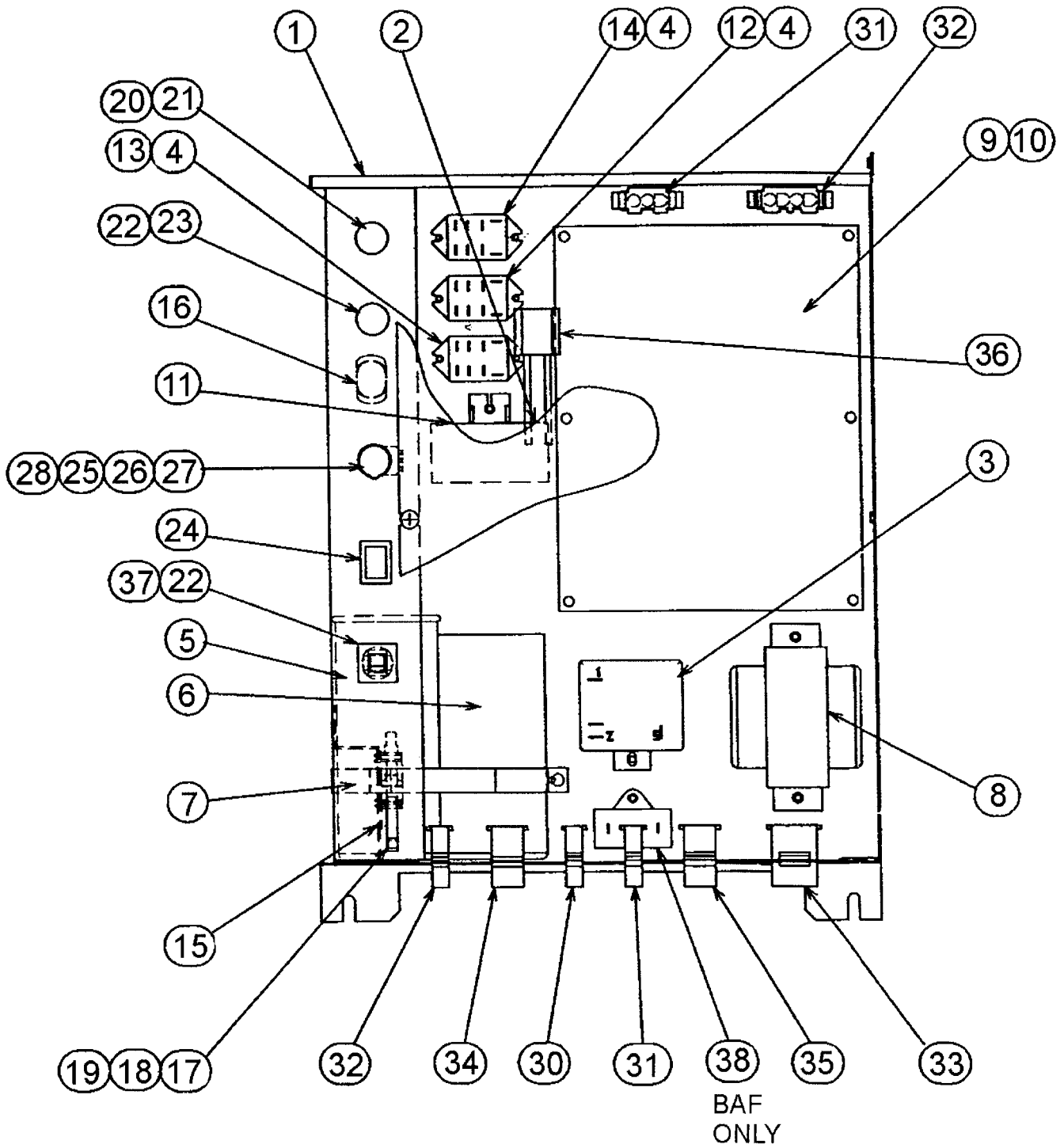

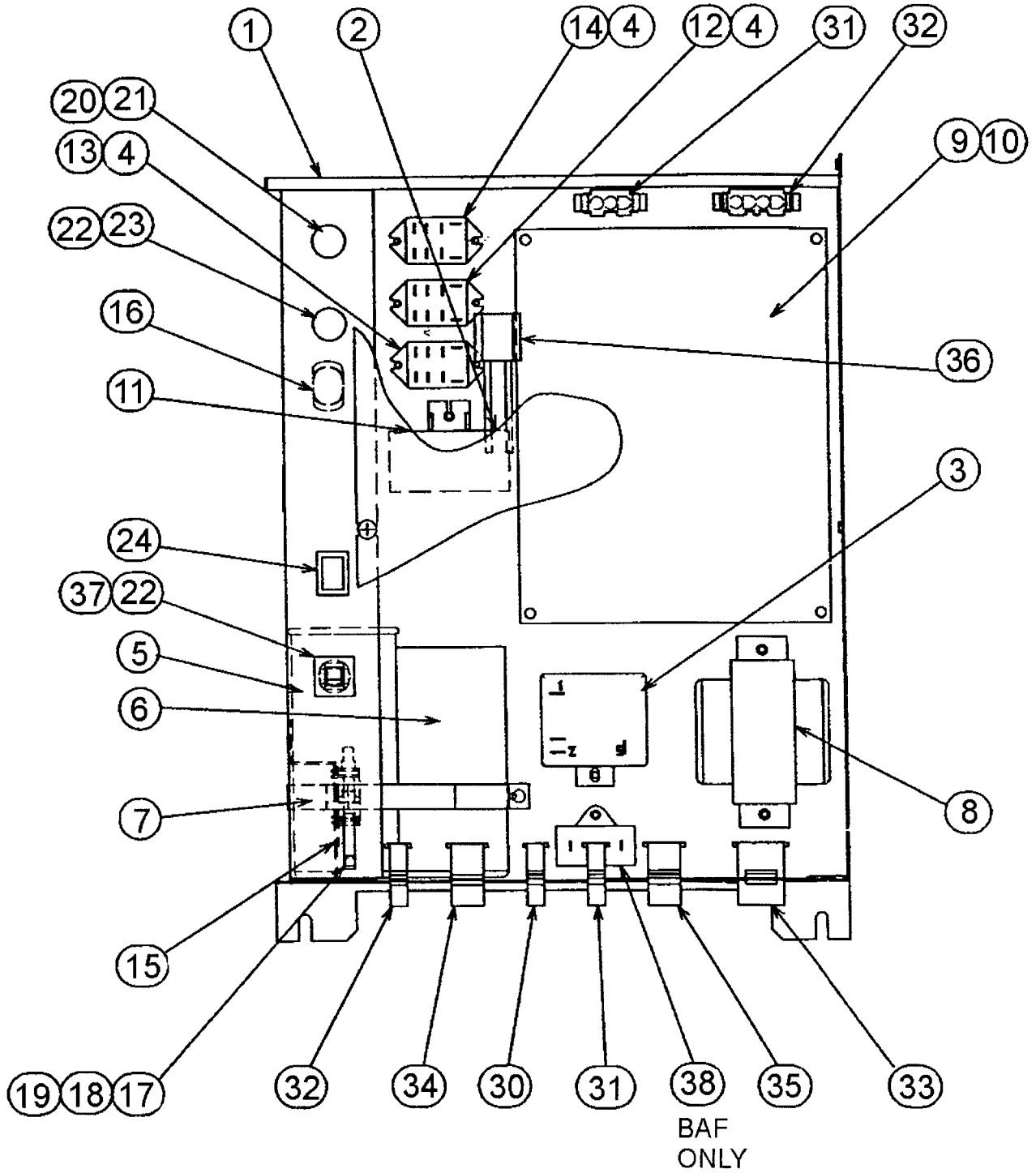

**MODEL: DCM-500BAF TITLE: K. CONTROL BOX ASSEMBLY**

INDEX NO.	DESCRIPTION	MATERIAL OR MODEL NUMBER	PART NUMBER	REQUIRED NUMBER							
				H-0	J-0	J-1	K-0 K-1	K-2	L-0	L-1	M-0 M-1 N-0
1	CONTROL BOX	-	227497G02	1	1	-					
		-	2A1638G01			1	1	1	1	1	1
2	COVER - CONTROL BOX	-	429931-01	1	1	1	1	1	1	1	1
	TRUSS HEAD SCREW	4 X 6	7C31-0406	2	2	2	2	2	2	2	2
3	STARTER	-	434172-04	1	1	1	1	1	x1		
		-	4A1107-01						o1	1	1
4	TAPPING SCREW	-	431415-01	6	6	6	6	6	6	6	6
5	CAPACITOR	-	439943-04	1	1	1	1	1	1	x1	
	RUN CAPACITOR	-	3A2005-08							o1	1
6	CAPACITOR - STARTING	-	3A0076-10	1	1	1	1	1	1	1	1
7	STRAP	-	434580-02	1	x1						
		-	434580-10		o1	1	1	1	1	x1	
		-	4A2262-02							o1	1
	T2 SCREW	4 X 8	7P31-0408	2	2	2	2	2	2	2	2
8	TRANSFORMER	TR5267-1	2U0042-02	1	1	1	1	1	1	1	1
	T2 SCREW	4 X 8	7P31-0408	2	2	2	2	2	2	2	2
9	TIMER BOARD	-	2U0098-02	1	1	-					
		-	2A1592-01			1	1	1	1	1	1
10	BOARD SUPPORT	-	4A0336-03	6	6	4	4	4	4	4	4
11	CAPACITOR	-	4A0894-01	1	1	1	1	1	1	1	1
	T2 SCREW	4 X 8	7P31-0408	1	1	1	1	1	1	1	1
12	RELAY	-	406132-07	1	1	1	1	1	1	1	1
13	RELAY	-	418271-05	1	1	1	1	1	1	1	1
14	RELAY	-	406132-03	1	1	1	1	1	1	1	1
15	SWITCH BRACKET	-	4A1013-01	1	1	1	1	1	1	1	1
	T2 SCREW	4 X 8	7P31-0408	2	2	2	2	2	2	2	2
16	BUSHING	-	420472-03	1	1	1	1	1	1	1	1
17	MICROSWITCH	-	4A0365-01	1	1	1	1	1	1	1	x1
		-	4A2546-01								o1



**MODEL: DCM-500BAF TITLE: K. CONTROL BOX ASSEMBLY**

INDEX NO.	DESCRIPTION	MATERIAL OR MODEL NUMBER	PART NUMBER	REQUIRED NUMBER							
				H-0	J-0	J-1	K-0 K-1	K-2	L-0	L-1	M-0 M-1 N-0
18	SPACER	-	429933-01	2	2	2	2	2	2	2	2
19	TAPPING SCREW	-	431415-02	2	2	2	2	2	2	2	2
20	FUSE HOLDER	-	4A0892-01	1	1	1	1	1	1	1	1
21	FUSE	-	4A0893-01	1	1	1	1	1	1	1	1
22	FUSE HOLDER	-	4A0892-02	2	2	2	2	2	2	2	2
23	FUSE	-	4A0893-02	1	1	1	1	1	1	1	1
24	ROCKER SWITCH	-	4A0558-01	1	1	1	1	1	1	1	1
25	VARIABLE RESISTOR	-	432858-01	1	1	-					
26	SPACER	-	439775-01	1	1	-					
27	LABEL - CONTROL	-	433295-01	1	1	-					
28	KNOB	-	318744-01	1	1	-					
29	-	-	-								
30	2P PLUG HOUSING	-	412832-07	1	1	1	1	1	1	1	1
31	3P PLUG HOUSING	-	412832-06	2	2	2	2	2	2	2	2
32	4P PLUG HOUSING	-	412832-05	2	2	2	2	2	2	2	2
33	9P PLUG HOUSING	-	412832-02	1	1	1	1	1	1	1	1
34	6P PLUG HOUSING	-	412832-03	1	1	1	1	1	1	1	1
35	4P PLUG HOUSING (RED)	-	412832-11	1	1	1	1	1	1	1	1
36	R-C CAPACITOR – NOISE SUPPRESSOR	-	4A1012-01	1	1	1	1	1	1	1	1
37	FUSE	-	4A0893-04	1	1	1	1	1	1	1	1
38	CAPACITOR	-	443192-02	1	1	1	1	1	1	1	1
	T2 SCREW	4X8	7P31-0408	1	1	1	1	1	1	1	1

MODEL: DCM-500BWF TITLE: K. CONTROL BOX ASSEMBLY											
INDEX NO.	DESCRIPTION	MATERIAL OR MODEL NUMBER	PART NUMBER	REQUIRED NUMBER							
				H-0	J-0	J-1	K-0	K-1	K-2	L-0	M-0 M-1 N-0
1	CONTROL BOX	-	227497G02	1	1	-					
		-	2A1638G01			1	1	1	1	1	1
2	COVER - CONTROL BOX		429931-01	1	1	1	1	1	1	1	1
	TRUSS HEAD SCREW	4 X 6	7C31-0406	2	2	2	2	2	2	2	2
3	STARTER	-	434172-04	1	1	1	1	1	o1		
		-	4A1107-01						x1	1	1
4	TAPPING SCREW	-	431415-01	6	6	6	6	6	6	6	6
5	CAPACITOR	-	439943-04	1	1	1	1	1	1	x1	
	RUN CAPACITOR	-	3A2005-08							o1	1
6	CAPACITOR - STARTING	-	3A0076-10	1	1	1	1	1	1	1	1
7	STRAP	-	434580-02	1	x1						
		-	434580-10		o1	1	1	1	1	x1	
		-	434580-10							o1	1
	T2 SCREW	4 X 8	7P31-0408	2	2	2	2	2	2	2	2
8	TRANSFORMER	TR5267-1	2U0042-02	1	1	1	1	1	1	1	1
	T2 SCREW	4 X 8	7P31-0408	2	2	2	2	2	2	2	2
9	TIMER BOARD	-	2U0098-02	1	1	-					
		-	2A1592-01			1	1	1	1	1	1
10	BOARD SUPPORT	-	4A0336-03	6	6	4	4	4	4	4	4
11	CAPACITOR	-	4A0894-01	1	1	1	1	1	1	1	1
	T2 SCREW	4 X 8	7P31-0408	1	1	1	1	1	1	1	1
12	RELAY	-	406132-07	1	1	1	1	1	1	1	1
13	RELAY	-	418271-05	1	1	1	1	1	1	1	1
14	RELAY	-	406132-03	1	1	1	1	1	1	1	1
15	SWITCH BRACKET	-	4A1013-01	1	1	1	1	1	1	1	1
	T2 SCREW	4 X 8	7P31-0408	2	2	2	2	2	2	2	2
16	BUSHING	-	420472-03	1	1	1	1	1	1	1	1
17	MICROSWITCH	-	4A0365-01	1	1	1	1	1	1	x1	
		-	4A2546-01							o1	1

**MODEL: DCM-500BWF TITLE: K. CONTROL BOX ASSEMBLY**

INDEX NO.	DESCRIPTION	MATERIAL OR MODEL NUMBER	PART NUMBER	REQUIRED NUMBER							
				H-0	J-0	J-1	K-0	K-1	K-2	L-0	M-0 M-1 N-0
18	SPACER	-	429933-01	2	2	2	2	2	2	2	2
19	TAPPING SCREW	-	431415-02	2	2	2	2	2	2	2	2
20	FUSE HOLDER	-	4A0892-01	1	1	1	1	1	1	1	1
21	FUSE	-	4A0893-01	1	1	1	1	1	1	1	1
22	FUSE HOLDER	-	4A0892-02	2	2	2	2	2	2	2	2
23	FUSE	-	4A0893-02	1	1	1	1	1	1	1	1
24	ROCKER SWITCH	-	4A0558-01	1	1	1	1	1	1	1	1
25	VARIABLE RESISTOR	-	432858-01	1	1	-					
26	SPACER	-	439775-01	1	1	-					
27	LABEL - CONTROL	-	433295-01	1	1	-					
28	KNOB	-	318744-01	1	1	-					
29	-	-	-								
30	2P PLUG HOUSING	-	412832-07	1	1	1	1	1	1	1	1
31	3P PLUG HOUSING	-	412832-06	2	2	2	2	2	2	2	2
32	4P PLUG HOUSING	-	412832-05	2	2	2	2	2	2	2	2
33	9P PLUG HOUSING	-	412832-02	1	1	1	1	1	1	1	1
34	6P PLUG HOUSING	-	412832-03	1	1	1	1	1	1	1	1
35	4P PLUG HOUSING (RED)	-	412832-11	1	1	1	1	1	1	1	1
36	R-C CAPACITOR – NOISE SUPPRESSOR	-	4A1012-01	1	1	1	1	1	1	1	1
37	FUSE	-	4A0893-04	1	1	1	1	1	1	1	1

HA

DCM-500BAF, BWF L. MIDDLE FRONT PANEL ASSEMBLY

H-0, J-0, J-1, K-0, K-1, K-2

L-0, L-1, M-0, M-1, N-0

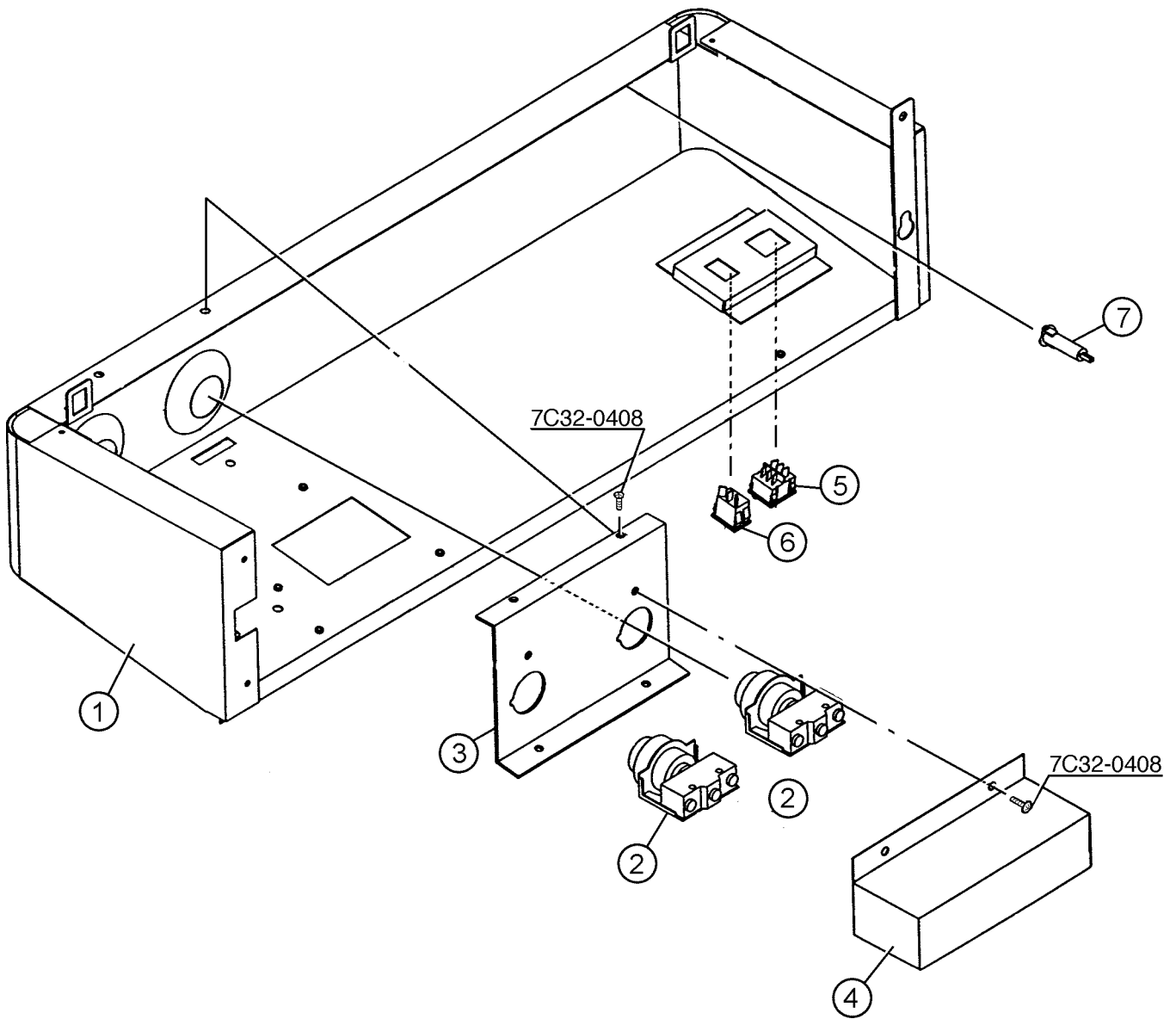



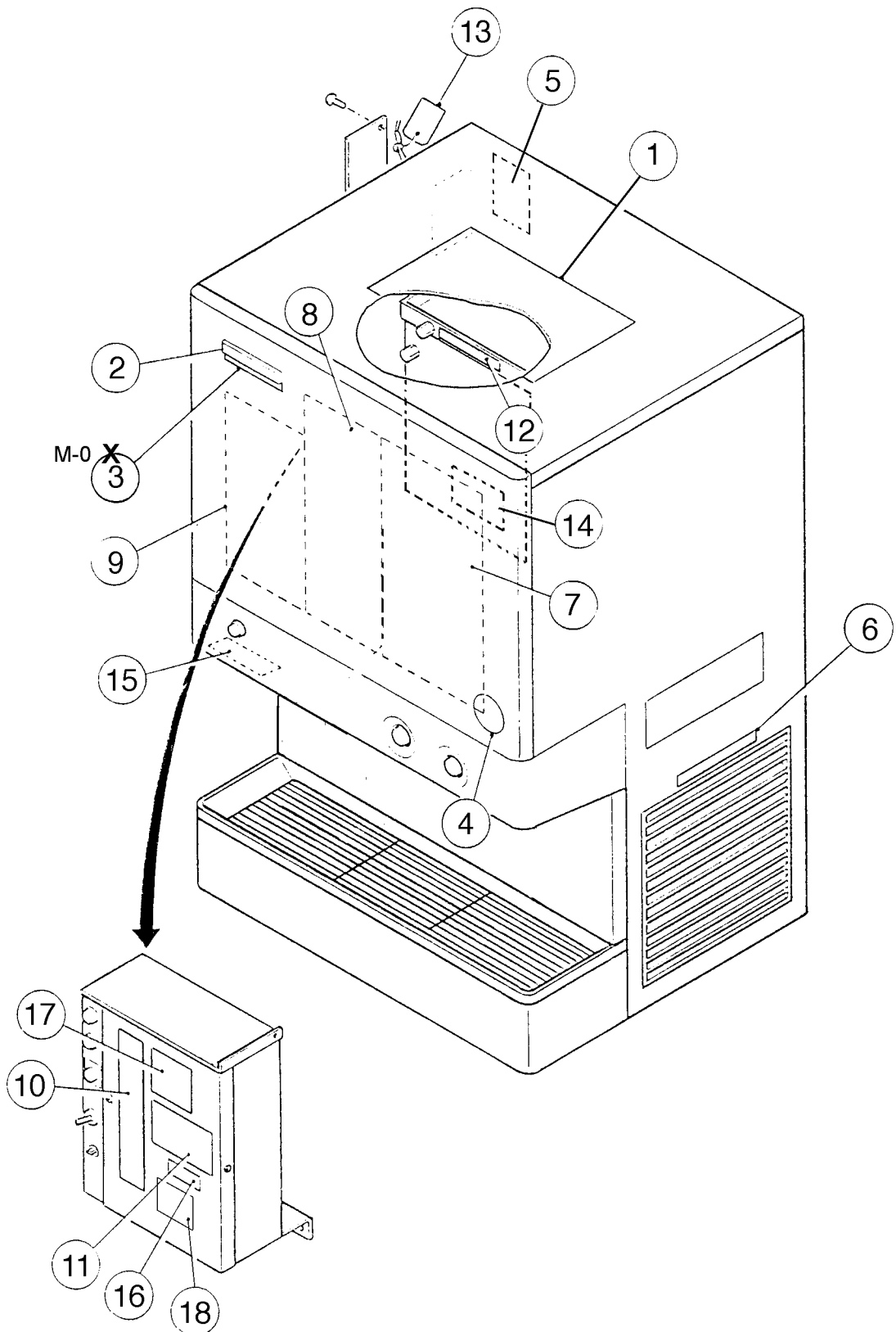

**MODEL: DCM-500BAF TITLE: M. LABEL LOCATION**

INDEX NO.	DESCRIPTION	MATERIAL OR MODEL NUMBER	PART NUMBER	REQUIRED NUMBER								
				H-0	J-0	J-1	K-0 K-1	K-2	L-0	L-1	M-0 N-0	
1	INSTRUCTION SHEET	-	2A0709-01	1	1	1	1	1	1	1	1	1
2	EMBLEM	-	4A0560-01	1	1	1	1	1	1	1	1	1
3	MODEL NUMBER LABEL	-	4A1321-15	1	1	1	1	1	1	1	1	-
4	LABEL - PENGUIN - HA - L	-	4A0526-02	1	1	1	1	1	1	1	1	1
5	NAMEPLATE	-	453885-01	1	1	1	1	1	1	1	1	x1
		-	3A2532-01									o1
6	LABEL - AIR FILTER	-	426177-01	1	1	1	1	1	1	1	1	1
7	INSTRUCTION LABEL	-	227630-01	1	1	-						
		-	3A1646-01			1	1	1	1	1	1	1
8	LABEL - CLEANING	-	2A0710-01	1	1	1	1	1	1	1	1	1
9	WIRING LABEL	-	3A1308-01	1	-							
		-	3A1425-01		1	-						
		-	3A1457-01			1	1	1	1	1	1	1
10	LABEL - SWITCH, FUSE	-	4A1879-01	1	1	1	1	1	1	1	1	1
11	CAUTION LABEL (J)	-	439149-01	1	1	1	1	1	1	1	1	1
12	LABEL-CAUTION: TOP PANEL	-	430439-01	1	1	1	1	1	1	1	1	1
13	TAG - WARNING: ELECTRICAL CONNECTION	-	435005-01	1	1	1	1	1	1	1	1	1
14	INSTRUCTION SHEET - BIN COVER	-	446463-01	1	1	1	1	1	1	1	1	1
15	LABEL - SWITCH	-	4A1038-01	1	1	1	1	1	1	1	1	1
16	LABEL - R404A	-	4A0960-01	1	1	1	1	1	1	1	1	1
17	RATING LABEL	-	4A1688-01	1	1	1	1	1	1	1	1	x1
		-	3A2533-01									o1
18	LABEL - (GM) FUSE	-	4A1614-01	1	1	1	1	1	1	1	1	1

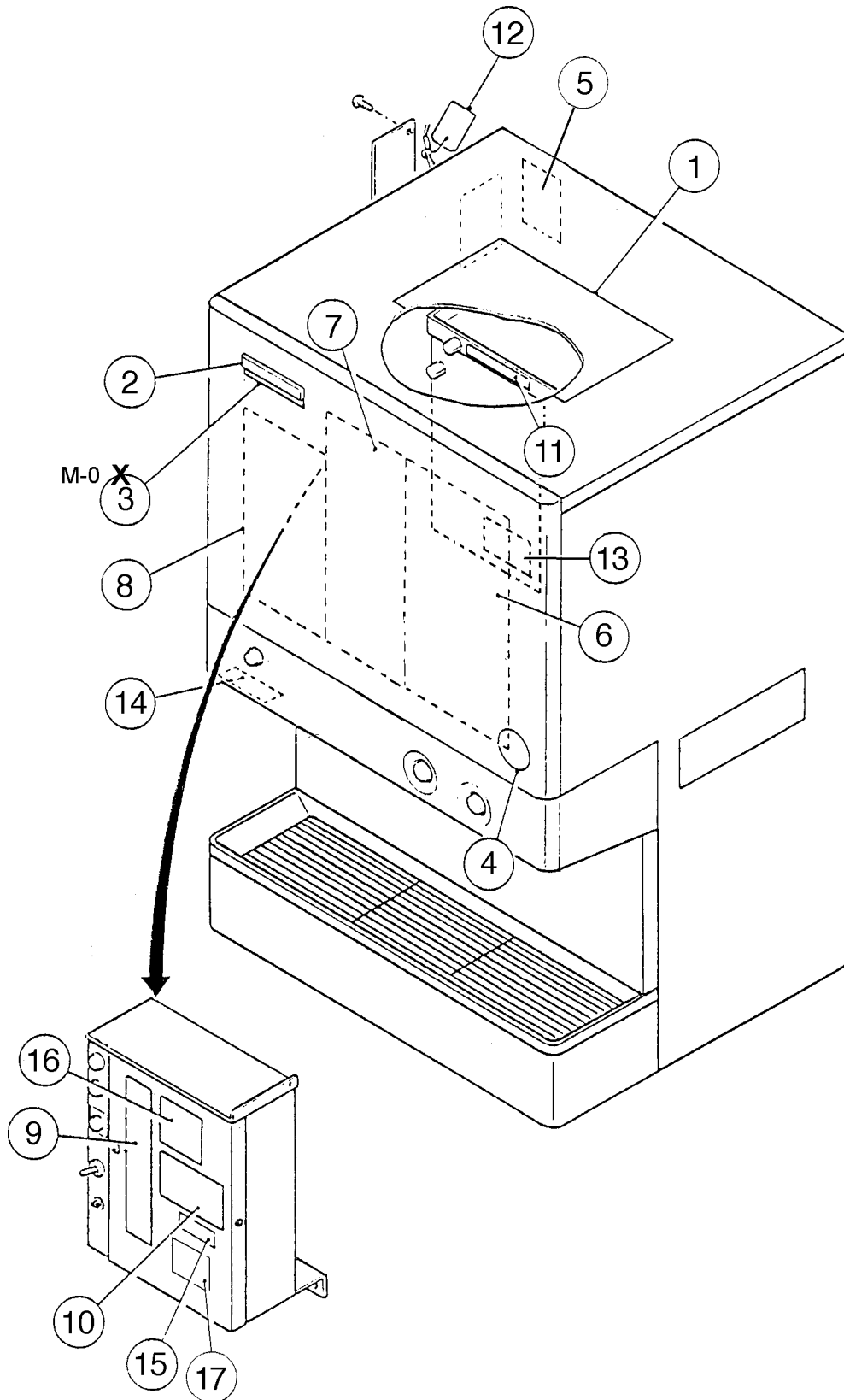



**MODEL: DCM-500BWF TITLE: M. LABEL LOCATION**

INDEX NO.	DESCRIPTION	MATERIAL OR MODEL NUMBER	PART NUMBER	REQUIRED NUMBER							
				H-0	J-0	J-1	K-0 K-1	K-2	L-0	M-0	M-1 N-0
1	INSTRUCTION SHEET	PAPER	2A0709-01	1	1	1	1	1	1	1	1
2	EMBLEM	-	4A0560-01	1	1	1	1	1	1	1	1
3	MODEL NUMBER LABEL	-	4A1321-16	1	1	1	1	1	1	-	
4	LABEL - PENGUIN - HA - L	-	4A0526-02	1	1	1	1	1	1	1	1
5	NAMEPLATE	-	453886-01	1	1	1	1	1	1	1	-
		-	3A2532-02								1
6	INSTRUCTION LABEL	-	227630-01	1	1	-					
			2A1646-01			1	1	1	1	1	1
7	LABEL - CLEANING	-	2A0710-01	1	1	1	1	1	1	1	1
8	WIRING LABEL	-	3A1308-01	1	-						
		-	3A1425-01		1	-					
		-	3A1457-01			1	1	1	1	1	1
9	LABEL - SWITCH, FUSE	-	4A1879-01	1	1	1	1	1	1	1	1
10	CAUTION LABEL (J)	-	439149-01	1	1	1	1	1	1	1	1
11	LABEL-CAUTION: TOP PANEL	-	430439-01	1	1	1	1	1	1	1	1
12	TAG - WARNING: ELECTRICAL CONNECTION	-	435005-01	1	1	1	1	1	1	1	1
13	INSTRUCTION SHEET - BIN COVER	-	446463-01	1	1	1	1	1	1	1	1
14	LABEL - SWITCH	-	4A1038-01	1	1	1	1	1	1	1	1
15	LABEL- R404A	-	4A0960-01	1	1	1	1	1	1	1	1
16	RATING LABEL	-	4A1689-01	1	1	1	1	1	1	1	-
		-	3A2533-02								1
17	LABEL - (GM) FUSE	-	4A1614-01	1	1	1	1	1	1	1	1

