



# HOSHIZAKI

## Parts List

Cubelet Icemaker/Dispenser

Models

DCM-500BAH-OS

DCM-500BWH-OS



[hoshizakiamerica.com](http://hoshizakiamerica.com)

Number: 71212  
Issued: 11-26-2002  
Revised: 9-5-2017

## CONTENTS

Auxiliary Codes.....	3
Note About Ordering Parts .....	3
A. Main Assembly .....	4
DCM-500BAH-OS .....	4
DCM-500BWH-OS .....	7
B. Refrigeration Circuit.....	10
DCM-500BAH-OS .....	10
DCM-500BWH-OS .....	12
C. Icemaking Unit .....	14
D. Water Circuit .....	16
E. Control Box Assembly.....	18
F. Apron Panel Assembly .....	20
G. Middle Front Frame Assembly.....	21
H. Shutter Assembly.....	22
J. Gear Motor Assembly (Agitator) .....	25
K. Gear Motor Assembly (Dispense).....	26
L. Bin Assembly .....	27
M. Bin Top Assembly.....	28
N. Accessories & Labels .....	29

## Auxiliary Codes

### DCM-500BAH-OS

M-0	October 2002
N-0	December 2002
N-1	November 2003
P-0	December 2003
P-1	June 2004
Q-0	December 2004
Q-1	February 2005
R-0	December 2005
S-0	January 2007
S-1	November 2007
T-0	January 2008
T-1	October 2008
U-0	February 2009
U-1	August 2009
V-0	January 2010
V-2	May 2010
V-3	June 2010
V-4	October 2010
V-1	November 2010
A-0	January 2011
A-1	June 2011
B-0	January 2012
C-0	January 2013
C-1	November 2013
D-0	January 2014
E-0	January 2015
F-0	January 2016
G-0	January 2017

### DCM-500BWH-OS

N-0	December 2002
N-1	September 2003
P-0	March 2004
Q-0	January 2005
Q-1	October 2005
R-0	January 2006
S-0	January 2007
S-1	December 2007
T-0	January 2008
U-0	January 2009
U-1	October 2009
V-0	February 2010
V-2	May 2010
V-3	June 2010
V-4	September 2010
V-1	November 2010
A-0	January 2011
A-1	June 2011
B-0	January 2012
C-0	January 2013
C-1	November 2013
D-0	January 2014
E-0	January 2015
F-0	April 2016
G-0	January 2017

## Auxiliary Code Breakdown

The auxiliary code is the first two characters in the serial number. The first character indicates the year. Years progress or regress in alphabetical order. The series runs from "A" through "V" and the letters "I" and "O" are skipped. The second character indicates significant part changes within a year. Base is "0" and this number advances for each change. In cases where there is a letter in parentheses, this designates the month. This is the last character in the serial number. The series runs from "(A)" through "(M)" and the letter "(I)" is skipped. This designation is only included when identifying a parts change within an auxiliary code.

## Note About Ordering Parts

Most assemblies cannot be ordered as complete units; parts in the assemblies generally must be ordered separately.

**A. Main Assembly**  
**DCM-500BAH-OS**  
**1/2**  
M-0 to G-0

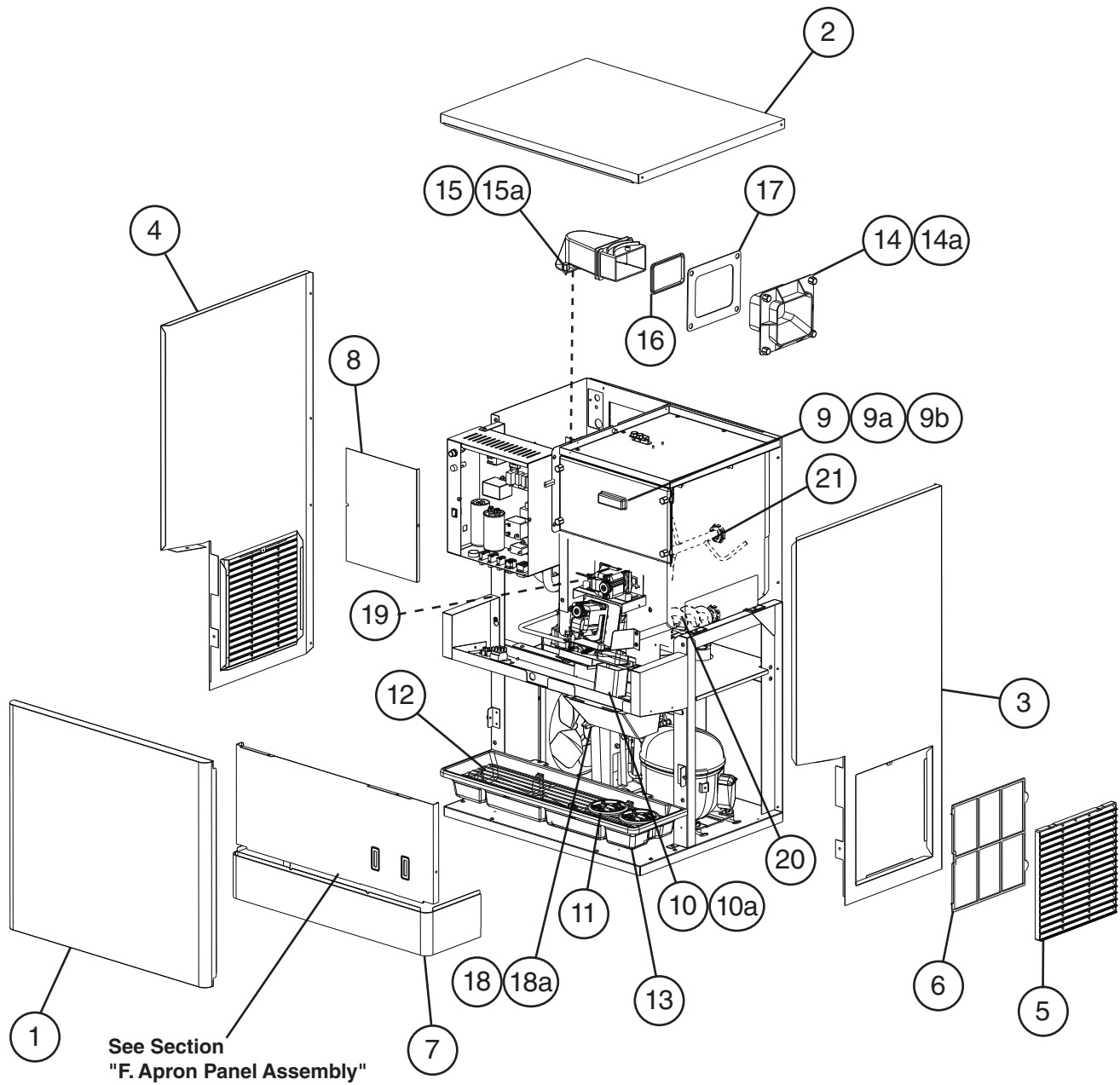

**A. Main Assembly**  
**DCM-500BAH-OS**  
**2/2**  
M-0 to G-0

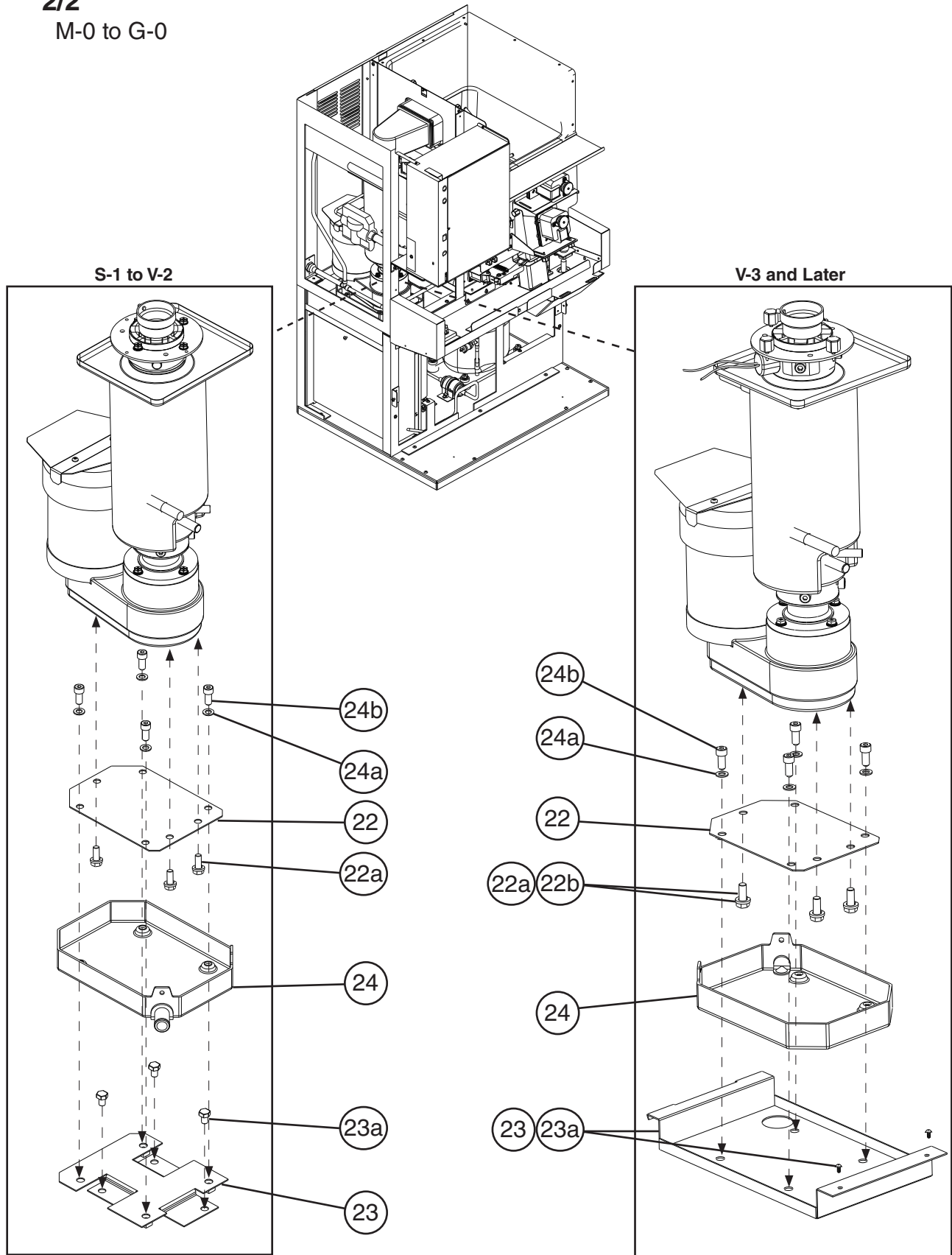

Title: A. Main Assembly Model: DCM-500BAH-OS											
Index No.	Description	Material or Model Number	Part Number	Required Number							
				M-0 to S-0	S-1 to U-0	U-1 to V-2	V-3 to G-0				
1	Front Panel		3A2853G01	1	1	-					
			2A2891-01			1	1				
2	Top Panel		3A2514G01	1	1	1	1				
3	Right Side Panel		2A2617-01	1	1	1	-				
			2A6143-02				1				
4	Left Side Panel		2A2616-01	1	1	1	-				
			2A6144-01				1				
5	Louver		103121-03	2	2	2	2				
6	Air Filter		208283G03	1	1	1	1				
7	Middle Panel (Lo)		2A0699G01	1	1	1	1				
8	Control Box Cover		4A5054-01	1	1	1	1				
9	Bin Cover		2A0880A02	1	1	1	1				
9a	Thumbscrew		415949G12	4	4	4	4				
9b	Bin Cover Gasket		318984G01	1	1	1	1				
10	Ice Chute		4A2204-01	1	1	1	1				
10a	Thumbscrew		415949G08	2	2	2	2				
11	Cup Guide		326702-01	2	2	2	2				
12	Grille		2A0827G01	1	1	1	1				
13	Drip Tray		2A2591G01	1	1	1	1				
14	Spout (B)		208807-01	1	1	1	1				
14a	Thumbscrew		415949G11	4	4	4	4				
15	Spout		103329G01	1	1	1	1				
15a	Thumbscrew		415949G11	3	3	3	3				
16	Packing (A) Spout		427195-01	1	1	1	1				
17	Packing (B) Spout		427196-01	1	1	1	1				
18	Spout Cover		215773-01	1	1	1	1				
18a	Thumbscrew		415949G08	2	2	2	2				
19	Gasket		429758-01	2	2	2	2				
20	Dispense Auger		339192G01	1	1	1	1				
21	Agitator		3A0895G01	1	1	1	1				
22	Gear Motor Bracket		4A4308-01		1	1	1				
22a	Hex Head Bolt	8x12, SS	7B02-0812		3	3	3				
22b	Split Lock Washer	M8, SS	7L22-0800				3				
23	Drain Pan Bracket		4A4315G01	1	1	1	-				
			2A5389G01				1				
23a	Hex Head Bolt	8x12, SS	7B02-0812		3	3	-				
	FT Screw	4x8	7F32-0408				4				
24	Drain Pan		323765G02	1	-						
			4A4354G01		1	1	-				
			4A4354G02					1			
24a	Flat Washer	M8, SS	7W22-0800		4	4	4				
24b	Allen Head Cap Screw	8x20, SS	7S12-0820		4	4	4				

**A. Main Assembly**  
**DCM-500BWH-OS**  
**1/2**  
N-0 to G-0

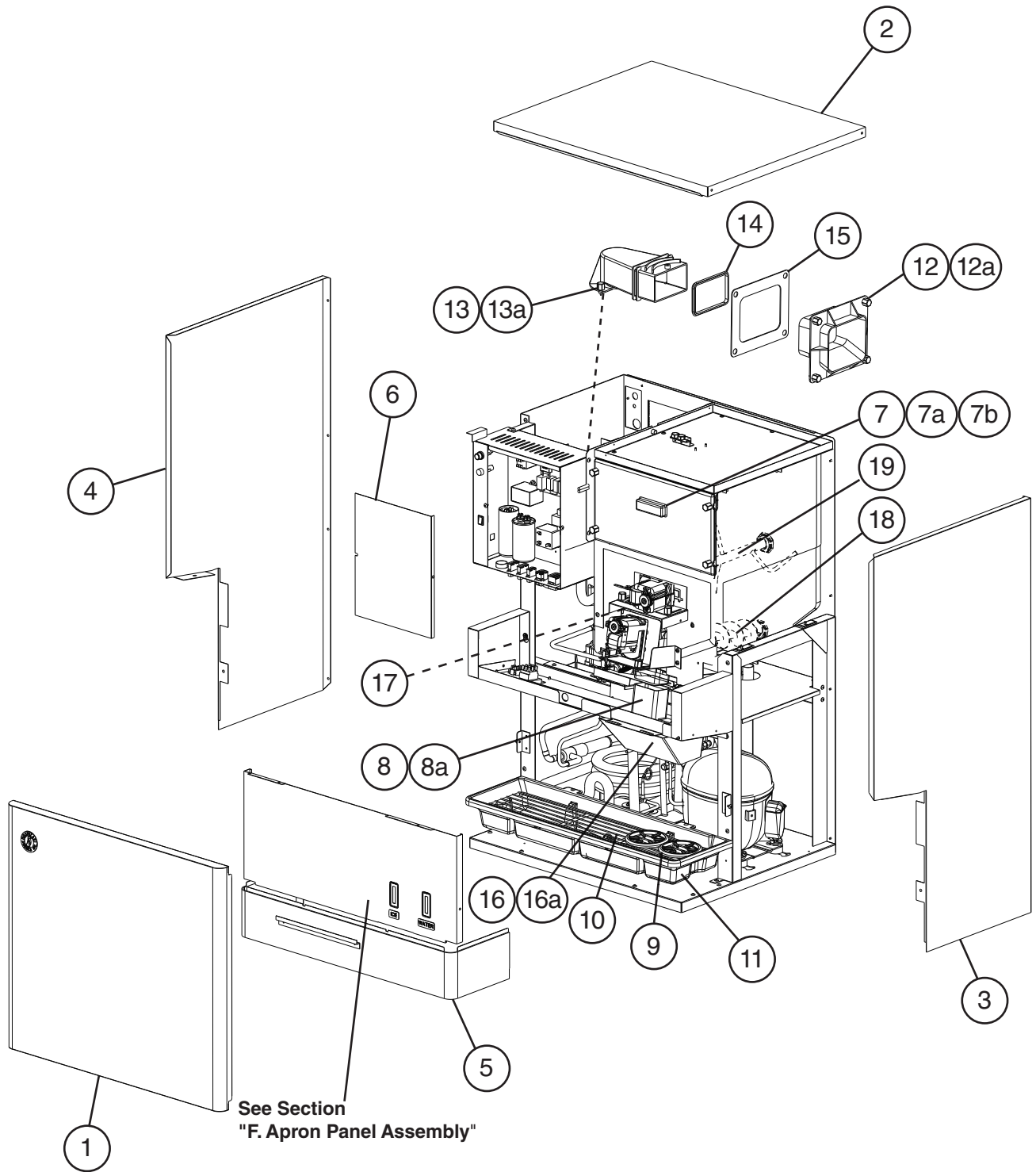

**A. Main Assembly**  
**DCM-500BWH-OS**  
**2/2**  
N-0 to G-0

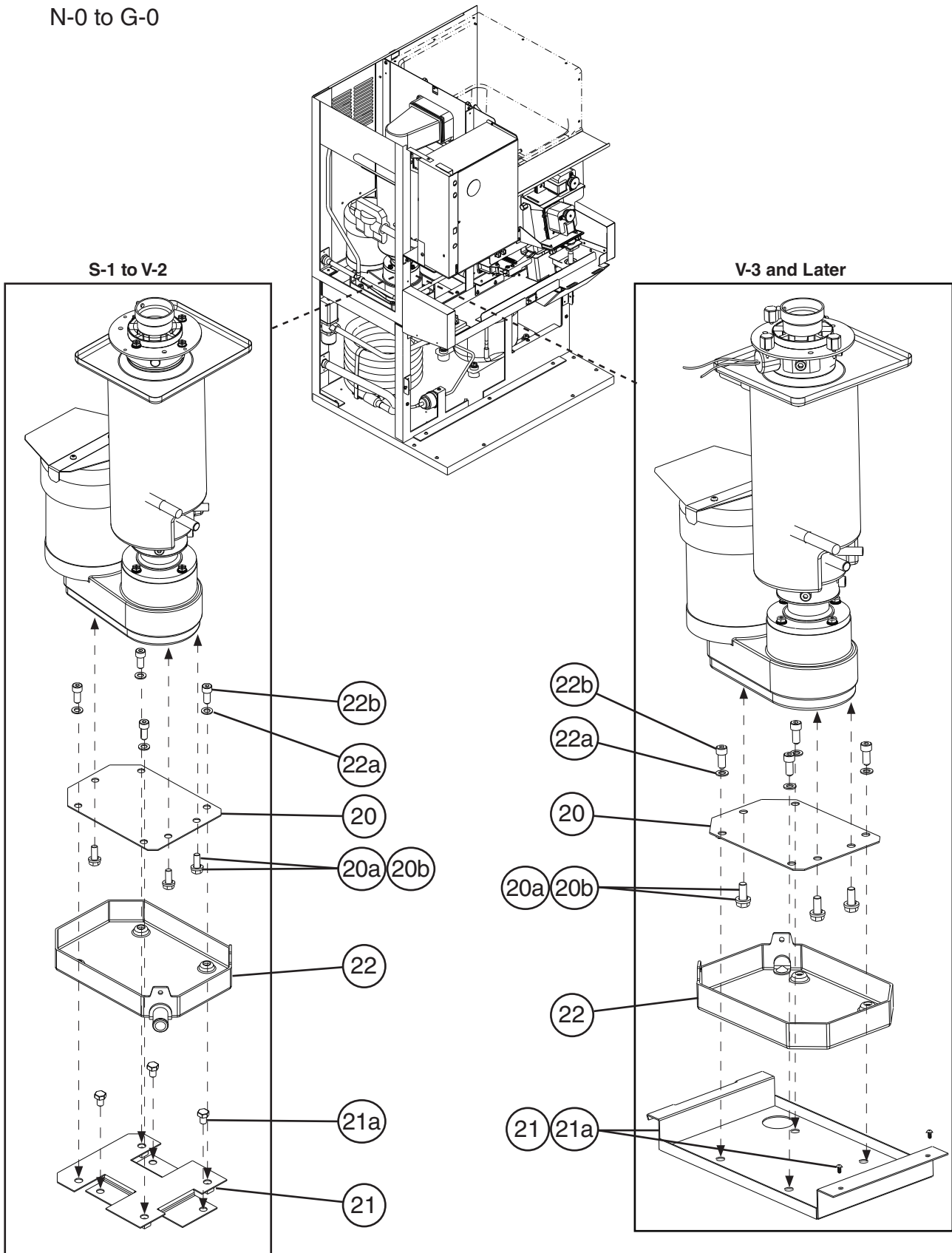



**Title: A. Main Assembly Model: DCM-500BWH-OS**

Index No.	Description	Material or Model Number	Part Number	Required Number								
				N-0 to S-0	S-1 to U-0	U-1 to V-2	V-3 to G-0					
1	Front Panel		3A2853G01	1	1	-						
			2A2891-01			1	1					
2	Top Panel		3A2514G01	1	1	1	1					
3	Right Side Panel		2A2625-01	1	1	-						
			2A6141-01			1	1					
4	Left Side Panel		2A2624-01	1	1	-						
			2A6142-01			1	1					
5	Middle Panel (Lo)		2A0699G01	1	1	1	1					
6	Control Box Cover		4A5054-01	1	1	1	1					
7	Bin Cover		2A0880A02	1	1	1	1					
7a	Thumbscrew		415949G12	4	4	4	4					
7b	Bin Cover Gasket		318984G01	1	1	1	1					
8	Ice Chute		4A2204-01	1	1	1	1					
8a	Thumbscrew		415949G08	2	2	2	2					
9	Cup Guide		326702-01	2	2	2	2					
10	Grille		2A0827G01	1	1	1	1					
11	Drip Tray		2A2591G01	1	1	1	1					
12	Spout (B)		208807-01	1	1	1	1					
12a	Thumbscrew		415949G11	4	4	4	4					
13	Spout		103329G01	1	1	1	1					
13a	Thumbscrew		415949G11	3	3	3	3					
14	Packing (A) Spout		427195-01	1	1	1	1					
15	Packing (B) Spout		427196-01	1	1	1	1					
16	Spout Cover		215773-01	1	1	1	1					
16a	Thumbscrew		415949G08	2	2	2	2					
17	Gasket		429758-01	2	2	2	2					
18	Dispense Auger		339192G01	1	1	1	1					
19	Agitator		3A0895G01	1	1	1	1					
20	Gear Motor Bracket		4A4308-01			1	3					
20a	Hex Head Bolt	8x12, SS	7B02-0812			3	3					
20b	Split Lock Washer	M8, SS	7L22-0800			3	3					
21	Drain Pan Bracket		4A4315G01			1	-					
			2A5389G01				1					
21a	Hex Head Bolt	8x12, SS	7B02-0812			3	-					
	FT Screw	4x8, SS	7F32-0408				4					
22	Drain Pan		323765G02	1	-							
			4A4354G01		1	1	-					
			4A4354G02				1					
22a	Flat Washer	M8, SS	7W22-0800			4	4					
22b	Allen Head Cap Screw	8x20, SS	7S12-0820			4	4					

**B. Refrigeration Circuit**  
**DCM-500BAH-OS**  
M-0 to G-0

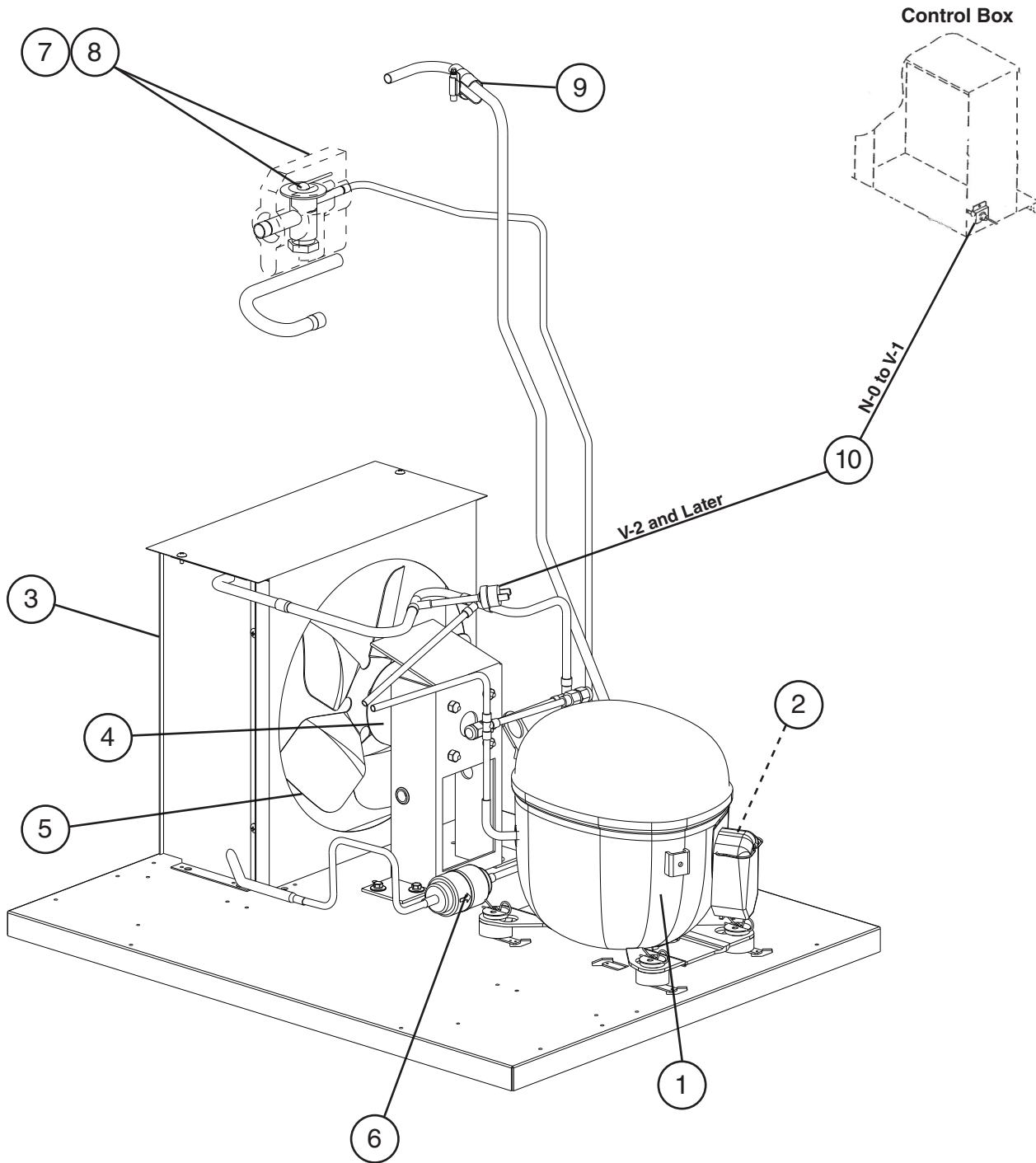

Title: B. Refrigeration Circuit Model: DCM-500BAH-OS											
Index No.	Description	Material or Model Number	Part Number	Required Number							
				M-0 to V-0	V-2 to G-0						
1	Compressor		4A2300-01	1	-						
			4A4479-01		1						
2	External Compressor Protector		4A1805-01	1	-						
			4A4481-01		1						
3	Condenser		210104-02	1	1						
4	Fan Motor		4A3158-01	1	1						
5	Fan Blade		444898-01	1	1						
6	Drier		4A1113-01	1	1						
7	Thermostatic Expansion Valve		4A1117-01	1	1						
8	Thermostatic Expansion Valve Cover		4A1168-01	1	1						
9	Thermostatic Expansion Valve Bulb Holder		3A0107-01	1	1						
10	High-Pressure Switch		433441-07	1	-						
			463180-04		1						

**B. Refrigeration Circuit**  
**DCM-500BWH-OS**  
N-0 to G-0

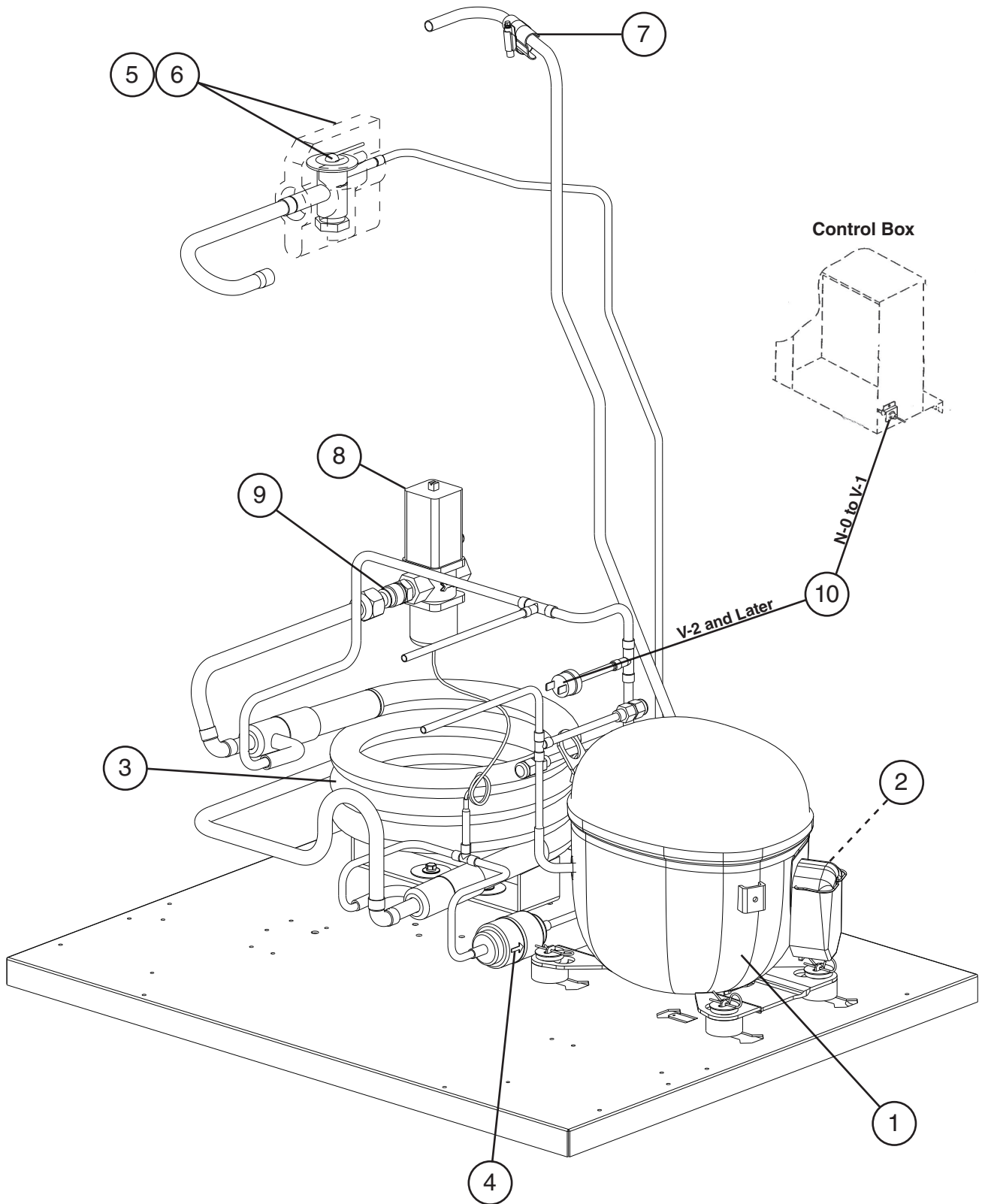

Title: B. Refrigeration Circuit Model: DCM-500BWH-OS											
Index No.	Description	Material or Model Number	Part Number	Required Number							
				N-0 to V-0	V-2 to C-0	C-1 to G-0					
1	Compressor		4A2300-01	1	-						
			4A4479-01		1	1					
2	External Compressor Protector		4A1805-01	1	-						
			4A4481-01		1	1					
3	Condenser	HS-5098	2A2359G02	1	1	-					
			3A7321-01			1					
4	Drier		4A1113-01	1	1	1					
5	Thermostatic Expansion Valve		4A1117-01	1	1	1					
6	Thermostatic Expansion Valve Cover		4A1168-01	1	1	1					
7	Thermostatic Expansion Valve Bulb Holder		3A0107-01	1	1	1					
8	Water Regulating Valve		4A0911-04	1	1	1					
9	Male Connector		4A1087-01	1	1	1					
10	High-Pressure Switch		433441-05	1	-						
			463180-05		1	1					

**C. Icemaking Unit**  
**DCM-500B\_H-OS**  
T-0 to G-0

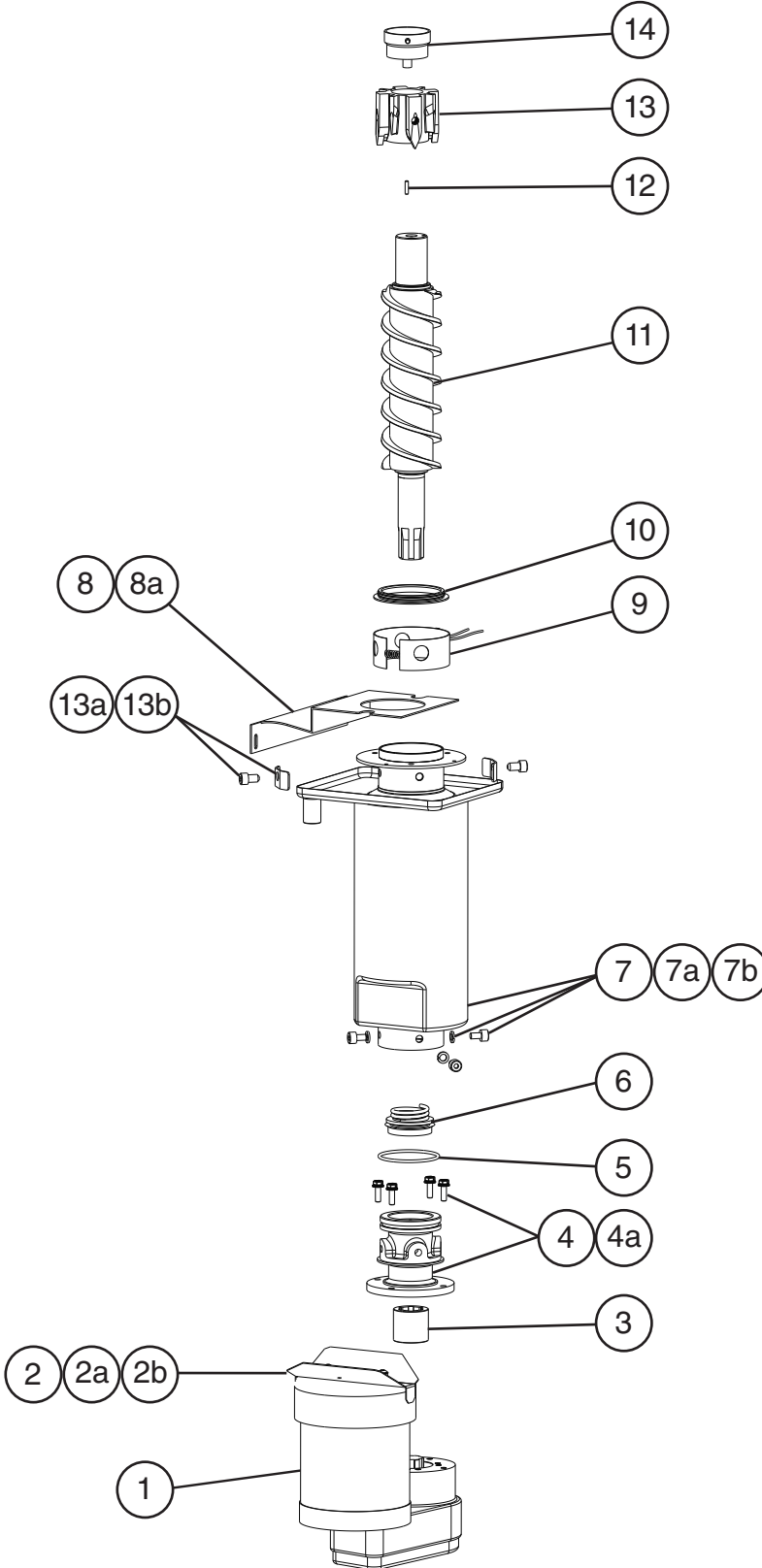

Title: C. Icemaking Unit Model: DCM-500B_H-OS											
Index No.	Description	Material or Model Number	Part Number	Required Number							
				M-0 to S-0	S-1 to F-0	F-1 to G-0					
1	Gear Motor		HS-2125	1	-						
			4A4320-01		1	-					
			4A5650-01			1					
2	Gear Motor Cover		3A4584-01	1	1	1					
2a	Truss Head Screw	5x8	7C32-0508	2	2	2					
2b	Rubber Seal Washer		4A5268-02	2	2	2					
3	Spline Coupling		4A3204-01	1	1	1					
4	Housing		2A0947G01	1	1	1					
4a	Bolt		4A1989-01	4	4	4					
5	O-Ring		4A4755-02	1	1	1					
6	Mechanical Seal		432492-01	1	1	1					
7	Evaporator		2A3314G01	1	1	1					
7a	Split Lock Washer	M8, SS	7L22-0800	4	4	4					
7b	Allen Head Cap Screw	8x12, SS	7S12-0812	4	4	4					
8	Evaporator Bracket		3A0360-01	1	1	1					
8a	Hex Head Bolt w/ Washer	5x10, SS	7B0230510	2	2	2					
9	Evaporator Heater		4A2292-01		1	1					
10	Packing		427151-02	1	1	1					
11	Auger		120863G02	1	1	1					
12	Dowel Pin		713S-0416	1	1	1					
13	Extruding Head		216530G04	1	1	1					
13a	Washer		427184-01	1	1	1					
13b	Seal Bolt		P01768-01	4	4	4					
14	Cutter		427183G01	1	1	1					





Title: D. Water Circuit Model: DCM-500B_H-OS										
Index No.	Description	Material or Model Number	Part Number	Required Number						
				M-0 to P-1	Q-0 to S-0	S-1 to V-2	V-3 to B-0 (D)	B-0 (E) to G-0		
1	Water Supply Pipe		2A0680G01	1	1	1	1	-		
			2A7569G01					1		
2	Washer		4A0867-01	2	2	2	2	-		
	Rubber Gasket		413854-03					2		
3	Water Valve (Inlet and Dispense)		4A0865-01	2	2	2	2	-		
			4A5309-01					2		
4	Water Valve (Drain)		4A2772-01	1	1	1	1	1		
5	Reservoir		2A0753-01	1	1	1	1	1		
6	Reservoir Cover		214810-01	1	1	1	1	1		
7	Reservoir Inlet (inlet water valve)		4A0869-01	1	1	1	1	1		
8	Reservoir Inlet (drain valve)		4A0869-01	1	1	1	-	1		
	Vinyl Hose (drain valve)	L=75 mm	7725-0912				1	-		
9	Float Switch		435490-01	1	1	1	1	1		
10	Reservoir Separator		4A1255-01	1	1	1	1	1		
11	Reservoir Hose		4A1165-02	1	1	1	1	1		
12	Tee		4A3615-01	1	1	1	1	1		
13	Tee		4A0525-04	1	1	1	1	1		
14	Elbow		4A1017-01	1	1	1	1	1		
15	Elbow		4A1016-01	1	1	1	1	1		
16	Silicone Hose	L=310 mm	773013896	1	1	1	-			
		L=300 mm					1	1		
17	Vinyl Hose	L=70 mm	7716-2025	2	2	2	-			
		L=60 mm					3	3		
18	Vinyl Hose	L=100 mm	7716-2025				1	1		
19	Vinyl Hose	L=320 mm	7725-1923	1	1	1	-			
		L=225 mm					1	-		
		L=290 mm						1		
20	Vinyl Hose	L=400 mm	7725-1923					1		
21	Vinyl Hose	L=225 mm	7725-1923					1		
22	Vinyl Hose	L=250 mm	4A0658L01	1	1	1	-			
		L=225 mm					1	1		
23	Vinyl Hose	L=345 mm	4A0658L01	1	1	1	1	1		
24	Drain Fitting		4A0776G01	2	2	2	2	-		
			4A5527-01					2		
<b>Hose Clamps</b>										
	Hose Clamp	21-26 mm	4A2017-01	10	10	10	-			
	Hose Clamp	26-30 mm	4A2017-02	2	2	2	-			
	Hose Clamp	31-36 mm	4A2017-03	4	4	4	-			
	Hose Clamp	17-20 mm	4A2017-05	1	1	1	1	1		
	Hose Clamp	19-22 mm	4A2017-06	1	1	1	-			
	Hose Clamp	13-15 mm	4A2017-08	4	4	4	3	3		

**E. Control Box Assembly**  
**DCM-500B\_H-OS**  
 M-0 to G-0

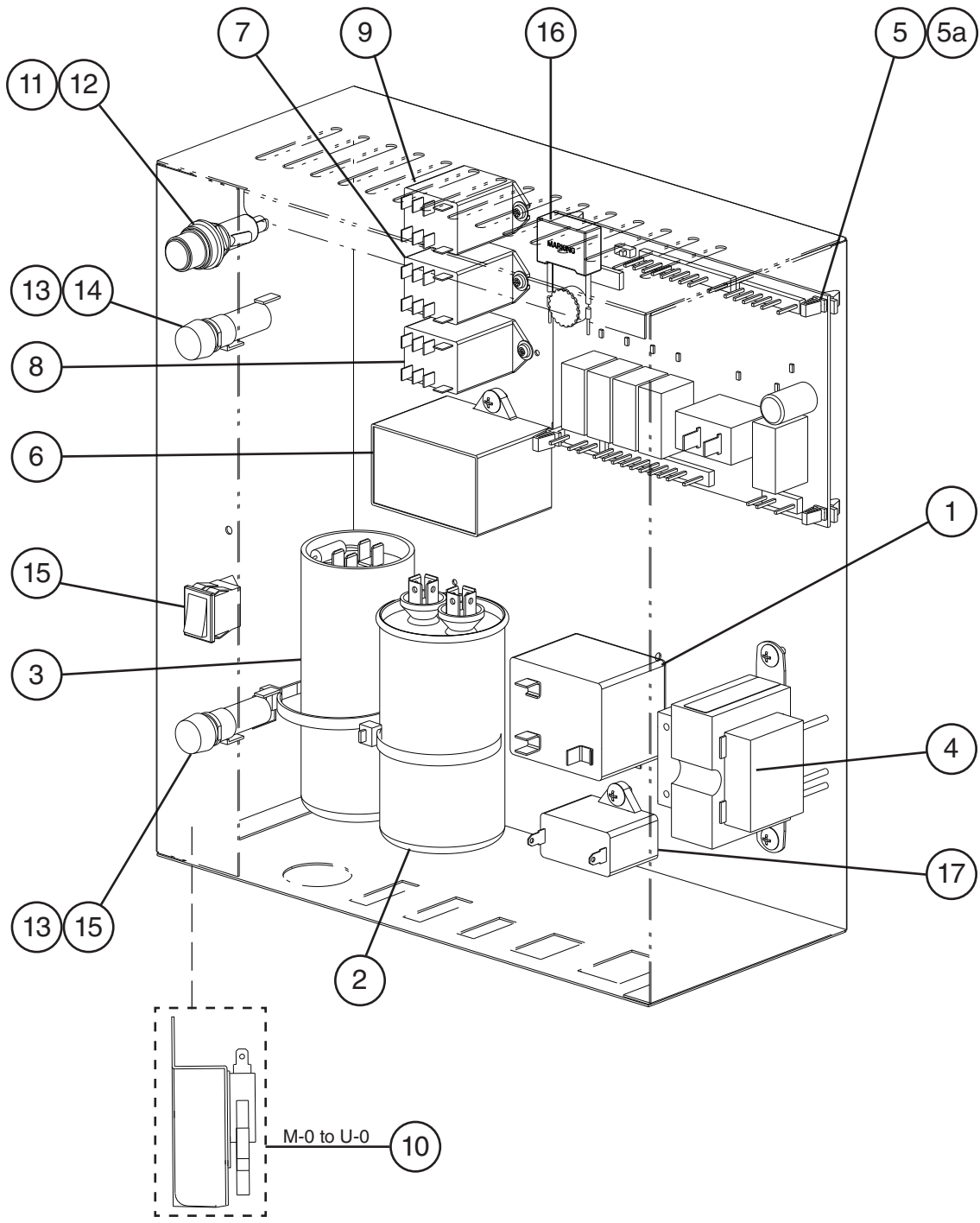

Title: E. Control Box Assembly Model: DCM-500B_H-OS												
Index No.	Description	Material or Model Number	Part Number	Required Number								
				M-0 to Q-1	R-0 S-0	S-1 to U-0	U-1 to V-0	V-2	V-3 to V-5	A-0 to G-0		
1	Start Relay		4A1107-11	1	1	1	1	1	1	1		
2	Run Capacitor	15MFD, 370VAC	3A2005-08	1	1	1	1	-				
		35MFD, 440VAC	3A2005-12					1	1	1		
3	Start Capacitor	243-292MFD, 115VAC	3A0076-10	1	1	1	1	-				
		243-292MFD, 165VAC	3A0076-20					1	1	1		
4	Control Transformer		3A6652-01	1	1	1	1	1	1	1		
5	Control Board		2A2649-01	1	1	1	1	1	1	1		
5a	Control Board Support		4A0336-03	4	4	4	4	4	4	4		
6	Gear Motor Capacitor	12MFD, 330VAC	4A0894-01	1	1	-						
		20MFD, 350VAC	4A4319-01			1	1	1	1	1		
7	Gear Motor Relay	120VAC	406132-07	1	1	1	1	1	1	1		
8	Power Protect Relay	220/240VAC	418271-05	1	1	1	1	1	1	1		
9	Water Control Relay	24VAC	406132-03	1	1	1	1	1	1	1		
10	Microswitch		4A2546-01	1	1	1	-					
11	Fuse Holder		4A0892-01	1	1	1	1	1	1	-		
			4A5443-01								1	
12	Fuse	AGC-1A, 250VAC	4A0893-01	1	1	1	1	1	1	1		
13	Fuse Holder		4A3449-02	2	2	2	2	2	2	2		
14	Fuse	GMC-500mA, 250VAC	4A0893-02	1	1	1	1	1	1	1		
15	Fuse	GMD-1.5A, 250VAC	4A0893-04	1	-							
		GMD-1.6A, 250VAC	4A0893-08		1	-						
		GMD-2.0A, 250VAC	4A0893-05			1	1	1	1	1	1	
16	Rocker Switch (power)		4A0558-01	1	1	1	1	1	1	1		
17	R-C Capacitor		4A1012-01	1	1	1	1	1	1	1		
18	Fan Motor Capacitor	<b>DCM-500BAH-OS</b> 5MFD, 250VAC	443192-02	1	1	1	1	1	1	1		

**F. Apron Panel Assembly**  
**DCM-500B\_H-OS**  
M-0 to G-0

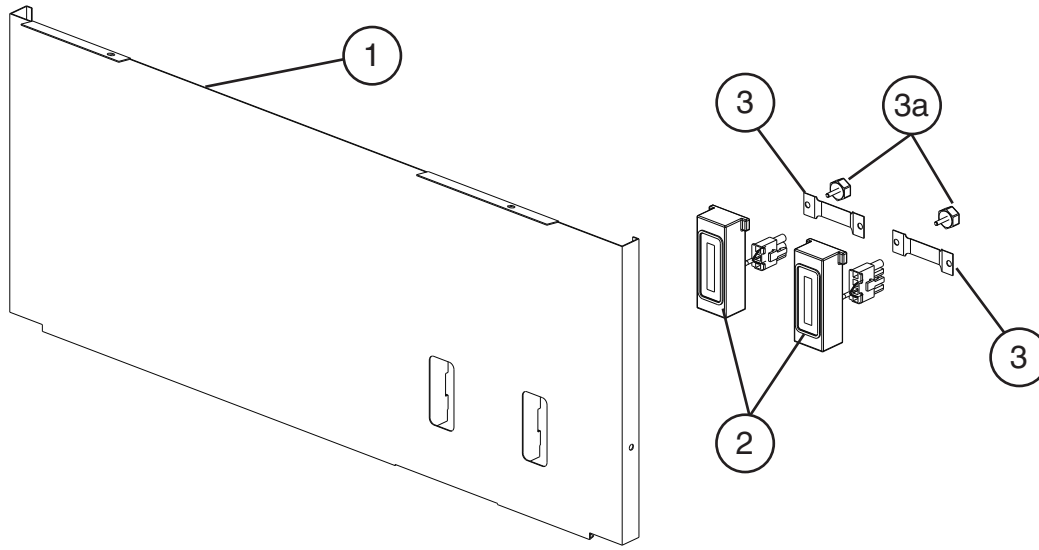

Title: F. Apron Panel Assembly Model: DCM-500B_H-OS											
Index No.	Description	Material or Model Number	Part Number	Required Number							
				M-0 to P-1	Q-0 to G-0						
1	Apron Panel		3A2494G01	1	-						
			3A3617G01		1						
2	Sensor Assembly	<b>Ice</b> 3-prong plug	4A3753G01	1	1						
		<b>Water</b> 4-prong plug	4A3753G02	1	1						
3	Sensor Cover		4A3848-01		2						
3a	Thumbscrew		415949G10		2						

## G. Middle Front Frame Assembly

### DCM-500B\_H-OS

M-0 to G-0

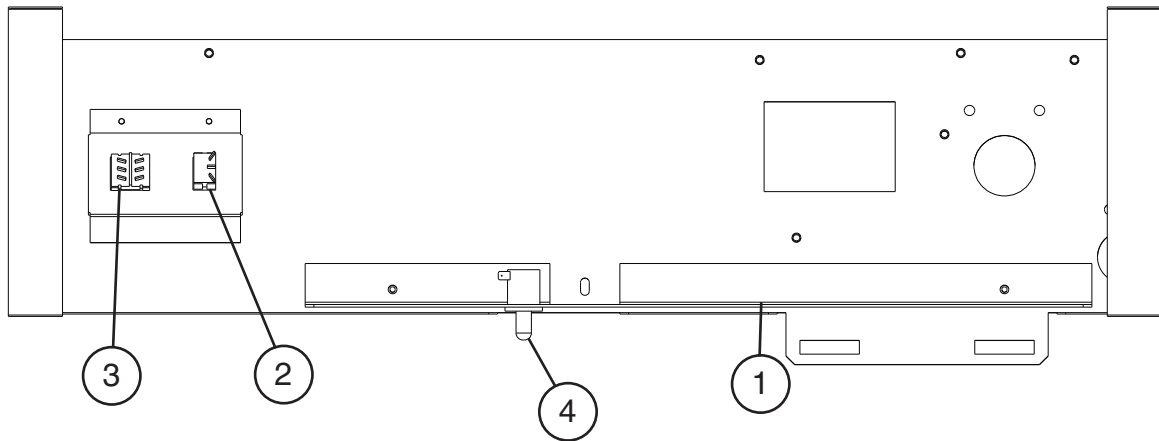

Title: G. Middle Front Frame Assembly Model: DCM-500B_H-OS										
Index No.	Description	Material or Model Number	Part Number	Required Number						
				M-0 to U-0	U-1 to G-0					
1	Middle Front Frame		2A2743G01	1	1					
2	Rocker Switch (dispense)		4A2957-01	1	1					
3	Rocker Switch (control)		4A1034-01	1	1					
4	Safety Switch (plunger)		4A5034-01		1					

# H. Shutter Assembly

## DCM-500B\_H-OS

1/2  
M-0 to A-0

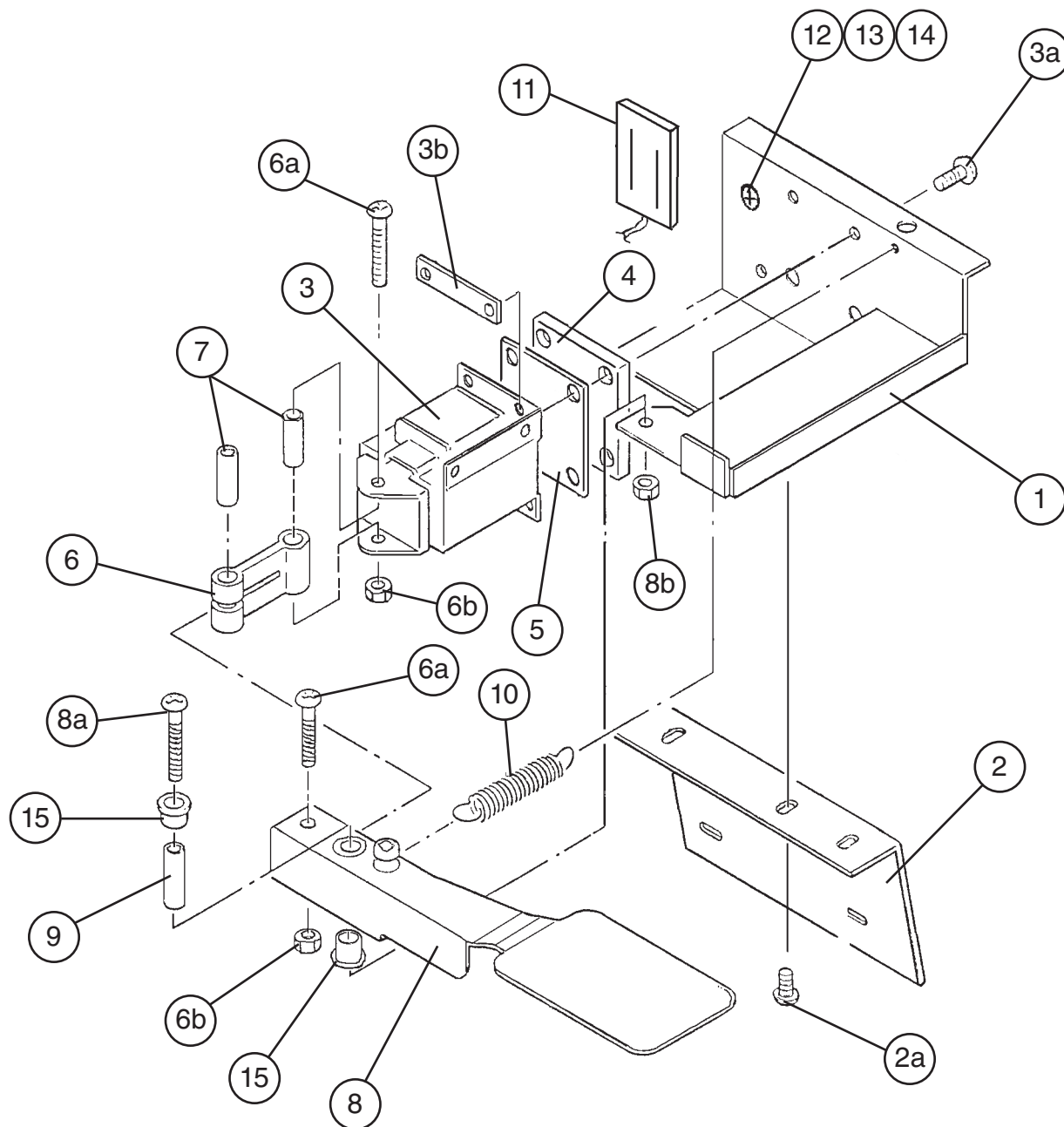

**H. Shutter Assembly**  
**DCM-500B\_H-OS**  
**2/2**  
A-1 to G-0

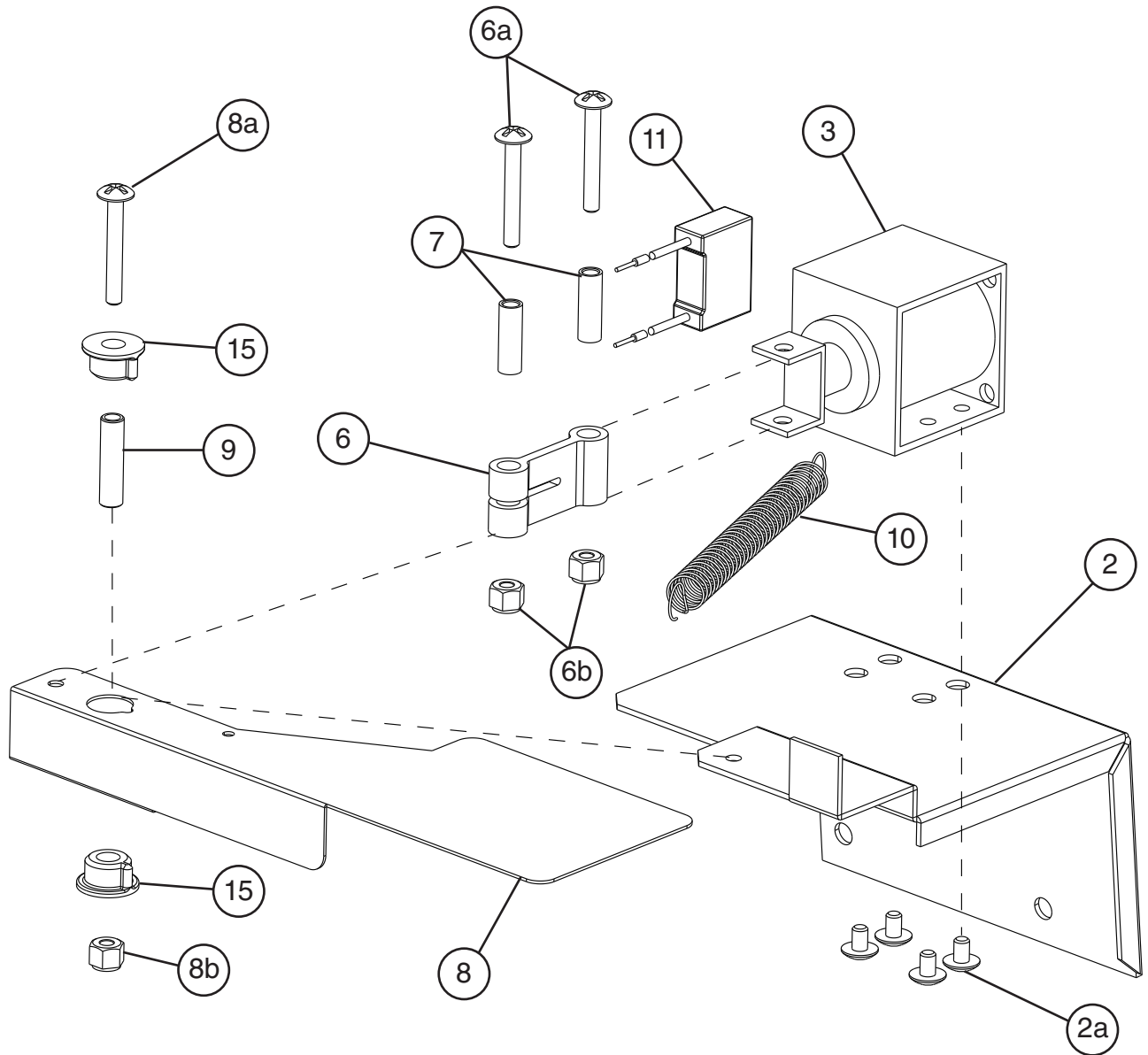

Title: H. Shutter Assembly Model: DCM-500_H-OS											
Index No.	Description	Material or Model Number	Part Number	Required Number							
				M-0 to A-0	A-1 to G-0						
1	Shutter Base		3A1817-01	1	-						
2	Shutter Base (B)		3A1762-01	1	-						
			3A6138-01		1						
2a	Truss Head Screw	4x8	7C32-0408	2	-						
		4x6	7C32-0406		4						
3	Solenoid		3U0095-01	1	-						
			4A0856-01		1						
3a	Truss Head Screw	4x12	7C32-0412	4	-						
3b	Solenoid Nut		429723-01	2	-						
4	Solenoid Packing		430380-01	1	-						
5	Packing Cover		431623-01	1	-						
6	Link		432232-01	1	1						
6a	Truss Head Screw	4x30	7C32-0430	2	2						
6b	Self-Locking "U" Nut	M4	7N22-0400	2	2						
7	Collar (D)		432471-01	2	2						
8	Lever		3A1653G01	1	-						
			3A6139-01		1						
8a	Truss Head Screw	4x30	7C32-0430	1	1						
8b	Self-Locking "U" Nut	M4	7N22-0400	1	1						
9	Collar (E)		432240-02	1	1						
10	Spring		432878-01	1	1						
11	R-C Capacitor		4A1012-01	1	1						
12	Truss Head Screw (GND)	4x8	7C32-0408	2	-						
13	Hex Nut	M4	7N12-0400	1	-						
14	Tooth Washer	M4	7R22-0400	1	-						
15	Plastic Sleeve Insert		432235-01	2	-						
			435533-01		2						



**J. Gear Motor Assembly (Agitator)**  
**DCM-500B\_H-OS**  
M-0 to G-0

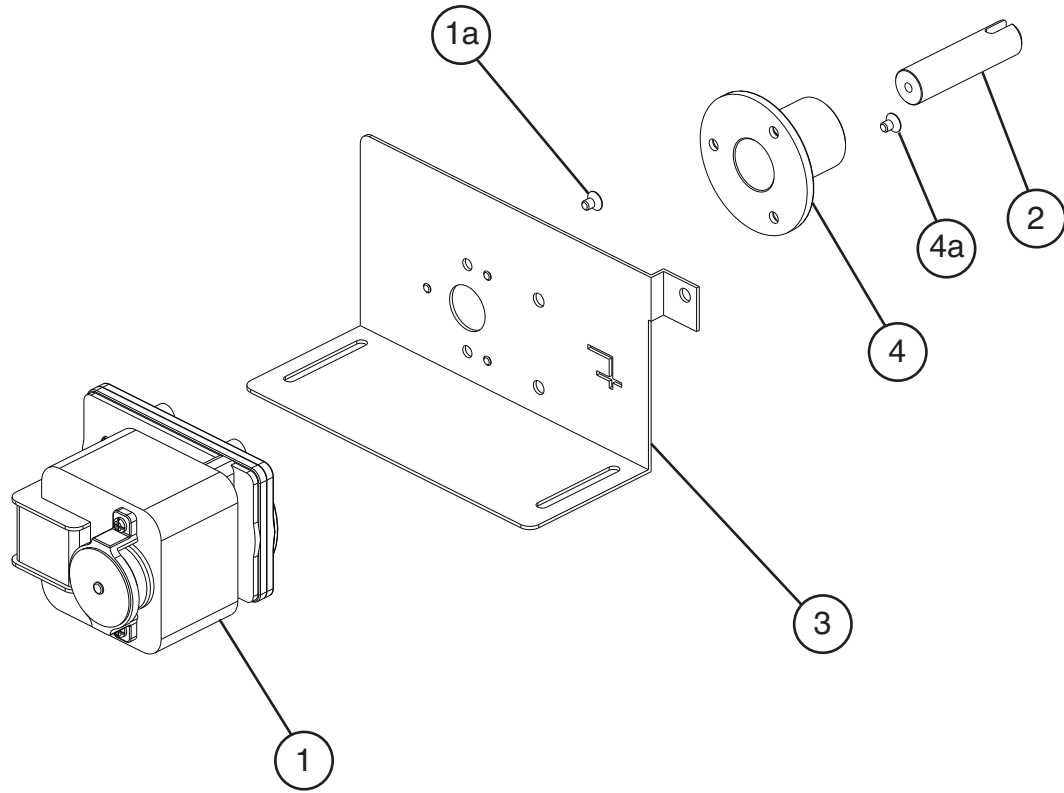

Title: J. Gear Motor Assembly (Agitator) Model: DCM-500B_H-OS					Required Number						
Index No.	Description	Material or Model Number	Part Number	M-0 to G-0							
1	Gear Motor		3A6786-01	1							
1a	Flat Head Screw	4x8, SS	7C22-0408	4							
2	Joint		429764-01	1							
3	Gear Motor Bracket (B1)		4A0618-01	1							
4	Plastic Sleeve (A)		429761-01	1							
4a	Flat Head Screw	4x8, SS	7C22-0408	3							

# K. Gear Motor Assembly (Dispense)

## DCM-500B\_H-OS

M-0 to G-0

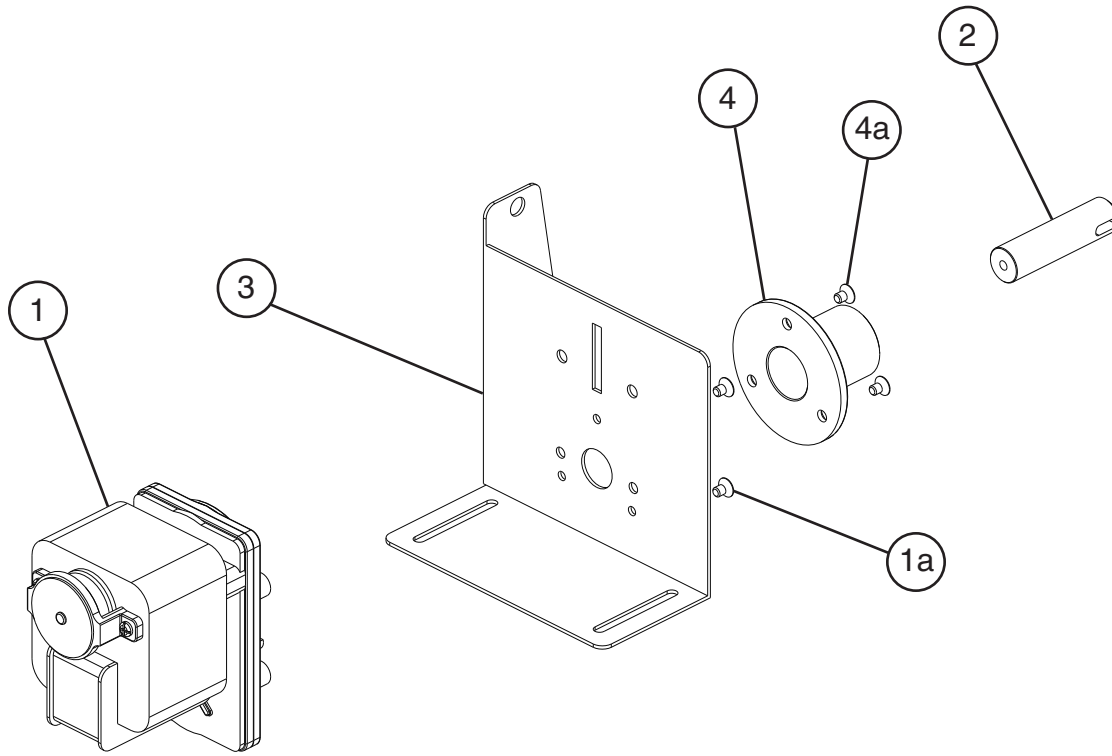

Title: K. Gear Motor Assembly (Dispense) Model: DCM-500B_H-OS					Required Number								
Index No.	Description	Material or Model Number	Part Number	M-0 to G-0									
1	Gear Motor		3A6786-02	1									
1a	Flat Head Screw	4x8, SS	7C22-0408	4									
2	Joint		429764-01	1									
3	Gear Motor Bracket (A3)		3A0361-01	1									
4	Plastic Sleeve (A)		429761-01	1									
4a	Flat Head Screw	4x8, SS	7C22-0408	3									

**L. Bin Assembly**  
**DCM-500B\_H-OS**  
M-0 to G-0

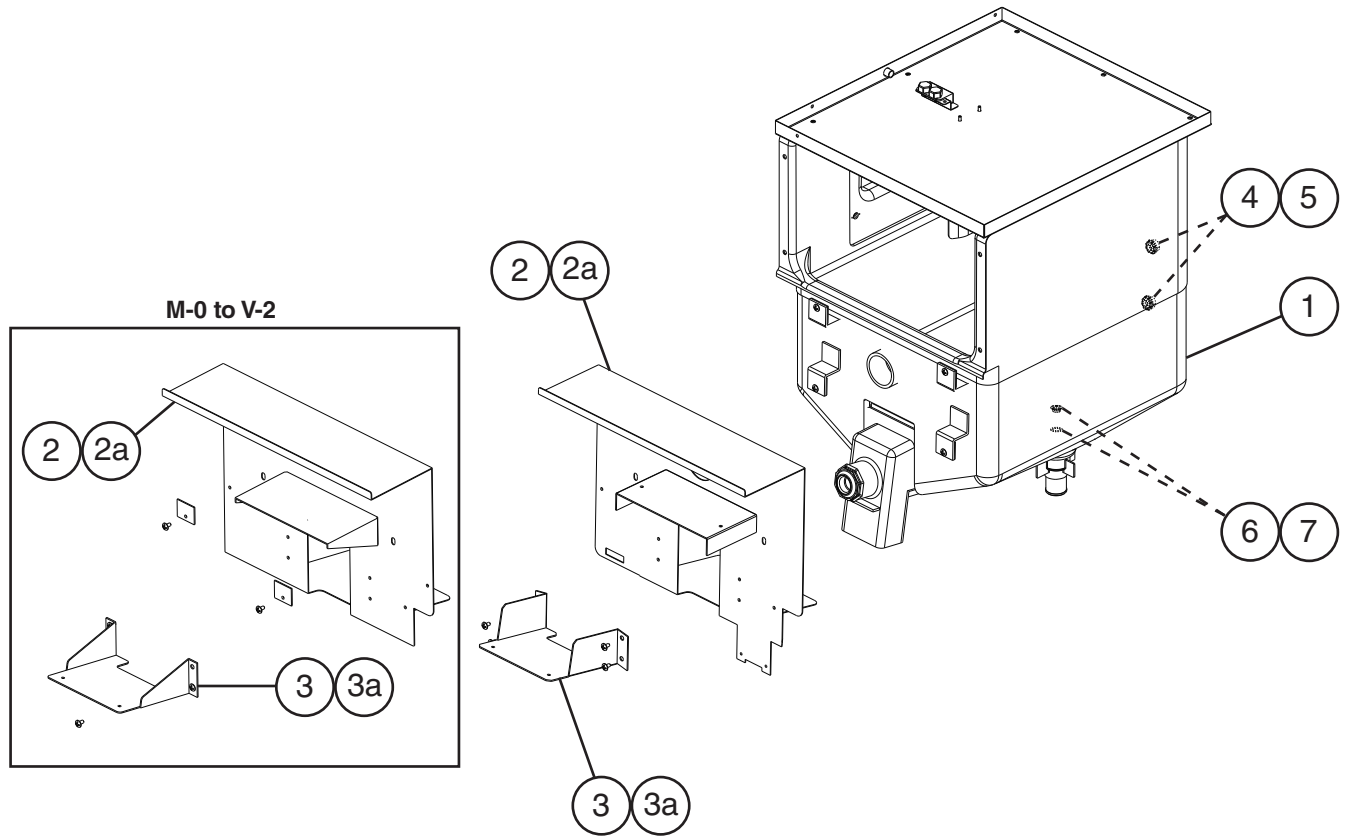

Title: L. Bin Assembly		Model: DCM-500B_H-OS		Required Number								
Index No.	Description	Material or Model Number	Part Number	M-0 to V-2	V-3 to D-0	E-0 to G-0						
1	Foamed Bin		103687G01	1	1	1						
2	Barrier		2A2008G01	1	-							
			2A5487G01		1	-						
			2A7679G01				1					
2a	Truss Head Screw	4x8 SS	7C32-0408	3	3	3						
3	Sliding Bracket		3A0364-01	1	1	1						
3a	Truss Head Screw	4x8, SS	7C32-0408	4	4	4						
4	Shaft Holder (C)		429818-01	2	2	2						
5	O-Ring		7616-P032	2	2	2						
6	Drain Cap		418294-01	1	1	1						
7	Rubber Packing (B)		413857-02	1	1	1						

**M. Bin Top Assembly**  
**DCM-500B\_H-OS**  
 M-0 to G-0

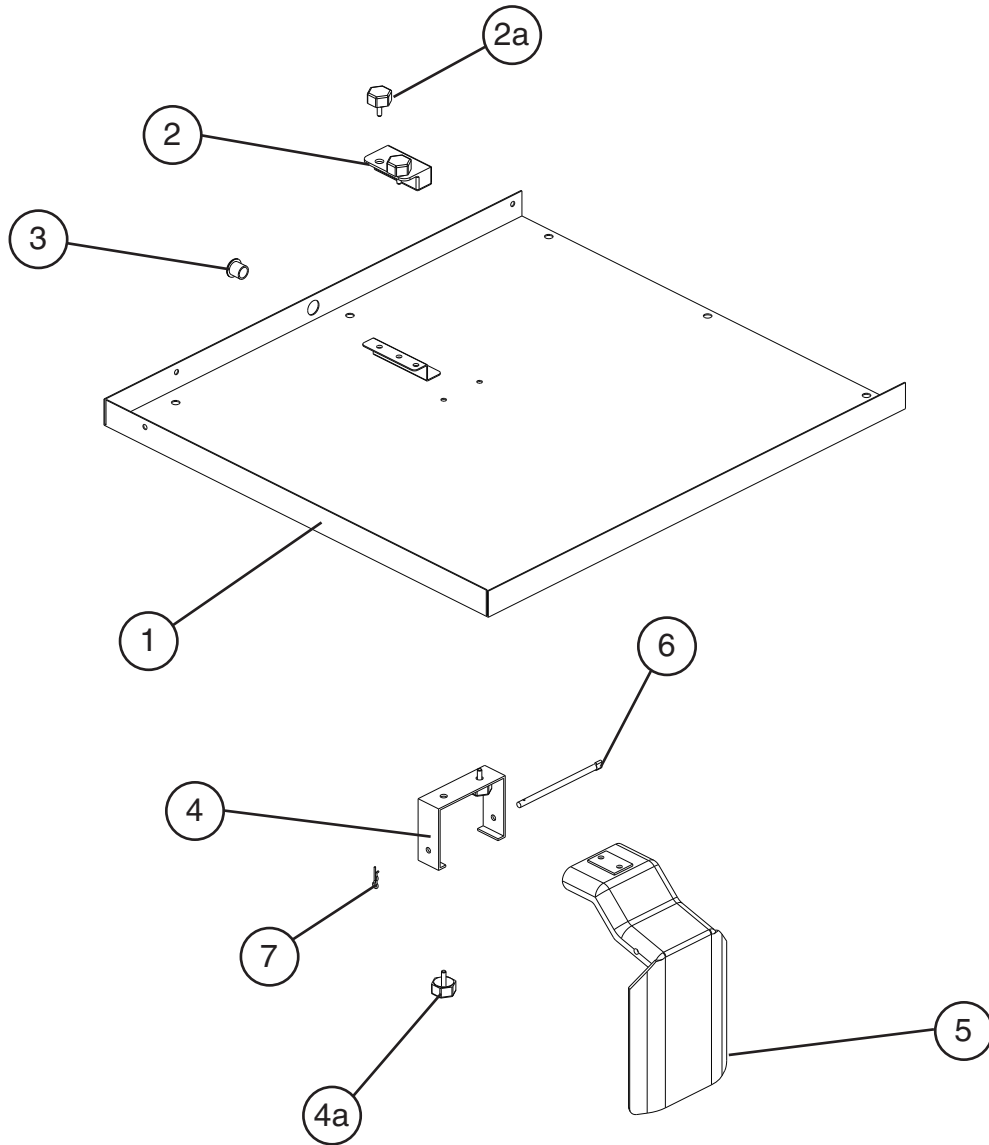

Title: M. Bin Top Assembly    Model: DCM-500B_H-OS					Required Number								
Index No.	Description	Material or Model Number	Part Number	M-0 to G-0									
1	Bin Top Cover		2A1716G01	1									
2	Proximity Switch		4A2033-01	1									
2a	Thumbscrew		415949G08	2									
3	Bushing		420470-07	1									
4	Hinge		3A0762-01	1									
4a	Thumbscrew		415949G08	2									
5	Actuator		208795G01	1									
6	Shaft		412337-03	1									
7	Snap Pin		715S-0004	1									

**N. Accessories & Labels**  
**DCM-500B\_H-OS**  
M-0 to G-0

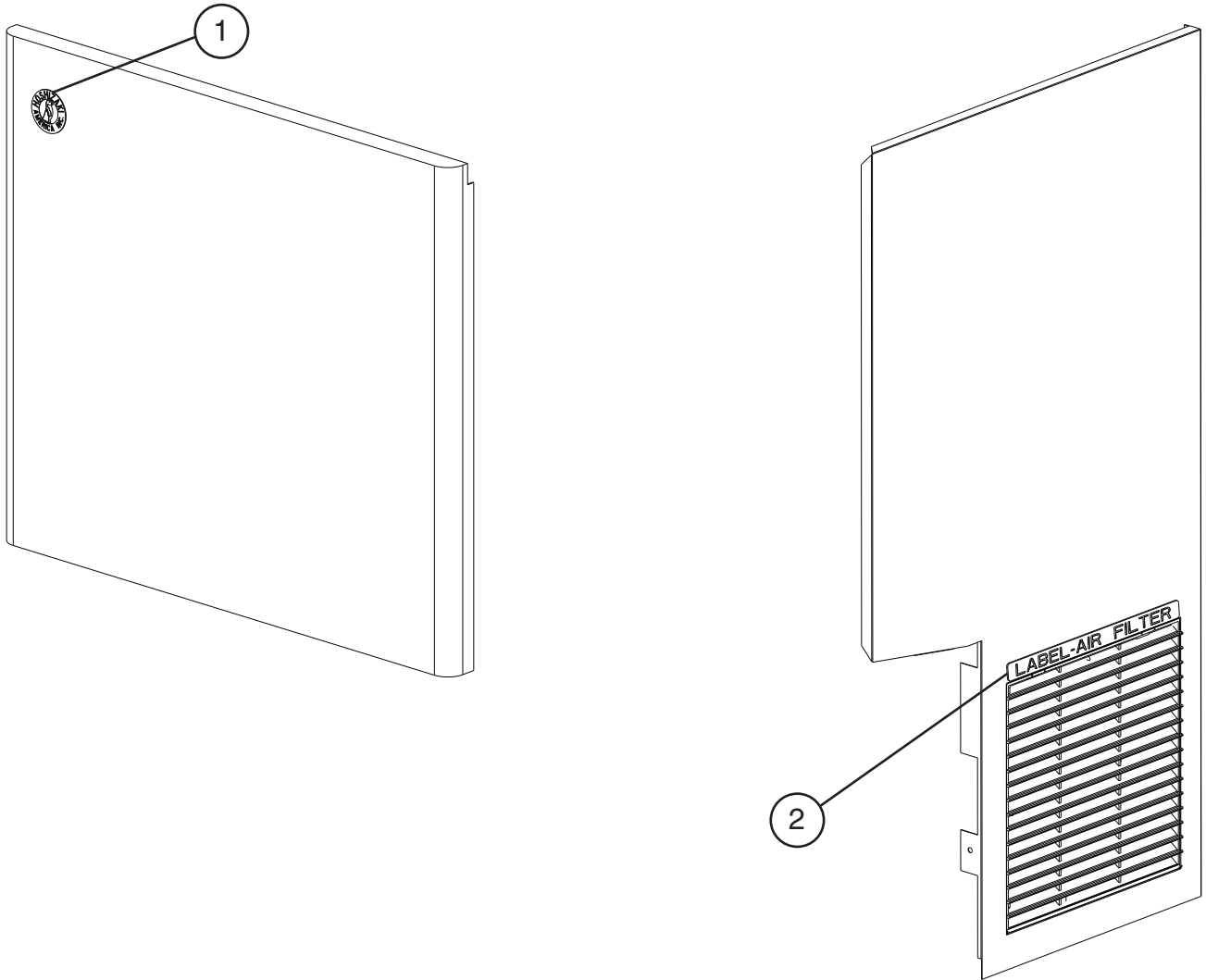

Title: N. Accessories & Labels    Model: DCM-500B_H-OS												
Index No.	Description	Material or Model Number	Part Number	Required Number								
				M-0 to G-0								
1	Label Penguin-HA-R		456246-01	1								
2	Label-Air Filter	<b>DCM-500BAH-OS</b>	426177-01	1								