

NO:	73097
ISSUED:	NOV. 8, 2000
REVISED:	DEC. 22, 2003



**HOSHIZAKI  
MODULAR FLAKER**

**MODEL**

**F-1001MAF/-C**

**F-1001MWF/-C**

**F-1001MRF/-C**

**F-1001MLF/-C**

**SERVICE MANUAL**

## **IMPORTANT**

Only qualified service technicians should attempt to service or maintain this icemaker. No service or maintenance should be undertaken until the technician has thoroughly read this Service Manual.

HOSHIZAKI provides this manual primarily to assist qualified service technicians in the service and maintenance of the icemaker.

Should the reader have any questions or concerns which have not been satisfactorily addressed, please call or write to the HOSHIZAKI Technical Support Department for assistance.

HOSHIZAKI AMERICA, INC.  
618 Highway 74 South  
Peachtree City, GA 30269

Attn: HOSHIZAKI Technical Support Department

Phone: 1-800-233-1940 Technical Service  
(770) 487-2331  
Fax: (770) 487-3360

**NOTE:** To expedite assistance, all correspondence/communication **MUST** include the following information:

- Model Number
- Serial Number
- Complete and detailed explanation of the problem

Please review this manual. It should be read carefully before the icemaker is serviced or maintenance operations are performed. Only qualified service technicians should service and maintain the icemaker. This manual should be made available to the technician prior to service or maintenance.

## CONTENTS

	PAGE
I. SPECIFICATIONS .....	5
1. ICEMAKER .....	5
F-1001MAF .....	5
F-1001MWF .....	6
F-1001MRF .....	7
F-1001MLF .....	8
F-1001MAF-C .....	9
F-1001MWF-C .....	10
F-1001MRF-C .....	11
F-1001MLF-C .....	12
2. CONDENSER UNIT .....	13
URC-6F .....	13
II. GENERAL INFORMATION .....	15
1. CONSTRUCTION .....	15
F-1001MAF/-C .....	15
F-1001MWF/-C .....	16
F-1001MRF/-C .....	17
F-1001MLF/-C .....	18
2. CONTROL BOX LAYOUT .....	19
F-1001MAF/-C .....	19
F-1001MWF/-C, F-1001MRF/-C .....	20
F-1001MLF/-C .....	21
III. TECHNICAL INFORMATION .....	22
1. WATER CIRCUIT AND REFRIGERANT CIRCUIT .....	22
F-1001MAF/-C .....	22
F-1001MWF/-C .....	23
F-1001MRF/-C .....	24
F-1001MLF/-C .....	25
2. WIRING DIAGRAM .....	26
F-1001MAF/-C, F-1001MWF/-C, F-1001MRF/-C .....	26
F-1001MLF/-C .....	27
3. SEQUENCE OF ELECTRICAL CIRCUIT .....	28
4. TIMING CHART .....	38
5. PERFORMANCE DATA .....	41
F-1001MAF .....	41

F-1001MWF .....	42
F-1001MRF .....	43
F-1001MLF .....	44
F-1001MAF-C .....	45
F-1001MWF-C .....	46
F-1001MRF-C .....	47
F-1001MLF-C .....	48
IV. ADJUSTMENT OF COMPONENTS .....	49
1. ADJUSTMENT OF WATER REGULATING VALVE	
- WATER-COOLED MODEL ONLY .....	49
V. SERVICE DIAGNOSIS .....	50
1. NO ICE PRODUCTION .....	50
2. LOW ICE PRODUCTION .....	52
3. OTHERS .....	53
VI. REMOVAL AND REPLACEMENT OF COMPONENTS .....	54
1. SERVICE FOR REFRIGERANT LINES .....	54
[a] REFRIGERANT RECOVERY [EXCEPT F-1001MLF/-C] .....	54
[b] REFRIGERANT RECOVERY [F-1001MLF ONLY] .....	54
[c] EVACUATION AND RECHARGE .....	54
2. BRAZING .....	55
3. REMOVAL AND REPLACEMENT OF COMPRESSOR .....	56
4. REMOVAL AND REPLACEMENT OF DRIER .....	57
5. REMOVAL AND REPLACEMENT OF EXPANSION VALVE .....	58
6. REMOVAL AND REPLACEMENT OF WATER REGULATING VALVE	
- WATER-COOLED MODEL ONLY .....	59
7. REMOVAL AND REPLACEMENT OF CONDENSING PRESSURE	
REGULATOR (C.P.R.) - REMOTE AIR-COOLED MODEL ONLY .....	60
8. REMOVAL AND REPLACEMENT OF EVAPORATOR ASSEMBLY .....	61
9. REMOVAL AND REPLACEMENT OF FAN MOTOR .....	65
10. REMOVAL AND REPLACEMENT OF CONTROL WATER VALVE .....	65
11. REMOVAL AND REPLACEMENT OF FLUSH WATER VALVE .....	66
VII. MAINTENANCE AND CLEANING INSTRUCTIONS .....	67
1. PREPARING THE ICEMAKER FOR LONG STORAGE .....	67
2. CLEANING INSTRUCTIONS .....	69
3. MAINTENANCE .....	73

# I. SPECIFICATION

## 1. ICEMAKER

### F-1001MAF

AC SUPPLY VOLTAGE	208-230/60/1 (3 wire with neutral for 115V)		
COMPRESSOR	240 V	4.2 RLA	34 LRA
GEAR MOTOR	120 V	3 FLA	1/4 HP
FAN MOTOR	115 V	0.85FLA	1/15 HP
OTHER	120 V	0.03A	
MAXIMUM FUSE SIZE	15 A		
MAX. HACR BREAKER (USA ONLY)	15 A		
MAX. CIRC. BREAKER (CANADA ONLY)	15 A		
MINIMUM CIRCUIT AMPACITY	15 A		
APPROXIMATE ICE PRODUCTION PER 24 HR. lbs./day ( kg/day ) Reference without *marks	Ambient Temp.(°F)	WATER TEMP. (°F)	
		50	70
	70	*970 (440)	930 (422)
	80	855 (388)	820 (372)
	90	755 (342)	*740 (336)
	100	665 (301)	635 (289)
SHAPE OF ICE	Flake		
ICE QUALITY	Approx. 70%, Ice (90/70°F, Conductivity 200 µs/cm)		
APPROXIMATE STORAGE CAPACITY	N/A		
ELECTRIC & WATER CONSUMPTION	90/70°F	70/50°F	
ELECTRIC W (kWH/100 lbs.)	1755 (5.7)	1530 (3.8)	
POTABLE WATER gal./24HR (gal./100 lbs.)	89 (12)	116 (12)	
EXTERIOR DIMENSIONS (WxDxH)	22" x 27-3/8" x 25-15/16" (560 x 695 x 658mm)		
EXTERIOR FINISH	Stainless Steel, Galvanized Steel (Rear)		
WEIGHT	Net 176 lbs. ( 80 kg ), Shipping 207 lbs. ( 94 kg )		
CONNECTIONS - ELECTRIC	Permanent - Connection		
- WATER SUPPLY	Inlet 1/2" FPT		
- DRAIN	Outlet 3/4" FPT		
ICE MAKING SYSTEM	Auger type		
HARVESTING SYSTEM	Direct Driven Auger ( 1/4 HP Gear Motor )		
ICE MAKING WATER CONTROL	Float Switch		
COOLING WATER CONTROL	N/A		
BIN CONTROL SYSTEM	Mechanical Bin Control ( Proximity Sw. )		
COMPRESSOR	Hermetic, Model RS70-C1E-PFV		
CONDENSER	Air-cooled, Fin and tube type		
EVAPORATOR	Copper Tube on Cylinder		
REFRIGERANT CONTROL	Thermostatic Expansion Valve		
REFRIGERANT CHARGE	R-404A, 1 lb.12oz. (800g)		
DESIGN PRESSURE	High 427 PSIG, Low 230 PSIG		
P.C. BOARD CIRCUIT PROTECTION	High Voltage Cut-off Relay		
COMPRESSOR PROTECTION	Internal Protector		
GEAR MOTOR PROTECTION	Fuse (3A)		
REFRIGERANT CIRCUIT PROTECTION	Auto-reset High Pressure Control Switch		
LOW WATER PROTECTION	Float Switch and Timer		
ACCESSORIES -SUPPLIED	Spare Fuse		
-REQUIRED	Ice Storage Bin		
OPERATING CONDITIONS	VOLTAGE RANGE	187-253 V	
	AMBIENT TEMP.	45-100° F	
	WATER SUPPLY TEMP.	45-90° F	
	WATER SUPPLY PRESSURE	10-113 PSIG	

We reserve the right to make changes in specifications and design without prior notice.

## F-1001MWF

AC SUPPLY VOLTAGE	208-230/60/1 (3 wire with neutral for 115V)		
COMPRESSOR	240 V	4.2 RLA	34 LRA
GEAR MOTOR	120 V	3 FLA	1/4 HP
OTHER	120 V	0.03A	
MAXIMUM FUSE SIZE	15 A		
MAX. HACR BREAKER (USA ONLY)	15 A		
MAX. CIRC. BREAKER (CANADA ONLY)	15 A		
MINIMUM CIRCUIT AMPACITY	15 A		
APPROXIMATE ICE PRODUCTION PER 24 HR.	Ambient Temp.(°F)	WATER TEMP. (°F)	
lbs./day ( kg/day )		50	70
Reference without *marks	7	90	
	0	*890 (404)	855 (389)
	80	820 (372)	840 (380)
	90	770 (349)	805 (364)
	100	720 (327)	*755 (342)
			735 (334)
			*655 (297)
SHAPE OF ICE	Flake		
ICE QUALITY	A	pprox. 70%, Ice (90/70°F, Conductivity 200 µs/cm)	
APPROXIMATE STORAGE CAPACITY	N/A		
ELECTRIC & WATER CONSUMPTION	90/70°F	70/50°F	
ELECTRIC W (kWH/100 lbs.)	1248 (4.1)	1245 (3.1)	
POTABLE WATER	91 (12)	107 (12)	
WATER-COOLED CONDENSER	480 (63)	303 (34)	
gal./24HR (gal./100 lbs.)			
EXTERIOR DIMENSIONS (WxDxH)	22" x 27-3/8" x 25-15/16" (560 x 695 x 658mm)		
EXTERIOR FINISH	Stainless Steel, Galvanized Steel (Rear)		
WEIGHT	Net 176 lbs. ( 80 kg ), Shipping 207 lbs. ( 94 kg )		
CONNECTIONS - ELECTRIC	Permanent - Connection		
- WATER SUPPLY	Inlet 1/2" FPT	Cond. Inlet 1/2" FPT	
- DRAIN	Outlet 3/4" FPT	Cond. Outlet 3/8" FPT	
ICE MAKING SYSTEM	Auger type		
HARVESTING SYSTEM	Direct Driven Auger ( 1/4 HP Gear Motor )		
ICE MAKING WATER CONTROL	Float Switch		
COOLING WATER CONTROL	N/A		
BIN CONTROL SYSTEM	Mechanical Bin Control ( Proximity Sw. )		
COMPRESSOR	Hermetic, Model RS70-C1E-PFV		
CONDENSER	Water-cooled, Tube in tube type		
EVAPORATOR	Copper Tube on Cylinder		
REFRIGERANT CONTROL	Thermostatic Expansion Valve		
REFRIGERANT CHARGE	R-404A, 15oz. (425g)		
DESIGN PRESSURE	High 427 PSIG, Low 230 PSIG		
P.C. BOARD CIRCUIT PROTECTION	High Voltage Cut-off Relay		
COMPRESSOR PROTECTION	Internal Protector		
GEAR MOTOR PROTECTION	Fuse (3A)		
REFRIGERANT CIRCUIT PROTECTION	Auto-reset High Pressure Control Switch		
LOW WATER PROTECTION	Float Switch and Timer		
ACCESSORIES -SUPPLIED	Spare Fuse		
-REQUIRED	Ice Storage Bin		
OPERATING CONDITIONS	VOLTAGE RANGE	187-253 V	
	AMBIENT TEMP.	45-100° F	
	WATER SUPPLY TEMP.	45-90° F	
	WATER SUPPLY PRESSURE	10-113 PSIG	

We reserve the right to make changes in specifications and design without prior notice.

# F-1001MRF

AC SUPPLY VOLTAGE	208-230/60/1 (3 wire with neutral for 115V)		
COMPRESSOR	240 V	4.2 RLA	34 LRA
GEAR MOTOR	120 V	3 FLA	1/4 HP
FAN MOTOR REMOTE	120 V	3A	MAX
OTHER	120 V	0.03A	
MAXIMUM FUSE SIZE	15 A		
MAX. HACR BREAKER (USA ONLY)	15 A		
MAX. CIRC. BREAKER (CANADA ONLY)	15 A		
MINIMUM CIRCUIT AMPACITY	15 A		
APPROXIMATE ICE PRODUCTION PER 24 HR. lbs./day ( kg/day ) Reference without *marks	Ambient Temp.(°F)	WATER TEMP. (°F)	
		50	70
	70	*930 (422)	895 (407)
	80	835 (379)	805 (366)
	90	750 (341)	*745 (338)
	100	675 (306)	*605 (274)
SHAPE OF ICE	Flake		
ICE QUALITY	Approx. 70%, Ice (90/70°F, Conductivity 200 µs/cm)		
APPROXIMATE STORAGE CAPACITY	N/A		
ELECTRIC & WATER CONSUMPTION	90/70°F	70/50°F	
ELECTRIC W (kWH/100 lbs.)	1520 (4.9)	1570 (4.1)	
POTABLE WATER gal./24HR (gal./100 lbs.)	89 (12)	111(12)	
EXTERIOR DIMENSIONS (WxDxH)	22" x 27-3/8" x 25-15/16" (560 x 695 x 658mm)		
EXTERIOR FINISH	Stainless Steel, Galvanized Steel (Rear)		
WEIGHT	Net 176 lbs. ( 80 kg ), Shipping 207 lbs. ( 94 kg )		
CONNECTIONS - ELECTRIC	Permanent - Connection		
- WATER SUPPLY	Inlet 1/2" FPT		
- DRAIN	Outlet 3/4" FPT		
- REFRIGERATION CIRCUIT	Discharge line 1-1/16-12 UNF Fitting (#10 AEROQUIP) Liquid line 5/8-18 UNF Fitting (#6 AEROQUIP)		
ICE MAKING SYSTEM	Auger type		
HARVESTING SYSTEM	Direct Driven Auger ( 1/4 HP Gear Motor )		
ICE MAKING WATER CONTROL	Float Switch		
COOLING WATER CONTROL	N/A		
BIN CONTROL SYSTEM	Mechanical Bin Control ( Proximity Sw. )		
COMPRESSOR	Hermetic, Model RS70-C1E-PFV		
CONDENSER	Air-cooled Remote Condenser unit URC-6F Recommended		
EVAPORATOR	Copper Tube on Cylinder		
REFRIGERANT CONTROL	Thermostatic Expansion Valve		
REFRIGERANT CHARGE	Condensing Pressure Regulator on URC-6F R-404A, 4 lb.1oz. (1850g) (Ice Maker: 2 lb. 3 oz., Cond. Unit: 1 lb. 14 oz. )		
DESIGN PRESSURE	High 427 PSIG, Low 230 PSIG		
P.C. BOARD CIRCUIT PROTECTION	High Voltage Cut-off Relay		
COMPRESSOR PROTECTION	Internal Protector		
GEAR MOTOR PROTECTION	Fuse (3A)		
REFRIGERANT CIRCUIT PROTECTION	Auto-reset High Pressure Control Switch		
LOW WATER PROTECTION	Float Switch and Timer		
ACCESSORIES -SUPPLIED	Spare Fuse		
-REQUIRED	Ice Storage Bin		
OPERATING CONDITIONS	VOLTAGE RANGE	187-253 V	
	AMBIENT TEMP.	45-100° F	
	WATER SUPPLY TEMP.	45-90° F	
	WATER SUPPLY PRESSURE	10-113 PSIG	

We reserve the right to make changes in specifications and design without prior notice.

## F-1001MLF

AC SUPPLY VOLTAGE	115/60/1		
GEAR MOTOR	120 V	3 FLA	1/4 HP
OTHER	120 V	0.03A	
MAXIMUM FUSE SIZE	15 A		
MAX. HACR BREAKER (USA ONLY)	15 A		
MAX. CIRC. BREAKER (CANADA ONLY)	15 A		
MINIMUM CIRCUIT AMPACITY	15 A		
APPROXIMATE ICE PRODUCTION PER 24 HR.	Ambient Temp. (F)	WATER TEMP. (F)	
lbs./day ( kg/day )		50	70
	70	1150 (522)	1035 (469)
	80	980 (444)	950 (431)
	90	900 (408)	885 (401)
	100	830 (376)	805 (366)
		90	1005 (456)
			925 (420)
			850 (386)
			690 (313)
SHAPE OF ICE	Flake		
ICE QUALITY	Approx. 70%, Ice (90/70°F, Conductivity 200 µs/cm)		
APPROXIMATE STORAGE CAPACITY	N/A		
ELECTRIC & WATER CONSUMPTION	90/70°F	70/50°F	
ELECTRIC W (kWH/100 lbs.)	650 (1.8)	650 (1.4)	
POTABLE WATER	106 (12)	138 (12)	
gal./24HR (gal./100 lbs.)			
EXTERIOR DIMENSIONS (WxDxH)	22" x 27-3/8" x 25-15/16" (560 x 695 x 658mm)		
EXTERIOR FINISH	Stainless Steel, Galvanized Steel (Rear)		
WEIGHT	Net 114 lbs. ( 52 kg ), Shipping 146 lbs. ( 66 kg )		
CONNECTIONS - ELECTRIC	Permanent - Connection		
- WATER SUPPLY	Inlet 1/2" FPT		
- DRAIN	Outlet 3/4" FPT		
- REFRIGERATION CIRCUIT	Outlet (Vapor) line 1-1/16-12 UNF Fitting (#10 AEROQUIP) Inlet (Liquid) line 5/8-18 UNF Fitting (#6 AEROQUIP)		
ICE MAKING SYSTEM	Auger type		
HARVESTING SYSTEM	Direct Driven Auger ( 1/4 HP Gear Motor )		
ICE MAKING WATER CONTROL	Float Switch		
COOLING WATER CONTROL	N/A		
BIN CONTROL SYSTEM	Mechanical Bin Control ( Proximity Sw. )		
CONDENSING UNIT	Required refrigeration capacity for ice maker is 5700 BTU/h at discharge pressure 213 PSIG and suction pressure 31.2 PSIG with R-404A refrigerant. Suction pressure needs to be 31.2 PSIG.		
EVAPORATOR	Copper Tube on Cylinder		
REFRIGERANT CONTROL	Thermostatic Expansion Valve Evaporator Pressure Regulator		
REFRIGERANT CHARGE	R-404A, 3.6 oz. (100g Holding Charge)		
DESIGN PRESSURE	High 427 PSIG, Low 230 PSIG		
P.C. BOARD CIRCUIT PROTECTION	High Voltage Cut-off Relay		
COMPRESSOR PROTECTION	Internal Protector		
GEAR MOTOR PROTECTION	Fuse (3A)		
REFRIGERANT CIRCUIT PROTECTION	Auto-reset High Pressure Control Switch		
LOW WATER PROTECTION	Float Switch and Timer		
ACCESSORIES -SUPPLIED	Spare Fuse		
-REQUIRED	Ice Storage Bin		
OPERATING CONDITIONS	VOLTAGE RANGE	104-127 V	
	AMBIENT TEMP.	45-100° F	
	WATER SUPPLY TEMP.	45-90° F	
	WATER SUPPLY PRESSURE	10-113 PSIG	

We reserve the right to make changes in specifications and design without prior notice.



## F-1001MAF-C

AC SUPPLY VOLTAGE	208-230/60/1 (3 wire with neutral for 115V)		
COMPRESSOR	240 V	4.2 RLA	34 LRA
GEAR MOTOR	120 V	3 FLA	1/4 HP
FAN MOTOR	115 V	0.85FLA	1/15 HP
OTHER	120 V	0.03A	
MAXIMUM FUSE SIZE	15 A		
MAX. HACR BREAKER (USA ONLY)	15 A		
MAX. CIRC. BREAKER (CANADA ONLY)	15 A		
MINIMUM CIRCUIT AMPACITY	15 A		
APPROXIMATE ICE PRODUCTION PER 24 HR. lbs./day ( kg/day ) Reference without *marks	Ambient Temp.(°F)	WATER TEMP. (°F)	
		50	70
	70	*860 (390)	820 (373)
	80	765 (346)	735 (333)
	90	680 (309)	665 (302)
	100	610 (277)	550 (249)
SHAPE OF ICE	Cubelet		
ICE QUALITY	Approx. 80%, Ice (90/70°F, Conductivity 200 µs/cm)		
APPROXIMATE STORAGE CAPACITY	N/A		
ELECTRIC & WATER CONSUMPTION	90/70°F	70/50°F	
ELECTRIC W (kWH/100 lbs.)	1760 (6.4)	1715 (4.8)	
POTABLE WATER gal./24HR (gal./100 lbs.)	80 (12)	103 (12)	
EXTERIOR DIMENSIONS (WxDxH)	22" x 27-3/8" x 25-15/16" (560 x 695 x 658mm)		
EXTERIOR FINISH	Stainless Steel, Galvanized Steel (Rear)		
WEIGHT	Net 176 lbs. ( 80 kg ), Shipping 207 lbs. ( 94 kg )		
CONNECTIONS - ELECTRIC	Permanent - Connection		
- WATER SUPPLY	Inlet 1/2" FPT		
- DRAIN	Outlet 3/4" FPT		
ICE MAKING SYSTEM	Auger type		
HARVESTING SYSTEM	Direct Driven Auger ( 1/4 HP Gear Motor )		
ICE MAKING WATER CONTROL	Float Switch		
COOLING WATER CONTROL	N/A		
BIN CONTROL SYSTEM	Mechanical Bin Control ( Proximity Sw. )		
COMPRESSOR	Hermetic, Model RS70-C1E-PFV		
CONDENSER	Air-cooled, Fin and tube type		
EVAPORATOR	Copper Tube on Cylinder		
REFRIGERANT CONTROL	Thermostatic Expansion Valve		
REFRIGERANT CHARGE	R-404A, 1 lb.12oz. (800g)		
DESIGN PRESSURE	High 427 PSIG, Low 230 PSIG		
P.C. BOARD CIRCUIT PROTECTION	High Voltage Cut-off Relay		
COMPRESSOR PROTECTION	Internal Protector		
GEAR MOTOR PROTECTION	Fuse (3A)		
REFRIGERANT CIRCUIT PROTECTION	Auto-reset High Pressure Control Switch		
LOW WATER PROTECTION	Float Switch and Timer		
ACCESSORIES -SUPPLIED	Spare Fuse		
-REQUIRED	Ice Storage Bin		
OPERATING CONDITIONS	VOLTAGE RANGE	187-253 V	
	AMBIENT TEMP.	45-100° F	
	WATER SUPPLY TEMP.	45-90° F	
	WATER SUPPLY PRESSURE	10-113 PSIG	

We reserve the right to make changes in specifications and design without prior notice.

## F-1001MWF-C

AC SUPPLY VOLTAGE	208-230/60/1 (3 wire with neutral for 115V)				
COMPRESSOR	240 V	4.2 RLA	34 LRA		
GEAR MOTOR	120 V	3 FLA	1/4 HP		
OTHER	120 V	0.03A			
MAXIMUM FUSE SIZE	15 A				
MAX. HACR BREAKER (USA ONLY)	15 A				
MAX. CIRC. BREAKER (CANADA ONLY)	15 A				
MINIMUM CIRCUIT AMPACITY	15 A				
APPROXIMATE ICE PRODUCTION PER 24 HR. lbs./day ( kg/day ) Reference without *marks	7	Ambient Temp.(°F)			
		WATER TEMP. (°F)			
		50	70	90	
		0	*790 (358)	760 (346)	750 (340)
		80	735 (333)	720 (327)	710 (322)
	90	695 (316)	*685 (311)	670 (304)	
	100	660 (299)	645 (294)	*600 (272)	
SHAPE OF ICE	Cubelet				
ICE QUALITY	A	pprox. 80%, Ice (90/70°F, Conductivity 200 µs/cm)			
APPROXIMATE STORAGE CAPACITY	N/A				
ELECTRIC & WATER CONSUMPTION	90/70°F		70/50°F		
ELECTRIC W (kWH/100 lbs.)	1265 (4.3)		1264 (3.8)		
POTABLE WATER	82 (12)		95 (12)		
WATER-COOLED CONDENSER gal./24HR (gal./100 lbs.)	492 (72)		303 (34)		
EXTERIOR DIMENSIONS (WxDxH)	22" x 27-3/8" x 25-15/16" (560 x 695 x 658mm)				
EXTERIOR FINISH	Stainless Steel, Galvanized Steel (Rear)				
WEIGHT	Net 176 lbs. ( 80 kg ), Shipping 207 lbs. ( 94 kg )				
CONNECTIONS - ELECTRIC	Permanent - Connection				
- WATER SUPPLY	Inlet 1/2" FPT	Cond. Inlet 1/2" FPT			
- DRAIN	Outlet 3/4" FPT	Cond. Outlet 3/8" FPT			
ICE MAKING SYSTEM	Auger type				
HARVESTING SYSTEM	Direct Driven Auger ( 1/4 HP Gear Motor )				
ICE MAKING WATER CONTROL	Float Switch				
COOLING WATER CONTROL	N/A				
BIN CONTROL SYSTEM	Mechanical Bin Control ( Proximity Sw. )				
COMPRESSOR	Hermetic, Model RS70-C1E-PFV				
CONDENSER	Water-cooled, Tube in tube type				
EVAPORATOR	Copper Tube on Cylinder				
REFRIGERANT CONTROL	Thermostatic Expansion Valve				
REFRIGERANT CHARGE	R-404A, 15oz. (425g)				
DESIGN PRESSURE	High 427 PSIG, Low 230 PSIG				
P.C. BOARD CIRCUIT PROTECTION	High Voltage Cut-off Relay				
COMPRESSOR PROTECTION	Internal Protector				
GEAR MOTOR PROTECTION	Fuse (3A)				
REFRIGERANT CIRCUIT PROTECTION	Auto-reset High Pressure Control Switch				
LOW WATER PROTECTION	Float Switch and Timer				
ACCESSORIES -SUPPLIED	Spare Fuse				
-REQUIRED	Ice Storage Bin				
OPERATING CONDITIONS	VOLTAGE RANGE	187-253 V			
	AMBIENT TEMP.	45-100° F			
	WATER SUPPLY TEMP.	45-90° F			
	WATER SUPPLY PRESSURE	10-113 PSIG			

We reserve the right to make changes in specifications and design without prior notice.

## F-1001MRF-C

AC SUPPLY VOLTAGE	208-230/60/1 (3 wire with neutral for 115V)		
COMPRESSOR	240 V	4.2 RLA	34 LRA
GEAR MOTOR	120 V	3 FLA	1/4 HP
FAN MOTOR REMOTE	120 V	3A	MAX
OTHER	120 V	0.03A	
MAXIMUM FUSE SIZE	15 A		
MAX. HACR BREAKER (USA ONLY)	15 A		
MAX. CIRC. BREAKER (CANADA ONLY)	15 A		
MINIMUM CIRCUIT AMPACITY	15 A		
APPROXIMATE ICE PRODUCTION PER 24 HR. lbs./day ( kg/day ) Reference without *marks	Ambient Temp.(°F)	WATER TEMP. (°F)	
		50	70
	70	*840 (381)	810 (368)
	80	765 (347)	745 (337)
	90	700 (317)	*695 (315)
	100	640 (290)	*575 (261)
SHAPE OF ICE	Cubelet		
ICE QUALITY	Approx. 80%, Ice (90/70°F, Conductivity 200 µs/cm)		
APPROXIMATE STORAGE CAPACITY	N/A		
ELECTRIC & WATER CONSUMPTION	90/70°F	70/50°F	
ELECTRIC W (kWH/100 lbs.)	1605 (5.5)	1610 (4.6)	
POTABLE WATER gal./24HR (gal./100 lbs.)	83 (12)	101(12)	
EXTERIOR DIMENSIONS (WxDxH)	22" x 27-3/8" x 25-15/16" (560 x 695 x 658mm)		
EXTERIOR FINISH	Stainless Steel, Galvanized Steel (Rear)		
WEIGHT	Net 176 lbs. ( 80 kg ), Shipping 207 lbs. ( 94 kg )		
CONNECTIONS - ELECTRIC	Permanent - Connection		
- WATER SUPPLY	Inlet 1/2" FPT		
- DRAIN	Outlet 3/4" FPT		
- REFRIGERATION	Discharge line 1-1/16-12 UNF Fitting (#10 AEROQUIP)		
CIRCUIT	Liquid line 5/8-18 UNF Fitting (#6 AEROQUIP)		
ICE MAKING SYSTEM	Auger type		
HARVESTING SYSTEM	Direct Driven Auger ( 1/4 HP Gear Motor )		
ICE MAKING WATER CONTROL	Float Switch		
COOLING WATER CONTROL	N/A		
BIN CONTROL SYSTEM	Mechanical Bin Control ( Proximity Sw. )		
COMPRESSOR	Hermetic, Model RS70-C1E-PFV		
CONDENSER	Air-cooled Remote Condenser unit URC-6F Recommended		
EVAPORATOR	Copper Tube on Cylinder		
REFRIGERANT CONTROL	Thermostatic Expansion Valve		
	Condensing Pressure Regulator on URC-6F		
REFRIGERANT CHARGE	R-404A, 4 lb.1oz. (1850g) (Ice Maker: 2 lb. 3 oz., Cond. Unit: 1 lb. 14 oz. )		
DESIGN PRESSURE	High 427 PSIG, Low 230 PSIG		
P.C. BOARD CIRCUIT PROTECTION	High Voltage Cut-off Relay		
COMPRESSOR PROTECTION	Internal Protector		
GEAR MOTOR PROTECTION	Fuse (3A)		
REFRIGERANT CIRCUIT PROTECTION	Auto-reset High Pressure Control Switch		
LOW WATER PROTECTION	Float Switch and Timer		
ACCESSORIES -SUPPLIED	Spare Fuse		
-REQUIRED	Ice Storage Bin		
OPERATING CONDITIONS	VOLTAGE RANGE	187-253 V	
	AMBIENT TEMP.	45-100° F	
	WATER SUPPLY TEMP.	45-90° F	
	WATER SUPPLY PRESSURE	10-113 PSIG	

We reserve the right to make changes in specifications and design without prior notice.

## F-1001MLF-C

AC SUPPLY VOLTAGE	115/60/1		
GEAR MOTOR	120 V	3 FLA	1/4 HP
OTHER	120 V	0.03A	
MAXIMUM FUSE SIZE	15 A		
MAX. HACR BREAKER (USA ONLY)	15 A		
MAX. CIRC. BREAKER (CANADA ONLY)	15 A		
MINIMUM CIRCUIT AMPACITY	15 A		
APPROXIMATE ICE PRODUCTION PER 24 HR.	Ambient Temp. (F)	WATER TEMP. (F)	
lbs./day ( kg/day )		50	70
	70	1020 (463)	945 (428)
This data is for reference only, different condensing unit will vary data.	80	885 (402)	860 (390)
	90	805 (366)	795 (361)
	100	735 (333)	710 (323)
		90	915 (415)
			835 (378)
			760 (344)
			640 (290)
SHAPE OF ICE	Cubelet		
ICE QUALITY	Approx. 80%, Ice (90/70°F, Conductivity 200 µs/cm)		
APPROXIMATE STORAGE CAPACITY	N/A		
ELECTRIC & WATER CONSUMPTION	90/70°F	70/50°F	
ELECTRIC W (kWH/100 lbs.)	655 (2.0)	655 (1.5)	
POTABLE WATER gal./24HR (gal./100 lbs.)	95 (12)	122 (12)	
EXTERIOR DIMENSIONS (WxDxH)	22" x 27-3/8" x 25-15/16" (560 x 695 x 658mm)		
EXTERIOR FINISH	Stainless Steel, Galvanized Steel (Rear)		
WEIGHT	Net 114 lbs. ( 52 kg ), Shipping 146 lbs. ( 66 kg )		
CONNECTIONS - ELECTRIC	Permanent - Connection		
- WATER SUPPLY	Inlet 1/2" FPT		
- DRAIN	Outlet 3/4" FPT		
- REFRIGERATION CIRCUIT	Outlet (Vapor) line 1-1/16-12 UNF Fitting (#10 AEROQUIP) Inlet (Liquid) line 5/8-18 UNF Fitting (#6 AEROQUIP)		
ICE MAKING SYSTEM	Auger type		
HARVESTING SYSTEM	Direct Driven Auger ( 1/4 HP Gear Motor )		
ICE MAKING WATER CONTROL	Float Switch		
COOLING WATER CONTROL	N/A		
BIN CONTROL SYSTEM	Mechanical Bin Control ( Proximity Sw. )		
CONDENSING UNIT	Required refrigeration capacity for ice maker is 5700 BTU/h at discharge pressure 213 PSIG and suction pressure 31.2 PSIG with R-404A refrigerant. Suction pressure needs to be 31.2 PSIG.		
EVAPORATOR	Copper Tube on Cylinder		
REFRIGERANT CONTROL	Thermostatic Expansion Valve Evaporator Pressure Regulator		
REFRIGERANT CHARGE	R-404A, 3.6 oz. (100g Holding Charge)		
DESIGN PRESSURE	High 427 PSIG, Low 230 PSIG		
P.C. BOARD CIRCUIT PROTECTION	High Voltage Cut-off Relay		
COMPRESSOR PROTECTION	Internal Protector		
GEAR MOTOR PROTECTION	Fuse (3A)		
REFRIGERANT CIRCUIT PROTECTION	Auto-reset High Pressure Control Switch		
LOW WATER PROTECTION	Float Switch and Timer		
ACCESSORIES -SUPPLIED	Spare Fuse		
-REQUIRED	Ice Storage Bin		
OPERATING CONDITIONS	VOLTAGE RANGE	104-127 V	
	AMBIENT TEMP.	45-100° F	
	WATER SUPPLY TEMP.	45-90° F	
	WATER SUPPLY PRESSURE	10-113 PSIG	

We reserve the right to make changes in specifications and design without prior notice.

## 2. CONDENSER UNIT

URC-6F

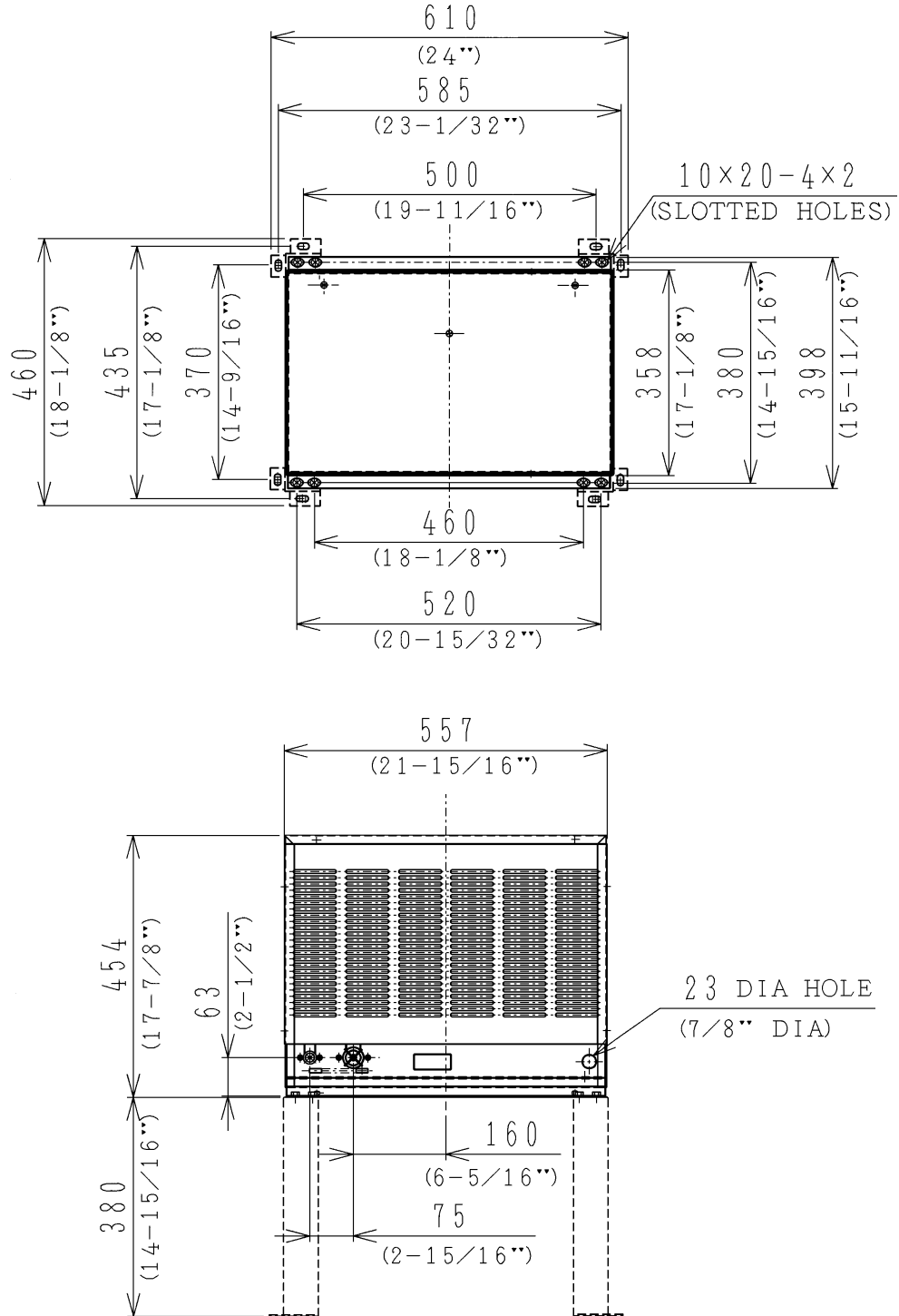

## SPECIFICATIONS

MODEL: URC-6F	
EXTERIOR	Galvanized Steel
DIMENSIONS (W x D x H)	21-15/16" x 15-11/16" x 17-7/8" (557 x 398 x 454 mm)
REFRIGERANT CHARGE	R404A 1 lb. 14 oz. (850 g)
WEIGHT	Net 61 lbs. (28 kg) Shipping 68 lbs. (31 kg)
CONNECTIONS REFRIGERANT ELECTRICAL	One Shot Couplings (Aeroquip) Permanent Connection
CONDENSER	Air-cooled
HEAD PRESSURE CONTROL	Condensing Pressure Regulator
AMBIENT CONDITION	Min. -20°F - Max. +122°F (-29°C to +50°C) Outdoor use

## II. GENERAL INFORMATION

### 1. CONSTRUCTION

F-1001MAF/-C

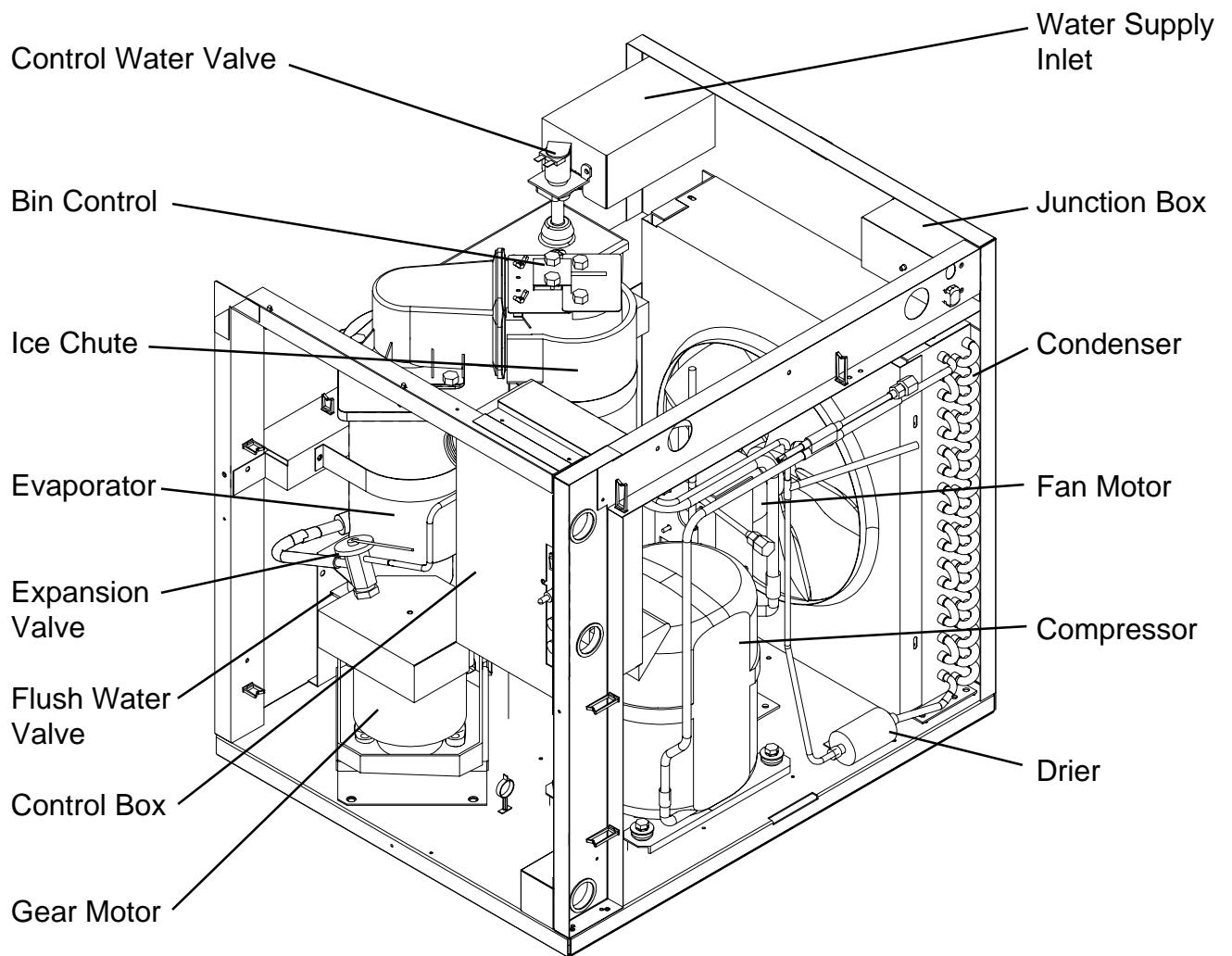

**F-1001MWF/-C**

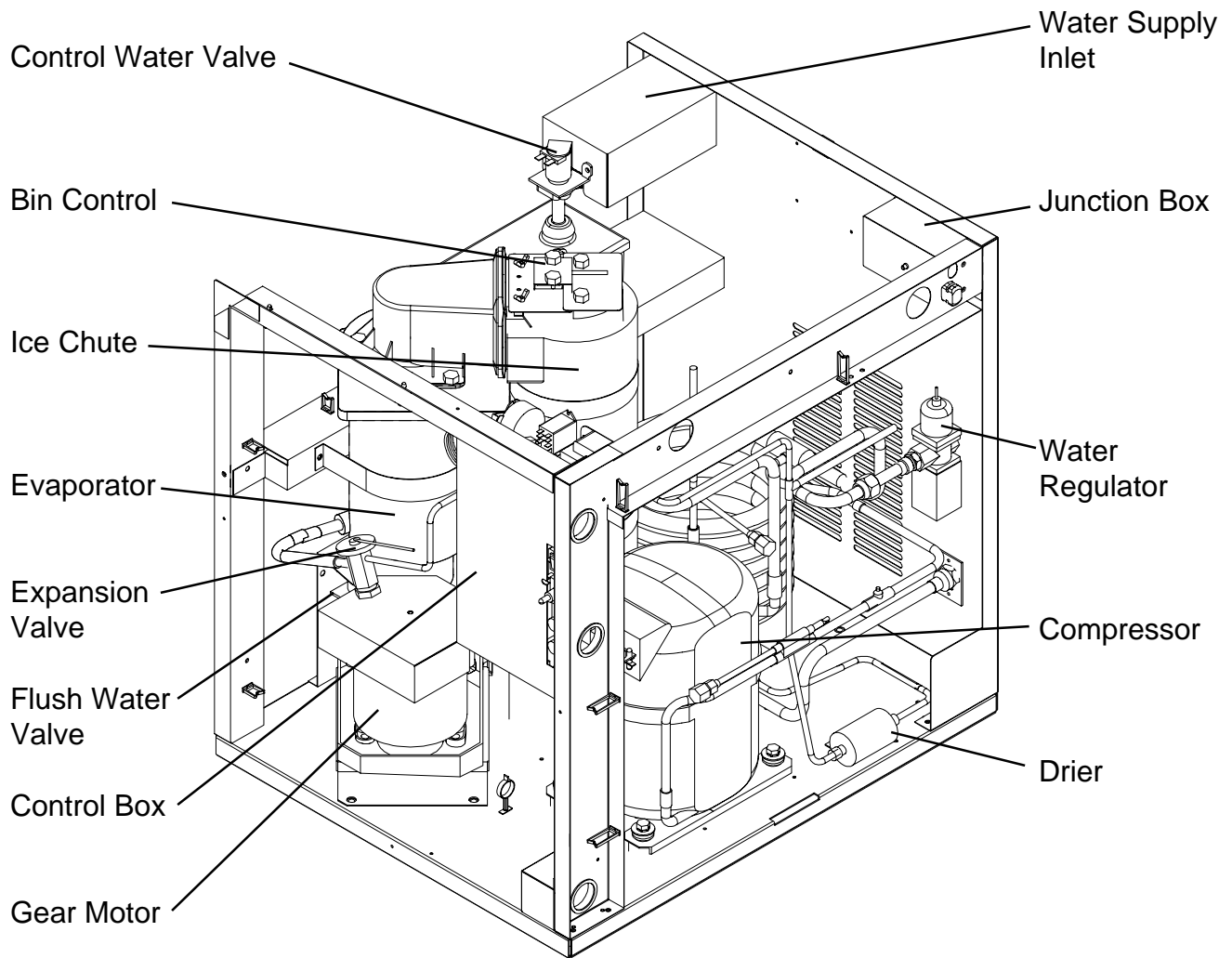



# F-1001MRF/-C

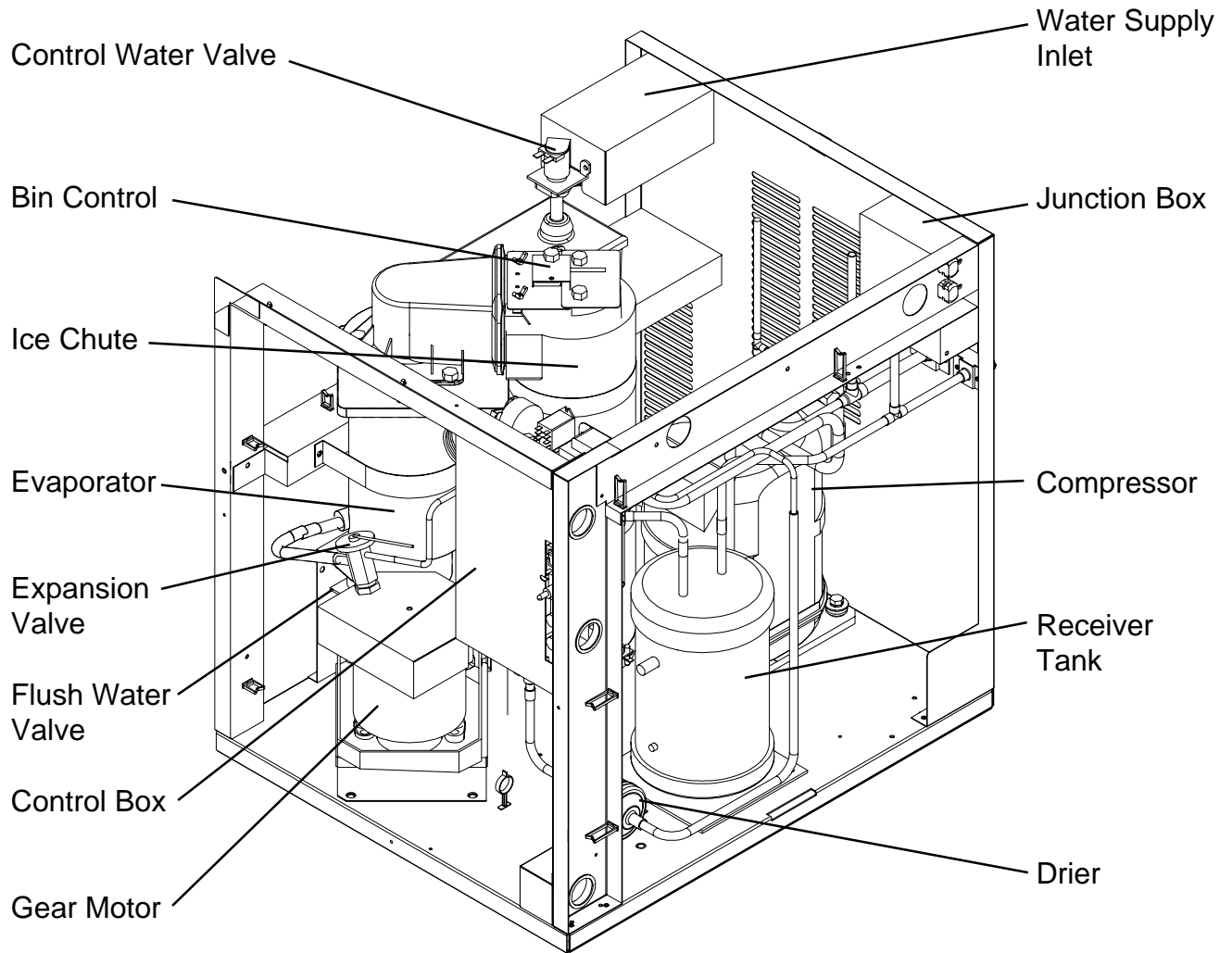

# F-1001MLF/-C

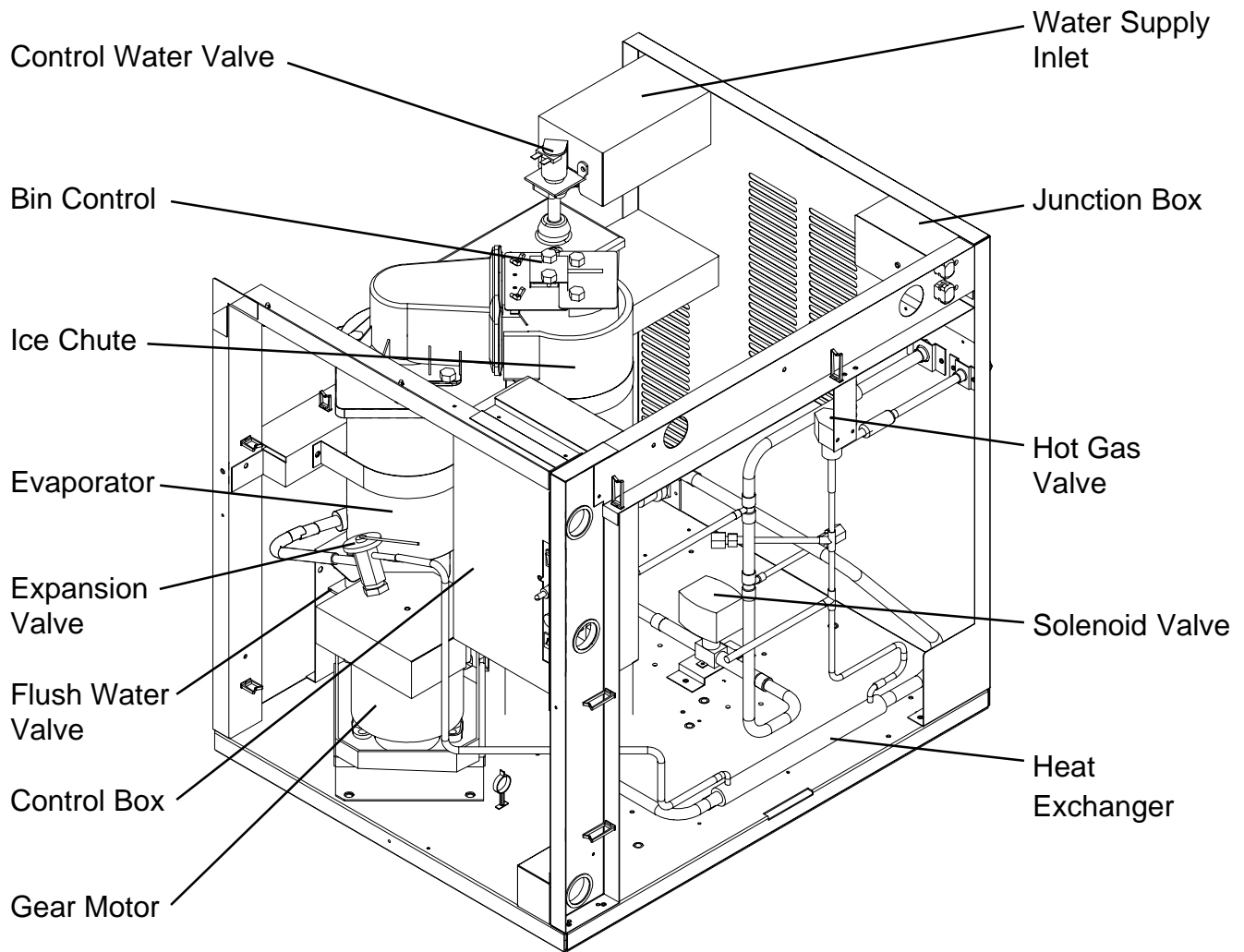

## 2. CONTROL BOX LAYOUT

F-1001MAF/-C

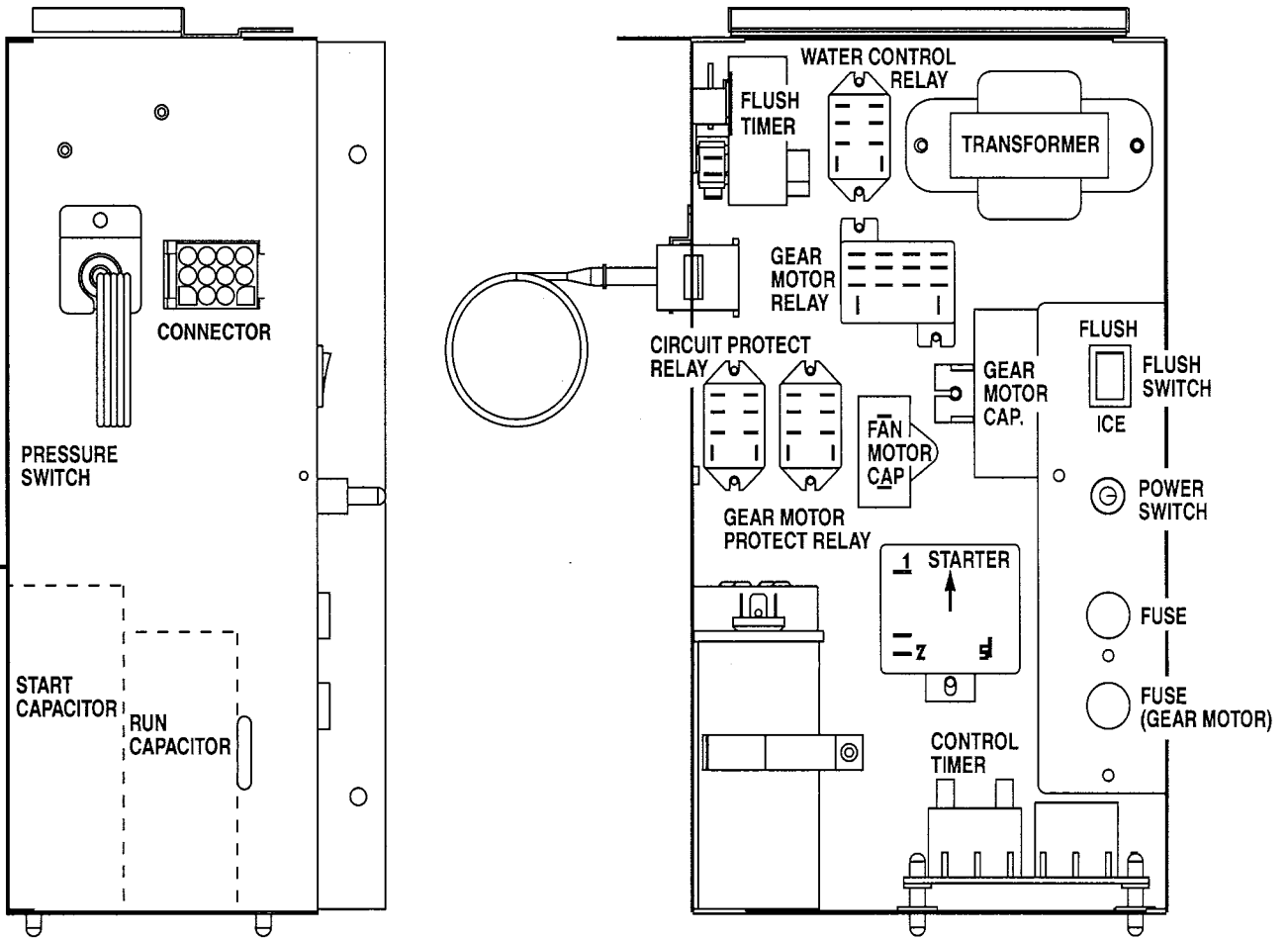

Note: The above component names are identical with the Wiring Label, but not with the Parts List.

F-1001MWF, F-1001MRF/-C

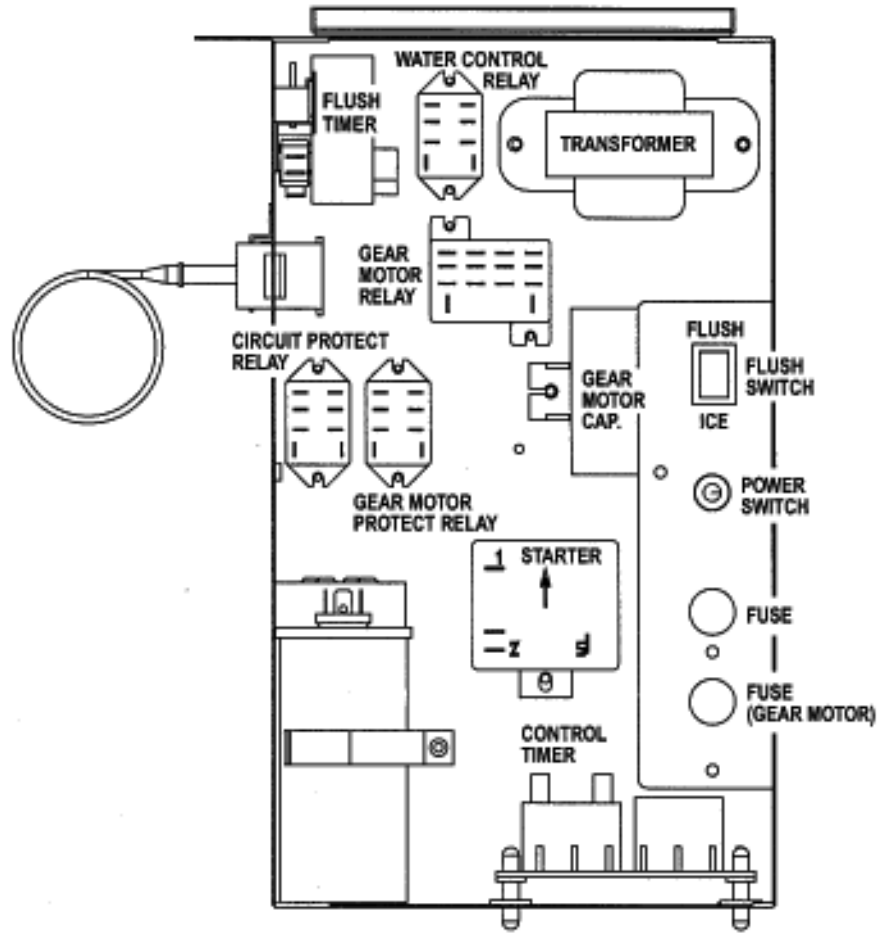
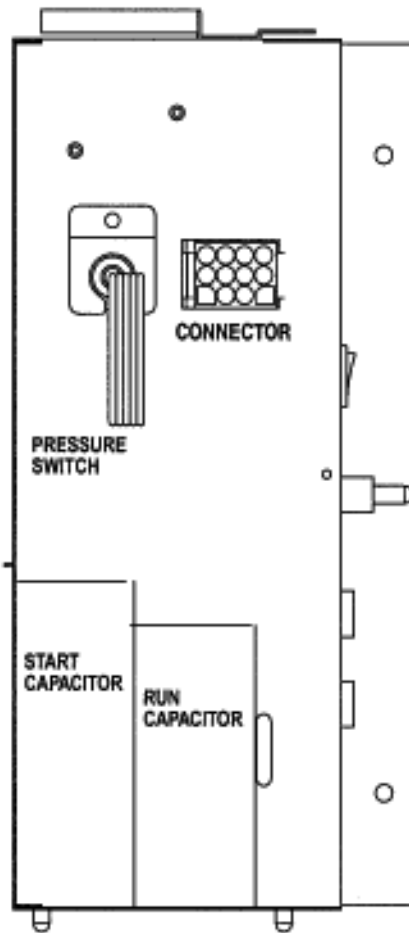

F-1001MLF/C

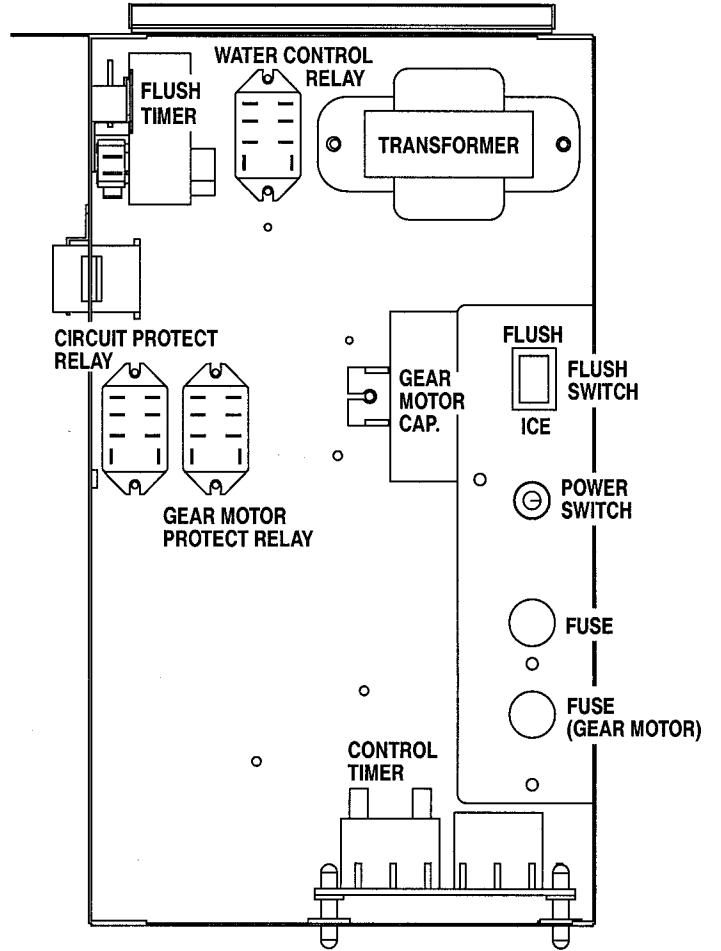
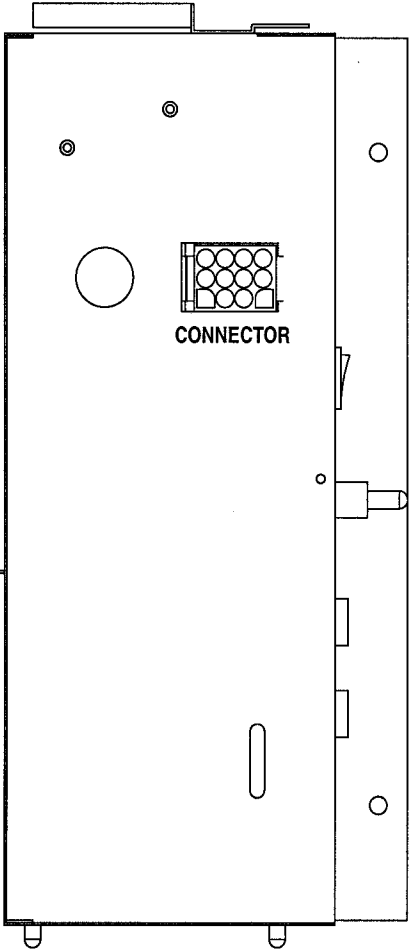

### III. TECHNICAL INFORMATION

#### 1. WATER CIRCUIT AND REFRIGERATION CIRCUIT

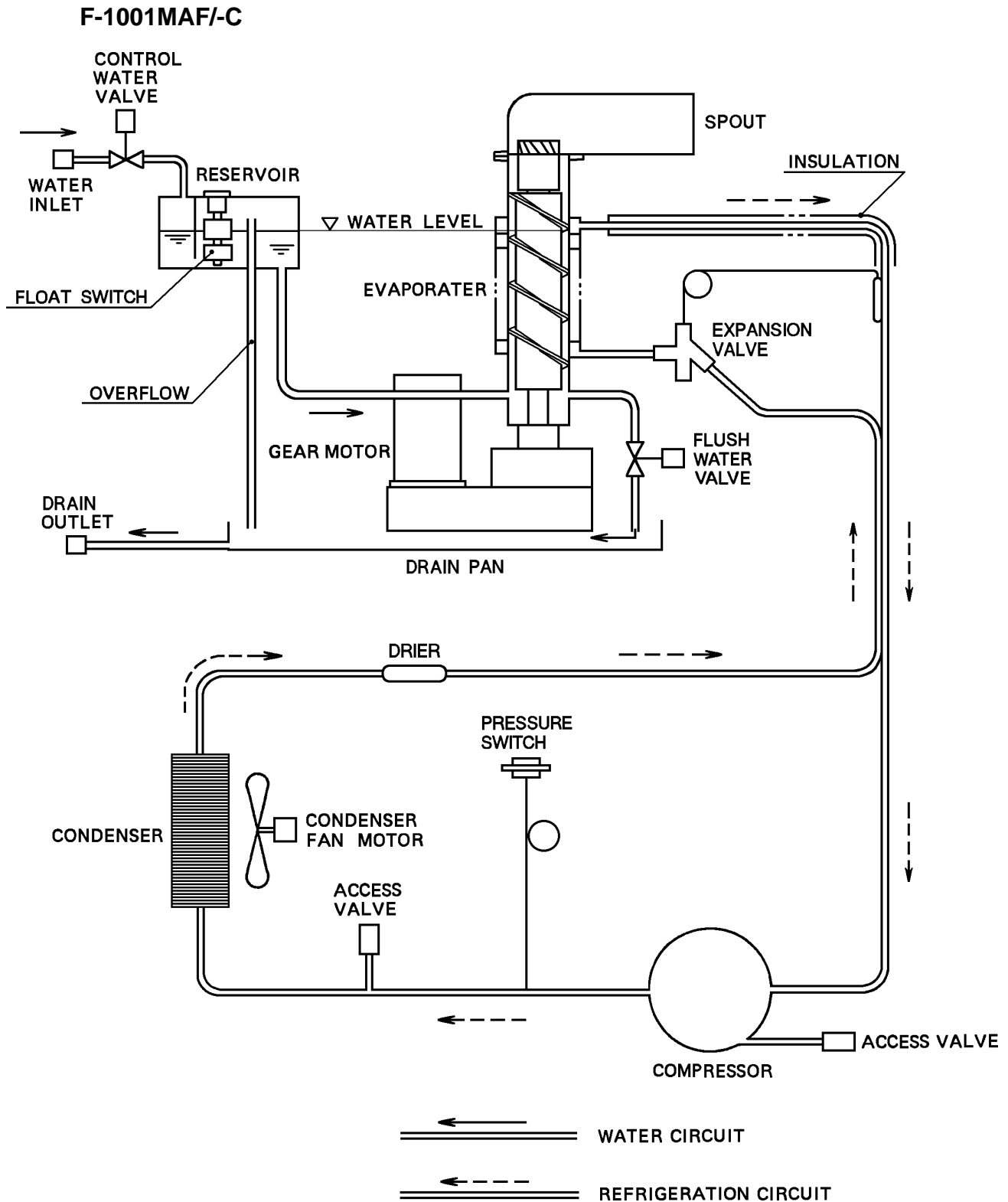

F-1001MWF/-C

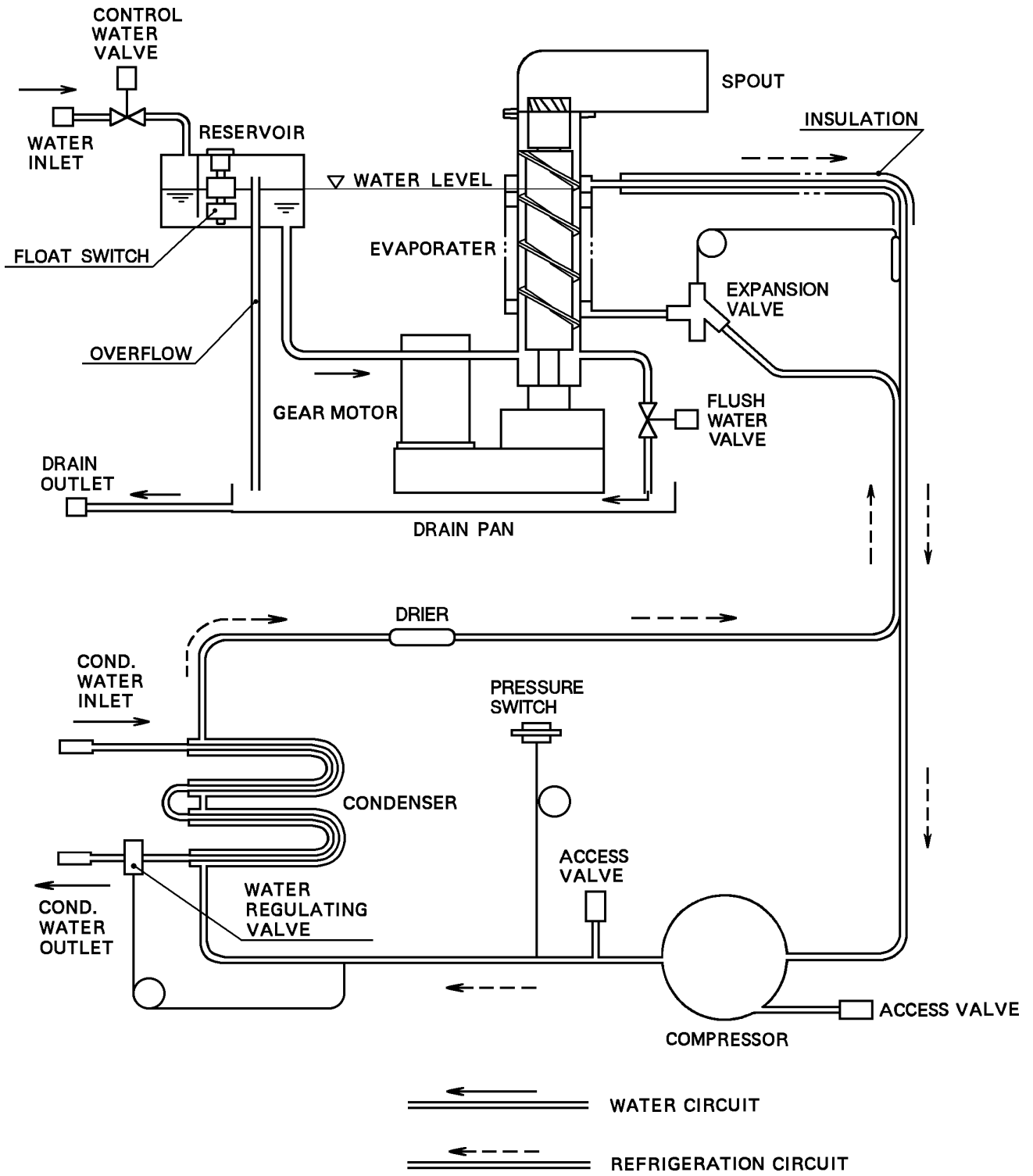

F-1001MRF/-C

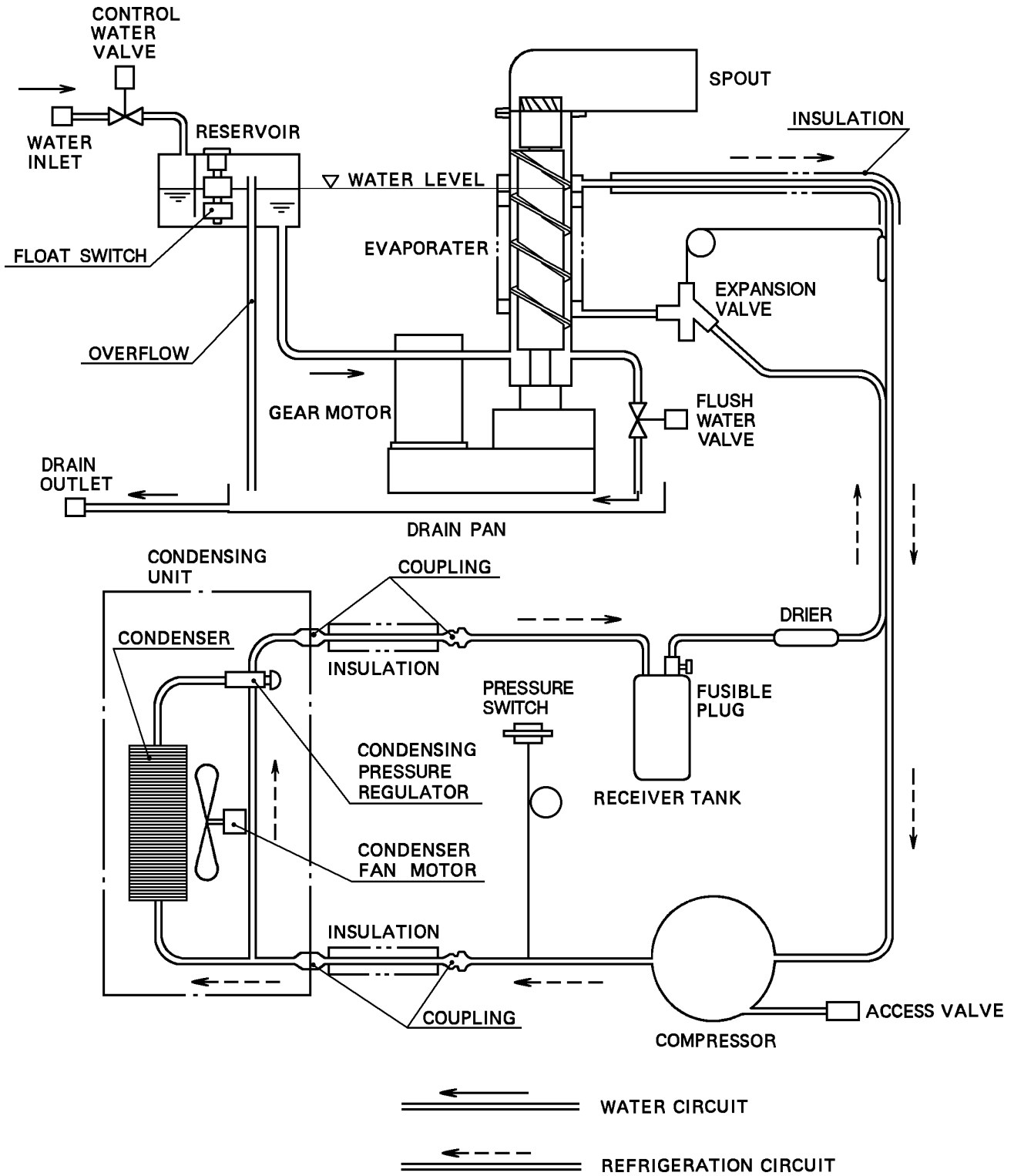



F-1001MLF/C

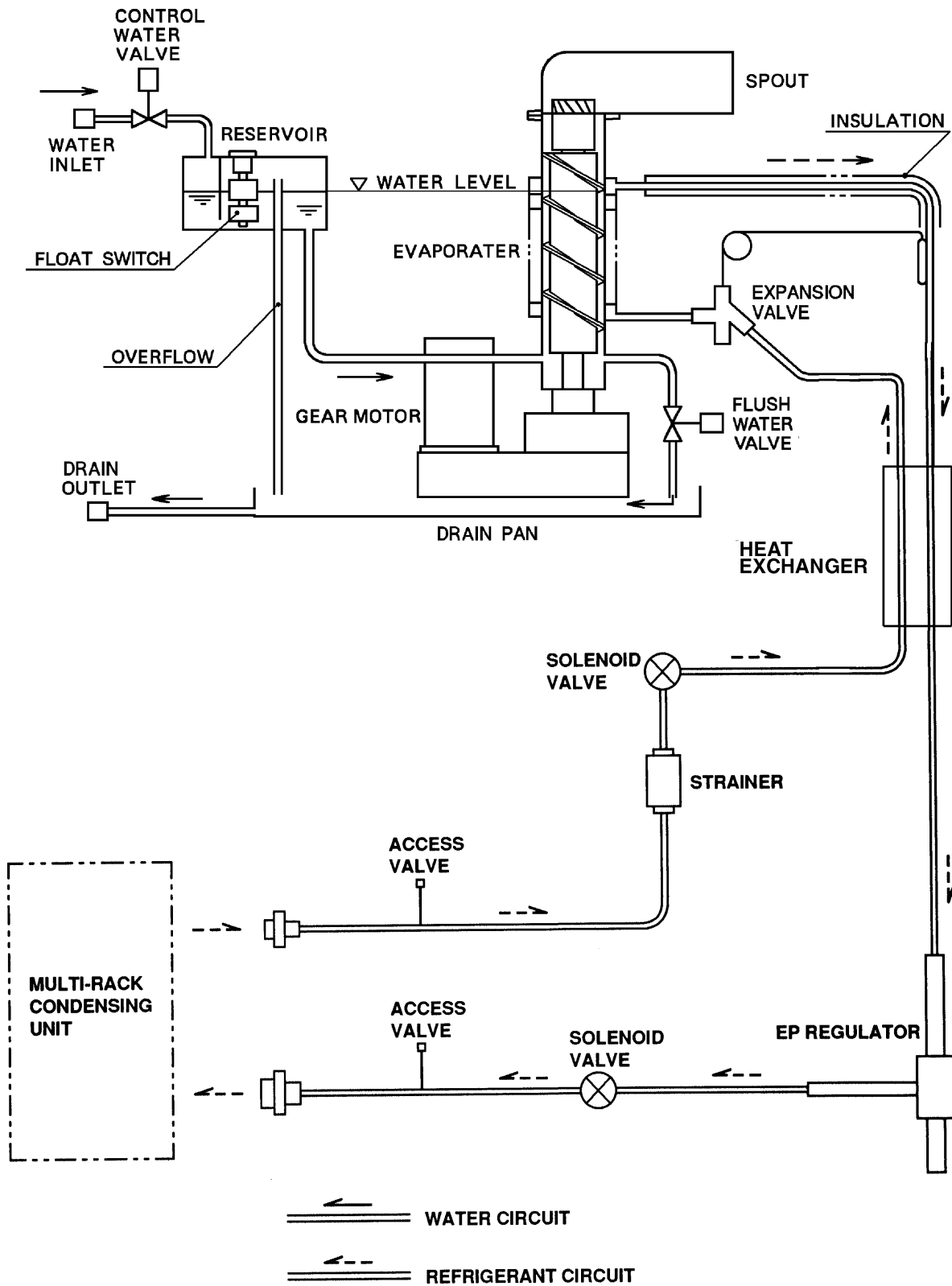

## 2. WIRING DIAGRAMS

### F-1001MAF/-C, F-1001MWF/-C, F-1001MRF/-C

BK...BLACK  
 BR...BROWN  
 DBU...DARK BLUE  
 GY...GRAY  
 LBU...LIGHT BLUE  
 Y...YELLOW  
 W/BU...WHITE/BLUE  
 W/BK...WHITE/BLACK  
 O...ORANGE  
 P...PINK  
 R...RED  
 V...VIOLET  
 W...WHITE  
 W/R...WHITE/RED  
 W/BR...WHITE/BROWN  
 W/O...WHITE/ORANGE

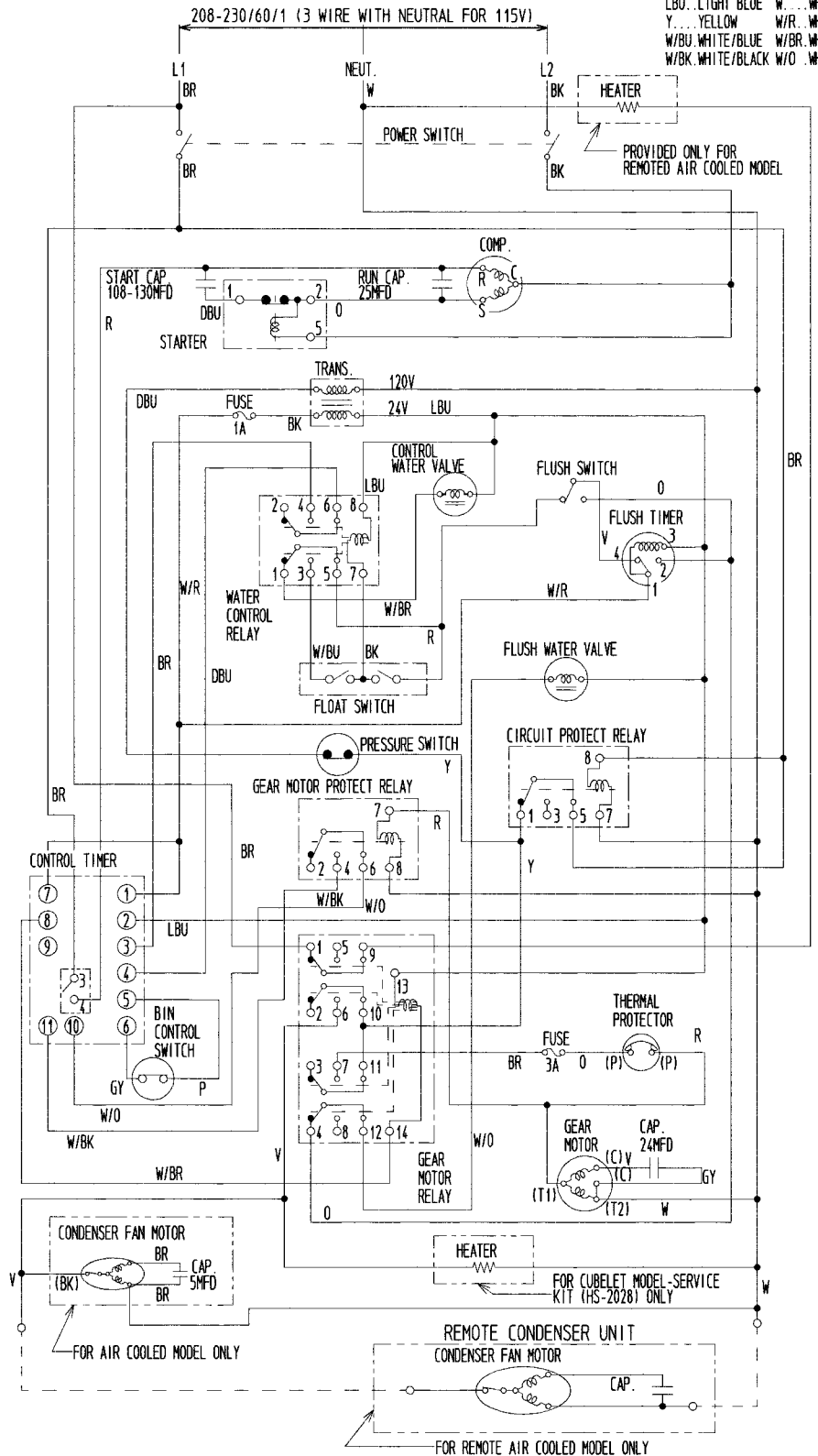

# F-1001MLF/C

- |                    |                    |
|--------------------|--------------------|
| BK...BLACK         | O...ORANGE         |
| BR...BROWN         | P...PINK           |
| DBU...DARK BLUE    | R...RED            |
| GY...GRAY          | V...VIOLET         |
| LBU...LIGHT BLUE   | W...WHITE          |
| Y...YELLOW         | W/R...WHITE/RED    |
| W/BU...WHITE/BLUE  | W/BR...WHITE/BROWN |
| W/BK...WHITE/BLACK | W/O...WHITE/ORANGE |

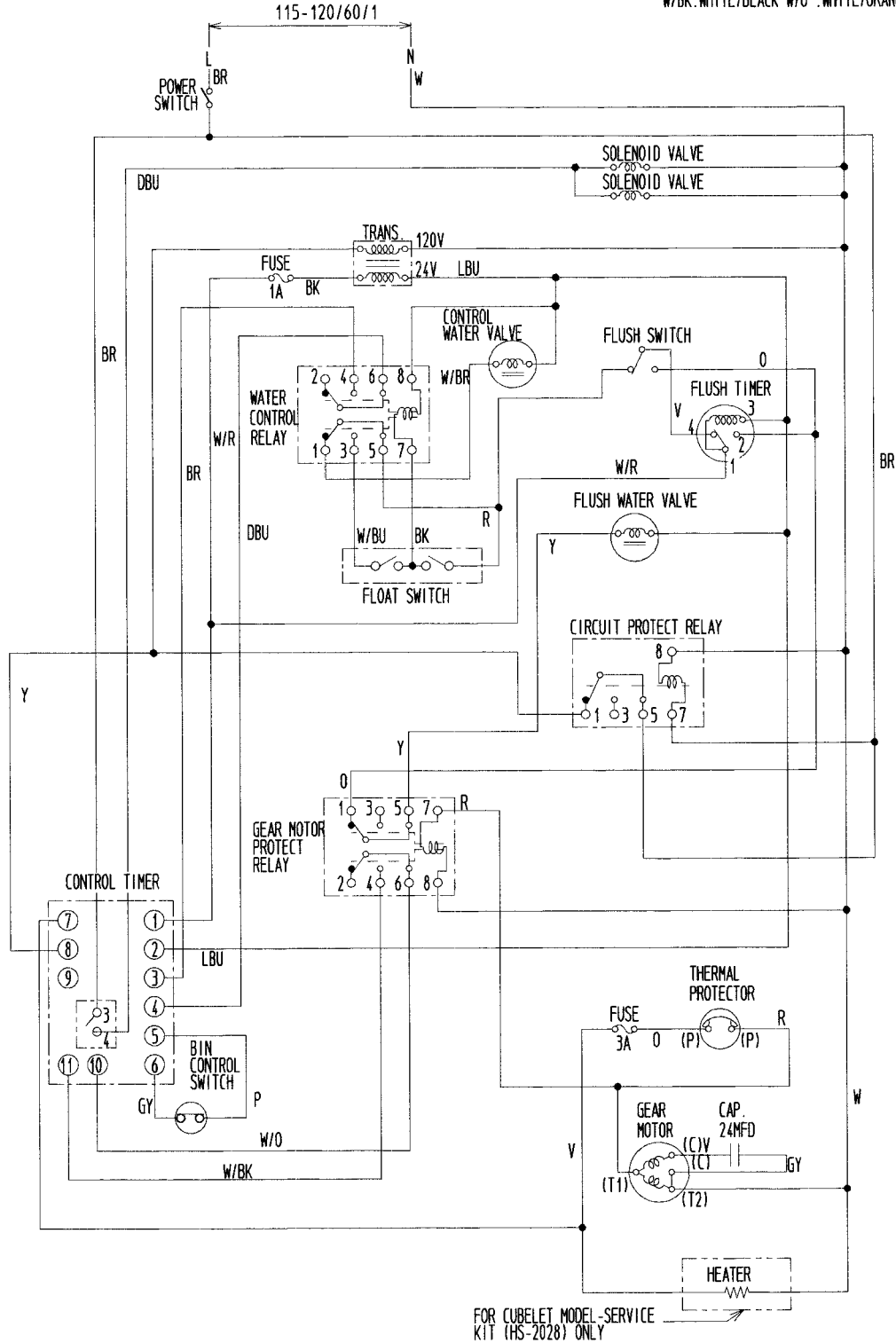

### 3. SEQUENCE OF ELECTRICAL CIRCUIT

[a] When Power Switch is moved to "ON" position and Flush Switch to "ICE" position, water starts to be supplied to Reservoir.

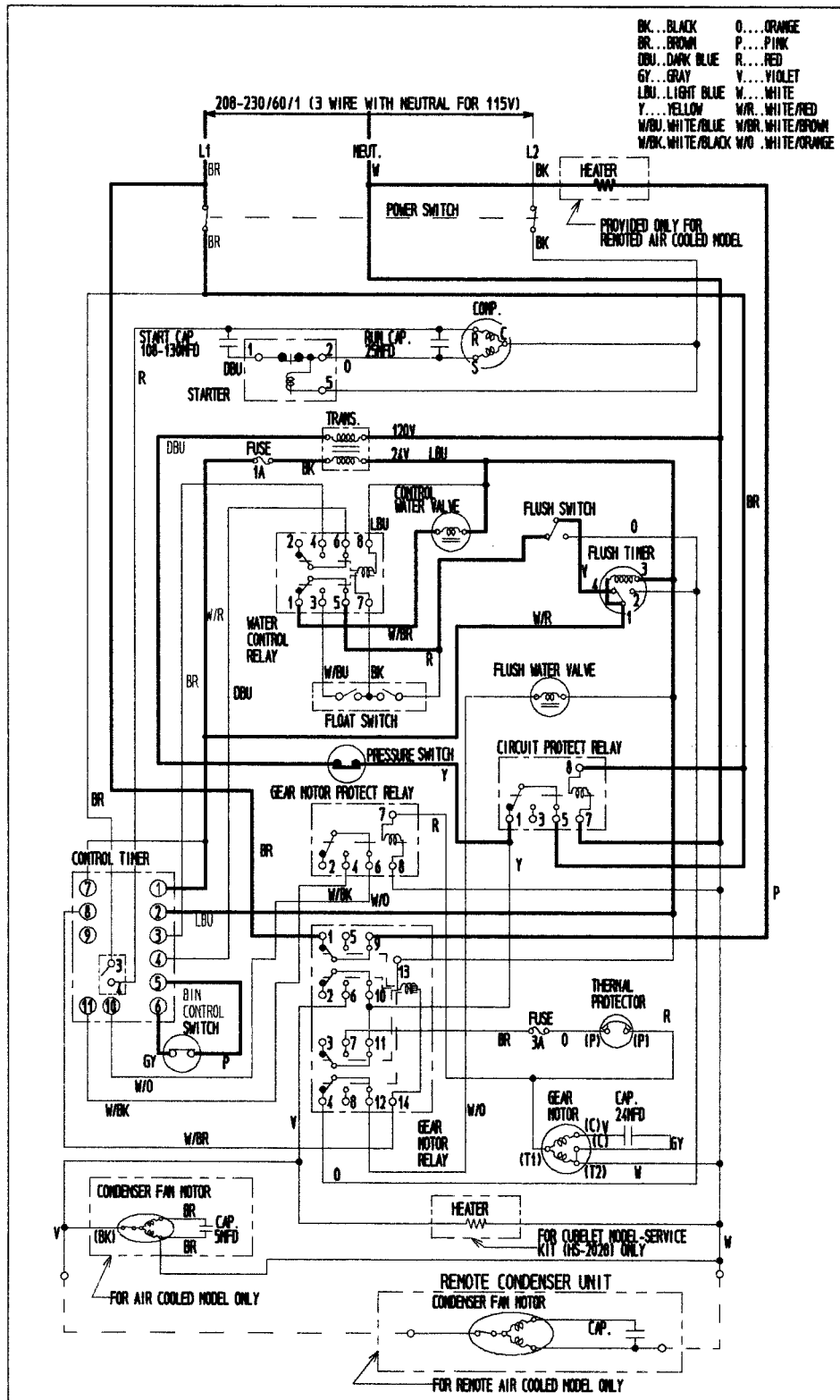

[b] When Reservoir has been filled, Gear Motor starts immediately.

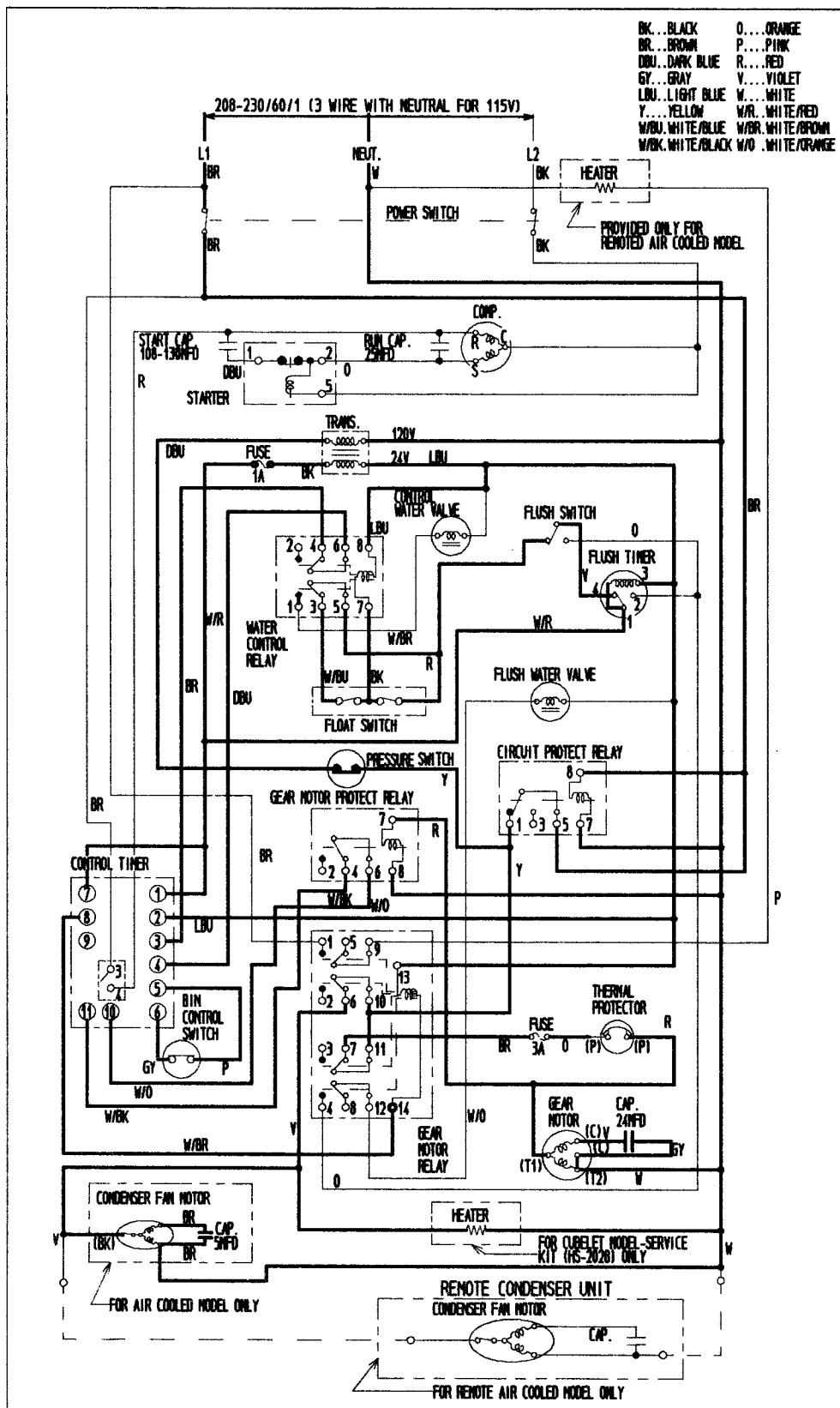

[c] Compressor starts about 60 sec. after Gear Motor starts.

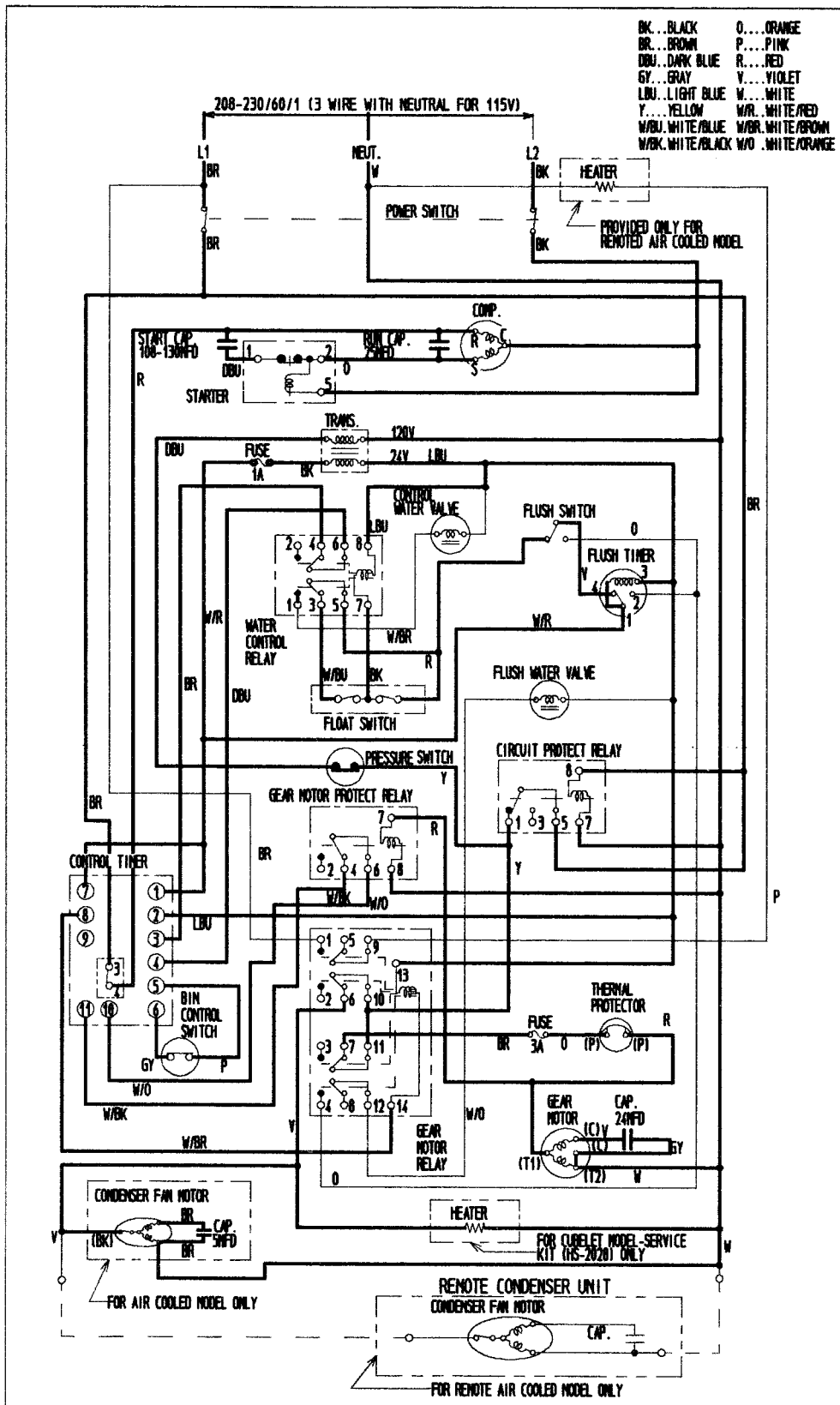

[d] Bin Control operates, and about 6 sec. later, Compressor and Gear Motor stop simultaneously.

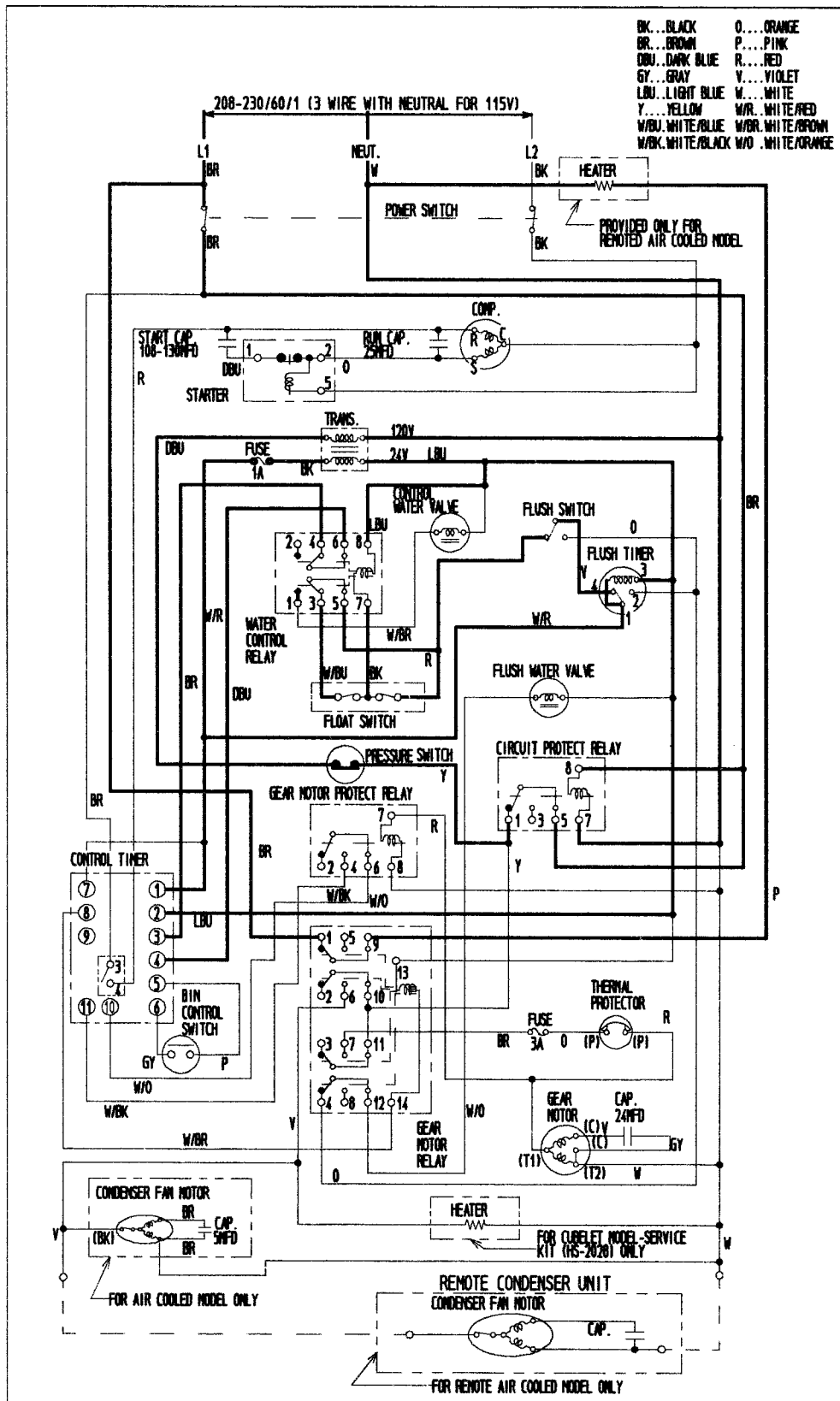

[e] Low Water (Except Water-cooled Model).

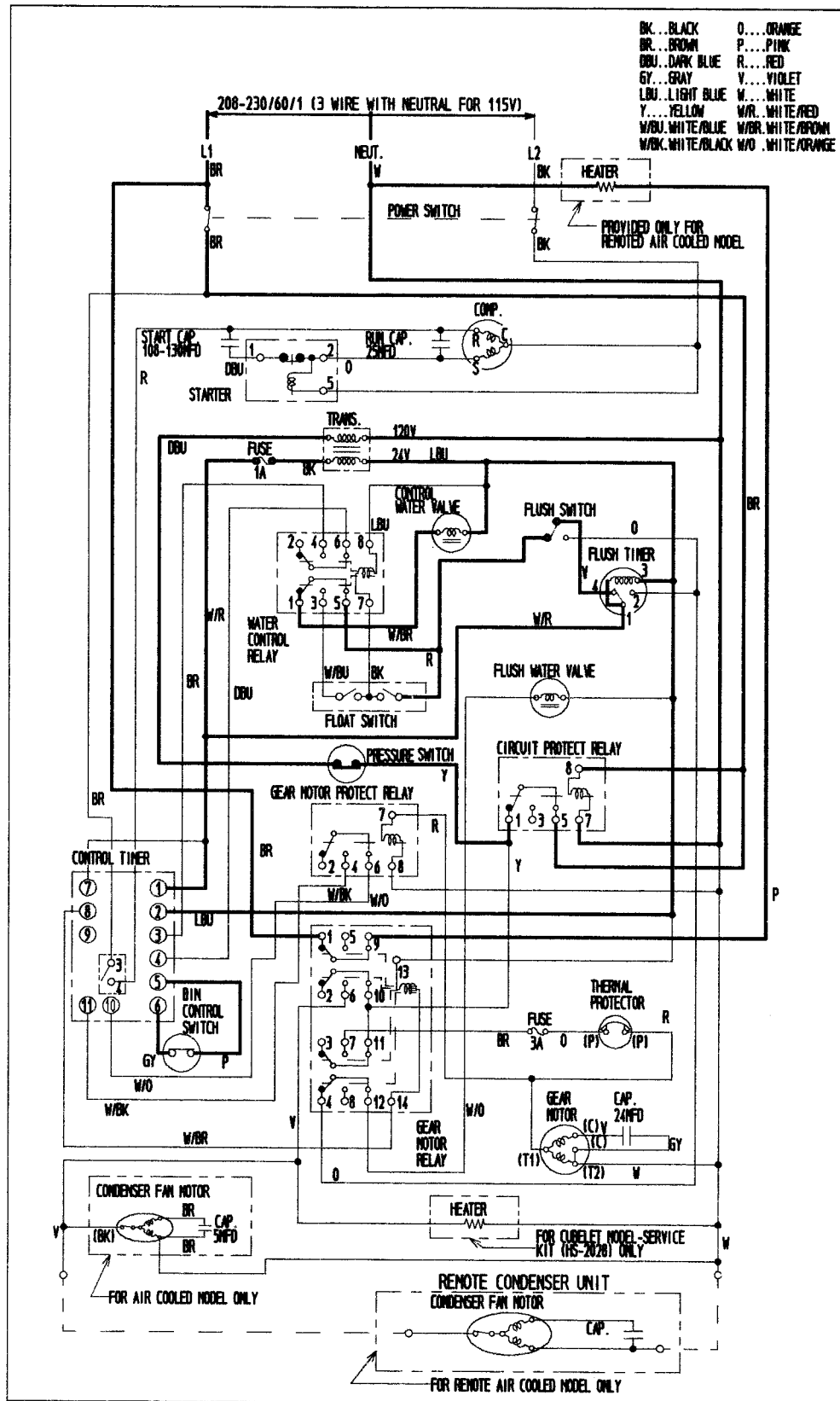



[f] Low Water (Water-cooled Model), or Dirty Air Filter (Air-cooled Model), Pressure Switch to "OPEN", Compressor and Gear Motor operates intermittently.

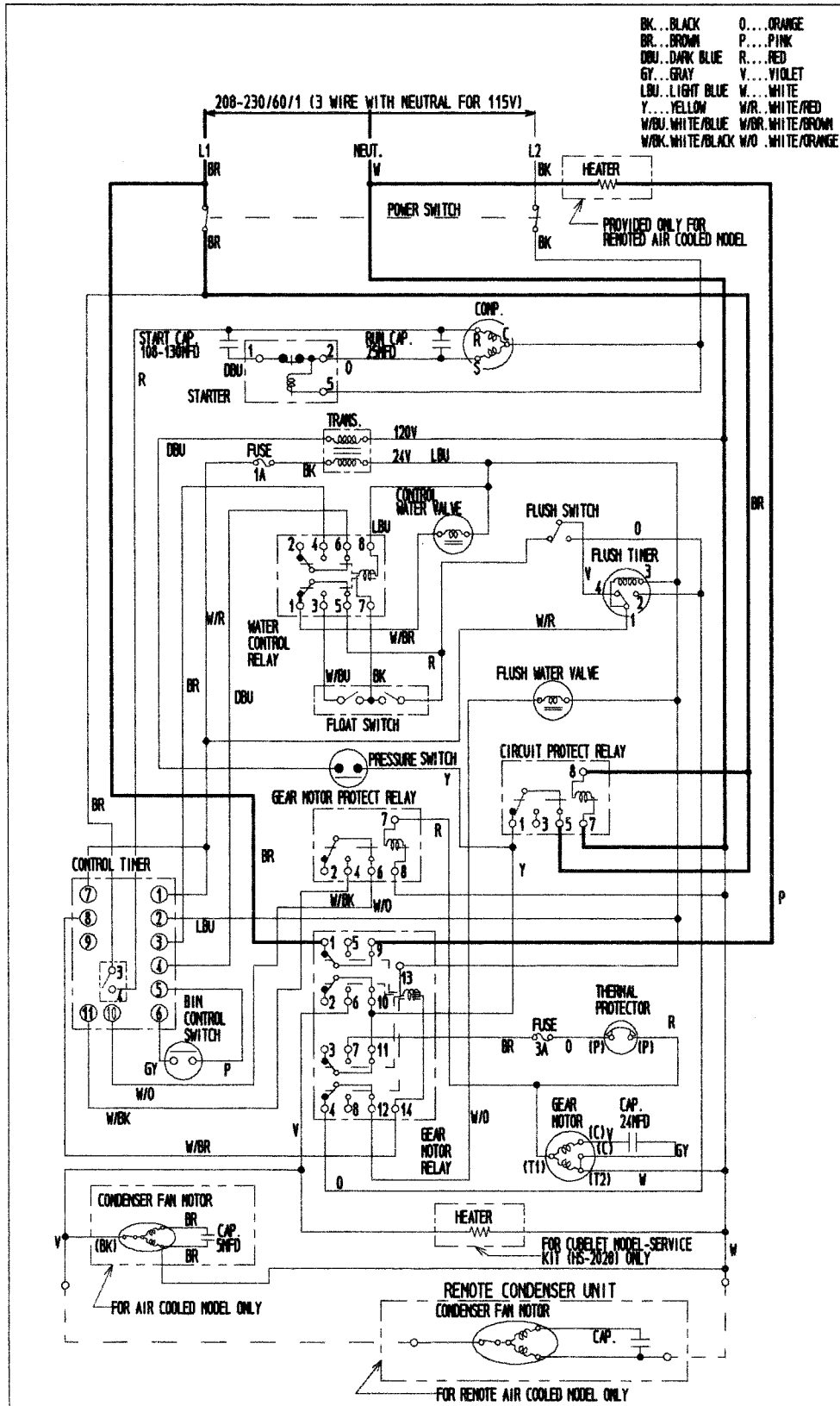

[g] When Flush Switch is moved to "FLUSH" position, Flush Water Valve opens and flushes Reservoir and Evaporator.

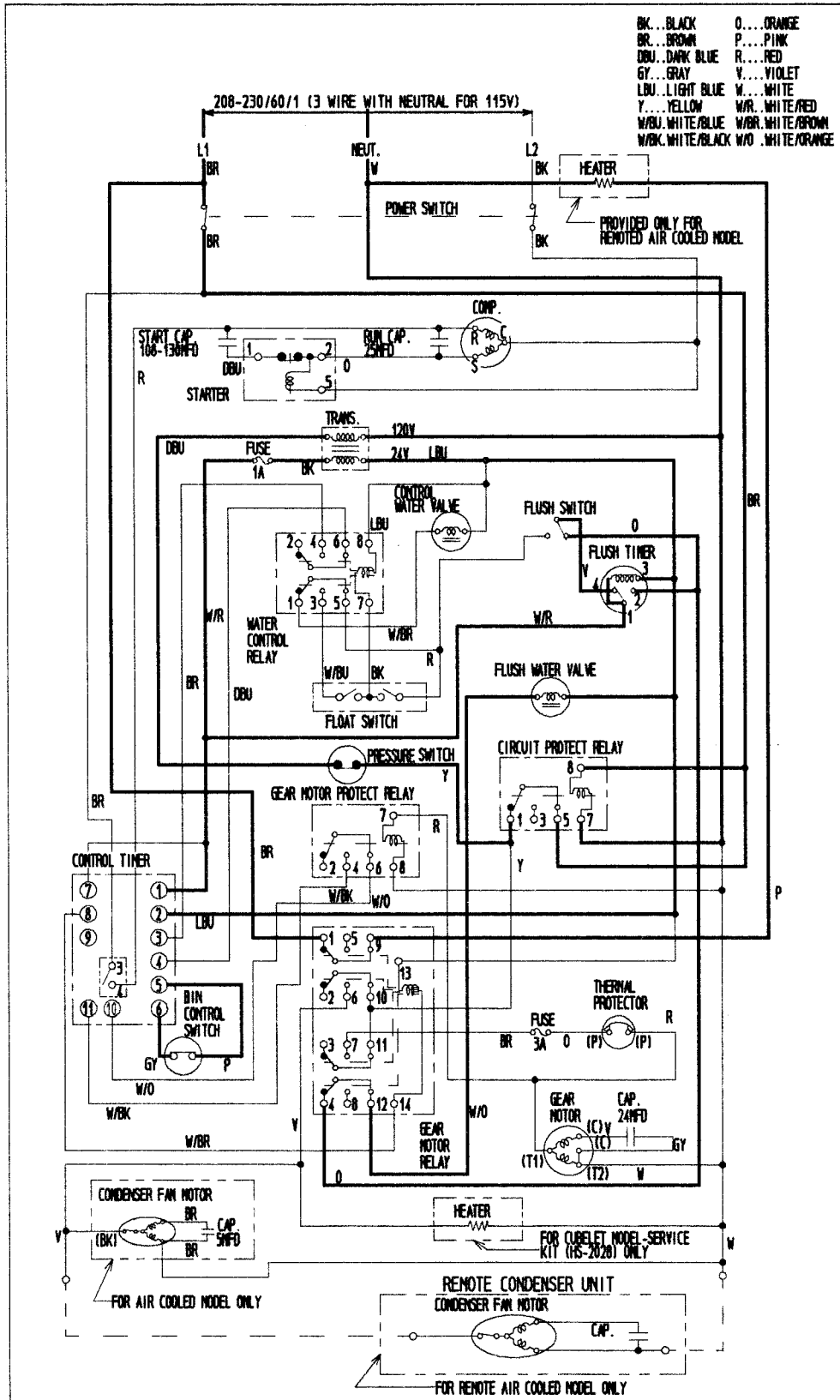

[h] When Flush Timer operates (for 15 min. every 12 hours).

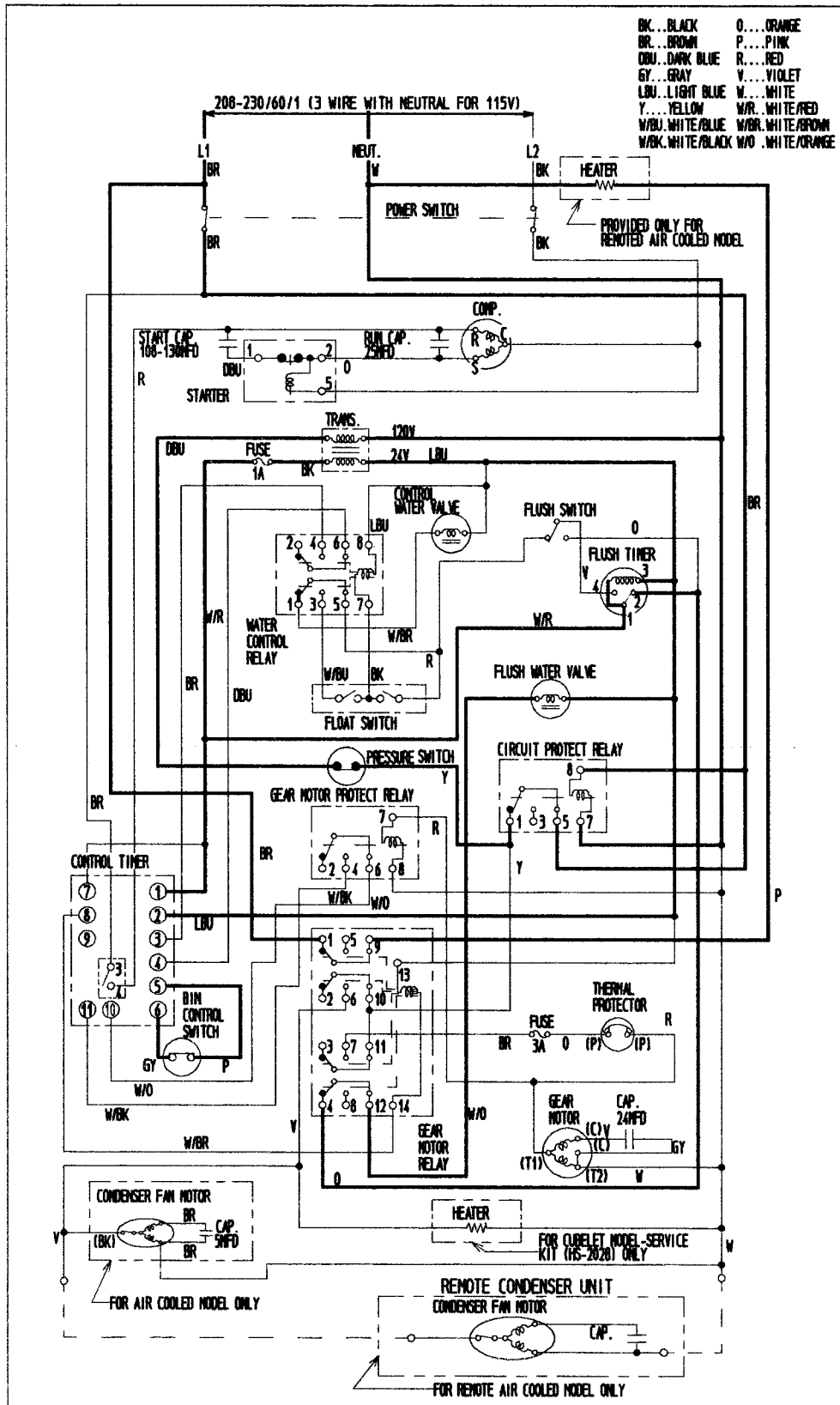

- [i] When 208-230V are supplied to Circuit Protect Relay, it protects the circuit from miswiring. If the power supply is is properly connected, the contact of Circuit Protect Relay does not move even when the coil is energized.

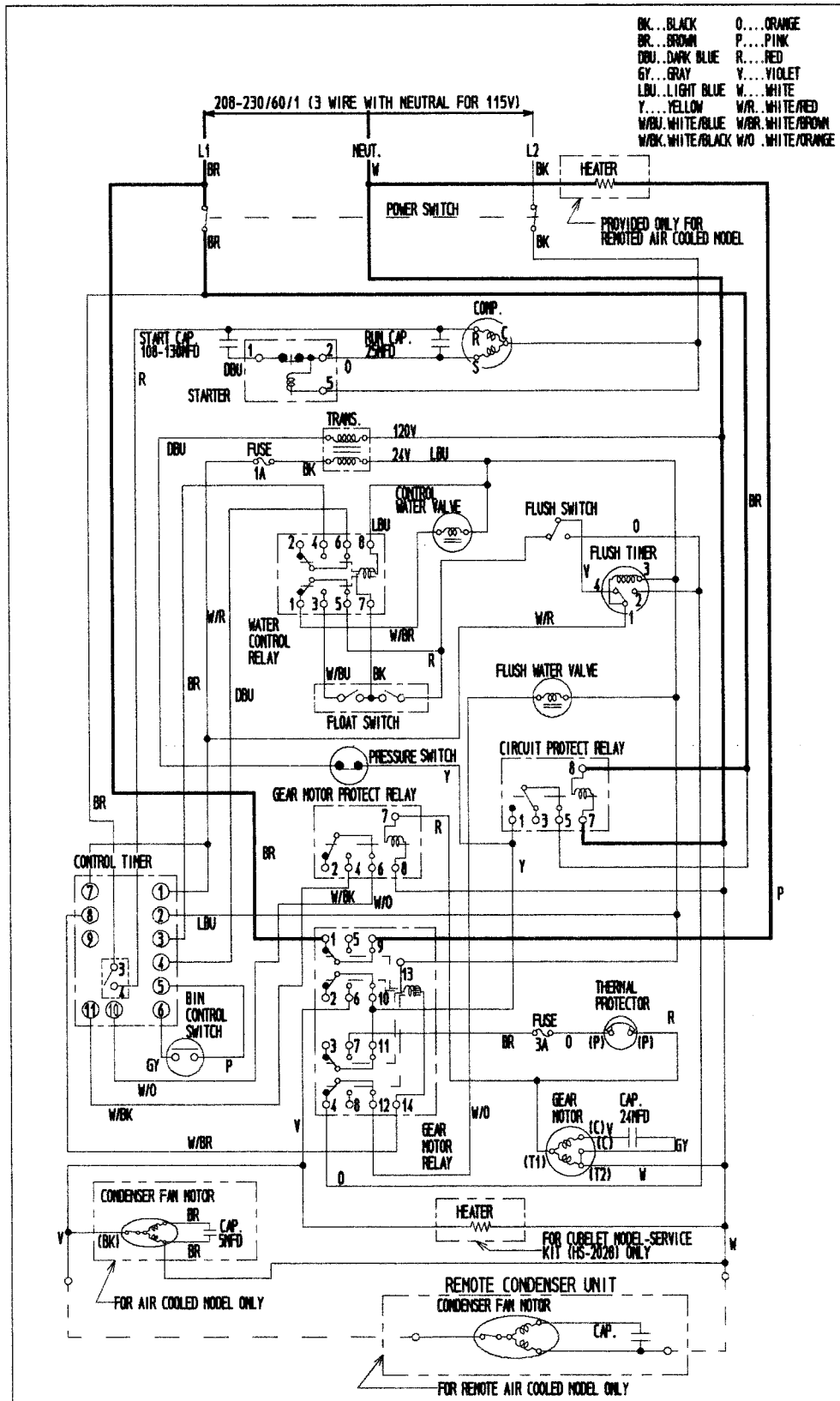

[ ] If Gear Motor Fuse (3A) blows, the Compressor and Gear Motor will turn off immediately.

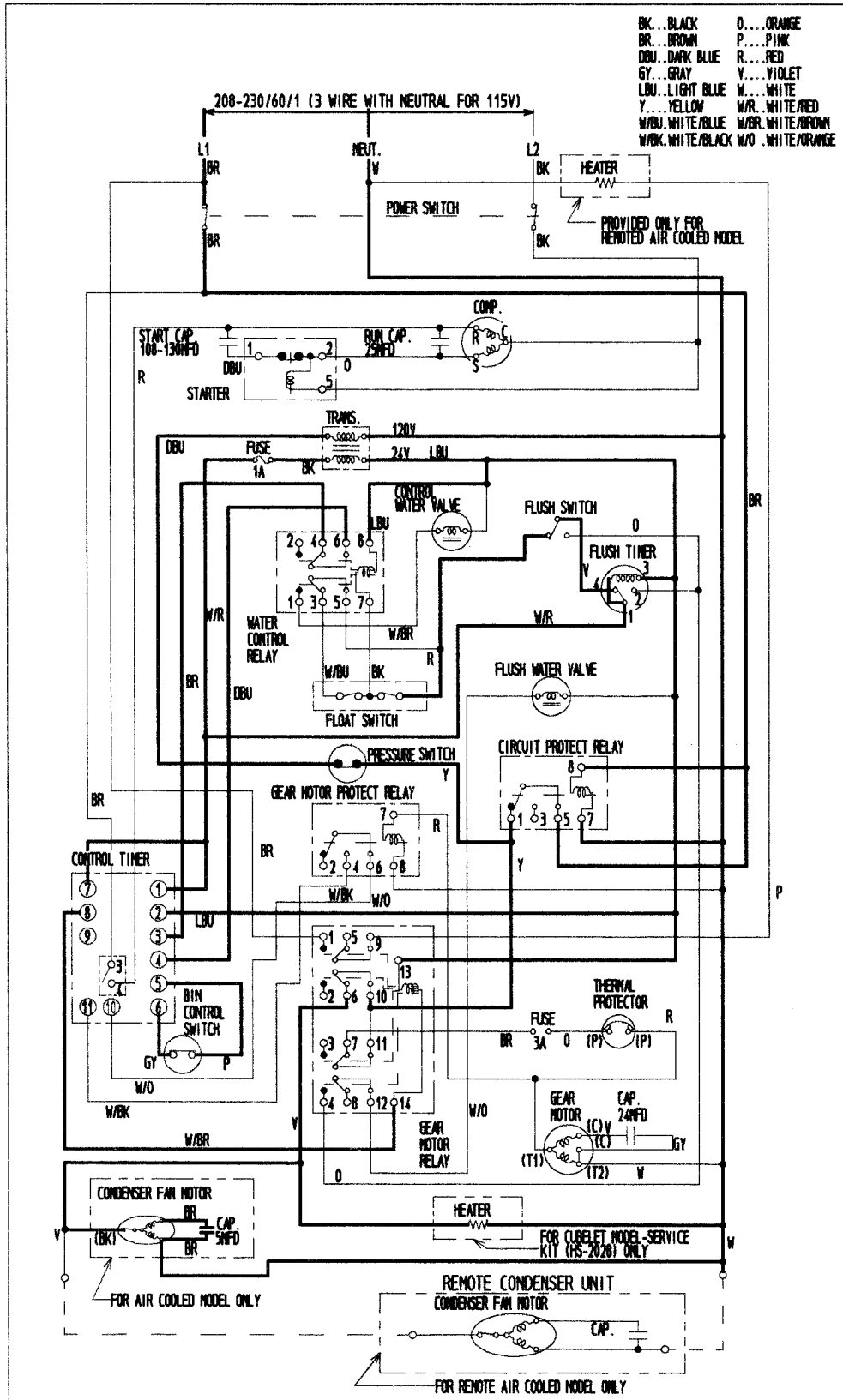

# 4. TIMING CHART

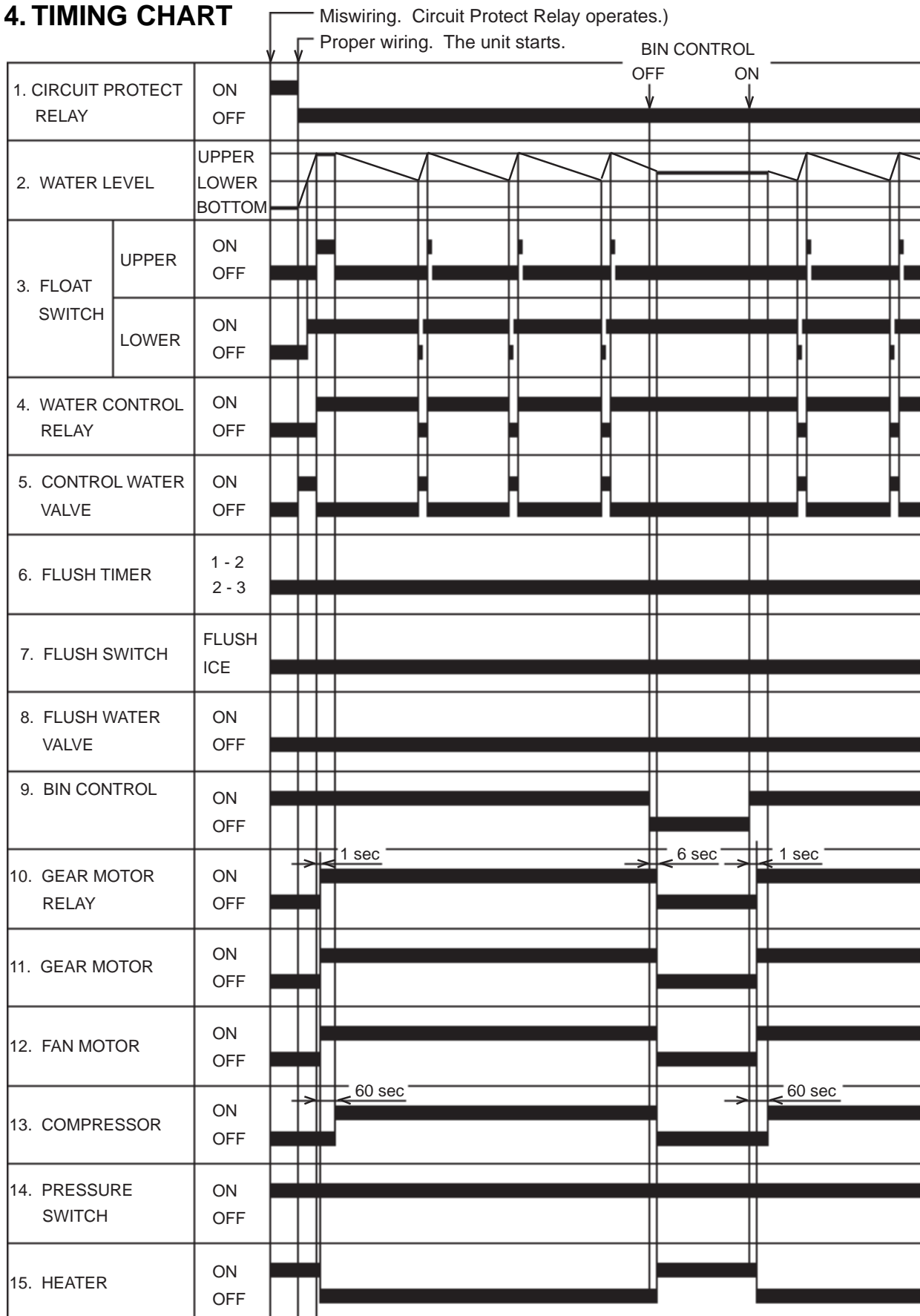

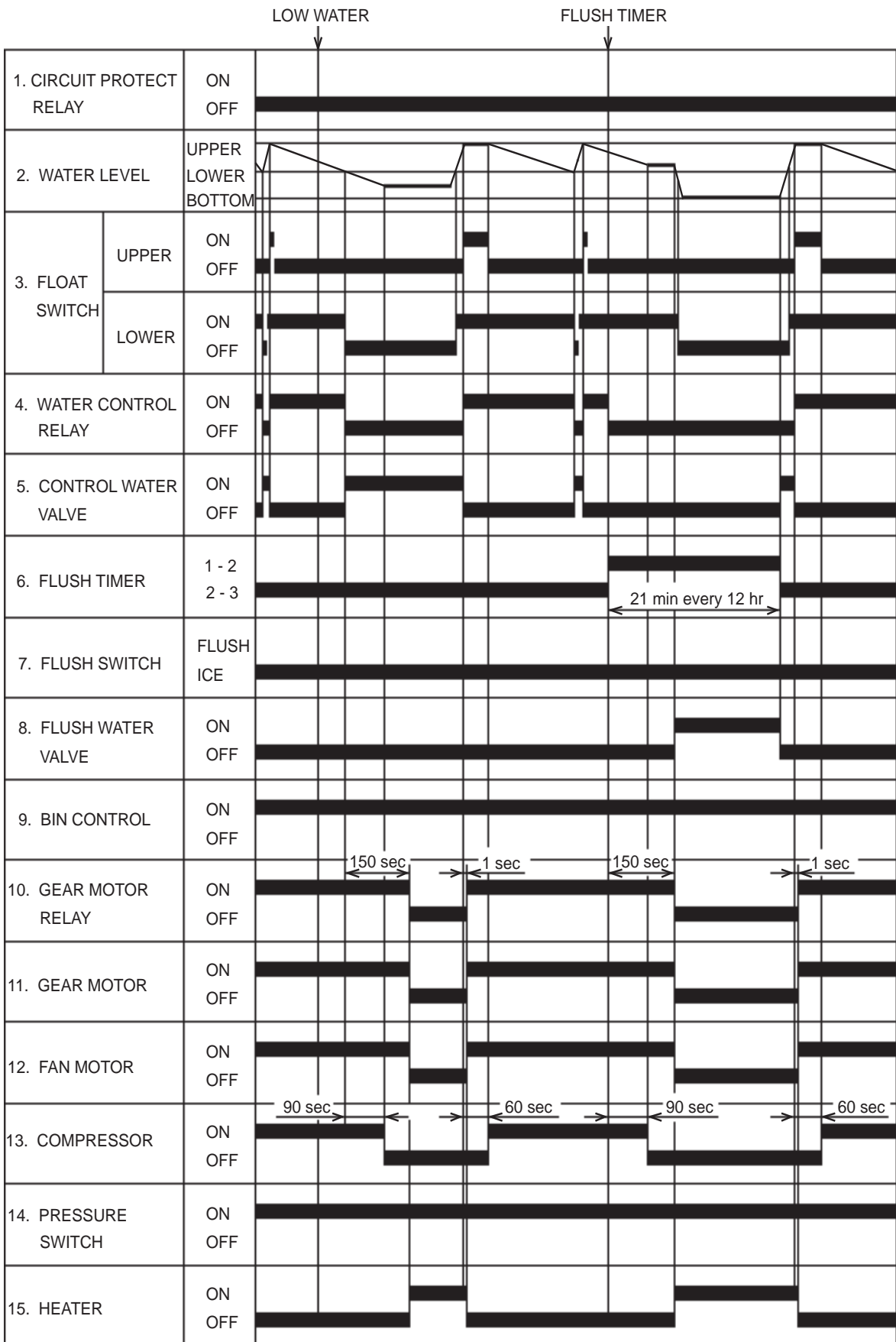

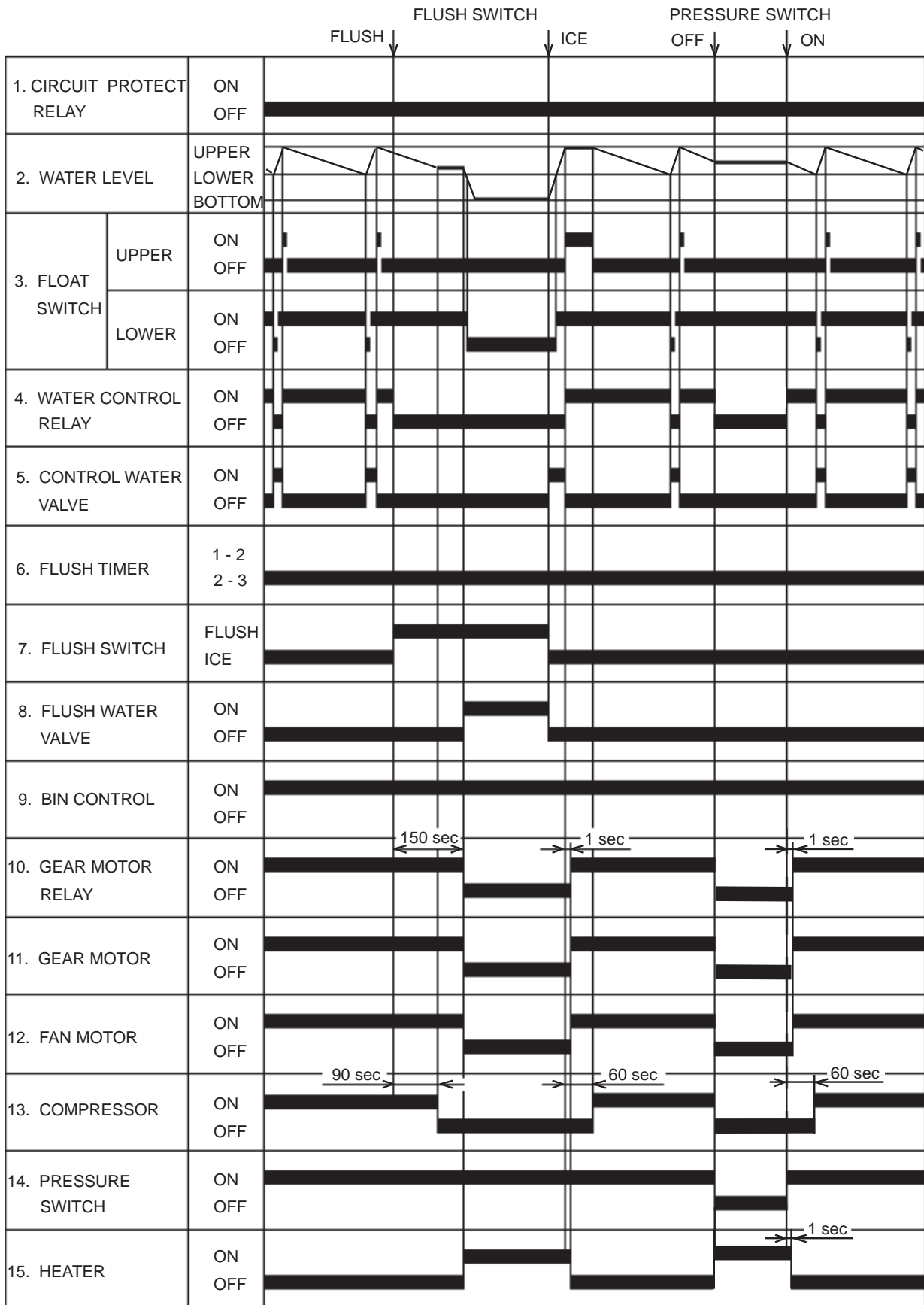



## **5. PERFORMANCE DATA**

**F-1001MAF**

**Data not yet available**

We reserve the right to make changes in specifications and design without prior notice.

**F-1001MWF**

**Data not yet available**

We reserve the right to make changes in specifications and design without prior notice.

**F-1001MRF**

**Data not yet available**

We reserve the right to make changes in specifications and design without prior notice.

**F-1001MLF**

**Data not yet available**

We reserve the right to make changes in specifications and design without prior notice.

**F-1001MAF-C**

**Data not yet available**

We reserve the right to make changes in specifications and design without prior notice.

**F-1001MWF-C**

**Data not yet available**

We reserve the right to make changes in specifications and design without prior notice.

**F-1001MRF-C**

**Data not yet available**

We reserve the right to make changes in specifications and design without prior notice.

**F-1001MLF-C**

**Data not yet available**

We reserve the right to make changes in specifications and design without prior notice.



## IV. ADJUSTMENT OF COMPONENTS

### 1. ADJUSTMENT OF WATER REGULATING VALVE - WATER-COOLED MODEL ONLY

The Water Regulating Valve also called “WATER REGULATOR” is factory-adjusted. No adjustment is required under normal use. Adjust the Water Regulator , if necessary, using the following procedures.

- 1) Attach a pressure gauge to the high-side line of the system. Or prepare a thermometer to check the condenser drain temperature.
- 2) Rotate the Adjustment Screw by using a flat blade screwdriver, so that the pressure gauge shows 260 PSIG (R-404A models/-F type), or the thermometer reads 100 -104°F, in 5 minutes after the icemaking process starts. When the pressure exceeds 260 PSIG, or the condenser drain temperature exceeds 104°F, rotate the Adjustment Screw counterclockwise.
- 3) Check that the pressure or the condenser drain temperature holds a stable setting.

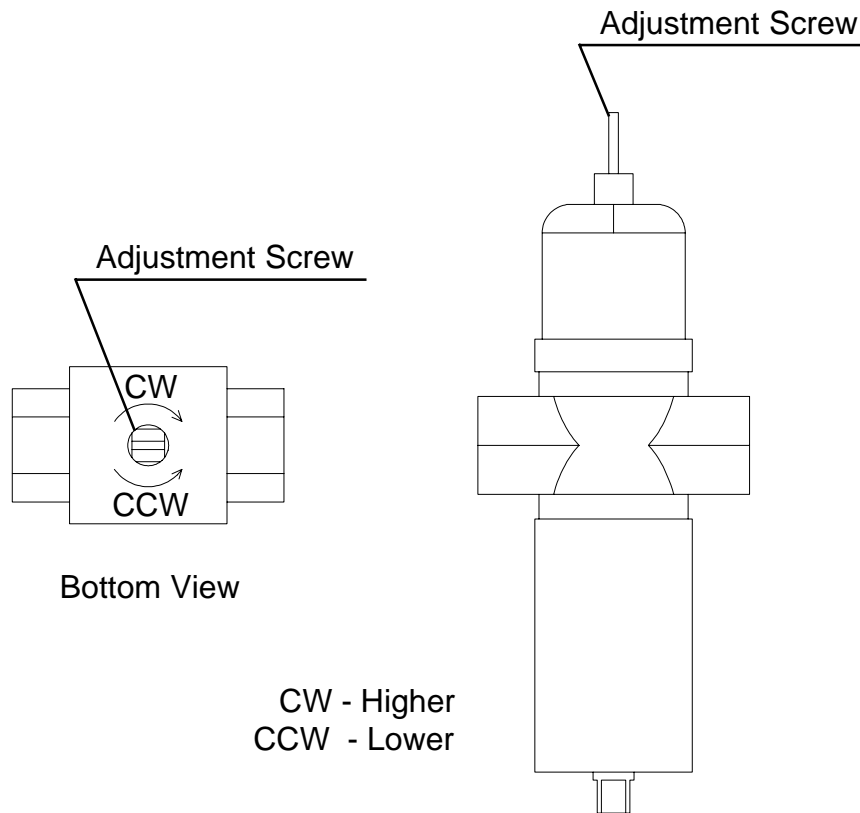

## V. SERVICE DIAGNOSIS

### 1. NO ICE PRODUCTION

PROBLEM	POSSIBLE CAUSE		REMEDY
[1] The icemaker will not start.	a) Power Supply	1. OFF position.	1. Move to ON position.
		2. Loose connection.	2. Tighten.
		3. Bad contacts.	3. Check for continuity and replace.
		4. Blown fuse.	4. Replace.
	b) Power Switch (Control Box)	1. Off position.	1. Move to ON position.
		2. Bad contacts.	2. Check for continuity and replace.
	c) Fuse (Control Box)	1. Blown out.	1. Check for short circuit and replace.
	d) Circuit Protect Relay	1. Miswiring.	1. Check power supply voltage and wire properly.
	e) Flush Timer	1. Flushing out.	1. Wait for 15 minutes.
		2. Bad contacts.	2. Check for continuity and replace.
	f) Flush Switch	1. FLUSH position.	1. Move to ICE position.
		2. Bad contacts.	2. Check for continuity and replace.
g) Transformer	1. Coil winding opened.	1. Replace.	
h) Control Water Valve	1. Coil winding opened.	1. Replace.	
i) Shut-off Valve	1. Closed.	1. Open.	
	2. Water failure.	2. Wait till water is supplied.	
j) Plug and Receptacle (Control Box)	1. Disconnected.	1. Connect.	
	2. Terminal out of Plug or Receptacle.	2. Insert Terminal back in position	
[2] Water flow does not stop, and the icemaker will not start	a) Water Control Relay	1. Contact fused.	1. Replace.
		2. Coil winding opened.	2. Replace.
	b) Float Switch	1. Bad contacts.	1. Check for continuity and replace.
		2. Float does not move freely.	2. Clean or replace.
c) Flush Water Valve	1. Valve seat clogged and water leaking.	1. Clean or replace	
d) Hoses	1. Disconnected.	1. Connect.	
[3] Water has been supplied, but the icemaker will not start.	a) Water Control Relay	1. Bad contacts.	1. Check for continuity and replace.
	b) Bin Control	1. Bad contacts.	1. Check for continuity and replace.
		2. Activator does not move freely.	2. Clean Axle and its corresponding holes or replace Bin Control.
	c) Gear Motor Relay	1. Coil winding opened.	1. Replace.
		2. bad contacts.	2. Check for continuity and replace.
	d) Control Timer (Printed Circuit Board)	1. Broken.	1. Replace.
e) Gear Motor Protect Relay	1. Coil winding opened.	1. Replace.	
	2. Bad contacts.	2. Check for continuity and replace.	

PROBLEM	POSSIBLE CAUSE		REMEDY
[4] Water has been supplied, Fan Motor starts, but Gear Motor and Compressor will not start.	a) Gear Motor Fuse (BUSSMAN GMD 3.0A)	1. Blown Fuse.	1. See "3. [3]." Find out the cause and replace the Fuse.
	b) Thermal Protector (Gear Motor)	1. Bad contacts.	1. Check for continuity and replace.
[5] Gear Motor and Compressor start but operate intermittently.	a) Pressure Switch	1. Dirty Air Filter or Condenser.	1. Clean.
		2. Ambient or condenser water temperature too warm.	2. Get cooler.
		3. Condenser water pressure too low or off. (Water-cooled model only)	3. Check and get recommended pressure.
		4. Water Regulating Valve set too high. (Water-cooled model only)	4. Adjust it lower.
		5. Fan not rotating.	5. See "3. [1] a) Fan Motor."
		6. Refrigerant overcharged.	6. Recharge.
		7. Refrigerant line or components plugged.	7. Clean and replace drier.
		8. Bad contacts.	8. Check for continuity and replace.
		9. Loose connections.	9. Tighten.
[6] Gear Motor starts, but Compressor will not start or operates intermittently.	a) X2 Relay on Control Timer	1. Bad contacts.	1. Replace. Check for continuity and replace.
		2. Coil winding opened.	2. Replace Timer.
	b) Starter	1. Bad contacts.	1. Check for continuity and replace.
		2. Coil winding opened.	2. Replace.
		3. Loose Connections.	3. Tighten.
	c) Start Capacitor or Run Capacitor	1. Defective.	1. Replace.
	d) Compressor	1. Loose connections.	1. Tighten.
		2. Motor winding opened or grounded.	2. Replace.
		3. Motor Protector tripped.	3. Find out the cause of overheat or overcurrent.
	e) Power Supply	1. Circuit Ampacity too low.	1. Install a larger-sized conductor.
[7] Gear Motor and Compressor start, but no ice is produced.	a) Refrigerant Line	1. Gas leaks.	1. Check for leaks with a leak detector. Reweld leak, replace drier and charge with refrigerant. The amount of refrigerant is marked on Nameplate or Label.
		2. Refrigerant line clogged.	2. Replace the clogged component.

## 2. LOW ICE PRODUCTION

PROBLEM	POSSIBLE CAUSE		REMEDY
[1] Low ice production	a) Refrigerant Line	1. Gas leaks.	1. See "1. [5] a) Refrigerant Line."
		2. Refrigerant line clogged.	2. Replace the clogged component.
		3. Overcharged.	3. Recharge.
	b) High-side Pressure Too High	1. Dirty Air Filter or Condenser.	1. Clean.
		2. Ambient or condenser water temperature too warm.	2. Get cooler.
		3. Condenser water pressure too low or off. [Water-cooled model only]	3. Check and get recommended pressure.
		4. Fan rotating too slow.	4. See "3 [1] a) Fan Motor."
		5. Water Regulating Valve clogged. [Water-cooled model only]	5. Clean.
		6. Condensing unit out of order.	6. Check condensing unit.
	c) Expansion Valve (not adjustable)	1. Low-side pressure too low.	1. Replace.
		2. Low-side pressure too high.	2. See if Expansion Valve Bulb is mounted properly, and replace the valve if necessary.

### 3. OTHERS

PROBLEM	POSSIBLE CAUSE		REMEDY
[1] Abnormal noise	a) Fan Motor	1. Bearing worn out.	1. Replace.
		2. Fan blade deformed.	2. Replace fan blade.
		3. Fan blade does not move freely.	3. Replace.
	b) Compressor	1. Bearings worn out, or cylinder valve broken.	1. Replace.
		2. Mounting pad out of position.	2. Reinstall.
	c) Refrigerant Lines	1. Rub or touch lines or other surfaces.	1. Replace.
	d) Gear Motor (Ice Making)	1. Bearing or Gear worn out / damaged.	1. Replace.
e) Evaporator	1. Too much pressure loss.	1. Replace.	
	2. Scale on inside wall of Freezing Cylinder.	2. Remove Auger. Use "SCALE AWAY" or "LIME-A-WAY" solution to clean periodically. If the water is found hard by testing, install a softener.	
[2] Overflow from Reservoir (Water does not stop.)	a) Water Supply	1. Water pressure too high.	1. Install a pressure Reducing Valve
	b) Control Water Valve	1. Diaphragm does not close.	1. Clean or replace.
	c) Float Switch	1. Bad contacts.	1. Check for continuity and replace.
[3] Gear Motor Fuse blown frequently.	a) Power Supply Voltage	1. Too high or too low.	1. Connect the unit to a power supply of proper voltage.
	b) Ice Making Unit	1. Bearings or Auger worn out.	1. Replace Bearing or Auger.
	c) Bin Control	1. Bad contacts.	1. Check for continuity and replace.
		2. Activator does not move freely.	2. Clean Axle and its corresponding holes or replace Bin Control.

## VI. REMOVAL AND REPLACEMENT OF COMPONENTS

### IMPORTANT

Ensure all components, fasteners and thumbscrews are securely in place after the equipment is serviced.

### IMPORTANT

1. The Polyol Ester (POE) oils used in R-404A units can absorb moisture quickly. Therefore it is important to prevent moisture from entering the system when replacing or servicing parts.
2. Always install a new filter drier every time the sealed refrigeration system is opened.
3. Do not leave the system open for longer than 15 minutes when replacing or servicing parts.

## 1. SERVICE FOR REFRIGERANT LINES

### [a] REFRIGERANT RECOVERY [EXCEPT F-1001MLF(-C)]

The icemaker unit is provided with two Refrigerant Access Valves - one on the low-side and one on the high-side line. Using proper refrigerant practices recover the refrigerant from the Access Valves and store it in an approved container. Do not discharge the refrigerant into the atmosphere.

### [b] REFRIGERANT RECOVERY [F-1001MLF ONLY]

The refrigerant charge on the F-1001MLF is provided from the external Compressor Rack Assembly. In the event that service is required on the F-1001MLF, close the Suction and Liquid Line Shut-off Valves located at the rear of the unit. Attach the Service Manifold Hoses to the High-side, Low-side and Evaporator Pressure Regulator (E.P.R.) access ports to purge or evacuate the unit. To recharge the system, simply open the Suction and Liquid Line Shut-off Valves after evacuating the F-1001MLF.

### [c] EVACUATION AND RECHARGE [R-404A]

- 1) Attach Charging Hoses, a Service Manifold and a Vacuum Pump to the system. Be sure to connect Charging Hoses to both High-side and Low-side Access Valves.

### IMPORTANT

The vacuum level and vacuum pump may be the same as those for current refrigerants. However, the rubber hose and gauge manifold to be used for evacuation and refrigerant charge should be exclusively for POE oils.

- 2) Turn on the Vacuum Pump. Never allow the oil in the Vacuum Pump to flow backward.
- 3) Allow the Vacuum Pump to pull down to a 29.9" Hg vacuum. Evacuating period depends on pump capacity.
- 4) Close the Low-side Valve and High-side Valve on the Service Manifold.
- 5) Disconnect the Vacuum Pump, and attach a Refrigerant Service Cylinder to the High-side line. Remember to loosen the connection, and purge the air from the Hose. See the Nameplate for the required refrigerant charge. Hoshizaki recommends only virgin refrigerant or reclaimed refrigerant which meets ARI Standard No. 700-88 be used.
- 6) A liquid charge is recommended for charging an R-404A system. Invert the Service Cylinder. Open the High-side, service manifold Valve.
- 7) Allow the system to charge with liquid until the pressures balance.
- 8) If necessary, add any remaining charge to the system through the Low-side. Use a throttling valve or liquid dispensing device to add the remaining liquid charge through the Low-side access port with the unit running.
- 9) Close the two Refrigerant Access Valves, and disconnect the Hoses and Service Manifold.
- 10) Cap the Access Valves to prevent a possible leak.

## 2. BRAZING

### **DANGER**

1. Refrigerant R-404A itself is not flammable at atmospheric pressure and temperatures up to 176° F.
2. Refrigerant R-404A itself is not explosive or poisonous. However, when exposed to high temperatures (open flames) R-404A can be decomposed to form hydrofluoric acid and carbonyl fluoride both of which are hazardous.
3. Always recover the refrigerant and store it in an approved container. Do not discharge the refrigerant into the atmosphere.
4. Do not use silver alloy or copper alloy containing Arsenic.
5. Do not use R-404A as a mixture with pressurized air for leak testing. Refrigerant leaks can be detected by charging the unit with a little refrigerant, raising the pressure with nitrogen and using an electronic leak detector.

### 3. REMOVAL AND REPLACEMENT OF COMPRESSOR

#### IMPORTANT

Always install a new Drier every time the sealed refrigeration system is opened. Do not replace the Drier until after all other repairs or replacement have been made.

- 1) Turn off the power supply, and remove the panels.
- 2) Remove the Terminal Cover on the Compressor, and disconnect the Compressor Wiring.
- 3) Recover the refrigerant and store it in an approved container, if required by an applicable law.
- 4) Remove the Discharge, Suction and Access Pipes from the Compressor using brazing equipment.

#### WARNING

When repairing a refrigerant system, be careful not to let the burner flame contact any electrical wires or insulation.

- 5) Remove the Bolts and Rubber Grommets.
- 6) Slide and remove the Compressor. Unpack the new Compressor package. Install the new Compressor.
- 7) Attach the Rubber Grommets of the prior Compressor.
- 8) Sandpaper the Discharge, Suction and Access Pipes.
- 9) Place the Compressor in position, and secure it using the Bolts.
- 10) Remove plugs from the Discharge, Suction and Access Pipes.
- 11) Braze the Access, Suction and Discharge lines (Do not change this order), while purging with nitrogen gas flowing at the pressure of 3-4 PSIG.
- 12) Install the new Drier.
- 13) Check for leaks using nitrogen gas (140 PSIG) and soap bubbles.



- 14) Evacuate the system, and charge it with refrigerant. For the air-cooled and water-cooled models, see the Nameplate for the required refrigerant charge and type. For the remote air-cooled models, see the label on the Control Box.
- 15) Connect the Terminals to the Compressor, and replace the Terminal Cover in its correct position.
- 16) Replace the panels in their correct position, and turn on the power supply.

#### 4. REMOVAL AND REPLACEMENT OF DRIER

##### **IMPORTANT**

Always install a new Drier every time the sealed refrigeration system is opened. Do not replace the Drier until after all other repairs or replacement have been made.

- 1) Turn off the power supply, and remove the panels.
- 2) Recover the refrigerant and store it in an approved container, if required by an applicable law.
- 3) Remove the Drier using brazing equipment.
- 4) Install the new Drier with the arrow on the Drier in the direction of the refrigerant flow. Use nitrogen gas at the pressure of 3-4 PSIG when brazing the tubings.
- 5) Check for leaks using nitrogen gas (140 PSIG) and soap bubbles.
- 6) Evacuate the system, and charge it with refrigerant. For the air-cooled and water-cooled models, see the Nameplate for the required refrigerant charge and type. For the remote air-cooled models, see the label on the Control Box.
- 7) Replace the panels in their correct position, and turn on the power supply.

## 5. REMOVAL AND REPLACEMENT OF EXPANSION VALVE

### IMPORTANT

Sometimes moisture in the refrigerant circuit exceeds the Drier capacity and freezes up at the Expansion Valve. Always install a new Drier every time the sealed refrigeration system is opened. Do not replace the Drier until after all other repairs or replacement have been made.

- 1) Turn off the power supply, and remove the panels.
- 2) Recover the refrigerant and store it in an approved container, if required by an applicable law.
- 3) Remove the Expansion Valve Bulb at the Evaporator outlet.
- 4) Remove the Expansion Valve Cover, and remove the Expansion Valve using brazing equipment.
- 5) Braze the new Expansion Valve with nitrogen gas flowing at the pressure of 3-4 PSIG.

### WARNING

Always protect the valve body by using a damp cloth to prevent the valve from overheating. Do not braze with the valve body exceeding 250°F.

- 6) Install the new Drier.
- 7) Check for leaks using nitrogen gas (140 PSIG) and soap bubbles.
- 8) Evacuate the system. Charge it with refrigerant. For the air-cooled and water-cooled models, see the Nameplate for the required refrigerant charge and type. For the remote air-cooled models, see the label on the Control Box.
- 9) Attach the Bulb to the suction line. Be sure to secure the Bulb using a band and to insulate it.
- 10) Place the new set of Expansion Valve Covers in position.
- 11) Replace the panels in their correct position, and turn on the power supply.

## 6. REMOVAL AND REPLACEMENT OF WATER REGULATING VALVE - WATER-COOLED MODEL ONLY

### IMPORTANT

Always install a new Drier every time the sealed refrigeration system is opened. Do not replace the Drier until after all other repairs or replacement have been made.

- 1) Turn off the power supply, remove the panels and close the Water Supply Line Shut-off Valve.
- 2) Recover the refrigerant and store it in an approved container.
- 3) Disconnect the Capillary Tube using brazing equipment.
- 4) Disconnect the Flare-connections of the valve.
- 5) Remove the screws and the valve from the Bracket.
- 6) Install the new valve, and braze the Capillary Tube.
- 7) Install the new Drier.
- 8) Check for leaks using nitrogen gas (140 PSIG) and soap bubbles.
- 9) Connect the Flare-connections.
- 10) Evacuate the system, and charge it with refrigerant. See the Nameplate for the required refrigerant charge and type.
- 11) Open the Water Supply Line Shut-off Valve, and turn on the power supply.
- 12) Check for water leaks.
- 13) See "IV. 1. ADJUSTMENT OF WATER REGULATING VALVE." If necessary, adjust the valve.
- 14) Replace the panels in their correct position.

## 7. REMOVAL AND REPLACEMENT OF CONDENSING PRESSURE REGULATOR (C.P.R.) - REMOTE AIR-COOLED MODEL ONLY

### IMPORTANT

Always install a new Drier every time the sealed refrigeration system is opened. Do not replace the Drier until after all other repairs or replacement have been made.

- 1) Turn off the power supply.
- 2) Remove the panels from the remote condenser unit.
- 3) Recover the refrigerant and store it in an approved container.
- 4) Remove the C.P.R. using brazing equipment.
- 5) Braze the new C.P.R. with nitrogen gas flowing at the pressure of 3 - 4 PSIG.

### WARNING

Always protect the C.P.R. body by using a damp cloth to prevent the C.P.R. from overheating. Do not braze with the C.P.R. body exceeding 250°F.

- 6) Install the new Drier in the icemaker.
- 7) Check for leaks using nitrogen gas (140 PSIG) and soap bubbles.
- 8) Evacuate the system and charge it with refrigerant. See the label on the Control Box in the icemaker.
- 9) Replace the panels in their correct position.
- 10) Turn on the power supply.

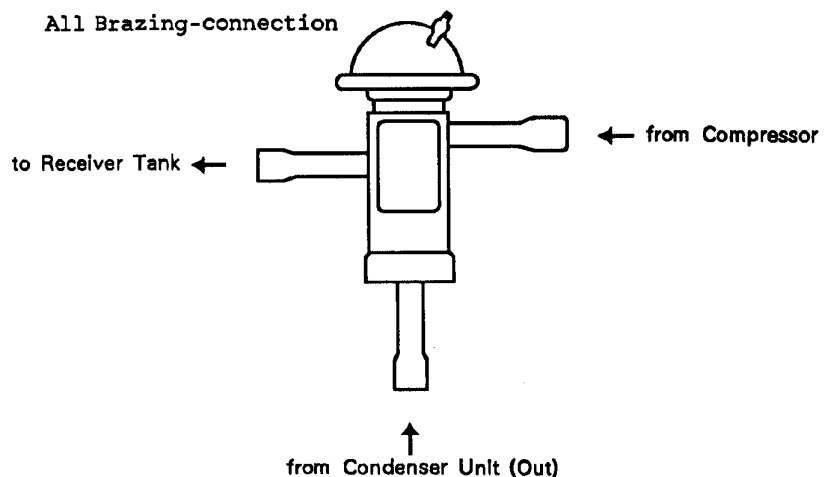

## **8. REMOVAL AND REPLACEMENT OF EVAPORATOR ASSEMBLY**

- 1) Turn off the power supply.
- 2) Remove the panels.
- 3) Move the Flush Switch to the "FLUSH" position.
- 4) Turn on the power supply and drain out all water from the water line.
- 5) Turn off the power supply.
- 6) Remove the Band connecting the Spout with the Chute Assembly.
- 7) Remove the three Thumbscrews and take off the Spout from the Evaporator.

### **CUTTER**

- 8) Remove the Bolt and lift off the Cutter.
- 9) Remove the Rubber O-ring and the Nylon Ring at the top of the Evaporator.

### **EXTRUDING HEAD**

- 10) Remove the four Socket Head Cap Screws and lift off the Extruding Head.
- 11) Replace the Bearing inside the Extruding Head, if it exceeds the wear tolerance of 0.02" or is scratched.

Note: Replacing the Bearing requires a bearing press adaptor. If it is not available, replace the whole Extruding Head.

### **AUGER**

- 12) Lift off the Auger. If the area in contact with the Bearing is worn out or the Blade scratched, replace the Auger.

### **EVAPORATOR**

Note: Skip the following steps 13) through 15) when the Evaporator does not need replacement.

- 13) Recover the refrigerant and store it in an approved container, if required by an applicable law.

### **IMPORTANT**

Always install a new Drier every time the sealed refrigeration system is opened. Do not replace the Drier until after all other repairs or replacement have been made.

- 14) Remove the Bulb of the Expansion Valve.
- 15) Disconnect the brazing-connections of the Expansion Valve and the Copper Tube - Low Side from the Evaporator, using brazing equipment.
- 16) Remove the two Truss Head Machine Screws and the Strap securing the Evaporator.
- 17) Disconnect the three Hoses from the Evaporator.
- 18) Remove the four Socket Head Cap Screws securing the Evaporator with the Bearing-Lower.
- 19) Lift off the Evaporator.

### **BEARING-LOWER AND MECHANICAL SEAL**

- 20) The Mechanical Seal consists of two parts. One moves along with the Auger, and the other is fixed on the Bearing-Lower. If the contact surfaces of these two parts are worn or scratched, the Mechanical Seal may cause water leaks and should be replaced.
- 21) Remove the O-ring on the Bearing-Lower.
- 22) Remove the four Bolts and the Bearing-Lower from the Gear Motor. Replace the Bearing inside the Bearing-Lower, if it exceeds the wear tolerance of 0.02" or is scratched.

Note: Replacing the Bearing requires a bearing press adaptor. If it is not available, replace the whole Bearing-Lower.

### **GEAR MOTOR**

- 23) Remove the Coupling-Spline on the Gear Motor Shaft.
- 24) Remove the Barrier on the top of the Gear Motor.

25) Remove the three Socket Head Cap Screws securing the Gear Motor.

26) Assemble the removed parts in the reverse order of the above procedure.

**WARNING**

Be careful not to scratch the surface of the O-ring, or it may cause water leaks. Handle the Mechanical Seal with care not to scratch nor to contaminate its contact surface.

27) When replacing the Evaporator;

(a) Braze the new Evaporator with nitrogen gas flowing at the pressure of 3-4 PSIG.

(b) Replace the Drier.

(c) Check for leaks using nitrogen gas (140 PSIG) and soap bubbles.

(d) Evacuate the system. Charge it with refrigerant. For the air-cooled and water-cooled models, see the Nameplate for required refrigerant charge and type. For the remote air-cooled models, see the label on the Control Box.

28) Move the Flush Switch to the "ICE" position.

29) Replace the panels in their correct position.

30) Turn on the power supply.

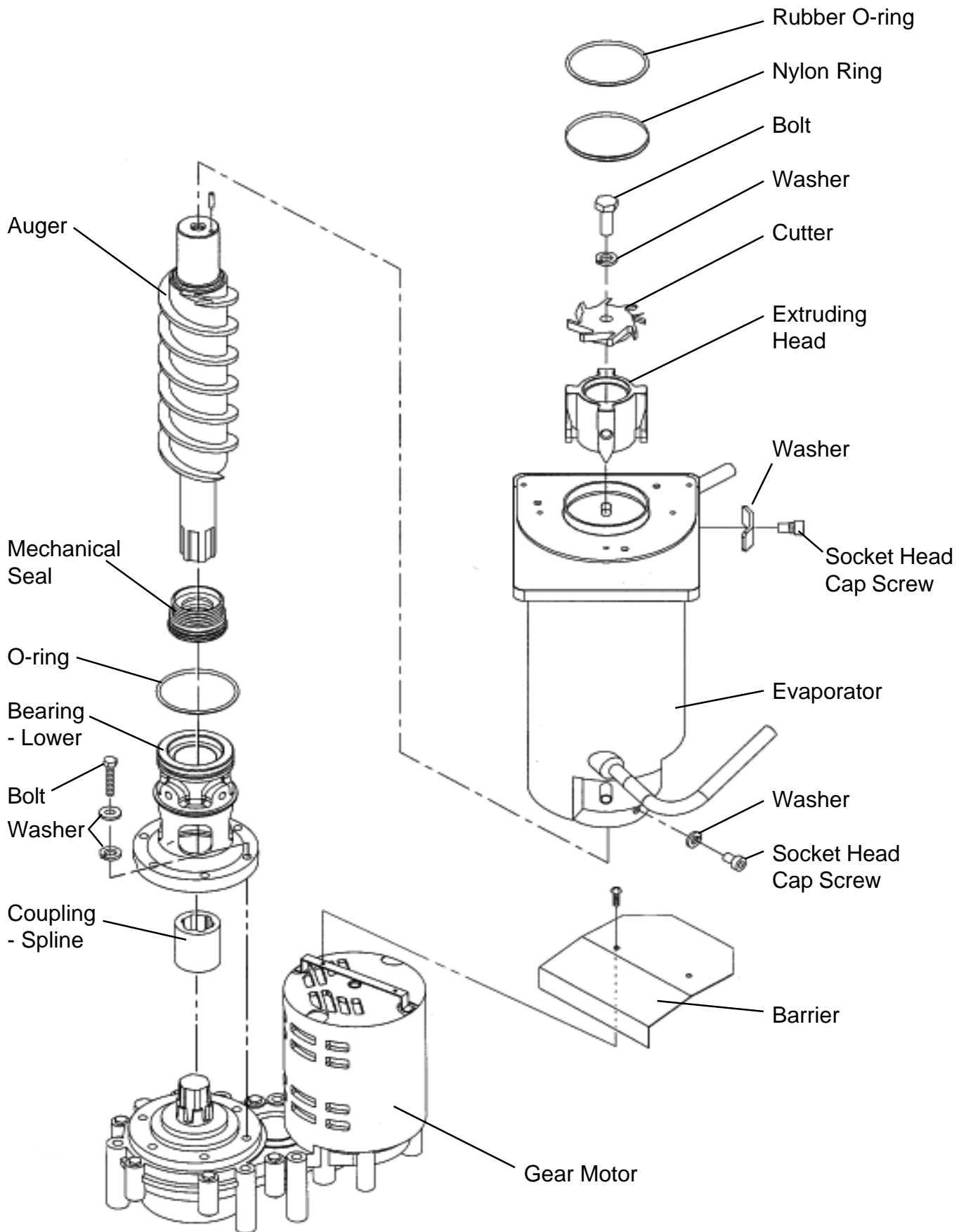



## **9. REMOVAL AND REPLACEMENT OF FAN MOTOR**

- 1) Turn off the power supply and remove the panels.
- 2) Remove the wire connectors from the Fan Motor leads.
- 3) Remove the Fan Motor Bracket and Fan Motor.
- 4) Install the new Fan Motor.
- 5) Replace the Fan Motor Bracket and the wire connectors.
- 6) Replace the panels in their correct position, and turn on the power supply.

## **10. REMOVAL AND REPLACEMENT OF CONTROL WATER VALVE**

- 1) Turn off the power supply, remove the panels and close the Water Supply Line Shut-off Valve.
- 2) Disconnect the Terminals from the Control Water Valve.
- 3) Loosen the Fitting Nut on the Control Water Valve Inlets, and remove the Control Water Valve. Do not lose the Packings inside the Fitting Nut.
- 4) Remove the Water Supply Hose from the Control Water Valve.
- 5) Install the new Control Water Valve.
- 6) Assemble the removed parts in the reverse order of the above procedure.
- 7) Open the Water Supply Line Shut-off Valve.
- 8) Check for water leaks.
- 9) Replace the panels in their correct position, and turn on the power supply.

## **11. REMOVAL AND REPLACEMENT OF FLUSH WATER VALVE**

- 1) Turn off the power supply, remove the panels and close the Water Supply Line Shut-off Valve.
- 2) Remove the Clamp and disconnect the Hose from the Flush Water Valve.

Note: Water may still remain inside the Evaporator. Be sure to drain the water into the Drain Pan.

- 3) Disconnect the Terminals from the Flush Water Valve.
- 4) Remove the Flush Water Valve from the Bracket.
- 5) Remove the Drain Pipe from the Flush Water Valve.
- 6) Connect the Drain Pipe to the new Flush Water Valve, and place the valve in position.
- 7) Connect the Hose to the Flush Water Valve and secure it with the Clamp.
- 8) Pour water into the Reservoir, and check for water leaks on the Flush Water Valve.
- 9) Open the Water Supply Line Shut-off Valve, and turn on the power supply.
- 10) Move the Flush Switch to the "ICE" position.
- 11) Check for water leaks.
- 12) Move the Flush Switch to the "FLUSH" position, and make sure water is flushing.
- 13) Move the Flush Switch to the "ICE" position.
- 14) Replace the panels in their correct position.

## VII. MAINTENANCE AND CLEANING INSTRUCTIONS

### IMPORTANT

Ensure all components, fasteners and thumbscrews are securely in place after any maintenance or cleaning is done to the equipment.

### 1. PREPARING THE ICEMAKER FOR LONG STORAGE

#### WARNING

When shutting off the icemaker for an extended time, drain out all water from the water line and remove the ice from the Storage Bin. The Storage Bin should be cleaned and dried. Drain the icemaker to prevent damage to the water supply line at sub-freezing temperatures, using air or carbon dioxide. Shut off the icemaker until the proper ambient temperature is resumed.

[Air-cooled and Remote Air-cooled Models]

- 1) Run the icemaker with the Water Supply Line Shut-off Valve closed.
- 2) Open the Drain Valve and blow out the water inlet line by using air pressure.
- 3) Turn off the power supply.
- 4) Remove the Front Panel.
- 5) Move the Flush Switch on the Control Box to the "FLUSH" position.
- 6) Turn on the power supply, and then drain out all water from the water line.
- 7) Turn off the power supply.
- 8) Turn off the Power Switch on the Control Box.
- 9) Replace the Front Panel in its correct position.
- 10) Close the Drain Valve.
- 11) Remove all ice from the Storage Bin, and clean the bin.

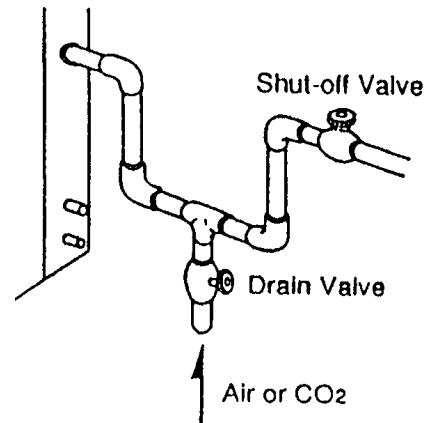

[Water-cooled Models]

- 1) Turn off the power supply and wait for 3 minutes.
- 2) Turn on the power supply and wait for 20 seconds.
- 3) Close the Water Supply Line Shut-off Valve.
- 4) Open the Drain Valve and quickly blow the water supply line from the Drain Valve to drain water in the Condenser.
- 5) Follow the above steps 3) through 11) in [Air-cooled and Remote Air-cooled Models].

## 2. CLEANING INSTRUCTIONS

### IMPORTANT

Ensure all components, fasteners and thumbscrews are securely in place after any maintenance or cleaning is done to the equipment.

### WARNING

1. HOSHIZAKI recommends cleaning this unit at least once a year. More frequent cleaning, however, may be required in some existing water conditions.
2. To prevent injury to individuals and damage to the icemaker, do not use ammonia type cleaners.
3. Always wear liquid-proof gloves for safe handling of the cleaning and sanitizing solution. This will prevent irritation in case the solution comes into contact with skin.

#### <STEP 1>

Dilute the solutions with water as follows.

Cleaning solution: 4.8 fl. oz. of recommended cleaner Hoshizaki "Scale Away" or "LIME-A-WAY" (Economics Laboratory, Inc.) with 0.8 gal. of water. This is a minimum amount. Make more solution, if necessary.

Sanitizing solution: 2.5 fl. oz. of a 5.25% sodium hypochlorite solution (chlorine bleach) with 5 gal. of water.

### IMPORTANT

For safety and maximum effectiveness, use the solution immediately after dilution.

#### <STEP 2>

Use the cleaning solution to remove lime deposits in the water system.

- 1) Turn off the power supply.
- 2) Close the Water Supply Line Shut-off Valve.
- 3) Remove all ice from the Storage Bin.
- 4) Remove the Front Panel and the Top Panel.
- 5) Move the Flush Switch to the "FLUSH" position.

- 6) Turn on the power supply and drain out all water from the water line.
- 7) Turn off the power supply.
- 8) Remove the Control Water Valve by releasing the Fitting Nut. Do not lose the Packing.
- 9) Remove the Cover of the Reservoir.
- 10) Fill the Reservoir with the cleaning solution.
- 11) Replace the Cover of the Reservoir and the Control Water Valve in their correct position.

Note: This unit is designed to start operating when the Reservoir is filled with water.

- 12) Move the Flush Switch to the "ICE" position.
- 13) Replace the Top Panel and the Front Panel in their correct position.
- 14) Allow the icemaker to set for about 10 minutes before the operation. Then, turn on the power supply, and make ice using the solution until the icemaker stops icemaking.
- 15) Remove the Front Panel.
- 16) Move the Flush Switch to the "FLUSH" position to drain the cleaning solution.
- 17) Move the Flush Switch to the "ICE" position.
- 18) Replace the Front Panel in its correct position.
- 19) Open the Water Supply Line Shut-off Valve, and supply water to the Reservoir.
- 20) Turn off the power supply when the Gear Motor starts.
- 21) Drain out all water from the water line. See 4) through 7).

### <STEP 3>

Use 3/4 gal. of the sanitizing solution to sanitize the icemaker.

- 1) Close the Water Supply Line Shut-off Valve.
- 2) Remove the Control Water Valve by releasing the Fitting Nut.
- 3) Remove the Cover of the Reservoir.
- 4) Fill the Reservoir with the sanitizing solution.

- 5) Replace the Cover of the Reservoir and the Control Water Valve in their correct position.
- 6) Move the Flush Switch to the "ICE" position.
- 7) Replace the Top Panel and the Front Panel in their correct position.
- 8) Allow the icemaker to set for about 10 minutes before the operation. Then, turn on the power supply, and make ice using the solution until the icemaker stops icemaking.
- 9) Remove the Front Panel.
- 10) Move the Flush Switch to the "FLUSH" position to drain the sanitizing solution.
- 11) Move the Flush Switch to the "ICE" position.
- 12) Replace the Front Panel in its correct position.
- 13) Open the Water Supply Line Shut-off Valve, and supply water to the Reservoir.
- 14) Turn off the power supply when the Gear Motor starts.
- 15) Drain out all water from the water line. See 4) through 7) in STEP 2.
- 16) Move the Flush Switch to the "ICE" position.

<STEP 4>

Use the sanitizing solution to sanitize removed parts.

- 1) Remove the Thumbscrew securing the Bin Control Switch on the Chute Assembly.
- 2) Remove the Band connecting the Spout with the Chute Assembly, and take out the Chute Assembly from the icemaker.
- 3) Remove the Gasket at the bottom of the Ice Chute and another at the Spout.
- 4) Remove the three Ties and the Insulation of the Chute.
- 5) Remove the six Wing Nuts and two Baffles.

**IMPORTANT**

When installing the Baffles, make sure that the bent surface (the one without the studs) faces the Activator so that the bent surface can guide the ice to the center of the Activator.

- 6) Remove the two Thumbscrews, Plate, and Gasket at the top of the Ice Chute, and then remove the Bin Control Assembly by sliding it slightly toward the Spout and lifting it off.
- 7) Disassemble the Bin Control Assembly by removing the two Snap Pins, Shaft and Activator.
- 8) Remove the three Thumbscrews and the Spout.
- 9) Remove the Rubber O-ring and Nylon Ring at the top of the Cylinder.
- 10) Soak or wipe the removed parts.
- 11) Rinse these parts thoroughly.

**IMPORTANT**

If the solution is left on these parts, they will rust.

- 12) Replace the removed parts and the panels.
- 13) Turn on the power supply and run the icemaker.
- 14) Turn off the power supply after 30 minutes.
- 15) Pour warm water into the Storage Bin to melt all ice, and then clean the Bin Liner with the solution.
- 16) Flush out any solution from the Storage Bin.
- 17) Turn on the power supply and start the automatic icemaking process.

**IMPORTANT**

1. After cleaning, do not use ice made from the sanitizing solution. Be careful not to leave any solution in the Storage Bin.
2. Follow carefully any instructions provided with the bottles of cleaning or sanitizing solution.
3. Never run the icemaker when the Reservoir is empty.



### 3. MAINTENANCE

#### IMPORTANT

1. This icemaker must be maintained individually, referring to the instruction manual and labels provided with the icemaker.
2. To have the optimum performance of this icemaker, the following consumable parts need periodic inspection, maintenance and replacement:

Extruding Head  
Housing  
Gear Motor  
Auger  
Mechanical Seal

These parts should be inspected at least once a year or every 10,000 hours of operation. Their service life, however, depends on water quality and environment. More frequent inspection and maintenance are recommended.

Consult with your local distributor about inspection and maintenance service. To obtain the name and phone number of your local distributor, call Hoshizaki Technical Support at 1-800-233-1940.

#### 1) Stainless Steel Exterior

To prevent corrosion, wipe the exterior occasionally with a clean and soft cloth. Use a damp cloth containing a neutral cleaner to wipe off oil or dirt build up.

#### 2) Storage Bin and Scoop

- Wash your hands before removing ice. Use the plastic scoop provided (Bin accessory).
- The Storage Bin is for ice use only. Do not store anything else in the bin.
- Keep the scoop clean. Clean using a neutral cleaner and rinse thoroughly.
- Clean the bin liner using a neutral cleaner. Rinse thoroughly after cleaning. Wash your hands before removing ice. Use the plastic scoop provided (Bin accessory).

### 3) Air Filter (Air-cooled model only)

A plastic mesh air filter removes dirt or dust from the air, and keeps the Condenser from getting clogged. As the filter gets clogged, the icemaker's performance will be reduced. Check the filter at least twice a month. When clogged, use warm water and a neutral cleaner to wash the filter.

### 4) Condenser (Except water-cooled model)

Check the Condenser once a year, and clean if required by using a brush or vacuum cleaner. More frequent cleaning may be required depending on the location of the icemaker.