

Hoshizaki America, Inc.

Modular Flaker

Models

F-1001MAH(-C)(-22C)

F-1001MWH(-C)

F-1001MRH(-C)

F-1001MLH(-C)



“A Superior Degree
of Reliability”

www.hoshizaki.com

PARTS LIST



Number: 71196
Issued: 10-29-2001
Revised: 2-3-2016

CONTENTS

Auxiliary Codes.....	3
Note About Ordering Parts	5
A. Main Assembly & Refrigeration Circuit	6
F-1001MAH(-C)	6
F-1001MWH(-C)	9
F-1001MRH(-C)	12
F-1001MLH(-C).....	15
B. Icemaking Unit	18
C. Water Circuit.....	20
D. Control Box Assembly.....	22
E. Accessories & Labels	24

Auxiliary Codes

F-1001MAH

L-0 March 2001
M-0 December 2001
N-0 December 2002
N-1 May 2003
P-0 December 2003
P-1 June 2004
Q-0 December 2004
R-0 December 2005
S-0 January 2007
T-0 January 2008
T-1 August 2008
U-0 January 2009
V-0 January 2010
V-1 May 2010
V-2 October 2010
V-3 November 2010
A-0 January 2011
B-0 January 2012
B-1 March 2012
C-0 January 2013
C-1 June 2013
C-2 September 2013
D-0 January 2014

F-1001MAH-C

L-0 April 2001
M-0 November 2002
N-0 February 2003
N-1 July 2003
P-0 December 2003
P-1 June 2004
Q-0 January 2005
R-0 December 2005
S-0 January 2007
T-0 January 2008
T-1 November 2008
U-0 February 2009
V-0 January 2010
V-1 May 2010
V-2 October 2010
V-3 November 2010
A-0 January 2011
B-0 January 2012
B-1 March 2012
C-0 January 2013
C-1 June 2013
C-2 September 2013
D-0 January 2014

F-1001MWH

L-0 March 2001
M-0 January 2002
M-1 April 2002
N-0 December 2002
N-1 May 2003
P-0 December 2003
Q-0 December 2004
R-0 January 2006
S-0 January 2007
T-0 January 2008
T-1 August 2008
U-0 January 2009
V-0 February 2010
V-1 May 2010
V-2 October 2010
V-3 November 2010
A-0 February 2011
B-0 January 2012
B-1 March 2012
C-0 January 2013
C-1 June 2013
C-2 September 2013
D-0 January 2014

F-1001MRH

L-0 May 2001
M-0 December 2001
N-0 December 2002
N-1 June 2003
P-0 January 2004
Q-0 December 2004
R-0 December 2005
S-0 January 2007
T-0 January 2008
T-1 August 2008
U-0 January 2009
V-0 January 2010
V-1 May 2010
V-2 October 2010
V-3 December 2010
A-0 January 2011
B-0 January 2012
B-1 March 2012
C-0 January 2013
C-1 June 2013
C-2 September 2013
D-0 January 2014

F-1001MWH-C

L-0 June 2001
M-0 March 2002
M-1 April 2002
N-0 January 2003
N-1 May 2003
P-0 April 2004
Q-0 January 2005
R-0 January 2006
S-0 January 2007
T-0 January 2008
U-0 February 2009
V-0 January 2010
V-1 May 2010
V-2 October 2010
V-3 November 2010
A-0 January 2011
B-0 January 2012
B-1 March 2012
C-0 January 2013
C-1 June 2013
C-2 September 2013
D-0 January 2014

F-1001MRH-C

L-0 June 2001
M-0 March 2002
N-0 December 2002
N-1 May 2003
P-0 December 2003
Q-0 January 2005
R-0 May 2006
S-0 January 2007
T-0 April 2008
T-1 August 2008
U-0 January 2009
V-0 January 2010
V-1 June 2010
V-2 October 2010
V-3 November 2010
A-0 January 2011
B-0 January 2012
B-1 March 2012
C-0 January 2013
C-1 June 2013
C-2 September 2013
D-0 January 2014

F-1001MLH

L-0 July 2001
M-0 February 2002
N-0 December 2002
N-1 May 2003
P-0 January 2004
Q-0 March 2005
R-0 January 2006
S-0 January 2007
T-0 January 2008
T-1 October 2008
U-0 February 2009
V-0 February 2010
V-1 May 2010
V-3 November 2010
A-0 January 2011
B-0 January 2012
B-1 March 2012
C-0 February 2013
C-1 September 2013
D-0 January 2014

F-1001MLH-C

M-0 February 2002

Auxiliary Code Breakdown

The auxiliary code is the first two characters in the serial number. The first character indicates the year. Years progress or regress in alphabetical order. The series runs from "A" through "V" and the letters "I" and "O" are skipped. The second character indicates significant part changes within a year. Base is "0" and this number advances for each change. In cases where there is a letter in parentheses, this designates the month. This is the last character in the serial number. The series runs from "(A)" through "(M)" and the letter "(I)" is skipped. This designation is only included when identifying a parts change within an auxiliary code.

Note About Ordering Parts

Most assemblies cannot be ordered as complete units; parts in the assemblies generally must be ordered separately.

A. Main Assembly & Refrigeration Circuit
F-1001MAH(-C)
 L-0 to D-0

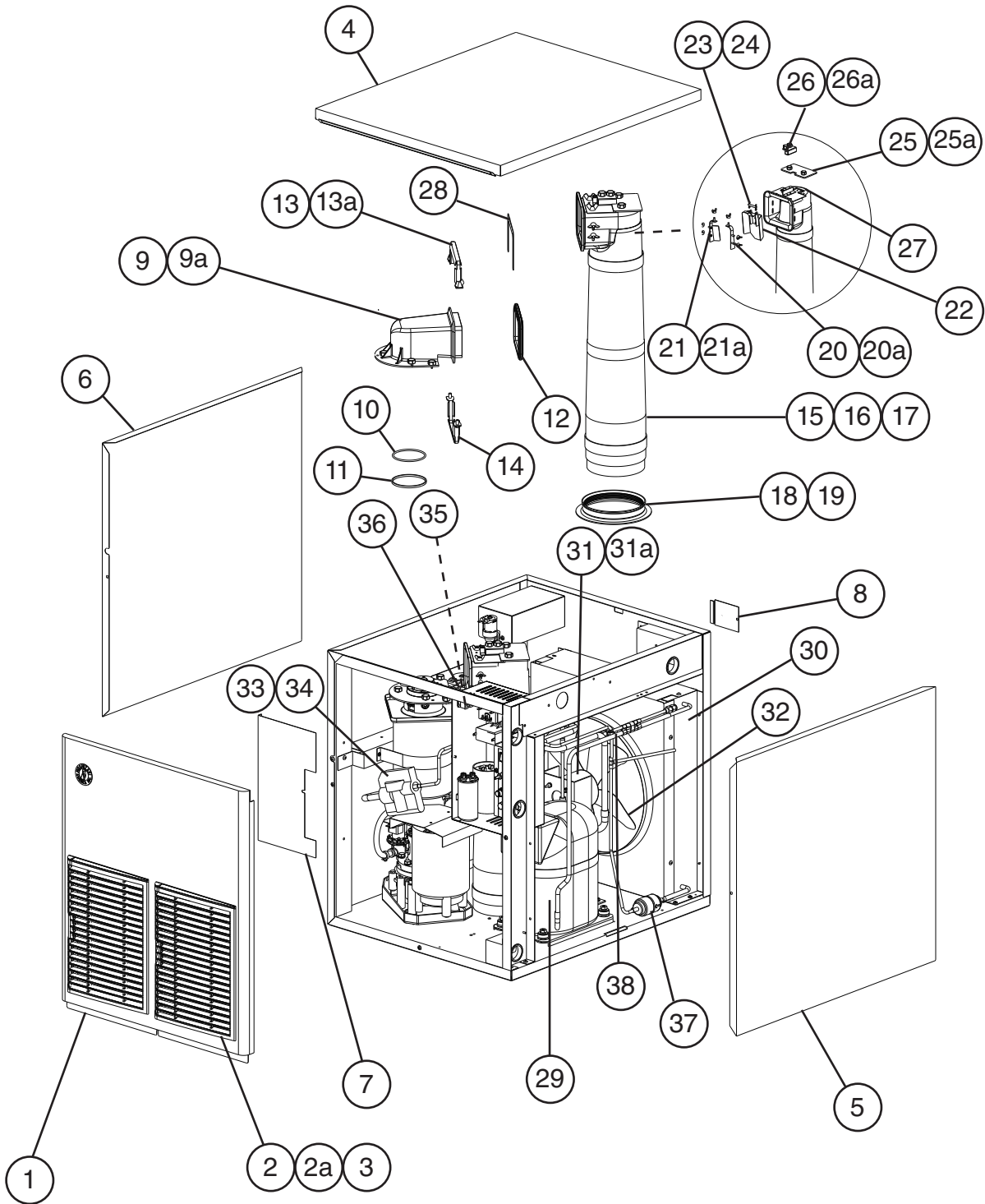

Title: A. Main Assembly & Refrigeration Circuit Model: F-1001MAH(-C)												
Index No.	Description	Material or Model Number	Part Number	Required Number								
				L-0 to T-0	T-1 to C-1	C-2 D-0						
Main Assembly												
1	Front Panel		2A2071-01	1	1	1						
2	Louver		1A0548-01	2	2	2						
2a	Push Retainer		4A2414-01	6	6	6						
3	Air Filter		2A2063G01	2	2	2						
4	Top Panel		2A2064-01	1	1	1						
5	Right Side Panel		2A2073G01	1	1	1						
6	Left Side Panel		2A2072G01	1	1	1						
7	Control Box Cover		3A1721-01	1	1	1						
8	Junction Box Cover		433410-01	1	1	1						
9	Spout		104797-01	1	1	1						
9a	Thumbscrew		415949G08	5	5	5						
10	O-Ring		4A4755-03	1	1	1						
11	Nylon Ring		432661-02	1	1	1						
12	Spout-to-Chute Packing		321037-01	1	1	1						
13	Upper Strap		328703-02	1	1	1						
13a	Wing Nut		7E12-0600	2	2	2						
14	Lower Strap		321038G02	1	1	1						
15	Chute		2A1919-01	1	1	1						
16	Chute Insulation		2A1920-01	1	1	1						
17	Chute Tie		436531G01	1	1	1						
18	Chute Packing		432877-01	1	1	1						
19	Ring		3A1017-01	1	1	1						
20	Chute Baffle A		3A0400G01	1	1	1						
20a	Wing Nut		7E12-0400	3	3	3						
21	Chute Baffle B		3A0399G01	1	1	1						
21a	Wing Nut	4, SS	7E12-0400	3	3	3						
22	Actuator		436848G01	1	1	1						
23	Shaft		436851-01	1	1	1						
24	Snap Pin		715S-0005	2	2	2						
25	Plate		4A2039-01	1	1	1						
25a	Thumbscrew		415949G10	2	2	2						
26	Bin Control (proximity switch)		4A2033-01	1	1	1						
26a	Thumbscrew		415949G08	2	2	2						
27	Bin Control Bracket (proximity switch)		3A1744G01	1	1	1						
28	Spout-to-Chute Bracket		4A1712-01	1	1	1						

Title: A. Main Assembly & Refrigeration Circuit Model: F-1001MAH(-C)												
Index No.	Description	Material or Model Number	Part Number	Required Number								
				L-0 to T-0	T-1 to C-1	C-2 D-0						
Refrigeration Circuit												
29	Compressor		4A1322-01	1	1	-						
			3A6900-01			1						
30	Condenser		211663-02	1	1	1						
31	Fan Motor		440911-01	1	-							
			4A3158-01		1	1						
31a	Self-Locking Nut	8-32	7N2110832	4	4	4						
32	Fan Blade		4A0197-01	1	1	1						
33	Thermostatic Expansion Valve		4A1117-01	1	1	1						
34	Thermostatic Expansion Valve Cover		4A1168-01	1	1	1						
35	Thermostatic Expansion Valve Bulb Holder		3A0112-01	1	1	1						
36	High-Pressure Switch		433441-05	1	1	-						
			463180-04			1						
37	Drier		4A1113-01	1	1	1						
38	Heat Exchanger		3A1662G01	1	1	-						
			3A7886G01			1						

A. Main Assembly & Refrigeration Circuit
F-1001MWH(-C)
 L-0 to D-0

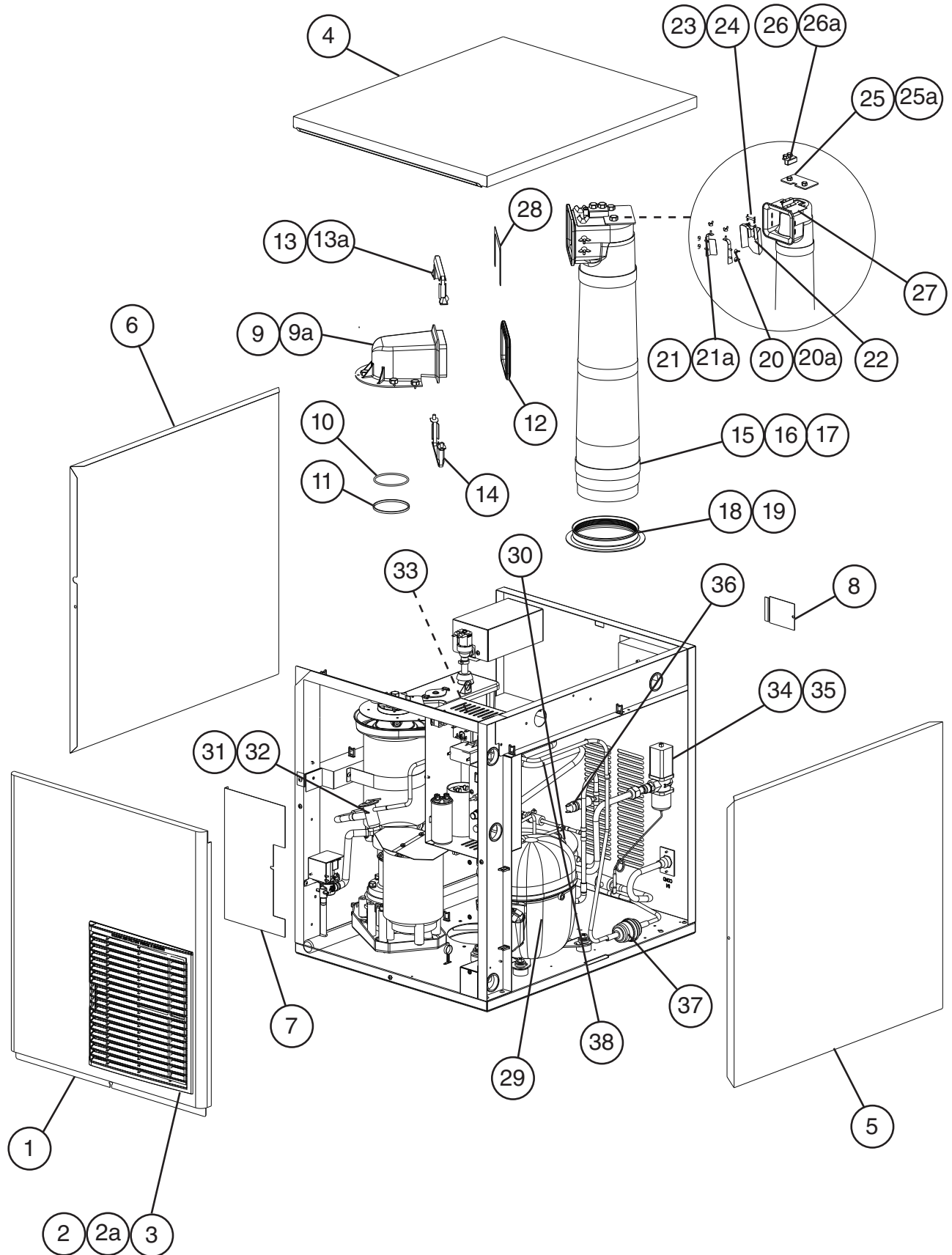

Title: A. Main Assembly & Refrigeration Circuit Model: F-1001MWH(-C)											
Index No.	Description	Material or Model Number	Part Number	Required Number							
				L-0 to T-0	T-1 to B-1	C-0 C-1	C-2 D-0				
Main Assembly											
1	Front Panel		2A2124-01	1	1	1	1				
2	Louver		1A0547-01	1	1	1	1				
2a	Push Retainer		4A2414-01	3	3	3	3				
3	Air Filter		2A2062G01	1	1	1	1				
4	Top Panel		2A2064-01	1	1	1	1				
5	Right Side Panel		2A2073G01	1	1	1	1				
6	Left Side Panel		2A2072G01	1	1	1	1				
7	Control Box Cover		3A1721-01	1	1	1	1				
8	Junction Box Cover		433410-01	1	1	1	1				
9	Spout		104797-01	1	1	1	1				
9a	Thumbscrew		415949G08	5	5	5	5				
10	O-Ring		4A4755-03	1	1	1	1				
11	Nylon Ring		432661-02	1	1	1	1				
12	Spout-to-Chute Packing		321037-01	1	1	1	1				
13	Upper Strap		328703-02	1	1	1	1				
13a	Wing Nut		7E12-0600	2	2	2	2				
14	Lower Strap		321038G02	1	1	1	1				
15	Chute		2A1919-01	1	1	1	1				
16	Chute Insulation		2A1920-01	1	1	1	1				
17	Chute Tie		436531G01	1	1	1	1				
18	Chute Packing		432877-01	1	1	1	1				
19	Ring		3A1017-01	1	1	1	1				
20	Chute Baffle A		3A0400G01	1	1	1	1				
20a	Wing Nut	4, SS	7E12-0400	3	3	3	3				
21	Chute Baffle B		3A0399G01	1	1	1	1				
21a	Wing Nut	4, SS	7E12-0400	3	3	3	3				
22	Actuator		436848G01	1	1	1	1				
23	Shaft		436851-01	1	1	1	1				
24	Snap Pin		715S-0005	2	2	2	2				
25	Plate		4A2039-01	1	1	1	1				
25a	Thumbscrew		415949G10	2	2	2	2				
26	Bin Control (proximity switch)		4A2033-01	1	1	1	1				
26a	Thumbscrew		415949G08	2	2	2	2				
27	Bin Control Bracket (proximity switch)		3A1744G01	1	1	1	1				
28	Spout-to-Chute Bracket		4A1712-01	1	1	1	1				

Title: A. Main Assembly & Refrigeration Circuit Model: F-1001MWH(-C)													
Index No.	Description	Material or Model Number	Part Number	Required Number									
				L-0 to T-0	T-1 to B-1	C-0 to C-1	C-2 to D-0						
Refrigeration Circuit													
29	Compressor		4A1322-01	1	1	1	-						
			3A6900-01				1						
30	Condenser	S-0725	215545G01	1	-								
		HS-0162	2A2359G03		1	-							
			3A7323-01			1	-						
			3A7321-01				1						
31	Thermostatic Expansion Valve		4A1117-01	1	1	1	1						
32	Thermostatic Expansion Valve Cover		4A1168-01	1	1	1	1						
33	Thermostatic Expansion Valve Bulb Holder		3A0112-01	1	1	1	1						
34	Water Regulating Valve		4A0911-04	1	1	1	1						
35	Male Connector		4A1087-01	1	1	1	1						
36	High-Pressure Switch		433441-05	1	1	1	-						
			463180-05				1						
37	Drier		4A1113-01	1	1	1	1						
38	Heat Exchanger		3A1662G01	1	1	1	-						
			3A7886G01				1						

A. Main Assembly and Refrigeration Circuit
F-1001MRH(-C)
 L-0 to D-0

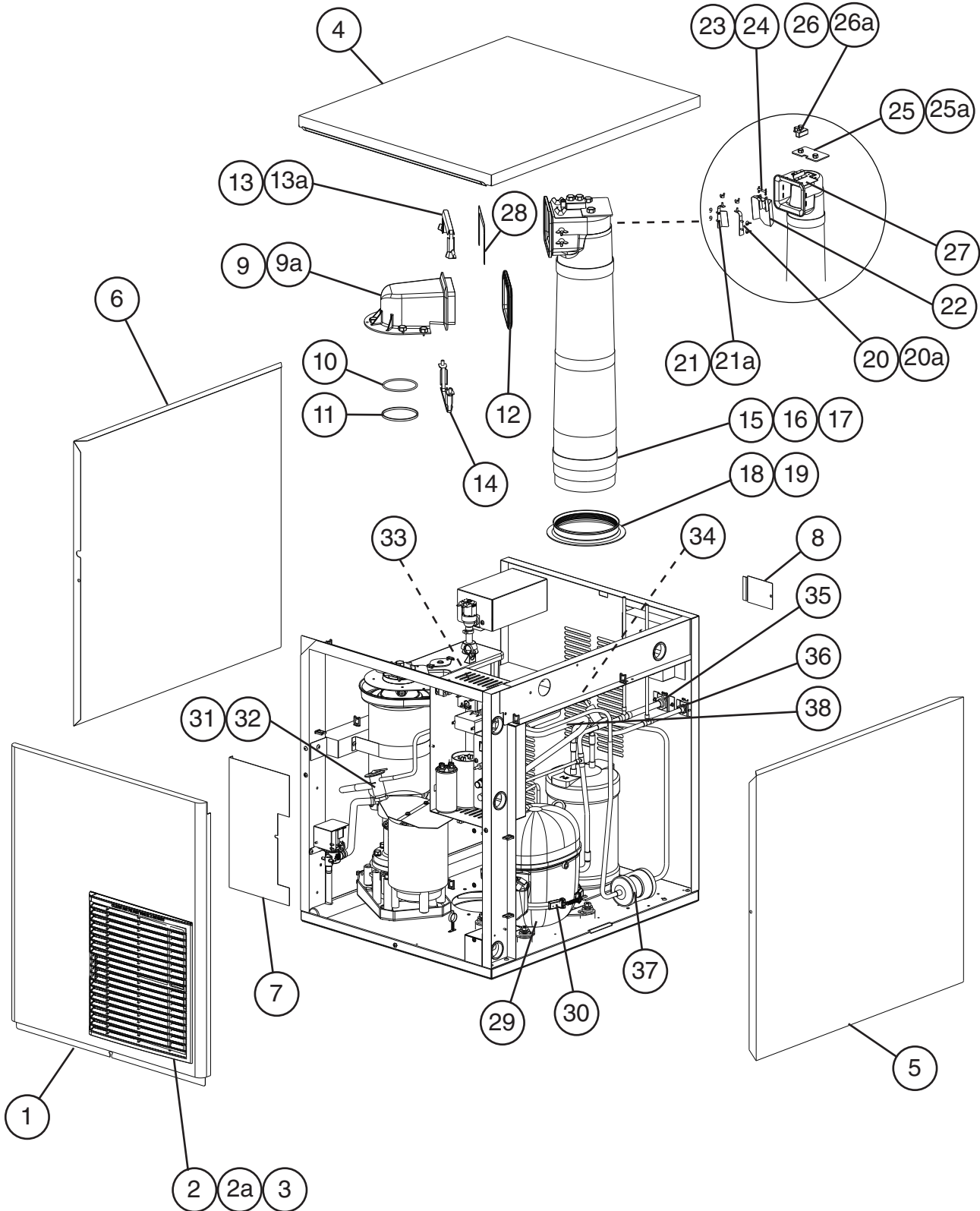

Title: A. Main Assembly & Refrigeration Circuit Model: F-1001MRH(-C)											
Index No.	Description	Material or Model Number	Part Number	Required Number							
				L-0 to C-1	C-2 D-0						
Main Assembly											
1	Front Panel		2A2124-01	1	1						
2	Louver		1A0547-01	1	1						
2a	Push Retainer		4A2414-01	3	3						
3	Air Filter		2A2062G01	1	1						
4	Top Panel		2A2064-01	1	1						
5	Right Side Panel		2A2073G01	1	1						
6	Left Side Panel		2A2072G01	1	1						
7	Control Box Cover		3A1721-01	1	1						
8	Junction Box Cover		433410-01	2	2						
9	Spout		104797-01	1	1						
9a	Thumbscrew		415949G08	5	5						
10	O-Ring		4A4755-03	1	1						
11	Nylon Ring		432661-02	1	1						
12	Spout-to-Chute Packing		321037-01	1	1						
13	Upper Strap		328703-02	1	1						
13a	Wing Nut		7E12-0600	2	2						
14	Lower Strap		321038G02	1	1						
15	Chute		2A1919-01	1	1						
16	Chute Insulation		2A1920-01	1	1						
17	Chute Tie		436531G01	1	1						
18	Chute Packing		432877-01	1	1						
19	Ring		3A1017-01	1	1						
20	Chute Baffle A		3A0400G01	1	1						
20a	Wing Nut	4, SS	7E12-0400	3	3						
21	Chute Baffle B		3A0399G01	1	1						
21a	Wing Nut	4, SS	7E12-0400	3	3						
22	Actuator		436848G01	1	1						
23	Shaft		436851-01	1	1						
24	Snap Pin		715S-0005	2	2						
25	Plate		4A2039-01	1	1						
25a	Thumbscrew		415949G10	2	2						
26	Bin Control (proximity switch)		4A2033-01	1	1						
26a	Thumbscrew		415949G08	2	2						
27	Bin Control Bracket (proximity switch)		3A1744G01	1	1						
28	Spout-to-Chute Bracket		4A1712-01	1	1						

Title: A. Main Assembly & Refrigeration Circuit Model: F-1001MRH(-C)												
Index No.	Description	Material or Model Number	Part Number	Required Number								
				L-0 to C-1	C-2 D-0							
Refrigeration Circuit												
29	Compressor		4A1322-01	1	-							
			3A6900-01		1							
30	Crankcase Heater		434186-01	1	-							
			4A5091-01		1							
31	Thermostatic Expansion Valve		4A1117-01	1	1							
32	Thermostatic Expansion Valve Cover		4A1168-01	1	1							
33	Thermostatic Expansion Valve Bulb Holder		3A0112-01	1	1							
34	High-Pressure Switch		433441-05	1	-							
			463180-04		1							
35	Discharge Line Coupling		434132G01	1	1							
36	Liquid Line Coupling		433751G01	1	1							
37	Drier		4A1338-01	1	1							
38	Heat Exchanger		3A1736G01	1	-							
			3A7886G01		1							

A. Main Assembly and Refrigeration Circuit
F-1001MLH(-C)
 L-0 to D-0

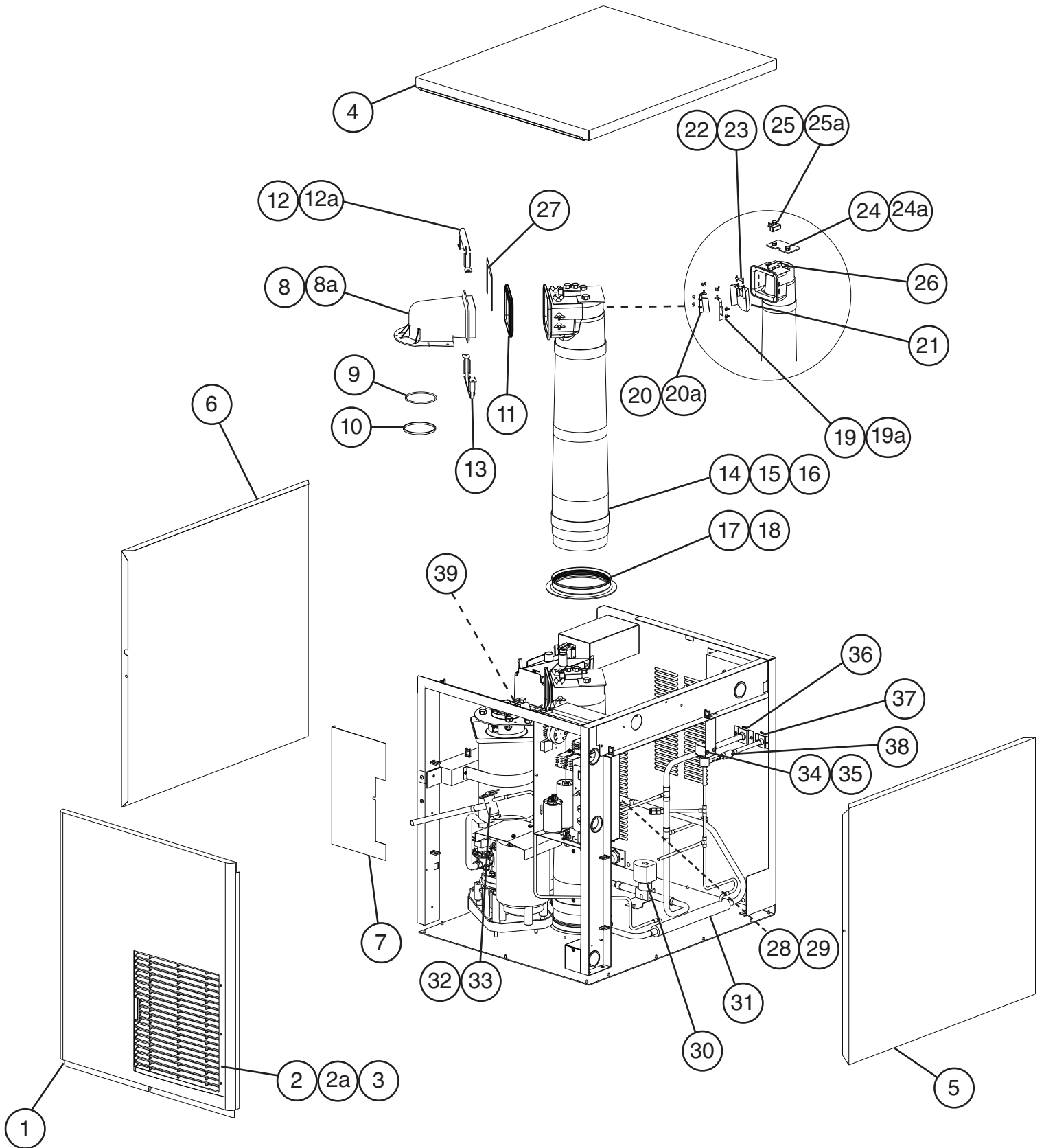

Title: A. Main Assembly & Refrigeration Circuit Model: F-1001MLH(-C)												
Index No.	Description	Material or Model Number	Part Number	Required Number								
				L-0 to T-0	T-1 to D-0							
Main Assembly												
1	Front Panel		2A2124-01	1	1							
2	Louver		1A0547-01	1	1							
2a	Push Retainer		4A2414-01	3	3							
3	Air Filter		2A2062G01	1	1							
4	Top Panel		2A2064-01	1	1							
5	Right Side Panel		2A2073G01	1	1							
6	Left Side Panel		2A2072G01	1	1							
7	Control Box Cover		3A0411-01	1	1							
8	Spout		104797-01	1	1							
8a	Thumbscrew		415949G08	5	5							
9	O-Ring		4A4755-03	1	1							
10	Nylon Ring		432661-02	1	1							
11	Spout-to-Chute Packing		321037-01	1	1							
12	Upper Strap		328703-02	1	1							
12a	Wing Nut		7E12-0600	2	2							
13	Lower Strap		321038G02	1	1							
14	Chute		2A1919-01	1	1							
15	Chute Insulation		2A1920-01	1	1							
16	Chute Tie		436531G01	1	1							
17	Chute Packing		432877-01	1	1							
18	Ring		3A1017-01	1	1							
19	Chute Baffle A		3A0400G01	1	1							
19a	Wing Nut	4, SS	7E12-0400	3	3							
20	Chute Baffle B		3A0399G01	1	1							
20a	Wing Nut	4, SS	7E12-0400	3	3							
21	Actuator		436848G01	1	1							
22	Shaft		436851-01	1	1							
23	Snap Pin		715S-0005	2	2							
24	Plate		4A2039-01	1	1							
24a	Thumbscrew		415949G10	2	2							
25	Bin Control (proximity switch)		4A2033-01	1	1							
25a	Thumbscrew		415949G08	2	2							
26	Bin Control Bracket (proximity switch)		3A1744G01	1	1							
27	Spout-to-Chute Bracket		4A1712-01	1	1							

Title: A. Main Assembly & Refrigeration Circuit Model: F-1001MLH(-C)												
Index No.	Description	Material or Model Number	Part Number	Required Number								
				L-0 to T-0	T-1 to D-0							
Refrigeration Circuit												
28	Evaporator Pressure Regulator (EPR) Valve		4A1384-01	1	1							
29	Evaporator Pressure Regulator (EPR) Valve Cover		340434-01	1	1							
30	Suction Line Valve		446873-01	1	1							
31	Heat Exchanger		4A1374-01	1	1							
32	Thermostatic Expansion Valve		4A1117-01	1	1							
33	Thermostatic Expansion Valve Cover		4A1168-01	1	1							
34	Liquid Line Valve Body		440352-01	1	-							
			4A3276-01		1							
35	Valve Coil		440353-01	1	-							
			4A3277-01		1							
36	Discharge Line Coupling		434132G01	1	1							
37	Liquid Line Coupling		433751G01	1	1							
38	Strainer		4A1385-01	1	1							
39	Thermostatic Expansion Valve Bulb Holder		438246-01	1	1							

B. Icemaking Unit
F-1001M_H(-C)
 L-0 to D-0

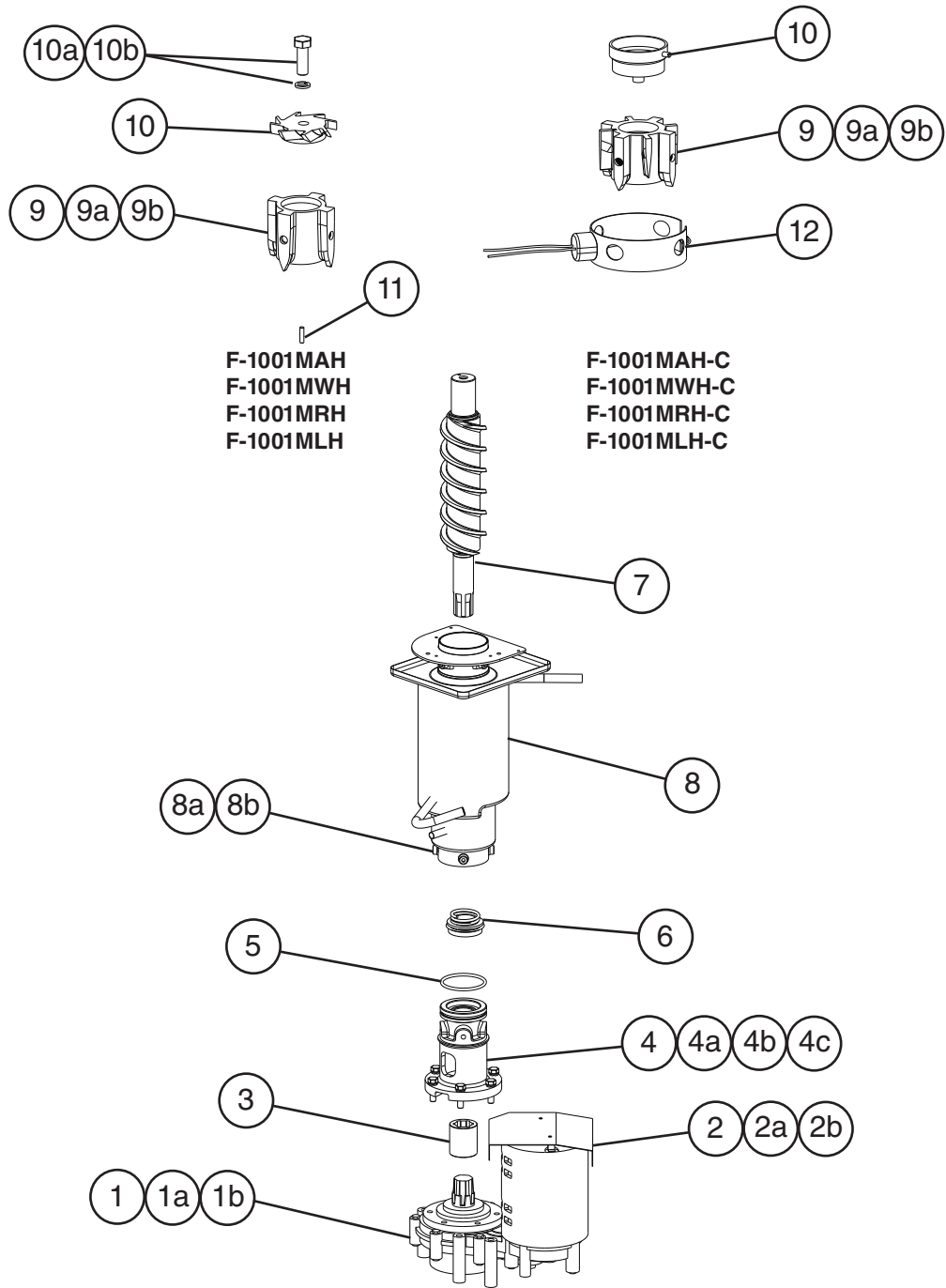

Title: B. Icemaking Unit Model: F-1001M_H(-C)											
Index No.	Description	Material or Model Number	Part Number	Required Number							
				L-0 to U-0 (H)	U-0 (J) to C-1	C-2 D-0					
1	Gear Motor		4A2007-01	1	1	1					
1a	Socket Head Cap Screw		7S12-0811	3	3	3					
1b	Split Lock Washer		7L22-0800	3	3	3					
2	Gear Motor Barrier		3A1732-01	1	1	1					
2a	Truss Head Screw	4x8, SS	7C32-0408	2	2	2					
2b	Rubber Washer		4A5268-01	2	2	2					
3	Spline Coupling		414137-01	1	1	1					
4	Housing		2A1977G01	1	1	1					
4a	Hex Head Bolt	8x30, SS	7B02-0830	6	6	6					
4b	Plain Washer	8, SS	7W22-0800	6	6	6					
4c	Split Lock Washer	8, SS	7L22-0800	6	6	6					
5	O-Ring		7616-G065	1	-						
			4A4755-02		1	1					
6	Mechanical Seal		432492-01	1	1	1					
7	Auger		120863G02	1	1	1					
8	Evaporator		2A3312G01	1	1	1					
8a	Socket Head Cap Screw	8x12, SS	7S12-0812	4	4	4					
8b	Split Lock Washer	8, SS	7L22-0800	4	4	4					
9	Extruding Head	F-1001M_H	3A2175G01	1	1	1					
		F-1001M_H-C	3A2176G01	1	1	1					
9a	Seal Bolt		P01768-01	4	4	4					
9b	Washer		427184-01	4	4	4					
10	Cutter	F-1001M_H	3A1395-02	1	1	1					
		F-1001M_H-C	327145-01	1	1	-					
			427183G01			1					
10a	Hex Head Bolt	F-1001M_H	7B02-1030	1	1	1					
10b	Split Lock Washer	F-1001M_H	7L22-1000	1	1	1					
11	Dowel Pin	F-1001M_H	713S-0416	1	1	1					
12	Heater	F-1001M_H-C	4A2292-01	1	1	1					

C. Water Circuit
F-1001M_H(-C)
L-0 to D-0

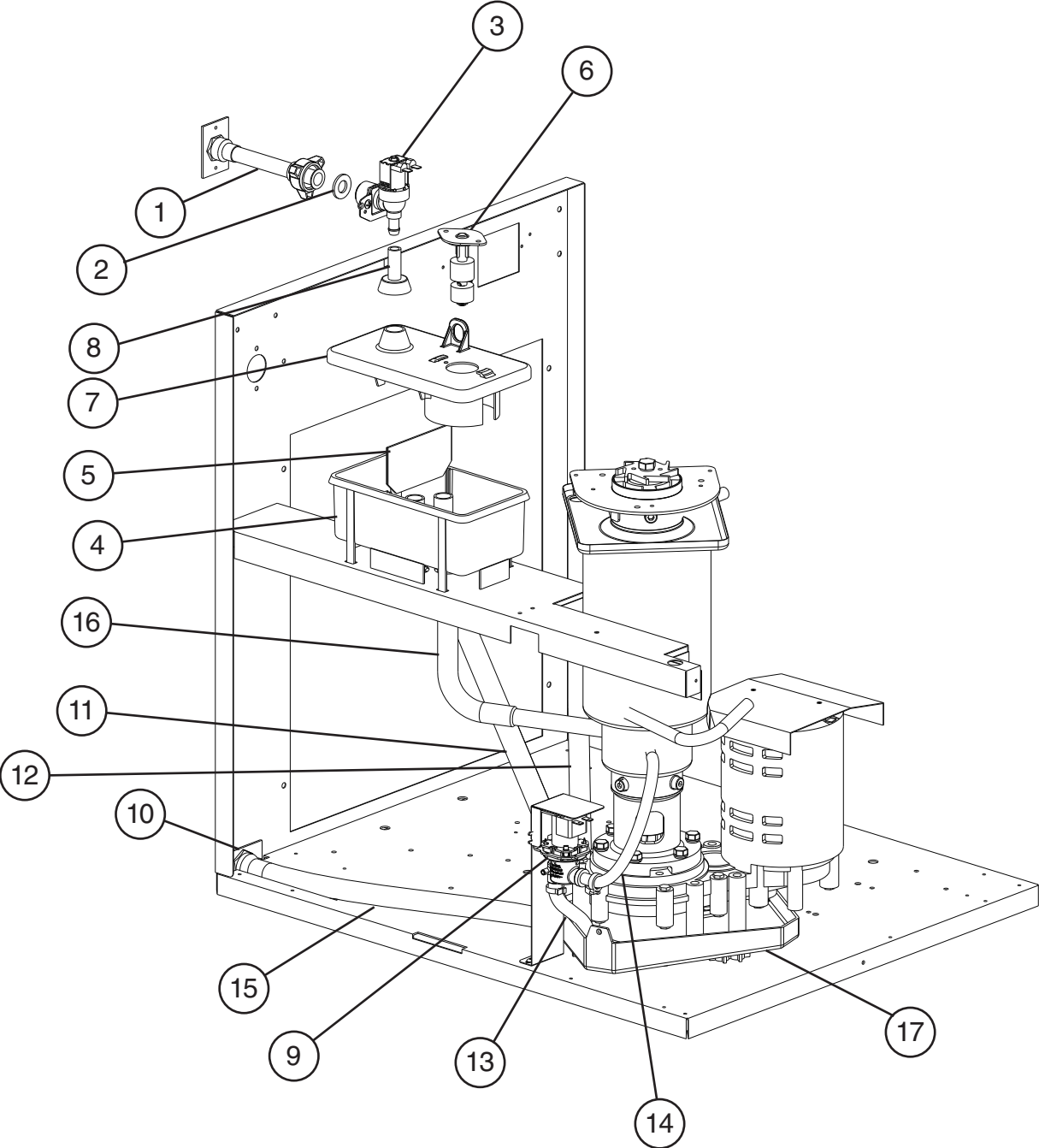

Title: C. Water Circuit Model: F-1001M_H(-C)												
Index No.	Description	Material or Model Number	Part Number	Required Number								
				L-0 to B-0	B-1 to D-0							
1	Water Supply Pipe		4A0891G01	1	-							
			4A0891G02		1							
2	Washer		4A0867-01	1	1							
3	Inlet Water Valve		4A0865-01	1	-							
			4A5309-01		1							
4	Reservoir		2A0753-01	1	1							
5	Reservoir Separator		4A1255-01	1	1							
6	Float Switch		435490-01	1	1							
7	Reservoir Cover		214810-01	1	1							
8	Reservoir Inlet		4A0869-01	1	1							
9	Drain Valve		4A2772-01	1	1							
10	Drain Fitting		4A0776G01	1	1							
11	Silicone Hose	L=440 mm	7730-1822	1	1							
12	Silicone Hose	L=225 mm	7730I3896	1	1							
13	Vinyl Hose	L=67 mm	7716-0913	1	1							
14	Vinyl Hose	L=460 mm	7725-1923	1	1							
15	Vinyl Hose	L=400 mm	7716-2025	1	1							
16	Reservoir Hose		4A1165-06	1	1							
17	Drain Pan		323765G02	1	1							
Clamps												
	Hose Clamp	21-26 mm	4A2017-01	1	1							
	Hose Clamp	26-30 mm	4A2017-02	1	1							
	Hose Clamp	17-21 mm	4A2017-05	1	1							
	Hose Clamp	19-22 mm	4A2017-06	1	1							
	Hose Clamp	13-15 mm	4A2017-08	4	4							

D. Control Box Assembly
F-1001M_H(-C)
L-0 to D-0

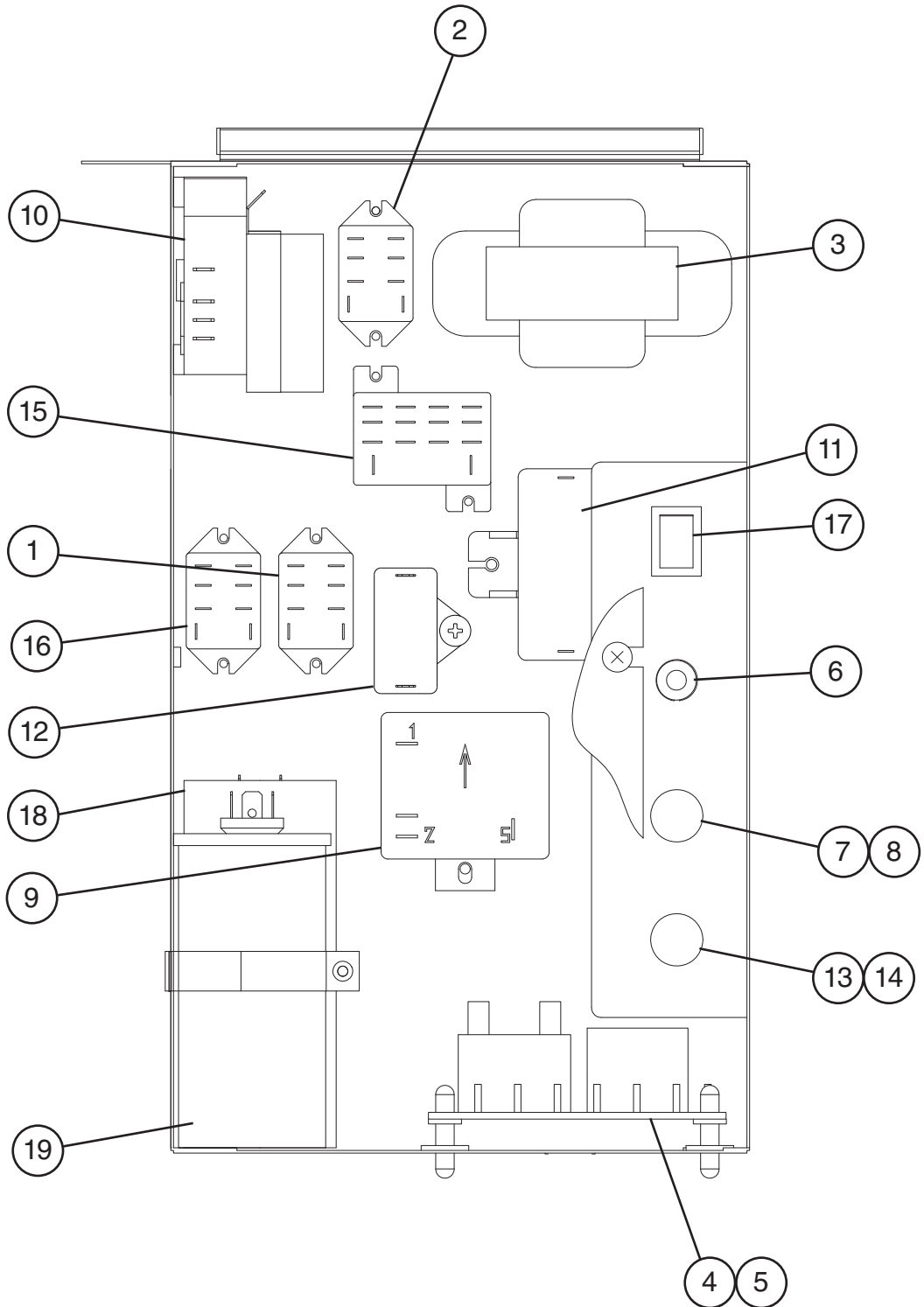

Title: D. Control Box Assembly		Model: F-1001M_H(-C)		Required Number								
Index No.	Description	Material or Model Number	Part Number	L-0 to L-0 (J)	L-0 (K) to C-0	C-1 to C-2	C-2 TO D-0	D-0				
				1	Compressor Control Relay/Gear Motor Protect Relay	F-1001MAH(-C) F-1001MWH(-C) F-1001MRH(-C) F-1001MLH(-C)	418271-03 406132-07	1 1	1 1	1 1	1 1	1 1
2	Water Control Relay		406132-03	1	1	1	1	1				
3	Control Transformer		4A0557-01	1	1	1	1	1				
4	Control Board		437305-01	1	1	-						
	"F-B" Control Board		4A5591-01 2A8053-01			1	1	-		1		
5	Control Board Support		4A0336-03	4	4	4	4	4				
6	Power Switch (toggle switch)		4A2332-01	1	1	1	1	1				
7	Fuse Holder		4A3449-01	1	1	1	1	1				
8	Control Board Fuse	AGC-1A, 250VAC	4A0893-01	1	1	1	1	1				
9	Start Relay	F-1001MAH(-C) F-1001MWH(-C) F-1001MRH(-C)	4A1107-13	1	1	1	-					
			4A1107-07					1				
			4A1107-01						1			
10	Drain Timer		4A2157-01	1	1	-						
11	Gear Motor Capacitor	24MFD, 250VAC	4A2273-01	1	1	1	1	1				
12	Fan Motor Capacitor	F-1001MAH(-C) 5MFD, 250VAC	443192-02	1	1	1	1	1				
13	Gear Motor Fuse	GMD-3A, 250VAC Slow Blow	4A0893-06	1	1	1	1	1				
14	Fuse Holder		4A3449-02	1	1	1	1	1				
15	Gear Motor Relay	F-1001MAH(-C) F-1001MWH(-C) F-1001MRH(-C)	406133-04	1	1	1	1	1				
16	Circuit Protect Relay		418271-05	1	1	1	1	1				
17	Control Switch (rocker switch)		4A0558-01	1	1	1	1	1				
18	Start Capacitor	F-1001MAH(-C) F-1001MWH(-C) F-1001MRH(-C) 108-130MFD, 250VAC	3A0076-02	1	1	1	-					
			3A0076-22					1	1			
19	Run Capacitor	F-1001MAH(-C) F-1001MWH(-C) F-1001MRH(-C) 25MFD, 370VAC	439943-02	1	-							
			3A2005-06		1	1	-					
			3A2005-10					1	1			

E. Accessories & Labels

F-1001M_H(-C)

L-0 to D-0

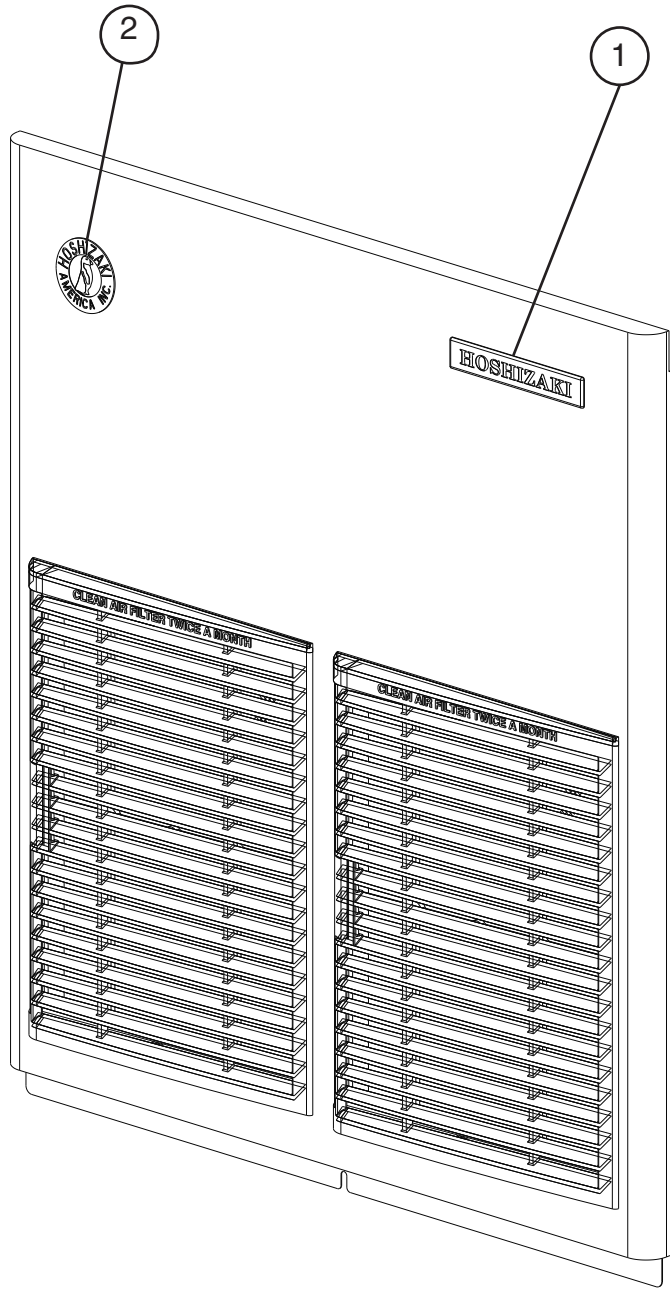

Title: E. Accessories & Labels Model: F-1001M_H(-C)													
Index No.	Description	Material or Model Number	Part Number	Required Number									
				L-0 to D-0									
1	Hoshizaki Emblem Label		4A0560-01	1									
2	Penguin Label		4A0526-01	1									
3	Universal Brace		4A0363-01	2									
3a	Hex Bolt		7B02-0512	2									