

NO. U2AF - 182

ISSUED: APR. 20, 1990

REVISED: _____

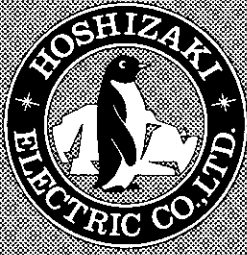

SERVICE MANUAL

MODULAR FLAKER

F - 1100MAA

F - 1100MWA

F - 1100MRA

FOREWORD

This Service Manual contains the specifications and information in regard to transporting, unpacking, installing, operating and servicing the machine. You are encouraged to read it thoroughly in order to obtain maximum performance. You will find details on the construction, installation and maintenance.

If you encounter any problem not covered in this Service Manual, feel free to contact Hoshizaki America, Inc. We will be happy to provide whatever assistance is necessary.

Keep this Service Manual handy, and read it again when questions arise.

HOSHIZAKI AMERICA, INC.

**618 HIGHWAY 74 SOUTH, PEACHTREE CITY,
GEORGIA 30269 U.S.A.
PHONE: 404-487-2331**

CONTENTS

PAGE

I. SPECIFICATIONS	1
1. NAMEPLATE RATING	1
[a] F-1100MAA (Air-cooled)	1
[b] F-1100MWA (Water-cooled)	2
[c] F-1100MRA (Remote Air-cooled)	3
2. DIMENSIONS/CONNECTIONS	4
[a] F-1100MAA	4
[b] F-1100MWA	5
[c] F-1100MRA	6
[d] WITH ICE STORAGE BIN	7
3. SPECIFICATIONS	8
[a] F-1100MAA	8
[b] F-1100MWA	9
[c] F-1100MRA	10
4. CONDENSER UNIT MODEL URC-6A	11
II. GENERAL INFORMATION	12
1. CONSTRUCTION	12
[a] F-1100MAA	12
[b] F-1100MWA	13
[c] F-1100MRA	14
2. CONTROL BOX LAYOUT	15
III. INSTALLATION AND OPERATING INSTRUCTIONS	16
1. CHECKS BEFORE INSTALLATION	16
2. HOW TO REMOVE PANELS	16
3. LOCATION	17
4. SET UP	17
5. INSTALLATION OF BIN CONTROL	19
6. ELECTRICAL CONNECTION	20
7. INSTALLATION AND OPERATING INSTRUCTIONS	21
[a] CHECKS BEFORE INSTALLATION	21
[b] LOCATION	21
[c] SET UP	22
[d] ELECTRICAL CONNECTION	23
[e] STACKING CONDENSER UNIT	24
8. WATER SUPPLY AND DRAIN CONNECTIONS	25
9. FINAL CHECK LIST	27
10. START UP	28
11. PREPARING THE ICEMAKER FOR LONG STORAGE	29



IV. MAINTENANCE AND CLEANING INSTRUCTIONS	31
1. CLEANING INSTRUCTIONS	31
2. MAINTENANCE	35
V. TECHNICAL INFORMATION	36
1. WATER CIRCUIT AND REFRIGERANT CIRCUIT	36
[a] F-1100MAA (Air-cooled)	36
[b] F-1100MWA (Water-cooled)	37
[c] F-1100MRA (Remote Air-cooled)	38
2. WIRING DIAGRAM	39
[a] F-1100MAA	39
[b] F-1100MWA	40
[c] F-1100MRA	41
[d] SEQUENCE OF ELECTRICAL CIRCUITS	42
3. TIMING CHART	49
4. PERFORMANCE DATA	51
[a] F-1100MAA	51
[b] F-1100MWA	54
[c] F-1100MRA	57
VI. SERVICE DIAGNOSIS	60
1. NO ICE PRODUCTION	60
2. LOW ICE PRODUCTION	62
3. OTHERS	62
VII. REMOVAL AND REPLACEMENT OF COMPONENTS	64
1. SERVICE FOR REFRIGERANT LINES	64
[a] REFRIGERANT DISCHARGE	64
[b] EVACUATION AND RECHARGE	64
2. BRAZING	65
3. REMOVAL AND REPLACEMENT OF COMPRESSOR	65
4. REMOVAL AND REPLACEMENT OF DRIER	67
5. REMOVAL AND REPLACEMENT OF EXPANSION VALVE	68
6. REMOVAL AND REPLACEMENT OF WATER REGULATING VALVE	
- WATER-COOLED MODEL ONLY	69
7. REMOVAL AND REPLACEMENT OF CONDENSING PRESSURE REGULATOR	
- REMOTE AIR-COOLED MODEL ONLY	70
8. REMOVAL AND REPLACEMENT OF COMPONENTS OF EVAPORATOR	
ASSEMBLY	71
9. REMOVAL AND REPLACEMENT OF FAN MOTOR	75
10. REMOVAL AND REPLACEMENT OF WATER VALVE	75
VIII. ADJUSTMENT OF COMPONENTS	76
1. ADJUSTMENT OF WATER REGULATING VALVE	76
2. ADJUSTMENT OF CUTTER	77

I. SPECIFICATIONS

1. NAMEPLATE RATING

[a] F-1100MAA (Air-cooled)

HOSHIZAKI ICE MAKER	
MODEL NUMBER	F-1100MAA
AC SUPPLY VOLTAGE	230-240/60/1(3wire with Neutral for 115V)
AMPERES	6.4AMPS
MAXIMUM FUSE SIZE	15AMPS
MINIMUM CIRCUIT AMPACITY	15AMPS
DESIGN PRESSURE	HI-400PSI LO-230PSI
REFRIGERANT 502	1lb. 8oz.
MOTOR-COMPRESSOR THERMALLY PROTECTED	
SERIAL NUMBER	

 HOSHIZAKI ELECTRIC CO., LTD. AICHI JAPAN	
 LISTED ICE MAKER WITHOUT STORAGE MEANS 946Z	 NATIONAL SANITATION FOUNDATION

See NAMEPLATE for electrical and refrigeration specifications. This nameplate is located on the upper right hand side of rear panel.

We reserve the right to make changes in specifications and design without prior notice.

[b] F-1100MWA (Water-cooled)

HOSHIZAKI ICE MAKER	
MODEL NUMBER	F-1100MWA
AC SUPPLY VOLTAGE	230-240/60/1
AMPERES	5.5AMPS
MAXIMUM FUSE SIZE	15AMPS
MINIMUM CIRCUIT AMPACITY	15AMPS
DESIGN PRESSURE	HI-400PSI LO-230PSI
REFRIGERANT 502	1lb. 1oz.
MOTOR-COMPRESSOR THERMALLY PROTECTED	
SERIAL NUMBER	

 **HOSHIZAKI ELECTRIC CO., LTD.**
AICHI JAPAN

 LISTED
ICE MAKER
WITHOUT
STORAGE MEANS
946Z

 NATIONAL SANITATION FOUNDATION

See NAMEPLATE for electrical and refrigeration specifications. This nameplate is located on the upper right hand side of rear panel.

We reserve the right to make changes in specifications and design without prior notice.

[c] F-1100MRA (Remote Air-cooled)

HOSHIZAKI ICE MAKER

MODEL NUMBER	F-1100MRA
AC SUPPLY VOLTAGE	230-240/60/1(3 wire with Neutral for 115V)
AMPERES	6.4AMPS
MAXIMUM FUSE SIZE	15AMPS
MINIMUM CIRCUIT AMPACITY	15AMPS
DESIGN PRESSURE	HI-400PSI LO-230PSI
REFRIGERANT 502	
MOTOR-COMPRESSOR THERMALLY PROTECTED	
SERIAL NUMBER	

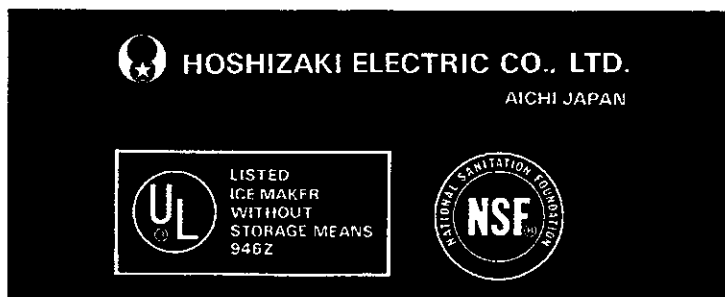

See NAMEPLATE for electrical and refrigeration specifications. This nameplate is located on the upper right hand side of rear panel.

We reserve the right to make changes in specifications and design without prior notice.

2. DIMENSIONS/CONNECTIONS

[a] F-1100MAA

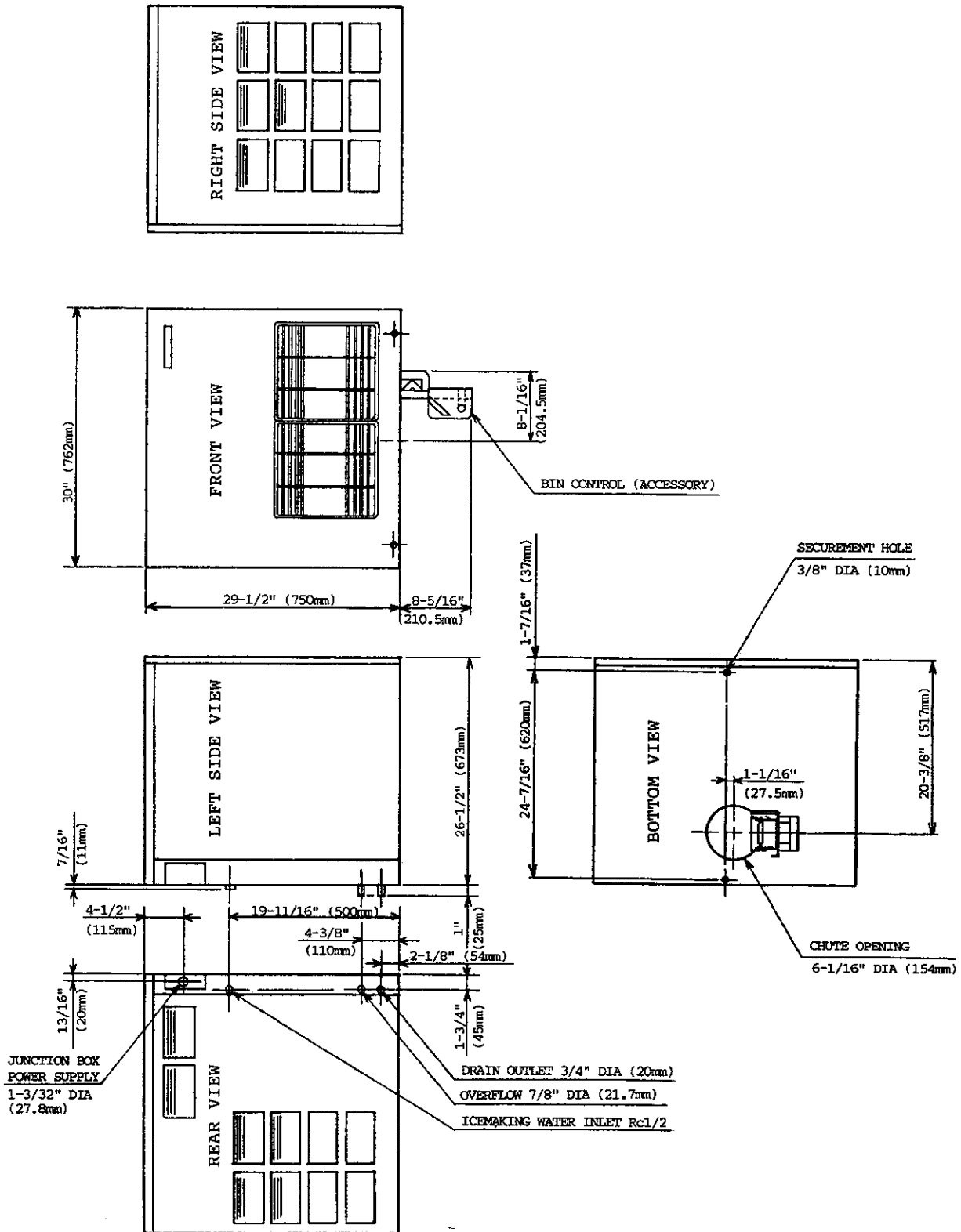

[b] F-1100MWA

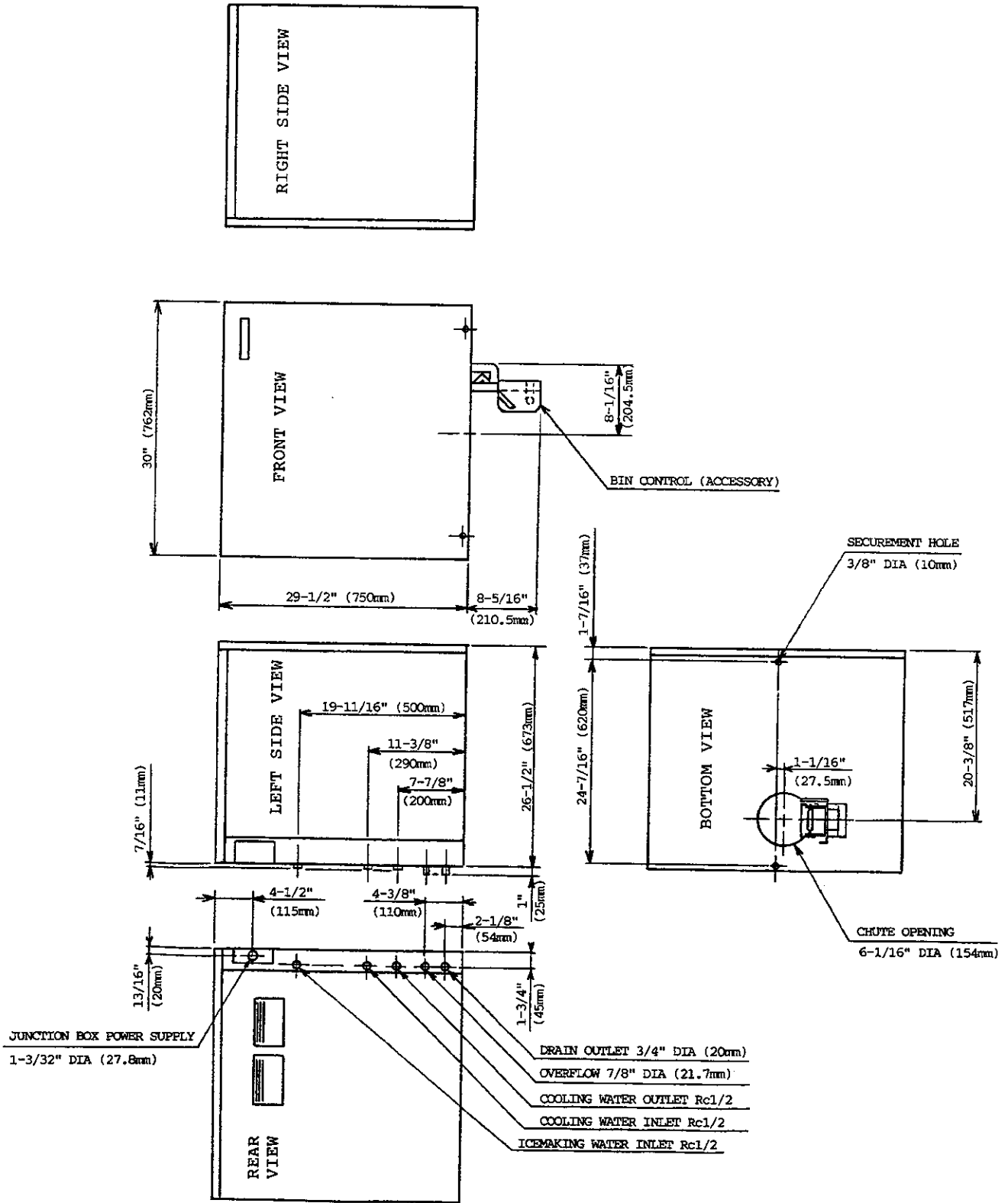

[c] F-1100MRA

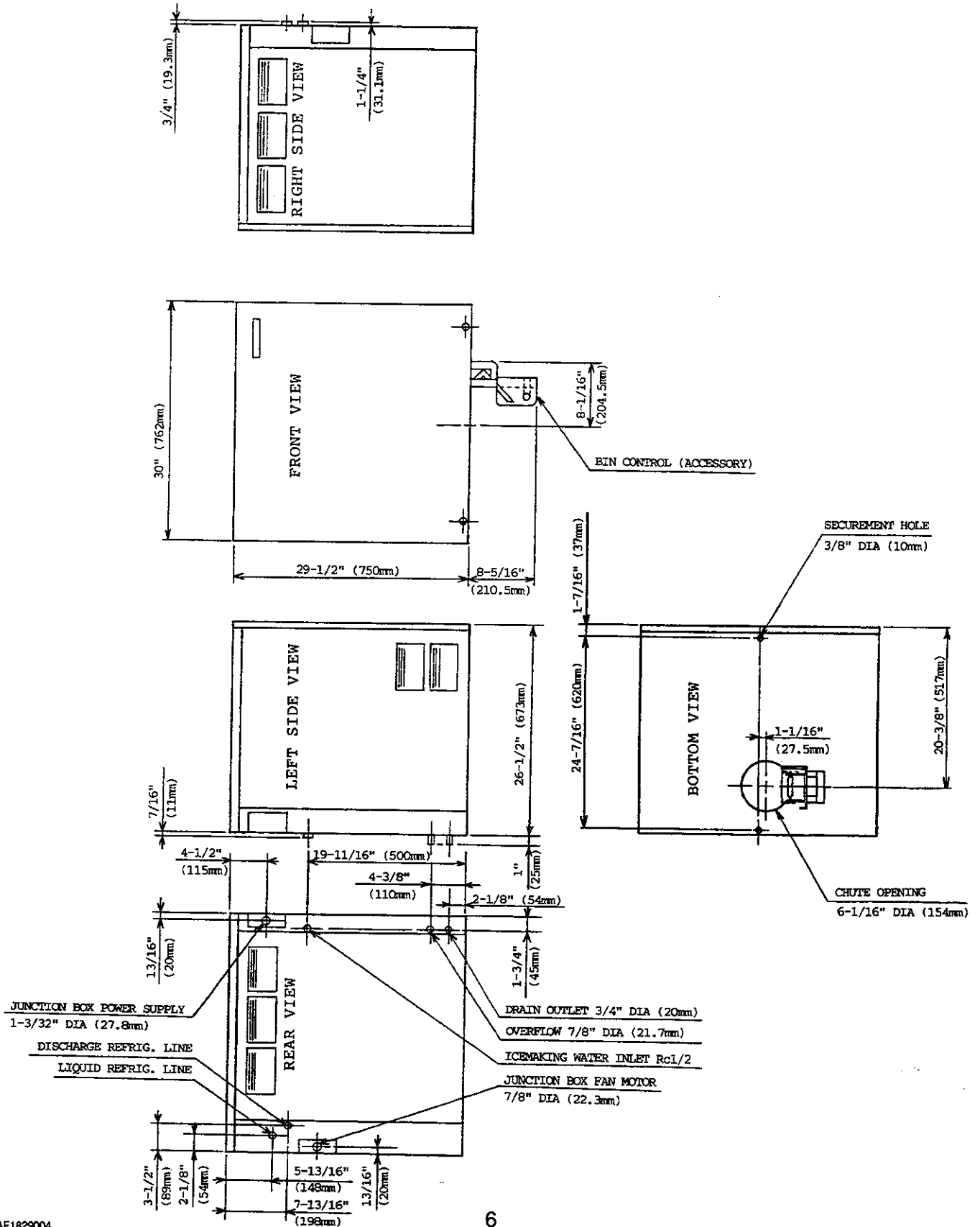

[d] WITH STORAGE BIN

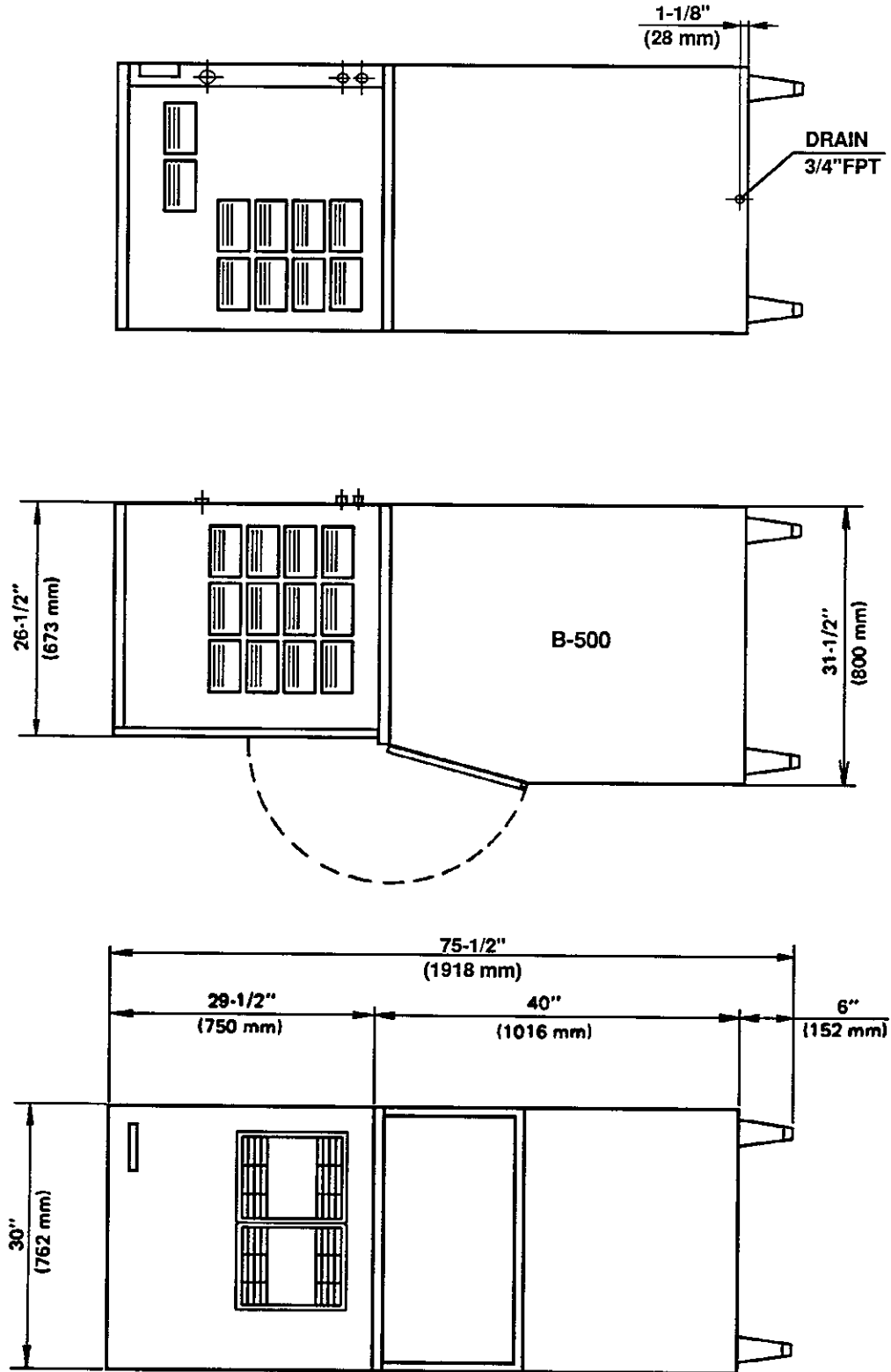

3. SPECIFICATIONS

[a] F-1100MAA

AC SUPPLY VOLTAGE	230-240/60/1 (3 wire with neutral for 115 V)																									
AMPERAGE	6.4 A (AT 104 ° F/ WT 80 ° F)																									
MINIMUM CIRCUIT AMPACITY	15 A																									
MAXIMUM FUSE SIZE	15 A																									
APPROXIMATE ICE PRODUCTION PER 24 HR.	<table border="1"> <thead> <tr> <th rowspan="2">Ambient Temp. (° F)</th> <th colspan="3">Water Temp. (° F)</th> </tr> <tr> <th>50</th> <th>70</th> <th>90</th> </tr> </thead> <tbody> <tr> <td>70</td> <td>*1105 (501)</td> <td>1005 (456)</td> <td>920 (417)</td> </tr> <tr> <td>80</td> <td>1015 (460)</td> <td>930 (422)</td> <td>865 (392)</td> </tr> <tr> <td>90</td> <td>920 (417)</td> <td>* 855 (388)</td> <td>795 (361)</td> </tr> <tr> <td>100</td> <td>815 (370)</td> <td>750 (340)</td> <td>705 (320)</td> </tr> </tbody> </table>			Ambient Temp. (° F)	Water Temp. (° F)			50	70	90	70	*1105 (501)	1005 (456)	920 (417)	80	1015 (460)	930 (422)	865 (392)	90	920 (417)	* 855 (388)	795 (361)	100	815 (370)	750 (340)	705 (320)
Ambient Temp. (° F)	Water Temp. (° F)																									
	50	70	90																							
70	*1105 (501)	1005 (456)	920 (417)																							
80	1015 (460)	930 (422)	865 (392)																							
90	920 (417)	* 855 (388)	795 (361)																							
100	815 (370)	750 (340)	705 (320)																							
lbs./day (kg/day)	Reference without *marks																									
SHAPE OF ICE	Flake																									
ICE QUALITY	Approx. 75 %, Ice (90 ° F/ 70 ° F Conductivity 100 μ s/cm)																									
APPROXIMATE STORAGE CAPACITY	N/A																									
PERFORMANCE	70 ° F/ 50 ° F	90 ° F/ 70 ° F																								
ELECTRIC CONSUMPTION	1300 W	1380 W																								
WATER CONSUMPTION PER 24 HR.	132 gal.	102 gal.																								
EXTERIOR DIMENSIONS (WxDxH)	30" x 26-1/2" x 29-1/2" (762 x 673 x 750 mm)																									
EXTERIOR FINISH	Stainless Steel, Galvanized Steel (Rear)																									
WEIGHT	Net 265 lbs. (120 kg), Shipping 300 lbs. (136 kg)																									
CONNECTIONS - ELECTRIC	Permanent Connection																									
- WATER SUPPLY	Inlet 1/2" FPT																									
- DRAIN	Outlet Pipe 7/8" DIA , 3/4" DIA																									
ICE MAKING SYSTEM	Auger type																									
HARVESTING SYSTEM	Direct driven Auger (200 W Gear Motor)																									
ICE MAKING WATER CONTROL	Float Switch																									
COOLING WATER CONTROL	N/A																									
BIN CONTROL SYSTEM	Mechanical Bin Control (Proximity Sw.) and Bin Thermostat																									
COMPRESSOR	Hermetic 860 W, Model REK3-0125-PFV																									
CONDENSER	Air-cooled, Fin and Tube type																									
EVAPORATOR	Copper Tube on Cylinder																									
REFRIGERANT CONTROL	Thermostatic Expansion Valve																									
REFRIGERANT CHARGE	R502, 1 lb. 8 oz (680 g)																									
DESIGN PRESSURE	High 400 PSIG, Low 230 PSIG																									
COMPRESSOR PROTECTION	Internal Protector																									
GEAR MOTOR PROTECTION	Manual reset Circuit Breker and Thermal Protector																									
REFRIGERANT CIRCUIT PROTECTION	Auto reset High Pressure Control Switch																									
LOW WATER PROTECTION	Float Switch and Timer																									
BIN CONTROL PROTECTION	Mechanical Spout Control																									
ACCESSORIES - SUPPLIED	Ice Scoop, Spare Fuse, Bin Control Assembly																									
- REQUIRED	Ice Storage Bin																									
OPERATION CONDITIONS	VOLTAGE RANGE	207 - 264 V	104 - 132 V																							
	AMBIENT TEMP.	45 - 100 ° F																								
	WATER SUPPLY TEMP.	45 - 90 ° F																								
	WATER SUPPLY PRESS.	7 - 113 PSIG																								

* We reserve the right to make changes in specifications and design without prior notice.

[b] F-1100MWA

AC SUPPLY VOLTAGE	230-240/60/1		
AMPERAGE	5.5 A (AT 104 ° F/ WT 80 ° F)		
MINIMUM CIRCUIT AMPACITY	15 A		
MAXIMUM FUSE SIZE	15 A		
APPROXIMATE ICE PRODUCTION PER 24 HR.	Ambient Temp. (° F)	Water Temp. (° F)	
lbs./day (kg/day)		50	70
Reference without *marks	70	*1145 (519)	1030 (467)
	80	1130 (513)	1020 (463)
	90	1120 (508)	*1010 (458)
	100	1110 (503)	1000 (454)
SHAPE OF ICE	Flake		
ICE QUALITY	Approx. 75 % Ice (90 ° F/ 70 ° F, Conductivity 100 μ s/cm)		
APPROXIMATE STORAGE CAPACITY	N/A		
PERFORMANCE	70 ° F/ 50 ° F, 90 ° F/ 70 ° F,		
ELECTRIC CONSUMPTION	1240 W	1250 W	
WATER CONSUMPTION PER 24 HR.	779 gal.	1130 gal.	
EXTERIOR DIMENSIONS (WxDxH)	30" x 26-1/2" x 29-1/2" (762 x 673 x 750 mm)		
EXTERIOR FINISH	Stainless Steel, Galvanized Steel(Rear)		
WEIGHT	Net 265 lbs. (120 kg), Shipping 300 lbs. (136 kg)		
CONNECTIONS - ELECTRIC	Permanent Connection		
- WATER SUPPLY	Inlet 1/2" FPT	Condenser Inlet 1/2" FPT	
- DRAIN	Outlet Pipe 7/8"DIA , 3/4"DIA	Condenser Outlet 1/2" FPT	
ICE MAKING SYSTEM	Auger type		
HARVESTING SYSTEM	Direct driven Auger (200 W Gear Motor)		
ICE MAKING WATER CONTROL	Float Switch		
COOLING WATER CONTROL	Water Regulating Valve		
BIN CONTROL SYSTEM	Mechanical Bin Control (Proximity Sw.) and Bin Thermostat		
COMPRESSOR	Hermetic 860 W, Model REK3-0125-PRV		
CONDENSER	Water-cooled, Double tube type		
EVAPORATOR	Copper Tube on Cylinder		
REFRIGERANT CONTROL	Thermostatic Expansion Valve		
REFRIGERANT CHARGE	R502, 1 lb. 1 oz. (480 g)		
DESIGN PRESSURE	High 400 PSIG, Low 230 PSIG		
COMPRESSOR PROTECTION	Internal Protector		
GEAR MOTOR PROTECTION	Manual reset Circuit Breaker and Thermal Protector		
REFRIGERANT CIRCUIT PROTECTION	Auto reset High Pressure Control Switch		
LOW WATER PROTECTION	Float Switch and Timer		
BIN CONTROL PROTECTION	Mechanical Spout Control		
ACCESSORIES - SUPPLIED	Ice Scoop, Spare Fuse, Bin Control Assembly		
- REQUIRED	Ice Storage Bin		
OPERATION CONDITIONS	VOLTAGE RANGE	207 - 264 V	
	AMBIENT TEMP.	45 - 100 ° F	
	WATER SUPPLY TEMP.	45 - 90 ° F	
	WATER SUPPLY PRESS.	7 - 113 PSIG	

* We reserve the right to make changes in specifications and design without prior notice.

[c] F-1100MRA

AC SUPPLY VOLTAGE	230-240/60/1 (3 wire with neutral for 115 V)																									
AMPERAGE	6.4 A (AT 104 °F/ WT 80 °F)																									
MINIMUM CIRCUIT AMPACITY	15 A																									
MAXIMUM FUSE SIZE	15 A																									
APPROXIMATE ICE PRODUCTION PER 24 HR.	<table border="1"> <thead> <tr> <th rowspan="2">Ambient Temp. (°F)</th> <th colspan="3">Water Temp. (°F)</th> </tr> <tr> <th>50</th> <th>70</th> <th>90</th> </tr> </thead> <tbody> <tr> <td>70</td> <td>*1105 (501)</td> <td>1005 (456)</td> <td>920 (417)</td> </tr> <tr> <td>80</td> <td>1015 (460)</td> <td>930 (422)</td> <td>865 (392)</td> </tr> <tr> <td>90</td> <td>920 (417)</td> <td>* 855 (388)</td> <td>795 (361)</td> </tr> <tr> <td>100</td> <td>815 (370)</td> <td>750 (340)</td> <td>705 (320)</td> </tr> </tbody> </table>			Ambient Temp. (°F)	Water Temp. (°F)			50	70	90	70	*1105 (501)	1005 (456)	920 (417)	80	1015 (460)	930 (422)	865 (392)	90	920 (417)	* 855 (388)	795 (361)	100	815 (370)	750 (340)	705 (320)
Ambient Temp. (°F)	Water Temp. (°F)																									
	50	70	90																							
70	*1105 (501)	1005 (456)	920 (417)																							
80	1015 (460)	930 (422)	865 (392)																							
90	920 (417)	* 855 (388)	795 (361)																							
100	815 (370)	750 (340)	705 (320)																							
lbs./day (kg/day)																										
Reference without *marks																										
SHAPE OF ICE	Flake																									
ICE QUALITY	Approx. 75% Ice (90 °F/ 70 °F, Conductivity 100 μ s/cm)																									
APPROXIMATE STORAGE CAPACITY	N/A																									
PERFORMANCE	70 °F/ 50 °F, 90 °F/ 70 °F																									
ELECTRIC CONSUMPTION	1350 W	1400 W																								
WATER CONSUMPTION PER 24 HR.	132 gal.	102 gal.																								
EXTERIOR DIMENSIONS (WxDxH)	30" x 26-1/2" x 29-1/2" (762 x 673 x 750 mm)																									
EXTERIOR FINISH	Stainless Steel, Galvanized Steel (Rear)																									
WEIGHT	Net 265 lbs. (120 kg), Shipping 300 lbs. (136 kg)																									
CONNECTIONS - ELECTRIC	Permanent Connection																									
- WATER SUPPLY	Inlet 1/2" FPT																									
- DRAIN	Outlet Pipe 7/8" DIA , 3/4" DIA																									
- REFRIGERATION	Discharge Line 1-1/16-12 UNF Fitting																									
CIRCUIT	Liquid Line 5/8-18 UNF Fitting																									
ICE MAKING SYSTEM	Auger type																									
HARVESTING SYSTEM	Direct driven Auger (200 W Gear Motor)																									
ICE MAKING WATER CONTROL	Float Switch																									
COOLING WATER CONTROL	N/A																									
BIN CONTROL SYSTEM	Mechanical Bin Control (Proximity Sw.) and Bin Thermostat																									
COMPRESSOR	Hermetic 860 W , Model REK3-0125-PFV																									
CONDENSER	Air-cooled Remote Condenser Unit URC-6A Recommended																									
EVAPORATOR	Copper Tube on Cylinder																									
REFRIGERANT CONTROL	Thermostatic Expansion Valve																									
	Condensing Pressure Regulator on URC-6A																									
REFRIGERANT CHARGE	R502, 6 lbs. 13 oz. (3100 g)																									
	(Icemaker 4 lbs. 10 oz. Cond. unit 2 lbs. 3 oz.)																									
DESIGN PRESSURE	High 400 PSIG, Low 230 PSIG																									
COMPRESSOR PROTECTION	Internal Protector																									
GEAR MOTOR PROTECTION	Manual reset Circuit Breaker and Thermal Protector																									
REFRIGERANT CIRCUIT PROTECTION	Auto reset High Pressure Control Switch																									
LOW WATER PROTECTION	Float Switch and Timer																									
BIN CONTROL PROTECTION	Mechanical Spout Control																									
ACCESSORIES - SUPPLIED	Ice Scoop, Spare Fuse, Bin Control Assembly																									
- REQUIRED	Ice Storage Bin, Condenser Unit, Precharged tubing sets																									
OPERATION CONDITIONS	<table> <tr> <td>VOLTAGE RANGE</td> <td>207 - 264 V</td> <td>104 - 132V</td> </tr> <tr> <td>AMBIENT TEMP.</td> <td colspan="2">45 - 100 °F</td> </tr> <tr> <td>WATER SUPPLY TEMP.</td> <td colspan="2">45 - 90 °F</td> </tr> <tr> <td>WATER SUPPLY PRESS.</td> <td colspan="2">7 - 113 PSIG</td> </tr> </table>			VOLTAGE RANGE	207 - 264 V	104 - 132V	AMBIENT TEMP.	45 - 100 °F		WATER SUPPLY TEMP.	45 - 90 °F		WATER SUPPLY PRESS.	7 - 113 PSIG												
VOLTAGE RANGE	207 - 264 V	104 - 132V																								
AMBIENT TEMP.	45 - 100 °F																									
WATER SUPPLY TEMP.	45 - 90 °F																									
WATER SUPPLY PRESS.	7 - 113 PSIG																									

* We reserve the right to make changes in specifications and design without prior notice.

4. CONDENSER UNIT MODEL URC-6A

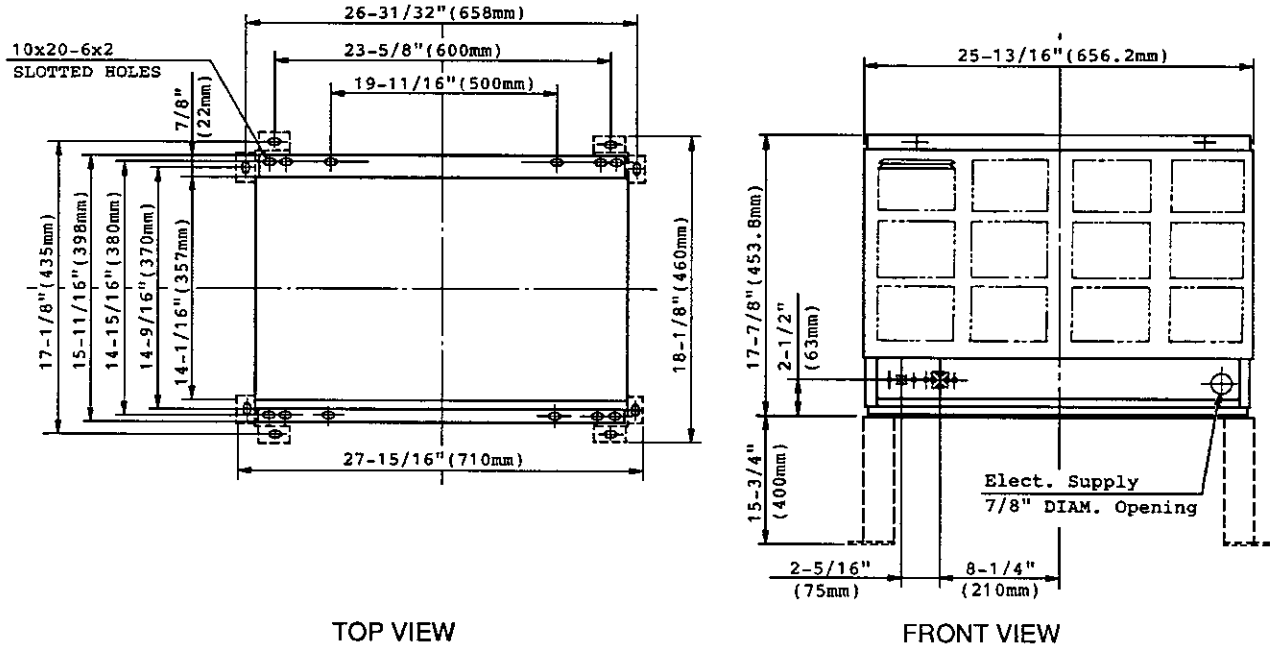

SPECIFICATIONS

MODEL: CONDENSER UNIT URC-6A	
EXTERIOR	Galvanized Steel
DIMENSIONS (H x D x W)	17-7/8" x 15-11/16" x 25-13/16" (453.8 x 398 x 656.2 mm)
REFRIGERANT CHARGE	R502 2 lbs. 3 oz. (1000 g)
WEIGHT	Net 46 lbs. (21 kg) Shipping 53 lbs. (24 kg)
CONNECTIONS REFRIGERANT ELECTRICAL	One Shot Couplings (Aeroquip) Permanent Connection
CONDENSER	Air-cooled
HEAD PRESSURE CONTROL	Condensing Pressure Regulator
AMBIENT CONDITION	Min. -20°F - Max. +122°F (-29°C to +50°C) Outdoor use

II. GENERAL INFORMATION

1. CONSTRUCTION

[a] F-1100MAA

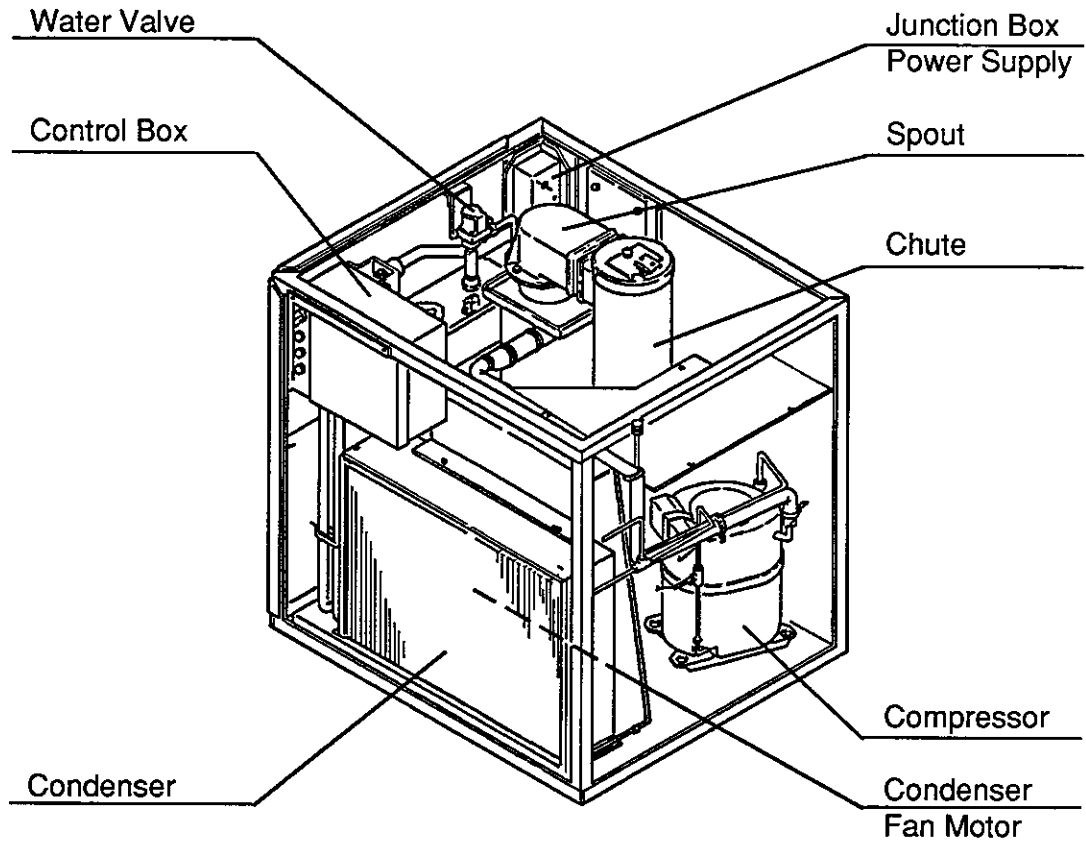

[b] F-1100MWA

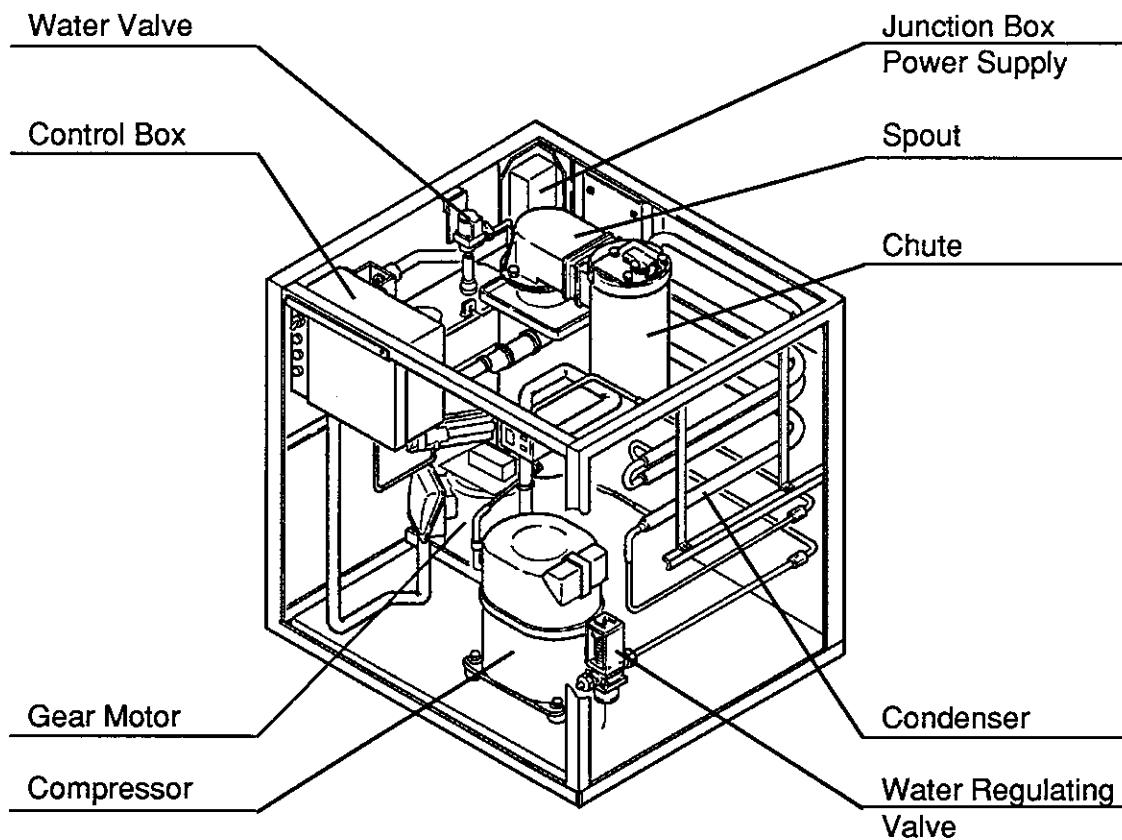

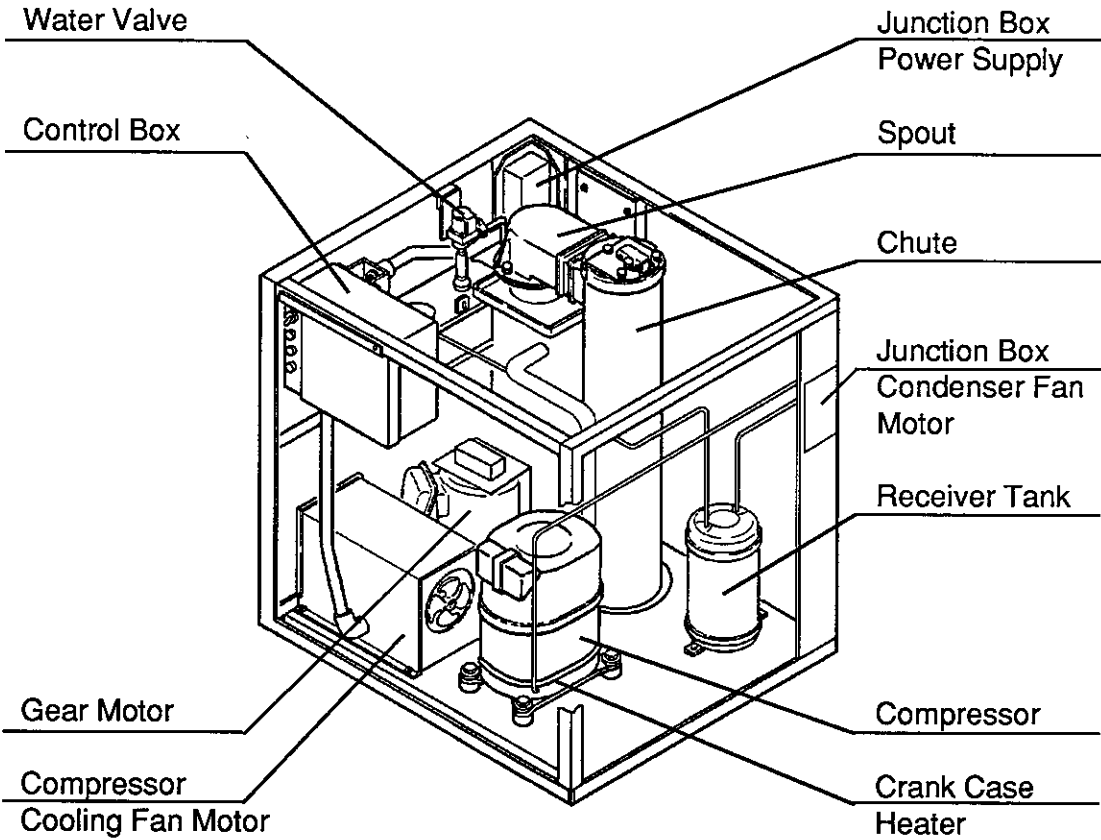

2. CONTROL BOX LAYOUT

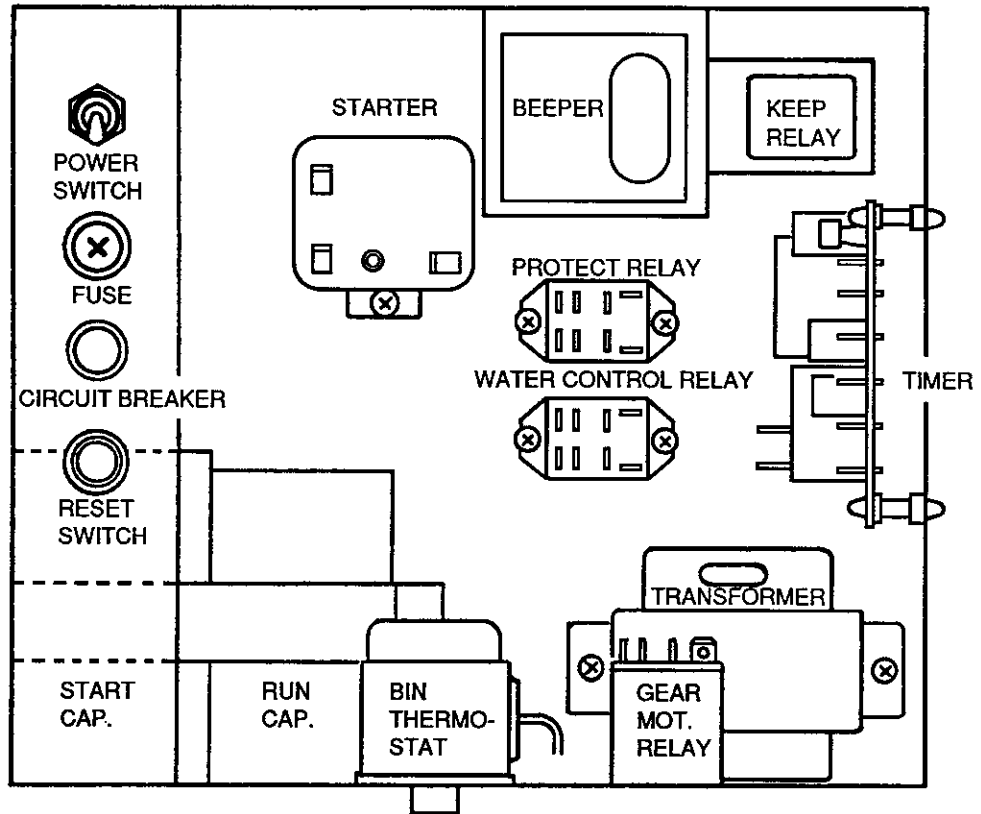

III. INSTALLATION AND OPERATING INSTRUCTIONS

1. CHECKS BEFORE INSTALLATION

WARNING

Remove shipping carton, tapes and packing. If packing material is left in the icemaker, it will not work properly.

- 1) Remove the Front, Top and Side Panels to prevent damage when installing the icemaker. (See "2. HOW TO REMOVE PANELS.")
- 2) Remove the package containing the accessories inside the icemaker.
- 3) Remove the protective plastic film from the panels. If the icemaker is exposed to the sun or to heat, remove the film after the icemaker cools.
- 4) Check that the refrigerant lines do not rub or touch lines or other surfaces, and that the fan blade moves freely.
- 5) Check that the compressor is snug on all mounting pads.
- 6) See NAMEPLATE on the Rear Panel, and check that your voltage supplied corresponds with the voltage specified on the Nameplate.
- 7) This icemaker needs a storage bin. The recommended storage bin is HOSHIZAKI ICE STORAGE BIN, Model B-500 series.
- 8) On remote air-cooled models, a remote condenser unit is needed. The recommended remote condenser unit is HOSHIZAKI CONDENSER UNIT, Model URC-6A.

2. HOW TO REMOVE PANELS - See Fig. 1

- a) Front Panel.....Remove the two screws.
Lift up and pull toward you.
- b) Top Panel.....Lift up front, push away,
and then lift off.
- c) Side PanelRemove the screw.
Pull slightly toward you, and
lift off.

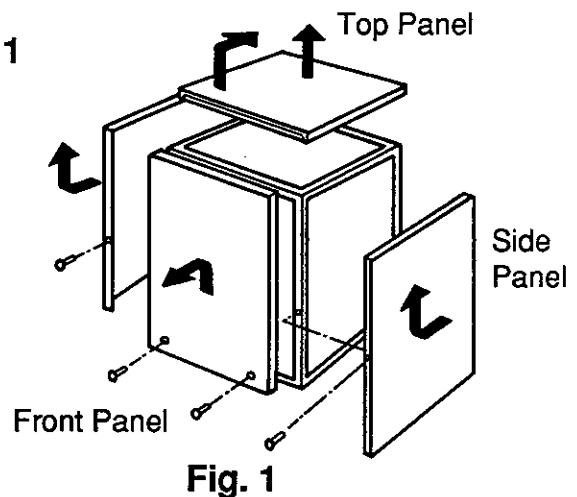

3. LOCATION

WARNING

This icemaker is not designed for unsheltered outdoor installations. Normal operating ambient temperature should be within +45°F to +100°F; Normal operating water temperature should be within +45°F to +90°F. Operation of the icemaker, for extended periods, outside of these normal temperature ranges may affect production capacity

For best operating results:

- * Icemaker should not be located next to ovens, grills or other high heat producing equipment.
- * Location should provide a firm and level foundation for the equipment.
- * Allow 6" clearance at rear and sides for proper air circulation and ease of maintenance and/or service should they be required. Allow 24" clearance at top to allow for removal of the Auger.

4. SET UP

- 1) Unpack the Storage Bin, and attach the four adjustable legs provided (bin accessory) to the bottom of the Storage Bin.
- 2) Position the Storage Bin in the selected permanent position.
- 3) Place the icemaker on the top of the Storage Bin.
- 4) Secure the icemaker to the Storage Bin, by using the two bolts provided. See Fig. 2.

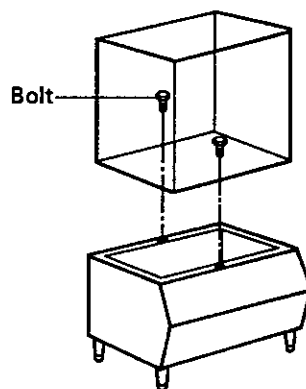

Fig. 2

- 5) Seal the seam between the icemaker and the Storage Bin.
- 6) Level the icemaker/Storage Bin in both the left-to-right and front-to-rear directions. Adjust the legs to make the icemaker level.
- 7) Replace the Top Panel and the Front Panel in their correct position, and secure the Front Panel by two screws.

5. INSTALLATION OF BIN CONTROL - See Fig. 3

- 1) Remove the truss head machine screw securing the bracket for Bin Control Assembly at the bottom of the icemaker.
- 2) Put the Bulb of Bin Thermostat into the Storage Bin through 3/8" dia. hole near the Chute Opening.
- 3) Set the Capillary Packing (accessory) at the hole of the Bottom Panel.
- 4) Put the Bulb of Bin Thermostat through the opening of Bulb Holder.
- 5) Attach the Bin Control Assembly to the Bracket of Bin Control and secure it by using three Thumbscrews (accessory).

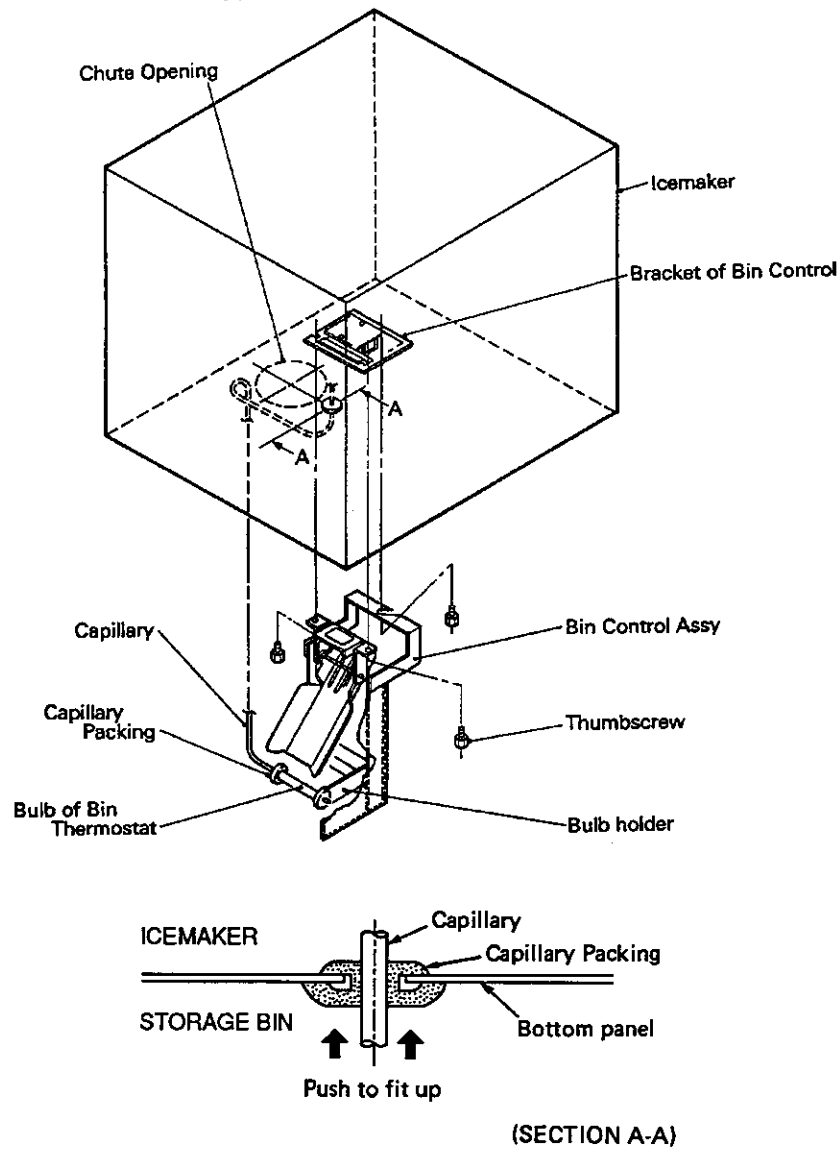

Fig. 3

6. ELECTRICAL CONNECTION

Air-cooled Model F-1100MAA and Remote Air-cooled Model F-1100MRA require 230-240/60/1 (single phase three wire), and Water-cooled Model F-1100MWA requires 230-240/60/1 (single phase two wire).

WARNING

1. Electrical connection must be made in accordance with the instructions on a "WARNING" tag, provided with the pig tail leads in the Junction Box. (except Water-cooled Model)
2. This icemaker requires a ground that meets the national and local electrical code requirements. To prevent possible electrical shock to individuals or extensive damage to the equipment, install a proper ground wire to the icemaker.

* A WHITE lead must be connected to the neutral conductor of the power source. Miswiring results in severe damage to the icemaker. See Fig. 4. (except Water-cooled Model)

* This icemaker must have a separate power supply or receptacle of proper capacity. See NAMEPLATE.

* The opening for the power supply connection is 1-3/32" DIA to fit a 3/4" trade size conduit.

* Usually an electrical permit and services of a licensed electrician are required.

WARNING

ELECTRICAL CONNECTION

A white lead must be connected to the neutral conductor of the power source. Miswiring results in severe damage to the icemaker. (See below Fig.)

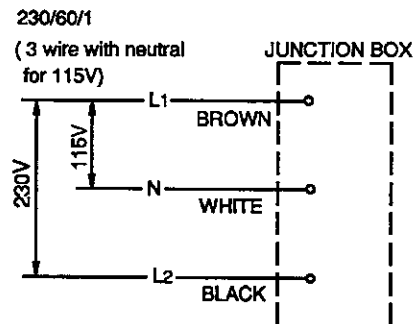

Fig. 4

7. INSTALLATION OF REMOTE CONDENSER UNIT

[a] CHECKS BEFORE INSTALLATION

- 1) Unpack and remove shipping carton, tapes and packing.
- 2) Check that the refrigerant lines do not rub or touch lines or other surfaces, and that the fan blade moves freely.

[b] LOCATION

The condenser unit must be positioned in a permanent site under the following guidelines.

- * A firm and flat site. Use of a roof curb is preferred.
- * A dry and well ventilated area with 24" clearance on both front and rear for ease of maintenance and service should they be required.
- * Normal condenser ambient temperature: -20°F to +122°F. Temperatures not within this operating range may affect the production capacity of the icemaker.
- * The normal refrigerant line length is 66 ft. Should an installation require a longer line length, please call 1-800-233-1940 for recommendations.

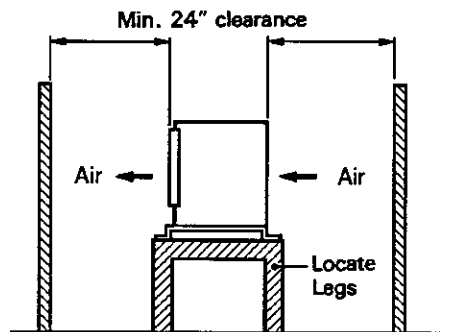

Fig. 5

Note: If the recommended guidelines of the installation are exceeded, the icemaker performance may be reduced.

[c] SET UP

- 1) Secure the Legs to the condenser unit with eight M8 x 16 mm Hexagon Bolts and M8 Nuts as shown in the illustration. (See Fig. 6.)

Note: Locate the Legs symmetrically.

- 2) The Legs have eight mounting holes. Secure the Legs with eight bolts (not included).
- 3) Install enough length of two copper tubings provided with Aeroquip couplings between the icemaker and the condenser unit. The two copper tubings should be insulated separately. (See Fig. 7.)

* Precharged tubing kits, available as optional equipment from HOSHIZAKI AMERICA, are recommended.

- 4) Line sets fabricated in the field should be evacuated through the charging ports on the Aeroquip couplings and charged with R-502 refrigerant vapor to a pressure of 15 - 30 PSIG.

Note: Factory fabricated tubing kits are precharged and do not need to be evacuated.

- 5) Remove the plastic caps protecting the couplings. Attach the two refrigerant lines to the male couplings on the icemaker and the remote condenser unit. Each refrigerant line must be connected as follows:

Icemaker discharge refrigerant line - 3/8" OD tubing to "DIS" of condenser unit

Icemaker liquid refrigerant line - 1/4" OD tubing to "LIQ" of condenser unit

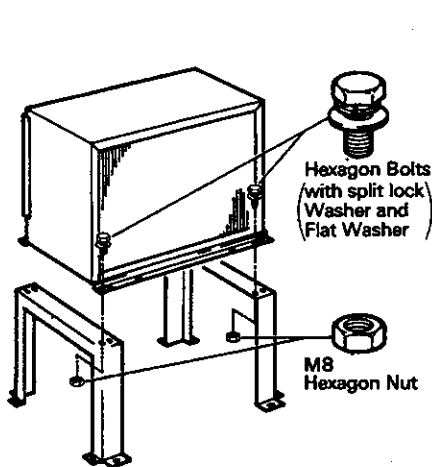

Fig. 6

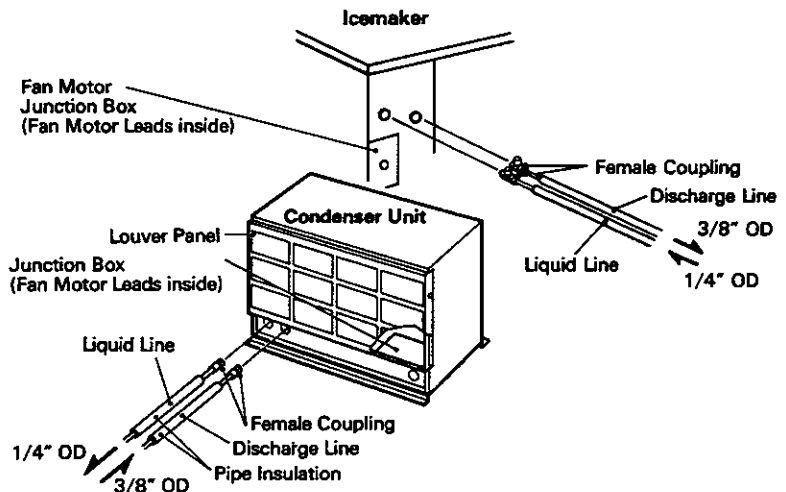

Fig. 7

[d] ELECTRICAL CONNECTION

WARNING

This remote condenser unit requires a ground that meets the national and local electrical code requirements. To prevent possible electrical shock to individuals or extensive damage to equipment, install a proper ground wire to the condenser unit.

- * This condenser unit must be connected to the Fan Motor Junction Box on the icemaker.
- * The opening for the power supply connection is 7/8" DIA to fit a 1/2" trade size conduit.
- * Usually an electrical permit and services of a licensed electrician are required.

- 1) Remove the Louver Panel.
- 2) Remove the Junction Box Cover.
- 3) Connect the Fan Motor leads in the Junction Box of the remote condenser unit to the Fan Motor leads in the Junction Box of the HOSHIZAKI remote air-cooled icemaker.
- 4) Install a ground wire from the icemaker to the remote condenser unit.
- 5) Replace the Junction Box Cover and the Louver Panel in their correct position.

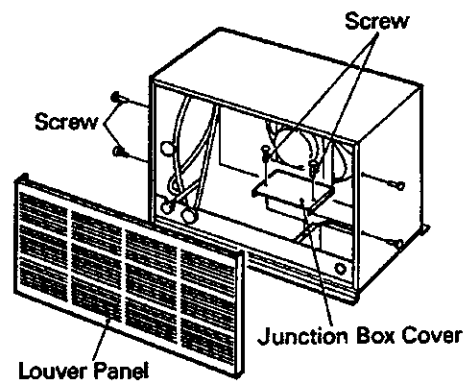

Fig. 8

[e] STACKING CONDENSER UNIT

- 1) Secure the lower condenser unit to the Legs with eight bolts (not included).
- 2) Attach the upper condenser unit on the top of the lower.
- 3) Secure the upper condenser unit with the four screws provided.
- 4) Install refrigerant lines, and make electrical connection for each Fan Motor as shown in Items [c] and [d].

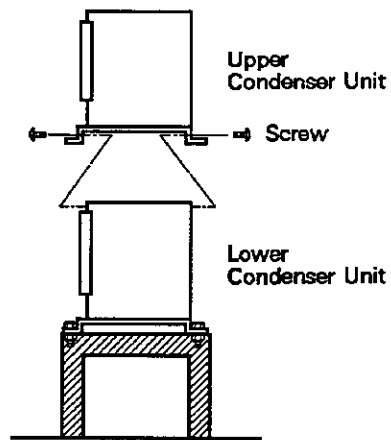

Fig. 9

8. WATER SUPPLY AND DRAIN CONNECTIONS - See Fig. 10

- * External filters, strainers or softeners may be required depending on the water quality.
- * Water supply inlet is 1/2" female pipe thread (FPT).

Note: On water-cooled model, two water supply inlets are provided. One is for the ice making water inlet, and the other is for the cooling water inlet.

- * A water supply line shut-off valve and drain valve should be installed. A minimum of 3/8" OD copper tubing is recommended for the water supply lines.
- * Water supply pressure should be a minimum of 7 PSIG and a maximum of 113 PSIG. If the pressure exceeds 113 PSIG, the use of a pressure reducing valve is required.
- * Drain outlet for icemaking is 3/4" DIA, and overflow is 7/8" DIA. The icemaker drain and the condenser drain piping connections must be made separately from the bin drain.

Note: On water-cooled model, a 1/2" FPT is provided for the Cooling water outlet.

- * The drains must be 1/4" fall per foot on horizontal runs to get a good flow.
- * A plumbing permit and services of a licensed plumber may be required in some areas .

F-1100MAA
F-1100MRA

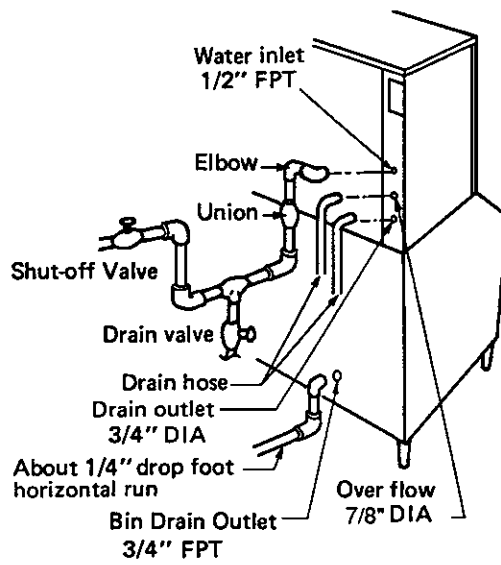

F-1100MWA

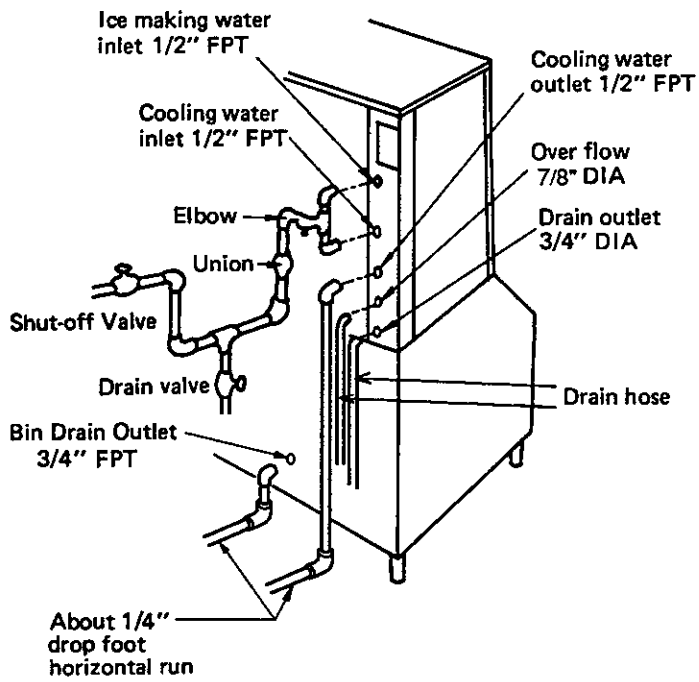

Fig. 10

9. FINAL CHECK LIST

- 1) Is the icemaker level?
- 2) Is the icemaker in a site where the ambient temperature is within +45°F to +100°F and the water temperature within +45°F to +90°F all year around?
- 3) Is there at least 6" clearance around the icemaker for maintenance or service?
- 4) Have all shipping carton, tapes and packing been removed from the icemaker?
- 5) Have all electrical and piping connections been made?
- 6) Has the power supply voltage been checked or tested against the nameplate rating? And has a proper ground been installed in the icemaker?
- 7) Are the Water Supply Line Shut-off Valve and Drain Valve installed? And has the water supply pressure been checked to ensure a minimum of 7 PSIG and a maximum of 113 PSIG?

Note: The icemaker stops running when the water supply is OFF, or if the pressure is below 7 PSIG. When the proper water pressure is reached, the icemaker automatically starts running again.

- 8) Have the compressor hold-down bolts and refrigerant lines been checked against vibration and possible failure?
- 9) Has the Bin Control Switch been checked for correct operation? Move the Activator located on the Bottom Panel of the icemaker. The Compressor should stop in 90 seconds, and the Gear Motor in 150 seconds. Also, when the icemaker is running, hold ice in contact with the Bulb. The Compressor should stop in 100 seconds, and the Gear Motor in 160 seconds.
- 10) Has the end user been given the instruction manual, and instructed on how to operate the icemaker and the importance of the recommended periodic maintenance?
- 11) Has the end user been given the name and telephone number of an authorized service agent?

10. START UP

WARNING

1. All parts are factory-adjusted. Improper adjustments may result in failure.
2. If the unit is turned off, wait for at least 3 minutes before restarting the icemaker to prevent damage to the Compressor.

- 1) Clean the Storage Bin. (See "IV. 2. MAINTENANCE.")
- 2) Open the Water Supply Line Shut-off Valve.
- 3) Turn ON the POWER SWITCH on the Control Box.
- 4) Replace the Side, Top and Front Panels in their correct position.
- 5) Turn on the power supply.

11. PREPARING THE ICEMAKER FOR LONG STORAGE - See Fig. 11

WARNING

When shutting off the icemaker for an extended time, drain out all water from the water line and remove the ice from the Storage Bin. The Storage Bin should be cleaned and dried. Drain the icemaker to prevent damage to the water supply line at sub-freezing temperatures, using a foot or hand pump. Shut off the icemaker until the proper ambient temperature is resumed.

* Air-cooled and Remote Air-cooled Models

- 1) Run the icemaker with the Water Supply Line Shut-off Valve closed.
- 2) Open the Drain Valve and blow out the water inlet line by using air pressure.
- 3) Turn off the power supply.
- 4) Remove the Front Panel and turn OFF the POWER SWITCH on the Control Box.
- 5) Unscrew the cap of the Drain Hose and drain out all water from the water line.
- 6) Replace the cap of the Drain Hose and the Front Panel in their correct position..
- 7) Close the Drain Valve.
- 8) Remove all ice from the Storage Bin, and clean the bin.

* Water-cooled Model

- 1) Turn off the power supply and wait for 3 minutes.
- 2) Turn on the power supply and wait for 20 seconds.
- 3) Close the Water Supply Line Shut-off Valve.
- 4) Open the Drain Valve and quickly blow the water supply line from the Drain Valve to drain water in the Condenser.
- 5) Follow the above steps 3) through 8) in “* Air-cooled and Remote Air-cooled Models.”

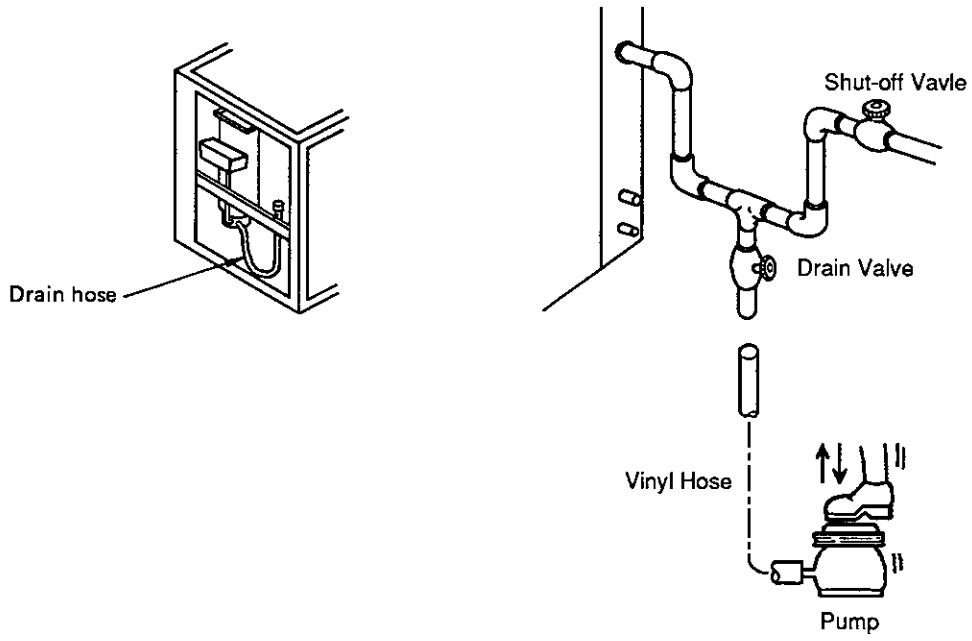

Fig. 11

IV. MAINTENANCE AND CLEANING INSTRUCTIONS

1. CLEANING INSTRUCTIONS

WARNING

1. HOSHIZAKI recommends cleaning this unit at least once a year. More frequent cleaning, however, may be required in some existing water conditions.
2. To prevent injury to individuals and damage to the icemaker, do not use ammonia type cleaners.
3. Always wear liquid-proof gloves for safe handling of the cleaning and sanitizing solution. This will prevent irritation in case the solution contacts with skin.

<STEP 1>

Dilute the solution with water as follows.

Cleaning solution: 6 fl. oz. of recommended cleaner ("LIME-A-WAY," Economics Laboratory, Inc.) with 0.8 gallon of water. This is a minimum amount. Make more solution, if necessary.

Sanitizing solution: 30 fl. oz. of 5.25 % sodium hypochlorite solution with 5 gallons of water.

IMPORTANT

FOR SAFETY AND MAXIMUM EFFECTIVENESS

After dilution, use the solution immediately.

<STEP 2>

Use the cleaning solution to remove lime deposits in the water system.

- 1) Turn off the power supply.
- 2) Close the Water Supply Line Shut-off Valve.
- 3) Remove all ice from the Storage Bin.
- 4) Remove the Front Panel and the Top Panel.

- 5) Unscrew the cap of the Drain Hose, and drain out all water from the water line.
 - 6) Replace the cap of the Drain Hose in its correct position.
 - 7) Remove the cover of the Reservoir.
 - 8) Fill the Reservoir with the cleaning solution.
 - 9) Replace the cover of the Reservoir in its correct position.
- Note: This unit is designed to start operating when the Reservoir is filled with water.
- 10) Turn ON the POWER SWITCH on the Control Box.
 - 11) Replace the Top Panel and the Front Panel in their correct position.
 - 12) Allow the icemaker to set for about 10 minutes before the operation. Then, turn on the power supply, and make ice using the solution until the icemaker stops icemaking.
 - 13) Remove the Front Panel.
 - 14) Drain the cleaning solution. See 5) and 6).
 - 15) Replace the Front Panel in its correct position.
 - 16) Open the Water Supply Line Shut-off Valve, and supply water to the Reservoir.
 - 17) Turn off the power supply when the Gear Motor starts.
 - 18) Drain out all water from the water line. See 4), 5) and 6).

<STEP 3>

Use 3/4 gallons of the sanitizing solution to sanitize the icemaker.

- 1) Close the Water Supply Line Shut-off Valve.
- 2) Remove the cover of the Reservoir.
- 3) Fill the Reservoir with the sanitizing solution.
- 4) Replace the cover of the Reservoir in its correct position.
- 5) Replace the Top Panel and the Front Panel in their correct position.

- 6) Allow the icemaker to set for about 10 minutes before the operation. Then, turn on the power supply, and make ice using the solution until the icemaker stops icemaking.
- 7) Remove the Front Panel.
- 8) Drain the sanitizing solution. See 5) and 6) in STEP 2.
- 9) Replace the Front Panel in its correct position.
- 10) Open the Water Supply Line Shut-off Valve, and supply water to the Reservoir.
- 11) Turn off the power supply when the Gear Motor starts.
- 12) Drain out all water from the water line. See 4), 5) and 6) in STEP 2.

<STEP 4>

Use the sanitizing solution to sanitize removed parts

- 1) Remove the Front Panel and the Top Panel.
- 2) Remove the Thumbscrew and the Chute Cover Assembly.
- 3) Disassemble the Chute Cover Assembly by removing the two Snap Pins, the Axle, the Activator, the two screws and the Plastic Chute Cover.
- 4) Remove the Gasket at the top of the Ice Chute.
- 5) Remove the three Thumbscrews, the Chute Head and the Gasket.
- 6) Remove the Rubber O-ring and the Nylon O-ring at the top of the Cylinder.
- 7) Remove the Ice Chute.

Note: Be sure to remove the Gasket located at the bottom of the Ice Chute.

- 8) Remove the three Thumbscrews and the Bin Control Assembly at the bottom of the icemaker.
- 9) Remove the Bulb of Bin Thermostat and the two Capillary Packings.
- 10) Disassemble the Bin Control Assembly by removing the two Thumbscrews, the Plastic Cover, the Bin Control Bracket, the Snap Pin, the Axle and the Activator.
- 11) Soak or wipe the removed parts.

12) Rinse these parts thoroughly.

IMPORTANT

If the solution is left on these parts, they will rust.

13) Replace the removed parts and the panels.

14) Turn on the power supply and run the icemaker.

15) Turn off the power supply in 30 minutes.

16) Pour warm water into the Storage Bin to melt all ice, and then clean the Bin Liner with the solution.

17) Flush out any solution from the Storage Bin.

18) Turn on the power supply and start the automatic icemaking process.

IMPORTANT

1. After cleaning, **DO NOT** use ice made from the sanitizing solution. Be careful not to leave any solution in the Storage Bin.
2. Follow carefully any instructions provided with the bottles of cleaning or sanitizing solution.
3. Never run the icemaker when the Reservoir is empty.

2. MAINTENANCE

IMPORTANT

This icemaker must be maintained individually, referring to the instruction manual and labels provided with the icemaker.

1) Stainless Steel Exterior

To keep the exterior from corrosion, wipe occasionally with a clean and soft cloth. Use a damp cloth containing a neutral cleaner to wipe off oil or dirt build up.

2) Storage Bin and Scoop

- * Wash your hands before removing ice. Use the plastic scoop provided (Accessory).
- * The Storage Bin is for ice use only. Do not store anything else in the bin.
- * Keep the scoop clean. Clean using a neutral cleaner and rinse thoroughly.
- * Clean the bin liner using a neutral cleaner. Rinse thoroughly after cleaning.

3) Air Filter (Air-cooled model only)

A plastic mesh air filter removes dirt or dust from the air, and keeps the Condenser from getting clogged. As the filter gets clogged, the icemaker's performance will be reduced. Check the filter at least twice a month. When clogged, use warm water and a neutral cleaner to wash the filter.

4) Condenser (Air-cooled model only)

Check the Condenser once a year, and clean if required by using a brush or vacuum cleaner. More frequent cleaning may be required depending on the location of the icemaker.

V. TECHNICAL INFORMATION

1. WATER CIRCUIT AND REFRIGERANT CIRCUIT

[a] F-1100MAA (Air-cooled)

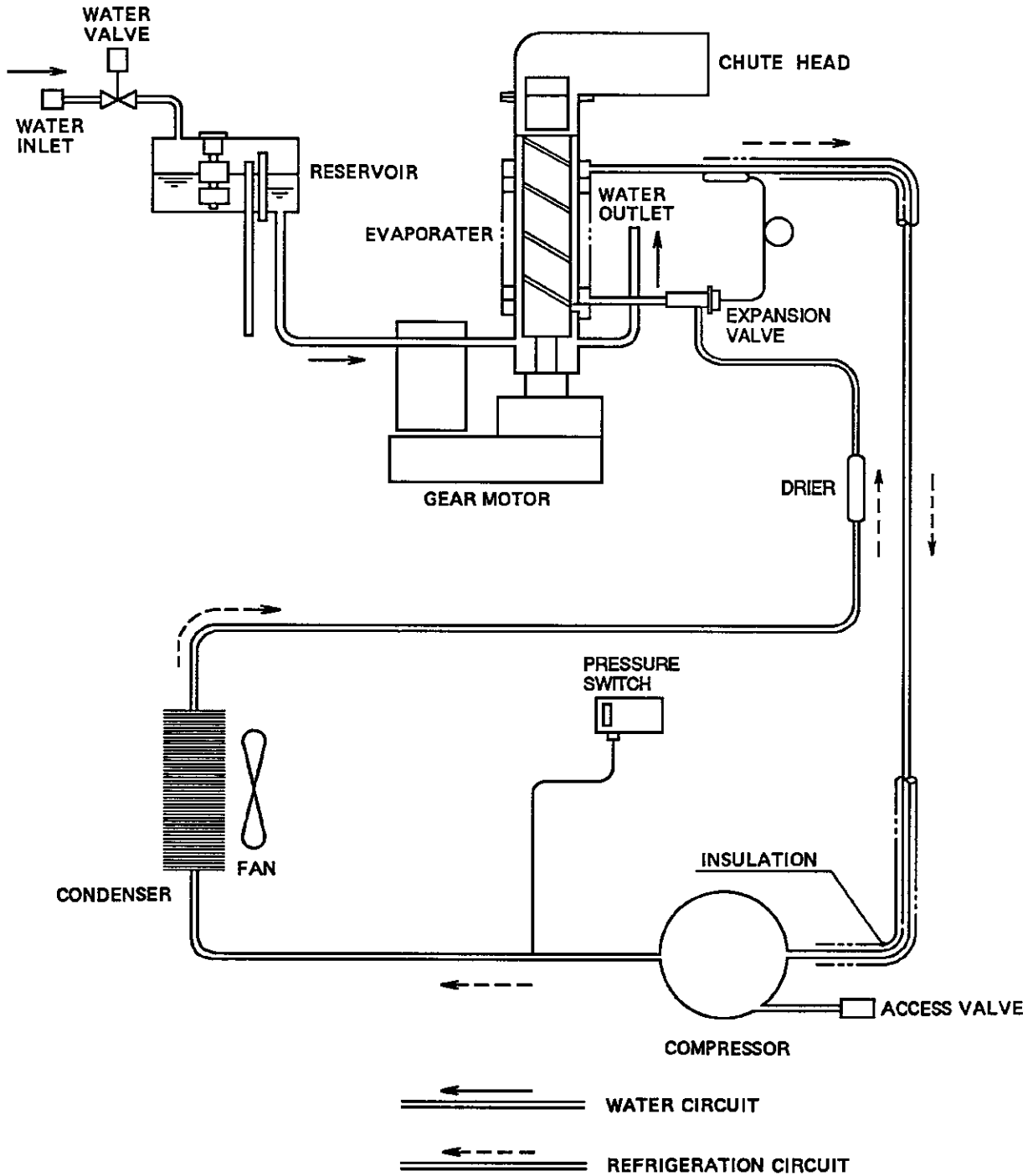

Fig. 12

[b] F-1100MWA (Water-cooled)

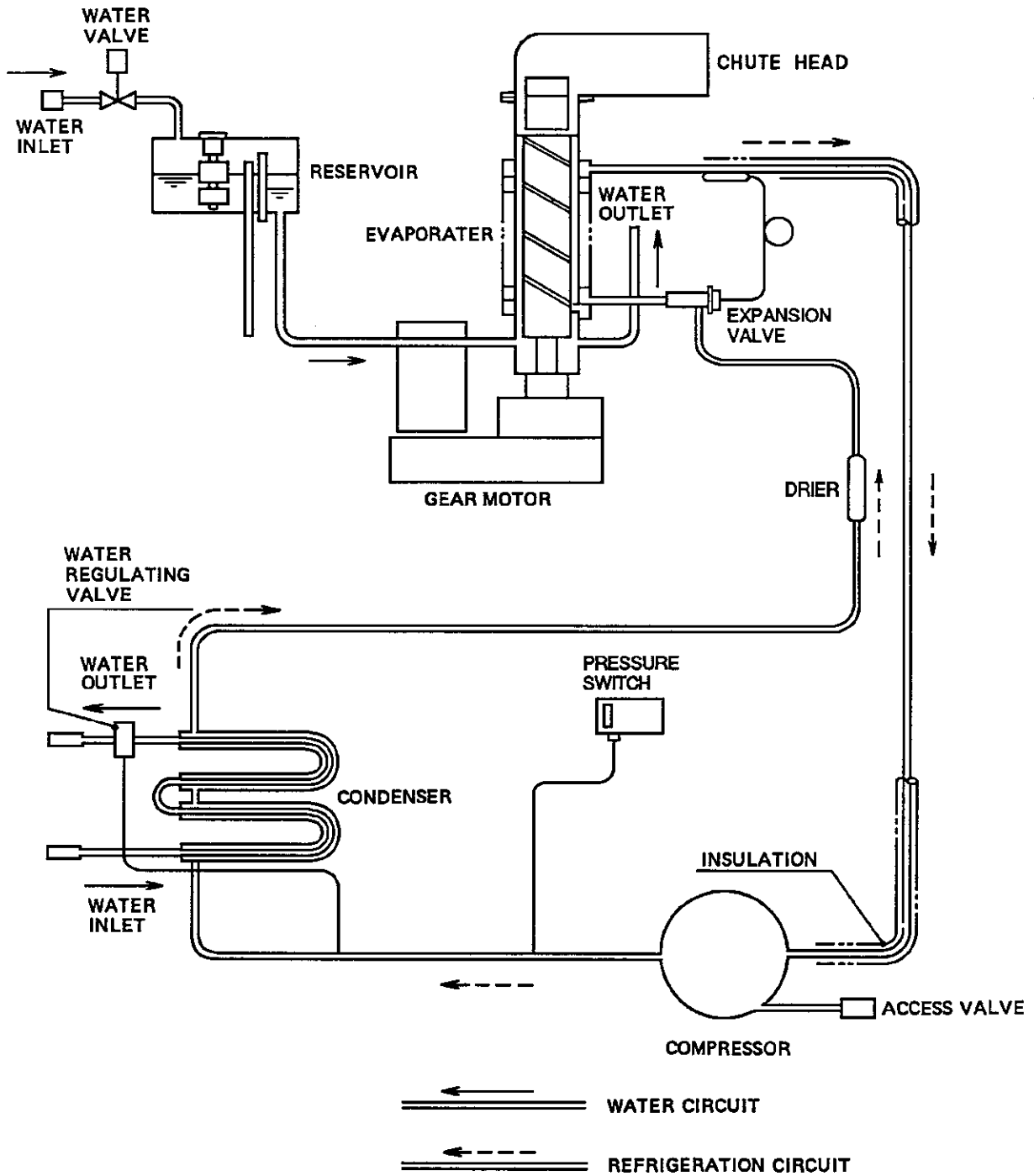

Fig. 13

[c] F-1100MRA (Remote Air-cooled)

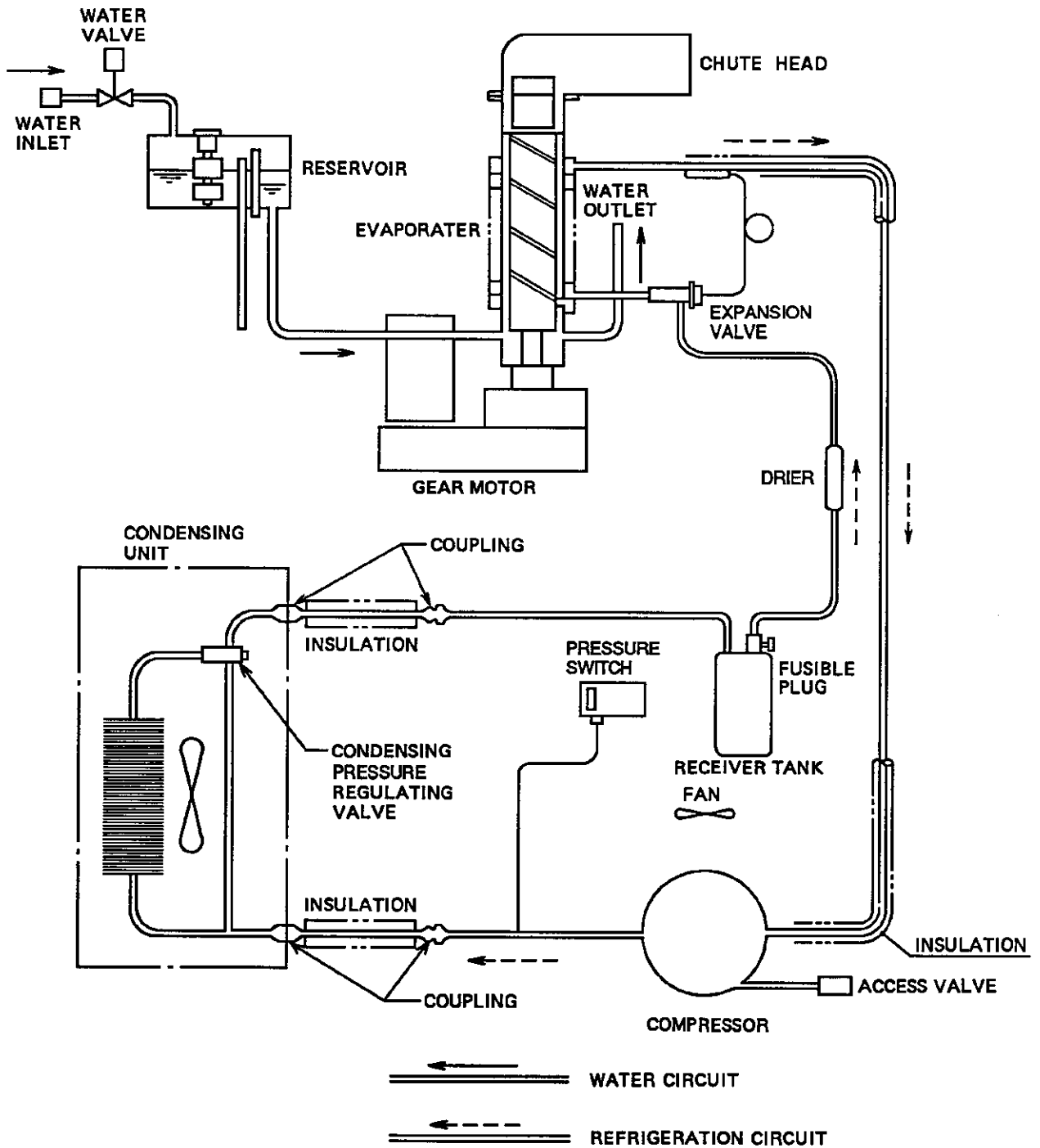

Fig. 14

2. WIRING DIAGRAM

[a] F-1100MAA

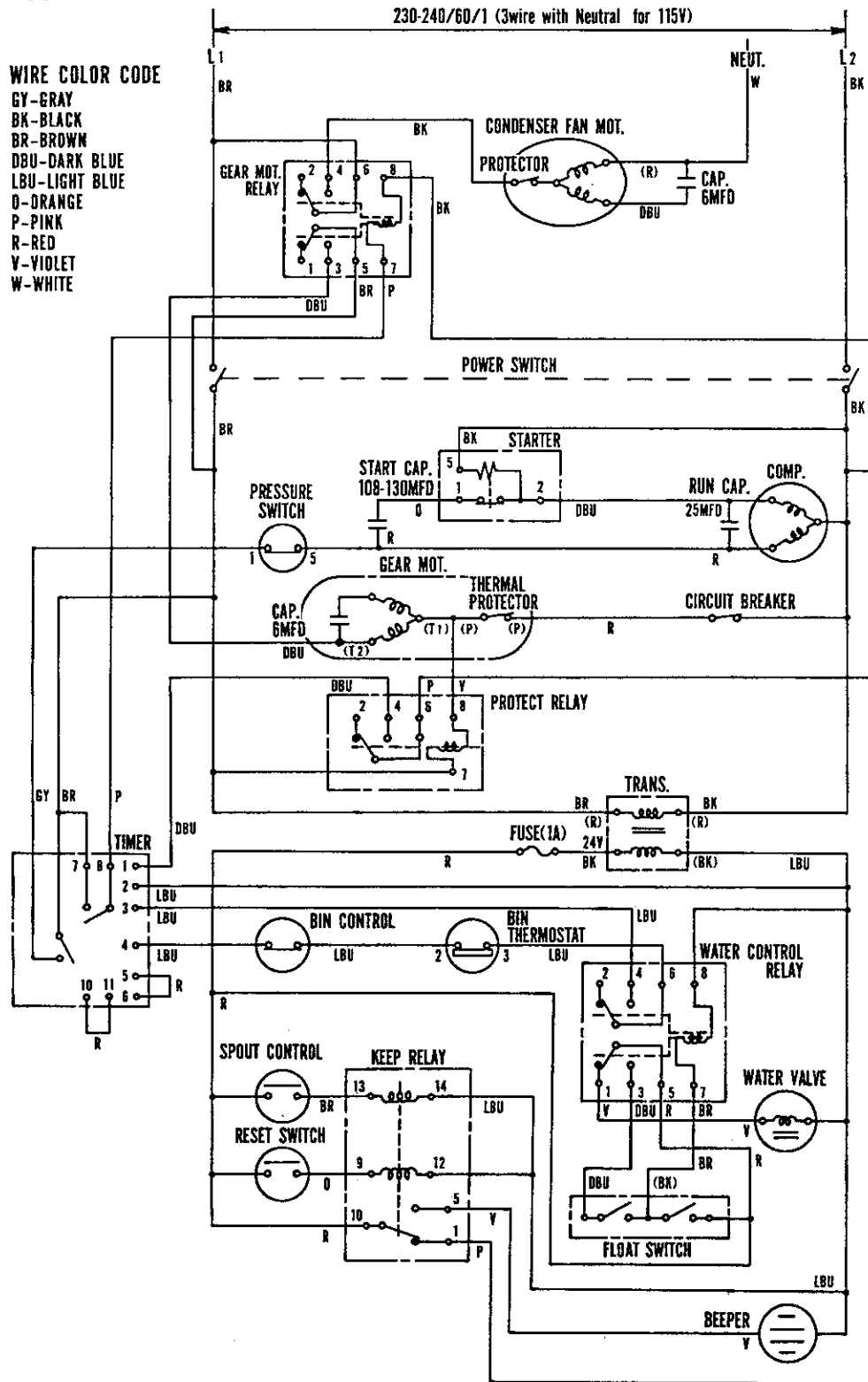

Fig. 15

[b] F-1100MWA

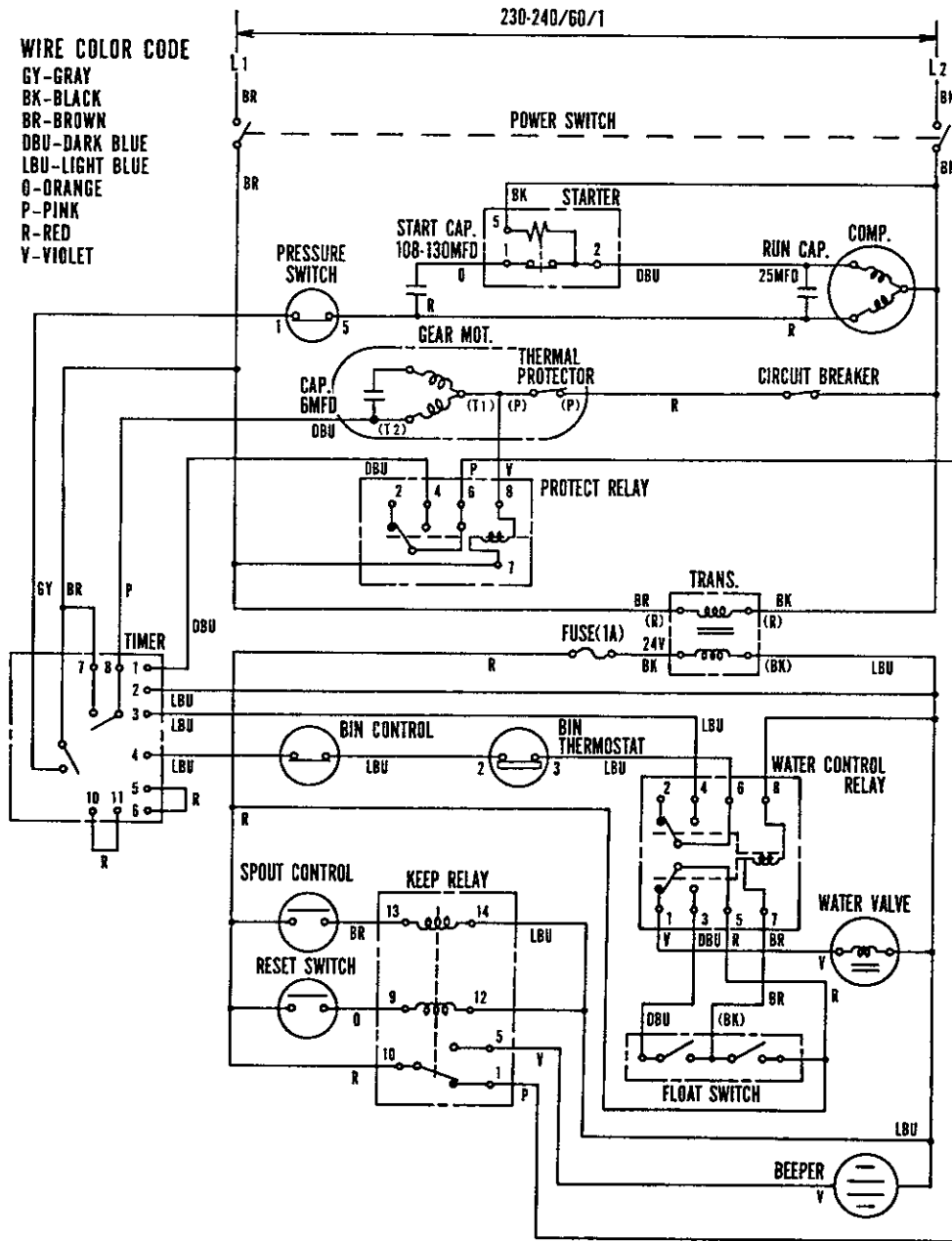

Fig. 16

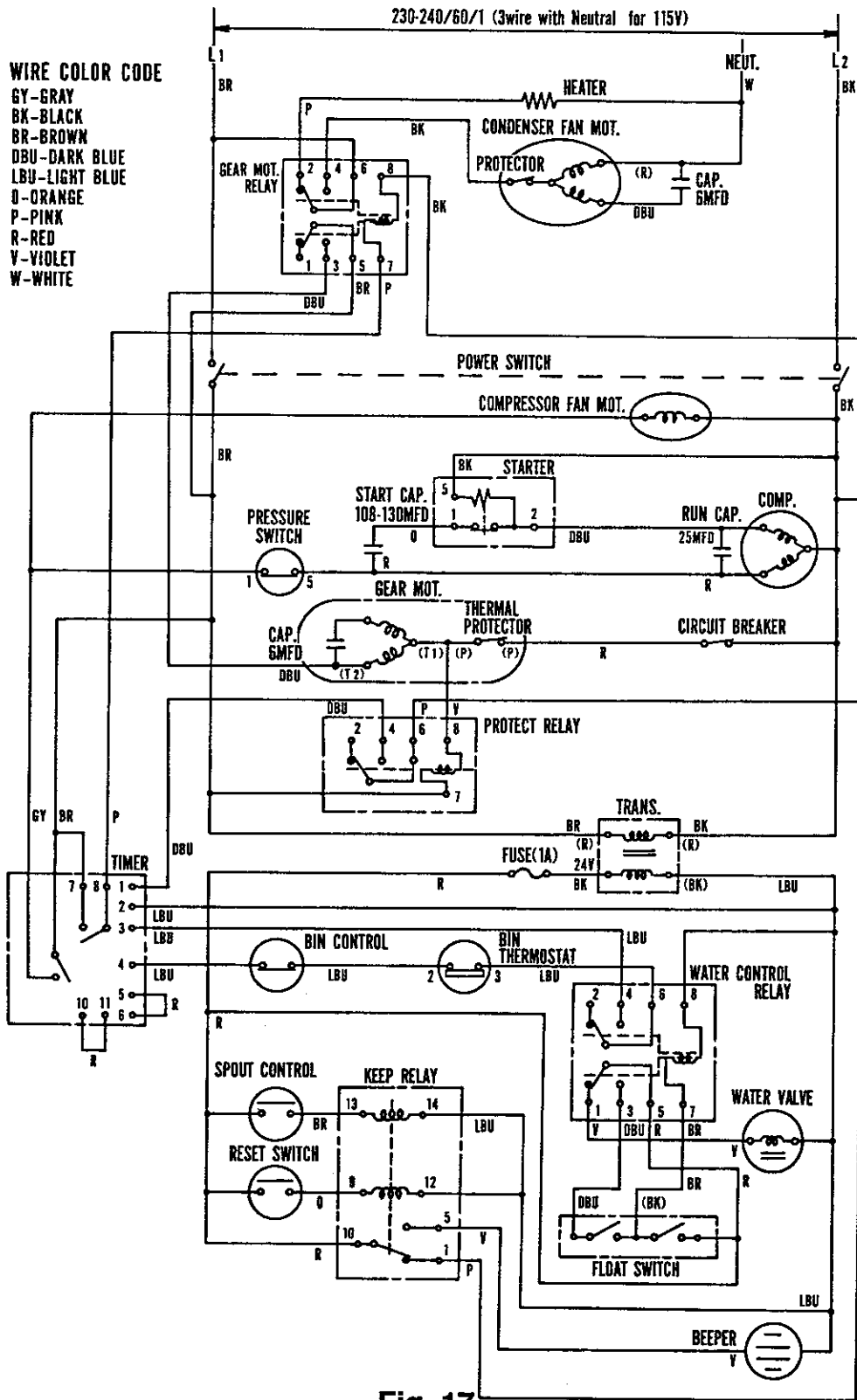

Fig. 17

[d] SEQUENCE OF ELECTRICAL CIRCUITS

a. Turning ON POWER SWITCH starts water supply.

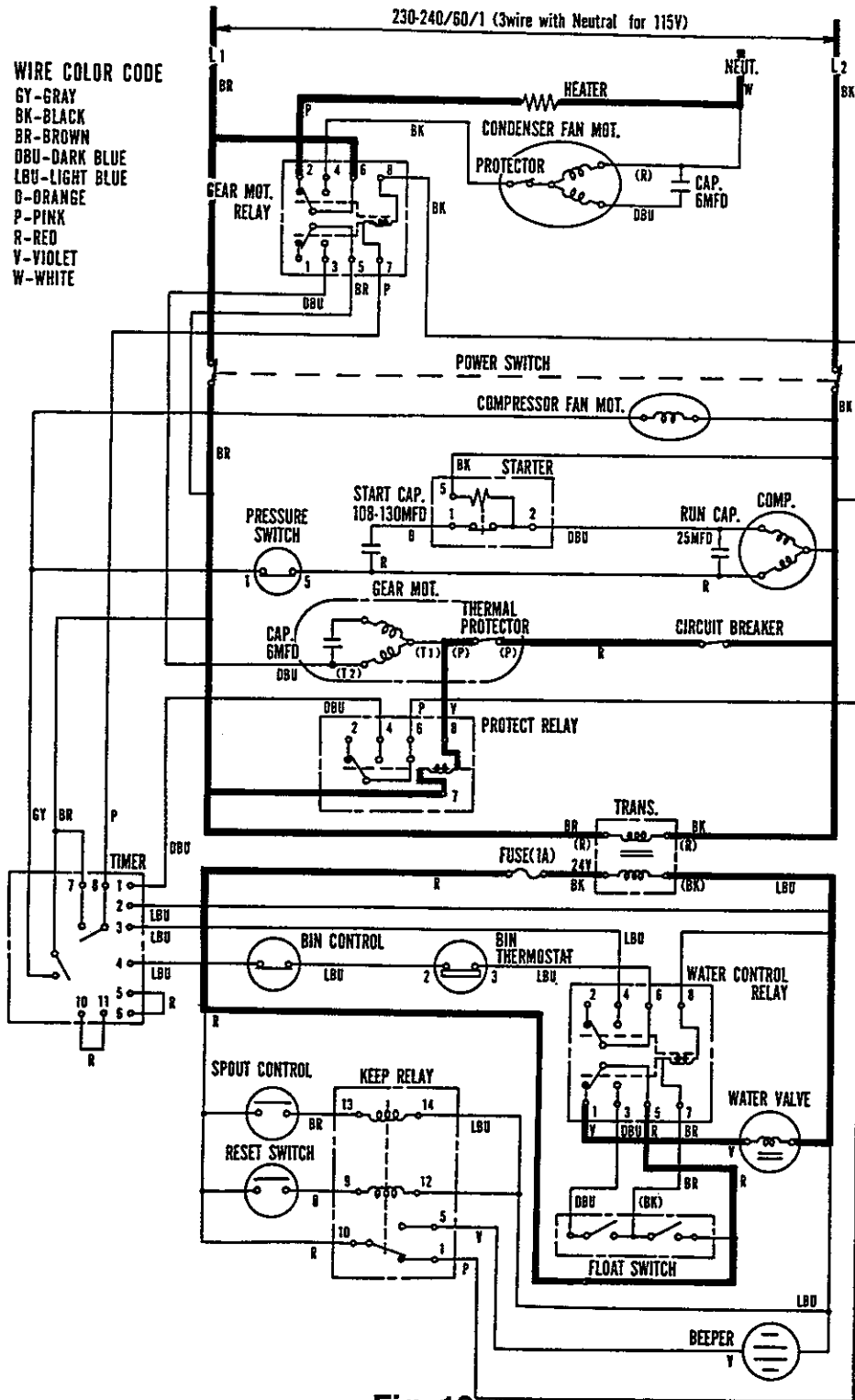

Fig. 18

b. GEAR MOTOR starts just after RESERVOIR has been filled up.

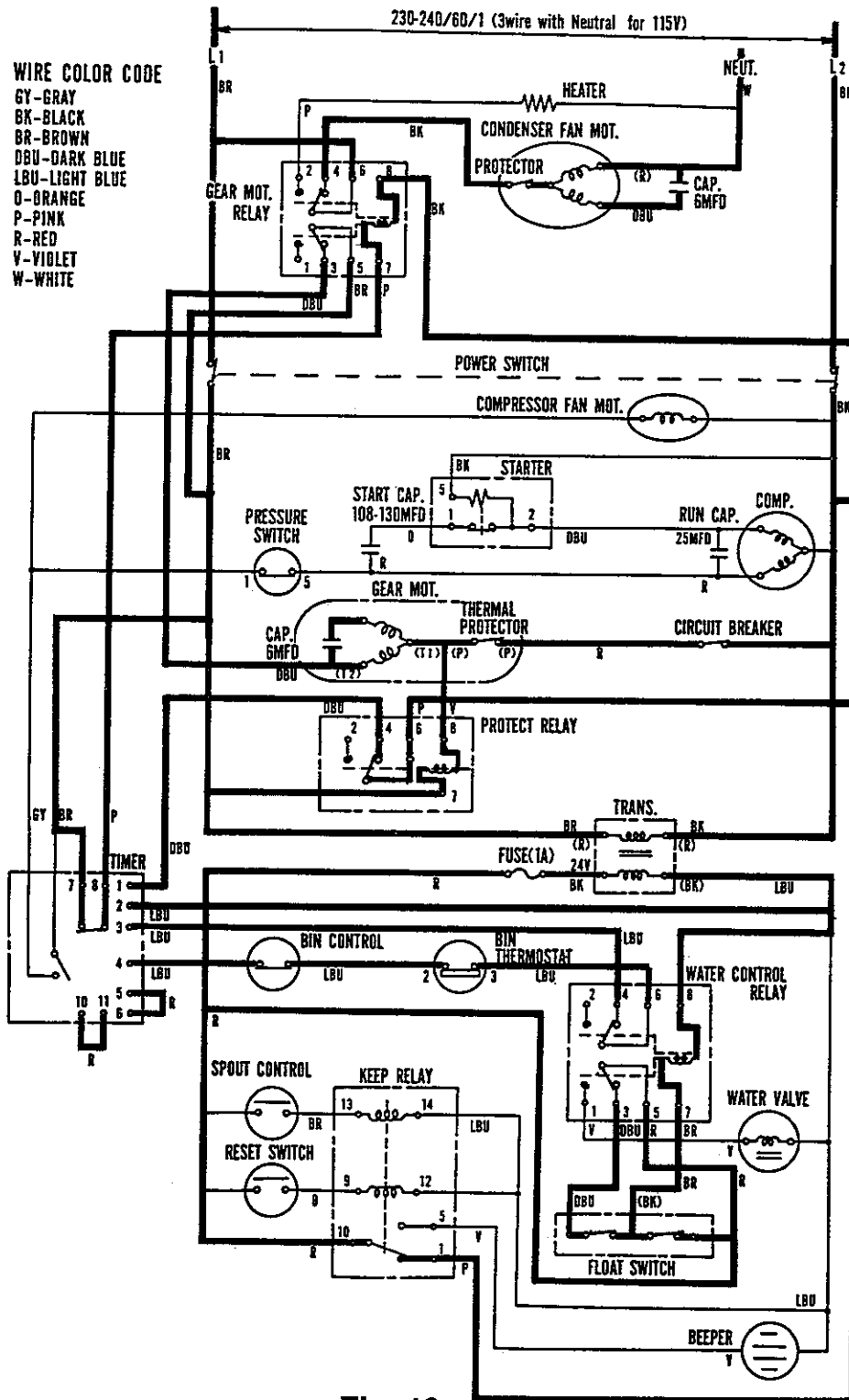

Fig. 19

c. COMPRESSOR starts about 60 sec. after GEAR MOTOR does.

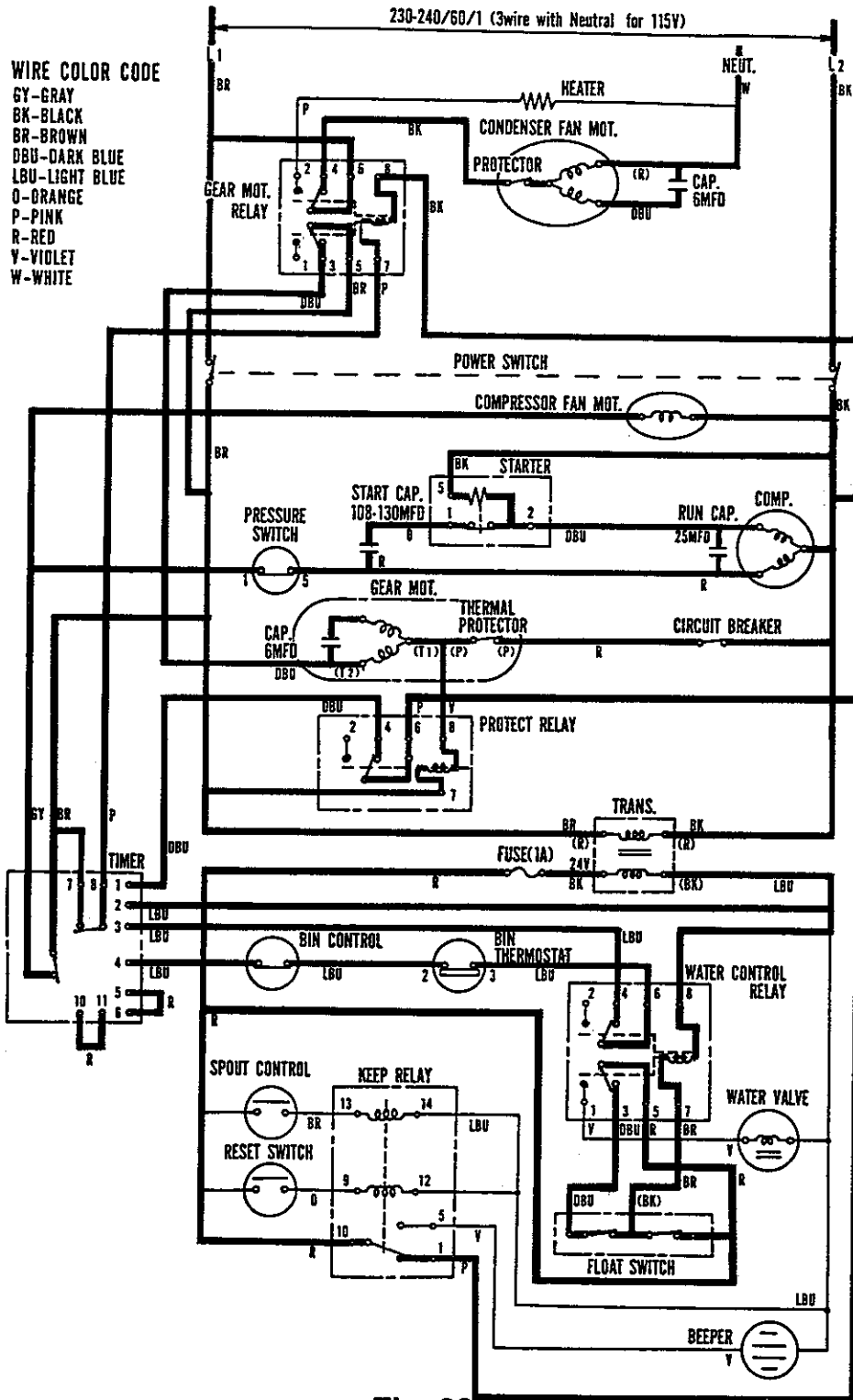

Fig. 20

d. BIN CONTROL operates and COMPRESSOR stops about 90 sec. later.

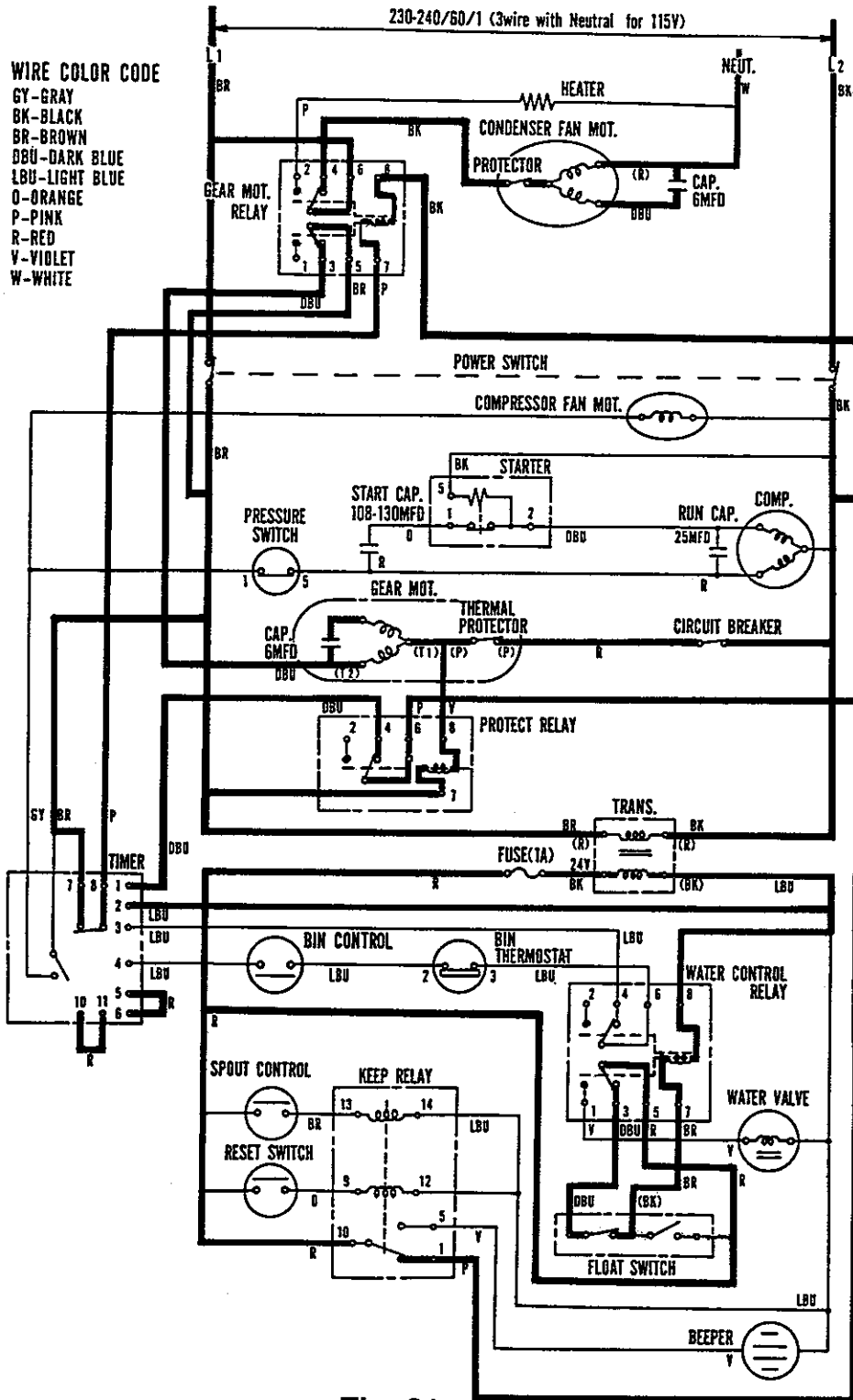

Fig. 21

e. Low Water

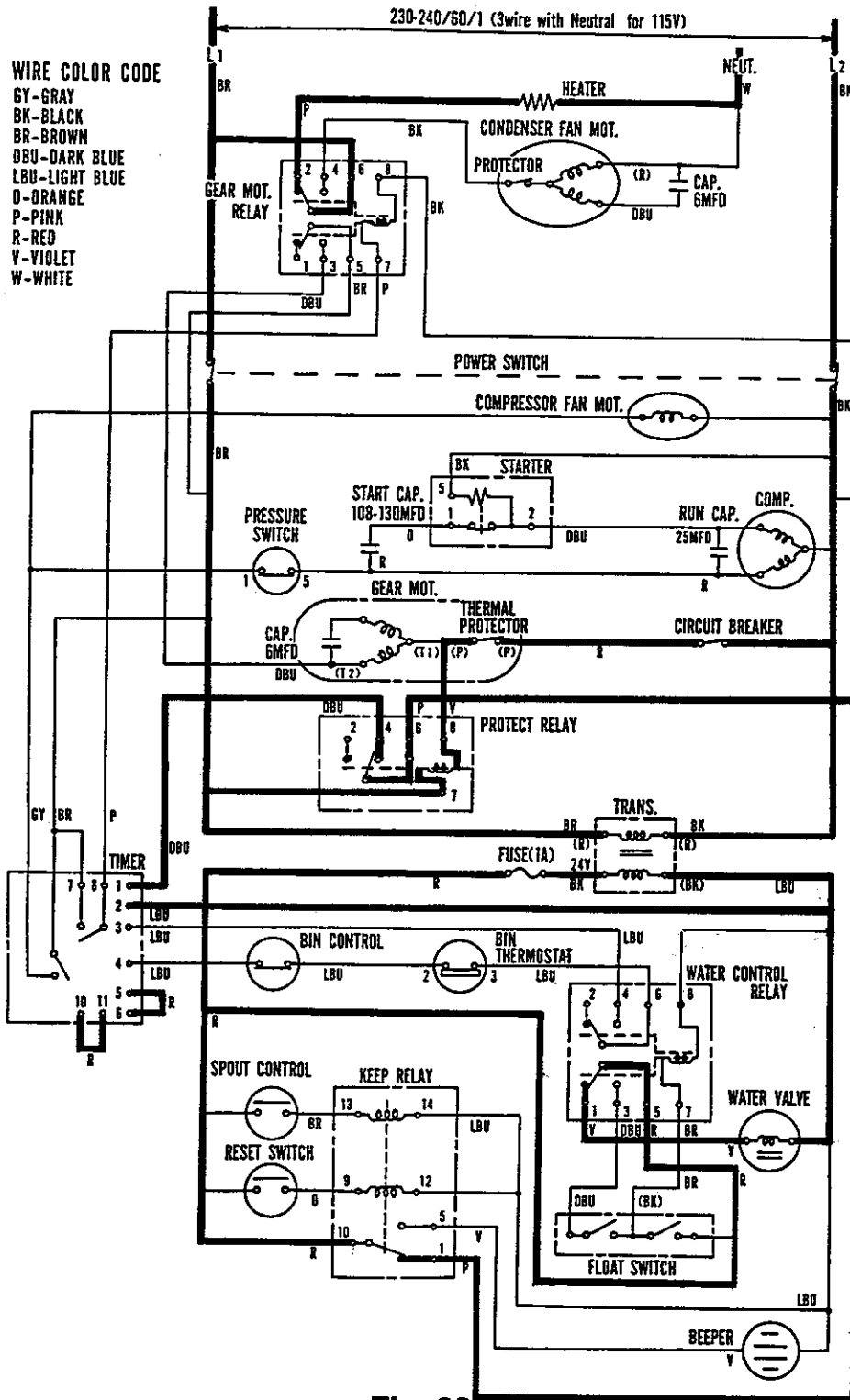

Fig. 22

f. SPOUT CONTROL operates.

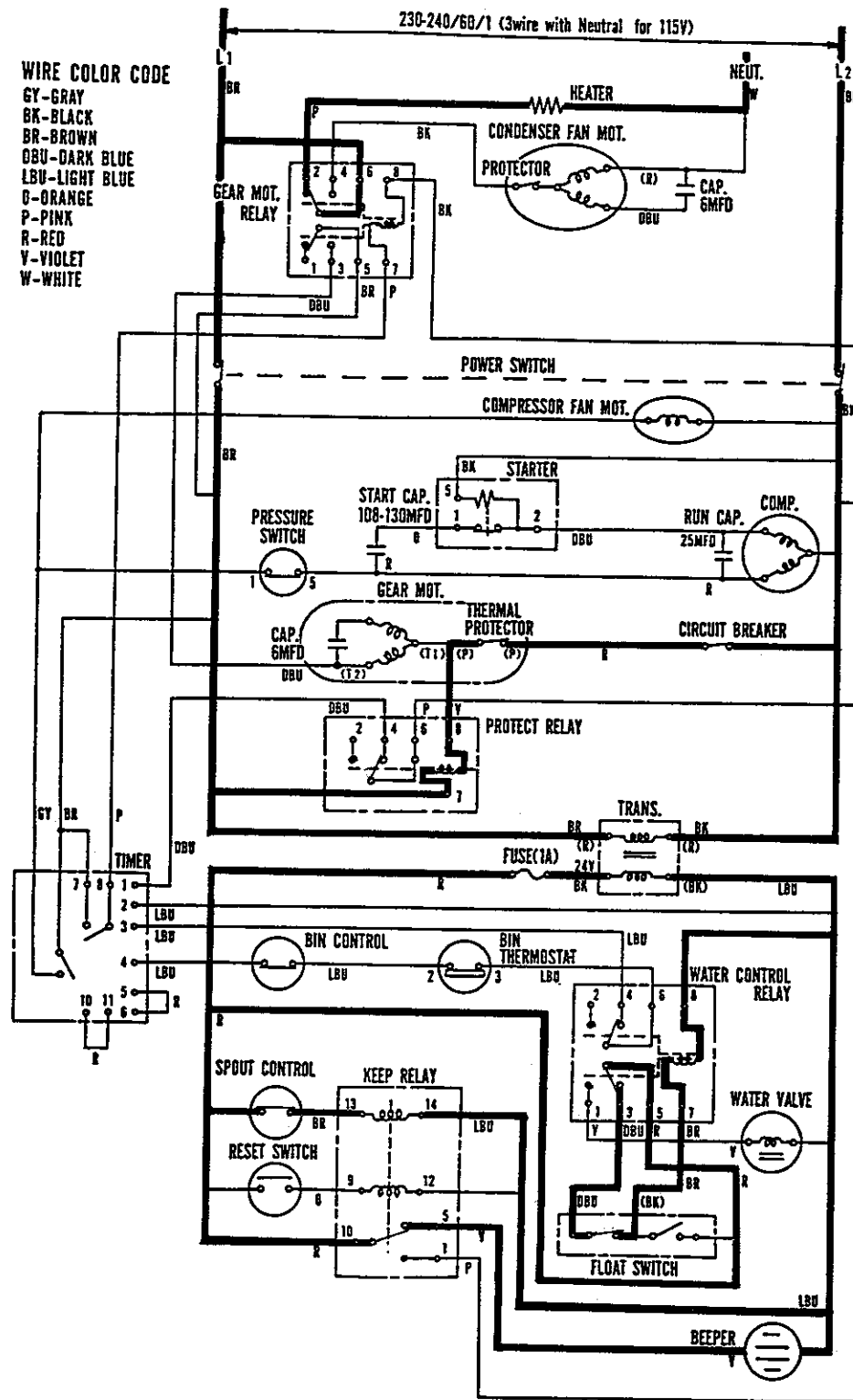

Fig. 23

g. GEAR MOTOR PROTECTOR operates.

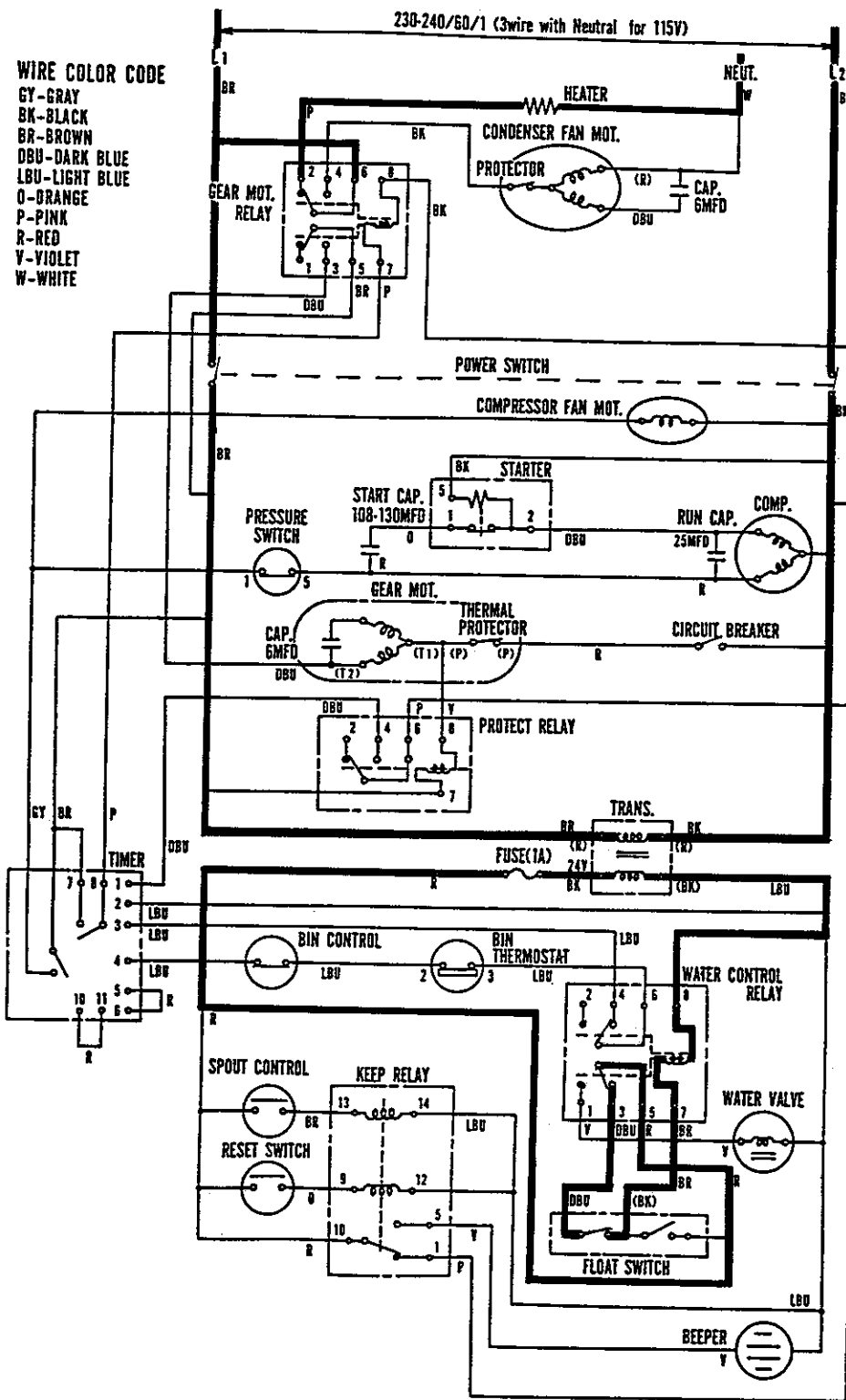
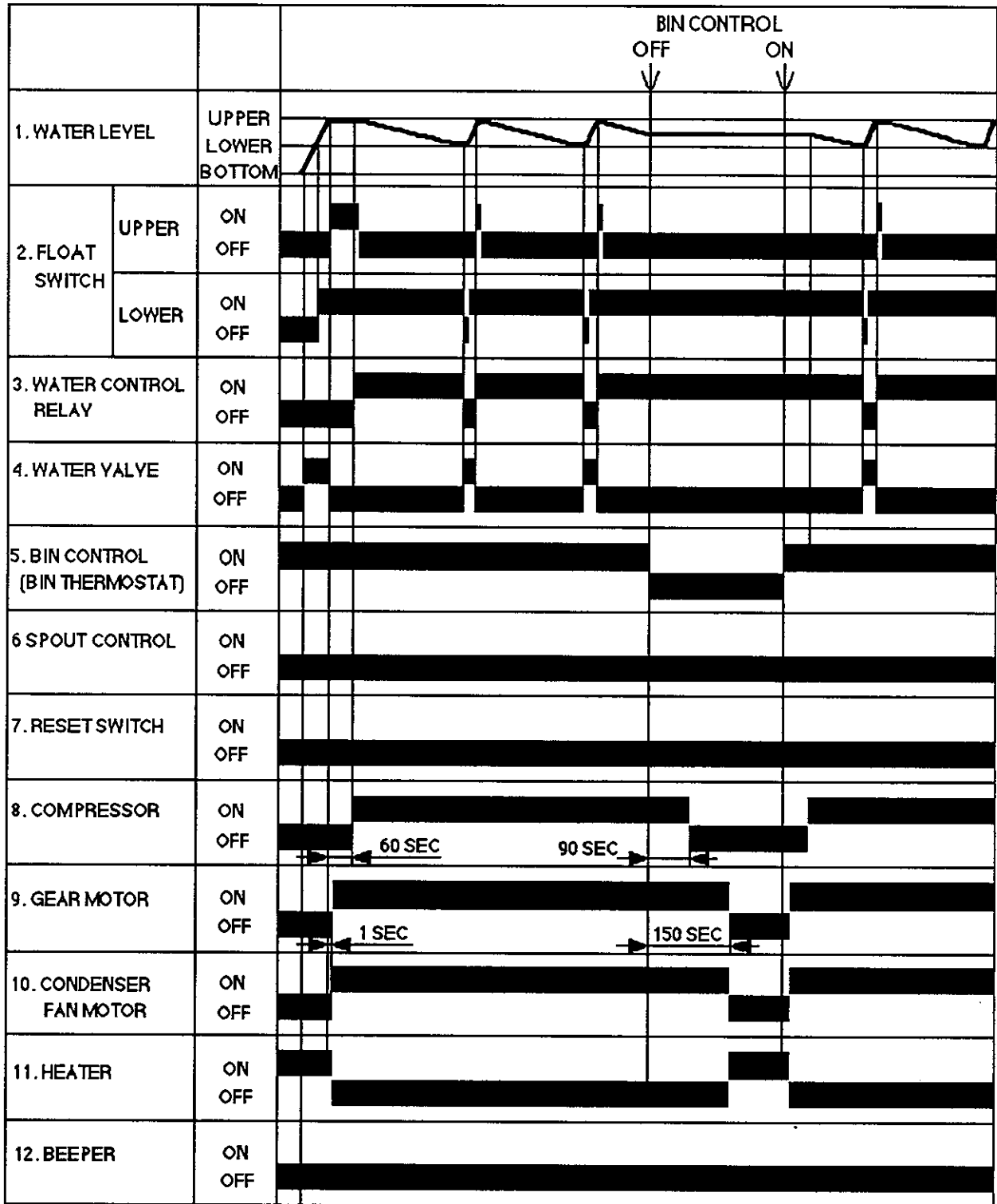
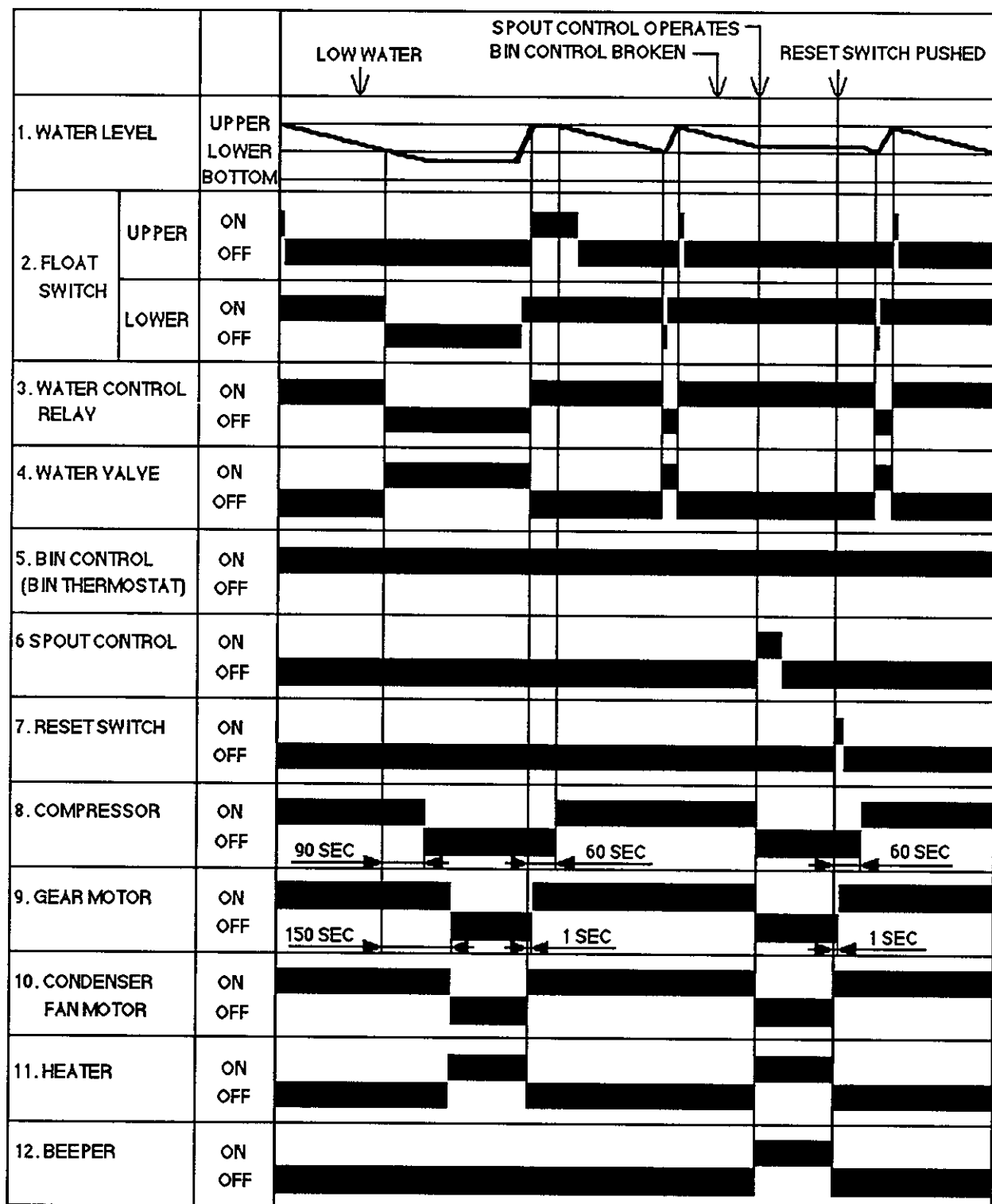

Fig. 24

3. TIMING CHART





4. PERFORMANCE DATA

[a] F-1100MAA

APPROXIMATE ICE PRODUCTION PER 24 HR.	Ambient Temp. (°F)	Water Temp. (°F)		
		50	70	90
lbs./day (kg/day)	70	*1105 (501)	1005 (456)	920 (417)
	80	1015 (460)	930 (422)	865 (392)
	90	920 (417)	* 855 (388)	795 (361)
	100	815 (370)	750 (340)	705 (320)
APPROXIMATE ELECTRIC CONSUMPTION	70	*1300	1330	1330
watts (115/230V)	80	1350	1370	1370
	90	1400	*1380	1390
	100	1400	1400	1400
APPROXIMATE WATER CONSUMPTION PER 24 HR.	70	132 (501)	120 (456)	110 (417)
gal./day (ℓ/day)	80	122 (460)	111 (422)	104 (392)
	90	110 (417)	102 (388)	95 (361)
	100	98 (370)	90 (340)	84 (320)
EVAPORATOR OUTLET TEMP.	70	25 (-4)	25 (-4)	25 (-4)
°F (°C)	80	28 (-2)	28 (-2)	28 (-2)
	90	28 (-2)	28 (-2)	28 (-2)
	100	32 (0)	32 (0)	32 (0)
HEAD PRESSURE	70	200 (14.0)	200 (14.0)	200 (14.0)
PSIG (kg/cm ² G)	80	230 (16.1)	230 (16.1)	230 (16.1)
	90	260 (18.2)	260 (18.2)	260 (18.2)
	100	290 (20.3)	290 (20.3)	290 (20.3)
SUCTION PRESSURE	70	35 (2.45)	36 (2.5)	36 (2.5)
PSIG (kg/cm ² G)	80	36 (2.5)	36 (2.5)	36 (2.5)
	90	37 (2.6)	37 (2.6)	37 (2.6)
	100	39 (2.7)	39 (2.7)	39 (2.7)
TOTAL HEAT OF REJECTION	10070 BTU/h (AT 90 °F/ WT 70 °F)			

Note: The data without *marks should be used for reference.

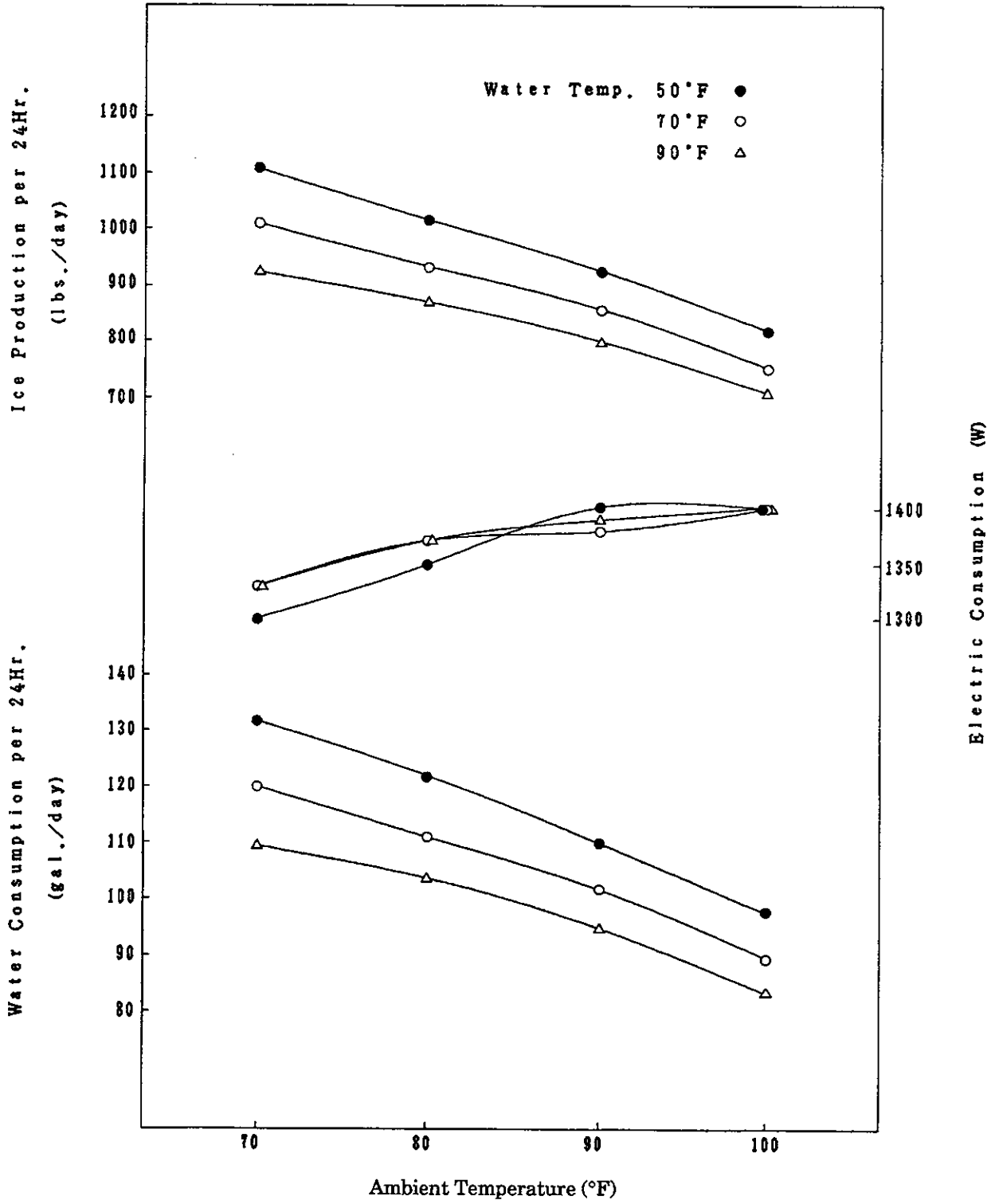

Fig. 25 Performance Data (1) - F-1100MAA

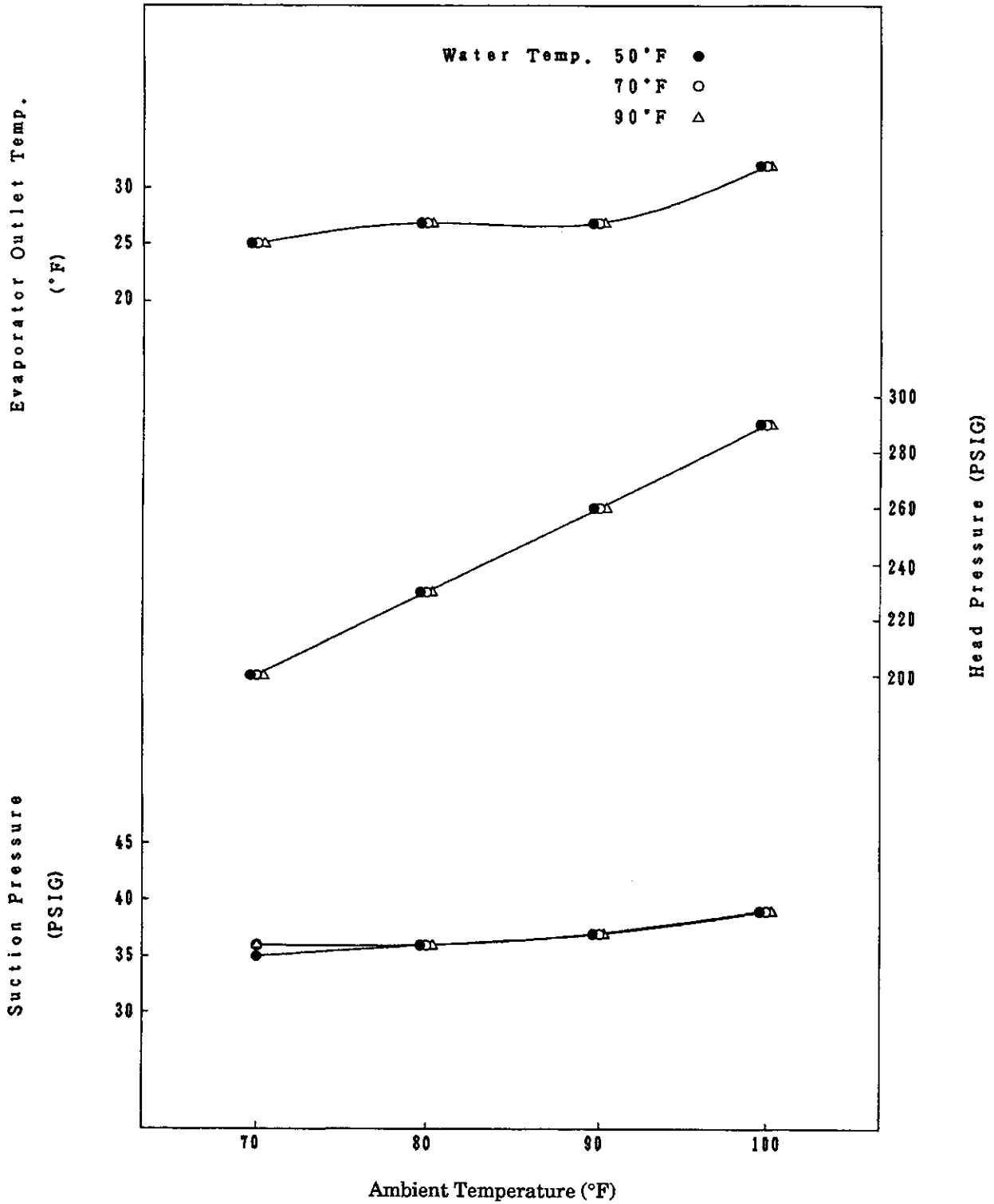

Fig. 26 Performance Data (2) - F-1100MAA

[b] F-1100MWA

APPROXIMATE ICE PRODUCTION PER 24 HR.	Ambient Temp. (°F)	Water Temp. (°F)		
		50	70	90
lbs./day (kg/day)	70	*1145 (519)	1030 (467)	875 (397)
	80	1130 (513)	1020 (463)	865 (392)
	90	1120 (508)	*1010 (458)	850 (386)
	100	1110 (503)	1000 (454)	840 (381)
APPROXIMATE ELECTRIC CONSUMPTION	70	*1240	1250	1260
	80	1250	1250	1260
	90	1250	*1250	1260
	100	1250	1250	1250
APPROXIMATE WATER CONSUMPTION PER 24 HR.	70	779 (2.95)	1111 (4.21)	1814 (6.87)
	80	788 (2.98)	1115 (4.22)	1850 (7.00)
	90	794 (3.01)	1130 (4.28)	1888 (7.15)
	100	809 (3.06)	1153 (4.36)	1929 (7.30)
EVAPORATOR OUTLET TEMP.	70	18(-8)	21(-6)	25(-4)
	80	19(-7)	21(-6)	27(-3)
	90	19(-7)	21(-5)	27(-3)
	100	19(-7)	21(-5)	27(-3)
HEAD PRESSURE	70	220 (15.4)	225 (15.8)	243 (17.0)
	80	220 (15.4)	225 (15.8)	243 (17.0)
	90	220 (15.4)	225 (15.8)	243 (17.0)
	100	220 (15.4)	225 (15.8)	243 (17.0)
PSIG (kg/cm ² G)	70	36 (2.5)	36 (2.5)	36 (2.5)
	80	36 (2.5)	36 (2.5)	36 (2.5)
	90	36 (2.5)	36 (2.5)	36 (2.5)
	100	36 (2.5)	36 (2.5)	36 (2.5)
SUCTION PRESSURE	70	36 (2.5)	36 (2.5)	36 (2.5)
	80	36 (2.5)	36 (2.5)	36 (2.5)
	90	36 (2.5)	36 (2.5)	36 (2.5)
	100	36 (2.5)	36 (2.5)	36 (2.5)
PSIG (kg/cm ² G)				
WATER FLOW FOR CONDENSER	76 gal/h (AT 100 °F/ WT 90 °F)			
PRESSURE DROP OF COOLING WATER LINE	Less than 7 PSIG			
HEAT OF REJECTION FROM CONDENSER	8380 BTU/h (AT 90 °F/ WT 70 °F)			
HEAT OR REJECTION FROM COMPRESSOR	1260 BTU/h (AT 90 °F/ WT 70 °F)			

Note: The data without *marks should be used for reference.

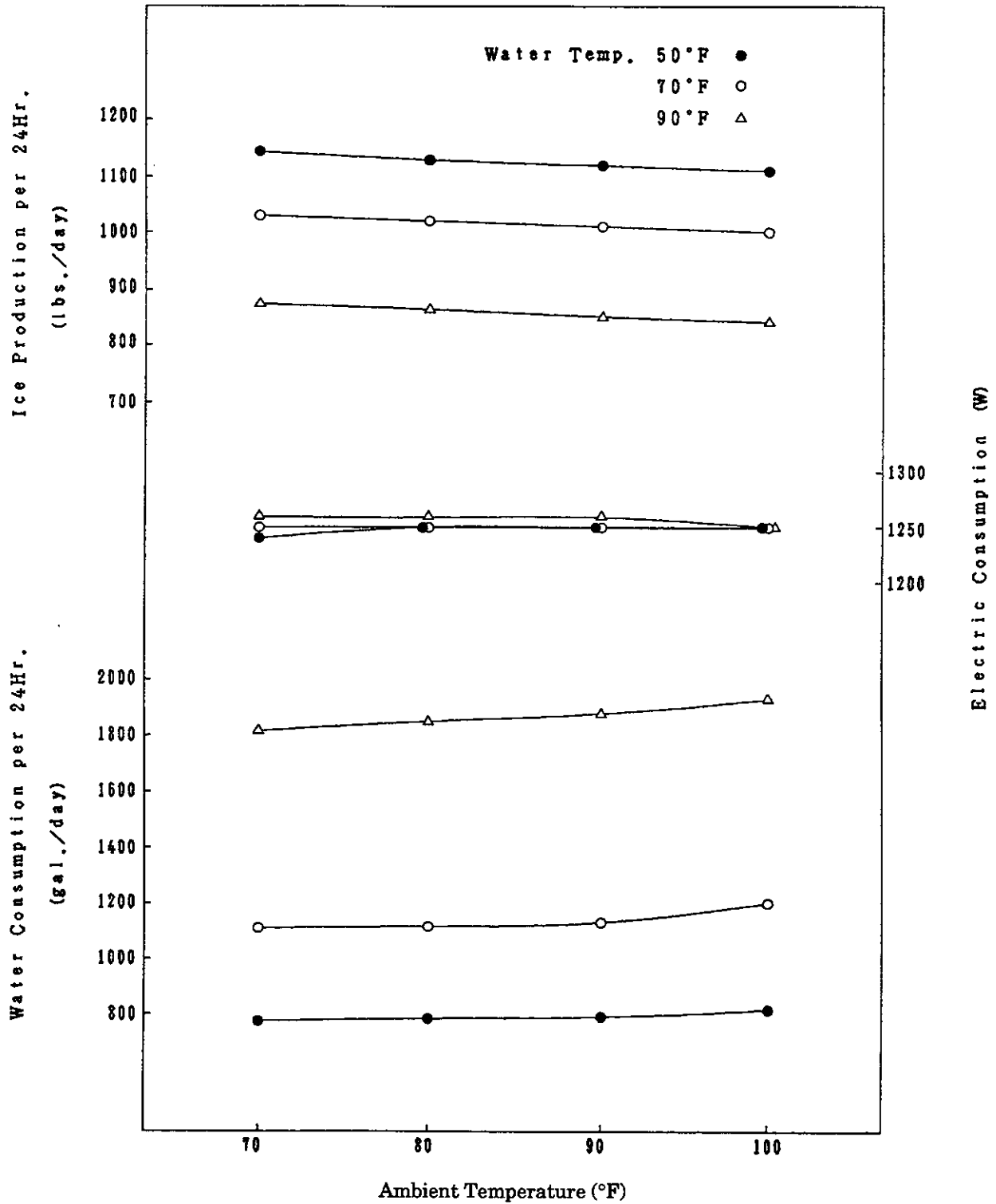

Fig. 27 Performance Data (1) - F-1100MWA

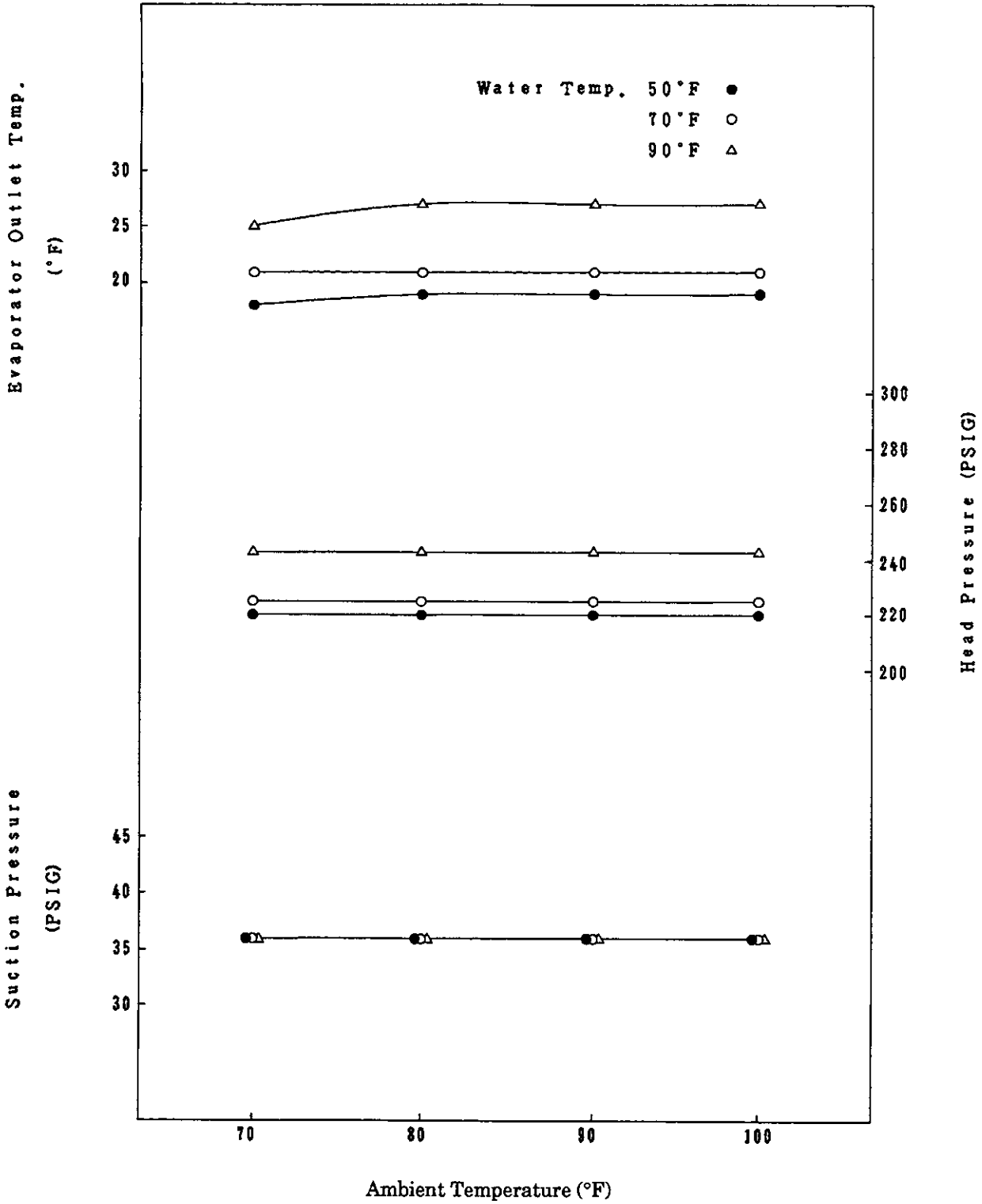

Fig. 28 Performance Data (2) - F-1100MWA

[c] F-1100MRA

APPROXIMATE ICE PRODUCTION PER 24 HR.	Ambient Temp. (°F)	Water Temp. (°F)		
		50	70	90
lbs./day (kg/day)	70	*1105 (501)	1005 (456)	920 (417)
	80	1015 (460)	930 (422)	865 (392)
	90	920 (417)	* 855 (388)	795 (361)
	100	815 (370)	750 (340)	705 (320)
APPROXIMATE ELECTRIC CONSUMPTION	70	*1350	1370	1370
	80	1380	1390	1390
	90	1400	*1400	1410
	100	1420	1420	1420
APPROXIMATE WATER CONSUMPTION PER 24 HR.	70	132 (501)	120 (456)	110 (417)
	80	122 (460)	111 (422)	104 (392)
	90	110 (417)	102 (388)	95 (361)
	100	98 (370)	90 (340)	84 (320)
EVAPORATOR OUTLET TEMP.	70	23 (-5)	23 (-5)	23 (-5)
	80	25 (-4)	25 (-4)	25 (-4)
	90	27 (-3)	27 (-3)	27 (-3)
	100	30 (-1)	30 (-1)	30 (-1)
HEAD PRESSURE	70	195 (13.7)	195 (13.7)	195 (13.7)
	80	220 (15.4)	220 (15.4)	220 (15.4)
	90	245 (17.2)	245 (17.2)	245 (17.2)
	100	270 (18.9)	270 (18.9)	270 (18.9)
SUCTION PRESSURE	70	36 (2.5)	37 (2.6)	37 (2.6)
	80	38 (2.5)	39 (2.7)	39 (2.7)
	90	41 (2.9)	41 (2.9)	41 (2.9)
	100	43 (3.0)	43 (3.0)	43 (3.0)
HEAT OF REJECTION FROM CONDENSER	9040 BTU/h (AT 90 ° F/WT 70 ° F)			
HEAT OR REJECTION FROM COMPRESSOR	1260 BTU/h (AT 90 ° F/WT 70 ° F)			
CONDENSER VOLUME	93 cu in			

Note: The data without *marks should be used for reference.

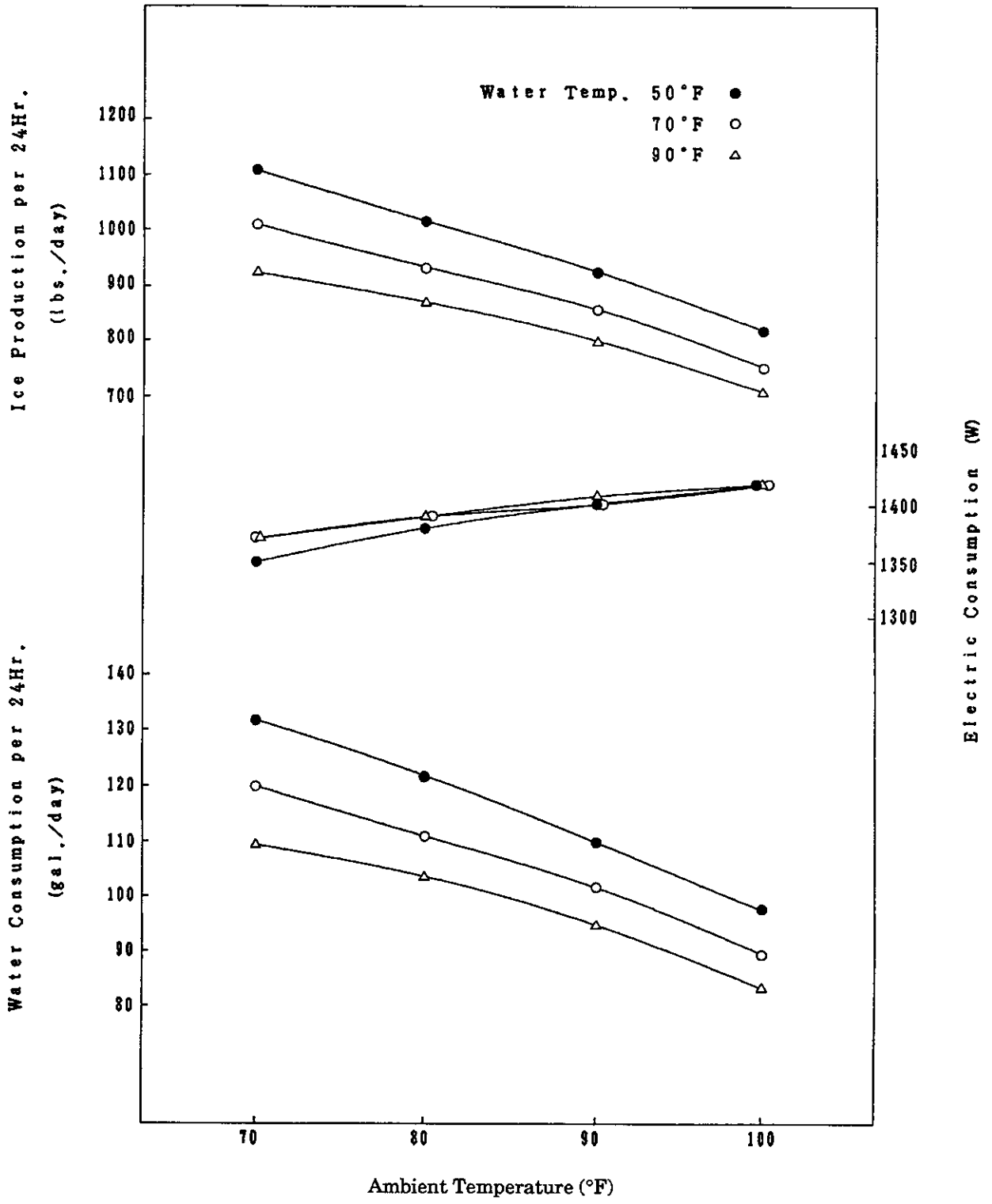

Fig. 29 Performance Data (1) - F-1100MRA

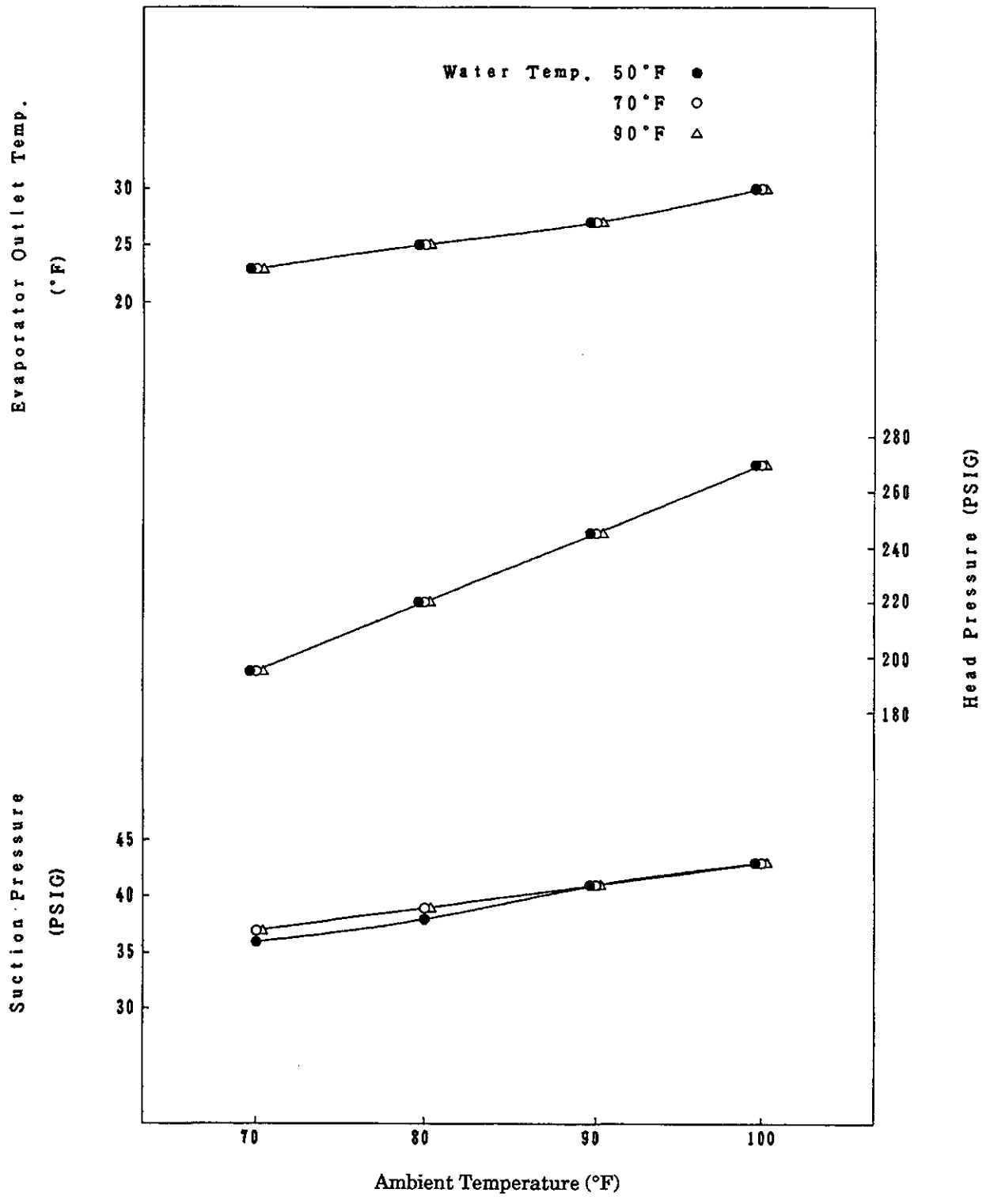

Fig. 30 Performance Data (2) - F-1100MRA

VI. SERVICE DIAGNOSIS

1. NO ICE PRODUCTION

PROBLEM	POSSIBLE CAUSE	REMEDY	
[1] The icemaker will not start.	a) Power Source	1. OFF position.	1. Move to ON position.
		2. Loose connections.	2. Tighten.
		3. Bad contacts.	3. Check for continuity and replace.
		4. Blown fuse.	4. Replace.
	b) Power Switch (Control Box)	1. OFF position.	1. Move to ON position.
		2. Bad contacts.	2. Check for continuity and replace.
c) Fuse (Control Box)	1. Blown.	1. Check for short-circuit and replace.	
d) Transformer	1. Coil winding opened.	1. Replace.	
e) Water Valve	1. Coil winding opened.	1. Replace.	
f) Shut-off Valve	1. Closed.	1. Open.	
	2. Water failure.	2. Wait till water is supplied.	
[2] Water does not stop, and the icemaker will not start.	a) Water Control Relay	1. Contacts fused.	1. Replace.
		2. Coil winding opened.	2. Replace.
	b) Float Switch	1. Bad contacts.	1. Check for continuity and replace.
2. Float does not move freely.		2. Clean or replace.	
c) Hoses	1. Disconnected.	1. Connect.	
[3] Water has been supplied, but the icemaker will not start.	a) Water Control Relay	1. Bad contacts.	1. Check for continuity and replace.
	b) Bin Control	1. Bad contacts.	1. Check for continuity and replace.
		2. Activator does not move freely.	2. Clean Axle and its corresponding holes or replace Bin Control.
	c) Bin Control Thermostat	1. Tripped with bin filled with ice.	1. Remove ice.
		2. Ambient temperature too cool.	2. Get warmer.
		3. Set too warm.	3. See "III. 9. FINAL CHECK LIST 9)."
		4. Bulb out of position.	4. Place in position.
		5. Bad contacts or leaks from bulb.	5. Check for continuity and replace.
	d) Protect Relay	1. Coil winding opened.	1. Replace.
		2. Bad contacts.	2. Check for continuity and replace.
e) Gear Motor Relay	1. Coil winding opened.	1. Replace.	
	2. Bad contacts.	2. Check for continuity and replace.	
f) Circuit Breaker	1. Tripped.	1. Find out the cause, get rid of it, and press Reset Button on Circuit Breaker.	

	g) Timer	1. Broken.	1. Replace.
	h) Pig Tail Leads	1. White lead not connected to neutral line.	1. Connect correctly.
[4] Gear Motor starts, but Compressor will not start or operates intermittently.	a) Pressure Switch	1. Dirty Air Filter or Condenser.	1. Clean.
		2. Ambient or condenser water temperature too warm.	2. Get cooler.
		3. Refrigerant overcharged.	3. Recharge.
		4. Condenser water pressure too low or off.	4. Check and get recommended pressure.
		5. Fan not rotating.	5. See "3. [1] a) Fan Motor."
		6. Refrigerant line or components plugged.	6. Clean and replace drier.
		7. Bad contacts.	7. Check for continuity and replace.
		8. Loose connections.	8. Tighten.
	b) X2 Relay on Timer	1. Bad contacts.	1. Check for continuity and replace Timer.
		2. Coil winding opened.	2. Replace Timer.
	c) Starter	1. Bad contacts.	1. Check for continuity and replace.
		2. Coil winding opened.	2. Replace.
		3. Loose connections.	3. Tighten.
	d) Start Capacitor or Run Capacitor	1. Defective.	1. Replace.
e) Compressor	1. Loose connections.	1. Tighten.	
	2. Motor winding opened or grounded.	2. Replace.	
	3. Motor Protector (Internal) tripped.	3. Find out the cause of overheat.	
f) Fan Motor	1. Fan not rotating.	1. See "3. [1] a) Fan Motor."	
g) Power Supply	1. Circuit Ampacity too low	1. Install a larger-sized conductor.	
[5] Gear Motor and Compressor start, but no ice is produced.	a) Refrigerant Line	1. Gas leaks	1. Check for leaks with a leak detector. Reweld leak, replace drier and charge with refrigerant. The amount of refrigerant is marked on Nameplate or Label.
		2. Refrigerant line clogged	2. Replace the clogged component.

2. LOW ICE PRODUCTION

PROBLEM	POSSIBLE CAUSE	REMEDY	
[1] Low ice production	a) Refrigerant Line	1. Gas leaks	1. See "1. [5] a) Refrigerant Line."
		2. Refrigerant line clogged	2. Replace the clogged component.
		3. Overcharged	3. Recharge.
	b) High-side Pressure Too High	1. Dirty Air Filter or Condenser	1. Clean.
		2. Ambient or condenser water temperature too warm.	2. Get cooler.
		3. Condenser water pressure too low or off.	3. Check and get recommended pressure.
		4. Fan rotating too slow.	4. See "3. [1] a) Fan Motor."
		5. Water Regulator clogged.	5. Clean.
	c) Expansion Valve (not adjustable)	1. Low-side pressure exceeding the limit	1. Replace.

3. OTHERS

PROBLEM	POSSIBLE CAUSE	REMEDY	
[1] Abnormal noise	a) Fan Motor	1. Bearings worn out.	1. Replace.
		2. Fan blade deformed.	2. Replace fan blade.
		3. Fan blade does not move freely.	3. Replace.
	b) Compressor	1. Bearings worn out, or cylinder valve broken.	1. Replace.
		2. Mounting pad out of position.	2. Reinstall.
	c) Refrigerant Lines	1. Rub or touch lines or other surfaces.	1. Replace.
	d) Gear Motor (Ice Making)	1. Bearing or Gear wear/damage	1. Replace.
	e) Evaporator	1. Low-side pressure too low.	1. See if Expansion Valve bulb is mounted properly, and replace the valve if necessary.
		2. Scale on inside wall of Freezing Cylinder.	2. Remove Auger. Use "LIME-A-WAY" solution to clean periodically. If water is found to be hard by testing, install a softener.
	[2] Overflow from Reservoir	a) Water Supply	1. Water pressure too high.

(Water does not stop.)	b) Water Valve	1. Diaphragm does not close.	1. Clean or replace.
	c) Float Switch	1. Bad contacts.	1. Check for continuity and replace.
[3] Gear Motor Protector operates frequently.	a) Power Supply Voltage	1. Too high or too low.	1. Connect the unit to a power supply of proper voltage.
	b) Evaporator Assy	1. Bearings or Auger worn out.	1. Replace Bearing or Auger.

VII. REMOVAL AND REPLACEMENT OF COMPONENTS

1. SERVICE FOR REFRIGERANT LINES

[a] REFRIGERANT DISCHARGE

A Refrigerant Access Valve on the LOW-SIDE line is provided with the icemaker unit. Install a proper fitting on the HIGH-SIDE line, if necessary, to check the gauge pressure.

[b] EVACUATION AND RECHARGE

- 1) Attach Charging Hoses, a Service Manifold and a Vacuum Pump to the system.
- 2) Turn on the Vacuum Pump.
- 3) Allow the Vacuum Pump to pull down to a 29.9" Hg vacuum. Evacuating period depends on pump capacity.
- 4) Close the Low-side Valve on the Service Manifold.
- 5) Disconnect the Vacuum Pump, and attach a Refrigerant Service Cylinder. Remember to loosen the connection, and purge the air from the Hose. See NAMEPLATE for refrigerant charge.
- 6) Open the Low-side Valve. Do not invert the Service Cylinder. A LIQUID CHARGE will damage the Compressor.
- 7) Turn on the icemaker when charging speed gets slow. Turn off the icemaker when the Low-side Gauge shows approximately 0 PSIG. DO NOT run the icemaker at negative pressures. Close the Low-side Valve when the Service Cylinder gets empty.
- 8) Repeat the above steps 4) through 7), if necessary, until a required amount of refrigerant has entered the system.
- 9) Close the Refrigerant Access Valve, and disconnect the Hoses, Service Manifold, and so on.
- 10) Cap the Access Valve to prevent possible leak.

2. BRAZING

DANGER

1. Refrigerant R502 itself is not flammable, explosive and poisonous. However, when exposed to an open flame, R502 creates Phosgene gas, hazardous in large amounts.
2. Always purge the refrigeration system through hose vented to the outside, because it is dangerous for the room to be filled with R502 and short of oxygen.
3. Do not use silver alloy or copper alloy containing Arsenic.
4. In its liquid state, the refrigerant can cause frostbite because of the low temperature.

3. REMOVAL AND REPLACEMENT OF COMPRESSOR

IMPORTANT

Always install a new Drier every time the sealed refrigeration system is opened. Do not replace the Drier until after all other repairs or replacement have been made.

- 1) Turn off the power supply.
- 2) Remove the panels.
- 3) Remove the Terminal Cover on the Compressor, and disconnect the Compressor Wiring.
- 4) Discharge the refrigerant.
- 5) Unsolder and disconnect the Discharge and Suction Pipes and the Oil Cooler Tube from the Compressor.

WARNING

When repairing a refrigerant system, be careful not to let the burner flame contact the lead wires or insulation.

- 6) Remove the Hold-down Bolts, Washers and Rubber Grommets.
- 7) Slide and remove the Compressor. Unpack a new Compressor package. Install a new Compressor.
- 8) Attach the Rubber Grommets of the prior Compressor.
- 9) Sandpaper the Suction, Discharge and Process Pipes.
- 10) Place the Compressor in position, and secure it using the Bolts and Washers.
- 11) Remove plugs from the Suction, Discharge and Process Pipes.
- 12) Braze the Process, Suction and Discharge Pipes (DO NOT change this order), with nitrogen gas flowing at the pressure of 3 - 4 PSIG.

WARNING

Always PROTECT the Access Valve using a DAMP CLOTH to prevent
overheat. DO NOT braze with the Access Valve exceeding 250°F.

- 13) Install a new Drier.
- 14) Check for leaks using nitrogen gas (140 PSIG) and soap bubble.
- 15) Connect the Compressor Wiring to the Compressor, and replace the Terminal Cover.
- 16) Evacuate the system, and charge it with refrigerant. See NAMEPLATE for required refrigerant charge. (For the Remote Air-cooled model, see the label on the Control Box.)
- 17) Replace the panels.
- 18) Turn on the power supply.

4. REMOVAL AND REPLACEMENT OF DRIER

IMPORTANT

Do not replace the Drier until after all other repairs or replacement have been made.

- 1) Turn off the power supply.
- 2) Remove the panels.
- 3) Remove the Clamp securing the Drier.
- 3) Discharge the refrigerant.
- 4) Install a new Drier with the arrow on the Drier in the direction of the refrigerant flow. Use nitrogen gas at the pressure of 3 - 4 PSIG when brazing the tubings.
- 5) Check for leaks using nitrogen gas (140 PSIG) and soap bubble.
- 6) Evacuate the system, and charge it with refrigerant. See NAMEPLATE for required refrigerant charge. (For the Remote Air-cooled model, see the label on the Control Box.)
- 7) Secure the Drier with the Clamp.
- 8) Replace the panels.
- 9) Turn on the power supply.

5. REMOVAL AND REPLACEMENT OF EXPANSION VALVE

- 1) Turn off the power supply.
- 2) Remove the Front Panel.
- 3) Discharge the refrigerant.
- 4) Remove the Expansion Valve Covers and the Expansion Valve Bulb, and disconnect the Expansion Valve using a brazing equipment.
- 5) Braze the new Expansion Valve with nitrogen gas flowing at the pressure of 3 - 4 PSIG.

WARNING

Always PROTECT the Expansion Valve using a DAMP CLOTH to prevent the Expansion Valve from overheat. DO NOT braze with the Expansion Valve exceeding 250°F.

- 6) Install a new Drier.
- 7) Check for leaks using nitrogen gas (140 PSIG) and soap bubble.
- 8) Evacuate the system, and charge it with refrigerant. See NAMEPLATE for required refrigerant charge. (For the Remote Air-cooled model, see the label on the Control Box.)
- 9) Attach the Bulb to the suction line. Be sure to secure the Bulb using a band and to insulate it.
- 10) Place a new set of Expansion Valve Covers in position.
- 11) Replace the panels.
- 12) Turn on the power supply.

6. REMOVAL AND REPLACEMENT OF WATER REGULATING VALVE - WATER-COOLED MODEL ONLY

IMPORTANT

Always install a new Drier every time the sealed refrigeration system is opened. Do not replace the Drier until after all other repairs or replacement have been made.

- 1) Turn off the power supply.
- 2) Close the Water Supply Line Shut-off Valve.
- 3) Remove the panels.
- 4) Discharge the refrigerant.
- 5) Disconnect the Capillary Tube using a brazing equipment.
- 6) Disconnect the Flare-connections of the valve.
- 7) Remove the screws and the valve from the Bracket.
- 8) Install a new valve, and braze the Capillary Tube.
- 9) Install a new Drier.
- 10) Check for leaks using nitrogen gas (140 PSIG) and soap bubble.
- 11) Connect the Flare-connections.
- 12) Open the Water Supply Line Shut-off Valve.
- 13) Turn on the power supply.
- 14) Check for water leaks.
- 15) Evacuate the system, and charge it with refrigerant. See NAMEPLATE for required refrigerant charge. (For the Remote Air-cooled model, see the label on the Control Box.)
- 16) See "VIII. 1. ADJUSTMENT OF WATER REGULATING VALVE." If necessary, adjust the valve.
- 17) Place the panels in position.

7. REMOVAL AND REPLACEMENT OF CONDENSING PRESSURE REGULATOR (C.P.R.) - REMOTE AIR-COOLED MODEL ONLY

IMPORTANT

Always install a new Drier every time the sealed refrigeration system is opened. Do not replace the Drier until after all other repairs or replacement have been made.

- 1) Turn off the power supply.
- 2) Remove the panels from the remote condenser unit.
- 3) Discharge the refrigerant. See "1. [a] REFRIGERANT DISCHARGE."
- 4) Remove the C.P.R. using a brazing equipment.
- 5) Install a new C.P.R. Always PROTECT the valve body using a DAMP CLOTH to prevent overheat. DO NOT braze with the valve body exceeding 250°F. Use nitrogen gas at the pressure of 3 - 4 PSIG when brazing the C.P.R..
- 6) Install a new Drier in the icemaker.
- 7) Check for leaks using nitrogen gas (140 PSIG) and soap bubble.
- 8) Evacuate the system and charge it with refrigerant. See the Label on the Control Box in the icemaker.
- 9) Place the panels in position.
- 10) Turn on the power supply.

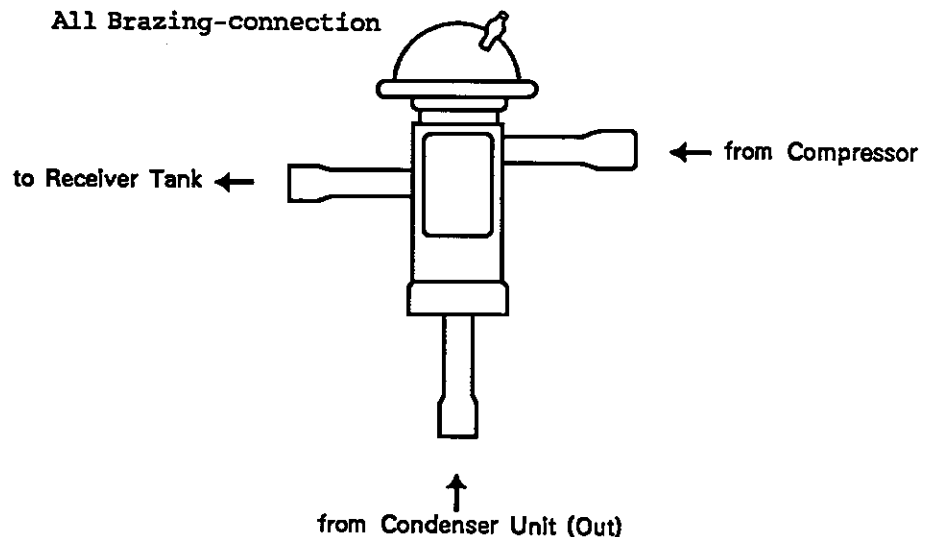

Fig. 31

8. REMOVAL AND REPLACEMENT OF COMPONENTS OF EVAPORATOR ASSEMBLY - See Fig. 32

- 1) Turn off the power supply.
- 2) Remove the panels.
- 3) Remove the Drain Cap and drain the water in the Evaporator.
- 4) Remove the Thumbscrew and the Chute Cover Assembly.
- 5) Remove the three Thumbscrews and take off the Chute Head from the Evaporator.

CUTTER

- 6) Remove the Bolt and lift off the Cutter.
- 7) Remove the Rubber O-ring and the Nylon O-ring at the top of the Evaporator.

EXTRUDING HEAD

- 8) Remove the three Socket Head Cap Screws and lift off the Extruding Head.
- 9) Replace the Bearing inside the Extruding Head, if it is worn or scratched.

Note: Replacing the Bearing needs a fitting tool. If it is not available, replace the whole Extruding Head.

AUGER

- 10) Lift off the Auger. If the Bearing is worn or the Blade scratched, replace the Auger.

EVAPORATOR

Note: Skip the following steps 11) through 13) when the Evaporator does not need replacement.

- 11) Discharge the refrigerant.

IMPORTANT

Always install a new Drier every time the sealed refrigeration system is opened. Do not replace the Drier until after all other repairs or replacement have been made.

- 12) Remove the Bulb of the Expansion Valve.
- 13) Disconnect the brazing-connections of the Expansion Valve and the Copper Tube - Low Side from the Evaporator, using a brazing equipment.
- 14) Remove the two Truss Head Machine Screws and the Strap securing the Evaporator.
- 15) Disconnect the three Hoses from the Evaporator.
- 16) Remove the four Hexagon Socket Cap Bolts securing the Evaporator with the Bearing-Lower.
- 17) Lift off the Evaporator.

BEARING-LOWER AND MECHANICAL SEAL

- 18) The Mechanical Seal consists of two parts. One moves along with the Auger, and the other is fixed on the Bearing-Lower. If the contact surfaces of these two parts is worn or scratched, the Mechanical Seal may cause water leaks and should be replaced.
- 19) Remove the O-ring on the Bearing-Lower.
- 20) Remove the six Bolts and the Bearing-Lower from the Gear Motor. Replace the Bearing inside the Bearing-Lower using a fitting tool, if it is worn or scratched.

GEAR MOTOR

- 21) Remove the Barrier on the top of the Gear Motor.
- 22) Open the Terminal Cover of the Gear Motor and cut the Connectors.
- 23) Remove the three Hexagon Socket Cap Bolts securing the Gear Motor.

24) Assemble the removed parts in the reverse order of the above procedure.

WARNING

Be careful not to scratch the surface of the O-ring, or it may cause water leaks. Handle the Mechanical Seal with care not to scratch nor to contaminate its contact surface.

25) When replacing the Evaporator;

- (a) Braze the new Evaporator with nitrogen gas flowing at the pressure of 3 - 4 PSIG.
- (b) Replace the Drier.
- (c) Check for leaks using nitrogen gas (140 PSIG) and soap bubble.
- (d) Evacuate the system, and charge it with refrigerant. See NAMEPLATE for required refrigerant charge. (For the Remote Air-cooled model, see the label on the Control Box.)

26) Turn on the power supply.

27) Place the panels in position.

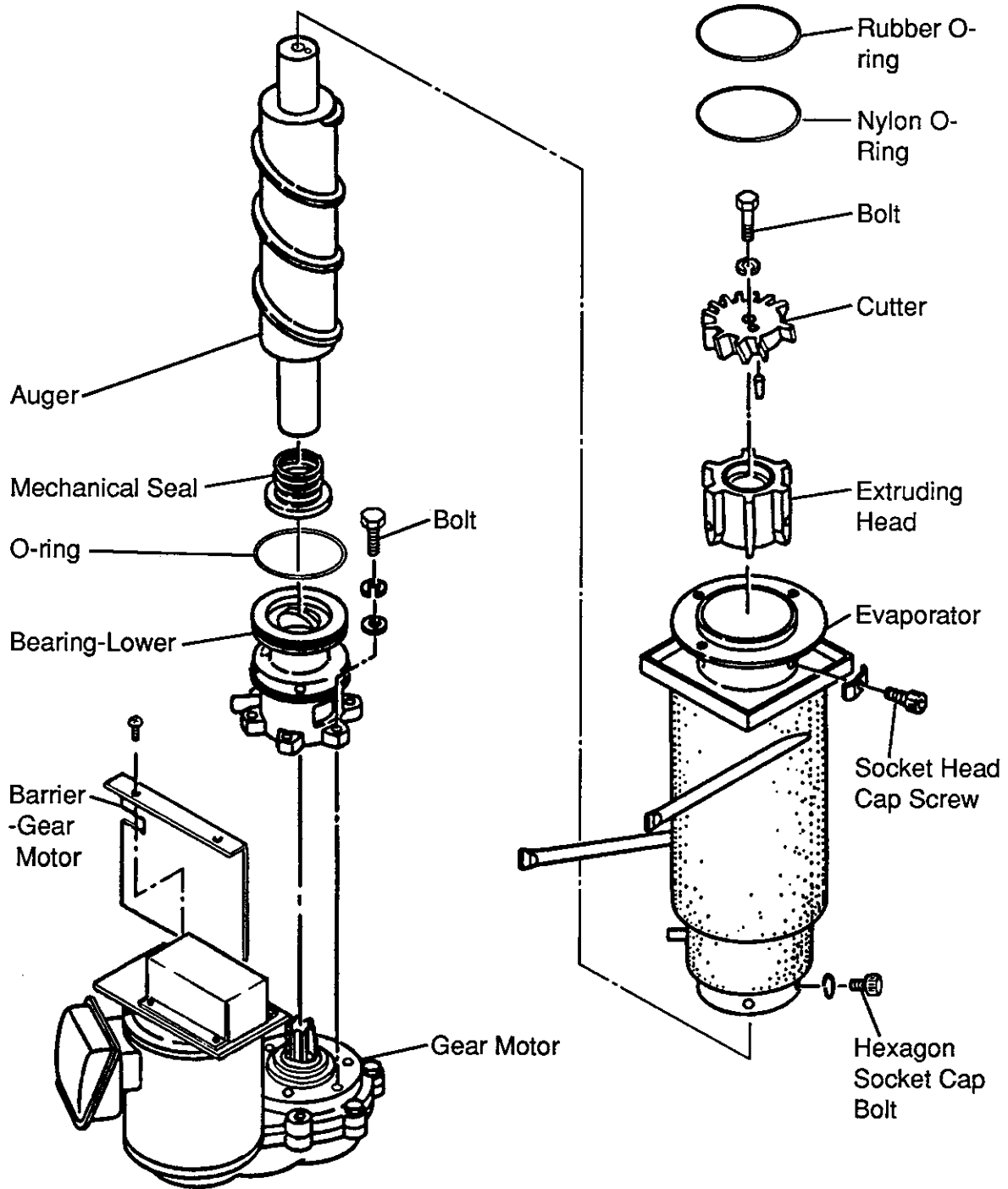

Fig. 32

9. REMOVAL AND REPLACEMENT OF FAN MOTOR

- 1) Turn off the power supply.
- 2) Remove the panels.
- 3) Remove the wire connectors from the Fan Motor leads.
- 4) Remove the Fan Motor Bracket and Fan Motor.
- 5) Install a new Fan Motor.
- 6) Replace the Fan Motor Bracket and the wire connectors.
- 7) Place the panels in position.
- 8) Turn on the power supply.

10. REMOVAL AND REPLACEMENT OF WATER VALVE

- 1) Turn off the power supply.
- 2) Close the Water Supply Line Shut-off Valve.
- 3) Remove the panels.
- 4) Disconnect the terminals from the Water Valve.
- 5) Remove the Cover-Reservoir Inlet from the Water Valve.
- 6) Loosen the Fitting Nuts on the Water Valve Inlets, and remove the Water Valve. Do not lose the Packings inside the Fitting Nuts.
- 7) Install a new Water Valve.
- 8) Assemble the removed parts in the reverse order of the above procedure.
- 9) Open the Water Supply Line Shut-off Valve.
- 10) Turn on the power supply.
- 11) Check for water leaks.
- 12) Place the panels in position.

VIII. ADJUSTMENT OF COMPONENTS

1. ADJUSTMENT OF WATER REGULATING VALVE

The Water Regulating Valve or also called "WATER REGULATOR" is factory-adjusted. No adjustment is required under normal use. Adjust the Water Regulator, if necessary, using the following procedures.

- 1) Attach a pressure gauge to the high-side line of the system. Or prepare a thermometer to check the condenser drain temperature.
- 2) Rotate the adjustment screw by using a flat blade screwdriver, so that the pressure gauge shows 230 PSIG, or the thermometer reads 100 - 104°F, in 5 minutes after the icemaking process starts. When the pressure exceeds 230 PSIG, or the condenser drain temperature exceeds 104°F, rotate the adjustment screw counterclockwise.
- 3) Check that the pressure or the condenser drain temperature holds a stable setting.

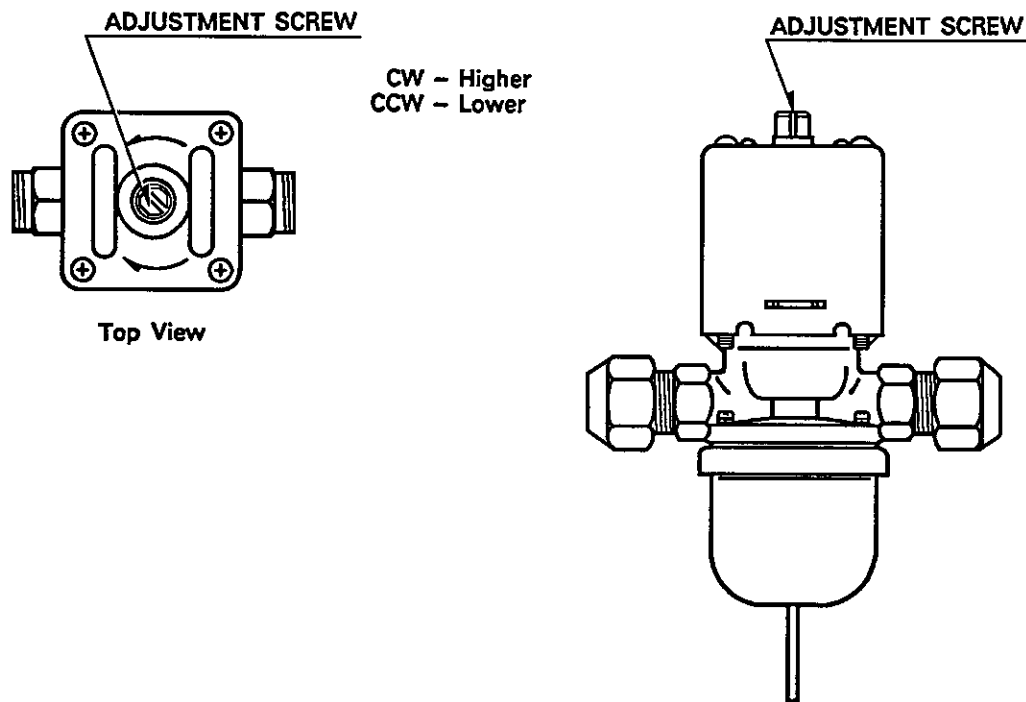

Fig. 33

2. ADJUSTMENT OF CUTTER

To adjust the ice size, change the direction of the Cutter on the top of the Auger, according to the following procedure.

- 1) Remove the Bolt and the Cutter.
- 2) The Cutter is marked with "L", "M" and "S" and adjusted in "M" before shipping. Adjust it in "L" or "S", if necessary.

SETTING	TYPE OF ICE
Large	Coarse
Medium	Flake
Small	Fine



Fig. 34

- 3) Place the Cutter so that the pin on the top of the Auger fits into the hole next to the marking "L", "M" or "S".
- 4) Secure the Cutter by the Bolt.



HOSHIZAKI
HOSHIZAKI ELECTRIC CO., LTD.

TOYOAKE, AICHI, JAPAN
PHONE: 0562-97-2111
TELEX-NO: 04486-514 HOSHI J