



HOSHIZAKI

MODULAR FLAKER

MODEL
F-1100MRA

FINAL

PARTS LIST

ISSUED: MAY 28, 1990

REVISED: NOV. 16, 1993

PRINTED: DEC. 30, 1994

ITEM NO: 71035

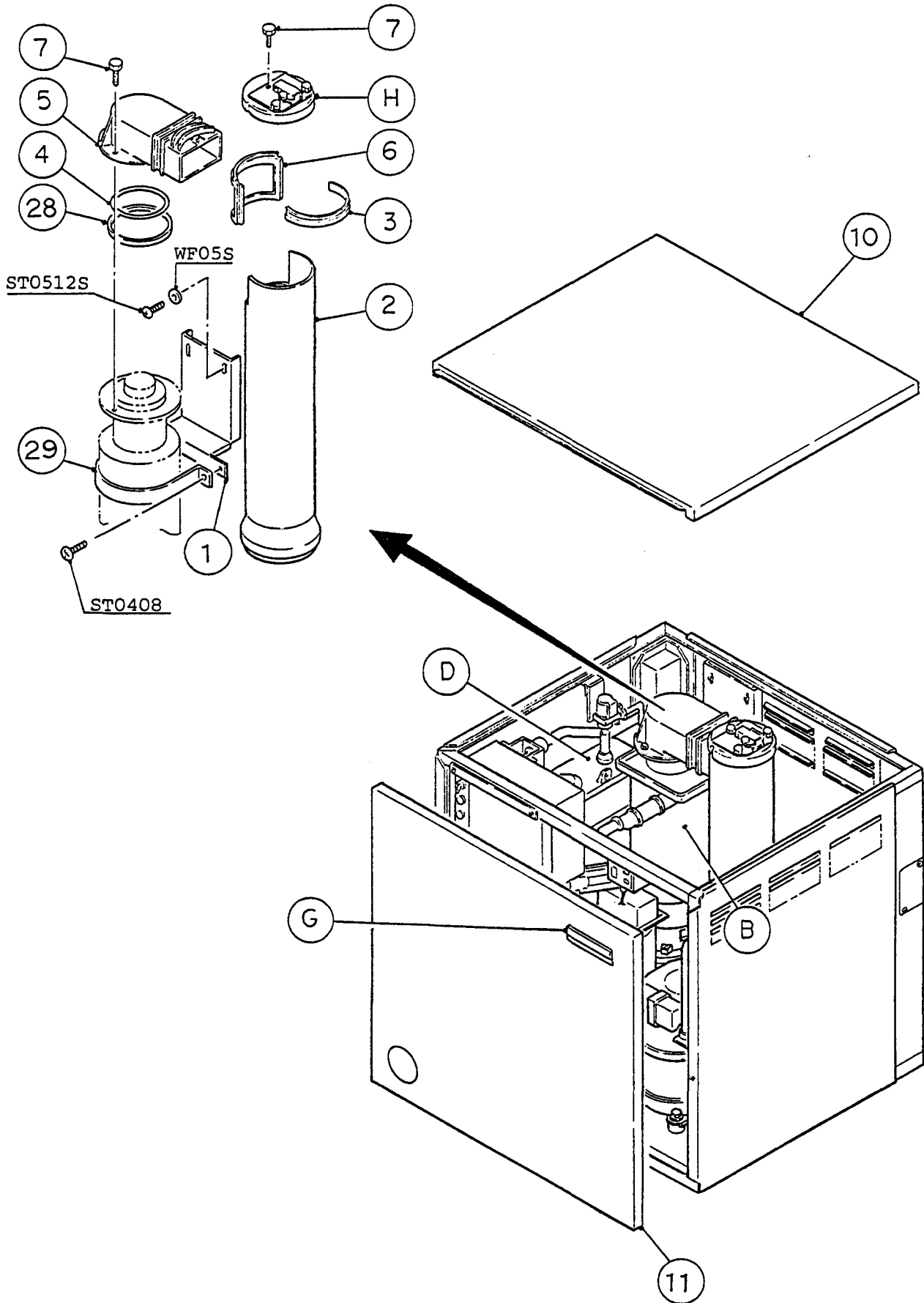

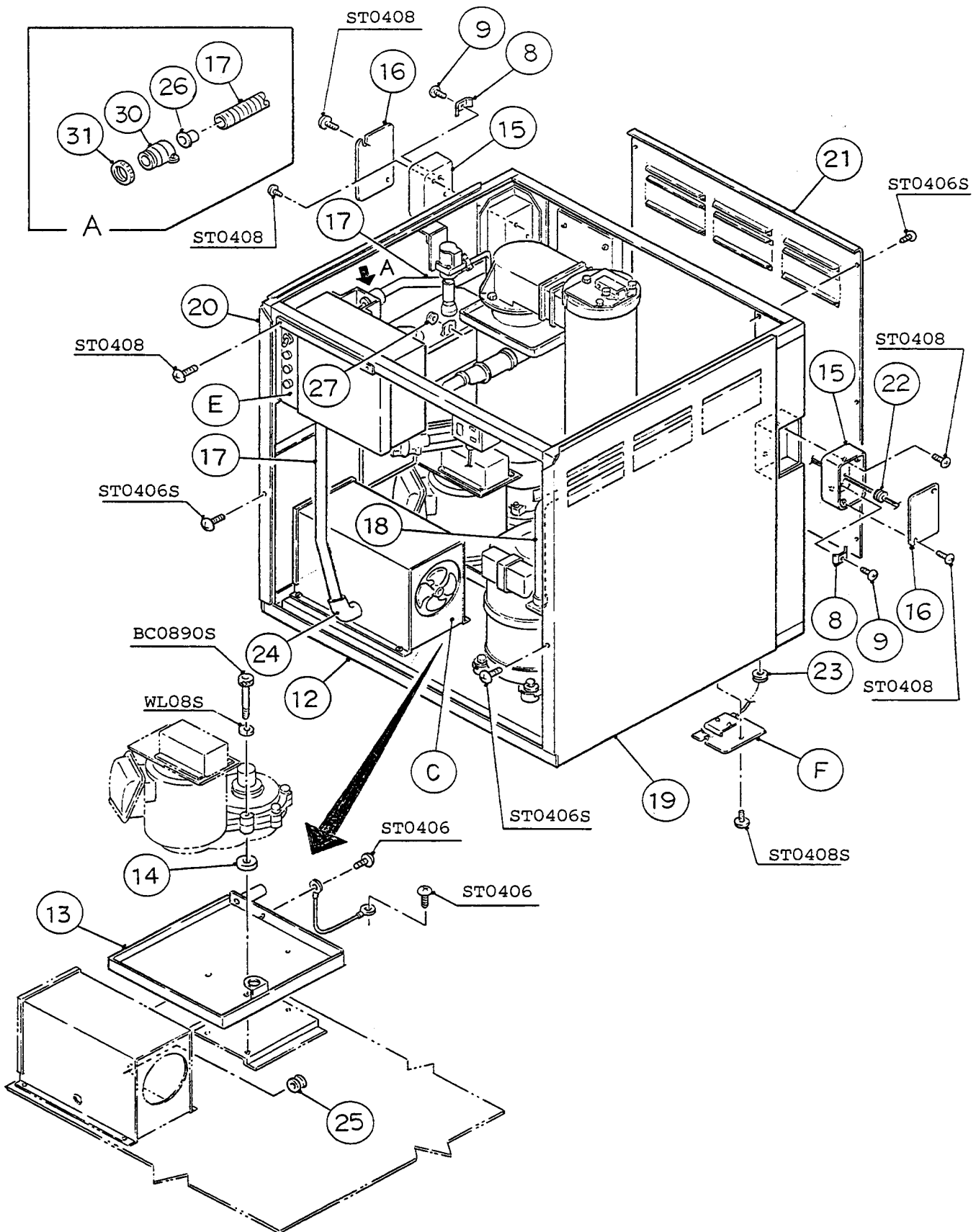

MODEL F-1100MRA		TITLE A. ICE FLAKER ASSY						
INDEX NO.	DESCRIPTION	MATERIAL OR MODEL NUMBER	PART NUMBER	REQ'D NUMBER				
				K-1	A-0	B-0	B-1	C-0
B	EVAPORATOR ASSY	-	319958A03	1	1	1	1	1
C	REFRIGERATION UNIT	-	104901A01	1	1	1	1	1
D	WATER CIRCUIT ASSY	-	103078A04	1	1	1	1	1
E	CONTROL BOX ASSY	-	214652A03	1	1	1	1	1
F	BIN SWITCH ASSY	-	317649A01	1	1	1	1	1
G	LABEL LOCATION	-	213149A06	1	1	1	1	1
H	SPOUT CONTROL ASSY	-	325071A01	1	1	1	1	1
1	Bracket - Evaporator	G.S	431735-01	1	1	1	1	1
2	Chute	PE	315723-01	1	1	1	1	1
3	Packing - Chute	EPDM	425255-01	1	1	1	1	1
4	"O" Ring	G95	7616-G095	1	1	1	1	1
5	Spout	PC	103932G01	1	1	1	1	1
6	Packing - Spout	EPDM	315722-01	1	1	1	1	1
7	Thumbscrew	S.S, ABS	415949G03	4	4	4	4	4
8	Square Washer	Copper	433537-01	2	2	2	2	2
9	Screw - Grounding	Brass	433304-01	2	2	2	2	2
10	Top Panel	S.S	315750G01	1	1	1	1	-
			315750G02					1
11	Front Panel	S.S	315937-02	1	1	1	1	-
			315937-03					1
12	Frame	G.S	315778G11	1	1	1	1	1
13	Drip Pan	S.S	317168G01	1	1	1	1	1
14	Washer	PVC	422916-01	3	3	3	3	3
15	Junction Box	No.6001	421587-01	2	2	2	2	2
16	Cover - Junction Box	G.S	420594-01	2	2	2	2	2
17	Conduit	-	429313-02	2	2	2	2	2
18	Conduit	-	429313-03	1	1	1	1	2
19	Side Panel (Right)	S.S	315934G01	1	1	1	1	-
			315934G02					1
20	Side Panel (Left)	S.S	315935G02	1	1	1	1	-
			315935G03					1
21	Rear Panel	S.S	315936-02	1	1	1	1	1
22	Bushing	SR-4K-4	420472-01	1	1	1	1	1
23	Bushing	SB-437-5	420470-07	1	1	1	1	1
24	Fitting - Conduit, Elbow	No.13-16	425317-01	1	1	1	1	1
25	Bushing	SB-625-8	420470-01	1	1	1	1	1
26	Collar	Steel	430335-01	6	6	6	6	6
27	Bushing	SR-30-1	420472-03	1	1	1	1	1
28	Ring	PA	431736-01	1	1	1	1	1
29	Strap	G.S	431737-01	1	1	1	1	1
30	Fitting – Conduit	NS-1621	435753-01	5	5	5	5	5
31	Nut	t3.6	435753F01	5	5	5	5	5

MODEL		TITLE						
F-1100MRA		A. ICE FLAKER ASSY						
INDEX NO.	DESCRIPTION	MATERIAL OR MODEL NUMBER	PART NUMBER	REQ'D NUMBER				
				C-1				
B	EVAPORATOR ASSY	-	319958A03	1				
C	REFRIGERATION UNIT	-	104901A01	1				
D	WATER CIRCUIT ASSY	-	103078A04	1				
E	CONTROL BOX ASSY	-	214652A03	-				
			214652A06	1				
F	BIN SWITCH ASSY	-	317649A01	1				
G	LABEL LOCATION	-	213149A06	1				
H	SPOUT CONTROL ASSY	-	325071A01	1				
1	Bracket - Evaporator	G.S	431735-01	1				
2	Chute	PE	315723-01	1				
3	Packing - Chute	EPDM	425255-01	1				
4	"O" Ring	G95	7616-G095	1				
5	Spout	PC	103932G01	1				
6	Packing - Spout	EPDM	315722-01	1				
7	Thumbscrew	S.S, ABS	415949G03	4				
8	Square Washer	Copper	433537-01	2				
9	Screw - Grounding	Brass	433304-01	2				
10	Top Panel	S.S	315750G02	1				
11	Front Panel	S.S	315937-03	1				
12	Frame	G.S	315778G11	1				
13	Drip Pan	S.S	317168G01	1				
14	Washer	PVC	422916-01	3				
15	Junction Box	No.6001	421587-01	2				
16	Cover - Junction Box	G.S	420594-01	2				
17	Conduit	-	429313-02	2				
18	Conduit	-	429313-03	1				
19	Side Panel (Right)	S.S	315934G02	1				
20	Side Panel (Left)	S.S	315935G03	1				
21	Rear Panel	S.S	315936-02	1				
22	Bushing	SR-4K-4	420472-01	1				
23	Bushing	SB-437-5	420470-07	1				
24	Fitting – Conduit, Elbow	No.13-16	425317-01	1				
25	Bushing	SB-625-8	420470-01	1				
26	Collar	Steel	430335-01	6				
27	Bushing	SR-30-1	420472-03	1				
28	Ring	PA	431736-01	1				
29	Strap	G.S	431737-01	1				
30	Fitting – Conduit	NS-1621	435753-01	5				
31	Nut	t3.6	435753F01	5				

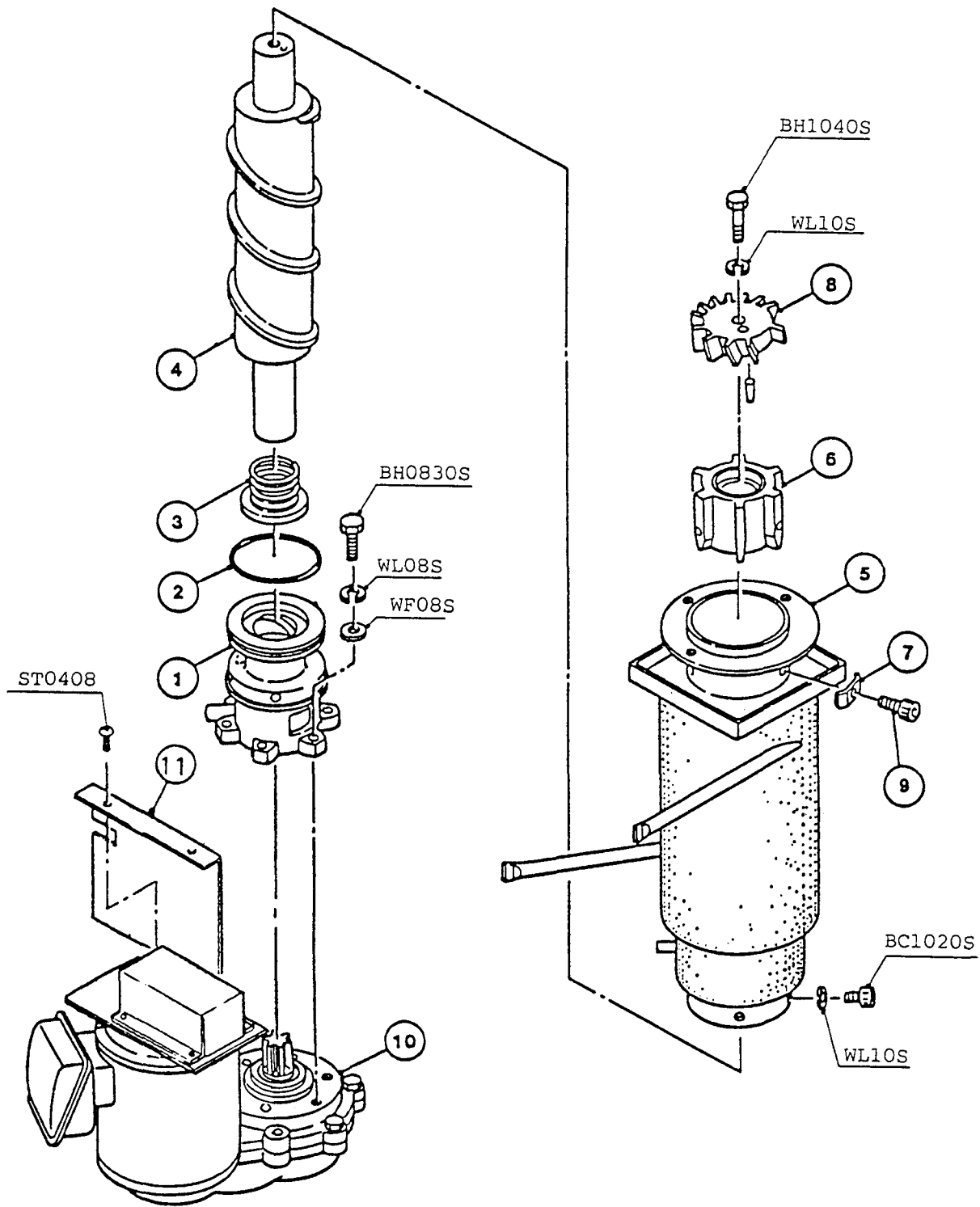

MODEL		TITLE						
F-1100MRA		B. EVAPORATOR ASSY						
INDEX NO.	DESCRIPTION	MATERIAL OR MODEL NUMBER	PART NUMBER	REQ'D NUMBER				
				K-1	A-0	B-0	B-1	C-0
1	Bearing (Lower)	-	315732G02	1	1	1	1	1
2	"O" Ring	G90	7616-G090	1	1	1	1	1
3	Mechanical Seal	HK9A-MN	432493-01	1	1	1	1	1
4	Auger	S.S	211062G01	1	1	1	1	1
5	Evaporator	-	425273G04	1	1	1	1	1
6	Extruding Head	S.S	208117G02	1	1	1	1	1
7	Washer	S.S	425277-01	3	3	3	3	3
8	Cutter	S.S	315734-01	1	1	1	1	1
9	Socket Head Cap Screw	S.S, M10	429121-02	3	3	3	3	3
10	Gear Motor	MGZ2200UL-160	432068-01	1	1	1	1	1
11	Cover - Gear Motor	G.S	431532-01	1	1	1	1	1

MODEL		TITLE						
F-1100MRA		B. EVAPORATOR ASSY						
INDEX NO.	DESCRIPTION	MATERIAL OR MODEL NUMBER	PART NUMBER	REQ'D NUMBER				
				C-1				
1	Bearing (Lower)	-	315732G02	1				
2	"O" Ring	G90	7616-G090	1				
3	Mechanical Seal	HK9A-MN	432493-01	1				
4	Auger	S.S	211062G01	1				
5	Evaporator	-	425273G04	1				
6	Extruding Head	S.S	208117G02	1				
7	Washer	S.S	425277-01	3				
8	Cutter	S.S	315734-01	1				
9	Socket Head Cap Screw	S.S, M10	429121-02	3				
10	Gear Motor	MGZ2200UL-160	432068-01	1				
11	Cover - Gear Motor	G.S	431532-01	1				

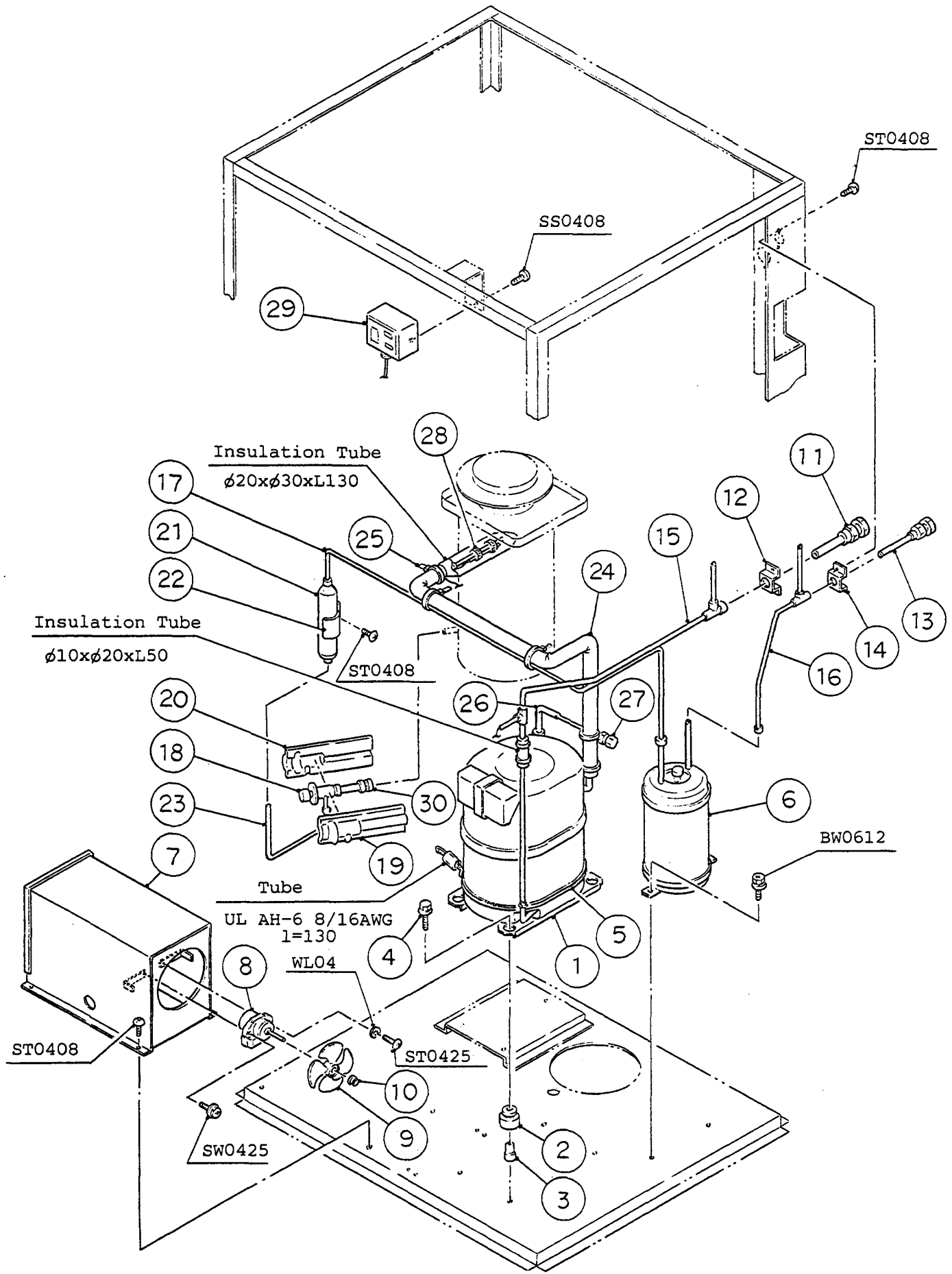

MODEL F-1100MRA		TITLE C. REFRIGERATION UNIT						
INDEX NO.	DESCRIPTION	MATERIAL OR MODEL NUMBER	PART NUMBER	REQ'D NUMBER				
				K-1	A-0	B-0	B-1	C-0
1	Compressor	REK3-0125-PFV	434209-01	1	1	1	1	1
2	Grommet	527-0039-04	434403-01	4	4	4	4	4
3	Spacer	527-0039-04	434404-01	4	4	4	4	4
4	Bolt	M8x50	436206-01	4	4	4	4	4
5	Crankcase Heater	018-0038-00	434186-01	1	1	1	1	1
6	Receiver Tank	RT-P-HD-4	429341-01	1	1	1	1	1
7	Shroud	G.S	315927G01	1	1	1	1	1
8	Fan Motor	MS17ZJF-HJA7	3U0050-01	1	1	1	1	1
9	Fan Blade	ABS	419547-01	1	1	1	1	1
10	Fan Ring	S.S	419547F01	1	1	1	1	1
11	Coupling (Male)	-	434132G01	1	1	1	1	1
12	Tube Holder	G.S	434104-01	1	1	1	1	1
13	Coupling	-	433751G01	1	1	1	1	1
14	Bracket	G.S	425507-01	1	1	1	1	1
15	Copper Tube (A) - High Side	Copper	324939G01	1	1	1	1	1
16	Copper Tube (B) - High Side	Copper	324940G01	1	1	1	1	1
17	Copper Tube (C) - High Side	Copper	324941-01	1	1	1	1	1
18	Expansion Valve	HFE-10RHD-3	433534-03	1	1	1	1	1
19	Cover (A) - EXPV.	PE	324313-01	1	1	1	1	1
20	Cover (B) - EXPV.	PE	324313-02	1	1	1	1	1
21	Drier	KC-6749	427061-01	1	1	1	1	1
22	Strap	G.S	425280-02	1	1	1	1	1
23	Copper Tube (J) - High Side	Copper	425286-03	1	1	1	1	1
24	Copper Tube - Low Side	Copper	324942G01	1	1	1	1	1
25	Tie	CV-150	7920-0003	12	12	12	12	12
26	Copper Tube - Access Valve	Copper	437909-01	1	1	1	1	1
27	Access Valve	TCJ-2FS15-HD	417366-01	1	1	1	1	1
28	Clamp	D11-S	435254-04	2	2	2	2	2
29	Pressure Switch	SNS-2CT130YQ3	425679-01	1	1	1	1	1
30	Socket	Copper	436578-01	1	1	1	1	1

MODEL F-1100MRA		TITLE C. REFRIGERATION UNIT						
INDEX NO.	DESCRIPTION	MATERIAL OR MODEL NUMBER	PART NUMBER	REQ'D NUMBER				
				C-1				
1	Compressor	REK3-0125-PFV	434209-01	1				
2	Grommet	527-0039-04	434403-01	4				
3	Spacer	527-0039-04	434404-01	4				
4	Bolt	M8x50	436206-01	4				
5	Crankcase Heater	018-0038-00	434186-01	1				
6	Receiver Tank	RT-P-HD-4	429341-01	1				
7	Shroud	G.S	315927G01	1				
8	Fan Motor	MS17ZJF-HJA7	3U0050-01	1				
9	Fan Blade	ABS	419547-01	1				
10	Fan Ring	S.S	419547F01	1				
11	Coupling (Hale)	-	434132G01	1				
12	Tube Holder	G.S	434104-01	1				
13	Coupling	-	433751G01	1				
14	Bracket	G.S	425507-01	1				
15	Copper Tube (A) - High Side	Copper	324939G01	1				
16	Copper Tube (B) - High Side	Copper	324940G01	1				
17	Copper Tube (C) - High Side	Copper	324941-01	1				
18	Expansion Valve	HFE-10RHD-3	433534-03	1				
19	Cover (A) - EXPV.	PE	324313-01	1				
20	Cover (B) - EXPV.	PE	324313-02	1				
21	Drier	KC-6749	427061-01	1				
22	Strap	G.S	425280-02	1				
23	Copper Tube (J) - High Side	Copper	425286-03	1				
24	Copper Tube - Low Side	Copper	324942G01	1				
25	Tie	CV-150	7920-0003	12				
26	Copper Tube - Access Valve	Copper	437909-01	1				
27	Access Valve	TCJ-2FS15-HD	417366-01	1				
28	Clamp	D11-S	435254-04	2				
29	Pressure Switch	SNS-2CT130YQ3	425679-01	1				
30	Socket	Copper	436578-01	1				

MODEL F-1100MRA		TITLE D. WATER CIRCUIT						
INDEX NO.	DESCRIPTION	MATERIAL OR MODEL NUMBER	PART NUMBER	REQ'D NUMBER				
				K-1	A-0	B-0	B-1	C-0
J	FITTING (K) ASSY	(S-0331)	310978A01	1	1	1	1	1
1	Pipe - Water Supply	S.S	425287G01	1	1	1	1	1
2	Packing	NBR	413854-03	1	1	1	1	1
3	Water Valve	J246-086	3U0065-01	1	1	1	1	1
4	Bracket - Water Valve	G.S	425288-01	1	1	1	1	1
5	Bracket – Reservoir	G.S	315744-01	1	1	1	1	1
6	Reservoir	ABS	208125-02	1	1	1	1	1
7	Separator – Reservoir	ABS	423538-02	1	1	1	1	1
8	Collar	S.S	423416-01	1	1	1	1	1
9	Cover – Reservoir	ABS	208126-02	1	1	1	1	1
10	Float Switch	TW-1221-101	435490-01	1	1	1	1	1
11	Hose - Water Supply	EVA	425289-01	1	1	1	1	1
12	Cover – Reservoir Inlet	S.I.R	415094-01	1	1	1	1	1
13	Hose - Water Supply	EPDM	428615-05	1	1	1	1	1
14	Pipe - Drain	S.S	425292G01	1	1	1	1	1
15	Cap - Drain	Brass	425293-01	1	1	1	1	1
16	Packing - Drain	Sy.R	425294-01	1	1	1	1	1
17	Clamp	MH-30N	421642-04	2	2	2	2	2
18	Clamp	SK-17	435934-05	1	1	1	1	1
19	Clamp	SK-18.3	435934-06	1	1	1	1	1
20	Clamp	CV-150	7920-0003	3	3	3	3	3
21	Clamp	SK-25	435934-07	1	1	1	1	1

MODEL F-1100MRA		TITLE D. WATER CIRCUIT			REQ'D NUMBER				
INDEX NO.	DESCRIPTION	MATERIAL OR MODEL NUMBER	PART NUMBER	C-1					
J	FITTING (K) ASSY	(S-0331)	310978A01	1					
1	Pipe - Water Supply	S.S	425287G01	1					
2	Packing	NBR	413854-03	1					
3	Water Valve	J246-086	3U0065-01	1					
4	Bracket - Water Valve	G.S	425288-01	1					
5	Bracket – Reservoir	G.S	315744-01	1					
6	Reservoir	ABS	208125-02	1					
7	Separator - Reservoir	ABS	423538-02	1					
8	Collar	S.S	423416-01	1					
9	Cover – Reservoir	ABS	208126-02	1					
10	Float Switch	TW-1221-101	435490-01	1					
11	Hose - Water Supply	EVA	425289-01	1					
12	Cover – Reservoir Inlet	SI.R	415094-01	1					
13	Hose - Water Supply	EPDM	428615-05	1					
14	Pipe – Drain	S.S	425292G01	1					
15	Cap – Drain	Brass	425293-01	1					
16	Packing – Drain	Sy.R	425294-01	1					
17	Clamp	MH-30N	421642-04	2					
18	Clamp	SK-17	435934-05	1					
19	Clamp	SK-18.3	435934-06	1					
20	Clamp	CV-150	7920-0003	3					
21	Clamp	SK-25	435934-07	1					

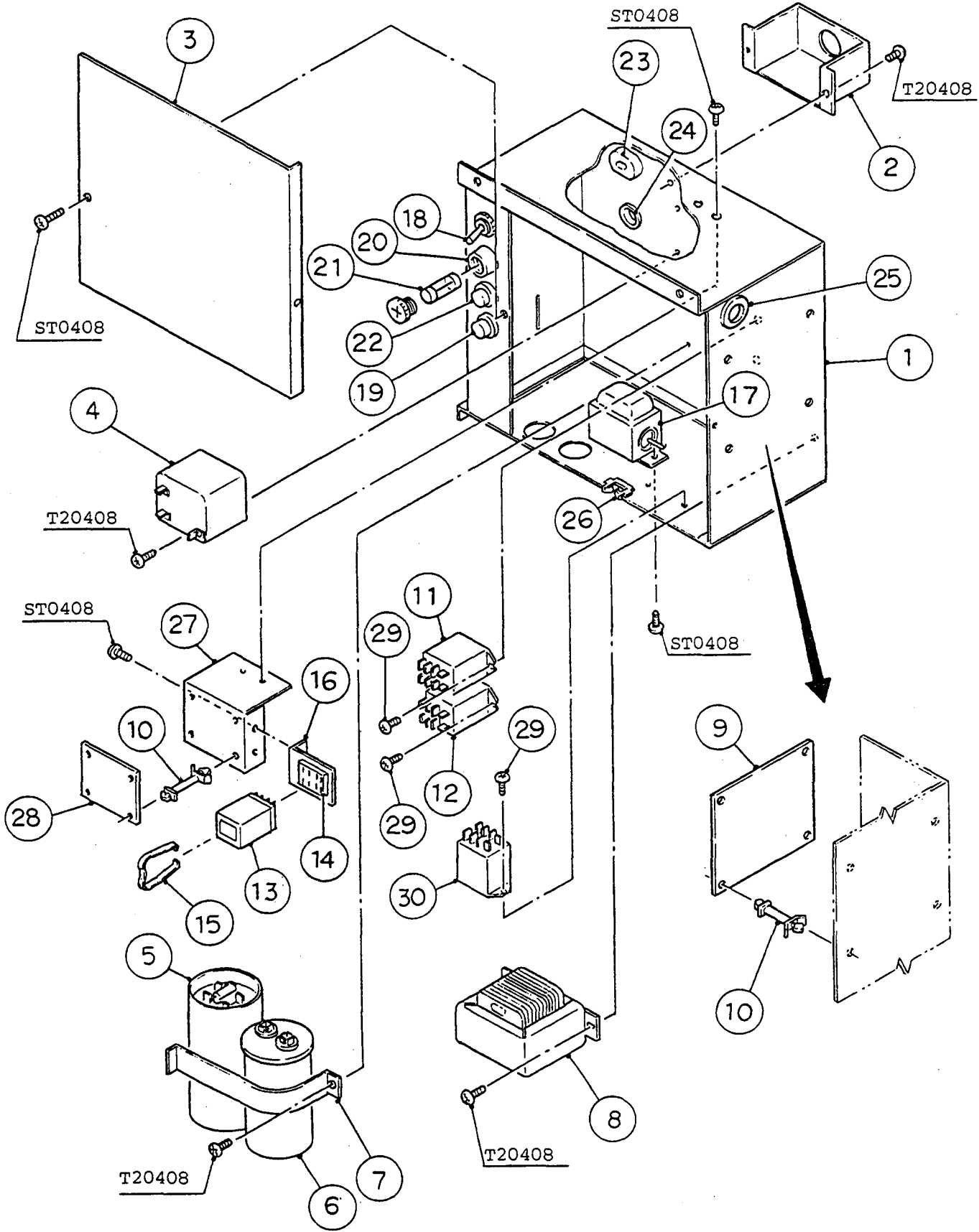

MODEL F-1100MRA		TITLE E. CONTROL BOX ASSY			REQ'D NUMBER				
INDEX NO.	DESCRIPTION	MATERIAL OR MODEL NUMBER	PART NUMBER	K-1	A-0	B-0	B-1	C-0	
				1	Control Box	G.S	315746G09	1	1
2	Cover - Connector	G.S	425302-01	1	1	1	1	1	
3	Cover - Control Box	G.S	425301-01	1	1	1	1	1	
4	Starter	040-0001-26	434172-01	1	1	1	1	1	
5	Start Capacitor	014-0008-78	434171-02	1	1	1	1	1	
6	Run Capacitor	014-0037-09	434170-01	1	1	1	1	1	
7	Strap - Capacitor	G.S	431394-03	1	1	1	1	1	
8	Transformer	TR5268	2U0041-01	1	1	1	1	1	
9	Timer Board	H2AA144C01	437305-01	1	1	1	1	1	
10	Board Support	KGLS-6S	414929-01	8	8	8	8	8	
11	Relay	LY1F	418271-04	2	2	2	2	2	
12	Relay	LY2ZF	406132-06	1	1	1	1	1	
13	Keep Relay	MY2K-HO	418524-03	1	1	1	1	1	
14	Socket - Relay	PY-14	408328-02	1	1	1	1	1	
15	Clamp - Relay	PYC-P	411353-01	1	1	1	1	1	
16	Bracket - Relay	G.S	425300-01	1	1	1	1	1	
17	Thermostat	A10-9756	420465-01	1	1	1	1	1	
18	Toggle Switch	S-821	438030-01	1	1	1	1	1	
19	Push Button Switch	SB-4011N/OT3959	420466-01	1	1	1	1	1	
20	Fuse Holder	FH032	424288-01	1	1	1	1	1	
21	Fuse	FGA0-2, 1A	420468-03	1	1	1	1	1	
22	Overload - Gear Motor	W58xBIA4A-2	425201-01	1	1	1	1	1	
23	Bushing	SR-7P-2	420472-07	1	1	1	1	1	
24	Bushing	SB-625-8	420470-01	1	1	1	1	1	
25	Bushing	SB-1093-15	420470-03	1	1	1	1	1	
26	Edge Saddle	EDS-1	421552-01	1	1	1	1	1	
27	Beeper Bracket	G.S	323312-01	1	1	1	1	1	
28	Beeper	-	435937-01	1	1	1	1	1	
29	Tapping Screw	3x8	431415-01	6	6	6	6	6	
30	Relay	LY2F AC240V	406132-08	1	1	1	1	1	

MODEL F-1100MRA		TITLE E. CONTROL BOX ASSY						
INDEX NO.	DESCRIPTION	MATERIAL OR MODEL NUMBER	PART NUMBER	REQ'D NUMBER				
				C-1				
1	Control Box	G.S	315746G09	1				
2	Cover - Connector	G.S	425302-01	1				
3	Cover - Control Box	G.S	425301-01	1				
4	Starter	040-0001-26	434172-01	1				
5	Start Capacitor	014-0008-78	434171-02	1				
6	Run Capacitor	014-0037-09	434170-01	-				
			434170-05	1				
7	Strap - Capacitor	G.S	431394-03	-				
			431394-01	1				
8	Transformer	TR5268	2U0041-01	1				
9	Timer Board	H2AA144C01	437305-01	1				
10	Board Support	KGLS-6S	414929-01	8				
11	Relay	LY1F	418271-04	2				
12	Relay	LY2ZF	406132-06	1				
13	Keep Relay	MY2K-HO	418524-03	1				
14	Socket - Relay	PY-14	408328-02	1				
15	Clamp - Relay	PYC-P	411353-01	1				
16	Bracket - Relay	G.S	425300-01	1				
17	Thermostat	A10-9756	420465-01	1				
18	Toggle Switch	S-821	438030-01	1				
19	Push Button Switch	SB-4011N/0T3959	420466-01	1				
20	Fuse Holder	FH032	424288-01	1				
21	Fuse	FGA0-2, 1A	420468-03	1				
22	Overload - Gear Motor	W58xBIA4A-2	425201-01	1				
23	Bushing	SR-7P-2	420472-07	1				
24	Bushing	SB-625-8	420470-01	1				
25	Bushing	SB-1093-15	420470-03	1				
26	Edge Saddle	EDS-1	421552-01	1				
27	Beeper Bracket	G.S	323312-01	1				
28	Beeper	-	435937-01	1				
29	Tapping Screw	3x8	431415-01	6				
30	Relay	LY2F AC240V	406132-08	1				

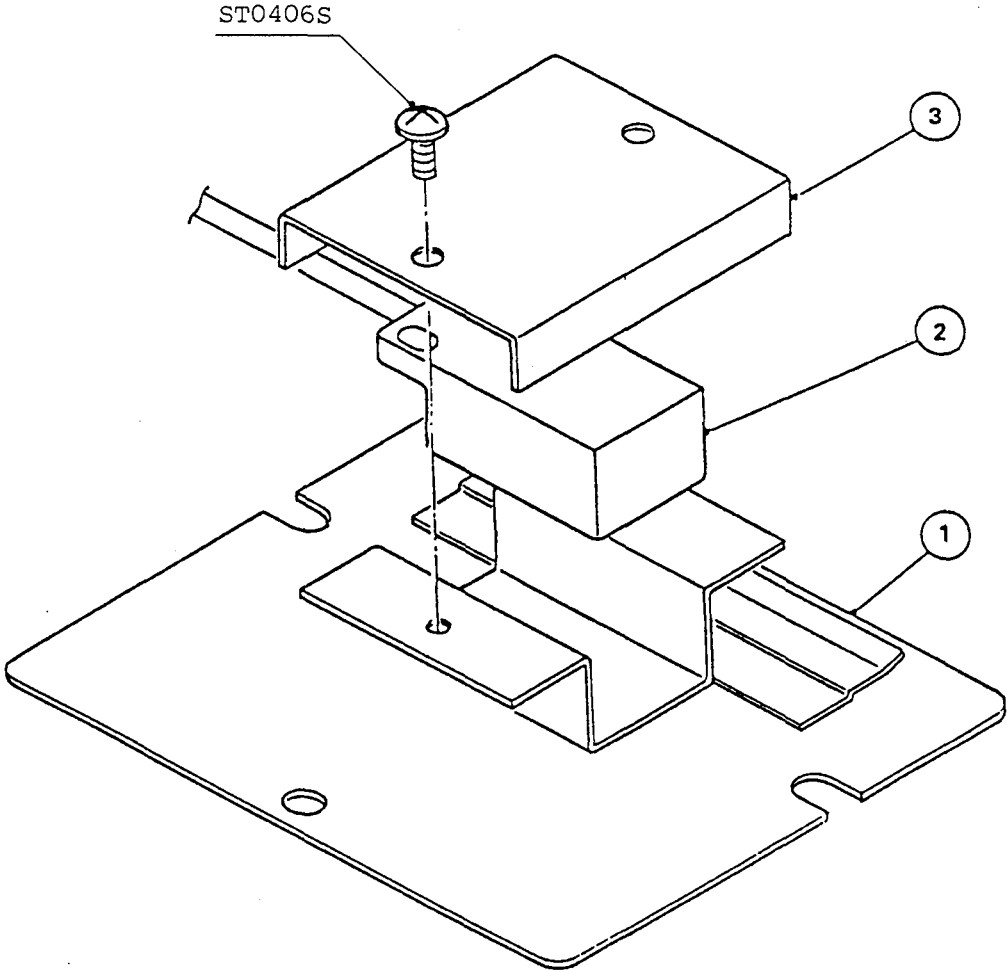

MODEL		TITLE						
F-1101MRA		F. BIN SWITCH ASSY						
INDEX NO.	DESCRIPTION	MATERIAL OR MODEL NUMBER	PART NUMBER	REQ'D NUMBER				
				K-1	A-0	B-0	B-1	C-0
1	Bracket - Switch	S.S.	317648G01	1	1	1	1	1
2	Proximity Switch - Bin Control	RS-601	427223-01	1	1	1	1	1
3	Bracket - Proximity Switch	S.S	427158-01	1	1	1	1	1

MODEL		TITLE						
F-1101MRA		F. BIN SWITCH ASSY						
INDEX NO.	DESCRIPTION	MATERIAL OR MODEL NUMBER	PART NUMBER	REQ'D NUMBER				
				C-1				
1	Bracket - Switch	S.S.	317648G01	1				
2	Proximity Switch - Bin Control	RS-601	427223-01	1				
3	Bracket - Proximity Switch	S.S	427158-01	1				

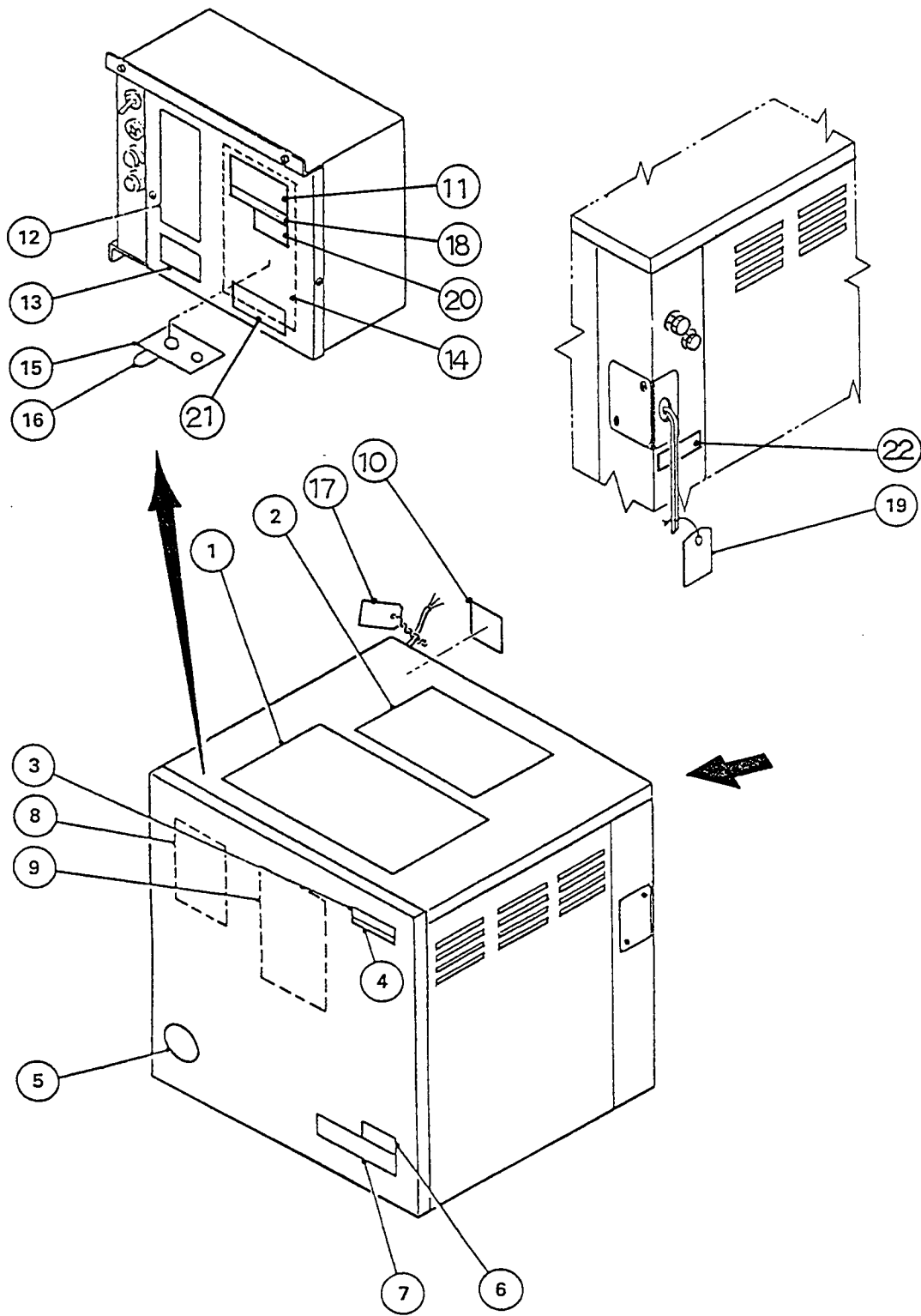

MODEL TITLE
F-1100MRA G. LABEL LOCATION

INDEX NO.	DESCRIPTION	MATERIAL OR MODEL NUMBER	PART NUMBER	REQ'D NUMBER				
				K-1	A-0	B-0	B-1	C-0
1	Instruction Sheet - Inst. Ope.	Paper	208144-01	1	1	1	1	1
2	Instruction Sheet - Bin Inst.	Paper	208145-01	1	1	1	1	1
3	Emblem (L) - HOSHIZAKI	ABS	418634G01	1	1	1	1	1
4	Label - Model Number	PETP Film	435985-18	1	1	1	1	1
5	Label - Penguin	PETP Film	410994-01	1	1	1	1	1
6	Label - Warning	PVC Film	425323-01	x1				
	Caution Label (F)		439146-01	o1	1	1	1	1
7	Label - Operation, Spout Cont.	PETP Film	425325-01	x1				
	Instruction Label		443470-01	o1	1	1	1	1
8	Label - Operation	PVC Film	316381-01	1	1	1	1	1
9	Label - Cleaning	PVC Film	214783-01	1	1	1	1	1
10	Nameplate	PES Film	438062-01	1	1	1	1	1
11	Rating Label	PES Film	438065-01	1	1	1	1	1
12	Label - Control	PETP Film	438059-01	1	1	1	1	1
13	Label - Danger	PVC Film	425322-01	x1				
	Caution Label (C)		439143-01	o1	1	1	1	1
14	Wiring Label	PVC Film	324880-01	1	1	1	1	1
15	Label - Bin Thermostat	PETP Film	435984-01	1	1	1	1	1
16	Label - Factory Adjusted	PETP Film	419404-01	1	1	1	1	1
17	Tag - Caution: Connection	PETP Film	420743-01	1	1	1	1	1
18	Label - Charge	PES Film	324977-01	1	1	1	1	1
19	Tag - Fan Motor Leads	Paper	420742-01	1	1	1	1	1
20	Label - R502	PES Film	4A0026-01	1	1	1	1	1
21	Warning Label	PVC Film	435955-01	1	1	1	1	1
22	Label - Connection	PVC Film	438234-01	1	1	1	1	1

MODEL F-1100MRA		TITLE G. LABEL LOCATION							
INDEX NO.	DESCRIPTION	MATERIAL OR MODEL NUMBER	PART NUMBER	REQ'D NUMBER					
				C-1					
1	Instruction Sheet - Inst. Ope.	Paper	208144-01	1					
2	Instruction Sheet - Bin Inst.	Paper	208145-01	1					
3	Emblem (L) - HOSHIZAKI	ABS	418634G01	1					
4	Label - Model Number	PETP Film	435985-18	1					
5	Label - Penguin	PETP Film	410994-01	1					
6	Caution Label (F)	PVC Film	439146-01	1					
7	Instruction Label	PETP Film	443470-01	1					
8	Label - Operation	PVC Film	316381-01	1					
9	Label - Cleaning	PVC Film	214783-01	1					
10	Nameplate	PES Film	438062-01	1					
11	Rating Label	PES Film	438065-01	1					
12	Label - Control	PETP Film	438059-01	1					
13	Caution Label (C)	PVC Film	439143-01	1					
14	Wiring Label	PVC Film	324880-01	1					
15	Label - Bin Thermostat	PETP Film	435984-01	1					
16	Label - Factory Adjusted	PETP Film	419404-01	1					
17	Tag - Caution: Connection	PETP Film	420743-01	1					
18	Label - Charge	PES Film	324977-01	1					
19	Tag - Fan Motor Leads	Paper	420742-01	1					
20	Label - R502	PES Film	4A0026-01	1					
21	Warning Label	PVC Film	435955-01	1					
22	Label - Connection	PVC Film	438234-01	1					

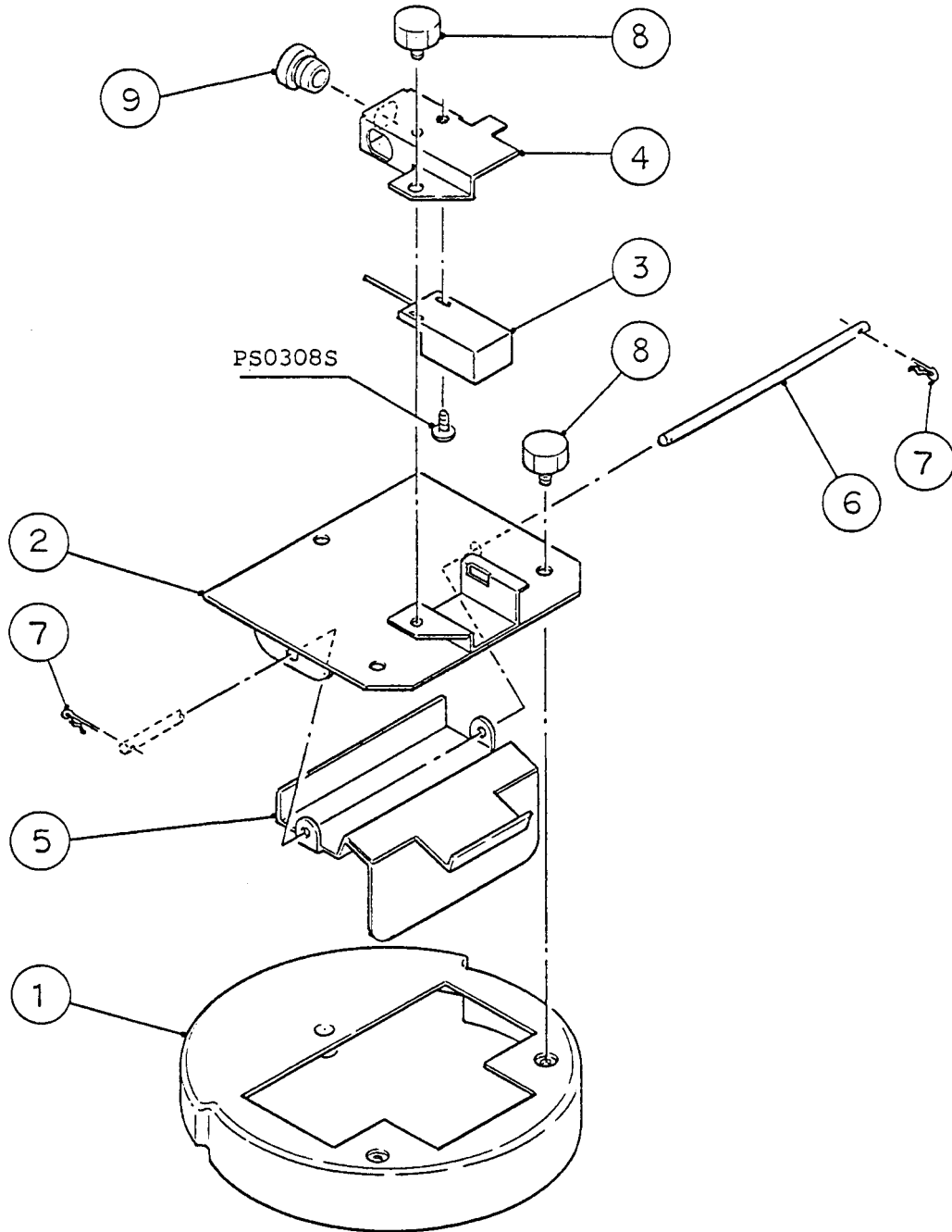

MODEL		TITLE						
F-1100MRA		H. SPOUT CONTROL ASSY						
INDEX NO.	DESCRIPTION	MATERIAL OR MODEL NUMBER	PART NUMBER	REQ'D NUMBER				
				K-1	A-0	B-0	B-1	C-0
1	Cover - Chute	ABS	214796G01	1	1	1	1	1
2	Spout Cover	S.S	325070G01	1	1	1	1	1
3	Proximity Switch	RS-601	427223-01	1	1	1	1	1
4	Cover - Proximity Switch	S.S	324106-01	1	1	1	1	1
5	Paddle	S.S	323310G01	1	1	1	1	1
6	Axle	S.S	435873-01	1	1	1	1	1
7	Snap Pin	S.S, SSP-4	715S-0004	2	2	2	2	2
8	Thumbscrew	ABS, S.S	415949G01	3	3	3	3	3
9	Bushing	SR-5KN-4	420472-06	1	1	1	1	1

MODEL		TITLE						
F-1100MRA		H. SPOUT CONTROL ASSY						
INDEX NO.	DESCRIPTION	MATERIAL OR MODEL NUMBER	PART NUMBER	REQ'D NUMBER				
				C-1				
1	Cover - Chute	ABS	214796G01	1				
2	Spout Cover	S.S	325070G01	1				
3	Proximity Switch	RS-601	427223-01	1				
4	Cover - Proximity Switch	S.S	324106-01	1				
5	Paddle	S.S	323310G01	1				
6	Axle	S.S	435873-01	1				
7	Snap Pin	S.S, SSP-4	715S-0004	2				
8	Thumbscrew	ABS, S.S	415949G01	3				
9	Bushing	SR-5KN-4	420472-06	1				

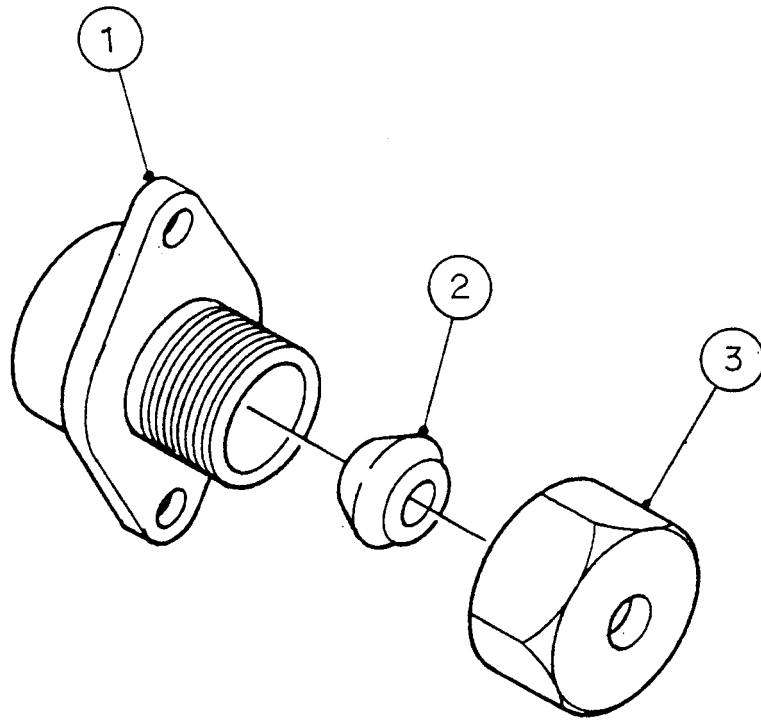

MODEL		TITLE						
F-1100MRA		J. FITTING (K) ASSY						
INDEX NO.	DESCRIPTION	MATERIAL OR MODEL NUMBER	PART NUMBER	REQ'D NUMBER				
				K-1	A-0	B-0	B-1	C-0
1	Fitting (K)	Brass Casting	310978-01	1	1	1	1	1
2	Packing (C)	Sy.R	415715-02	1	1	1	1	1
3	Nut (B)	Brass	415713-02	1	1	1	1	1

MODEL		TITLE						
F-1100MRA		J. FITTING (K) ASSY						
INDEX NO.	DESCRIPTION	MATERIAL OR MODEL NUMBER	PART NUMBER	REQ'D NUMBER				
				C-1				
1	Fitting (K)	Brass Casting	310978-01	1				
2	Packing (C)	Sy.R	415715-02	1				
3	Nut (B)	Brass	415713-02	1				

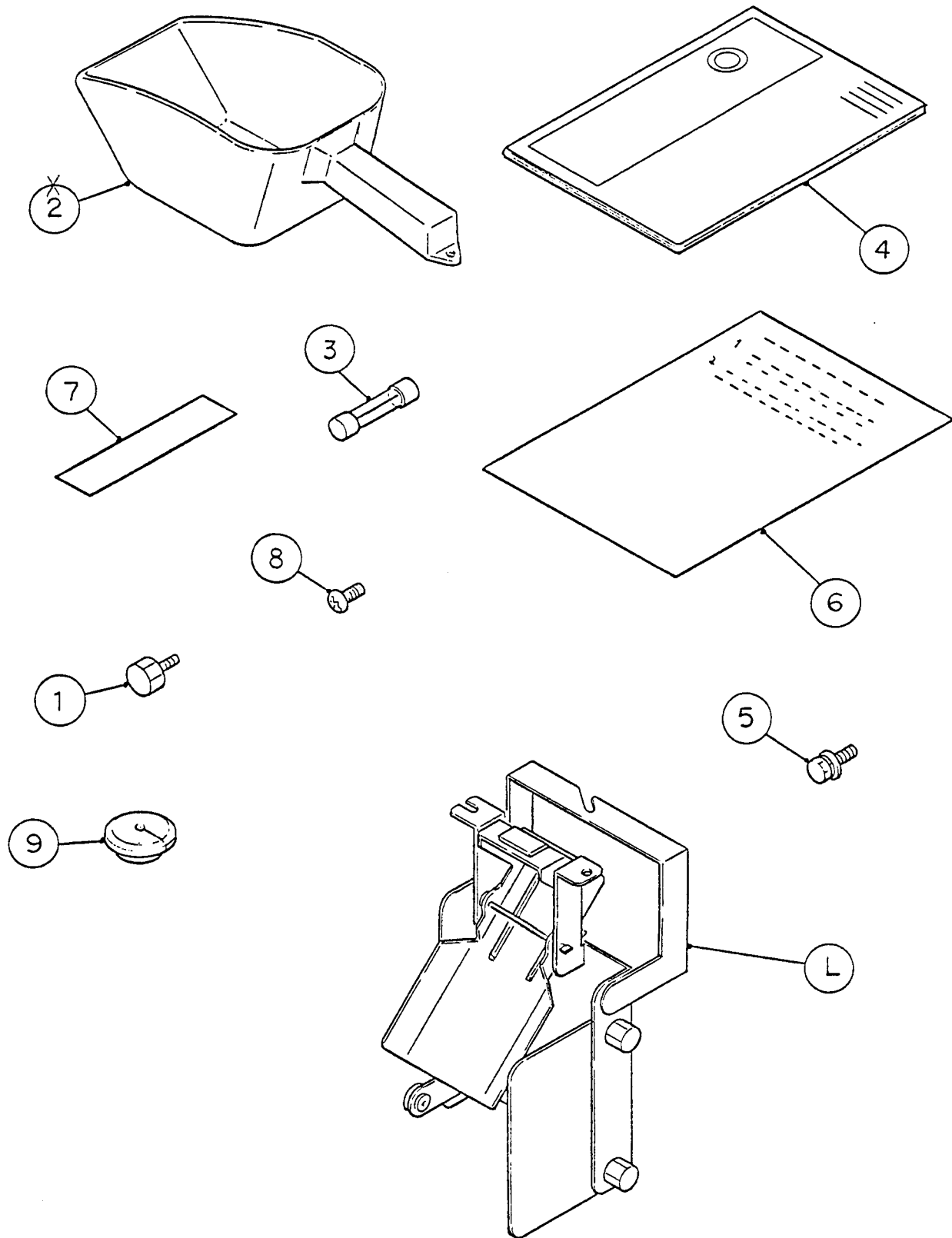

MODEL F-1100MRA		TITLE K. ACCESSORIES						
INDEX NO.	DESCRIPTION	MATERIAL OR MODEL NUMBER	PART NUMBER	REQ'D NUMBER				
				K-1	A-0	B-0	B-1	C-0
J	BIN CONTROL ASSY	-	325073A01	1	1	1	1	1
1	Thumbscrew	S.S, ABS	415949G04	3	3	3	3	3
2	Scoop	PE	208185-01	1	1	1	x1	
3	Fuse	FGA-2, 1A	420468-03	1	1	1	1	1
4	Instruction Manual	Paper	91U2Af10A	1	1	1	1	1
5	Bolt And Washer Assy SW	S.S, M8x16	-	2	2	2	2	2
6	Instruction Sheet - Bin	Paper	323351-01	1	1	1	1	1
	Control							
7	Instruction Sheet - Fastener	Paper	427122-01	1	1	1	1	1
8	Truss Head Machine Screw	S.S, M4x30	-	2	2	2	2	2
9	Bushing - Cappillary Tube	EP Rubber	425307-01	1	1	1	1	1

MODEL F-1100MRA		TITLE K. ACCESSORIES						
INDEX NO.	DESCRIPTION	MATERIAL OR MODEL NUMBER	PART NUMBER	REQ'D NUMBER				
				C-1				
J	BIN CONTROL ASSY	-	325073A01	1				
1	Thumbscrew	S.S, ABS	415949G04	3				
2	-	-	-	-				
3	Fuse	FGA-2, 1A	420468-03	1				
4	Instruction Manual	Paper	91U2Af10A	1				
5	Bolt And Washer Assy SW	S.S, M8x16	-	2				
6	Instruction Sheet - Bin	Paper	323351-01	1				
	Control							
7	Instruction Sheet - Fastener	Paper	427122-01	1				
8	Truss Head Machine Screw	S.S, M4x30	-	2				
9	Bushing - Cappillary Tube	EP Rubber	425307-01	1				

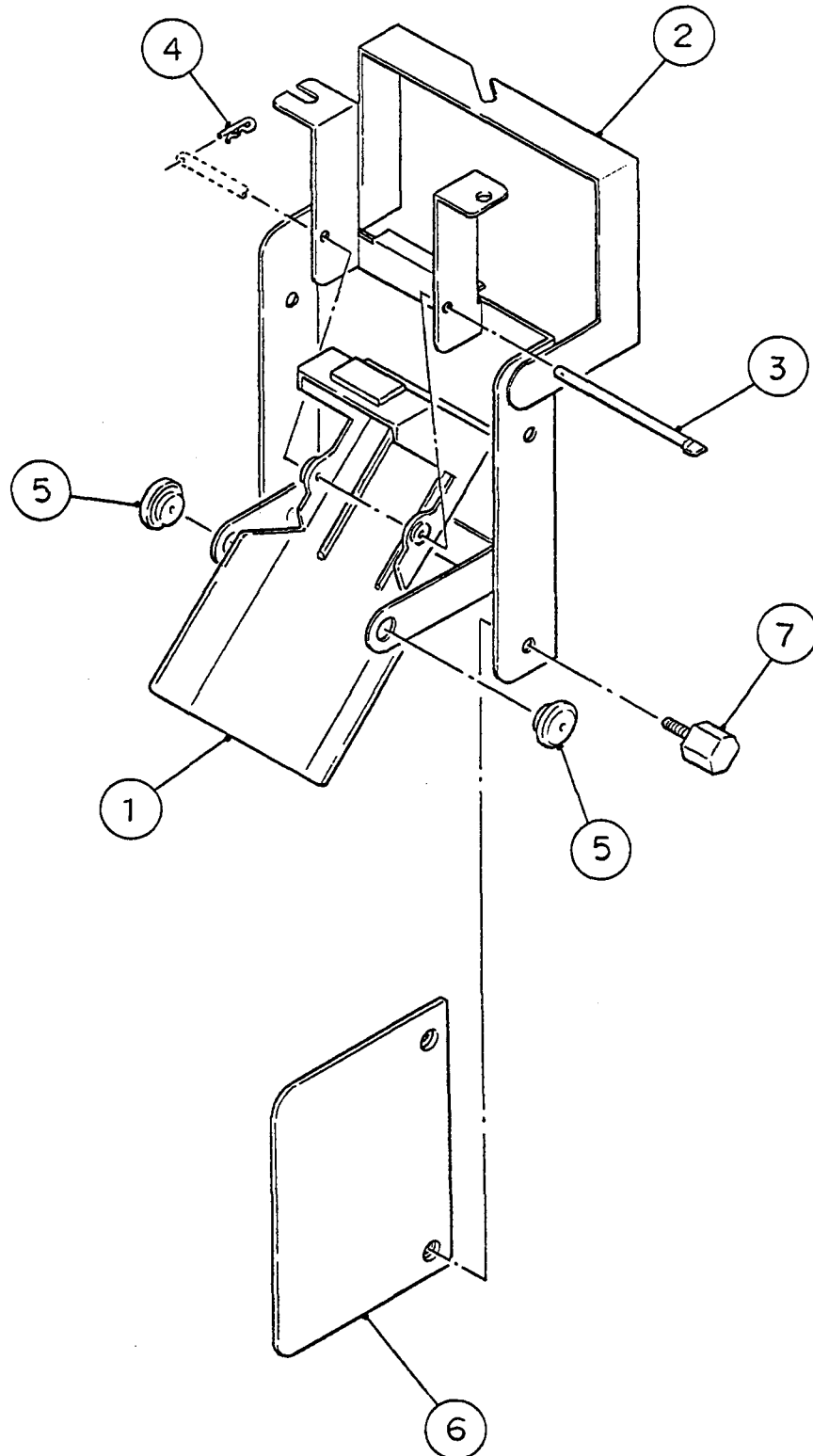

MODEL		TITLE						
F-1100MRA		L. BIN CONTROL ASSY						
INDEX NO.	DESCRIPTION	MATERIAL OR MODEL NUMBER	PART NUMBER	REQ'D NUMBER				
				K-1	A-0	B-0	B-1	C-0
1	Actuator Switch	ABS, S.S	209168G01	1	1	1	1	1
2	Bin Control Bracket	S.S	325072G01	1	1	1	1	1
3	Shaft	-	412337-03	1	1	1	1	1
4	Snap Pin	S.S	715S-0004	1	1	1	1	1
5	Bushing - Capillary Tube	S.S, SSP-4	425307-01	2	2	2	2	2
6	Paddle Cover	PC	438297G01	1	1	1	1	1
7	Thumbscrew	ABS, S.S	415949G01	2	2	2	2	2

MODEL		TITLE						
F-1100MRA		L. BIN CONTROL ASSY						
INDEX NO.	DESCRIPTION	MATERIAL OR MODEL NUMBER	PART NUMBER	REQ'D NUMBER				
				C-1				
1	Actuator Switch	ABS, S.S	209168G01	1				
2	Bin Control Bracket	S.S	325072G01	1				
3	Shaft	-	412337-03	1				
4	Snap Pin	S.S	715S-0004	1				
5	Bushing - Capillary Tube	S.S, SSP-4	425307-01	2				
6	Paddle Cover	PC	438297G01	1				
7	Thumbscrew	ABS, S.S	415949G01	2				