



HOSHIZAKI

MODULAR FLAKER

MODEL

F-1100MWA

PARTS LIST FINAL

ISSUED:	MAY 28, 1990
REVISED:	NOV. 16, 1993
PRINTED:	JULY 27, 1995
ITEM NO:	71036

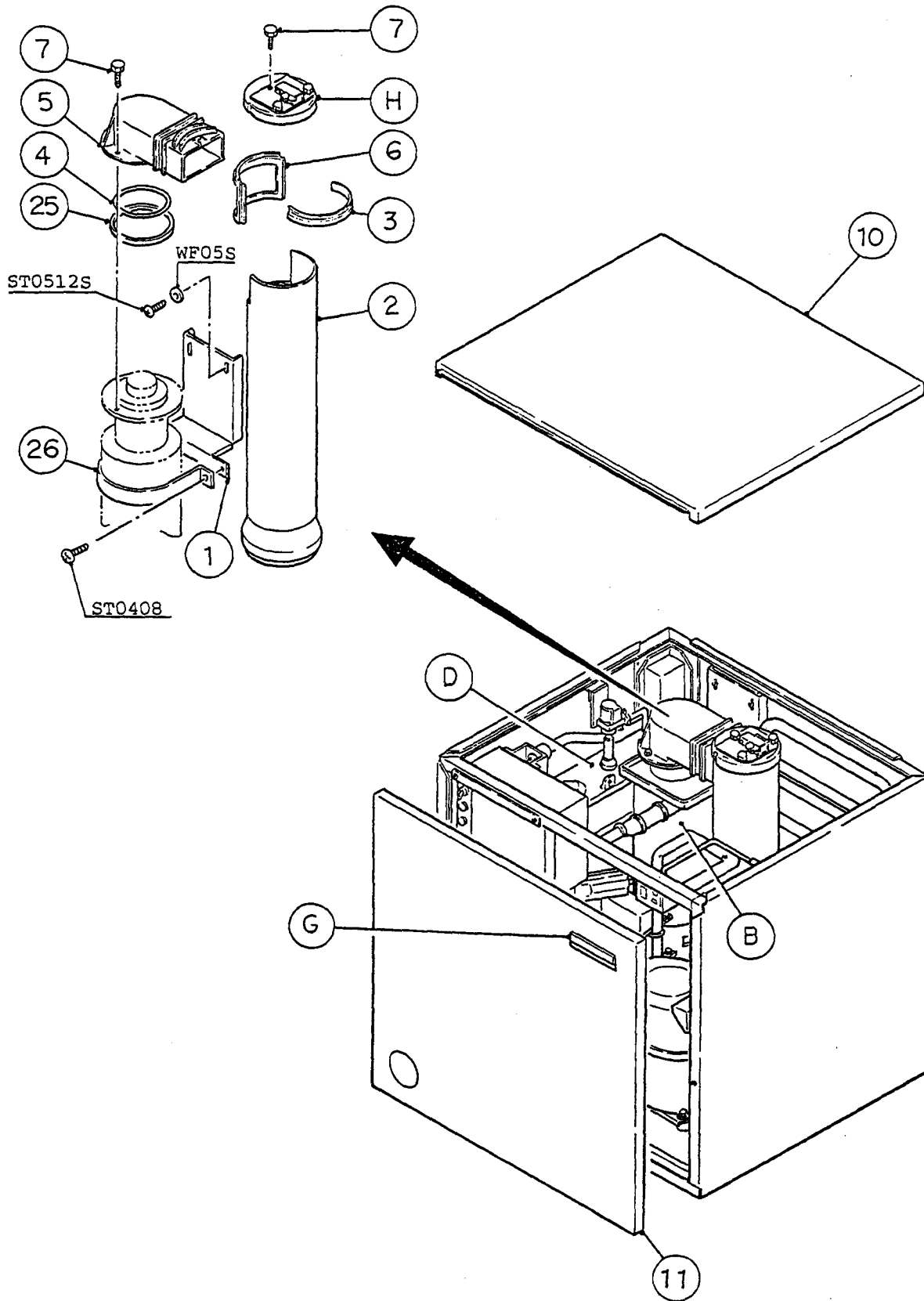

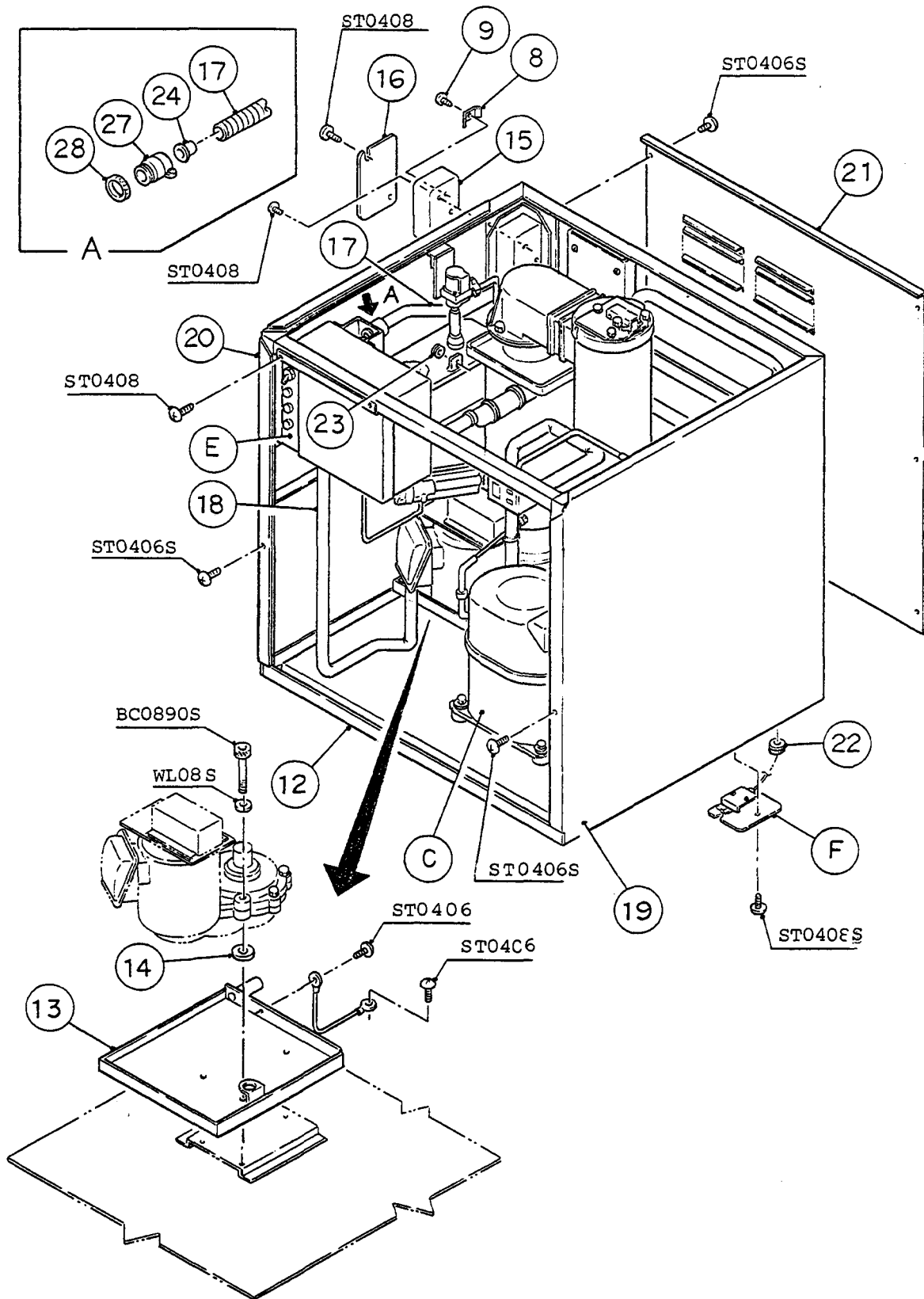

MODEL		TITLE						
F-1100MWA		A. ICE FLAKER ASSY						
INDEX NO.	DESCRIPTION	MATERIAL OR MODEL NUMBER	PART NUMBER	REQ'D NUMBER				
				K-1	A-0	B-0	C-1	C-2
B	EVAPORATOR ASSY	-	319958A03	1	1	1	1	1
C	REFRIGERATION UNIT	-	104902A01	1	1	1	-	
			104902A02				1	1
D	WATER CIRCUIT	-	103078A04	1	1	1	1	1
E	CONTROL BOX ASSY	-	214652A02	1	1	1	1	-
			214652A05					1
F	BIN SWITCH ASSY	-	317679A01	1	1	1	1	1
G	LABEL LOCATION	-	213149A05	1	1	1	1	1
H	SPOUT CONTROL ASSY	-	325071A01	1	1	1	1	1
1	Bracket - Evaporator	G.S	431735-01	1	1	1	1	1
2	Chute	PE	315723-01	1	1	1	1	1
3	Packing - Chute	EPDM	425255-01	1	1	1	1	1
4	"O" Ring	G95	7616-G095	1	1	1	1	1
5	Spout	PC	103932G01	1	1	1	1	1
6	Packing - Spout	EPDM	315722-01	1	1	1	1	1
7	Thumbscrew	S.S, ABS	415949G03	4	4	4	4	4
8	Square Washer	Copper	433537-01	1	1	1	1	1
9	Screw - Grounding	Brass	433304-01	1	1	1	1	1
10	Top Panel	S.S	315750G01	1	1	1	-	
			315750G02				1	1
11	Front Panel	S.S	315937-02	1	1	1	-	
			315937-03				1	1
12	Frame	G.S	315778G06	1	1	1	1	1
13	Drip Pan	S.S	317168G01	1	1	1	1	1
14	Washer	PVC	422916-01	3	3	3	3	3
15	Junction Box	No.6001	421587-01	1	1	1	1	1
16	Cover - Junction Box	G.S	420594-01	1	1	1	1	1
17	Conduit	-	429313-02	1	1	1	1	1
18	Conduit	-	429313-01	1	1	1	1	1
19	Side Panel (Right)	S.S	316033G01	1	1	1	-	
			316033G02				1	1
20	Side Panel (Left)	S.S	315748G02	1	1	1	-	
			315748G03				1	1
21	Rear Panel	S.S	316034-02	1	1	1	1	1

MODEL		TITLE						
F-1100MWA		A. ICE FLAKER ASSY						
INDEX NO.	DESCRIPTION	MATERIAL OR MODEL NUMBER	PART NUMBER	REQ'D NUMBER				
				K-1	A-0	B-0	C-1	C-2
22	Bushing	SB-437-5	420470-07	1	1	1	1	1
23	Bushing	SR-30-1	420472-03	1	1	1	1	1
24	Collar	Steel	430335-01	4	4	4	4	4
25	Ring	PA	431736-01	1	1	1	1	1
26	Strap	G.S	431737-01	1	1	1	1	1
27	Fitting – Conduit	NS-1621	435753-01	4	4	4	4	4
28	Nut	t3.6	435753F01	4	4	4	4	4

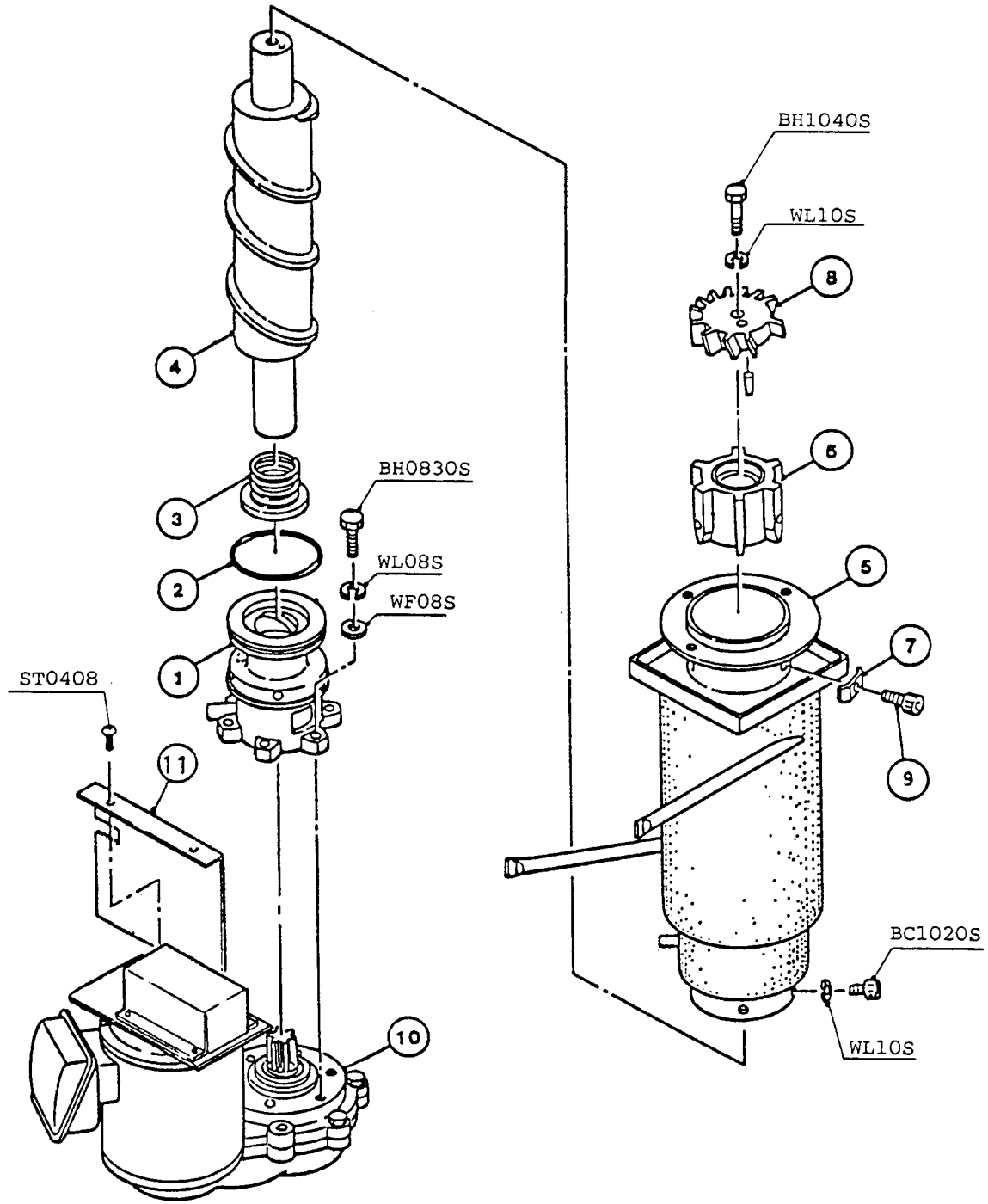

MODEL		TITLE						
F-1100MWA		B. EVAPORATOR ASSY						
INDEX NO.	DESCRIPTION	MATERIAL OR MODEL NUMBER	PART NUMBER	REQ'D NUMBER				
				K-1	A-0	B-0	C-1	C-2
1	Bearing (Lower)	-	315732G02	1	1	1	1	1
2	"O" Ring	G90	7616-G090	1	1	1	1	1
3	Mechanical Seal	HK9A-MN	432493-01	1	1	1	1	1
4	Auger	S.S	211062G01	1	1	1	1	1
5	Evaporator	-	425273G04	1	1	1	1	1
6	Extruding Head	S.S	208117G02	1	1	1	1	1
7	Washer	S.S	425277-01	3	3	3	3	3
8	Cutter	S.S	315734-01	1	1	1	1	1
9	Socket Head Cap Screw	S.S, M10	429121-02	3	3	3	3	3
10	Gear Motor	MGZ2200UL-160	432068-01	1	1	1	1	1
11	Cover - Gear Motor	G.S	431532-01	1	1	1	1	1

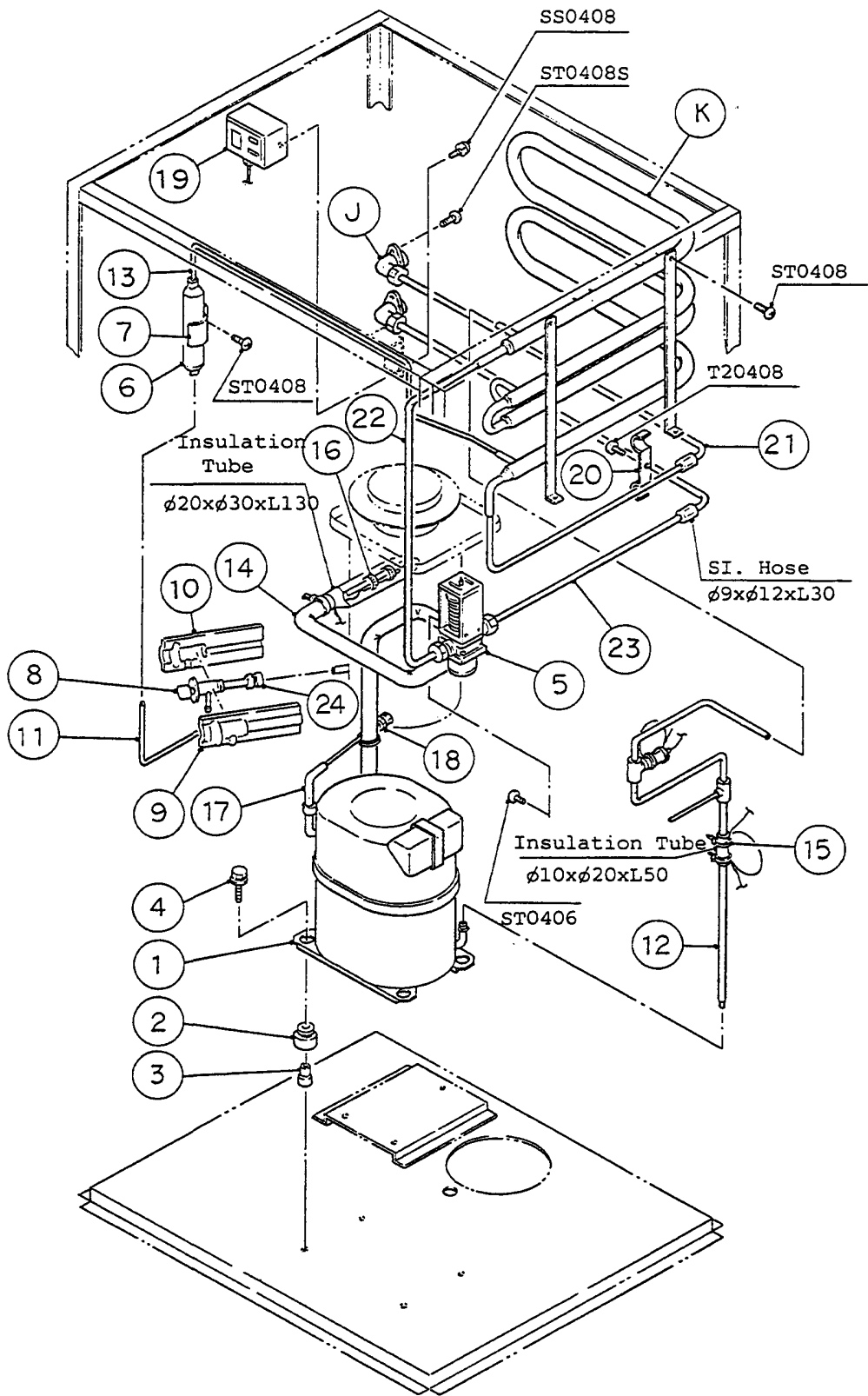

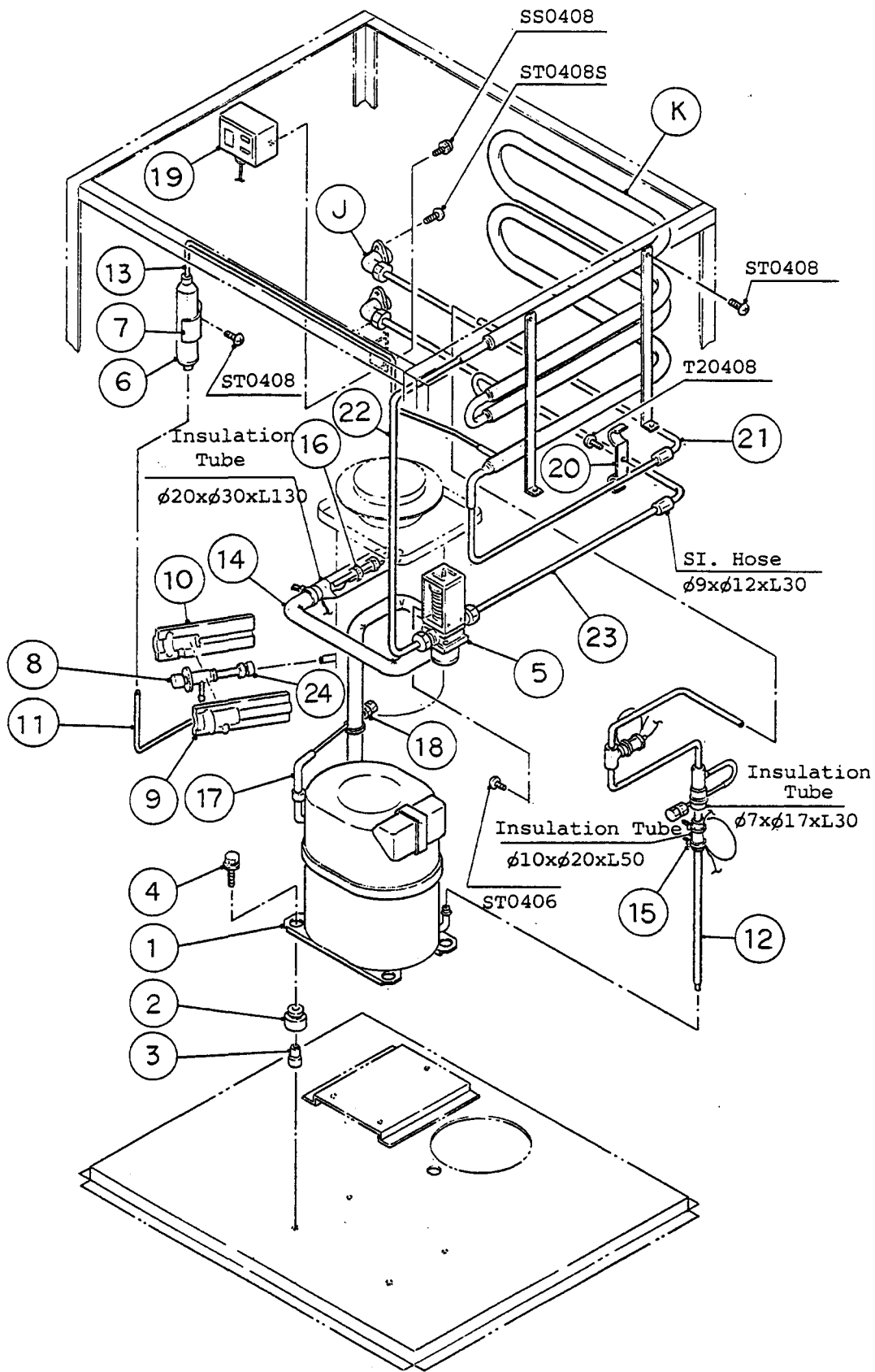

MODEL F-1100MWA		TITLE C. REFRIGERATION UNIT						
INDEX NO.	DESCRIPTION	MATERIAL OR MODEL NUMBER	PART NUMBER	REQ'D NUMBER				
				K-1	A-0	B-0	C-1	C-2
J	FITTING (U) ASSY	(S-0382)	314347A01	2	2	2	2	2
K	CONDENSER - WATER-COOLED	(S-0697)	214692A01	1	1	1	1	1
1	Compressor	REK3-0125-PFV	434209-01	1	1	1	1	1
2	Grommet	527-0039-04	434403-01	4	4	4	4	4
3	Spacer	527-0039-04	434404-01	4	4	4	4	4
4	Bolt	8x50	436206-01	4	4	4	4	4
5	Water Regulator	WVII-33RHD	415425-01	1	1	1	1	1
6	Drier	KC-6749	427061-01	1	1	1	1	1
7	Strap	G.S	425280-02	1	1	1	1	1
8	Expansion Valve	HFE-10RHD-3	433534-03	1	1	1	1	1
9	Cover (A) - EXPV.	PE	324313-01	1	1	1	1	1
10	Cover (B) - EXPV.	PE	324313-02	1	1	1	1	1
11	Copper Tube (J) - High Side	Copper	425286-03	1	1	1	1	1
12	Copper Tube (A) - High Side	Copper	324943G01	1	1	1	-	
			219020G01				1	1
13	Copper Tube (B) - High Side	Copper	324944-01	1	1	1	1	1
14	Copper Tube - Low Side	Copper	324945G01	1	1	1	1	1
15	Tie	CV-150	7920-0003	9	9	9	9	9
16	Clamp	D11-S	435254-04	2	2	2	2	2
17	Copper Tube - Access Valve	Copper	437909-01	1	1	1	1	1
18	Access Valveide	TCJ-2FS15-HD	417366-01	1	1	1	1	1
19	Pressure Switch	SNS-2CT130YQ3	425679-01	1	1	1	1	1
20	Strap	G.S	425668-01	1	1	1	1	1
21	Pipe (A)	Copper	425675-01	1	1	1	1	1
22	Copper Tube (B) - Water-cooled	Copper m	438108G01	1	1	1	1	1
23	Copper Tube (A) - Water-cooled	Copper	438109G01	1	1	1	1	1
24	Socket	Copper	436578-01	1	1	1	1	1

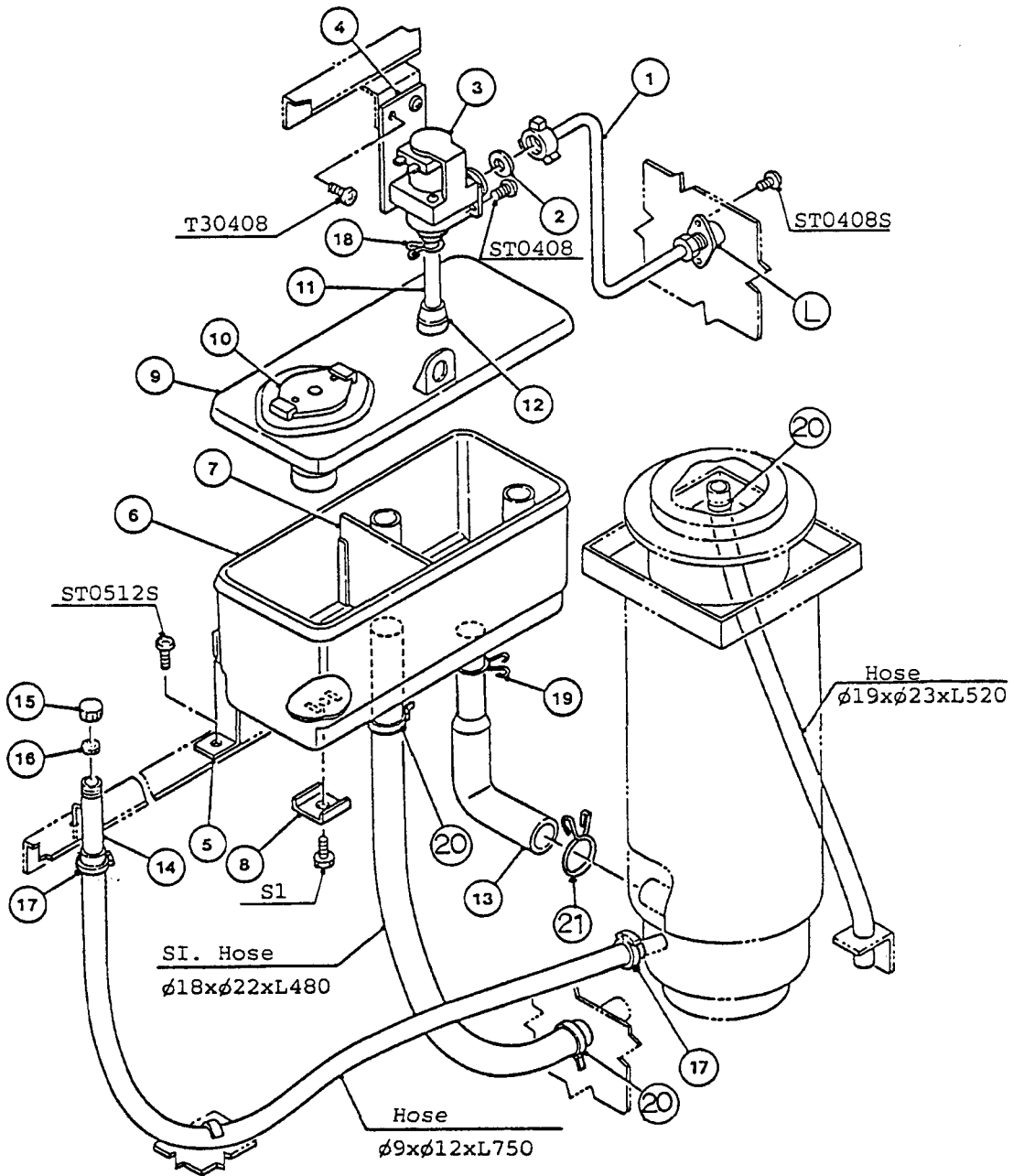

FASTENER

SI - Thumbscrew, M4x6

MODEL		TITLE						
F-1100MWA		D. WATER CIRCUIT						
INDEX NO.	DESCRIPTION	MATERIAL OR MODEL NUMBER	PART NUMBER	REQ'D NUMBER				
				K-1	A-0	B-0	C-1	C-2
L	FITTING (K) ASSY	(S-0331)	310978A01	1	1	1	1	1
1	Pipe - Water Supply	S.S	425287G01	1	1	1	1	1
2	Packing	NBR	413854-03	1	1	1	1	1
3	Water Valve	J246-086	3U0065-01	1	1	1	1	1
4	Bracket - Water Valve	G.S	425288-01	1	1	1	1	1
5	Bracket – Reservoir	G.S	315744-01	1	1	1	1	1
6	Reservoir	ABS	208125-02	1	1	1	1	1
7	Separator – Reservoir	ABS	423538-02	1	1	1	1	1
8	Collar	S.S	423416-01	1	1	1	1	1
9	Cover – Reservoir	ABS	208126-02	1	1	1	1	1
10	Float Switch	TW-1221-101	435490-01	1	1	1	1	1
11	Hose - Water Supply	EVA	425289-01	1	1	1	1	1
12	Cover – Reservoir Inlet	SI.R	415094-01	1	1	1	1	1
13	Hose - Water Supply	EPDM	428615-05	1	1	1	1	1
14	Pipe – Drain	S.S	425292G01	1	1	1	1	1
15	Cap – Drain	Brass	425293-01	1	1	1	1	1
16	Packing – Drain	Sy.R	425294-01	1	1	1	1	1
17	Clamp	MH-30N	426142-04	2	2	2	2	2
18	Clamp	SK-17	435934-05	1	1	1	1	1
19	Clamp	SK-18.3	435934-06	1	1	1	1	1
20	Tie	CV-150	7920-0003	3	3	3	3	3
21	Clamp	SK-25	435934-07	1	1	1	1	1

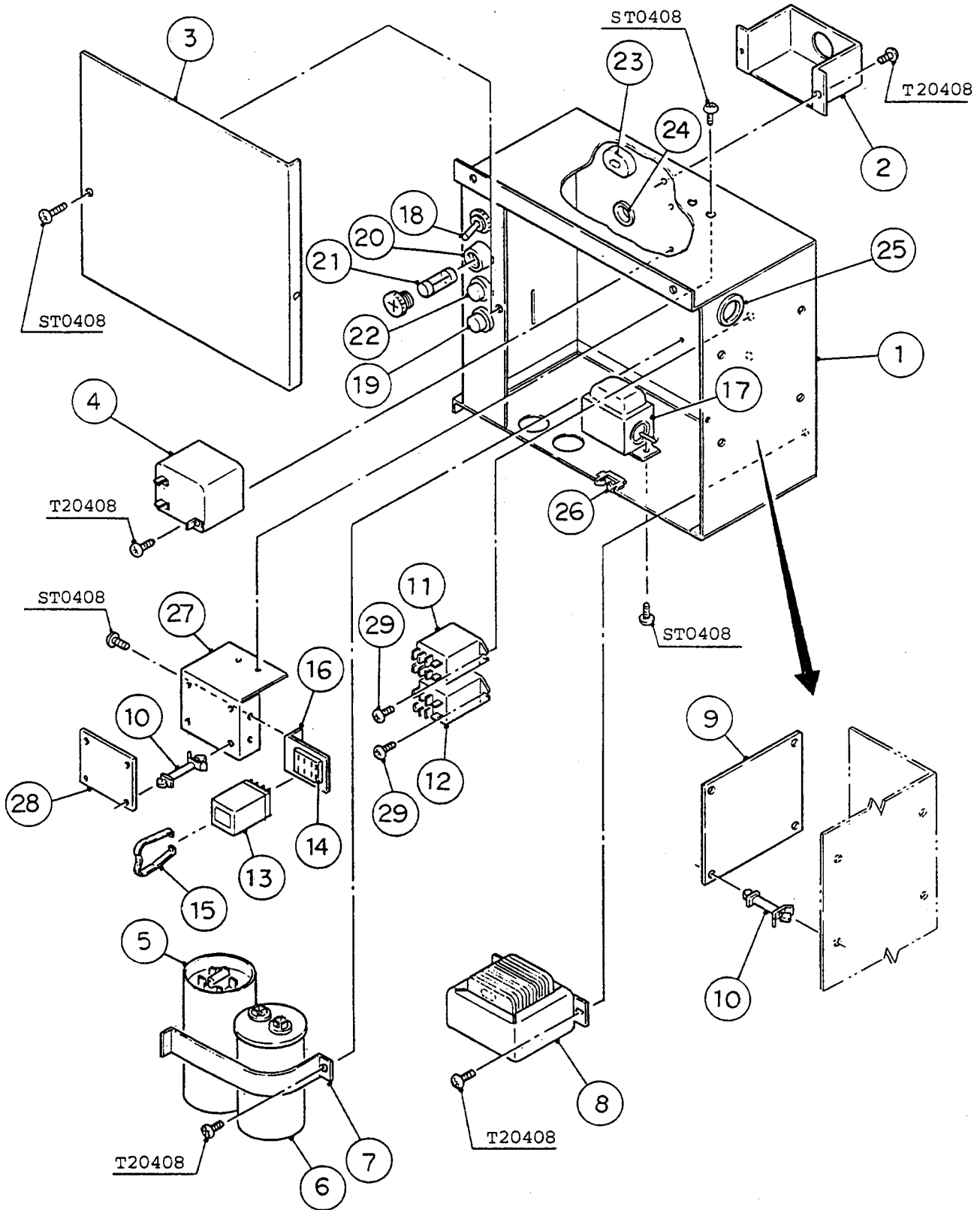

MODEL		TITLE						
F-1100MWA		E. CONTROL BOX ASSY						
INDEX NO.	DESCRIPTION	MATERIAL OR MODEL NUMBER	PART NUMBER	REQ'D NUMBER				
				K-1	A-0	B-0	C-1	C-2
1	Control Box	G.S	315746G08	1	1	1	1	1
2	Cover - Connector	G.S	425302-01	1	1	1	1	1
3	Cover - Control Box	G.S	425301-01	1	1	1	1	1
4	Starter	040-0001-26	434172-01	1	1	1	1	1
5	Start Capacitor	014-0008-78	434171-02	1	1	1	1	1
6	Run Capacitor	014-0037-09	434170-01	1	1	1	1	-
			434170-05					1
7	Strap - Capacitor	G.S	431394-03	1	1	1	1	-
			431394-01					1
8	Transformer	TR5268	2U0041-01	1	1	1	1	1
9	Timer Board	H2AA144C01	437305-01	1	1	1	1	1
10	Board Support	KGLS-6S	414929-01	8	8	8	8	8
11	Re lay	LY1F	418271-04	1	1	1	1	1
12	Re lay	LY2ZF	406132-06	1	1	1	1	1
13	Keep Relay	MY2K-HO	418524-03	1	1	1	1	1
14	Socket - Relay	PY-14	408328-02	1	1	1	1	1
15	Clamp - Relay	PYC-P	411353-01	1	1	1	1	1
16	Bracket - Relay	G.S	425300-01	1	1	1	1	1
17	Thermostat	A10-9756	420465-01	1	1	1	1	1
18	Toggle Switch	S-821	438030-01	1	1	1	1	1
19	Push Button Switch	SB-4011N/OT3959	420466-01	1	1	1	1	1
20	Fuse Holder	FH032	424288-01	1	1	1	1	1
21	Fuse	FGAO-2	420468-03	1	1	1	1	1
22	Over load - Gear Motor	W58xBIA4A-2	425201-01	1	1	1	1	1
23	Bushing	SR-6N3-4	420472-04	1	1	1	1	1
24	Bushing	SB-625-8	420470-01	1	1	1	1	1
25	Bushing	SB-750-10	420470-05	1	1	1	1	1
26	Edge Saddle	EDS-1	421552-01	1	1	1	1	1
27	Beeper Bracket	G.S	323312-01	1	1	1	1	1
28	Beeper	-	435937-01	1	1	1	1	1
29	Tapping Screw	3x8	431415-01	4	4	4	4	4

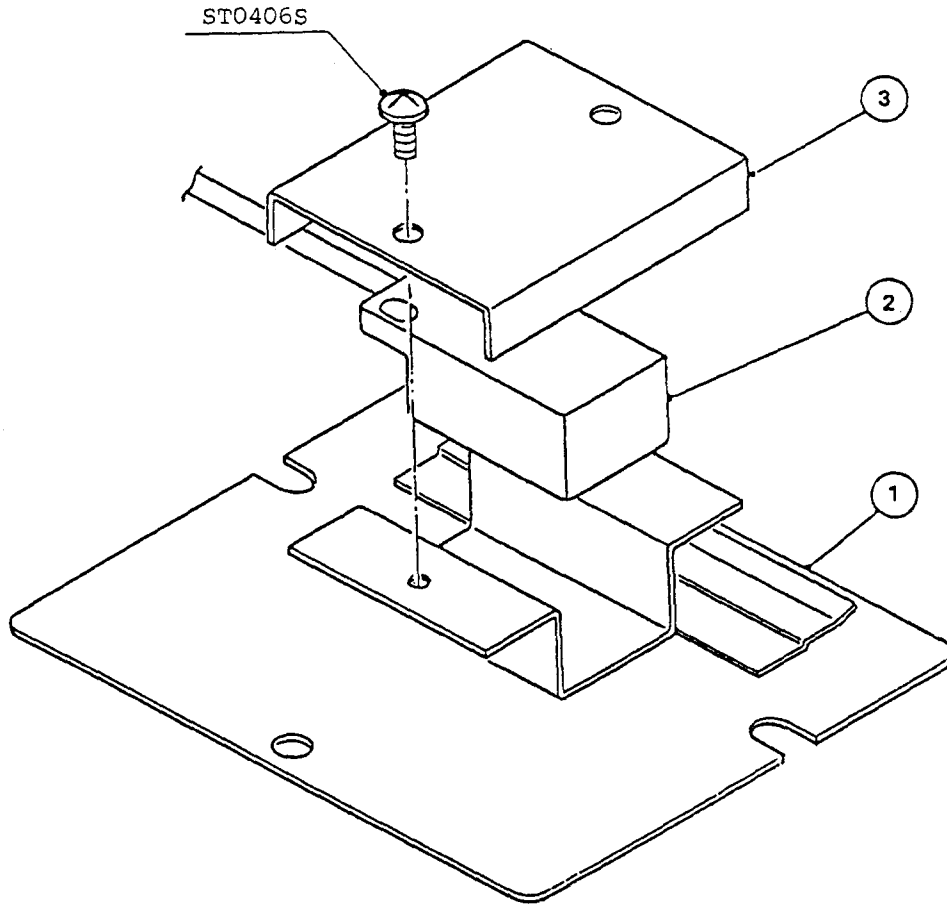

MODEL		TITLE						
F-1100MWA		F. BIN SWITCH ASSY						
INDEX NO.	DESCRIPTION	MATERIAL OR MODEL NUMBER	PART NUMBER	REQ'D NUMBER				
				K-1	A-0	B-0	C-1	C-2
1	Bracket - Switch	S.S	317648G01	1	1	1	1	1
2	Proximity Switch - Bin Control	RS-601	427223-01	1	1	1	1	1
3	Bracket - Proximity Switch	S.S	427158-01	1	1	1	1	1

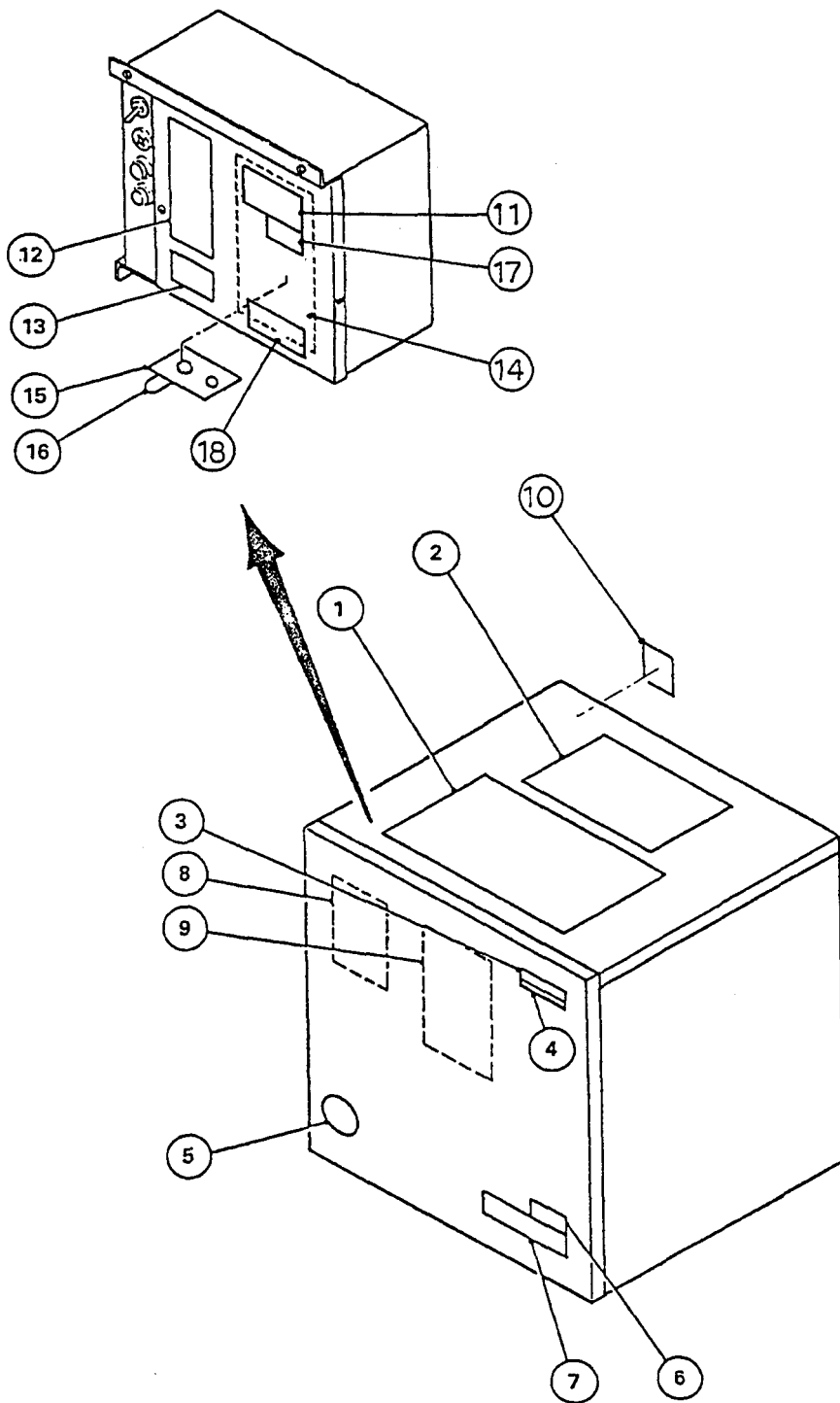

MODEL F-1100MWA		TITLE G. LABEL LOCATION						
INDEX NO.	DESCRIPTION	MATERIAL OR MODEL NUMBER	PART NUMBER	REQ'D NUMBER				
				K-1	A-0	B-0	C-1	C-2
1	Instruction Sheet - Inst. Ope.	Paper	208144-01	1	1	1	1	1
2	Instruction Sheet - Bin Inst.	Paper	208145-01	1	1	1	1	1
3	Emblem (L) - HOSHIZAKI	ABS	418634G01	1	1	1	1	1
4	Label - Model Number	PETP Film	435985-17	1	1	1	1	1
5	Label - Penguin	PETP Film	410994-01	1	1	1	1	1
6	Label - Warning Caution Label (F)	PVC Film	425323-01 439146-01	x1 o1	1	1	1	1
7	Label - Operation, Spout Cont. Instruction Label	PETP Film	425325-01 443470-01	x1 o1	1	1	1	1
8	Label - Operation	PVC Film	315758-01	1	1	1	1	1
9	Label - Cleaning	PVC Film	214783-01	1	1	1	1	1
10	Nameplate	PES Film	438061-01	1	1	1	1	1
11	Rating Label	PES Film	438064-01	1	1	1	1	1
12	Label - Control	PETP Film	438059-01	1	1	1	1	1
13	Label - Danger Caution Label (C)	PVC Film	425322-01 439143-01	x1 o1	1	1	1	1
14	Wiring Label	PVC Film	324881-01	1	1	1	1	1
15	Label - Bin Thermostat	PETP Film	435984-01	1	1	1	1	1
16	Label - Factory Adjusted	PETP Film	419404-01	1	1	1	1	1
17	Label - R502	PES Film	4A0026-01	1	1	1	1	1
18	Warning Label	PVC Film	435955-01	1	1	1	1	1

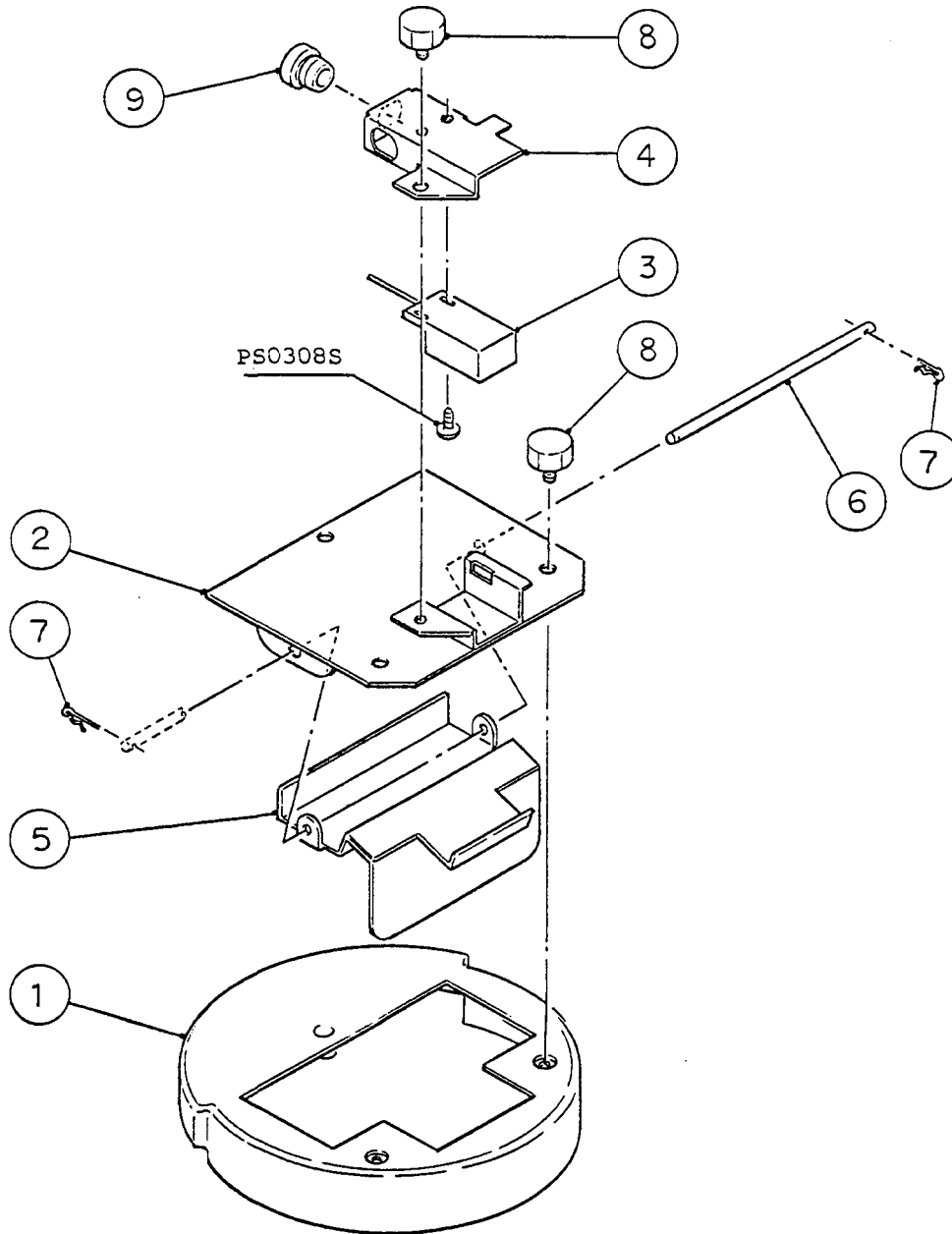

MODEL		TITLE						
F-1100MWA		H. SPOUT CONTROL ASSY						
INDEX NO.	DESCRIPTION	MATERIAL OR MODEL NUMBER	PART NUMBER	REQ'D NUMBER				
				K-1	A-0	B-0	C-1	C-2
1	Cover - Chute	ABS	214796G01	1	1	1	1	1
2	Spout Cover	S.S	325070G01	1	1	1	1	1
3	Proximity Switch	RS-601	427223-01	1	1	1	1	1
4	Bracket - Proximity Switch	S.S	324106-01	1	1	1	1	1
5	Paddle	S.S	323310G01	1	1	1	1	1
6	Axle	S.S	435873-01	1	1	1	1	1
7	Snap Pin	S.S, SSP-4	715S-0004	2	2	2	2	2
8	Thumbscrew	ABS, S.S	415949G04	3	3	3	3	3
9	Bushing	SR-5KN-4	420472-06	1	1	1	1	1

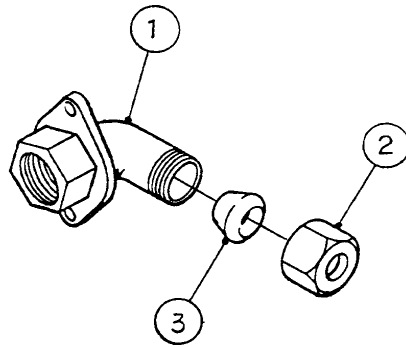

MODEL		TITLE						
F-1100MWA		J. FITTING (U) ASSY						
INDEX NO.	DESCRIPTION	MATERIAL OR MODEL NUMBER	PART NUMBER	REQ'D NUMBER				
				K-1	A-0	B-0	C-1	C-2
1	Fitting (M)	Brass Casting	310980-01	1	1	1	1	1
2	Nut (A)	Brass	415713-01	1	1	1	1	1
3	Packing (A)	Sy.R	415715-01	1	1	1	1	1

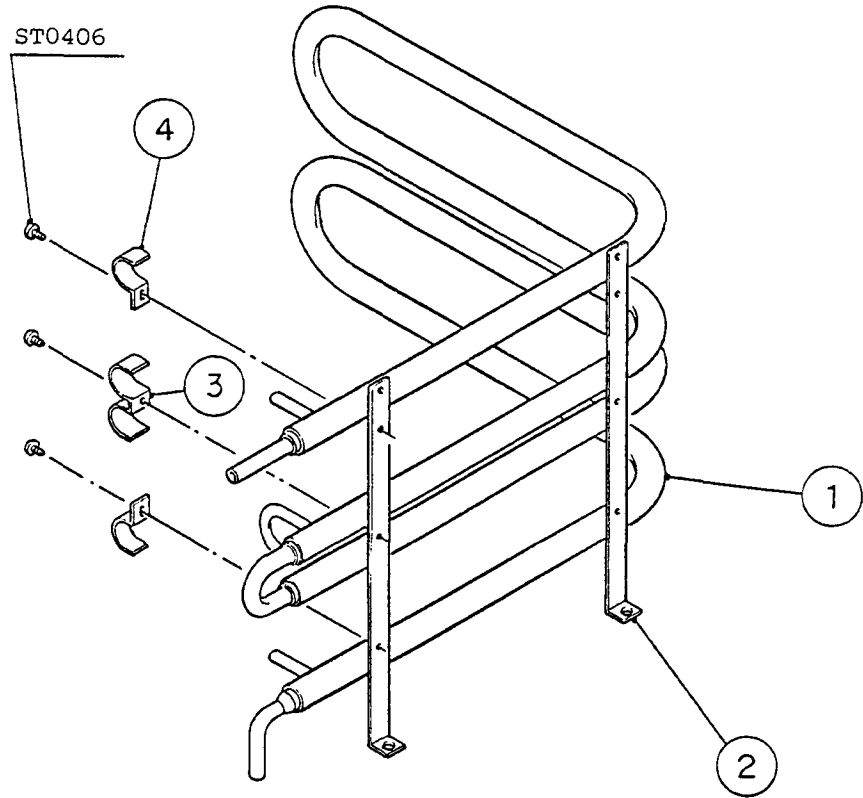

MODEL F-1100MWA		TITLE K. CONDENSER - WATER-COOLED						
INDEX NO.	DESCRIPTION	MATERIAL OR MODEL NUMBER	PART NUMBER	REQ'D NUMBER				
				K-1	A-0	B-0	C-1	C-2
1	Condenser - Water-cooled	-	214692G01	1	1	1	1	1
2	Bracket - Condenser	G.S	425573-01	2	2	2	2	2
3	Strap - Condenser	G.S	422985-01	2	2	2	2	2
4	Strap - Condenser	G.S	4H0622-01	4	4	4	4	4

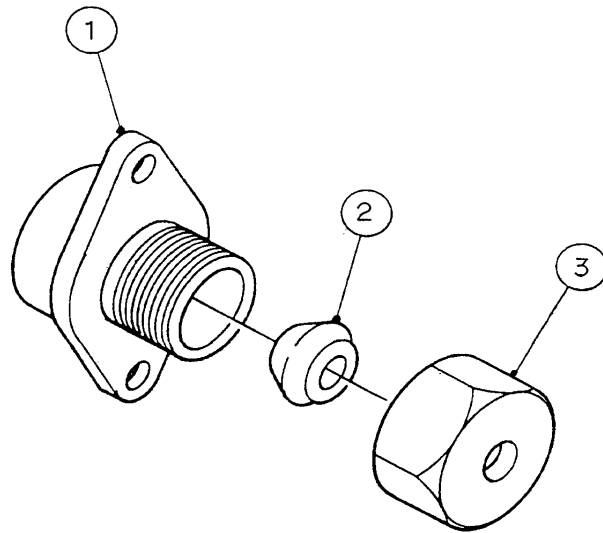

MODEL
F-1100MWA

TITLE
L. FITTING (K) ASSY

INDEX NO.	DESCRIPTION	MATERIAL OR MODEL NUMBER	PART NUMBER	REQ'D NUMBER				
				K-1	A-0	B-0	C-1	C-2
1	Fitting (K)	Brass Casting	310978-01	1	1	1	1	1
2	Packing (C)	Sy.R	415715-02	1	1	1	1	1
3	Nut (B)	Brass	415713-02	1	1	1	1	1

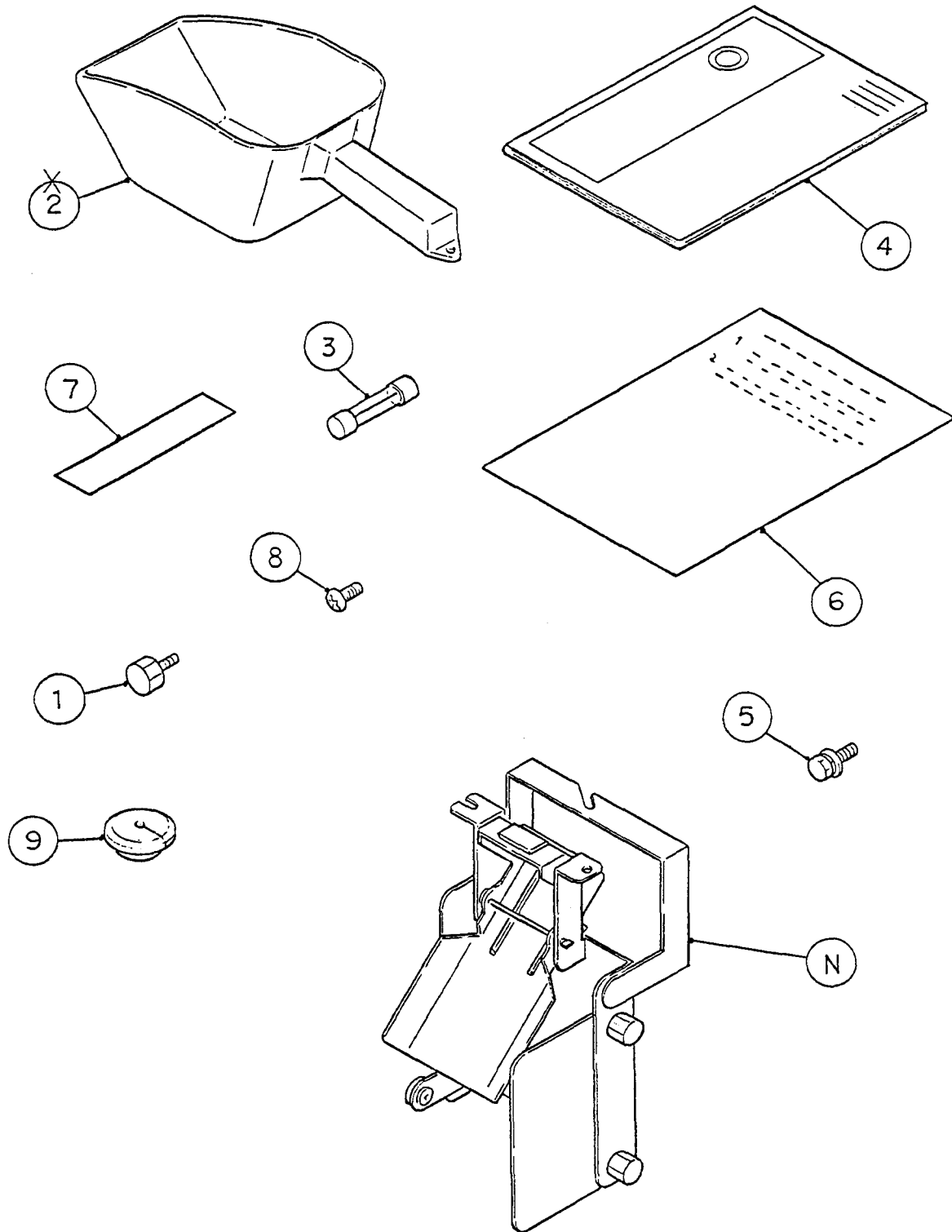

MODEL		TITLE						
F-1100MWA		M. ACCESSORIES						
INDEX NO.	DESCRIPTION	MATERIAL OR MODEL NUMBER	PART NUMBER	REQ'D NUMBER				
				K-1	A-0	B-0	C-1	C-2
N	BIN CONTROL ASSY	-	325073A01	1	1	1	1	1
1	Thumbscrew	S.S	415949G04	3	3	3	3	3
2	Scoop	S.S, SSP-4	208185-01	1	1	1	x1	
3	Fuse	S.S, ABS	420468-03	1	1	1	1	1
4	Instruction Manual	Paper	91U2AF10A	1	1	1	1	1
5	Bolt and Washer Assy SW	S.S, M8x16	-	2	2	2	2	2
6	Instruction Sheet – Bin Control	Paper	32351-01B	1	1	1	1	1
7	Instruction Sheet - Fastener	Paper	427122-01	1	1	1	1	1
8	Truss Head Machine Screw	S.S, M4x30	-	2	2	2	2	2
9	Bushing - Capillary Tube	EP Rubber	425307-01	1	1	1	1	1

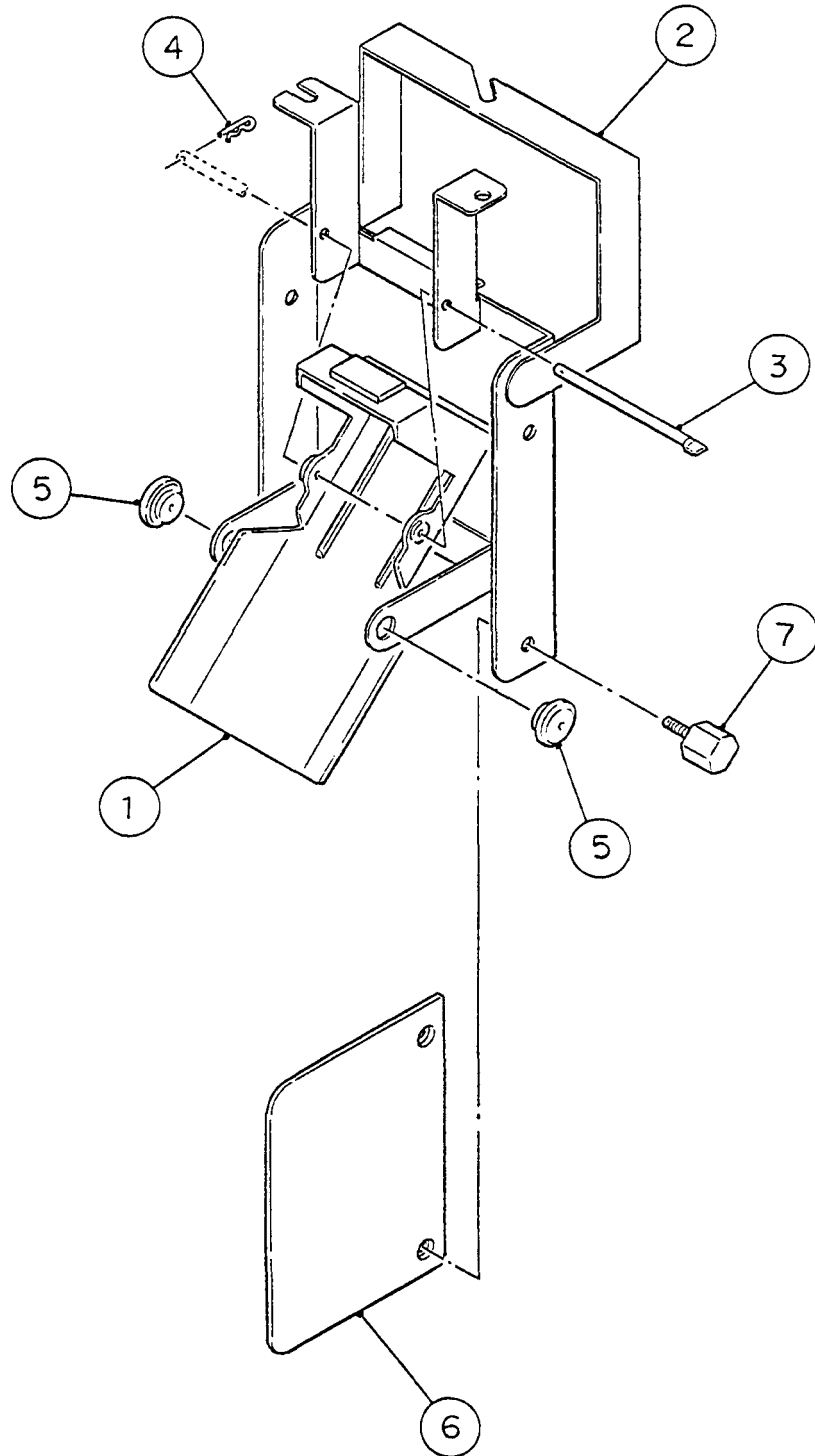

MODEL		TITLE						
F-1100MWA		N. BIN CONTROL ASSY						
INDEX NO.	DESCRIPTION	MATERIAL OR MODEL NUMBER	PART NUMBER	REQ'D NUMBER				
				K-1	A-0	B-0	C-1	C-2
1	Actuator - Switch	ABS, S.S	209168G01	1	1	1	1	1
2	Bin Control Bracket	S.S	325072G01	1	1	1	1	1
3	Shaft	S.S	412337-03	1	1	1	1	1
4	Snap Pin	S.S, SSP-4	715S-0004	1	1	1	1	1
5	Bushing - Capillary Tube	PC	425307-01	2	2	2	2	2
6	Paddle Cover	ABS, S.S	438297G01	1	1	1	1	1
7	Thumbscrew		415949G01	2	2	2	2	2