



**HOSHIZAKI**

**MODULAR FLAKER**

**MODEL**

**F-1101 ASU**

**F-1101 ASU-1**

**PARTS LIST**

---

ISSUED: JUL.1,1985

---

REVISED: APR. 19,1989

---

PRINTED: DEC. 10, 1994

---

ITEM NO: 71039

---

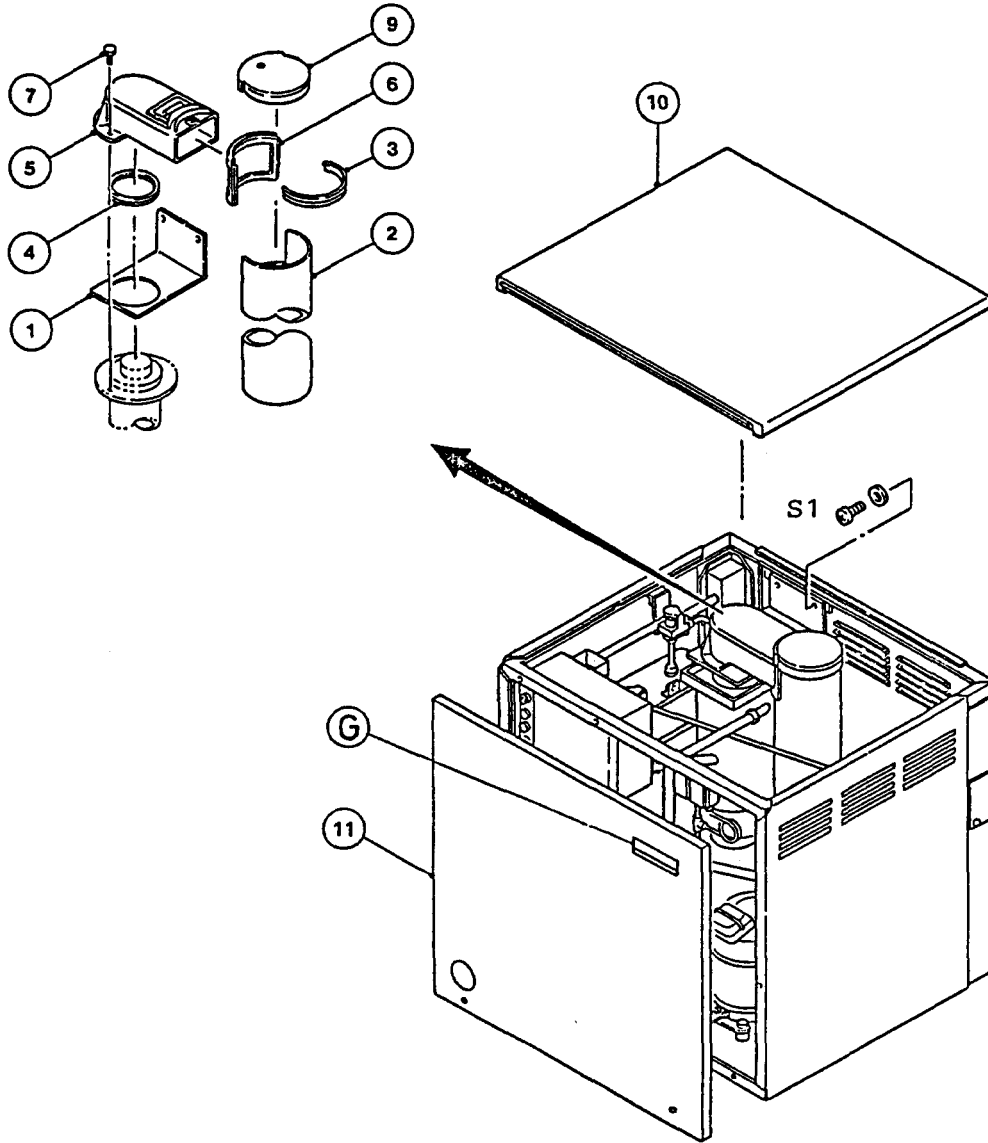

FASTENER

S1 - TRUSS HEAD MACHINE SCREW, STAINLESS, M5x12

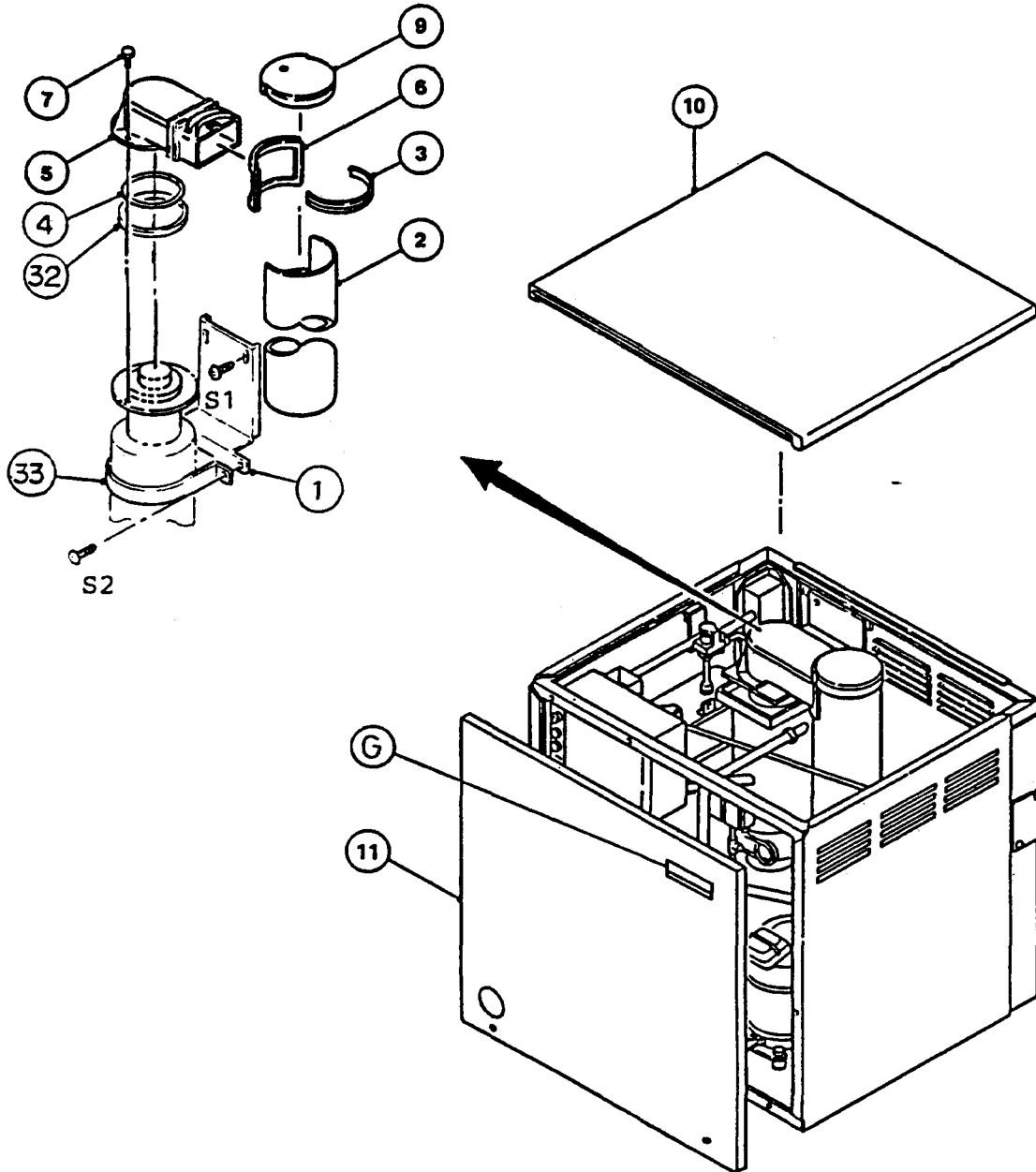

FASTENER

S1 - TRUSS HEAD MACHINE SCREW, STAINLESS, M5x12

S2 - TRUSS HEAD MACHINE SCREW, M4x8

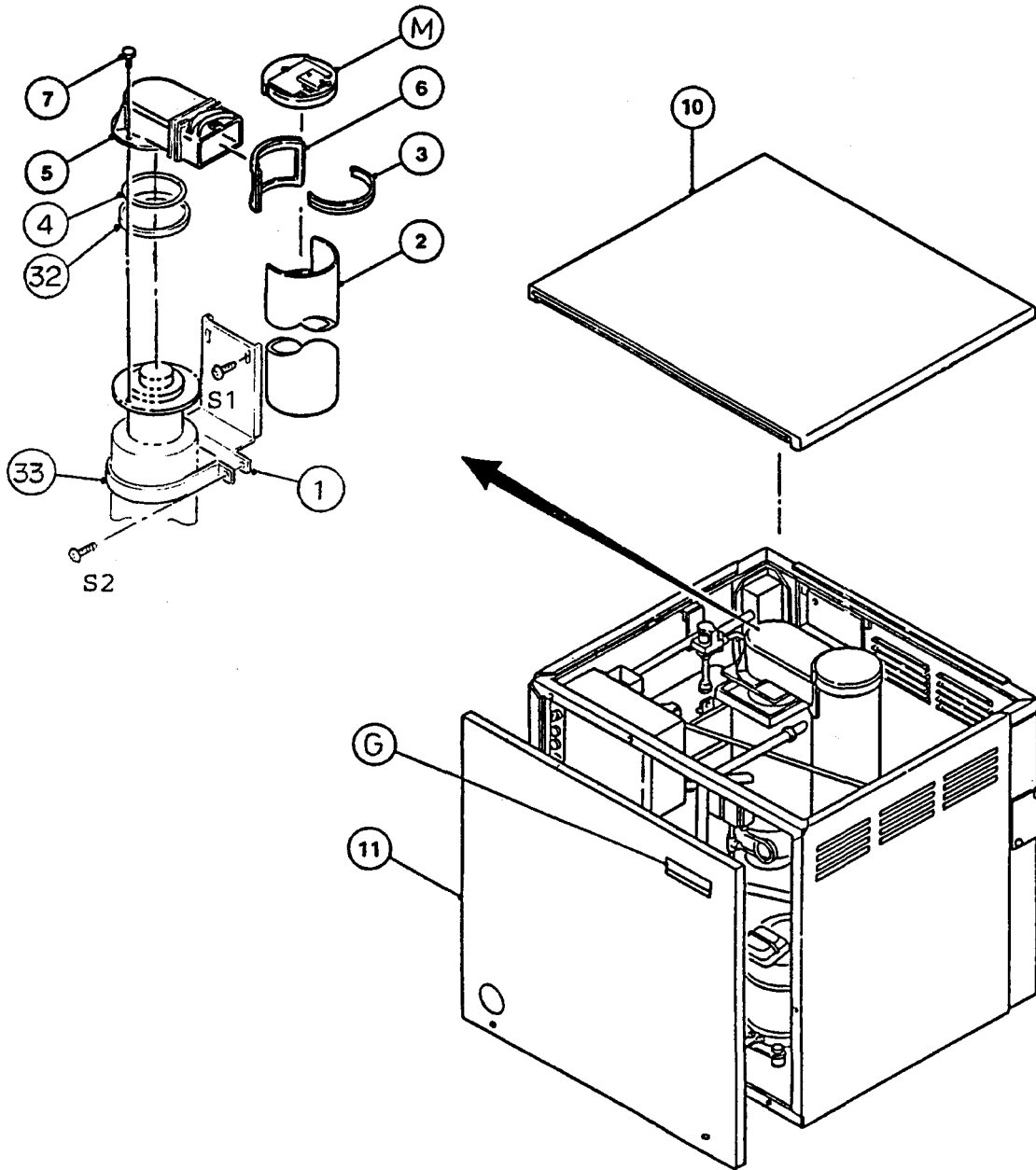

FASTENER

- S1 - TRUSS HEAD MACHINE SCREW, STAINLESS, M5x12
- S2 - TRUSS HEAD MACHINE SCREW. M4x8

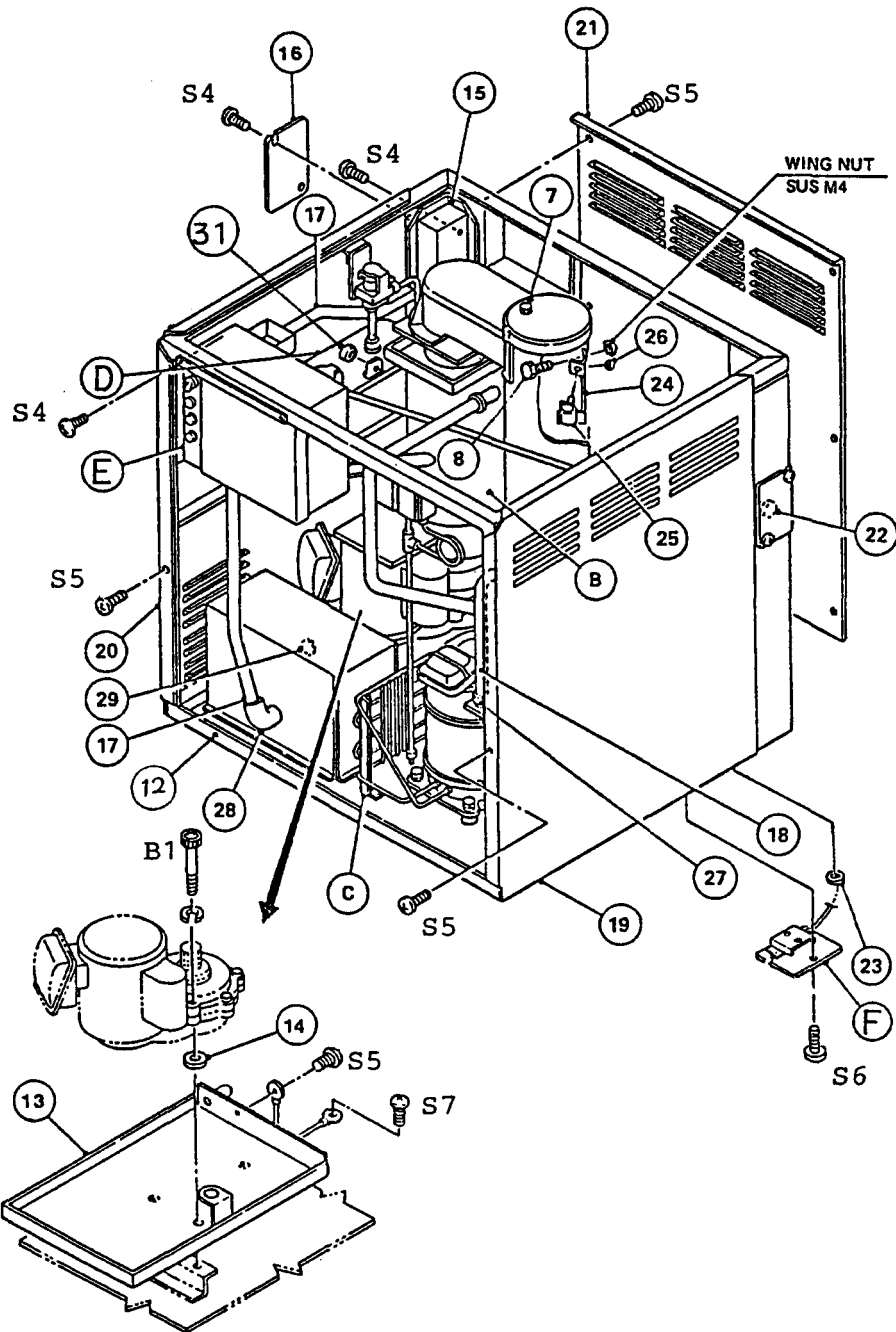

FASTENER

- S4 - TRUSS HEAD MACHINE SCREW, M4x8
- S5 - TRUSS HEAD MACHINE SCREW, STAINLESS, M4x6
- S6 - TRUSS HEAD MACHINE SCREW, STAINLESS, M4x8
- S7 - TRUSS HEAD MACHINE SCREW, M4x6
- B1 - HEXAGON SOCKET CAP BOLT, STAINLESS, M8x90

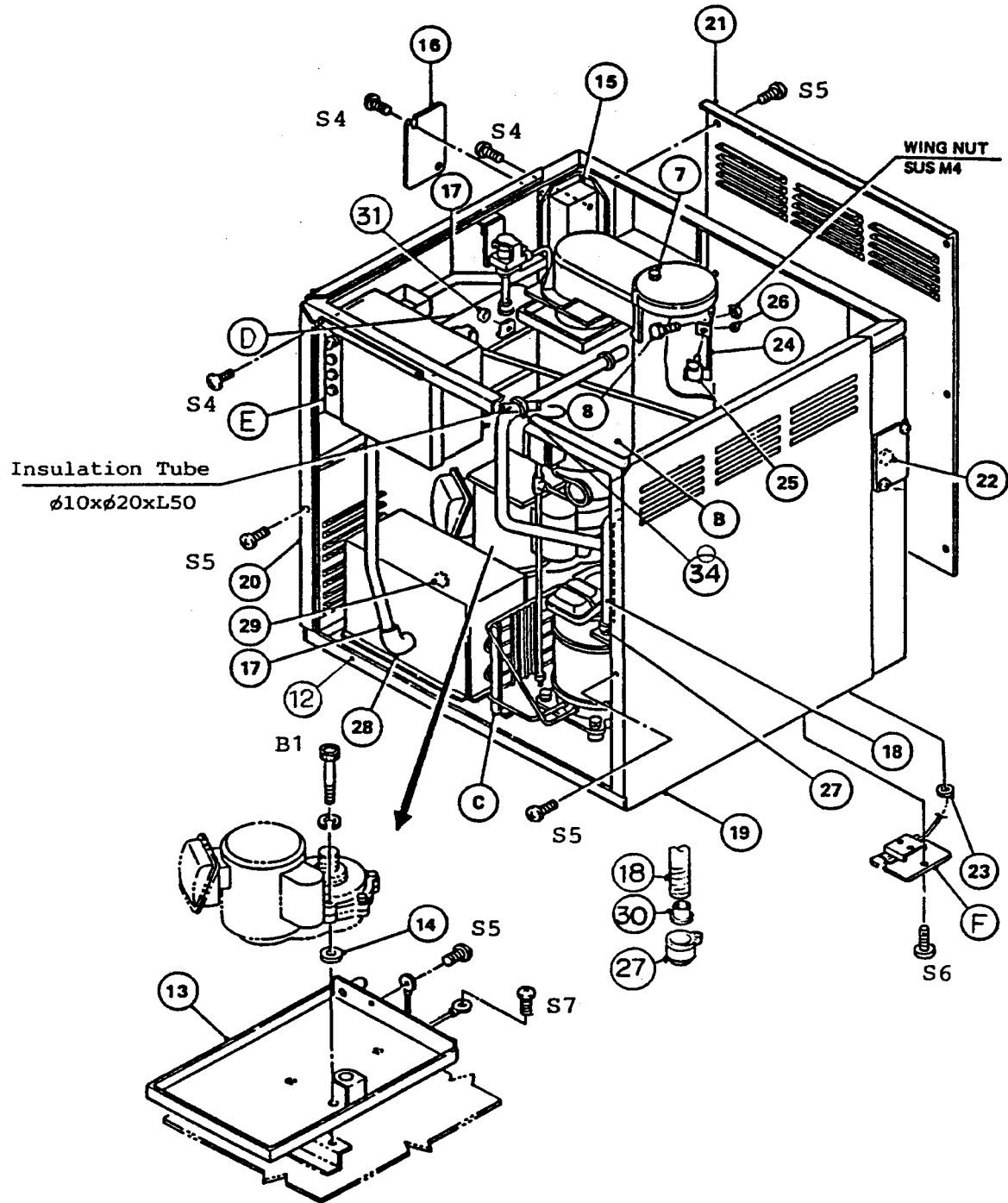

FASTENER

- S4 - TRUSS HEAD MACHINE SCREW. M4x8
- S5 - TRUSS HEAD MACHINE SCREW, STAINLESS, M4x6
- S6 - TRUSS HEAD MACHINE SCREW, STAINLESS. M4x8
- S7 - TRUSS HEAD MACHINE SCREW, M4x6
- B1 - HEXAGON SOCKET CAP BOLT, STAINLESS. M8x90

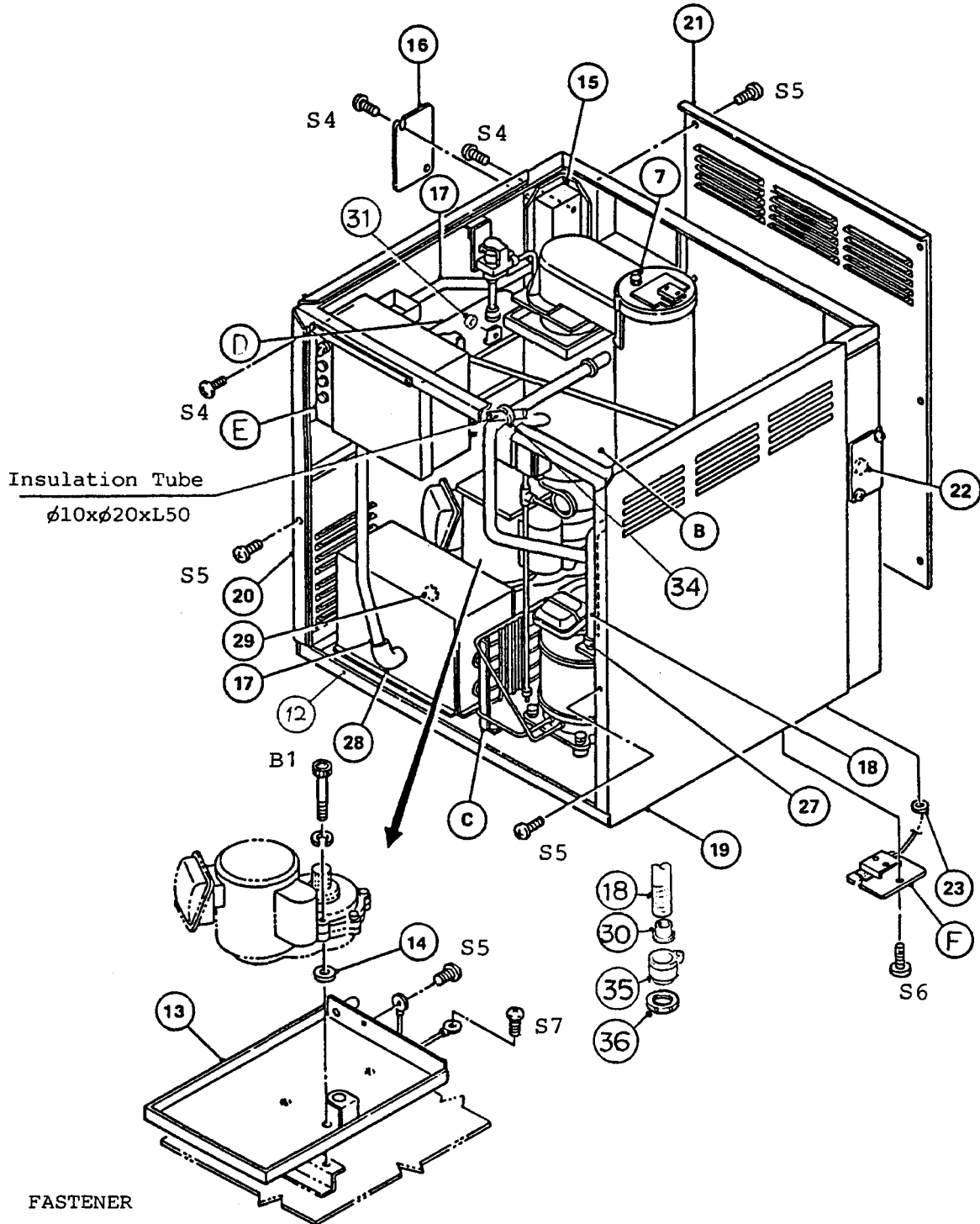

- S4 - TRUSS HEAD MACHINE SCREW, M4x8
- S5 - TRUSS HEAD MACHINE SCREW, STAINLESS, M4x6
- S6 - TRUSS HEAD MACHINE SCREW, STAINLESS, M4x8
- S7 - TRUSS HEAD MACHINE SCREW, M4x6
- B1 - HEXAGON SOCKET CAP BOLT, STAINLESS, M8x90

MODEL F-1101ASU, ASU-1		TITLE A. GENERAL ASSEMBLY			REQ'D NUMBER				
INDEX NO.	DESCRIPTION	MATERIAL OR MODEL NUMBER	PART NUMBER	REQ'D NUMBER					
				E-1	F-1	F-2	G-1	H-1	
B	EVAPORATOR ASSEMBLY	-	208112A04	1	-				
			319958A03		1	1	1	1	
C	REFRIGERATION UNIT	-	103380A01	1	1	1	1	1	
D	WATER CIRCUIT ASSEMBLY	-	103078A02	1	-				
			103078A03		1	1	1	1	
E	CONTROL BOX ASSEMBLY	-	208212A03	1	1	-			
			208212A04			1	1	1	
F	BIN SWITCH ASSEMBLY	-	317649A01	1	1	1	1	1	
G	LABEL LOCATION	-	208420A06	1	1	1	1	-	
			208420A07					1	
1	Bracket - Evaporator	S.S	425251-01	1	1	1	-		
		G.S	431735-01				1	1	
2	Chute	PE	318613-01	1	1	1	-		
			320555-01				1	1	
3	Packing - Chute	EPDM	425255-01	1	1	1	1	1	
4	Packing - Cylinder "O" Ring	EPDM	427151-03	1	1	1	-		
		G95	7616-G095				1	1	
5	Spout	ABS	103382G01	1	1	1	-		
		PC	103932G01				1	1	
6	Packing - Spout	EPDM	315722-01	1	1	1	1	1	
7	Thumbscrew	S.S, ABS	415949G03	4	4	4	4	4	
8	Thumbscrew	S.S, ABS	415949G04	2	2	2	2	2	
9	Cover - Chute	ABS	209817G01	1	1	1	1	1	
10	Top Panel	S.S	315750G01	1	1	1	1	1	
11	Front Panel	S.S	315937-01	1	1	1	-		
			315937-02				1	1	
12	Frame	G.S	315778G05	1	1	1	1	1	
13	Drip Pan	S.S	317168G01	1	1	1	1	1	
14	Washer	PVC	422916-01	3	3	3	3	3	
15	Junction Box	No. 6001	421587-01	2	2	2	2	2	
16	Cover - Junction Box	G.S	420594-01	2	2	2	2	2	
17	Conduit	-	429313-02	2	2	2	2	2	
18	Conduit	-	429313-03	1	1	1	1	1	
19	Side Panel (Right)	S.S	315934G01	1	1	1	1	1	



MODEL F-1101ASU-1		TITLE A. GENERAL ASSEMBLY						
INDEX NO.	DESCRIPTION	MATERIAL OR MODEL NUMBER	PART NUMBER	REQ'D NUMBER				
				J-1	J-2			
B	EVAPORATOR ASSEMBLY	-	319958A03	1	1			
C	REFRIGERATION UNIT	-	103380A01	1	-			
			103380A02		1			
D	HATER CIRCUIT ASSEMBLY	-	103078A03	1	1			
E	CONTROL BOX ASSEMBLY	-	213117A03	1	1			
F	BIN SWITCH ASSEMBLY	-	317649A01	1	1			
G	LABEL LOCATION	-	213149A03	1	1			
M	SPOUT CONTROL ASSEMBLY	-	323313A01	1	1			
1	Bracket - Evaporator	G.S	431735-01	1	1			
2	Chute	PE	315723-01	1	1			
3	Packing - Chute	EPDM	425255-01	1	1			
4	"0" Ring	G95	7616-G095	1	1			
5	Spout	PC	103932G01	1	1			
6	Packing - Spout	EPDM	315722-01	1	1			
7	Thumbscrew	S.S. ABS	415949G03	4	4			
8	Thumbscrew	S.S, ABS	415949G04	-				
9	Cover - Chute	ABS	209817G01	-				
10	Top Panel	S.S	315750G01	1	1			
11	Front Panel	S.S	315937-02	1	1			
12	Frame	G.S	315778G08	1	1			
13	Drip Pan	S.S	317168G01	1	1			
14	Hasher	PVC	422916-01	3	3			
15	Junction Box	No. 6001	421587-01	2	2			
16	Cover - Junction Box	G.S	420594-01	2	2			
17	Conduit	-	429313-02	2	2			
18	Conduit	-	429313-03	1	1			
19	Side Panel (Right)	S.S	315934G01	1	1			

MODEL F-1101ASU, ASU-1		TITLE A. GENERAL ASSEMBLY						
INDEX NO.	DESCRIPTION	MATERIAL OR MODEL NUMBER	PART NUMBER	REQ'D NUMBER				
				E-1	F-1	F-2	G-1	H-1
20	Side Panel (Left)	S.S	315935G02	1	1	1	1	1
21	Rear Panel	S.S	315936-01	1	1	1	1	1
22	Bushing	SR-4K-4	<a href="#">420470-01</a>	1	1	1	1	1
23	Bushing	SB-437-5	<a href="#">420470-07</a>	1	1	1	1	1
24	Bracket - Thermostat	S.S	318612-01	1	1	1	1	1
25	Clip	PA No.96	429285-01	2	2	2	2	2
26	Bushing - Capillary Tube	EPDM	<a href="#">425307-01</a>	1	1	1	1	1
27	Fitting - Conduit, Straight	No. 13-16	425316-01	5	5	5	5	5
28	Fitting - Conduit, Elbow	No. 13-16	425317-01	1	1	1	1	1
29	Bushing	SB-625-8	<a href="#">420470-01</a>	1	1	1	1	1
30	Collar	Steel	430335-01		6	6	6	6
31	Bushing	SR-30-1	<a href="#">420472-03</a>	1	1	1	1	1
32	Ring	PA	<a href="#">431736-01</a>				1	1
33	Strap	G.S	<a href="#">431737-01</a>				1	1
34	Tie	CV-150	7920-0003					1

MODEL F-1101ASU-1		TITLE A. GENERAL ASSEMBLY						
INDEX NO.	DESCRIPTION	MATERIAL OR MODEL NUMBER	PART NUMBER	REQ'D NUMBER				
				J-1				
20	Side Panel (Left)	S.S	315935G02	1				
21	Rear Panel	S.S	315936-01	1				
22	Bushing	SR-4K-4	420470-01	1				
23	Bushing	SB-437-5	420470-07	1				
24	Bracket - Thermostat	S.S	318612-01	-				
25	Clip	PA No. 96	429285-01	-				
26	Bushing - Capillary Tube	EPDM	425307-01	-				
27	Fitting - Conduit, Straight	No. 13-16	425316-01	-				
28	Fitting - Conduit, Elbow	No. 13-16	425317-01	1				
29	Bushing	SB-625-8	420470-01	1				
30	Collar	Steel	430335-01	6				
31	Bushing	SR-30-1	420472-03	1				
32	Ring	PA	431736-01	1				
33	Strap	G.S	431737-01	1				
34	Tie	CV-150	7920-0003	1				
35	Fitting - Conduit	NS-1621	435753-01	5				
36	Nut	t3.6	435753F01	5				

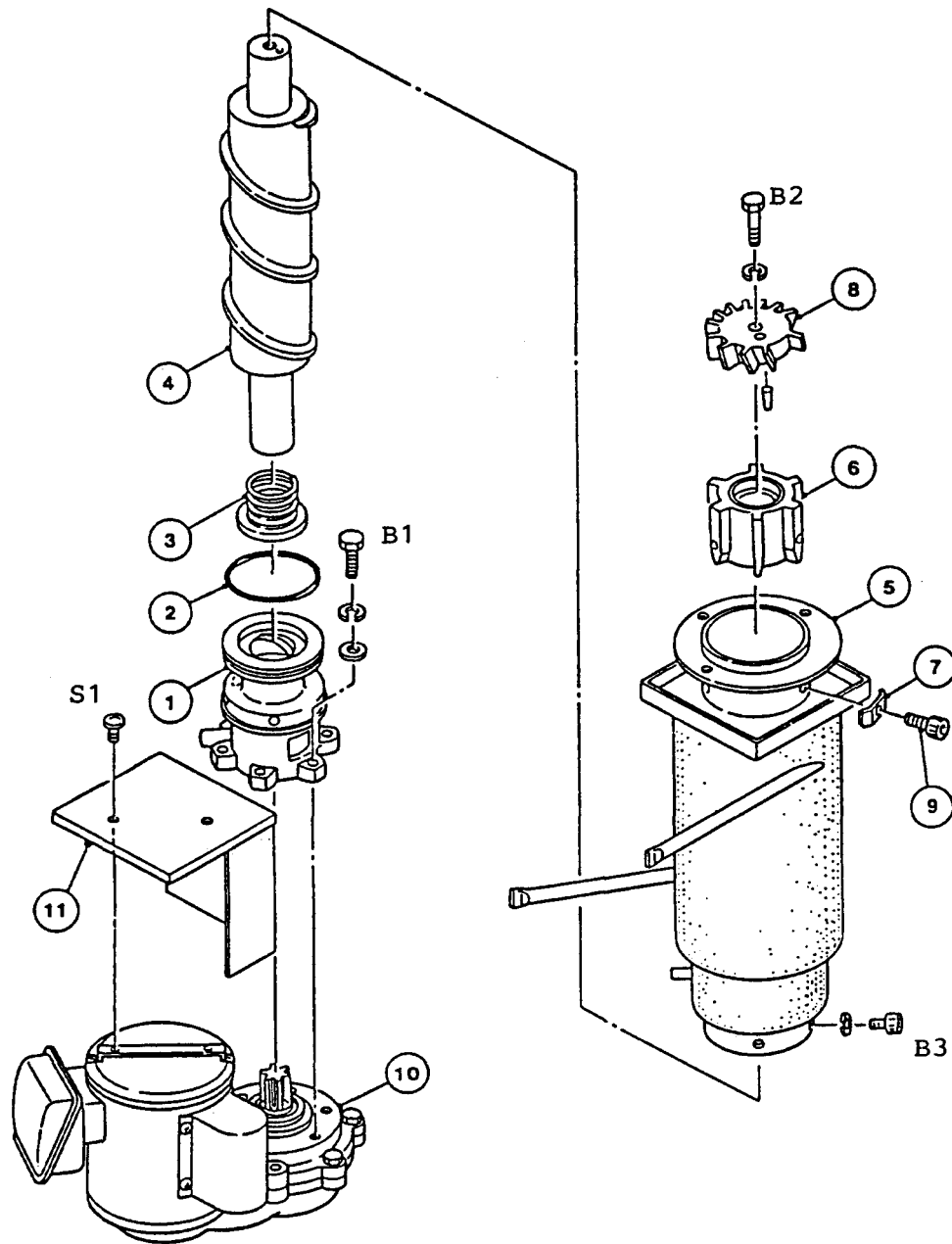

FASTENER

- S1 - TRUSS HEAD MACHINE SCREW, M4x8
- B1 - HEXAGON HEAD BOLT, STAINLESS, M8x30
- B2 - HEXAGON HEAD BOLT, STAINLESS, M10x30
- B3 - HEXAGON SOCKET CAP BOLT, STAINLESS, M10x20

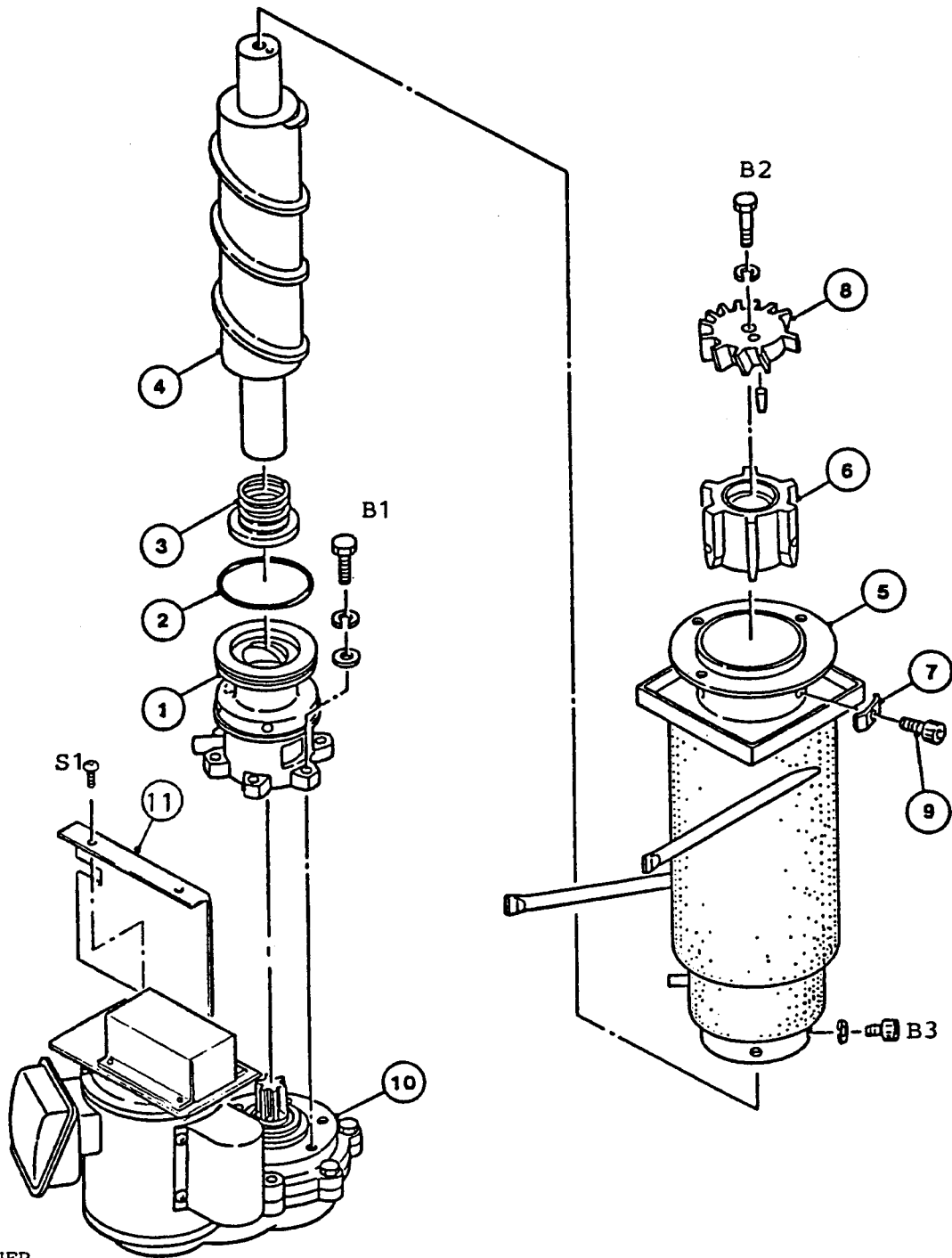

**FASTENER**

- S1 - TRUSS HEAD MACHINE SCREW, M4x8
- B1 - HEXAGON HEAD BOLT, STAINLESS, M8x30
- B2 - HEXAGON HEAD BOLT, STAINLESS, M10x40
- B3 - HEXAGON SOCKET CAP BOLT, STAINLESS, M10x20

MODEL		TITLE						
F-1101ASU, ASU-1		B. EVAPORATOR ASSEMBLY						
INDEX NO.	DESCRIPTION	MATERIAL OR MODEL NUMBER	PART NUMBER	REQ'D NUMBER				
				E-1	F-1	F-2	G-1	H-1
1	Bearing (Lower)	-	315732G02	1	1	1	1	1
2	"O" Ring	G90	7616-G090	1	1	1	1	1
3	Mechanical Seal	HG9A-MN	420692-01	1	1	1	1	-
		HK9A-MN	432493-01					1
4	Auger	S.S	209744G01	1	1	1	-	
			211062G01				1	1
5	Evaporator	-	425273G04	1	1	1	1	1
6	Extruding Head	S.S	208117G02	1	1	1	1	1
7	Washer	S.S	425277-01	3	3	3	3	3
8	Cutter	S.S	315734-01	1	1	1	1	1
9	Socket Head Cap Screw	S.S, M10	429121-02	3	3	3	3	3
10	Gear Motor	MGZ2200UL-160	2U0044-01	1	-			
			432068-01		1	1	1	1
11	Cover - Gear Motor	G.S	315841G01	1	-			
			431532-01		1	1	1	1

MODEL F-1101ASU-1		TITLE B. EVAPOBATOR ASSEMBLY					
INDEX NO.	DESCRIPTION	MATERIAL OR MODEL NUMBER	PART NUMBER	REQ'D NUMBER			
				J-1			
1	Bearing (Lower)	-	315732G02	1			
2	"O" Ring	G90	7616-G090	1			
3	Mechanical Seal	HK9A-MN	432493-01	1			
4	Auger	S.S	211062G01	1			
5	Evaporator	-	425273G04	1			
6	Extruding Head	S.S	208117G02	1			
7	Washer	S.S	425277-01	3			
8	Cutter	S.S	315734-01	1			
9	Socket Head Cap Screw	S.S, M10	429121-02	3			
10	Gear Motor	MGZ2200UL-160	432068-01	1			
11	Cover - Gear Motor	G.S	431532-01	1			

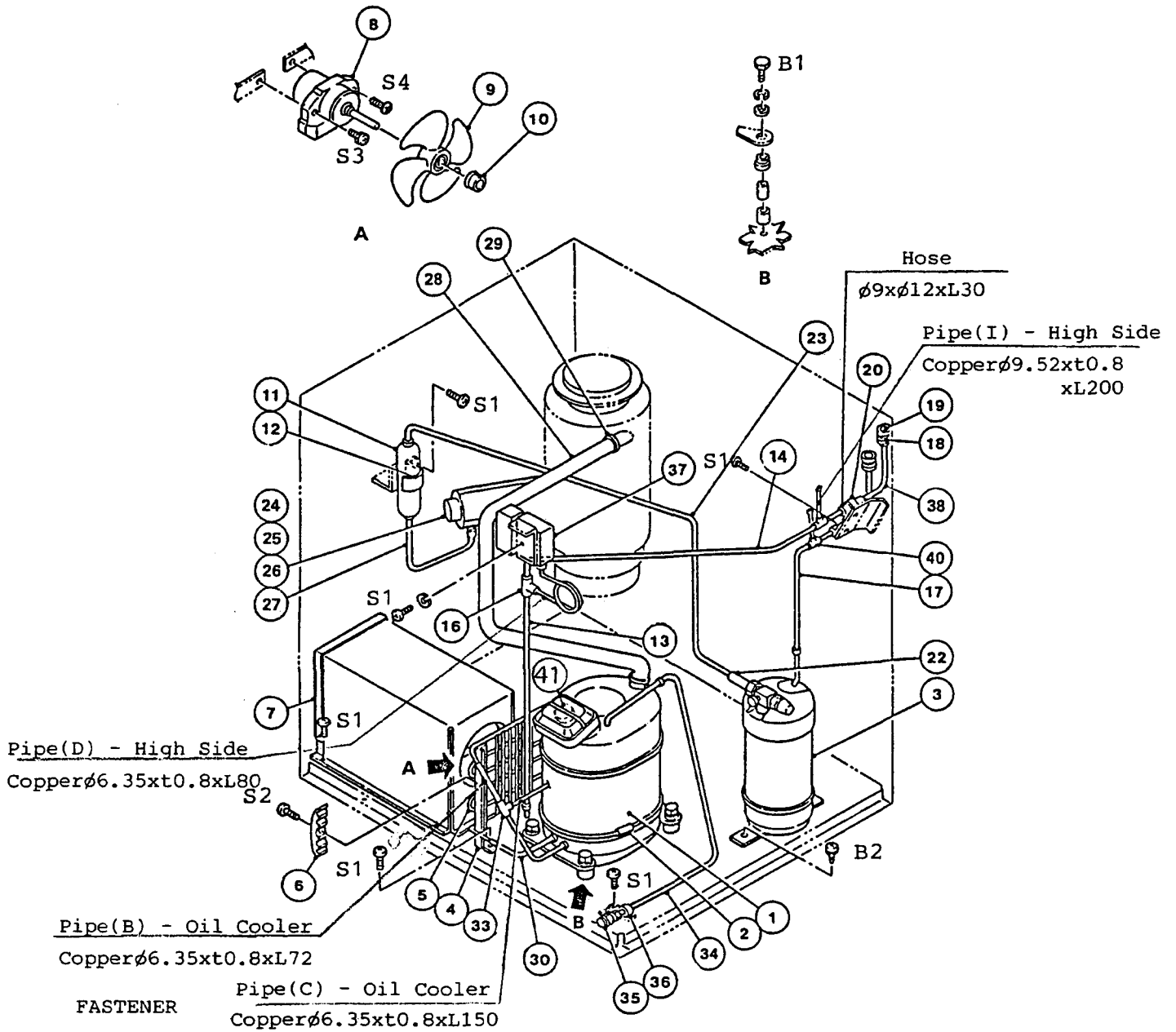



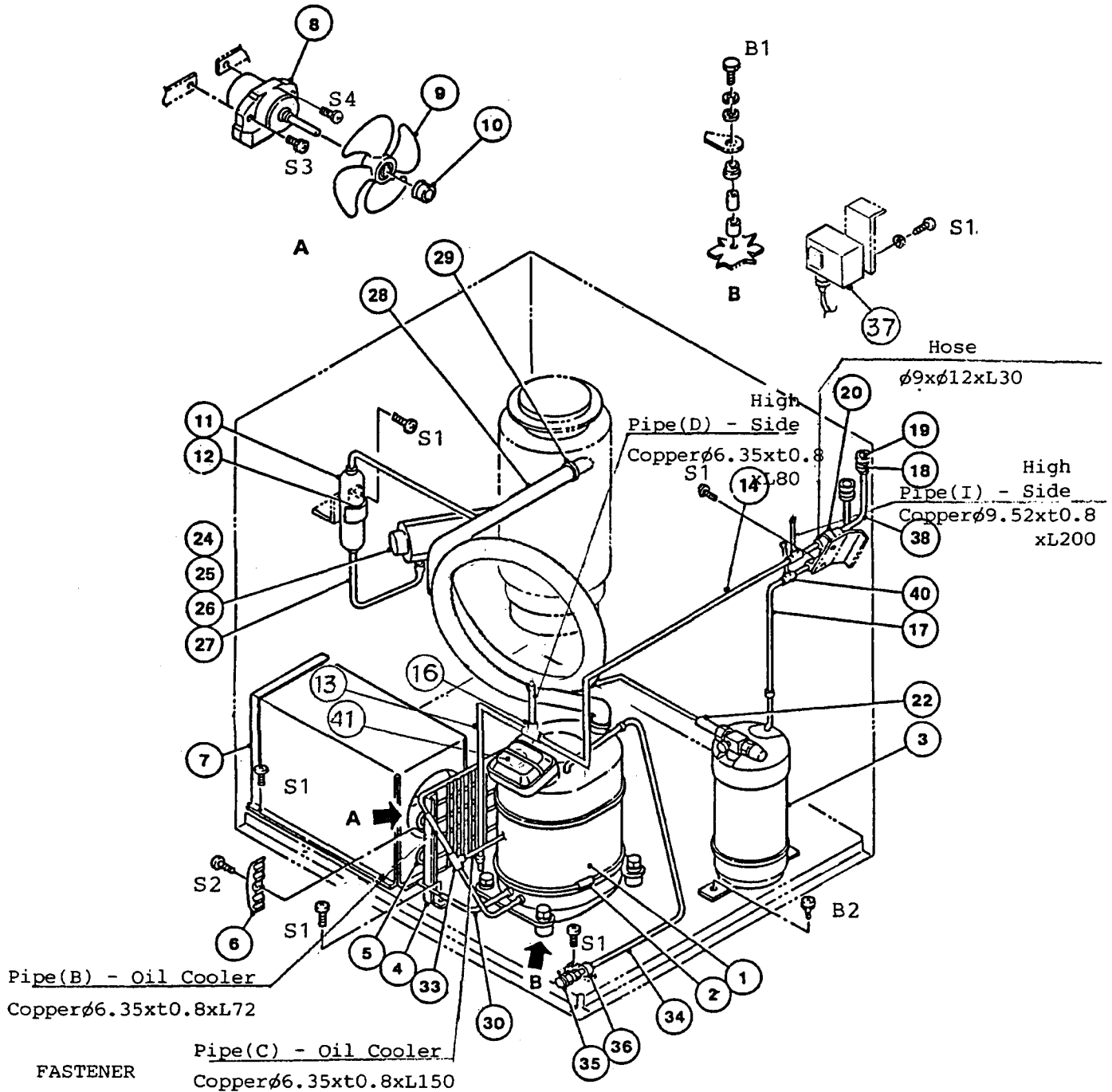

- S1 - TRUSS HEAD MACHINE SCREW, M4x8
- S2 - TRUSS HEAD MACHINE SCREW, M4x12
- S3 - PAN HEAD SCREW AND SPRING WASHER ASSY, STAINLESS, M4x25
- S4 - TRUSS HEAD MACHINE SCREW, STAINLESS, M4x25
- B1 - HEXAGON HEAD BOLT, M8x45
- B2 - HEXAGON BOLT AND SPRING WASHER + PLAIN WASHER ASSY, M6x12

MODEL		TITLE							
F-1101ASU, ASU-1		C. REFRIGERATION UNIT							
INDEX NO.	DESCRIPTION	MATERIAL OR MODEL NUMBER	PART NUMBER	REQ'D NUMBER					
				E-1	F-1	F-2	G-1	H-1	
1	Compressor	KL100TD-3	2U0043-01	1	1	1	1	1	
2	Crankcase Heater	CH5700	425534-01	1	1	1	1	1	
3	Receiver Tank	RT-P-HD	2U0037-02	1	1	1	1	1	
4	Bracket - Condenser	G.S	425518-01	2	2	2	2	2	
5	Condenser - Air-cooled	-	208211G01	1	1	1	1	1	
6	Strap	AC	310606-01	2	2	2	2	2	
7	Shroud	G.S	315927G01	1	1	1	1	1	
8	Fan Motor	MS17ZJF-HJA7	3U0050-01	1	1	1	1	1	
9	Fan Blade	ABS	419547-01	1	1	1	1	1	
10	Fan Ring	S.S	419547P01	1	1	1	1	1	
11	Drier	DYN-2-HD-1	418498-01	1	1	1	1	1	
12	Strap	G.S	425280-01	1	- 1	1	1	1	
13	Pipe (A) - High Side	Copper	425520-01	1	1	1	1	1	
14	Pipe (B) - High Side	Copper	315929-01	1	1	1	1	1	
15	-	-	-	-					
16	Tee	Copper	420041-05	1	1	1	1	1	
17	Pipe (E) - High Side	Copper	425521-01	1	1	1	1	1	
18	Coupling (Male)	5782-6-6	426554-01	2	2	2	2	2	
19	Cap - Shipping	FF9080-06	426554F01	2	2	2	2	2	
20	Strap	G.S	416877-01	3	3	3	3	3	
21	-	-	-	-					
22	Pipe (C2) - High Side	Copper	420599-02	1	1	1	1	1	
23	Pipe (F) - High Side	Copper	315930-01	1	-				
24	Expansion Valve	HYP2-5HD4	411518-04	1	1	1	1	X	
		HYP2-5HD9	411518-07					1	
25	Cover (A) - Expansion Valve	PE Foam	315741-01	1	1	1	1	1	
26	Cover (B) - Expansion Valve	PE Foam	315741-02	1	1	1	1	1	
27	Pipe (G) - High Side	Copper	425286-01	1	1	1	1	1	
28	Pipe - Low Side	Copper	425522G01	1	-				
			210670G01		1	1	1	1	
29	Tie	CV-100	7920-0002	2	2	2	2	2	
30	Pipe (A) - Oil Cooler	Copper	425524-01	2	2	2	2	2	
31	-	-	-	-					
32	-	-	-	-					

MODEL F-1101ASU-1		TITLE C. REFRIGERATION UNIT						
INDEX NO.	DESCRIPTION	MATERIAL OR MODEL NUMBER	PART NUMBER	REQ'D NUMBER				
				J-1	J-2			
1	Compressor	KL100TD-3	2U0043-01	1	1			
2	Crankcase Heater	CH5700	425534-01	1	1			
3	Receiver Tank	RT-P-HD	2U0037-02	1	1			
4	Bracket - Condenser	G.S	425518-01	2	2			
5	Condenser - Air-cooled	-	208211G01	1	1			
6	Strap	AC	310606-01	2	2			
7	Shroud	G.S	315927G01	1	1			
8	Fan Motor	MS17ZJF-HJA7	3U0050-01	1	1			
9	Pan Blade	ABS	419547-01	1	1			
10	Fan Ring	S.S	419547P01	1	1			
11	Drier	DYN-2-HD-1	418498-01	1	-			
		KC-6749	427061-01		1			
12	Strap	G.S	425280-01	1	-			
			425280-02		1			
13	Pipe (A) - High Side	Copper	425520-01	1	1			
14	Pipe (B) - High Side	Copper	315929-01	1	1			
15	-	-	-	-				
16	Tee	Copper	420041-05	1	1			
17	Pipe (E) - High Side	Copper	425521-01	1	1			
18	Coupling (Male)	5782-6-6	426554-01	2	2			
19	Cap - Shipping	FF9080-06	426554F01	2	2			
20	Strap	G.S	416877-01	3	3			
21	-	-	-	-				
22	Pipe (C2) - High Side	Copper	420599-02	1	1			
23	-	-	-	-				
24	Expansion Valve	HYP2-5HD9	411518-07	1	1			
25	Cover (A) - Expansion Valve	PE Foam	315741-01	1	1			
26	Cover (B) - Expansion Valve	PE Foam	315741-02	1	1			
27	Pipe (G) - High Side	Copper	425286-01	1	-			
	Pipe (J) - High Side	Copper	425286-02		1			
28	Pipe - Low Side	Copper	210670G01	1	1			
29	Tie	CV-100	7920-0002	2	2			
30	Pipe (A) - Oil Cooler	Copper	425524-01	2	2			
31	-	-	-	-				
32	-	-	-	-				

MODEL		TITLE							
F-1101ASU, ASU-1		C. REFRIGERATION UNIT							
INDEX NO.	DESCRIPTION	MATERIAL OR MODEL NUMBER	PART NUMBER	REQ'D NUMBER					
				E-1	F-1	F-2	G-1	H-1	
33	Tee	Copper	417394-01	1	1	1	1	1	
34	Process Tube	Copper	315931-01	1	1	1	1	1	
35	Access Valve	TCJ-2F15-HD	417366-01	1	1	1	1	1	
36	Clamp	PA	402245-01	1	1	1	1	1	
37	Pressure Switch	SNS-2C130Y83	<a href="#">425679-01</a>	1	1	1	1	1	
38	Pipe (H) - High Side	Copper	426114-01	2	2	2	2	2	
39	-	-	-	-					
40	Tee	Copper	417394-02	2	2	2	2	2	
41	Overload	MSH16AIU	429382-01	1	1	1	1	1	

MODEL		TITLE						
F-1101ASU-1		C. REFRIGERATION UNIT						
INDEX NO.	DESCRIPTION	MATERIAL OR MODEL NUMBER	PART NUMBER	REQ'D NUMBER				
				J-1				
33	Tee	Copper	417394-01	1				
34	Process Tube	Copper	315931-01	1				
35	Access Valve	TCJ-2F15-HD	417366-01	1				
36	Clamp	PA	402245-01	1				
37	Pressure Switch	SNS-2C130YQ3	<a href="#">425679-01</a>	1				
38	Pipe (H) - High Side	Copper	426114-01	2				
39	-	-	-	-				
40	Tee	Copper	417394-02	2				
41	Overload	MSH16AIU	429382-01	1				

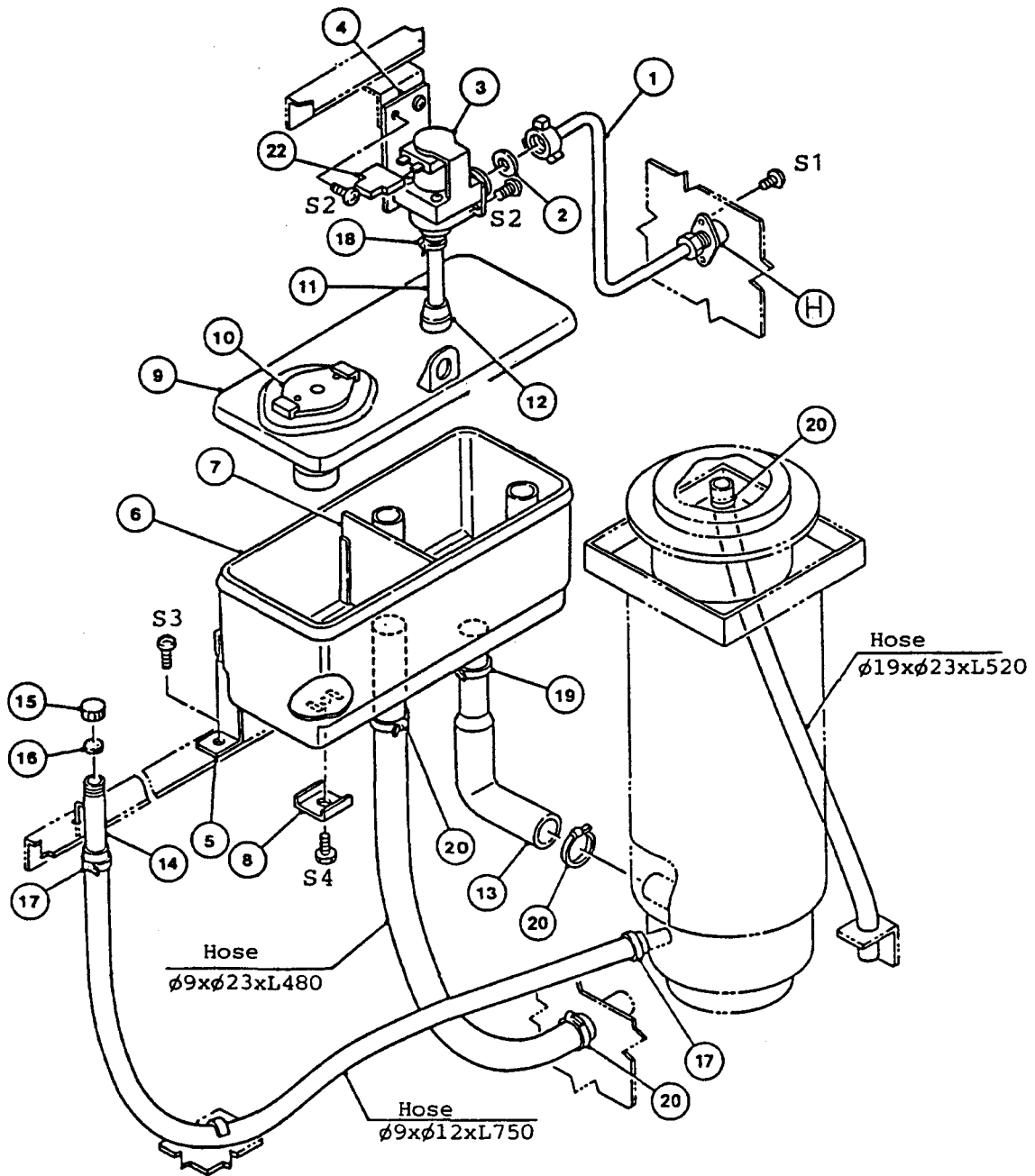

## FASTENER

- S1 - TRUSS HEAD MACHINE SCREW, STAINLESS, M4x8
- S2 - TRUSS HEAD MACHINE SCREW, M4x8
- S3 - TRUSS HEAD MACHINE SCREW, STAINLESS. M5x12
- S4 - THUMBSCREW, M4x6

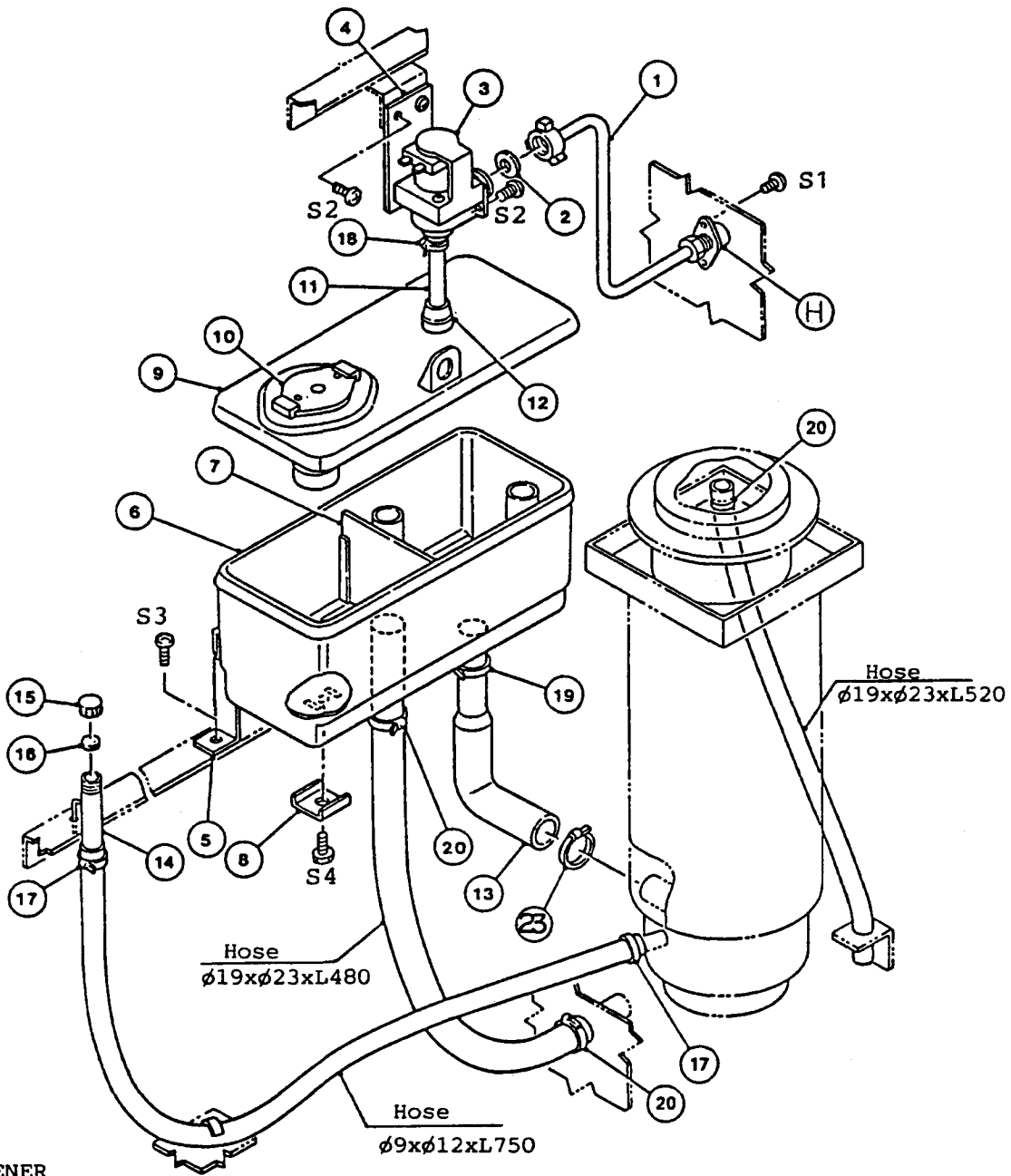

**FASTENER**

- S1 - TRUSS HEAD MACHINE SCREW, STAINLESS, M4x8
- S2 - TRUSS HEAD MACHINE SCREW, M4x8
- S3 - TRUSS HEAD MACHINE SCREW. STAINLESS, M5x12
- S4 - THUMBSCREW, M4x6

MODEL F-1101ASU, ASU-1		TITLE D. WATER CIRCUIT ASSEMBLY						
INDEX NO.	DESCRIPTION	MATERIAL OR MODEL NUMBER	PART NUMBER	REQD NUMBER				
				E-1	F-1	F-2	G-1	H-1
H	FITTING (K) ASSEMBLY	(S-0331)	310978A01	1	1	1	1	1
1	Pipe - Mater Supply	S.S	425287G01	1	1	1	1	1
2	Packing	NBR	413854-03	1	1	1	1	1
3	Water Valve	J246-086	3U0065-01	1	1	1	1	1
4	Bracket - Water Valve	G.S	425288-01	1	1	1	1	1
5	Bracket - Reservoir	G.S	315744-01	1	1	1	1	1
6	Reservoir	ABS	208125-01	1	1	1	1	1
7	Separator - Reservoir	ABS	423538-02	1	1	1	1	1
8	Collar	S.S	423416-01	1	1	1	1	1
9	Cover - Reservoir	ABS	208126-01	1	1	1	1	1
10	Float Switch	FPS-536B6IB-21	417220-01	1	1	1	1	1
11	Hose - Water Supply	EVA	425289-01	1	1	1	1	1
12	Cover - Reservoir Inlet	SI.R	415094-01	1	1	1	1	1
13	Hose - Water Supply	PP Polymer	422922-01	1	-			
		EPDM	428615-05		1	1	1	1
14	Pipe - Drain	S.S	425292G01	1	1	1	1	1
15	Cap - Drain	Brass	425293-01	1	1	1	1	1
16	Packing - Drain	Sy.R	425294-01	1	1	1	1	1
17	Clamp	HH-30N	421642-04	2	2	2	2	2
18	Clamp	MH-44N	421642-07	1	1	1	1	1
19	Clamp	MH-50N	421642-08	1	-			
		SK-183	426148-07		1	1	1	1
20	Clamp	MH-56N	421642-09	4	3	3	3	3
21	-	-	-	-				
22	2-Pin Connector	J24032422	414358-01	1	-			
23	Clamp	SK-250	426148-08		1	1	1	1



MODEL		TITLE						
F-1101ASU-1		D. WATER CIRCUIT ASSEMBLY						
INDEX NO.	DESCRIPTION	MATERIAL OR MODEL NUMBER	PART NUMBER	REQ'D NUMBER				
				J-1	J-2			
H	FITTING (K) ASSEMBLY	(S-0331)	310978A01	1	1			
1	Pipe - Water Supply	S.S	425287G01	1	1			
2	Packing	NBR	413854-03	1	1			
3	Water Valve	J246-086	3U0065-01	1	1			
4	Bracket - Water Valve	G.S	425288-01	1	1			
5	Bracket - Reservoir	G.S	315744-01	1	1			
6	Reservoir	ABS	208125-01	1	1			
7	Separator - Reservoir	ABS	423538-02	1	1			
8	Collar	S.S	423416-01	1	1			
9	Cover - Reservoir	ABS	208126-01	1	1			
10	Float Switch	FFS-536B6IB-21	417220-01	1	X			
		TW-1221-101	435490-01		1			
11	Hose - Water Supply	EVA	425289-01	1	1			
12	Cover - Reservoir Inlet	SI.R	415094-01	1	1			
13	Hose - Water Supply	EPDM	428615-05	1	1			
14	Pipe - Drain	S.S	425292G01	1	1			
15	Cap - Drain	Brass	425293-01	1	1			
16	Packing - Drain	Sy.R	425294-01	1	1			
17	Clamp	MH-30N	421642-04	2	2			
18	Clamp	MH-44N	421642-07	1	1			
19	Clamp	SK-183	426148-07	1	1			
20	Clamp	MH-56N	421642-09	3	3			
21	-	-	-	-				
22	-	-	-	-				
23	Clamp	SK-250	426148-08	1	1			

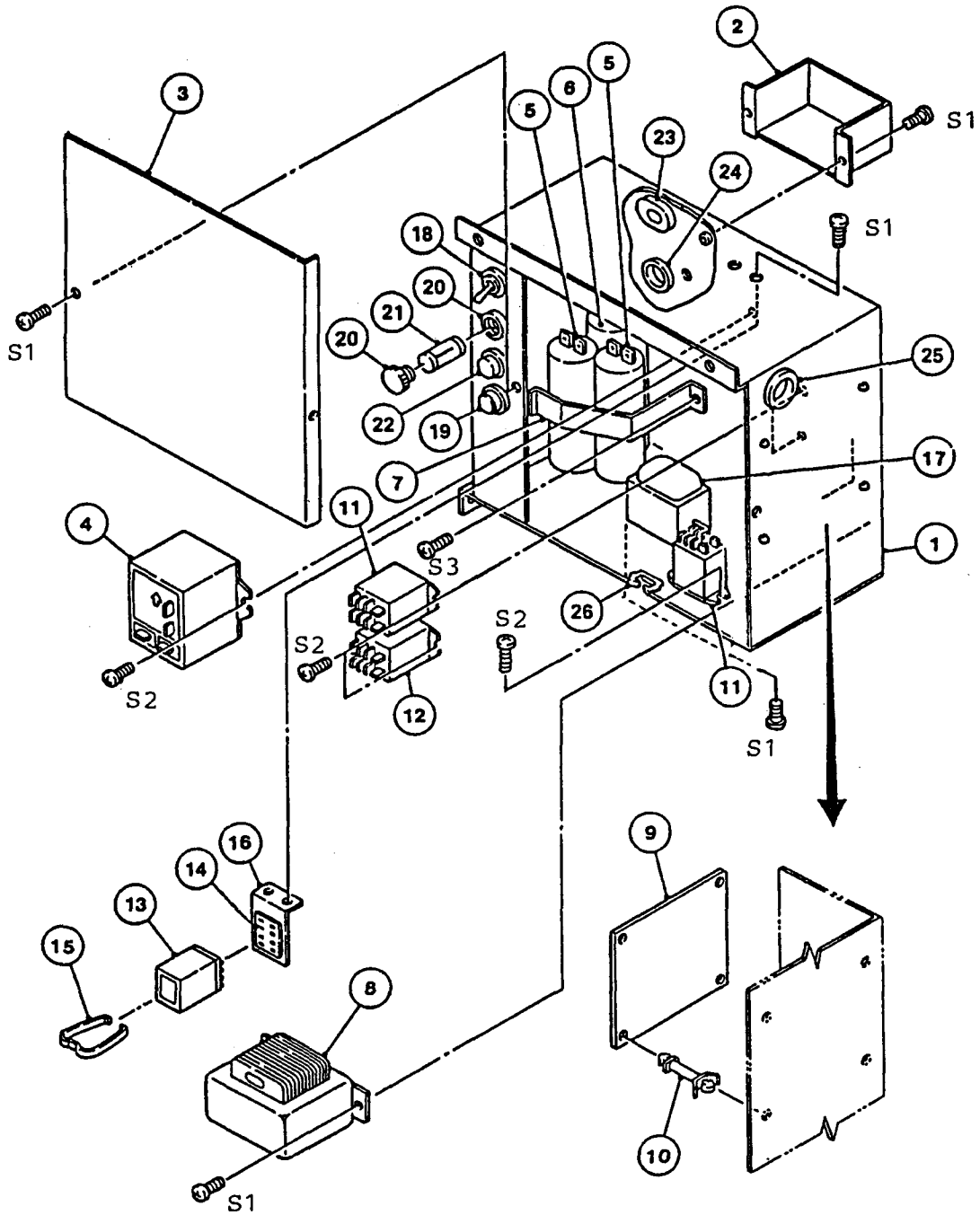

FASTENER

- S1 - TRUSS HEAD MACHINE SCREW, M4x6
- S2 - TRUSS HEAD TAPPING SCREW, M3x8
- S3 - TRUSS HEAD MACHINE SCREW, M4x8

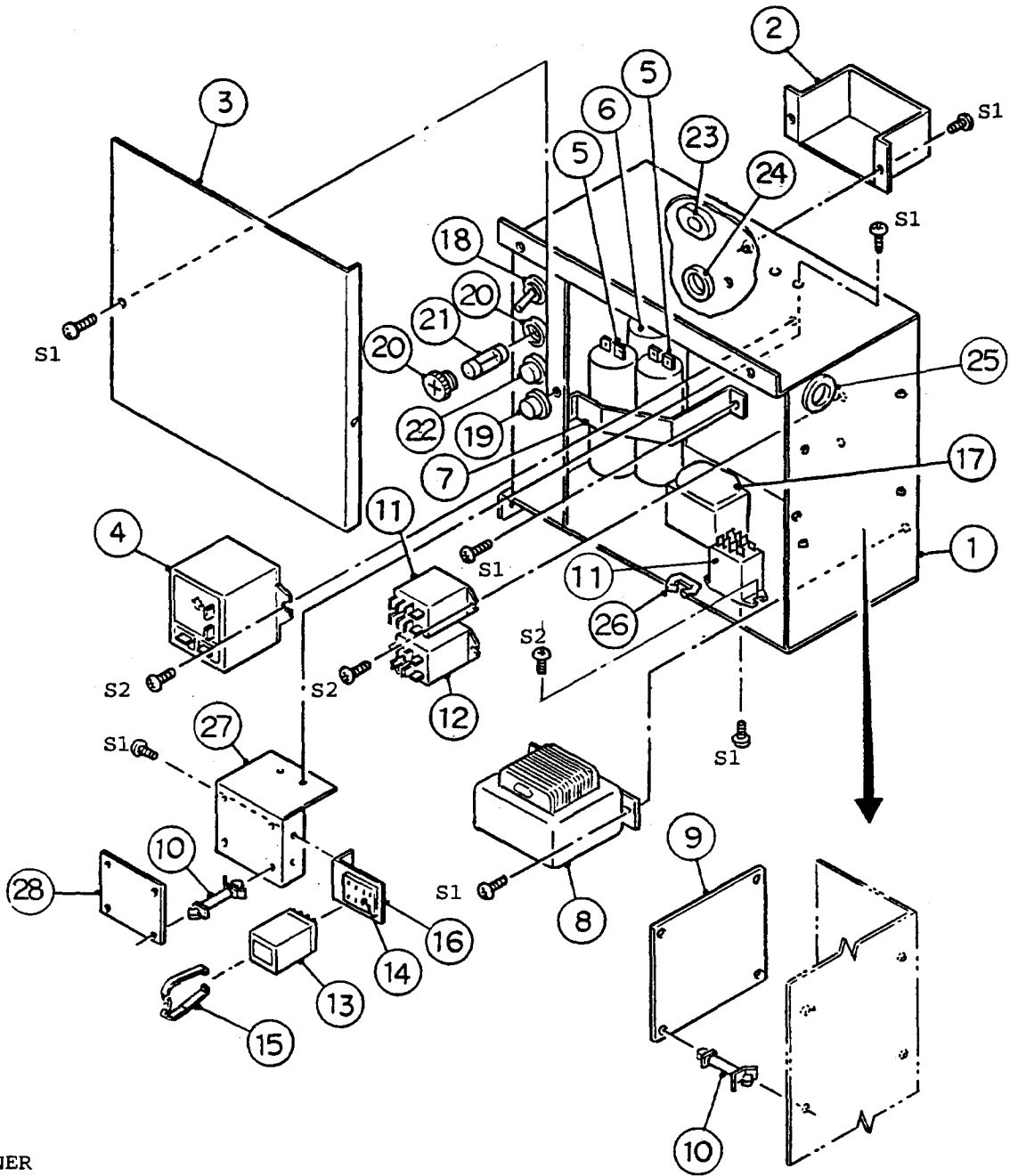

**FASTENER**

S1 - TRUSS HEAD MACHINE SCREW, M4x8  
 S2 - TRUSS HEAD TAPPING SCREW, M3x8

MODEL		TITLE						
F-1101ASU, ASU-1		E. CONTROL BOX ASSEMBLY						
INDEX NO.	DESCRIPTION	MATERIAL OR MODEL NUMBER	PART NUMBER	REQ'D NUMBER				
				E-1	F-1	F-2	G-1	H-1
1	Control Box	G.S	315746G06	1	1	1	1	1
2	Cover - Connector	G.S	425302-01	1	1	1	1	1
3	Cover - Control Box	G.S	425301-01	1	1	1	1	1
4	Starter	FST-275B	422619-01	1	1	1	1	1
5	Start Capacitor	MS180F100(J)-R	<a href="#">3U0054-01</a>	2	2	2	2	2
6	Run Capacitor	PMT-40250CP)	3U0058-01	1	1	-		
7	Strap - Capacitor	PMT-SH	431200-01			1	1	1
		G.S	425299-01	1	1	-		
8	Transformer		431394-01			1	1	1
		TR5268	2U0041-01	1	1	1	1	1
9	Timer Board	424292	424292-01	1	1	1	1	1
10	Board Support	KGLS-6S	414929-01	4	4	4	4	4
11	Relay	LY1F-US	422608-02	2	2	2	2	-
		LY1F	418271-04					2
12	Relay	LY2ZFAG-US	427318-01	1	1	1	1	-
		LY2ZF	406132-06					1
13	Keep Relay	MY2K-HO	418524-03	1	1	1	1	1
14	Socket - Relay	PY-14	<a href="#">408328-02</a>	1	1	1	1	1
15	Clamp - Relay	PYC-P	411353-01	1	1	1	1	1
16	Bracket - Relay	G.S	425300-01	1	1	1	1	1
17	Thermostat	A22-2504	<a href="#">425202-01</a>	1	1	1	1	1
18	Toggle Switch	S-421	3U0039-01	1	1	1	1	1
19	Push Button Switch	SB-4011N/OT3959	<a href="#">420466-01</a>	1	1	1	1	1
20	Fuse Holder	FH032	424288-01	1	1	1	1	1
21	Fuse	PGAO-2, 1A	<a href="#">420468-03</a>	1	1	1	1	1
22	Overload - Gear Motor	W58xBIA4A-2	<a href="#">425201-01</a>	1	1	1	1	1
23	Bushing	SR-4K-4	420472-01	1	1	1	1	1
24	Bushing	SB-625-8	<a href="#">420470-01</a>	1	1	1	1	1
25	Bushing	SB-1093-15	<a href="#">420470-03</a>	1	1	1	1	1
26	Edge Saddle	EDS-1	421552-01	1	1	1	1	1

MODEL F-1101ASU-1		TITLE E. CONTROL BOX ASSEMBLY			REQ'D NUMBER				
INDEX NO.	DESCRIPTION	MATERIAL OR MODEL NUMBER	PART NUMBER	J-1					
				1	Control Box	G.S	315746G06	1	
2	Cover - Connector	G.S	425302-01	1					
3	Cover - Control Box	G.S	425301-01	1					
4	Starter	FST-275B	422619-01	1					
5	Start Capacitor	MS180F100(J)-R	<a href="#">3U0054-01</a>	2					
6	Run Capacitor	PMT-SH	431200-01	1					
7	Strap - Capacitor	G.S	431394-01	1					
8	Transformer	TR5268	2U0041-01	1					
9	Timer Board	424292	424292-01	1					
10	Board Support	KGLS-6S	414929-01	8					
11	Relay	LY1F	418271-04	2					
12	Relay-	LY2ZF	406132-06	1-					
13	Keep Relay	MY2K-HO	418524-03	1					
14	Socket - Relay	PY-14	<a href="#">408328-02</a>	1					
15	Clamp - Relay	PYC-P	411353-01	1					
16	Bracket - Relay	G.S	425300-01	1					
17	Thermostat	A10-9756	<a href="#">420465-01</a>	1					
18	Toggle Switch	S-421	3U0039-01	1					
19	Push Button Switch	SB-4011N/OT3959	<a href="#">420466-01</a>	1					
20	Fuse Holder	FH032	424288-01	1					
21	Fuse	FGAO-2, 1A	<a href="#">420468-03</a>	1					
22	Overload - Gear Motor	W58xBIA4A-2	<a href="#">425201-01</a>	1					
23	Bushing	SR-4K-4	420472-01	1					
24	Bushing	SB-625-8	<a href="#">420470-01</a>	1					
25	Bushing	SB-1093-15	<a href="#">420470-03</a>	1					
26	Edge Saddle	EDS-1	421552-01	1					
27	Beeper Bracket	G.S	323312-01	1					
28	Beeper	-	435937-01	1					

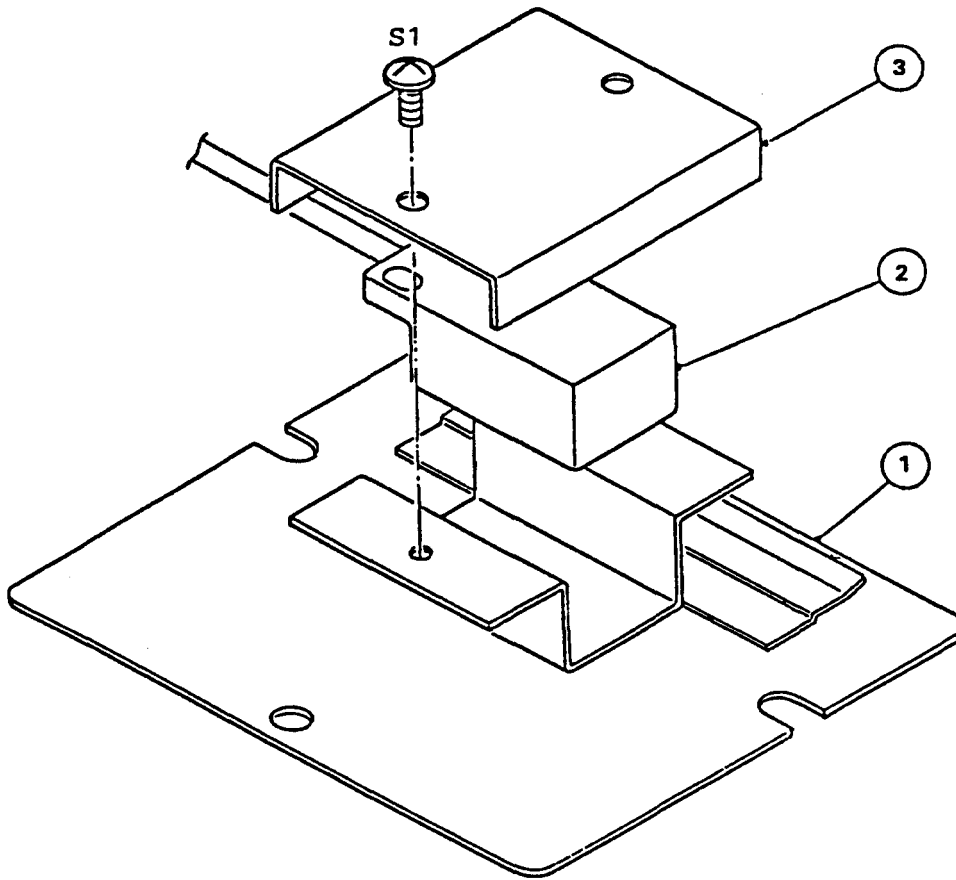

FASTENER

S1 - TRUSS HEAD MACHINE SCREW, STAINLESS, M4x6

MODEL		TITLE						
F-1101ASU, ASU-1		F. BIN SWITCH ASSEMBLY						
INDEX NO.	DESCRIPTION	MATERIAL OR MODEL NUMBER	PART NUMBER	REQ'D NUMBER				
				E-1	F-1	F-2	G-1	H-1
1	Bracket - Switch	S.S	317648G01	1	1	1	1	1
2	Proximity Switch - Bin Control	RS-601	427223-01	1	1	1	1	1
3	Bracket - Proximity Switch	S.S	427158-01	1	1	1	1	1

MODEL		TITLE					
F-1101ASU-1		P. BIN SWITCH ASSEMBLY					
INDEX NO.	DESCRIPTION	MATERIAL OR MODEL NUMBER	PART NUMBER	REQ'D NUMBER			
				J-1			
1	Bracket - Switch	S.S	317648G01	1			
2	Proximity Switch - Bin Control	RS-601	427223-01	1			
3	Bracket - Proximity Switch	S.S	427158-01	1			



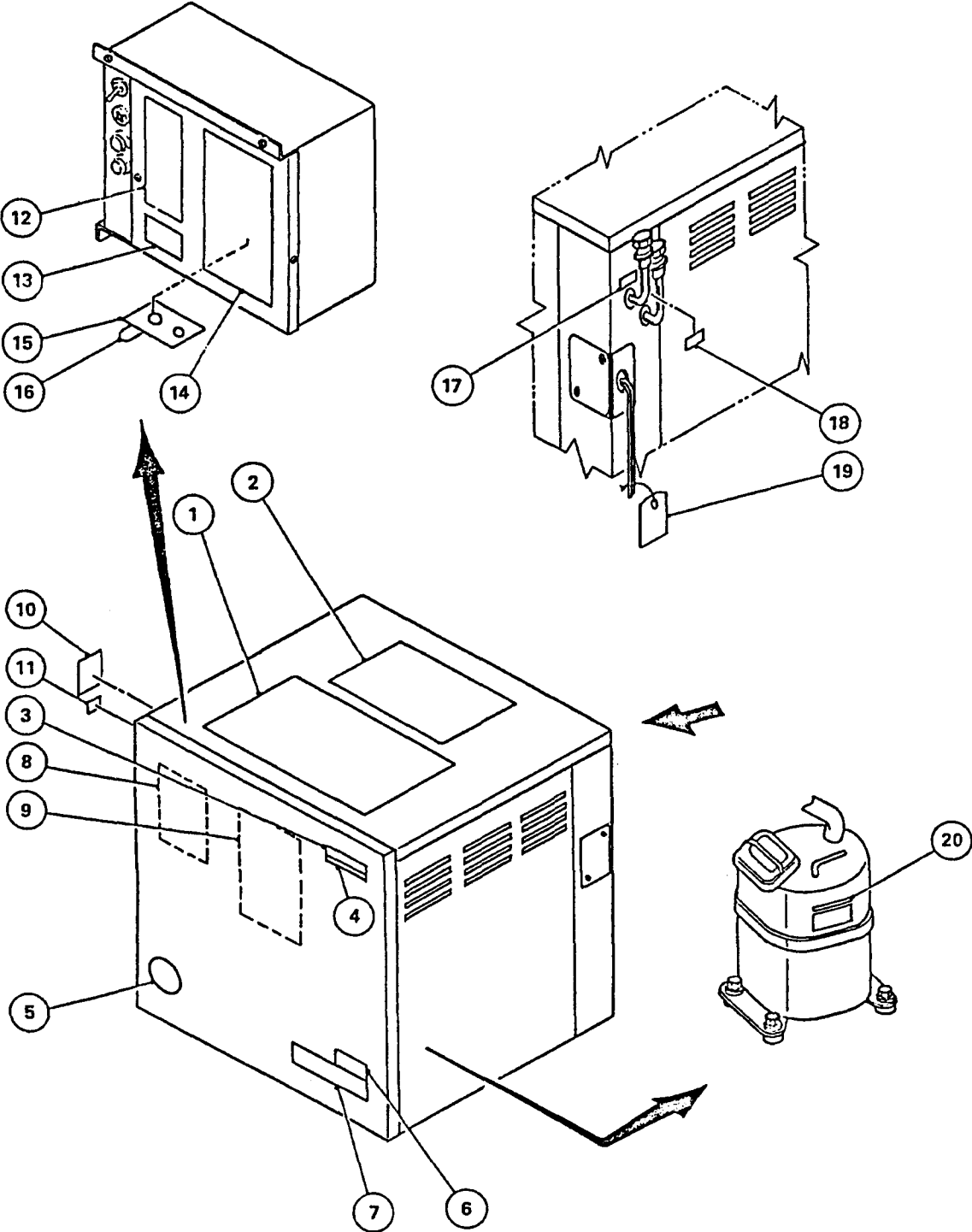

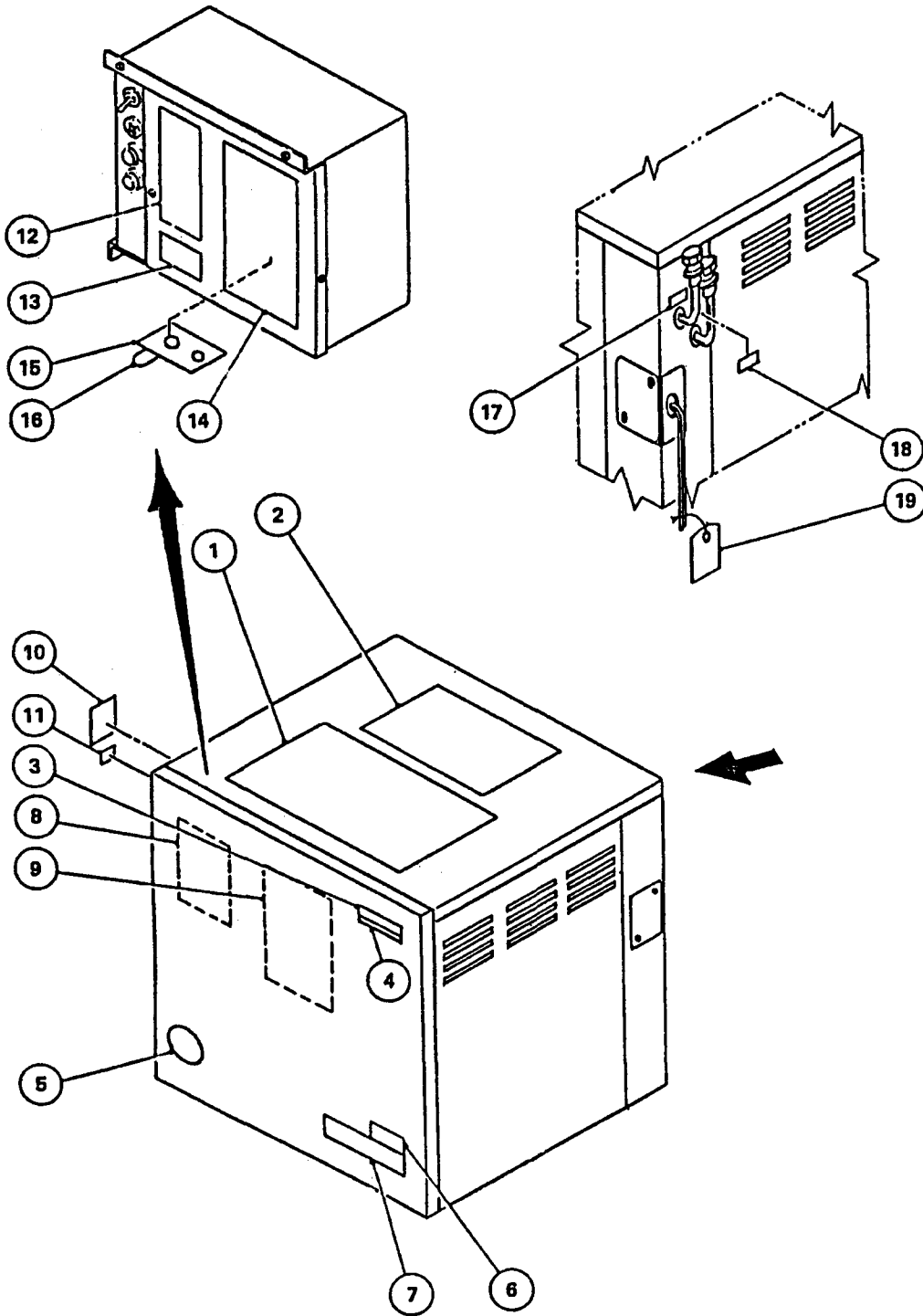

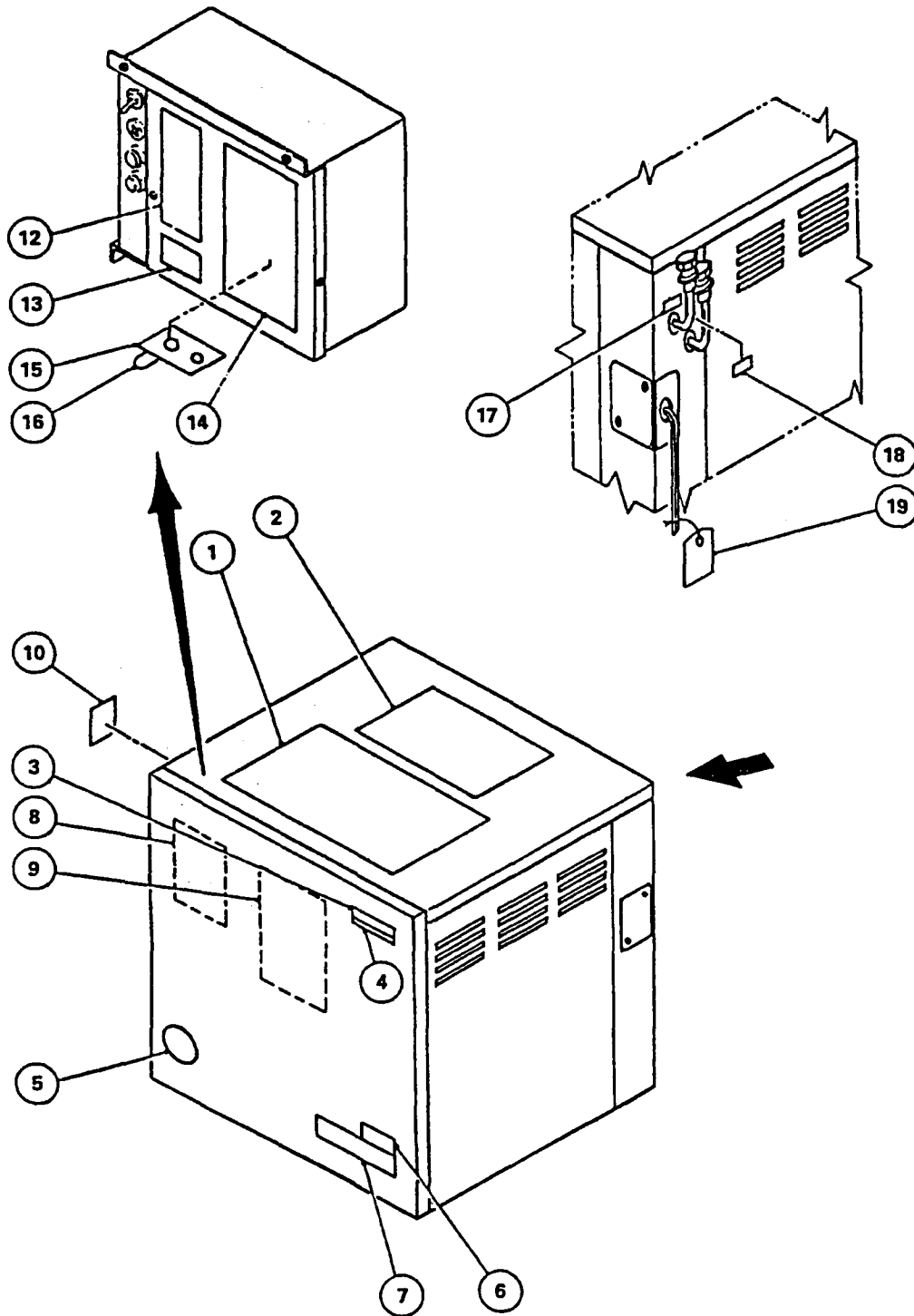

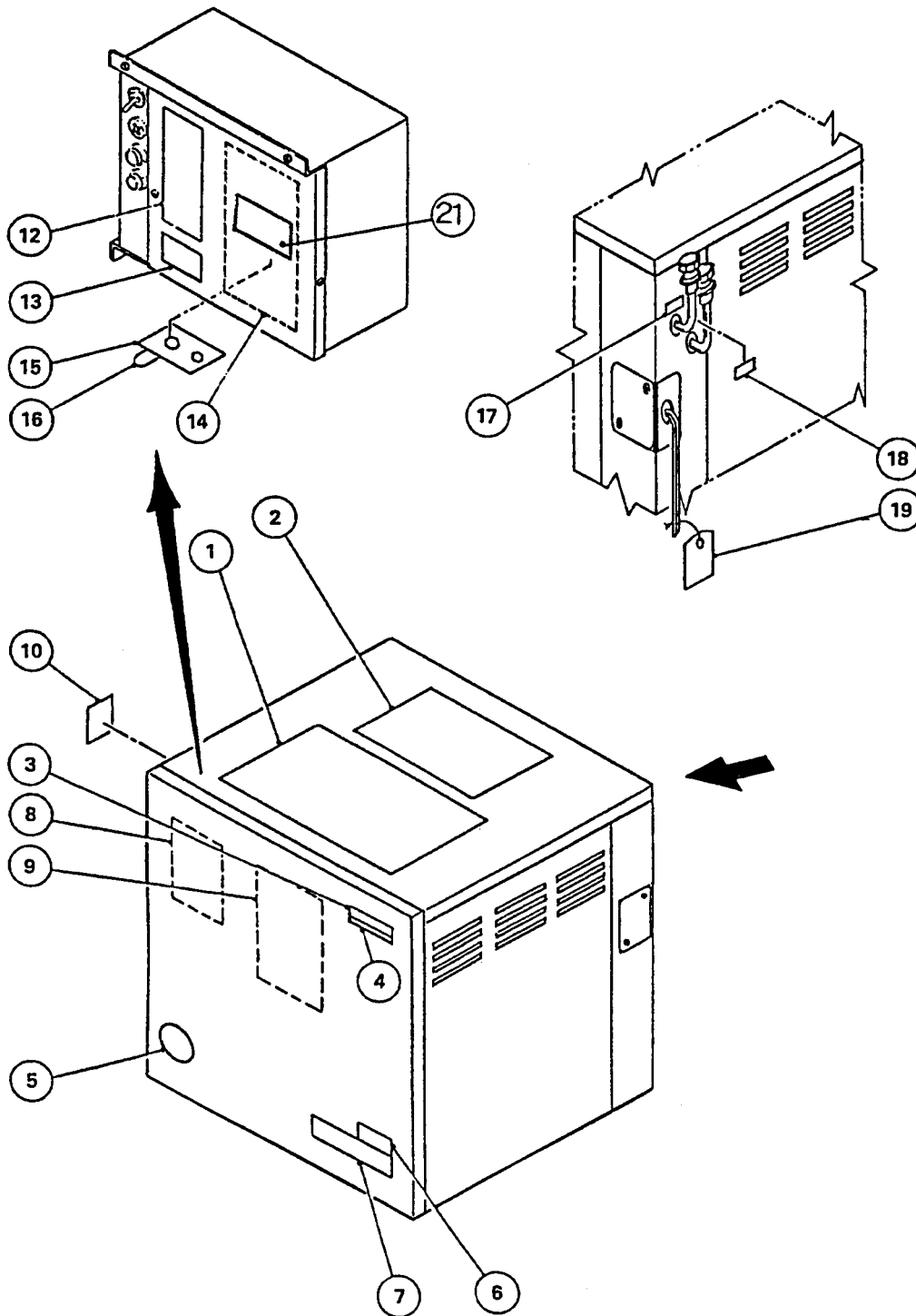

MODEL F-1101ASU, ASU-1		TITLE G. LABEL LOCATION							
INDEX NO.	DESCRIPTION	MATERIAL OR MODEL NUMBER	PART NUMBER	REQ'D NUMBER					
				E-1	F-1	F-2	G-1	H-1	
1	Instruction Sheet - Inst. Ope.	Paper	208144-01	1	1	1	1	1	
2	Instruction Sheet - Bin Inst.	Paper	208145-01	1	1	1	1	1	
3	Emblem (L) - HOSHIZAKI	ABS	418634G01	1	1	1	1	1	
4	Label - Model Number	PETP Film	425439-**	1	-				
			431137-**		1	1	1	1	
5	Label - Penguin	PETP Film	410994-01	1	1	1	1	1	
6	Label - Warning	PVC Film	425323-01	1	1	1	1	1	
7	Label - Operation, Spout Cont.	PETP Film	425325-01	1	1	1	1	1	
8	Label - Operation	PVC Film	316381-01	1	1	1	1	1	
9	Label - Cleaning	PVC Film	208146-01	1	1	1	1	X	
			211624-01					1	
10	Nameplate	PES Film	428911-01	1	-				
			431138-01		1	1	1	-	
			432829-01					1	
11	Label - NSF	-	423170-01	1	1	1	1	-	
12	Label - Control Box	PETP Film	425329-01	1	1	1	1	1	
13	Label - Danger	PVC Film	425322-01	1	1	1	1	1	
14	Label - Wiring Diagram	PVC Film	317655-01	1	1	1	1	1	
15	Label - Spout Control	PETP Film	428016-01	1	1	1	1	1	
16	Label - Factory Adjusted	PETP Film	419404-01	1	1	1	1	1	
17	Label - Arrow, "Out"	PETP Film	420743-01	1	1	1	1	1	
18	Label - Arrow, "In"	PETP Film	420743-02	1	1	1	1	1	
19	Tag - Fan Motor Leads	Paper	420742-01	1	1	1	1	1	
20	Label - Thermally Protected	PES Film	427316-01	1	1	1	-		

\*\* is as same as the Auxiliary Code. 17

MODEL F-1101ASU-1		TITLE G. LABEL LOCATION		REQ'D NUMBER				
INDEX NO.	DESCRIPTION	MATERIAL OR MODEL NUMBER	PART NUMBER	J-1				
				1	Instruction Sheet - Inst. Ope.	Paper	208144-01	1
2	Instruction Sheet - Bin Inst.	Paper	208145-01	1				
3	Emblem (L) - HOSHIZAKI	ABS	418634G01	1				
4	Label - Model Number	PETP Film	431137-**	1				
5	Label - Penguin	PETP Film	410994-01	1				
6	Label - Warning	PVC Film	425323-01	1				
7	Label - Operation, Spout Cont.	PETP Film	425325-01	1				
8	Label - Operation	PVC Film	316381-01	1				
9	Label - Cleaning	PVC Film	211624-01	1				
10	Nameplate	PES Film	432829-01	1				
11	-	-	-	-				
12	Label - Control Box	PETP Film	425329-01	1				
13	Label - Danger	PVC Film	425322-01	1				
14	Miring Label	PVC Film	323350-01	1				
15	Label - Bin Thermostat	PETP Film	435984-01	1				
16	Label - Factory Adjusted	PETP Film	419404-01	1				
17	Label - Arrow, "Out"	PETP Film	420743-01	1				
18	Label - Arrow, "In"	PETP Film	420743-02	1				
19	Tag - Fan Motor Leads	Paper	420742-01	1				
20	-	-	-	-				
21	Warning Label	PVC Film	435955-01	1				

\*\* is as same as the Auxiliary Code.

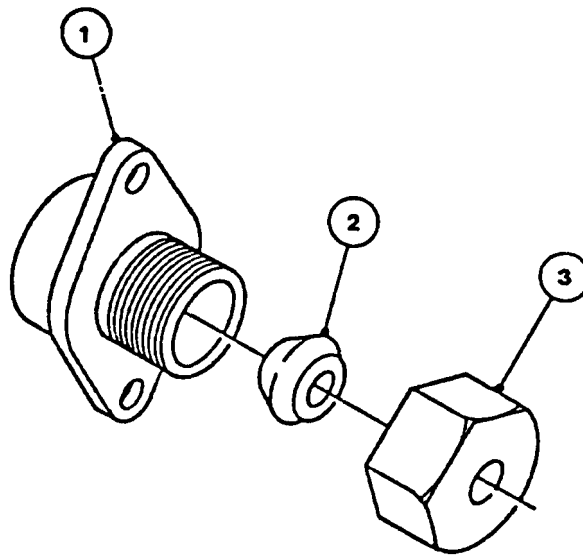

MODEL		TITLE						
F-1101ASU, ASU-1		H. FITTING (K) ASSEMBLY						
INDEX NO.	DESCRIPTION	MATERIAL OR MODEL NUMBER	PART NUMBER	REQ'D NUMBER				
				E-1	F-1	F-2	G-1	H-1
1	Fitting (K)	Brass Casting	310978-01	1	1	1	1	1
2	Packing (C)	Sy.R	415715-02	1	1	1	1	1
3	Nut (B)	Brass	415713-02	1	1	1	1	1



MODEL		TITLE						
F-1101ASU-1		H. FITTING (K) ASSEMBLY						
INDEX NO.	DESCRIPTION	MATERIAL OR MODEL NUMBER	PART NUMBER	REQ'D NUMBER				
				J-1				
1	Fitting (K)	Brass Casting	310978-01	1				
2	Packing (C)	Sy.R	415715-02	1				
3	Nut (B)	Brass	415713-02	1				

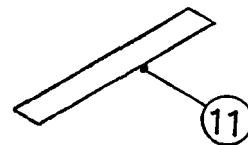
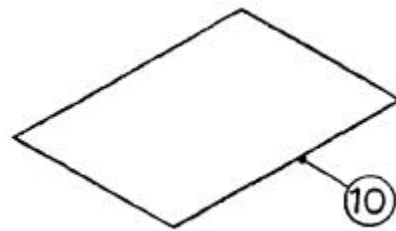
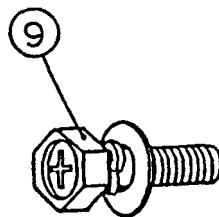
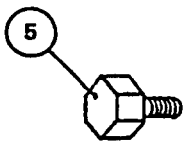
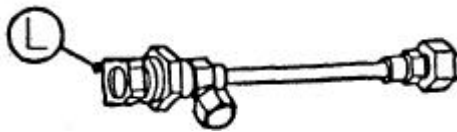
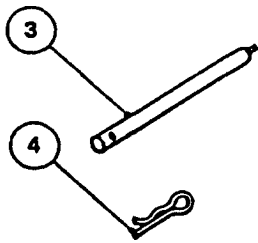
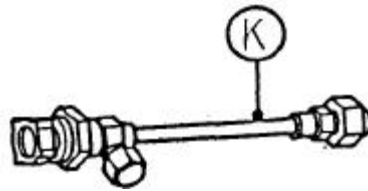
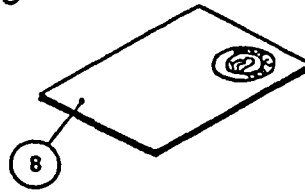
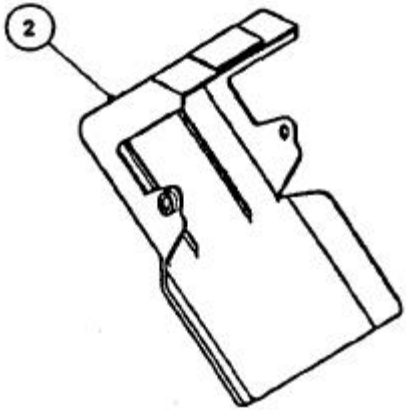
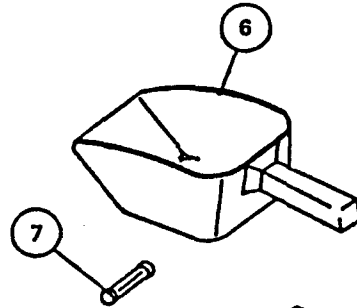
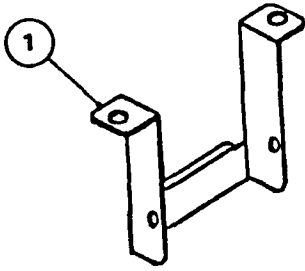

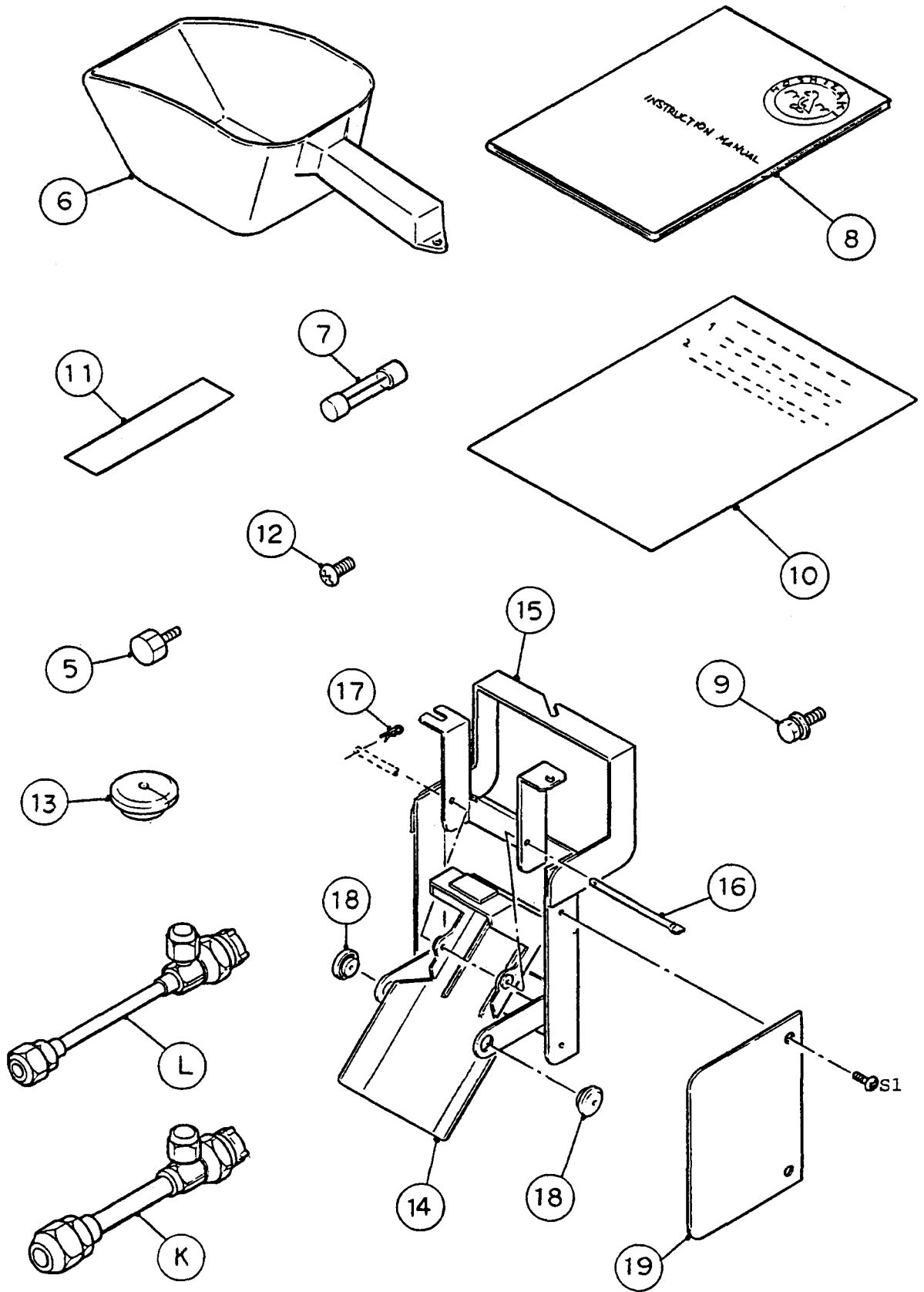

FASTENER

S1 - TRUSS HEAD MACHINE SCREW, STAINLESS, M4x8

MODEL		TITLE						
F-1101ASU, ASU-1		J. ACCESSORIES						
INDEX NO.	DESCRIPTION	MATERIAL OR MODEL NUMBER	PART NUMBER	REQ'D NUMBER				
				E-1	F-1	F-2	G-1	H-1
K	COUPLING (FEMALE)	(S-0372)	421676A01	1	1	1	1	1
L	COUPLING (FEMALE)	(S-0373)	421677A01	1	1	1	1	1
1	Bracket - Actuator	S.S	428003-01	1	1	1	1	1
2	Actuator - Switch	ABS	209168G01	1	1	1	1	1
3	Shaft	S.S	412337-03	1	1	1	1	1
4	Snap Pin	S.S, SSP-4	715S-0004	1	1	1	1	1
5	Thumbscrew	S.S, ABS	415949G04	3	3	3	3	3
6	Scoop	PE	208185-01	1	1	1	1	1
7	Fuse	FGA-2, 1A	420468-03	1	1	1	1	1
8	Instruction Manual	Paper	9021G-16A	1	-			
			91U2AA10A		1	1	1	X
			91U2AA10B					1
9	Bolt And Washer Assy SW	S.S. M8x16	-	2	2	2	2	2
10	Instruction Sheet - Actuator	Paper	317651-01	1	1	1	1	1
11	Instruction Sheet - Fastener	Paper	427122-01	1	1	1	1	1
12	Truss Head Machine Screw	S.S, M4x30	-	2	2	2	2	2

MODEL F-1101ASU-1		TITLE J. ACCESSORIES						
INDEX NO.	DESCRIPTION	MATERIAL OR MODEL NUMBER	PART NUMBER	REQ'D NUMBER				
				J-1				
K	COUPLING (FEMALE)	(S-0372)	421676A01	1				
L	COUPLING (FEMALE)	(S-0373)	421677A01	1				
1	Bracket - Actuator	S.S	428003-01	-				
2	Actuator - Switch	ABS	<a href="#">209168G01</a>	-				
3	Shaft	S.S	<a href="#">412337-03</a>	-				
4	Snap Pin	S.S, SSP-4	<a href="#">715S-0004</a>	-				
5	Thumbscrew	S.S, ABS	415949G04	3				
6	Scoop	PE	208185-01	1				
7	Fuse	FGA-2, 1A	<a href="#">420468-03</a>	1				
8	Instruction Manual	Paper	91U2AA10C	1				
9	Bolt And Masher Assy SW	S.S, M8x16	-	2				
10	Instruction Sheet - Actuator	Paper	317651-01	1				
11	Instruction Sheet - Fastener	Paper	<a href="#">427122-01</a>	1				
12	Truss Head Machine Screw	S.S, M4x30	-	2				
13	Bushing - Cappillary Tube	EP Rubber	<a href="#">425307-01</a>	1				
14	Actuator - Switch		<a href="#">209168G01</a>	1				
15	Bin Control Bracket	Bin Control	<a href="#">323306G01</a>	1				
16	Shaft	Assembly	<a href="#">412337-03</a>	1				
17	Snap Pin	<a href="#">(323318A01)</a>	<a href="#">715S-0004</a>	1				
18	Bushing - Cappillary Tube		<a href="#">425307-01</a>	2				
19	Paddle Cover (B)		435869-01	1				

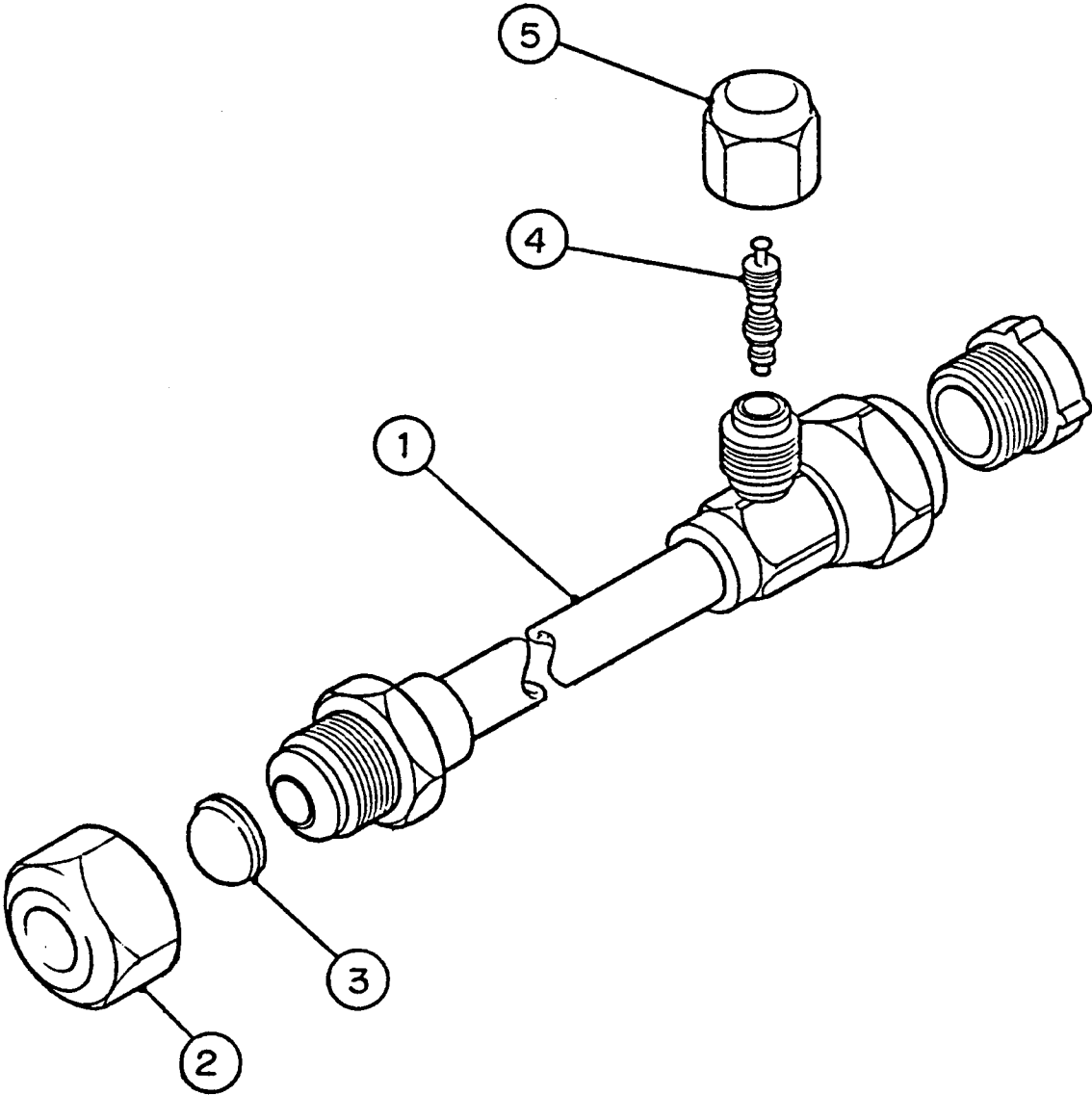

MODEL F-1101ASU, ASU-1		TITLE K. COUPLING (FEMALE)						
INDEX NO.	DESCRIPTION	MATERIAL OR MODEL NUMBER	PART NUMBER	REQ'D NUMBER				
				E-1	F-1	F-2	G-1	H-1
1	Coupling (Female)	-	421675G01	1	1	1	1	1
2	Flare Nut	Brass	403695-01	1	1	1	1	1
3	Cap - Flared	Copper	418295-02	1	1	1	1	1
4	Valve Core	-	421671-01	1	1	1	1	1
5	Cap	Brass	421672-01	1	1	1	1	1

MODEL F-1101ASU-1		TITLE K. COUPLING (FEMALE)						
INDEX NO.	DESCRIPTION	MATERIAL OR MODEL NUMBER	PART NUMBER	REQ'D NUMBER				
				J-1				
1	Coupling (Female)	-	421675G01	1				
2	Flare Nut	Brass	403695-01	1				
3	Cap - Flared	Copper	418295-02	1				
4	Valve Core	-	421671-01	1				
5	Cap	Brass	421672-01	1				



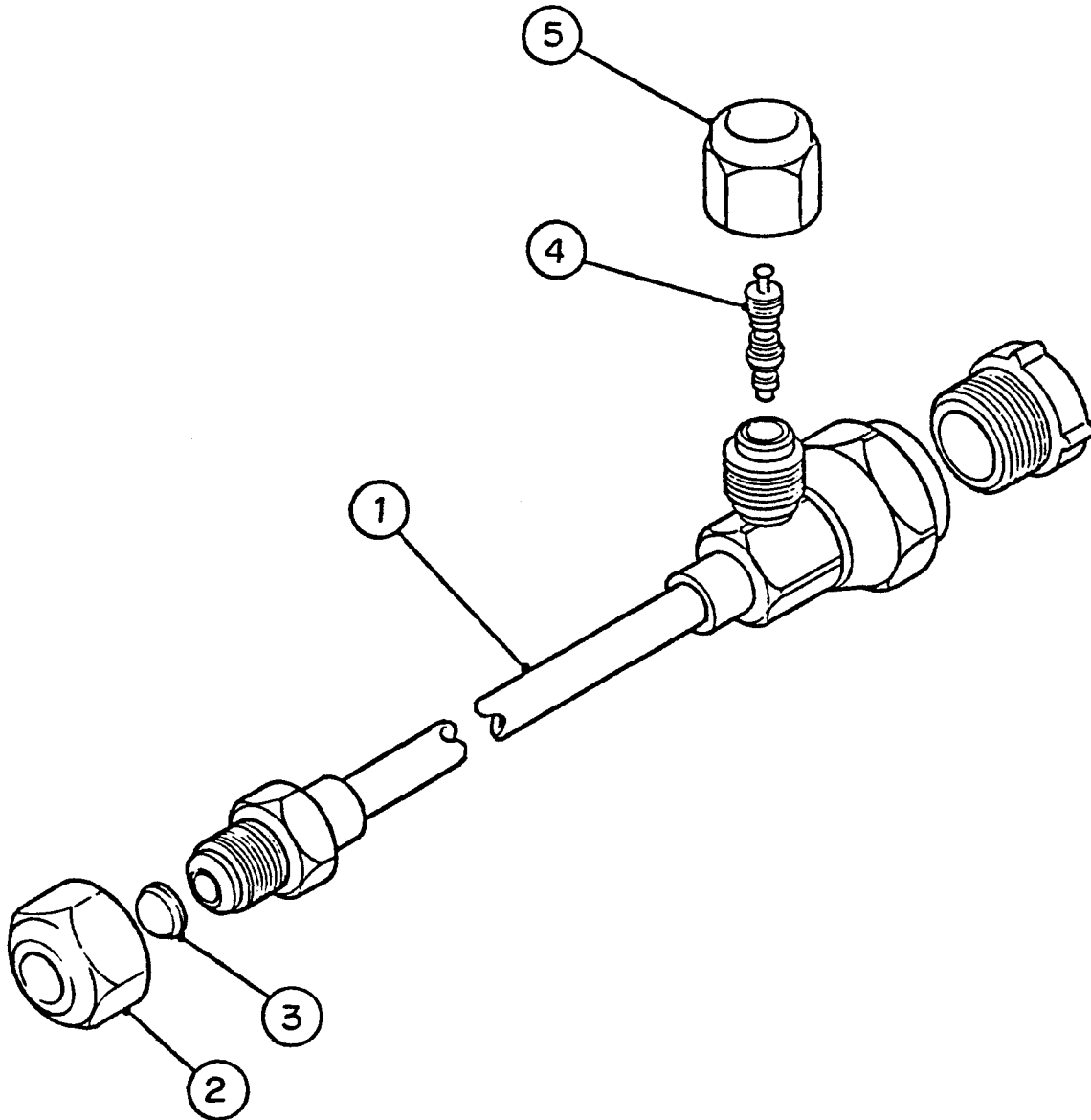

MODEL		TITLE						
F-1101ASU, ASU-1		L. COUPLING (FEMALE)						
INDEX NO.	DESCRIPTION	MATERIAL OR MODEL NUMBER	PART NUMBER	REQ'D NUMBER				
				E-1	F-1	F-2	G-1	H-1
1	Coupling (Female)	-	421673G01	1	1	1	1	1
2	Flare Nut	Brass	419177-01	1	1	1	1	1
3	Cap - Flared	Copper	418295-01	1	1	1	1	1
4	Valve Core	-	421671-01	1	1	1	1	1
5	Cap	Brass	421672-01	1	1	1	1	1

MODEL		TITLE					
F-1101ASU-1		L. COUPLING (FEMALE)					
INDEX NO.	DESCRIPTION	MATERIAL OR MODEL NUMBER	PART NUMBER	REQ'D NUMBER			
				J-1			
1	Coupling (Female)	-	421673G01	1			
2	Flare Nut	Brass	419177-01	1			
3	Cap - Flared	Copper	418295-01	1			
4	Valve Core	-	421671-01	1			
5	Cap	Brass	421672-01	1			

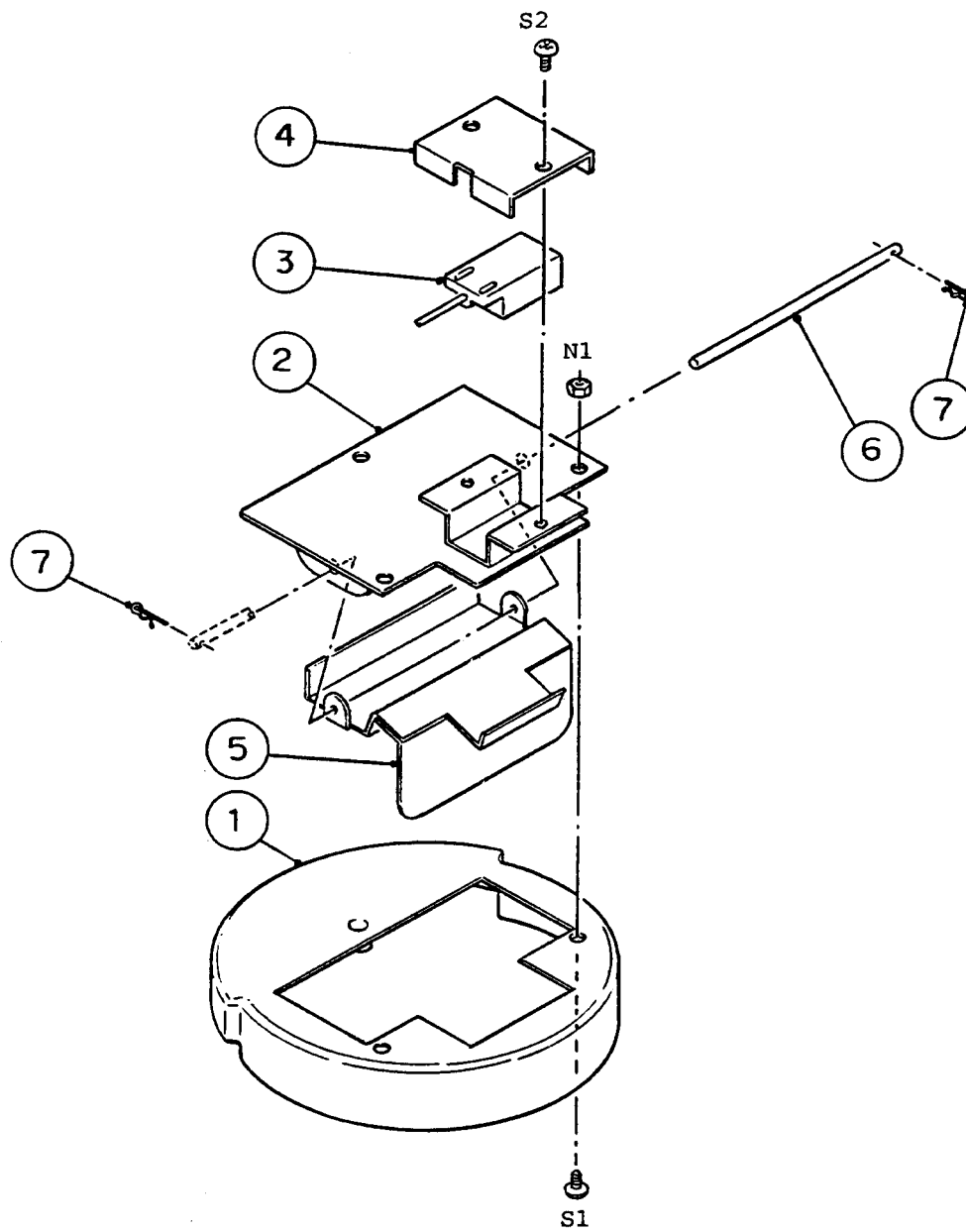

FASTENER

S1 - TRUSS HEAD MACHINE SCREW, STAINLESS, M4x8

S2 - TRUSS HEAD MACHINE SCREW, STAINLESS, M4x6

N1 - U Nut, STAINLESS, M4

MODEL F-1101ASU-1		TITLE M. SPOUT CONTROL ASSEMBLY					
INDEX NO.	DESCRIPTION	MATERIAL OR MODEL NUMBER	PART NUMBER	REQ'D NUMBER			
				J-1			
1	Cover - Chute	ABS	213116G01	1			
2	Spout Cover	S.S	323307G01	1			
3	Proximity Switch	RS-601	427223-01	1			
4	Bracket - Proximity Switch	S.S	427158-01	1			
5	Paddle	S.S	323310G01	1			
6	Axle	S.S	435873-01	1			
7	Snap Pin	S.S, SSP-4	715S-0004	2			

TOOTHED LOCK  
WASHERS B4

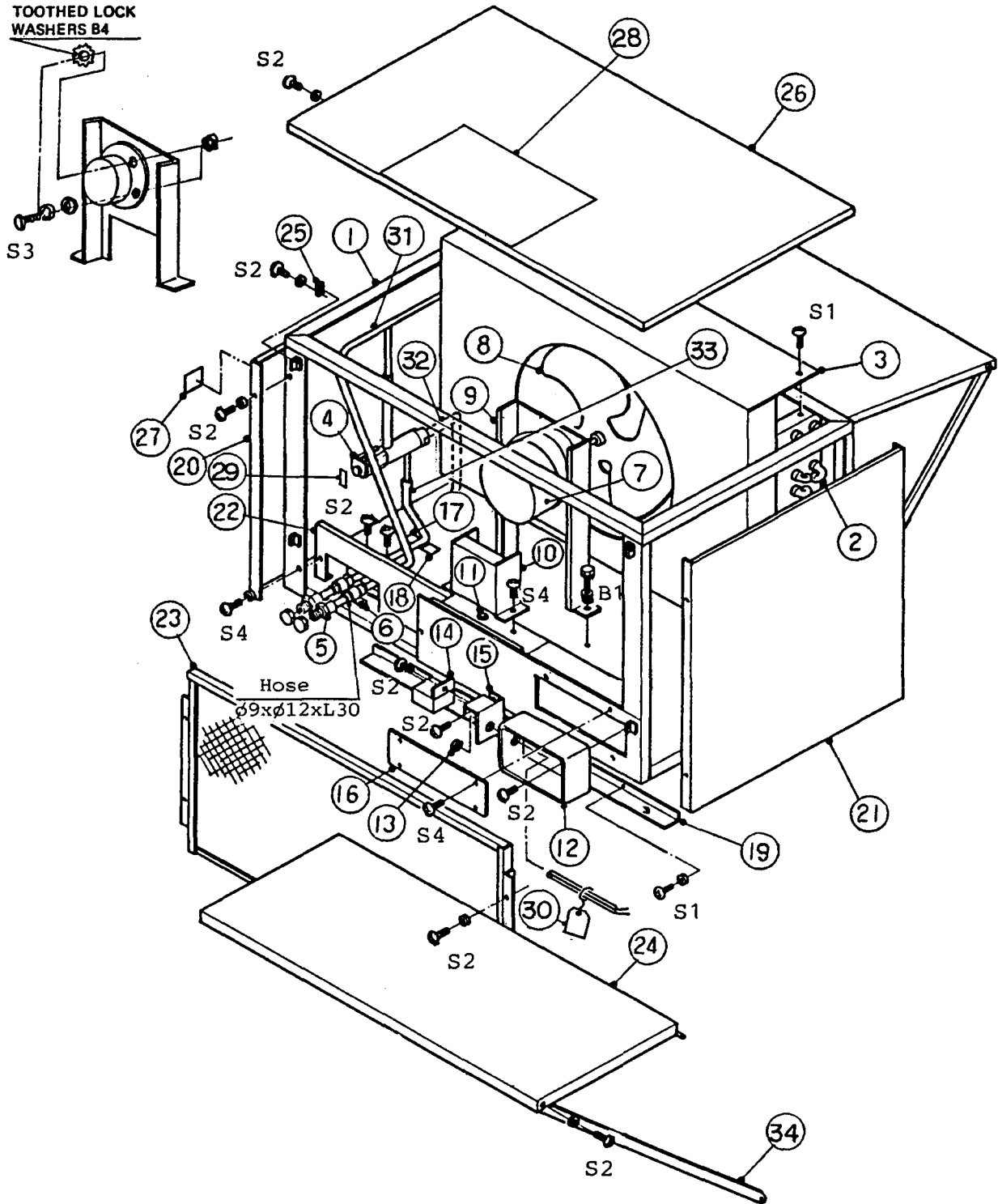

FASTENER

- S1 - TRUSS HEAD MACHINE SCREW, STAINLESS, M4x8
- S2 - TRUSS HEAD TAPPING SCREW, STAINLESS, M4x8
- S3 - TRUSS HEAD MACHINE SCREW, STAINLESS, M4x12
- S4 - TRUSS HEAD MACHINE SCREW, STAINLESS, M4x6
- B1 - HEXAGON BOLT AND SPRING WASHER + PLAIN WASHER ASSY, STAINLESS, M5x12

TOOTHED LOCK  
WASHERS B4

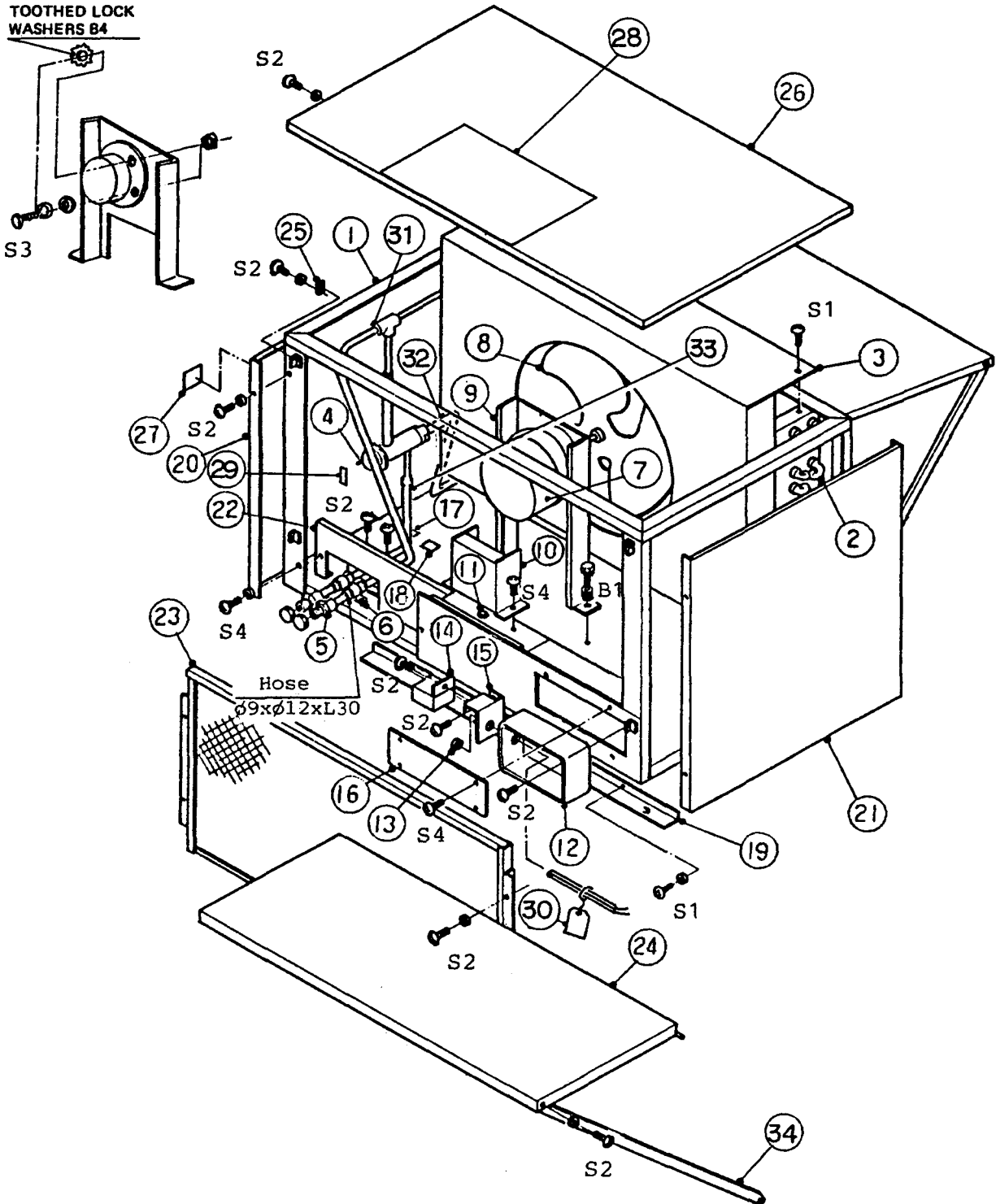

FASTENER

- S1 - TRUSS HEAD MACHINE SCREW, STAINLESS, M4x8
- S2 - TRUSS HEAD TAPPING SCREW, STAINLESS, M4x8
- S3 - TRUSS HEAD MACHINE SCREW, STAINLESS, M4x12
- S4 - TRUSS HEAD MACHINE SCREW, STAINLESS, M4x6
- B1 - HEXAGON BOLT AND SPRING WASHER + PLAIN WASHER ASSY, STAINLESS, M5x12

MODEL		CONDENSER UNIT	TITLE						
		<b>S-0387, 0387-1</b>	<b>N. CONDENSER UNIT</b>						
INDEX NO.	DESCRIPTION	MATERIAL OR MODEL NUMBER	PART NUMBER	REQ'D NUMBER					
				E-1	F-1	G-1	H-0	J-0	
1	Frame - Unit	G.S	208239G02	1	1	1	1	1	
2	Condenser - Air-cooled	-	206032-01	1	1	1	1	1	
3	Shroud	G.S	209813-01	1	1	1	1	1	
4	Condensing Pressure Regulator	DAC-RY333-HD	425597-01	1	1	1	1	1	
5	Coupling (Male)	5782-6-6	<a href="#">426554-01</a>	2	2	2	2	2	
6	Strap	G.S	416877-01	2	2	2	2	2	
7	Fan Motor	IJ30067	2U0048-01	1	1	1	1	1	
8	Fan Blade	Aluminum	425313-01	1	1	1	1	1	
9	Bracket - Pan Motor	G.S	315737-02	1	1	-			
			320478-02			1	1	1	
10	Cover - Leads, Fan Motor	G.S	425552-02	1	1	1	1	1	
11	Bushing	SB-625-8	<a href="#">420470-01</a>	2	2	2	2	2	
12	Junction Box	No. 6001	421587-01	1	1	1	1	1	
13	Bushing	SR-4K-4	420472-01	1	1	1	1	1	
14	Capacitor - Fan Motor	440VAC, 1.5 $\mu$ F	425309-01	1	1	1	1	1	
15	Strap	G.S	425553-01	1	1	1	1	1	
16	Cover - Box	G.S	421668-01	1	1	1	1	1	
17	Label - Arrow, "Out"	PETP Film	420743-01	1	1	1	1	1	
18	Label - Arrow, "In"	PETP Film	420743-02	1	1	1	1	1	
19	Bracket	G.S	419211-01	2	2	2	2	2	
20	Side Panel - Unit	G.S	311435-01	1	1	1	1	1	
21	Side Panel (Left) - Unit	G.S	315963-01	1	1	1	1	1	
22	Cover	G.S	421669-01	1	1	1	1	1	
23	Guard	G.S	313083G01	1	1	1	1	1	
24	Roof - Unit	G.S	311438G02	2	2	2	2	2	
25	Bracket - Roof	G.S	419219-01	2	2	2	2	2	
26	Top Panel - Unit	G.S	311436-02	1	1	1	1	1	
27	Nameplate	PES Film	428626-01	1	1	1	1	-	
			435961-01					1	
28	Instruction Sheet	Paper	208245-01	1	1	1	1	1	
	- Inst. Cond.								
29	Label - Factory Adjusted	PETP Film	419404-01	1	1	1	1	1	
30	Tag - Fan Motor Leads	Paper	420742-01	1	1	1	1	1	
31	Pipe - Inlet	Copper	318641G01	1	1	1	1	1	



MODEL CONDENSER UNIT		TITLE						
S-0387-1		N. CONDENSER UNIT						
INDEX NO.	DESCRIPTION	MATERIAL OR MODEL NUMBER	PART NUMBER	REQ'D NUMBER				
				J-1				
1	Frame - Unit	G.S	208239G02	1				
2	Condenser - Air-cooled	-	206032-01	1				
3	Shroud	G.S	209813-01	1				
4	Condensing Pressure Regulator	DAC-RY333-HD	425597-01	-				
		DBC-Y30-HD-1	428637-01	1				
5	Coupling (Male)	5782-6-6	426554-01	2				
6	Strap	G.S	416877-01	2				
7	Fan Motor	IJ30067	2U0048-01	1				
8	Fan Blade	Aluminum	425313-01	1				
9	Bracket - Fan Motor	G.S	320478-02	1				
10	Cover - Leads, Fan Motor	G.S	425552-01	1				
11	Bushing	SB-625-8	420470-01	2				
12	Junction Box	No.6001	421587-01	1				
13	Bushing	SR-4K-4	420472-01	1				
14	Capacitor - Fan Motor	440VAC, 1.5 UF	425309-01	1				
15	Strap	G.S	425553-01	1				
16	Cover - Box	G.S	421668-01	1				
17	Label - Arrow, "Out"	PETP Film	420743-01	1				
18	Label - Arrow, "In"	PETP Film	420743-02	1				
19	Bracket	G.S	419211-01	2				
20	Side Panel - Unit	G.S	311435-01	1				
21	Side Panel (Left) - Unit	G.S	315963-01	1				
22	Cover	G.S	421669-01	1				
23	Guard	G.S	313083G01	1				
24	Roof - Unit	G.S	311438G02	2				
25	Bracket - Roof	G.S	419219-01	2				
26	Top Panel - Unit	G.S	311436-02	1				
27	Nameplate	PES Film	435961-01	1				
28	Instruction Sheet	Paper	208245-01	1				
	- Inst. Cond.							
29	Label - Factory Adjusted	PETP Film	419404-01	1				
30	Tag - Fan Motor Leads	Paper	420742-01	1				
31	Pipe - Inlet	Copper	318641G01	-				
			320227G02	1				

MODEL		CONDENSER UNIT	TITLE					
		S-0387, 0387-1	N. CONDENSER UNIT					
INDEX NO.	DESCRIPTION	MATERIAL OR MODEL NUMBER	PART NUMBER	REQ'D NUMBER				
				E-1	F-1	G-1	H-0	J-0
32	Pipe	Copper	427485-01	1	1	1	1	1
33	Pipe - Outlet	Copper	427486-01	1	1	1	1	1
34	Support - Roof	G.S	311442-02	4	4	4	4	4

MODEL		CONDENSER UNIT	TITLE					
		S-0387-1	N. CONDENSER UNIT					
INDEX NO.	DESCRIPTION	MATERIAL OR MODEL NUMBER	PART NUMBER	REQ'D NUMBER				
				J-1				
32	Pipe	Copper	427485-01	-				
			431142-01	1				
33	Pipe - Outlet	Copper	427486-01	-				
			431143-02	1				
34	Support - Roof	G.S	311442-02	4				

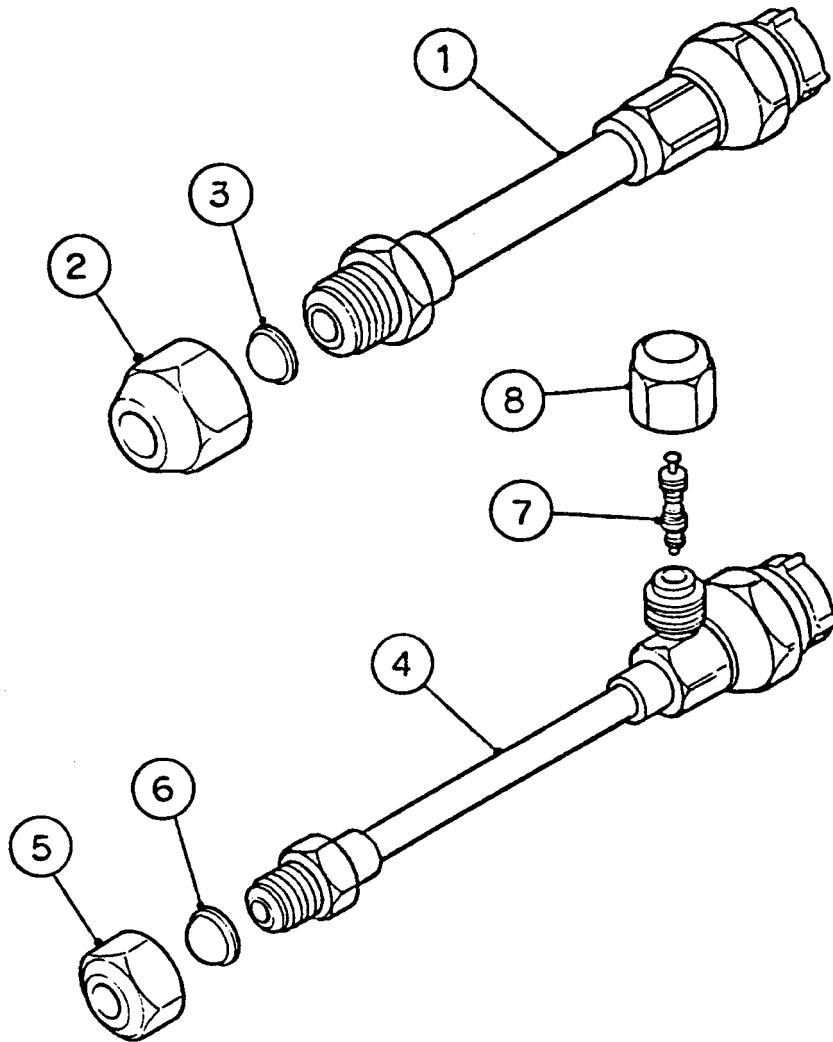

MODEL CONDENSER UNIT TITLE

**S-0387,0387-1**

**P. ACCESSORIES**

INDEX NO.	DESCRIPTION	MATERIAL OR MODEL NUMBER	PART NUMBER	REQ'D NUMBER				
				E-1	F-1	G-1	H-0	J-0
1	Coupling (Female)	(S-0371)	421674G01	1	1	1	1	1
2	Flare Nut	421678A01	403695-01	1	1	1	1	1
3	Cap - Flared	1220P	418295-02	1	1	1	1	1
4	Coupling (Female)	-	421673G01	1	1	1	1	1
5	Flare Nut	(S-0373)	419177-01	1	1	1	1	1
6	Cap - Flared	421677A01	418295-01	1	1	1	1	1
7	Valve Core	222034-4	421671-01	1	1	1	1	1
8	Cap	221014-4B	421672-01	1	1	1	1	1

MODEL		CONDENSER UNIT	TITLE					
		S-0387-1	P. ACCESSORIES					
INDEX NO.	DESCRIPTION	MATERIAL OR MODEL NUMBER	PART NUMBER	REQ'D NUMBER				
				J-1				
1	Coupling (Female)	(S-0371)	421674G01	1				
2	Flare Nut	421678A01	403695-01	1				
3	Cap - Flared	1220P	418295-02	1				
4	Coupling (Female)	-	421673G01	1				
5	Flare Nut	(S-0373)	419177-01	1				
6	Cap - Flared	421677A01	418295-01	1				
7	Valve Core	222034-4	421671-01	1				
8	Cap	221014-4B	421672-01	1				