



**HOSHIZAKI**

**MODULAR FLAKER**

**MODEL**

**F-1101AU**

**PARTS LIST**

---

ISSUED: JUL. 1, 1985

---

REVISED: APR. 19, 1989

---

PRINTED: DEC. 10, 1994

---

ITEM NO: 71037

---

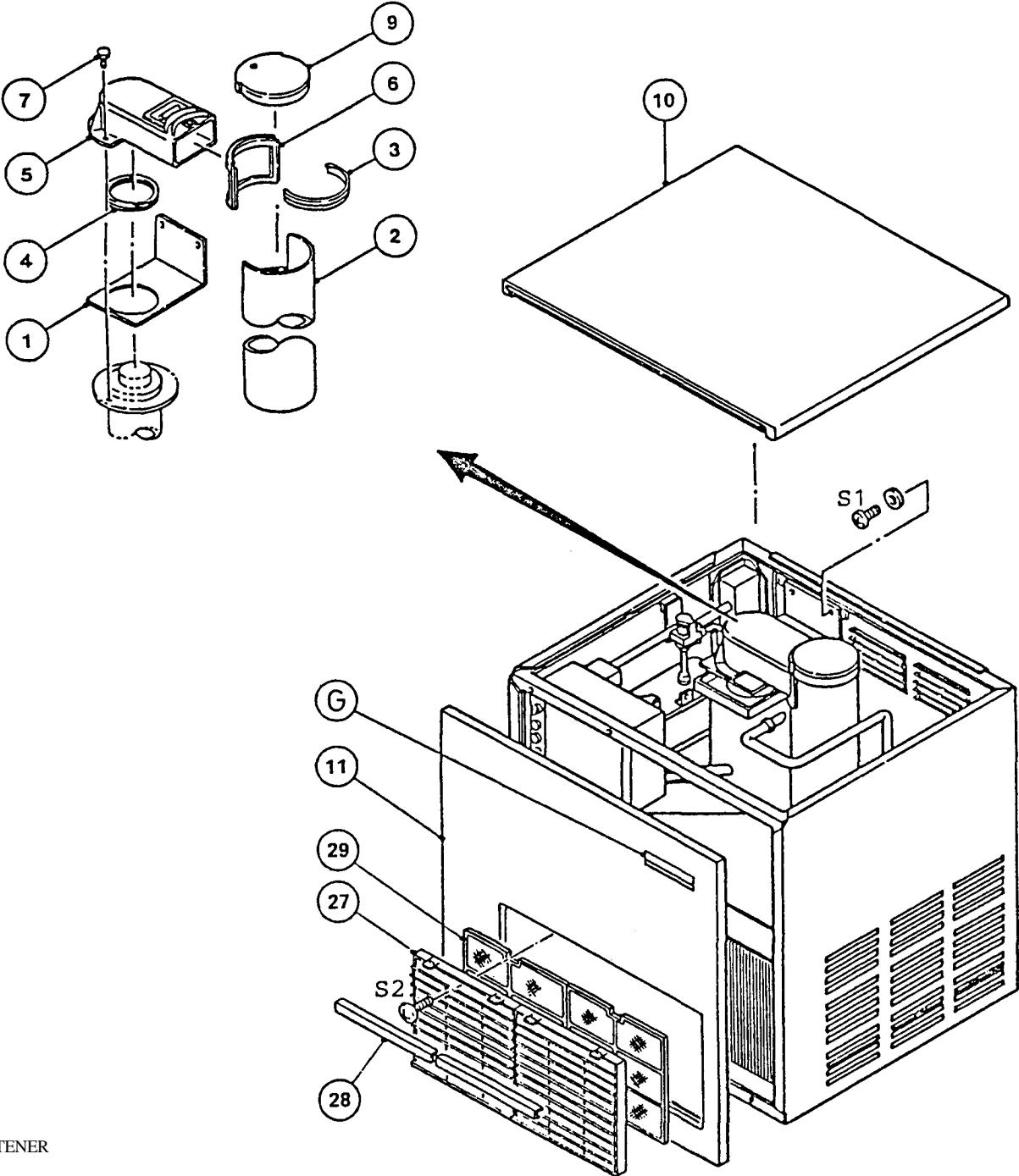

FASTENER

- S1 - TRUSS HEAD MACHINE SCREW, STAINLESS, M5x12
- S2 - TRUSS HEAD TAPPING SCREW, M4x8

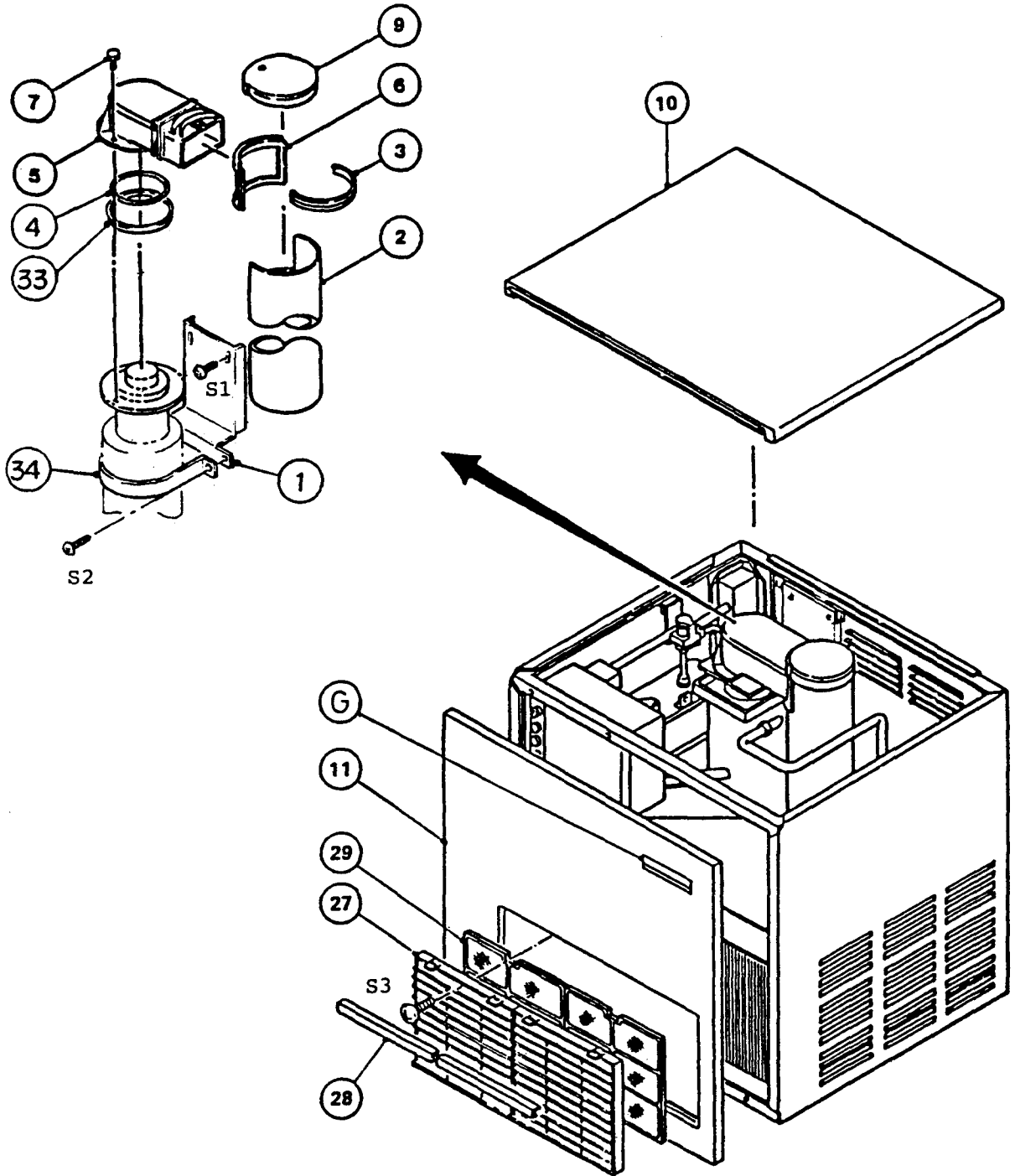

FASTENER

- S1 - TRUSS HEAD MACHINE SCREW. STAINLESS, M5x12
- S2 - TRUSS HEAD MACHINE SCREW, M4x8
- S3 - TRUSS HEAD TAPPING SCREW. M4x8

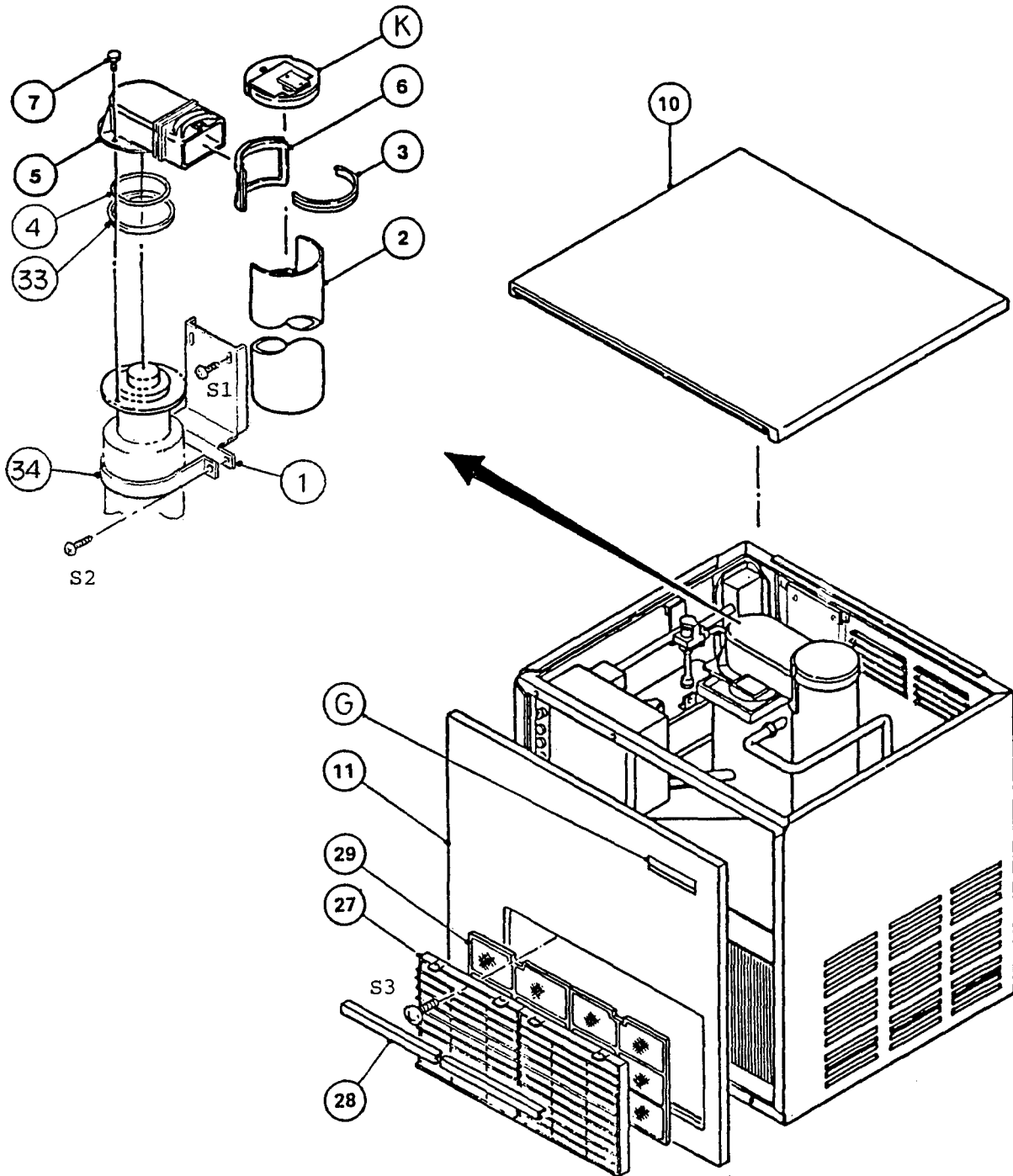

FASTENER

- S1 - TRUSS HEAD MACHINE SCREW, STAINLESS, M5x12
- S2 - TRUSS HEAD MACHINE SCREW, M4x8
- S3 - TRUSS HEAD TAPPING SCREW, M4x8

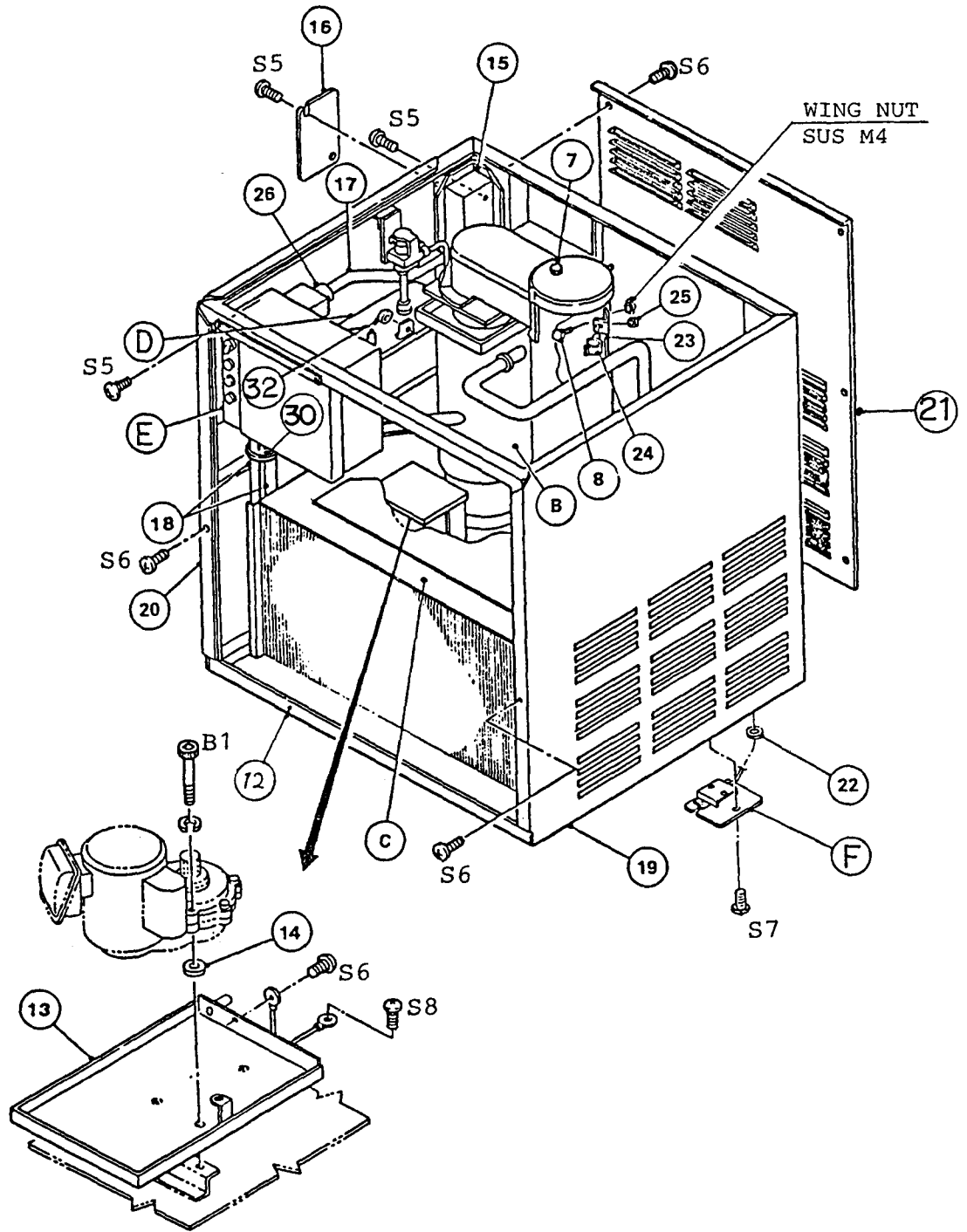

FASTENER

- S5 - TRUSS HEAD MACHINE SCREW, M4x8
- S6 - TRUSS HEAD MACHINE SCREW, STAINLESS, M4x6
- S7 - TRUSS HEAD MACHINE SCREW, STAINLESS, M4x8
- S8 - TRUSS HEAD MACHINE SCREW, M4x6
- B1 - HEXAGON SOCKET CAP BOLT, STAINLESS, M8x90

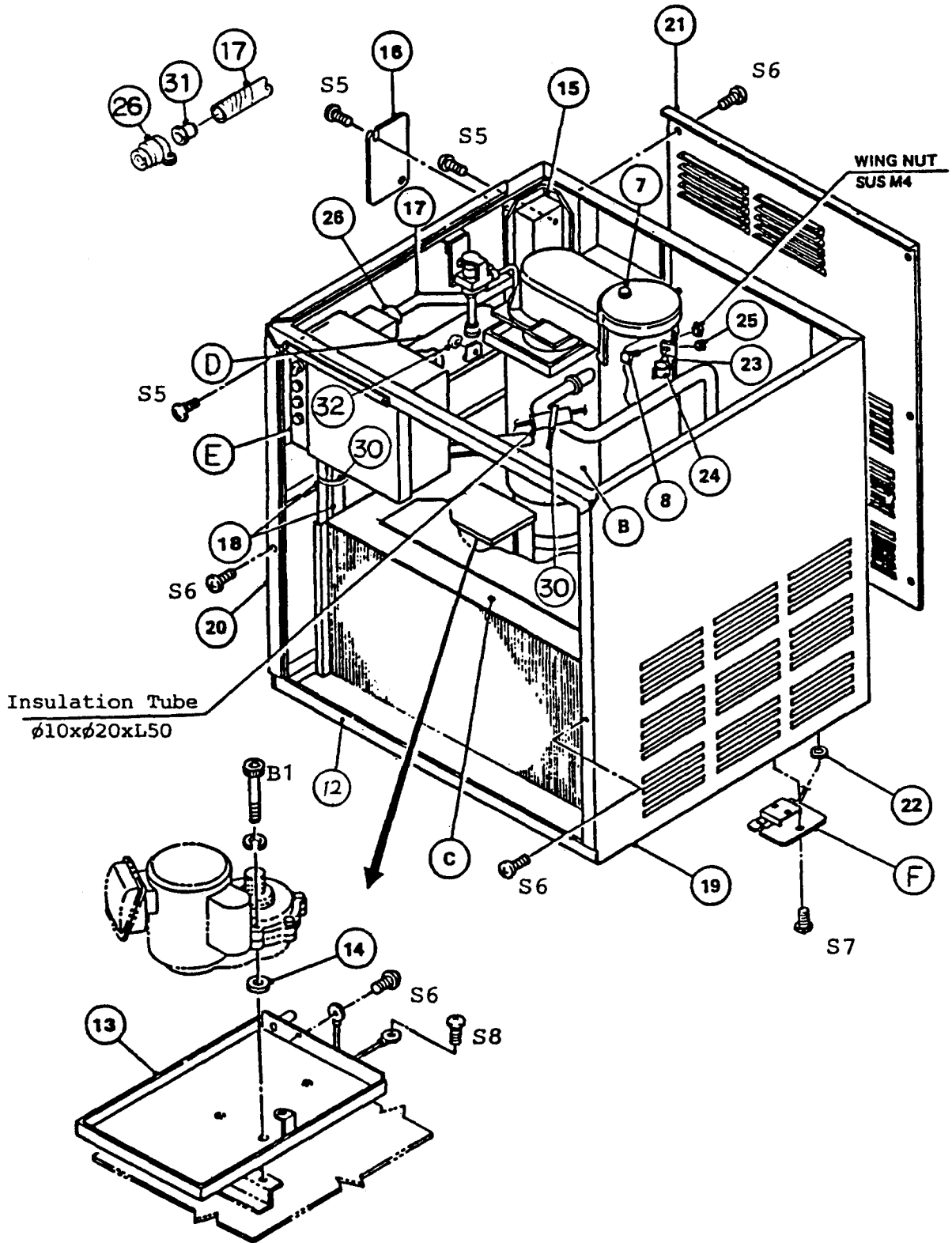

FASTENER

- S5 - TRUSS HEAD MACHINE SCREW, M4x8
- S6 - TRUSS HEAD MACHINE SCREW, STAINLESS. M4x6
- S7 - TRUSS HEAD MACHINE SCREW, STAINLESS, M4x8
- S8 - TRUSS HEAD MACHINE SCREW, M4x6
- B1 - HEXAGON SOCKET CAP BOLT, STAINLESS, M8x90

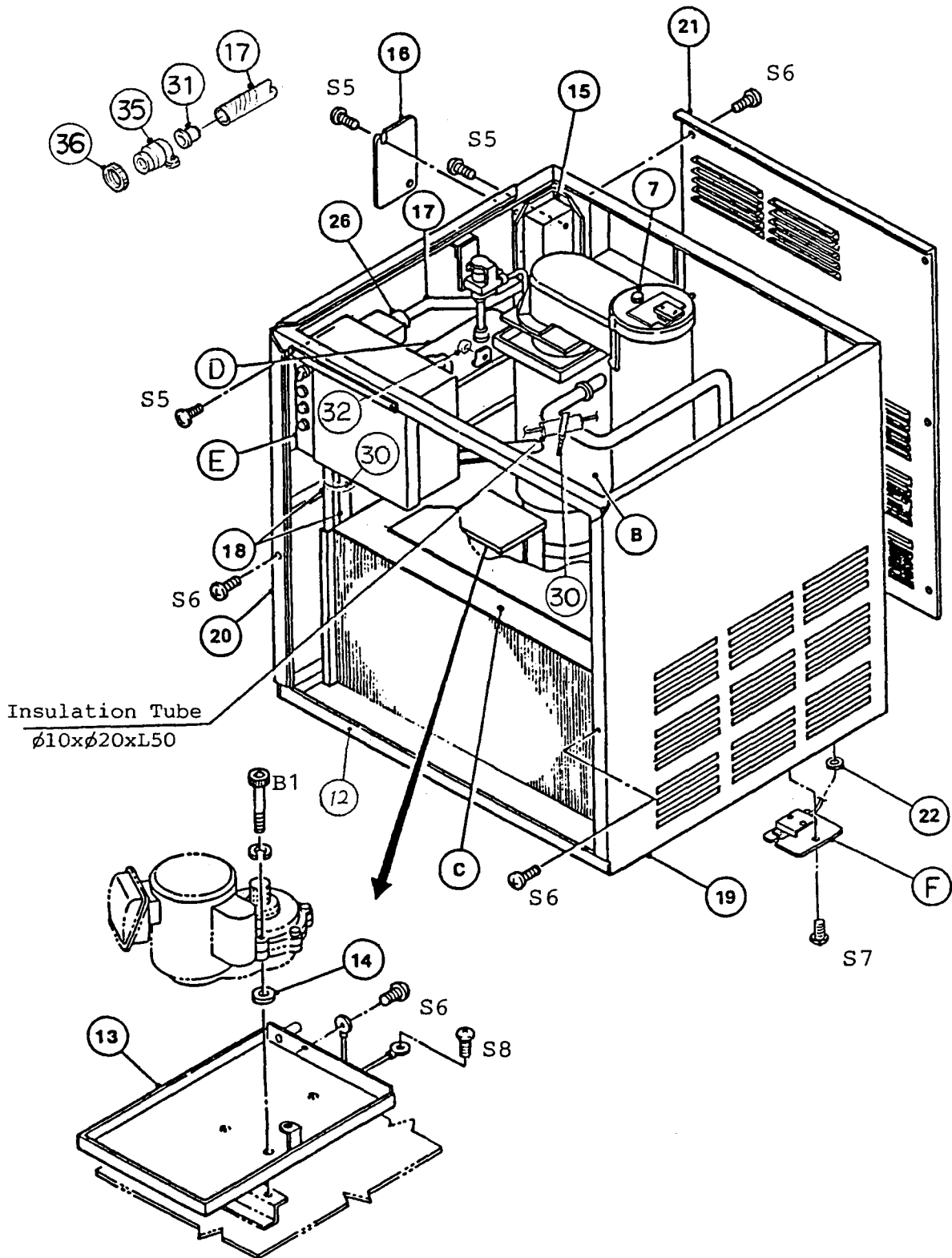

FAS

- S5 - TRUSS HEAD MACHINE SCREW, M4x8
- S6 - TRUSS HEAD MACHINE SCREW, STAINLESS, M4x6
- S7 - TRUSS HEAD MACHINE SCREW, STAINLESS, M4x8
- S8 - TRUSS HEAD MACHINE SCREW, M4x6
- B1 - HEXAGON SOCKET CAP BOLT, STAINLESS, M8x90

MODEL F-1101AU		TITLE A. GENERAL ASSEMBLY						
INDEX NO.	DESCRIPTION	MATERIAL OR MODEL NUMBER	PART NUMBER	REQ'D NUMBER				
				E-1	F-1	F-2	G-1	G-2
B	EVAPORATOR ASSEMBLY	-	208112A04	1	-			
			319958A03		1	1	1	1
C	REFRIGERATION UNIT	-	103069A02	1	1	1	1	1
D	MATER CIRCUIT ASSEMBLY	-	103078A02	1	-			
			103078A03		1	1	1	1
E	CONTROL BOX ASSEMBLY	-	315764A03	1	1	-		
			315764A04			1	1	1
F	BIN SWITCH ASSEMBLY	-	317649A01	1	1	1	1	1
G	LABEL LOCATION	-	315762A05	1	1	1	1	-
			315762A06					1
1	Bracket - Evaporator	S.S	425251-01	1	1	1		
		G.S	431735-01				1	1
2	Chute	PE	318613-01	1	1	1	-	
			320555-01				1	1
3	Packing - Chute	EPDM	<a href="#">425255-01</a>	1	1	1	1	1
4	Packing - Cylinder	EPDM	<a href="#">427151-03</a>	1	1	1	-	
	"O" Ring	G95	<a href="#">7616-G095</a>				1	1
5	Spout	ABS	103382G01	1	1	1	-	
		PC	<a href="#">103932G01</a>				1	1
6	Packing - Spout	EPDM	315722-01	1	1	1	1	1
7	Thumbscrew	S.S, ABS	<a href="#">415949G03</a>	4	4	4	4	4
8	Thumbscrew	S.S, ABS	415949G04	2	2	2	2	2
9	Cover - Chute	ABS	209817G01	1	1	1	1	1
10	Top Panel	S.S	315750G01	1	1	1	1	1
11	Front Panel	S.S	317189-01	1	1	1	-	
			317189-02				1	1
12	Frame	G.S	315778G04	1	1	1	1	1
13	Drip Pan	S.S	317168G01	1	1	1	1	1
14	Washer	PVC	422916-01	3	3	3	3	3
15	Junction Box	No. 6001	421587-01	1	1	1	1	1
16	Cover - Junction Box	G.S	420594-01	1	1	1	1	1
17	Conduit	-	429313-02	1	1	1	1	1
18	Conduit	-	429313-01	2	2	2	2	2
19	Side Panel (Right)	S.S	318332G01	1	1	1	1	1



MODEL F-1101AU		TITLE A. GENERAL ASSEMBLY							
INDEX NO.	DESCRIPTION	MATERIAL OR MODEL NUMBER	PART NUMBER	REQ'D NUMBER					
				H-0	J-1	J-2			
B	EVAPORATOR ASSEMBLY	-	319958A03	1	1	1			
C	REFRIGERATION UNIT	-	103069A02	1	1	-			
			103069A03			1			
D	MATER CIRCUIT ASSEMBLY	-	103078A03	1	1	1			
E	CONTROL BOX ASSEMBLY	-	315764A04	1	-				
			213117A02		1	1			
F	BIN SWITCH ASSEMBLY	-	317649A01	1	1	1			
G	LABEL LOCATION	-	315762A06	1	-				
			213149A02		1	1			
K	SPOUT CONTROL ASSEMBLY	-	323313A01		1	1			
1	Bracket - Evaporator	G.S	431735-01	1	1	1			
2	Chute	PE	320555-01	1	-				
			315723-01		1	1			
3	Packing - Chute	EPDM	425255-01	1	1	1			
4	"O" Ring	G95	7616-G095	1	1	1			
5	Spout	PC	103932G01	1	1	1			
6	Packing - Spout	EPDM	315722-01	1	1	1			
7	Thumbscrew	S.S, ABS	415949G03	4	4	4			
8	Thumbscrew	S.S, ABS	415949G04	2	-				
9	Cover - Chute	ABS	209817G01	1	-				
10	Top Panel	S.S	315750G01	1	1	1			
11	Front Panel	S.S	317189-02	1	1	1			
12	Frame	G.S	315778G04	1	-				
			315778G07		1	1			
13	Drip Pan	S.S	317168G01	1	1	1			
14	Washer	PVC	422916-01	3	3	3			
15	Junction Box	No. 6001	421587-01	1	1	1			
16	Cover - Junction Box	G.S	420594-01	1	1	1			
17	Conduit	-	429313-02	1	1	1			
18	Conduit	-	429313-01	2	2	2			
19	Side Panel (Right)	S.S	318332G01	1	1	1			

MODEL F-1101AU		TITLE A. GENERAL ASSEMBLY						
INDEX NO.	DESCRIPTION	MATERIAL OR MODEL NUMBER	PART NUMBER	REQ'D NUMBER				
				E-1	F-1	F-2	G-1	G-2
20	Side Panel (Left)	S.S	315748G02	1	1	1	1	1
21	Rear Panel	S.S	318331G01	1	1	1	1	1
22	Bushing	SB-437-5	<a href="#">420470-07</a>	1	1	1	1	1
23	Bracket - Thermostat	S.S	318612-01	1	1	1	1	1
24	Clip	PA No. 96	429285-01	2	2	2	2	2
25	Bushing - Capillary Tube	EPDM	<a href="#">425307-01</a>	1	1	1	1	1
26	Fitting - Conduit Stright	No. 13-16	425316-01	6	6	6	6	6
27	Louver (B)	ABS	103121-01	2	2	2	2	2
28	Cover - Louver (B)	ABS	316079-01	2	2	2	2	2
29	Air Filter (B)	ABS	208283G01	2	2	2	2	2
30	Tie	CV-150	7920-0003	1	1	1	1	1
31	Collar	Steel	430335-01		6	6	6	6
32	Bushing	SR-30-1	<a href="#">420472-03</a>	1	1	1	1	1
33	Ring	PA	<a href="#">431736-01</a>				1	1
34	Strap	G.S	<a href="#">431737-01</a>				1	1

MODEL F-1101AU		TITLE A. GENERAL ASSEMBLY							
INDEX NO.	DESCRIPTION	MATERIAL OR MODEL NUMBER	PART NUMBER	REQ'D NUMBER					
				H-0	J-1				
20	Side Panel (Left)	S.S	315748G02	1	1				
21	Rear Panel	S.S	318331G01	1	1				
22	Bushing	SB-437-5	<a href="#">420470-07</a>	1	1				
23	Bracket - Thermostat	S.S	318612-01	1	-				
24	Clip	PA No. 96	429285-01	2	-				
25	Bushing - Capillary Tube	EPDM	<a href="#">425307-01</a>	1	-				
26	Pitting - Conduit Stright	No.13-16	425316-01	6	-				
27	Louver (B)	ABS	103121-01	2	2				
28	Cover - Louver (B)	ABS	316079-01	2	2				
29	Air Filter (B)	ABS	208283G01	2	2				
30	Tie	CV-150	7920-0003	2	2				
31	Collar	Steel	430335-01	6	6				
32	Bushing	SR-30-1	<a href="#">420472-03</a>	1	1				
33	Ring	PA	<a href="#">431736-01</a>	1	1				
34	Strap	G.S	<a href="#">431737-01</a>	1	1				
35	Fitting - Conduit	NS-1621	435753-01		6				
36	Nut	t3.6	435753F01		6				

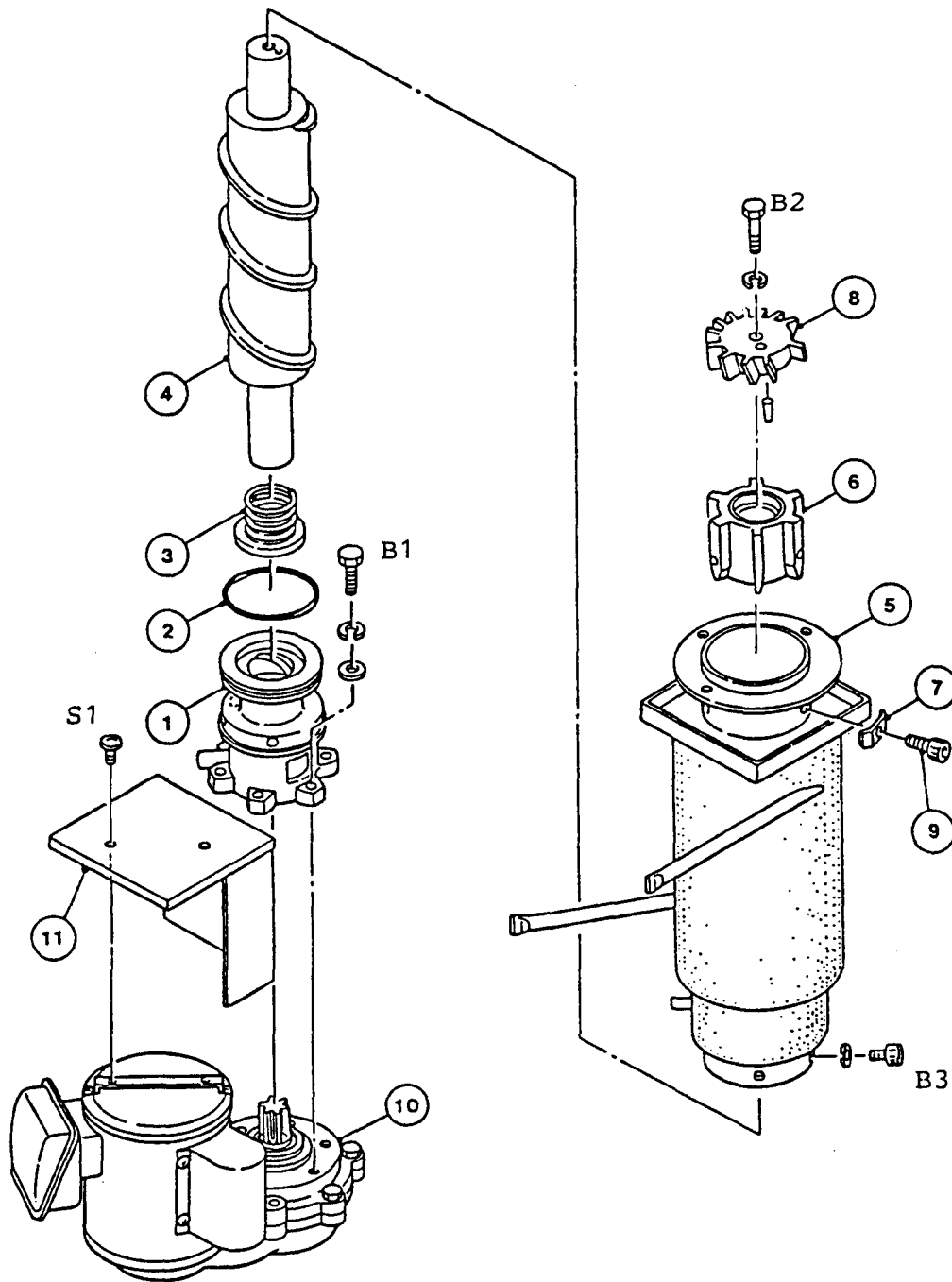

FASTENER

- S1 - TRUSS HEAD MACHINE SCREW, M4x8
- B1 - HEXAGON HEAD BOLT, STAINLESS, M8x30
- B2 - HEXAGON HEAD BOLT, STAINLESS, M1 0x 30
- B3 - HEXAGON SOCKET CAP BOLT, STAINLESS, M10x20

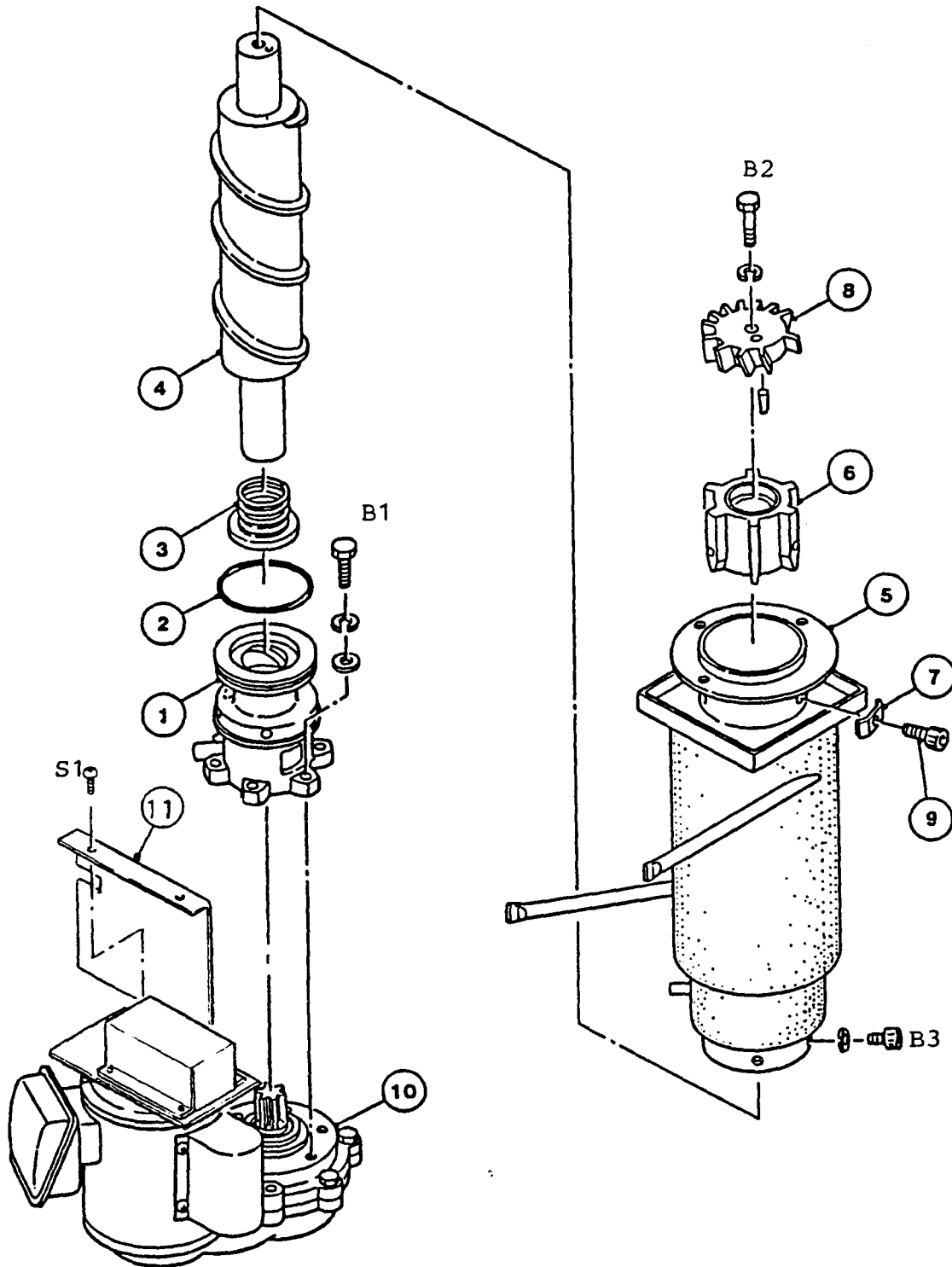

FASTENER

- S1 - TRUSS HEAD MACHINE SCREW. M4x8
- B1 - HEXAGON HEAD BOLT, STAINLESS. M8x30
- B2 - HEXAGON HEAD BOLT, STAINLESS, M10x40
- B3 - HEXAGON SOCKET CAP BOLT, STAINLESS, M10x20

MODEL F-1101AU		TITLE B. EVAPORATOR ASSEMBLY						
INDEX NO.	DESCRIPTION	MATERIAL OR MODEL NUMBER	PART NUMBER	REQ'D NUMBER				
				E-1	F-1	F-2	G-1	G-2
1	Bearing (Lower)	-	<a href="#">315732G02</a>	1	1	1	1	1
2	"O" Ring	G90	<a href="#">7616-G090</a>	1	1	1	1	1
3	Mechanical Seal	HG9A-MN	<a href="#">420692-01</a>	1	1	1	1	-
		HK9A-MN	<a href="#">432493-01</a>					1
4	Auger	S.S	209744G01	1	1	1	-	
			<a href="#">211062G01</a>				1	1
5	Evaporator	-	425273G04	1	1	1	1	1
6	Extruding Head	S.S	<a href="#">208117G02</a>	1	1	1	1	1
7	Hasher	S.S	<a href="#">425277-01</a>	3	3	3	3	3
8	Cutter	S.S	315734-01	1	1	1	1	1
9	Socket Head Cap Screw	S.S, M10	<a href="#">429121-02</a>	3	3	3	3	3
10	Gear Motor	MGZ2200UL-160	2U0044-01	1	-			
			432068-01		1	1	1	1
11	Cover - Gear Motor	G.S	315841G01	1	-			
			431532-01		1	1	1	1

MODEL F-1101AU		TITLE B. EVAPORATOR ASSEMBLY						
INDEX NO.	DESCRIPTION	MATERIAL OR MODEL NUMBER	PART NUMBER	REQ'D NUMBER				
				H-0	J-1			
1	Bearing (Lower)	-	315732G02	1	1			
2	"O" Ring	G90	7616-G090	1	1			
3	Mechanical Seal	HK9A-MN	432493-01	1	1			
4	Auger	S.S	211062G01	1	1			
5	Evaporator	-	425273G04	1	1			
6	Extruding Head	S.S	208117G02	1	1			
7	Washer	S.S	425277-01	3	3			
8	Cutter	S.S	315734-01	1	1			
9	Socket Head Cap Screw	S.S, M10	429121-02	3	3			
10	Gear Motor	MGZ2200UL-160	432068-01	1	1			
11	Cover - Gear Motor	G.S	431532-01	1	1			

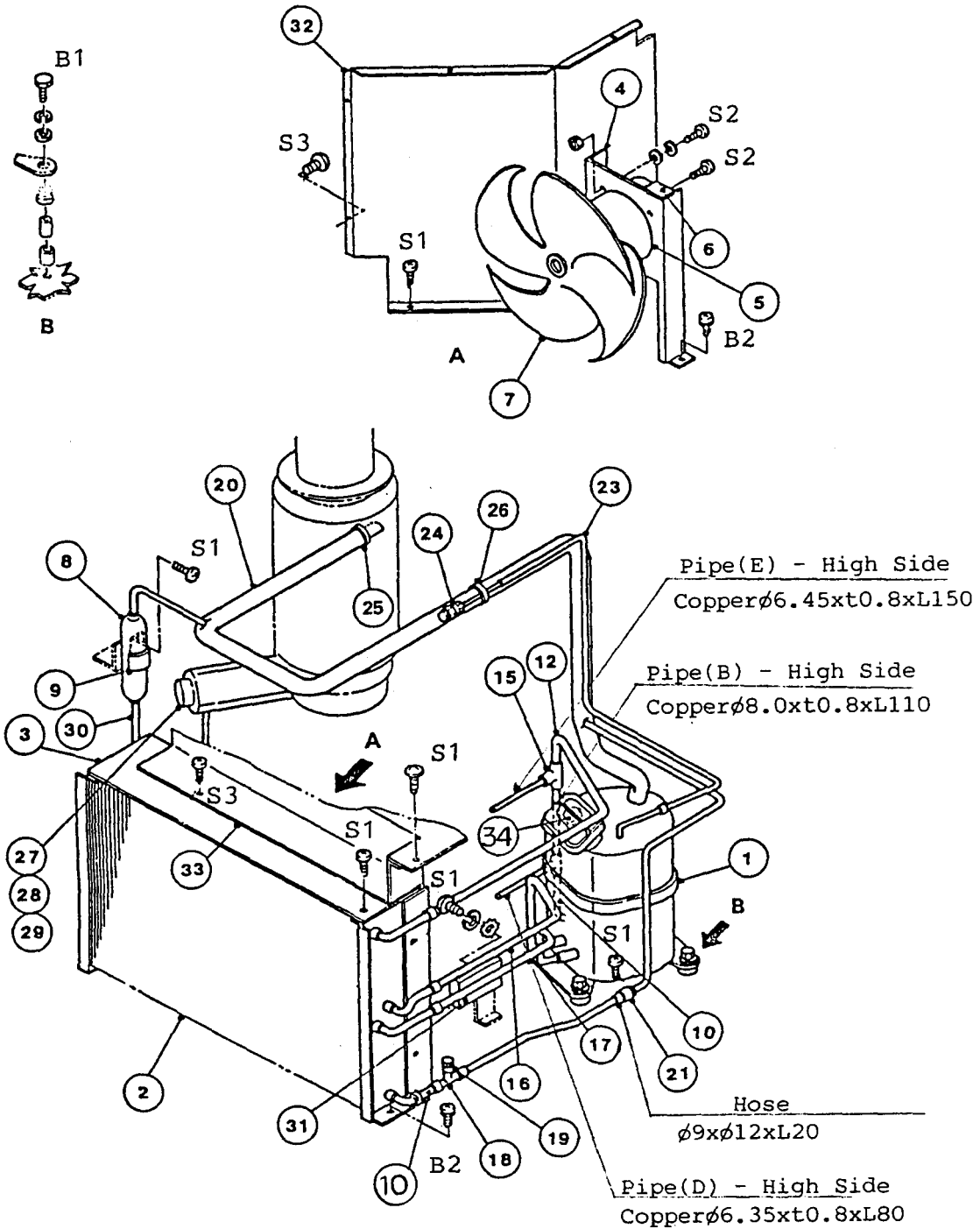

FASTENER

- S1 - TRUSS HEAD MACHINE SCREW, M4x8
- S2 - TRUSS HEAD MACHINE SCREW, M4x12
- S3 - TRUSS HEAD TAPPING SCREW, M4x8
- B1 - HEXAGON HEAD BOLT, M8x45
- B2 - HEXAGON BOLT AND SPRING WASHER + PLAIN WASHER ASSY, M5x12



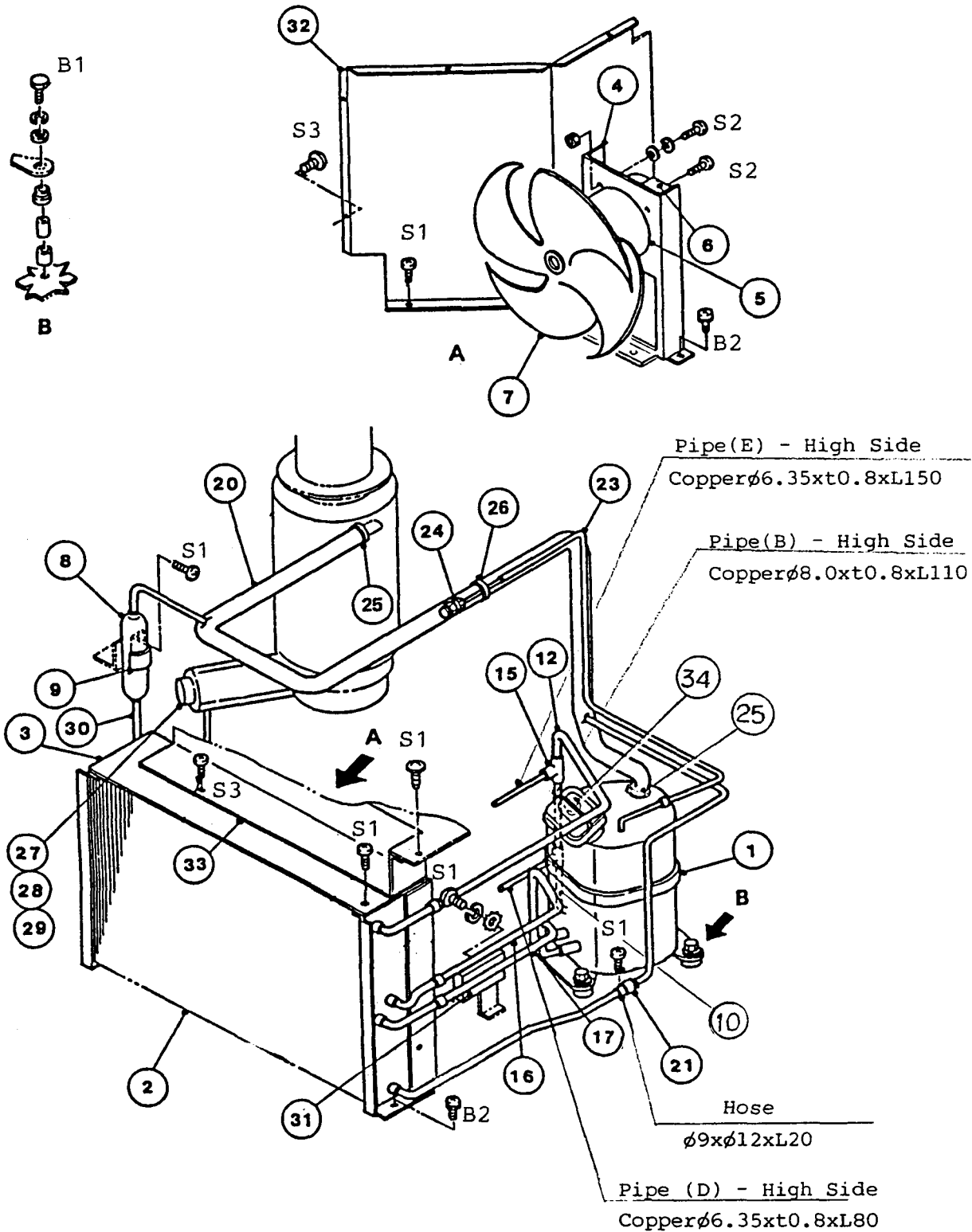

FASTENER

- S1 - TRUSS HEAD MACHINE SCREW, M4x8
- S2 - TRUSS HEAD MACHINE SCREW, M4x12
- S3 - TRUSS HEAD TAPPING SCREW, M4x8
- B1 - HEXAGON HEAD BOLT, M8x45
- B2 - HEXAGON BOLT AND SPRING WASHER + PLAIN WASHER ASSY, M5x12

MODEL F-1101AU		TITLE C. REFRIGERATION UNIT			REQ'D NUMBER				
INDEX NO.	DESCRIPTION	MATERIAL OR MODEL NUMBER	PART NUMBER	E-1	F-1	F-2	G-1	G-2	
				1	Compressor	KL100TD-3	2U0043-01	1	1
2	Condenser - Air-cooled	-	2U0074-01	1	1	1	1	1	
3	Shroud	G.S	209568-01	1	1	1	1	1	
4	Bracket - Fan Motor	G.S	315737-01	1	1	1	-		
			<a href="#">320478-01</a>				1	1	
5	Pan Motor	IJ30067	2U0048-01	1	1	1	1	1	
6	Capacitor - Fan Motor	440VAC, 1.5 $\mu$ F	425309-01	1	1	1	1	1	
7	Fan Blade	Aluminum	425313-01	1	1	1	1	1	
8	Drier	DYN-2-HD-1	418498-01	1	1	1	1	1	
9	Strap	G.S	425280-01	1	1	1	1	1	
10	Pipe (A) - High Side	Copper	425281-01	2	1	1	1	1	
11	-	-	-	-					
12	Pipe (C) - High Side	Copper	425282-01	1	1	1	1	1	
13	-	-	-	-					
14	-	-	-	-					
15	Tee	Copper	420041-02	2	2	2	2	2	
16	Pipe - Oil Cooler	Copper	425283-03	1	1	1	1	1	
17	Pipe - Oil Cooler	Copper	425283-04	1	1	1	1	1	
18	Tee - Fusible Plug	YWP-251-HD	421832-01	1	-				
19	Fusible Plug	FUP-1105H12	<a href="#">4U0010-01</a>	1	-				
20	Pipe - Low Side	Copper	315738G01	1	1	1	1	1	
21	Strap	G.S	416877-01	1	1	1	1	1	
22	-	-	-	-					
23	Process Tube	Copper	425284-01	1	1	1	1	1	
24	Access Valve	TCJ-2F15-HD	417366-01	1	1	1	1	1	
25	Tie	CV-100	7920-0002	2	2	2	2	2	
26	Tie	CV-150	7920-0003	1	1	1	1	1	
27	Expansion Valve	HYP2-5HD4	411518-04	1	1	1	1	1	
28	Cover (A) - Expansion Valve	PE Foam	315741-01	1	1	1	1	1	
29	Cover (B) - Expansion Valve	PE Foam	315741-02	1	1	1	1	1	
30	Pipe (G) - High Side	Copper	425286-01	1	1	1	1	1	
31	Pressure Switch	SNS-2C130YB3	<a href="#">425679-01</a>	1	1	1	1	1	

MODEL F-1101AU		TITLE C. REFRIGERATION UNIT					
INDEX NO.	DESCRIPTION	MATERIAL OR MODEL NUMBER	PART NUMBER	REQ'D NUMBER			
				H-0	J-1	J-2	
1	Compressor	KL100TD-3	2U0043-01	1	1	1	
2	Condenser - Air-cooled	-	21)0074-01	1	1	1	
3	Shroud	G.S	209568-01	1	1	1	
4	Bracket - Fan Motor	G.S	<a href="#">320478-01</a>	1	1	1	
5	Fan Motor	IJ30067	2U0048-01	1	1	1	
6	Capacitor - Fan Motor	440VAC, 1.5 $\mu$ F	425309-01	1	1	1	
7	Fan Blade	Aluminum	425313-01	1	1	1	
8	Drier	DYN-2-HD-1	418498-01	1	1	-	
		KC-6749	427061-01			1	
9	Strap	G.S	425280-01	1	1	-	
			425280-02			1	
10	Pipe (A) - High Side	Copper	425281-01	2	2	2	
11	-	-	-	-			
12	Pipe (C) - High Side	Copper	425282-01	1	1	1	
13	-	-	-	-			
14	-	-	-	-			
15	Tee	Copper	420041-02	2	2	2	
16	Pipe - Oil Cooler	Copper	425283-03	1	1	1	
17	Pipe - Oil Cooler	Copper	425283-04	1	1	1	
18	-	-	-	-			
19	-	-	-	-			
20	Pipe - Low Side	Copper	315738G01	1	1	1	
21	Strap	G.S	416877-01	1	1	1	
22	-	-	-	-			
23	Process Tube	Copper	425284-01	1	1	1	
24	Access Valve	TCJ-2F15-HD	417366-01	1	1	1	
25	Tie	CV-100	7920-0002	2	2	2	
26	Tie	CV-150	7920-0003	1	1	1	
27	Expansion Valve	HYP2-5HD4	411518-04	X			
		HYP2-5HD9	<a href="#">411518-07</a>	1	1	1	
28	Cover (A) - Expansion Valve	PE Foam	315741-01	1	1	1	
29	Cover (B) - Expansion Valve	PE Foam	315741-02	1	1	1	
30	Pipe (G) - High Side	Copper	425286-01	1	1	-	
	Pipe (J) - High Side	Copper	425286-02			1	
31	Pressure Switch	SNS-2C130YQ3	<a href="#">425679-01</a>	1	1	1	

MODEL F-1101AU		TITLE C. REFRIGERATION UNIT						
INDEX NO.	DESCRIPTION	MATERIAL OR MODEL NUMBER	PART NUMBER	REQ'D NUMBER				
				E-1	F-1	F-2	G-1	G-2
32	Partition (A)	G.S	318284-01	1	1	1	1	1
33	Partition (B)	G.S	428807G01	1	1	1	1	1
34	Overload	MSH16AIU	429382-01		1	1	1	1

MODEL F-1101AU		TITLE C. REFRIGERATION UNIT						
INDEX NO.	DESCRIPTION	MATERIAL OR MODEL NUMBER	PART NUMBER	REQ'D NUMBER				
				H-0	J-1			
32	Partition (A)	G.S	318284-01	1	1			
33	Partition (B)	G.S	428807G01	1	1			
34	Overload	MSH16AIU	429382-01	1	1			

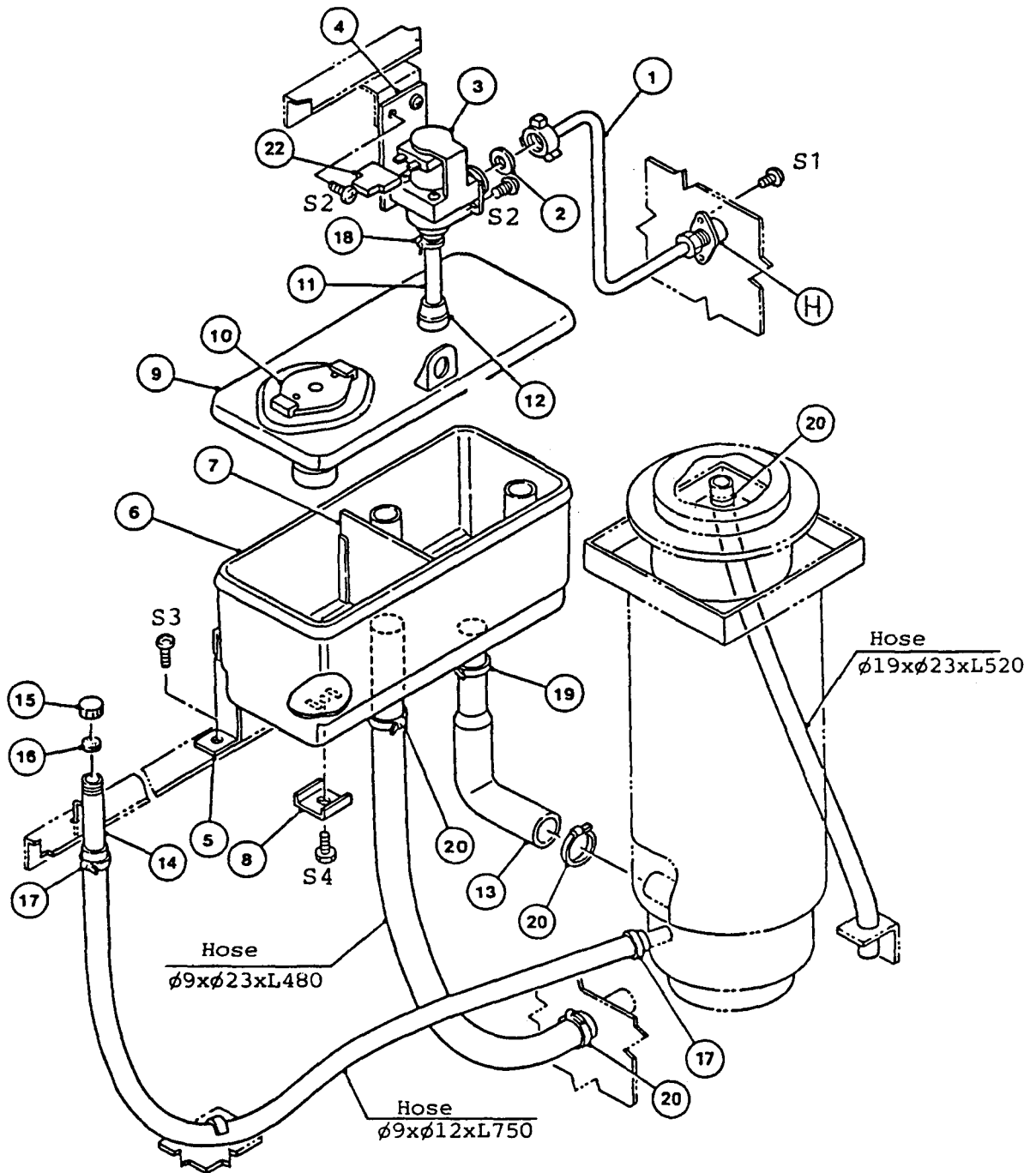

FASTENER

- S1 - TRUSS HEAD MACHINE SCREW, STAINLESS, M4x8
- S2 - TRUSS HEAD MACHINE SCREW, M4x8
- S3 - TRUSS HEAD MACHINE SCREW, STAINLESS, M5x12
- S4 - THUMBSCREW, M4x6

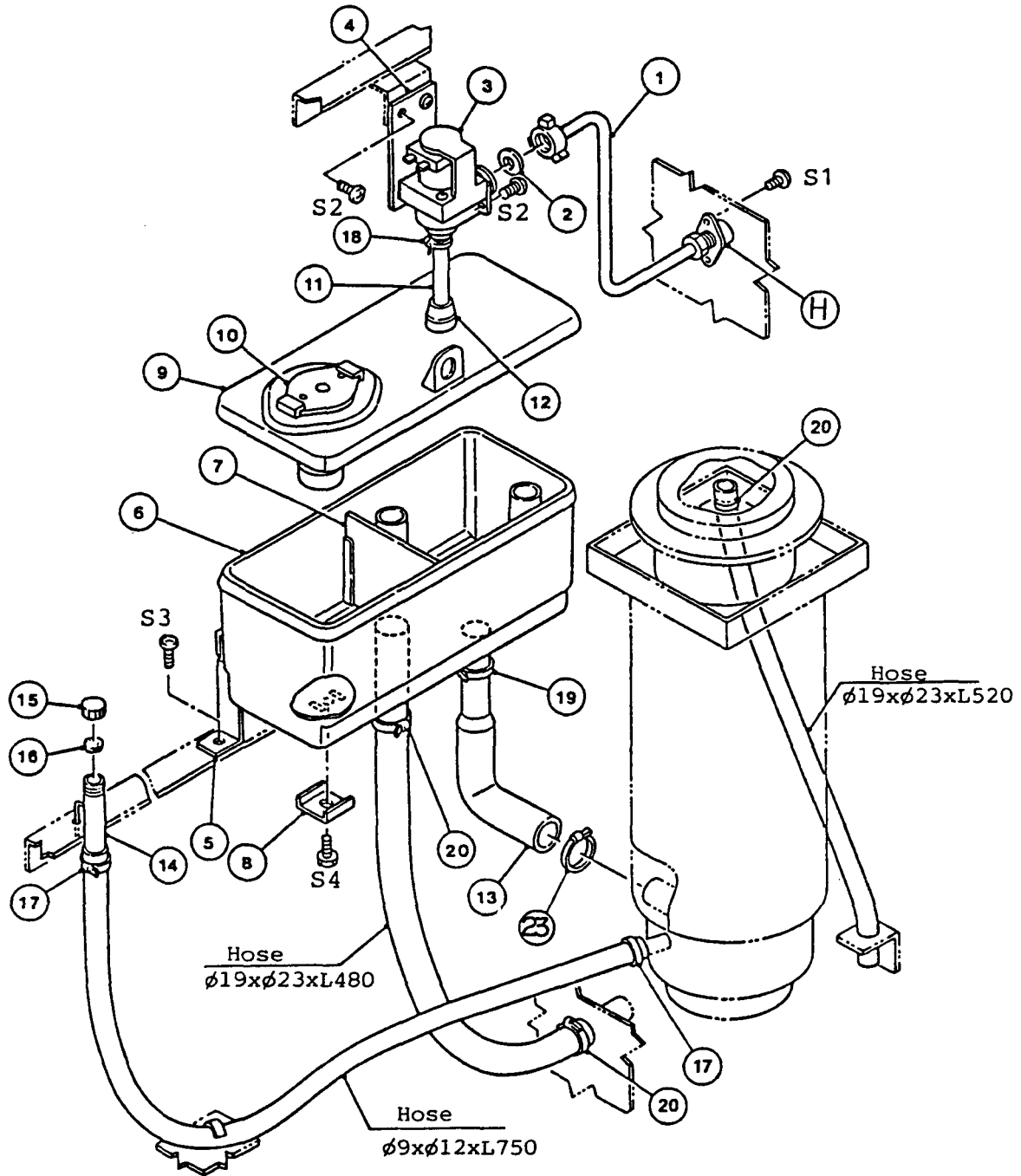

FASTENER

- S1 - TRUSS HEAD MACHINE SCREW. STAINLESS, M4x8
- S2 - TRUSS HEAD MACHINE SCREW, M4x8
- S3 - TRUSS HEAD MACHINE SCREW, STAINLESS, M5x12
- S4 - THUMBSCREW, M4x6

MODEL F-1101AU		TITLE D. WATER CIRCUIT ASSEMBLY						
INDEX NO.	DESCRIPTION	MATERIAL OR MODEL NUMBER	PART NUMBER	REQ'D NUMBER				
				E-1	F-1	F-2	G-1	G-2
H	FITTING (K) ASSEMBLY	(S-0331)	310978A01	1	1	1	1	1
1	Pipe - Water Supply	S.S	425287G01	1	1	1	1	1
2	Packing	NBR	413854-03	1	1	1	1	1
3	Water Valve	J246-086	3U0065-01	1	1	1	1	1
4	Bracket - Water Valve	G.S	425288-01	1	1	1	1	1
5	Bracket - Reservoir	G.S	315744-01	1	1	1	1	1
6	Reservoir	ABS	208125-01	1	1	1	1	1
7	Separator - Reservoir	ABS	423538-02	1	1	1	1	1
8	Collar	S.S	423416-01	1	1	1	1	1
9	Cover - Reservoir	ABS	208126-01	1	1	1	1	1
10	Float Switch	FFS-536B6IB-21	417220-01	1	1	1	1	1
11	Hose - Water Supply	EVA	425289-01	1	1	1	1	1
12	Cover - Reservoir Inlet	SI.R	415094-01	1	1	1	1	1
13	Hose - Water Supply	PP Polymer	422922-01	1	-			
		EPDM	428615-05		1	1	1	1
14	Pipe - Drain	S.S	425292G01	1	1	1	1	1
15	Cap - Drain	Brass	425293-01	1	1	1	1	1
16	Packing - Drain	Sy.R	425294-01	1	1	1	1	1
17	Clamp	MH-30N	421642-04	2	2	2	2	2
18	Clamp	MH-44N	421642-07	1	1	1	1	1
19	Clamp	MH-50N	421642-08	1	-			
		SK-183	426148-07		1	1	1	1
20	Clamp	MH-56N	421642-09	4	3	3	3	3
21	-	-	-	-	-	-	-	-
22	2-Pin Connector	J24032422	414358-01	1	-			
23	Clamp	SK-250	426148-08		1	1	1	1



MODEL F-1101AU		TITLE D. WATER CIRCUIT ASSEMBLY						
INDEX NO.	DESCRIPTION	MATERIAL OR MODEL NUMBER	PART NUMBER	REQ'D NUMBER				
				H-0	J-1	J-2		
H	FITTING (K) ASSEMBLY	(S-0331)	310978A01	1	1	1		
1	Pipe - Water Supply	S.S	425287G01	1	1	1		
2	Packing	NBR	<a href="#">413854-03</a>	1	1	1		
3	Water Valve	J246-086	<a href="#">3U0065-01</a>	1	1	1		
4	Bracket - Water Valve	G.S	425288-01	1	1	1		
5	Bracket - Reservoir	G.S	315744-01	1	1	1		
6	Reservoir	ABS	<a href="#">208125-01</a>	1	1	1		
7	Separator - Reservoir	ABS	<a href="#">423538-02</a>	1	1	1		
8	Collar	S.S	<a href="#">423416-01</a>	1	1	1		
9	Cover - Reservoir	ABS	<a href="#">208126-01</a>	1	1	1		
10	Float Switch	FPS-536B6IB-21	417220-01	1	1	X		
		TW-1221-101	<a href="#">435490-01</a>				1	
11	Hose - Water Supply	EVA	425289-01	1	1	1		
12	Cover - Reservoir Inlet	SI.R	<a href="#">415094-01</a>	1	1	1		
13	Hose - Water Supply	EPDM	<a href="#">428615-05</a>	1	1	1		
14	Pipe - Drain	S.S	<a href="#">425292G01</a>	1	1	1		
15	Cap - Drain	Brass	425293-01	1	1	1		
16	Packing - Drain	Sy.R	<a href="#">425294-01</a>	1	1	1		
17	Clamp	MH-30N	421642-04	2	2	2		
18	Clamp	MH-44N	<a href="#">421642-07</a>	1	1	1		
19	Clamp	SK-183	<a href="#">426148-07</a>	1	1	1		
20	Clamp	MH-56N	<a href="#">421642-09</a>	3	3	3		
21	-	-	-	-				
22	-	-	-	-				
23	Clamp	SK-250	426148-08	1	1	1		

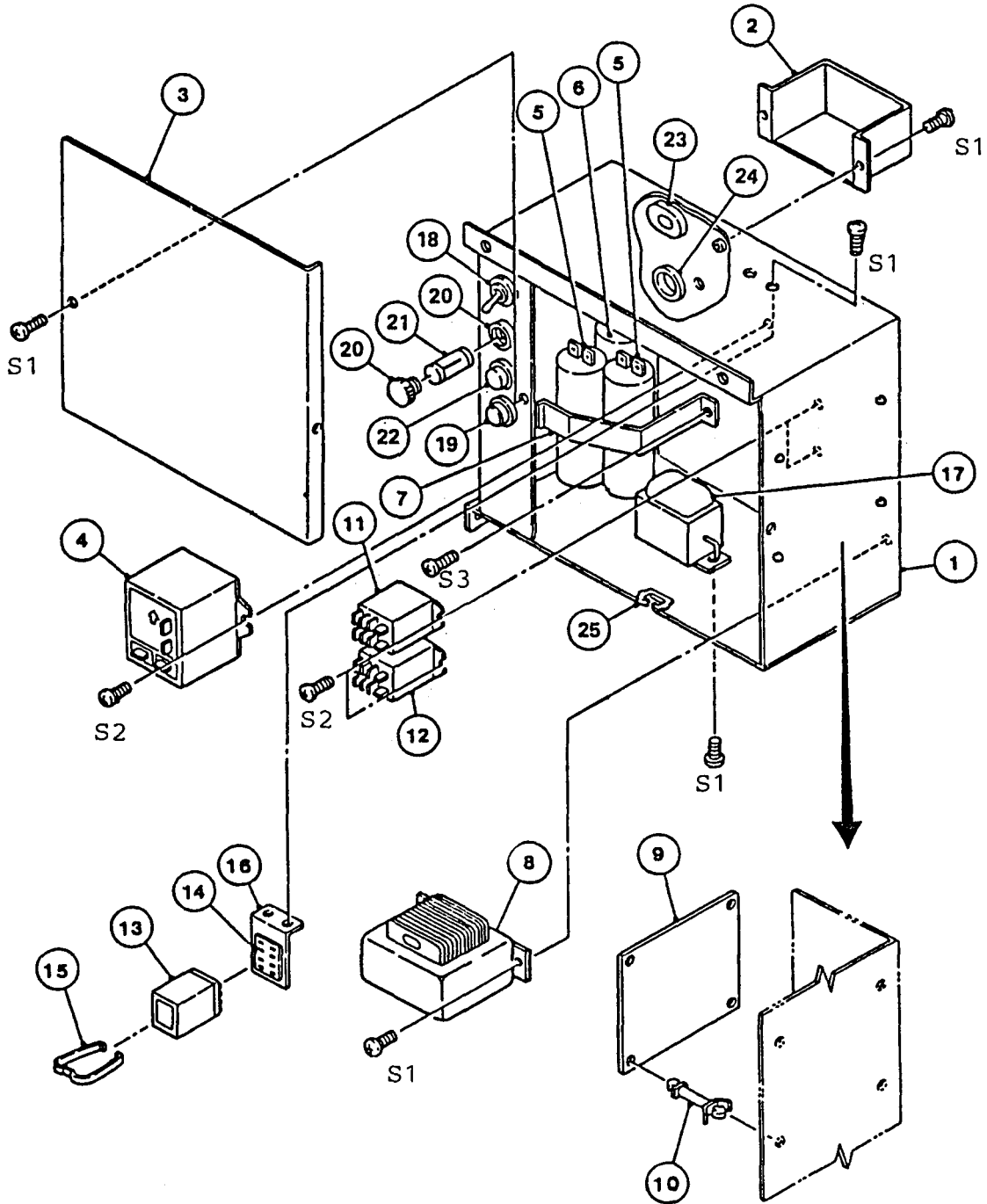

FASTENER

- S1 - TRUSS HEAD MACHINE SCREW, M4x6
- S2 - TRUSS HEAD TAPPING SCREW, M3x8
- S3 - TRUSS HEAD MACHINE SCREW, M4x8

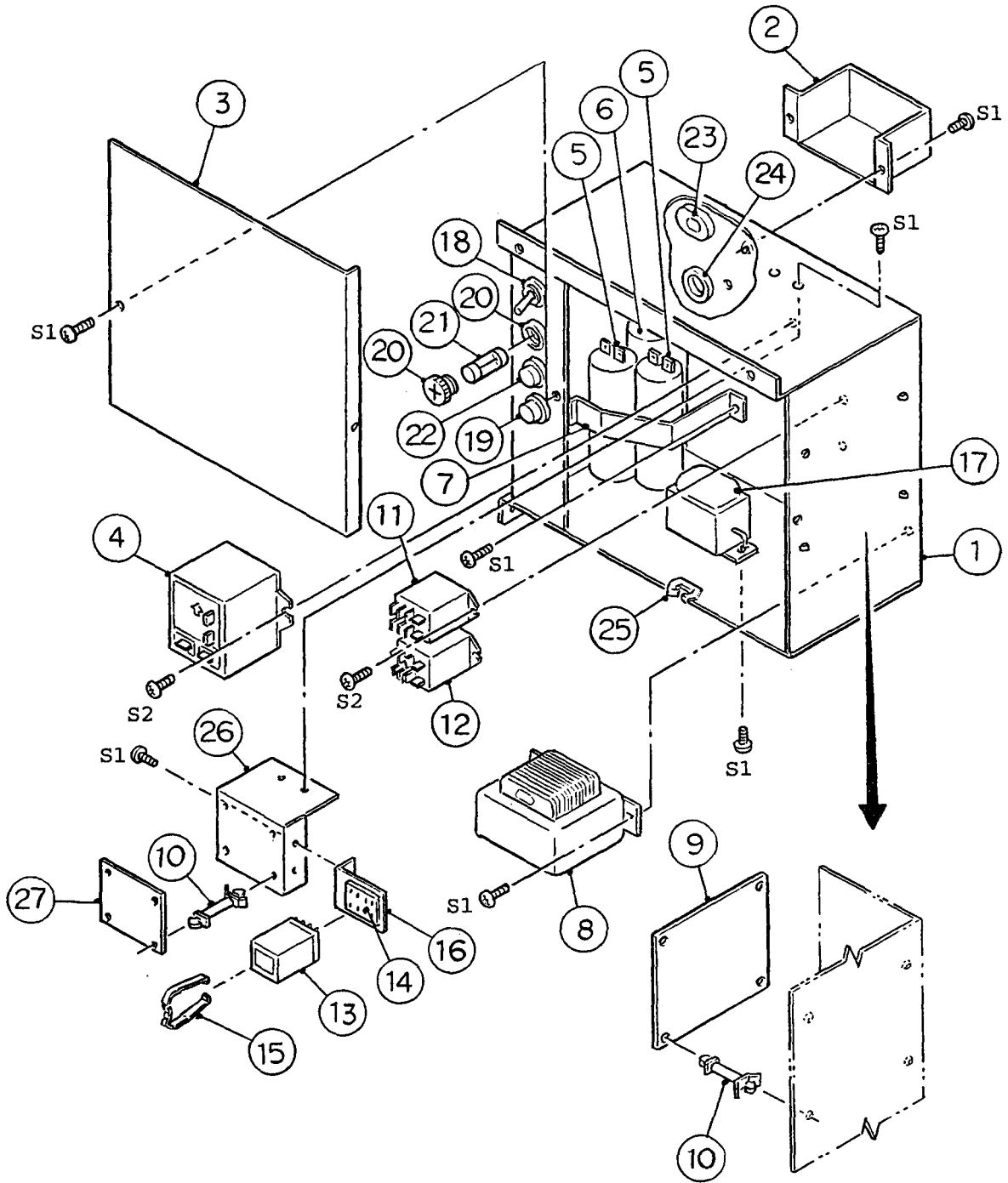

FASTENER

- S1 - TRUSS HEAD MACHINE SCREW, M4x8
- S2 - TRUSS HEAD TAPPING SCREW, M3x8

MODEL  
F-1101AU

TITLE  
E. CONTROL BOX ASSEMBLY

INDEX NO.	DESCRIPTION	MATERIAL OR MODEL NUMBER	PART NUMBER	REQ'D NUMBER				
				E-1	F-1	F-2	G-1	G-2
1	Control Box	G.S	315746G04	1	1	1	1	1
2	Cover - Connector	G.S	425302-01	1	1	1	1	1
3	Cover - Control Box	G.S	425301-01	1	1	1	1	1
4	Starter	FST-275B	422619-01	1	1	1	1	1
5	Start Capacitor	MS180F100(J)-R	3U0054-01	2	2	2	2	2
6	Run Capacitor	PMT-40250(P)	3U0058-01	1	1	-		
		PMT-SH	431200-01			1	1	1
7	Strap - Capacitor	G.S	425299-01	1	1	-		
			431394-01			1	1	1
8	Transformer	TR5268	2U0041-01	1	1	1	1	1
9	Timer Board	424292	424292-01	1	1	1	1	1
10	Board Support	KGLS-6S	414929-01	4	4	4	4	4
11	Relay	LY1F-US	422608-02	1	1	1	1	1
12	Relay	LY2ZFAG-US	427318-01	1	1	1	1	1
13	Keep Relay	MY2K-HO	418524-03	1	1	1	1	1
14	Socket - Relay	PY-14	408328-02	1	1	1	1	1
15	Clamp - Relay	PYC-P	411353-01	1	1	1	1	1
16	Bracket - Relay	G.S	425300-01	1	1	1	1	1
17	Thermostat	A22-2504	425202-01	1	1	1	1	1
18	Toggle Switch	S-421	3U0039-01	1	1	1	1	1
19	Push Button Switch	SB-4011N/OT3959	420466-01	1	1	1	1	1
20	Fuse Holder	FH032	424288-01	1	1	1	1	1
21	Fuse	FGAO-2, 1A	420468-03	1	1	1	1	1
22	Overload - Gear Motor	W58xBIA4A-2	425201-01	1	1	1	1	X
23	Bushing	SR-4K-4	420472-01	1	1	1	1	1
24	Bushing	SB-625-8	420470-01	1	1	1	1	1
25	Edge Saddle	EDS-1	421552-01	1	1	1	1	1

MODEL F-1101AU		TITLE E. CONTROL BOX ASSEMBLY						
INDEX NO.	DESCRIPTION	MATERIAL OR MODEL NUMBER	PART NUMBER	REQ'D NUMBER				
				H-0	J-1			
1	Control Box	G.S	315746G04	1	1			
2	Cover - Connector	G.S	425302-01	1	1			
3	Cover - Control Box	G.S	425301-01	1	1			
4	Starter	PST-275B	422619-01	1	1			
5	Start Capacitor	MS180F100(J)-R	<a href="#">3U0054-01</a>	2	2			
6	Run Capacitor	PMT-SH	431200-01	1	1			
7	Strap - Capacitor	G.S	431394-01	1	1			
8	Transformer	TR5268	2U0041-01	1	1			
9	Timer Board	424292	424292-01	1	1			
10	Board Support	KGLS-6S	414929-01	4	8			
11	Relay	LY1F	418271-04	1	1			
12	Relay	LY2ZF	406132-06	1	1			
13	Keep Relay	MY2K-HO	418524-03	1	1			
14	Socket - Relay	PY-14	<a href="#">408328-02</a>	1	1			
15	Clamp - Relay	PYC-P	411353-01	1	1			
16	Bracket - Relay	G.S	425300-01	1	1			
17	Thermostat	A22-2504	<a href="#">425202-01</a>	1	-			
		A10-9756	<a href="#">420465-01</a>		1			
18	Toggle Switch	S-421	3U0039-01	1	1			
19	Push Button Switch	SB-4011N/OT3959	<a href="#">420466-01</a>	1	1			
20	Fuse Holder	FH032	424288-01	1	1			
21	Fuse	FGA0-2 1A	<a href="#">420468-03</a>	1	1			
22	Overload - Gear Motor	W58xBIA4A-2	<a href="#">425201-01</a>	1	1			
23	Bushing	SR-4K-4	420472-01	1	1			
24	Bushing	SB-625-8	<a href="#">420470-01</a>	1	1			
25	Edge Saddle	EDS-1	421552-01	1	1			
26	Beeper Bracket	G.S	323312-01		1			
27	Beeper	-	435937-01		1			

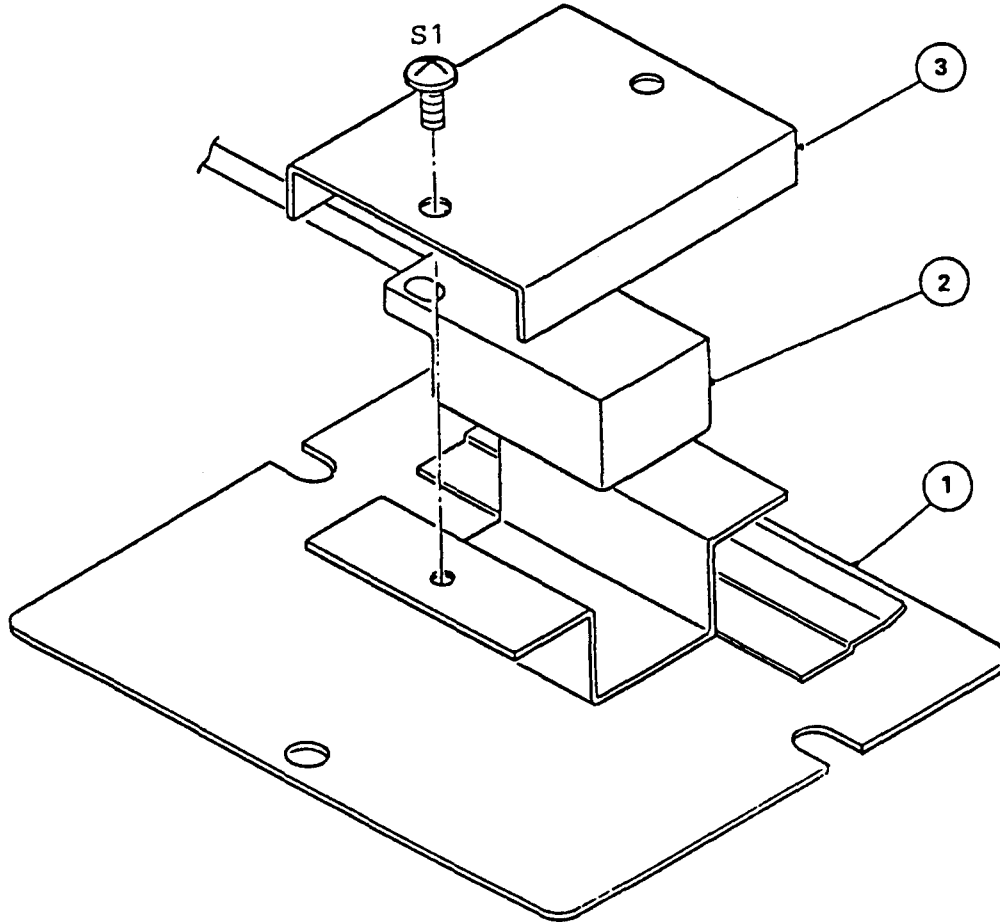

FASTENER

S1 - TRUSS HEAD MACHINE SCREW, STAINLESS, M4x6

MODEL		TITLE						
F-1101AU		F. BIN SWITCH ASSEMBLY						
INDEX NO.	DESCRIPTION	MATERIAL OR MODEL NUMBER	PART NUMBER	REQ'D NUMBER				
				E-1	F-1	F-2	G-1	G-2
1	Bracket - Switch	S.S	317648G01	1	1	1	1	1
2	Proximity Switch - Bin Control	RS-601	427223-01	1	1	1	1	1
3	Bracket - Proximity Switch	S.S	427158-01	1	1	1	1	1

MODEL F-1101AU		TITLE P. BIN SWITCH ASSEMBLY						
INDEX NO.	DESCRIPTION	MATERIAL OR MODEL NUMBER	PART NUMBER	REQ'D NUMBER				
				H-0	J-1			
1	Bracket - Switch	S.S	317648G01	1	1			
2	Proximity Switch - Bin Control	RS-601	427223-01	1	1			
3	Bracket - Proximity Switch	S.S	427158-01	1	1			



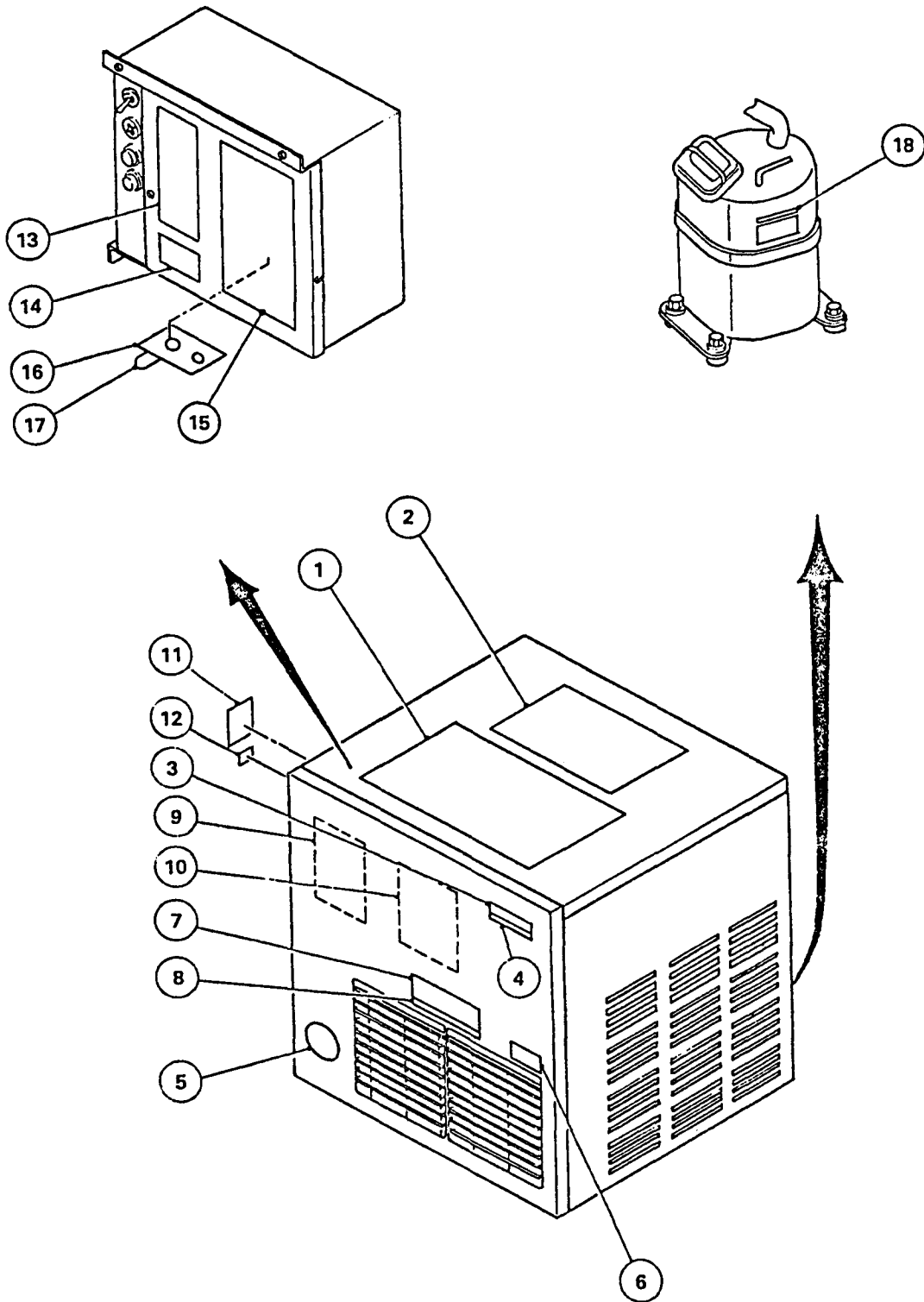

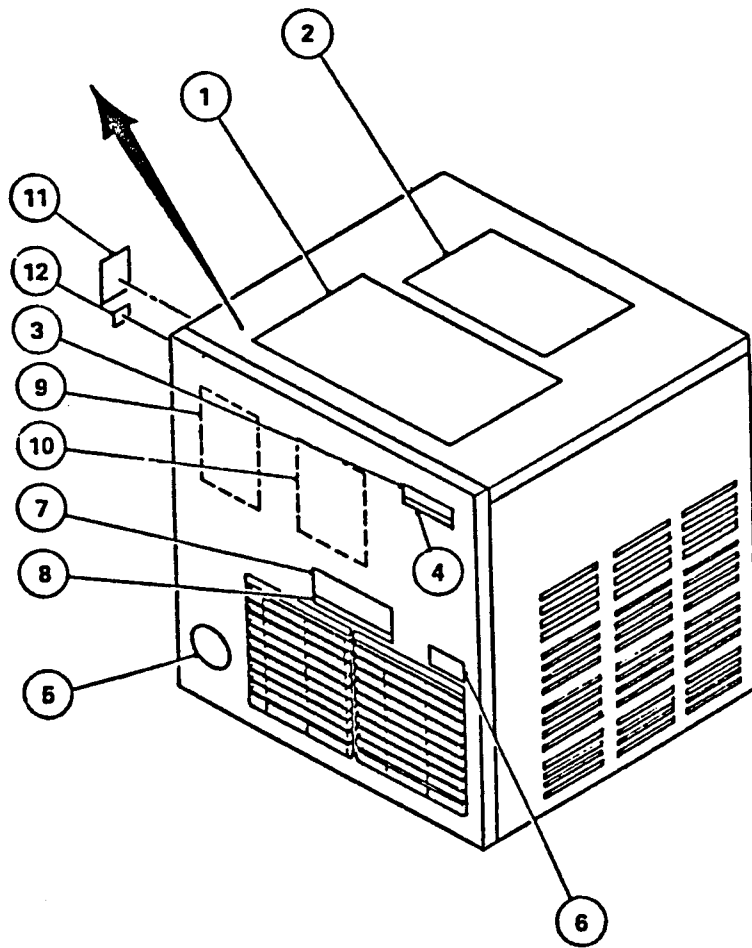
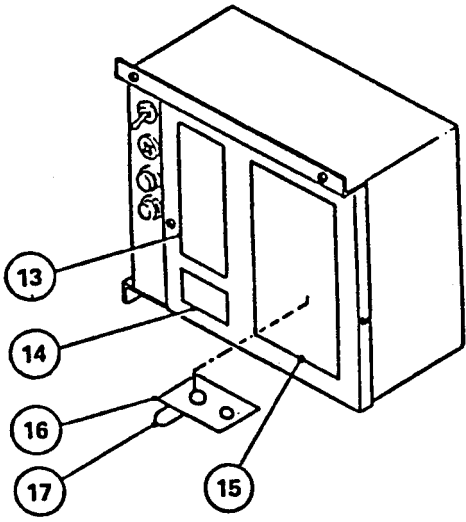

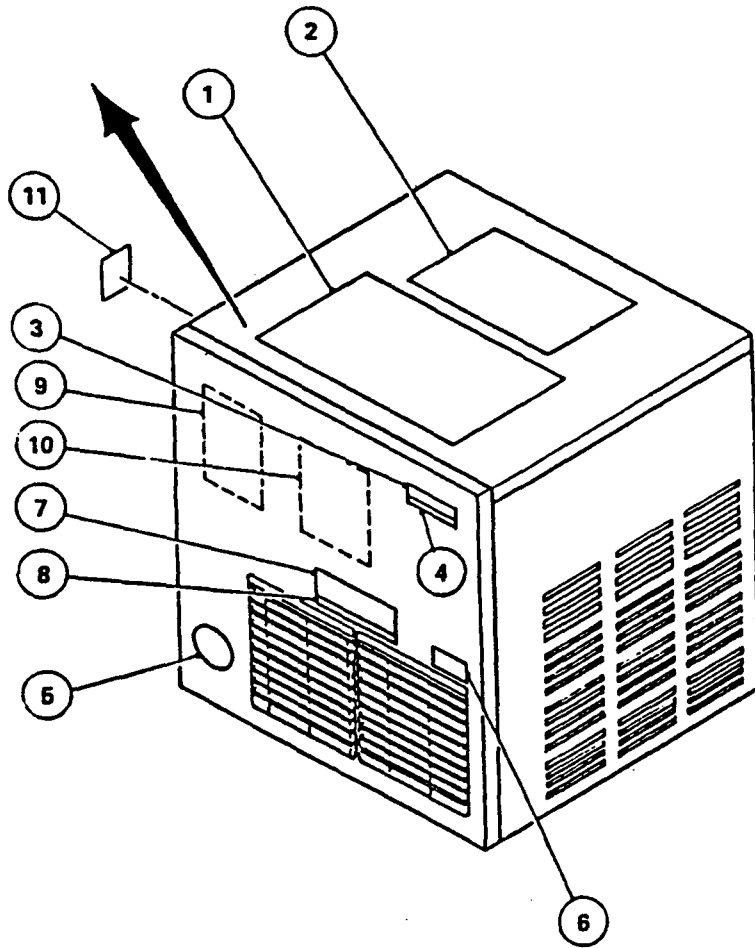
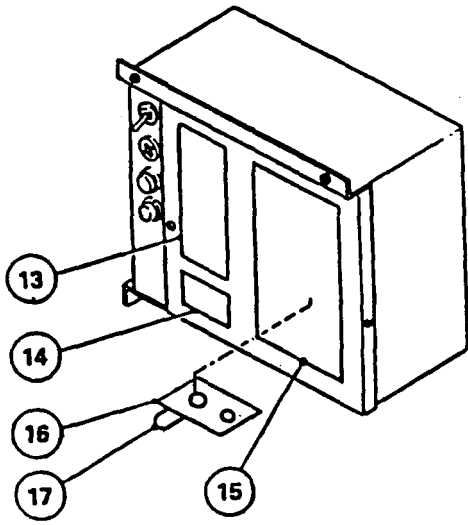

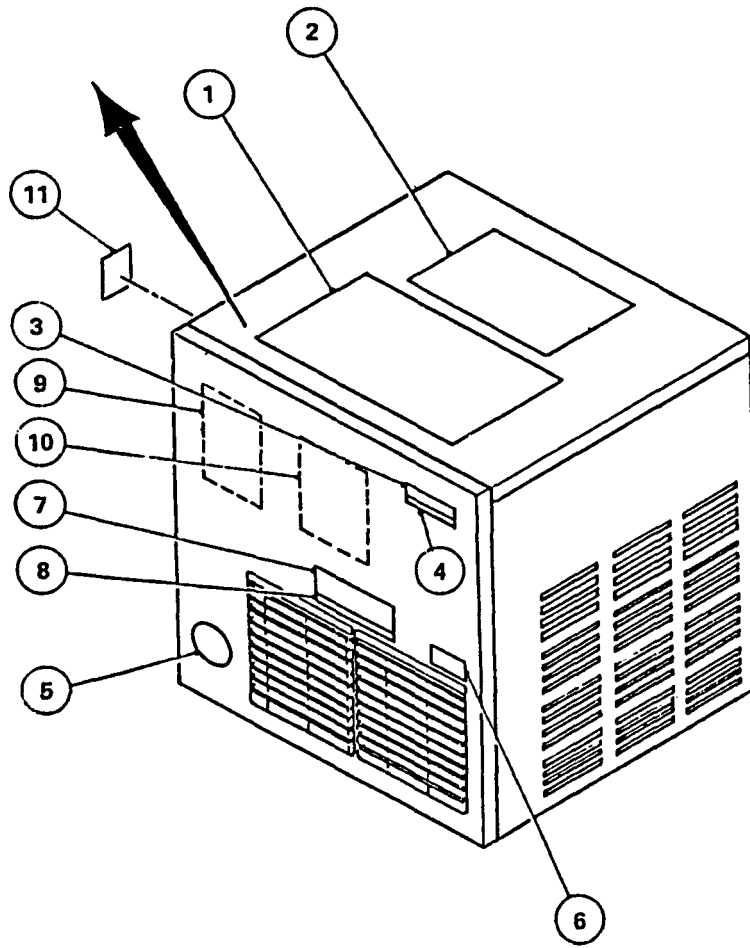
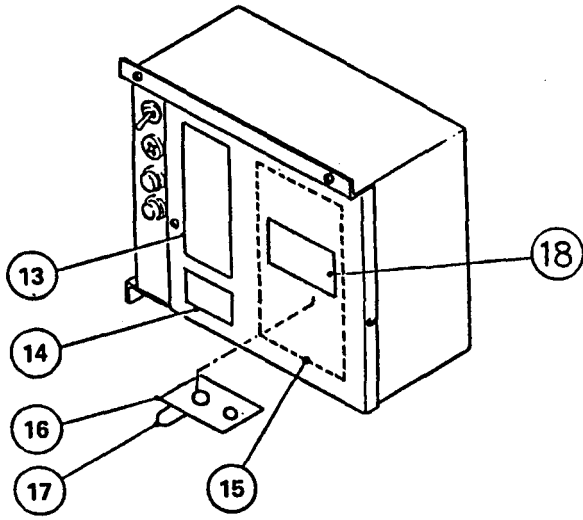

MODEL F-1101AU		TITLE G. LABEL LOCATION						
INDEX NO.	DESCRIPTION	MATERIAL OR MODEL NUMBER	PART NUMBER	REQ'D NUMBER				
				E-1	F-1	F-2	G-1	G-2
1	Instruction Sheet - Inst. Ope.	Paper	208144-01	1	1	1	1	1
2	Instruction Sheet - Bin Inst.	Paper	208145-01	1	1	1	1	1
3	Emblem (L) - HOSHIZAKI	ABS	418634G01	1	1	1	1	1
4	Label - Model Number	PETP Film	425305-**	1	1	1	1	1
5	Label - Penguin	PETP Film	410994-01	1	1	1	1	1
6	Label - Warning	PVC Film	425323-01	1	1	1	1	1
7	Label - Operation, Spout Cont.	PETP Film	425325-01	1	1	1	1	1
8	Label - Air Filter	PETP Film	426177-01	1	1	1	1	1
9	Label - Operation	PVC Film	315758-01	1	1	1	1	1
10	Label - Cleaning	PVC Film	208146-01	1	1	1	1	X
			211624-01					1
11	Nameplate	PES Film	428989-01	1	1	1	1	-
			432827-01					1
12	Label - NSF	-	423170-01	1	1	1	1	-
13	Label - Control Box	PETP Film	425329-01	1	1	1	1	1
14	Label - Danger	PVC Film	425322-01	1	1	1	1	1
15	Label - Wiring Diagram	PVC Film	317653-01	1	1	1	1	1
16	Label - Spout Control	PETP Film	428016-01	1	1	1	1	1
17	Label - Factory Adjusted	PETP Film	419404-01	1	1	1	1	1
18	Label - Thermally Protected	PES Film	427316-01	1	1	1	-	

\*\* is as same as the Auxiliary Code.

MODEL F-1101AU		TITLE G. LABEL LOCATION			REQD NUMBER				
INDEX NO.	DESCRIPTION	MATERIAL OR MODEL NUMBER	PART NUMBER	REQD NUMBER					
				H-0	J-1				
1	Instruction Sheet - Inst. Ope.	Paper	208144-01	1	1				
2	Instruction Sheet - Bin Inst.	Paper	208145-01	1	1				
3	Emblem (L) - HOSHIZAKI	ABS	418634G01	1	1				
4	Label - Model Number	PETP Film	425305-**	1	1				
5	Label - Penguin	PETP Film	410994-01	1	1				
6	Label - Warning	PVC Film	425323-01	1	1				
7	Label - Operation, Spout Cont.	PETP Film	425325-01	1	1				
8	Label - Air Filter	PETP Film	426177-01	1	1				
9	Label - Operation	PVC Film	315758-01	1	1				
10	Label - Cleaning	PVC Film	211624-01	1	1				
11	Nameplate	PES Film	432827-01	1	1				
12	-	-	-	-					
13	Label - Control Box	PETP Film	425329-01	1	1				
14	Label - Danger	PVC Film	425322-01	1	1				
15	Label - Wiring Diagram	PVC Film	317653-01	1	-				
	Wiring Label	PVC Film	323349-01		1				
16	Label - Spout Control	PETP Film	428016-01	1	-				
	Label - Bin Thermostat	PETP Film	435984-01		1				
17	Label - Factory Adjusted	PETP Film	419404-01	1	1				
18	-	-		-					
19	Warning Label	PVC Film	435955-01		1				

\*\* is as same as the Auxiliary Code.

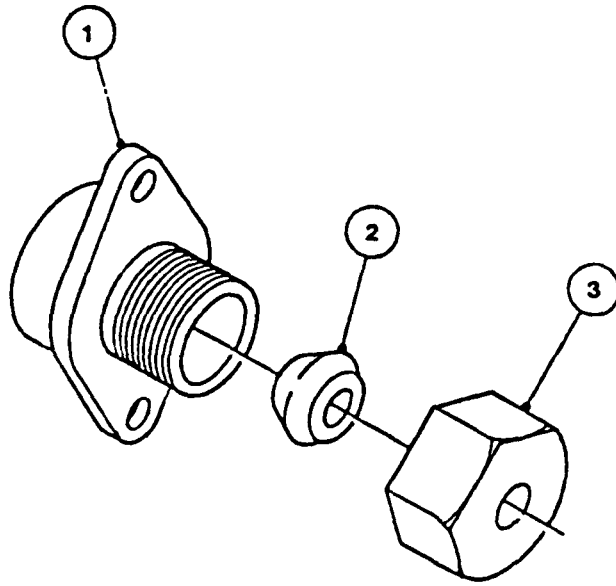

MODEL		TITLE						
F-1101AU		H. FITTING (K) ASSEMBLY						
INDEX NO.	DESCRIPTION	MATERIAL OR MODEL NUMBER	PART NUMBER	REQ'D NUMBER				
				E-1	F-1	F-2	G-1	G-2
1	Fitting (K)	Brass Casting	310978-01	1	1	1	1	1
2	Packing (C)	Sy.R	415715-02	1	1	1	1	1
3	Nut (B)	Brass	415713-02	1	1	1	1	1



MODEL		TITLE						
<b>F-1101AU</b>		<b>H. FITTING (K) ASSEMBLY</b>						
INDEX NO.	DESCRIPTION	MATERIAL OR MODEL NUMBER	PART NUMBER	REQ'D NUMBER				
				H-0	J-1			
1	Fitting (K)	Brass Casting	310978-01	1	1			
2	Packing (C)	Sy.R	415715-02	1	1			
3	Nut (B)	Brass	415713-02	1	1			

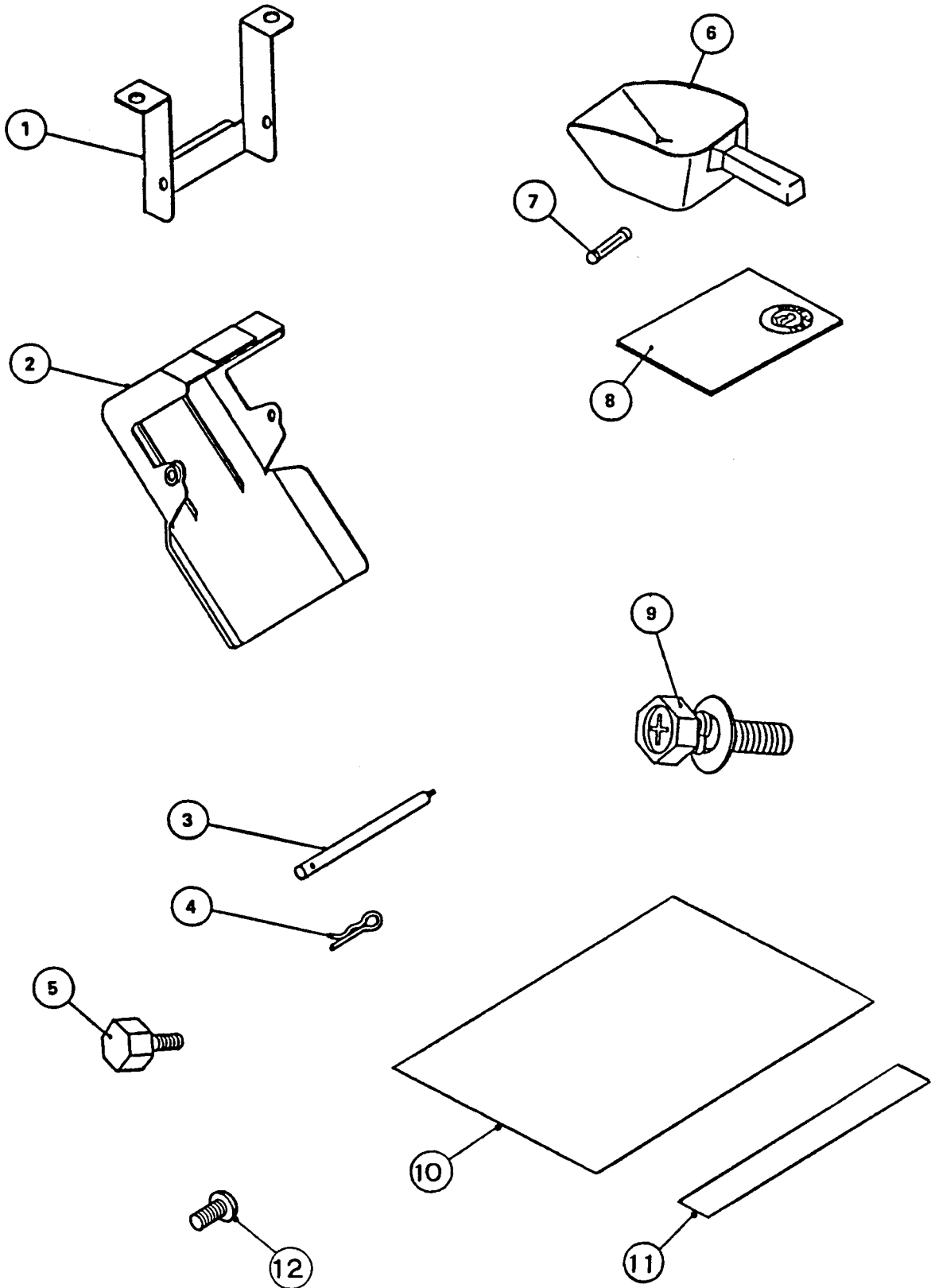

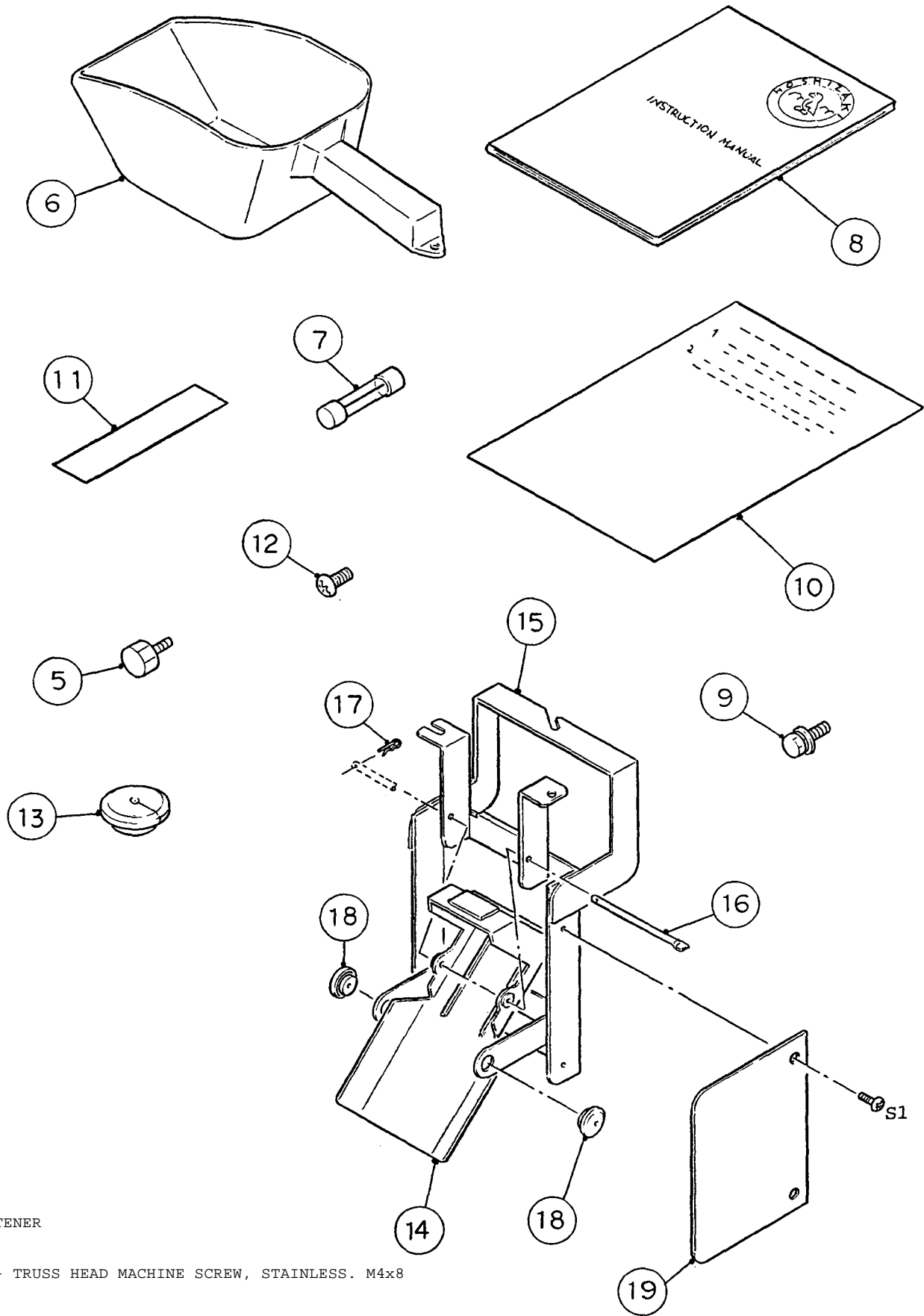

FASTENER

S1 - TRUSS HEAD MACHINE SCREW, STAINLESS. M4x8

MODEL F-1101AU		TITLE J. ACCESSORIES						
INDEX NO.	DESCRIPTION	MATERIAL OR MODEL NUMBER	PART NUMBER	REQ'D NUMBER				
				E-1	F-1	F-2	G-1	G-2
1	Bracket - Actuator	S.S	428003-01	1	1	1	1	1
2	Actuator - Switch	ABS	209168G01	1	1	1	1	1
3	Shaft	S.S	412337-03	1	1	1	1	1
4	Snap Pin	S.S, SSP-4	715S-0004	1	1	1	1	1
5	Thumbscrew	S.S, ABS	415949G04	3	3	3	3	3
6	Scoop	PE	208185-01	1	1	1	1	1
7	Fuse	FGA0-2, 1A	420468-03	1	1	1	1	1
8	Instruction Manual	Paper	9021G-14A	1	-			
			91U2AA10A		1	1	1	X
			91U2AA10B					1
9	Bolt And Washer Assy SW	S.S, M8x16	-	2	2	2	2	2
10	Instruction Sheet - Actuator	Paper	317651-01	1	1	1	1	1
11	Instruction Sheet - Fastener	Paper	427122-01	1	1	1	1	1
12	Truss Head Machine Screw	S.S, M4x30	-	2	2	2	2	2

MODEL F-1101AU		TITLE J. ACCESSORIES			REQ'D NUMBER				
INDEX NO.	DESCRIPTION	MATERIAL OR MODEL NUMBER	PART NUMBER	REQ'D NUMBER					
				H-0	J-1				
1	Bracket - Actuator	S.S	428003-01	1	-				
2	Actuator - Switch	ABS	209168G01	1	-				
3	Shaft	S.S	412337-03	1	-				
4	Snap Pin	S.S, SSP-4	715S-0004	1	-				
5	Thumbscrew	S.S, ABS	415949G04	3	3				
6	Scoop	PE	208185-01	1	1				
7	Fuse	FGA0-2, 1A	420468-03	1	1				
8	Instruction Manual	Paper	91U2AA10B	1	-				
			91U2AA10C		1				
9	Bolt And Washer Assy SW	S.S, M8x16	-	2	2				
10	Instruction Sheet - Actuator	Paper	317651-01	1	-				
	Instruction Sheet - Bin Control		323351-01		1				
11	Instruction Sheet - Fastener	Paper	427122-01	1	1				
12	Truss Head Machine Screw	S.S, M4x30	-	2	2				
13	Bushing - Cappillary Tube		425307-01		1				
14	Actuator - Switch		209168G01		1				
15	Bin Control Bracket	Bin Control	323306G01		1				
16	Shaft	Assembly	412337-03		1				
17	Snap Pin	(323318A01)	715S-0004		1				
18	Bushing - Cappillary Tube		425307-01		2				
19	Paddle Cover (B)		435869-01		1				

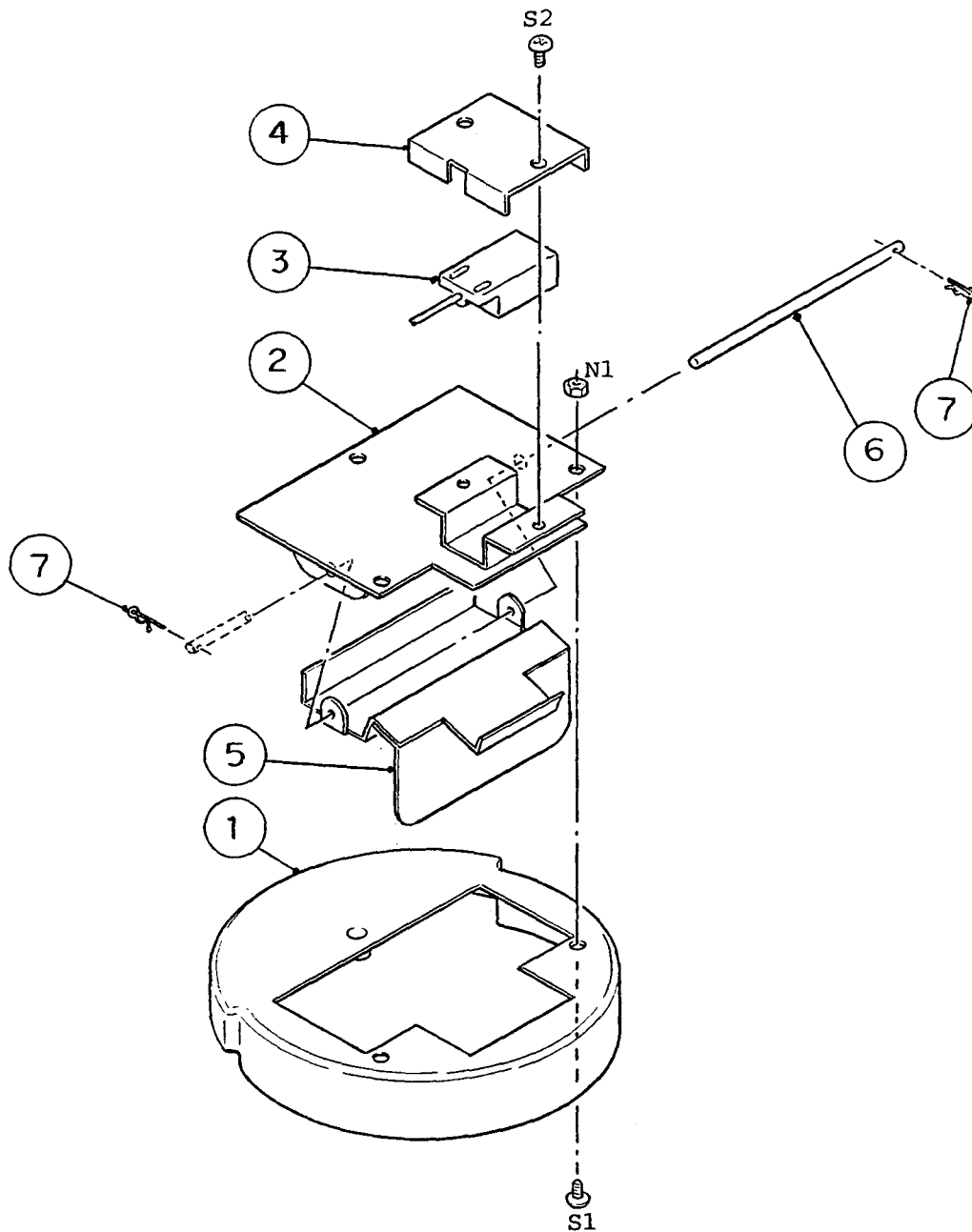

FASTENER

- S1 - TRUSS HEAD MACHINE SCREW, STAINLESS, M4x8
- S2 - TRUSS HEAD MACHINE SCREW, STAINLESS, M4x6
- N1 - U Nut, STAINLESS, M4

MODEL		TITLE						
F-1101AU		K. SPOUT CONTROL ASSEMBLY						
INDEX NO.	DESCRIPTION	MATERIAL OR MODEL NUMBER	PART NUMBER	REQ'D NUMBER				
					J-1			
1	Cover - Chute	ABS	213116G01		1			
2	Spout Cover	S.S	323307G01		1			
3	Proximity Switch	RS-601	427223-01		1			
4	Bracket - Proximity Switch	S.S	427158-01		1			
5	Paddle	S.S	323310G01		1			
6	Axle	S.S	435873-01		1			
7	Snap Pin	S.S, SSP-4	715S-0004		2			