

Hoshizaki America, Inc.

Modular Flaker

Models

F-1500MAH(-C)

F-1500MWH(-C)

F-1500MRH(-C)



“A Superior Degree
of Reliability”

www.hoshizaki.com

PARTS LIST



Number: 71223
Issued: 11-11-2004
Revised: 10-8-2014

CONTENTS

Auxiliary Codes.....	3
Note About Ordering Parts	4
A. Main Assembly & Refrigeration Circuit	5
F-1500MAH(-C)	5
F-1500MWH(-C)	8
F-1500MRH(-C).....	11
B. Icemaking Unit.....	14
C. Water Circuit.....	17
D. Control Box Assembly.....	19
D. Control Box Assembly.....	20
E. Accessories & Labels	22

Auxiliary Codes

F-1500MAH	N-0	October 2003	F-1500MAH-C	P-0	January 2004
	P-0	March 2004		P-1	April 2004
	P-1	April 2004		P-2	June 2004
	P-2	June 2004		Q-0	June 2005
	Q-0	January 2005		R-0	December 2005
	R-0	December 2005		S-0	January 2007
	S-0	January 2007		S-1	September 2007
	T-0	January 2008		T-0	January 2008
	T-1	August 2008		T-1	August 2008
	U-0	January 2009		U-0	January 2009
	U-1	April 2009		U-1	November 2009
	V-0	January 2010		V-0	March 2010
	V-1	September 2010		V-1	September 2010
	V-2	November 2010		V-2	November 2010
	A-0	January 2011		A-0	January 2011
	A-1	November 2011		A-1	November 2011
	B-0	January 2012		B-1	March 2012
	B-1	March 2012		C-0	February 2013
	C-0	January 2013		C-1	June 2013
	C-1	June 2013		C-2	August 2013
C-2	August 2013				
D-0	March 2014				
F-1500MWH			F-1500MWH-C	P-0	January 2004
	P-0	January 2004		P-1	May 2004
	P-1	May 2004		Q-0	March 2005
	Q-0	December 2004		Q-1	July 2005
	R-0	January 2006		R-0	August 2006
	S-0	March 2007		S-0	April 2007
	T-0	April 2008		S-1	July 2007
	T-1	August 2008		T-0	February 2008
	U-0	February 2009		U-0	February 2009
	U-1	September 2009		U-1	May 2009
	V-1	May 2010		V-0	January 2010
	V-3	November 2010		V-1	July 2010
	A-0	January 2011		V-2	September 2010
	A-1	December 2011		V-3	November 2010
	B-1	March 2012		A-0	January 2011
	C-0	February 2013		A-1	December 2011
	C-1	June 2013		B-0	February 2012
	C-2	August 2013		B-1	March 2012
	D-0	March 2014		C-0	January 2013
				C-1	March 2013
		C-2	August 2013		
		D-0	April 2014		

F-1500MRH	N-0	November 2003	F-1500MRH-C	P-0	January 2004
	P-0	December 2003		P-1	May 2004
	P-1	May 2004		Q-0	April 2005
	Q-0	January 2005		Q-1	July 2005
	R-0	December 2005		R-0	December 2005
	S-0	January 2007		S-0	January 2007
	T-0	March 2008		S-1	July 2007
	T-1	September 2008		T-0	January 2008
	U-0	February 2009		T-1	August 2008
	U-1	May 2009		U-0	March 2009
	V-0	January 2010		U-1	April 2009
	V-1	July 2010		V-1	June 2010
	V-2	October 2010		V-2	September 2010
	V-3	December 2010		V-3	November 2010
	A-0	January 2011		A-0	January 2011
	B-0	January 2012		A-1	October 2011
	B-1	March 2012		B-0	January 2012
	C-0	January 2013		B-1	March 2012
	C-1	June 2013		C-0	January 2013
	C-2	September 2013		C-1	June 2013
	D-0	January 2014		C-2	August 2013
				D-0	January 2014

Auxiliary Code Breakdown

The auxiliary code is the first two characters in the serial number. The first character indicates the year. Years progress or regress in alphabetical order. The series runs from "A" through "V" and the letters "I" and "O" are skipped. The second character indicates significant part changes within a year. Base is "0" and this number advances for each change. In cases where there is a letter in parentheses, this designates the month. This is the last character in the serial number. The series runs from "(A)" through "(M)" and the letter "(I)" is skipped. This designation is only included when identifying a parts change within an auxiliary code.

Note About Ordering Parts

Most assemblies cannot be ordered as complete units; parts in the assemblies generally must be ordered separately.

A. Main Assembly & Refrigeration Circuit

F-1500MAH(-C)

N-0 to D-0

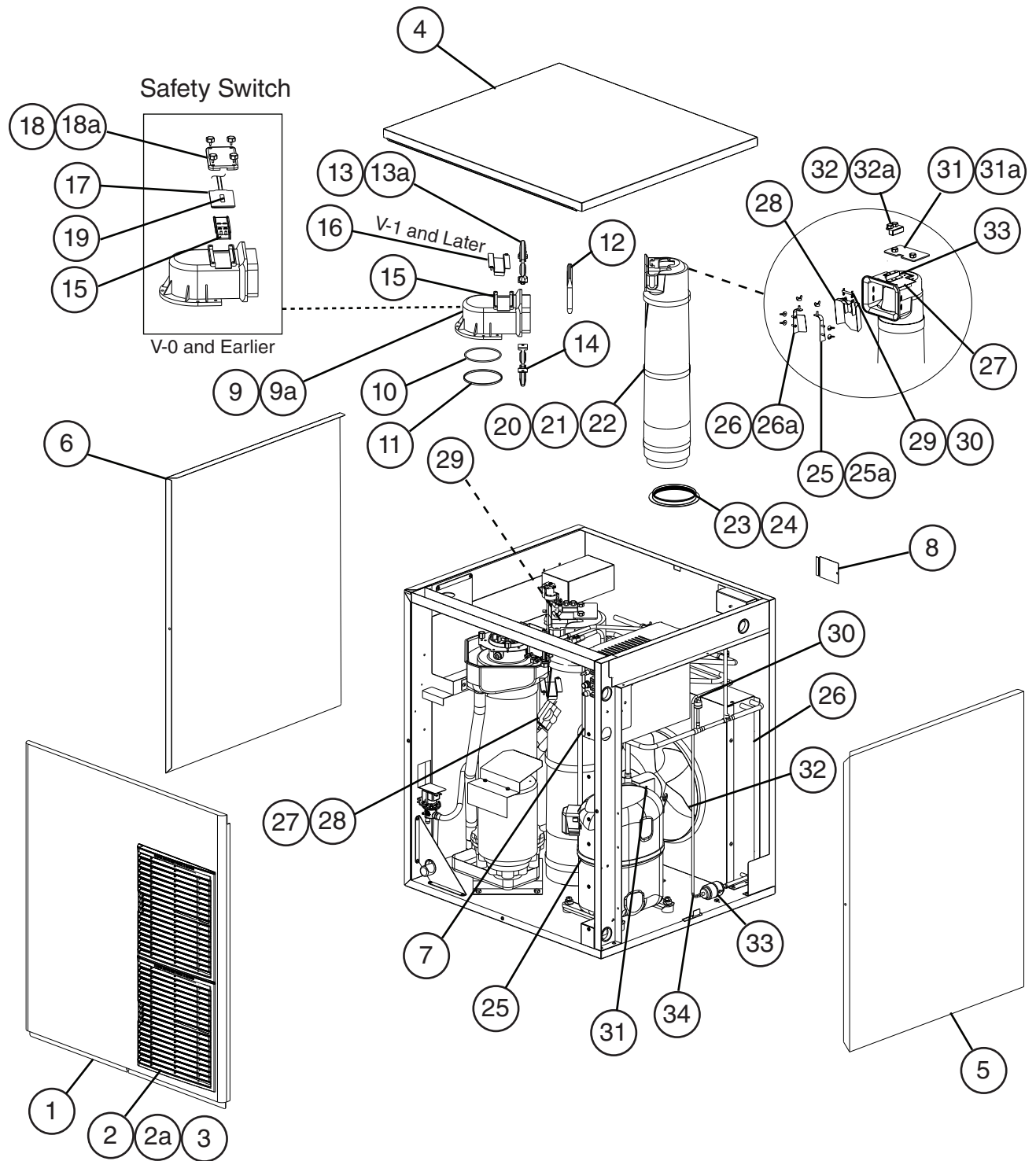

Title: A. Main Assembly & Refrigeration Circuit Model: F-1500MAH(-C)												
Index No.	Description	Material or Model Number	Part Number	Required Number								
				N-0 to V-0	V-1 to A-0	A-1 to D-0	B-1 to D-0					
Main Assembly												
1	Front Panel		2A2203-01	1	1	1	1					
2	Louver		1A0547-01	2	2	2	2					
2a	Push Retainer		4A2414-01	6	6	6	6					
3	Air Filter		2A2062G01	2	2	2	2					
4	Top Panel		2A2074-01	1	1	1	1					
5	Right Side Panel		2A2077G01	1	1	1	1					
6	Left Side Panel		2A2201G01	1	1	1	1					
7	Control Box Cover		3A2987-01	1	1	1	1					
8	Junction Box Cover		433410-01	1	1	1	1					
9	Spout		105378G01	1	1	1	1					
9a	Thumbscrew		415949G11	3	3	3	3					
10	O-Ring		4A4755-05	1	1	1	1					
11	Nylon Ring		431736-01	1	1	1	1					
12	Spout-to-Chute Packing		327040-01	1	1	1	1					
13	Upper Spout Strap		327042-04	1	1	1	-					
			3A6912-02				1					
13a	Wing Nut		7E12-0600	2	2	2	2					
14	Lower Spout Strap		327041G02	1	1	1	-					
			3A6913G01				1					
15	Safety Actuator		327038-01	1	-							
16	Spout Cover		4A5174-01		1	1	1					
17	Belt Switch (safety switch)		440973-01	1	-							
18	Switch Cover		327037-01	1	-							
18a	Thumb Screw		415949G04	1	-							
19	Direction Label		442816-01	1	-							
20	Chute		216219-01	1	1	1	1					
21	Chute Insulation		216220-01	1	1	1	1					
22	Chute Tie		436531G02	3	3	3	3					
23	Chute Packing		432877-02	1	1	1	1					
24	Ring		327427-01	1	1	1	1					
25	Chute Baffle A		341012G01		1	1	1					
25a	Wing Nut		7E12-0400		3	3	3					
26	Chute Baffle B		341013G01		1	1	1					
26a	Wing Nut		7E12-0400		3	3	3					
27	Mechanical Bin Control Bracket		3A1744G01		1	1	1					
28	Actuator		436848G02		1	1	1					
29	Shaft		436851-01		1	1	1					
30	Snap Pin		715S-0005		2	2	2					
31	Plate		4A2039-01		1	1	1					
31a	Thumbscrew		415949G10		2	2	2					
32	Mechanical Bin Control (proximity switch)		4A2033-01		1	1	1					
32a	Thumbscrew		415949G08		2	2	2					
33	Truss Head Screw (ground)		7C32-0408		1	1	1					

Title: A. Main Assembly & Refrigeration Circuit Model: F-1500MAH(-C)													
Index No.	Description	Material or Model Number	Part Number	Required Number									
				N-0 to V-0	V-1 to A-0	A-1 to D-0	B-1 to D-0						
Refrigeration Circuit													
25	Compressor		4A1539-01	1	1	-							
			4A1539-03			1	1						
26	Condenser		2A2215-01	1	1	1	1						
27	Thermostatic Expansion Valve		4A1117-01	1	1	1	1						
28	Thermostatic Expansion Valve Cover		4A1168-01	1	1	1	1						
29	Thermostatic Expansion Valve Bulb Holder		3A01112-01	1	1	1	1						
30	High-Pressure Switch		433441-05	1	1								
			463180-05			1	1						
31	Fan Motor		440911-01	1									
			4A3158-01		1	1	1						
32	Fan Blade		4A0197-01	1	1	1	1						
33	Drier		4A1113-01	1	1	1	1						
34	Heat Exchanger		3A2978G01	1	1	1	1						

Title: A. Main Assembly & Refrigeration Circuit Model: F-1500MWH(-C)

Index No.	Description	Material or Model Number	Part Number	Required Number							
				P-0 to V-0	V-1	V-2 to A-2	B-1 (C) to D-0				
Main Assembly											
1	Front Panel		2A2646-01	1	1	1	1				
2	Louver		1A0547-01	1	1	1	1				
2a	Push Retainer		4A2414-01	3	3	3	3				
3	Air Filter		2A2062G01	1	1	1	1				
4	Top Panel		2A2074-01	1	1	1	1				
5	Right Side Panel		2A2077G01	1	1	1	1				
6	Left Side Panel		2A2076G01	1	1	1	1				
7	Control Box Cover		3A2987-01	1	1	1	1				
8	Junction Box Cover		433410-01	1	1	1	1				
9	Spout		105378G01	1	1	1	1				
9a	Thumbscrew		415949G11	3	3	3	3				
10	O-Ring		4A4755-05	1	1	1	1				
11	Nylon Ring		431736-01	1	1	1	1				
12	Spout-to-Chute Packing		327040-01	1	1	1	1				
13	Upper Spout Strap		327042-04	1	1	1	-				
			3A6912-02				1				
13a	Wing Nut		7E12-0600	2	2	2	2				
14	Lower Spout Strap		327041G02	1	1	1	-				
			3A6913G01				1				
15	Safety Actuator		327038-01	1	1	-					
16	Spout Cover		4A5174-01			1	1				
17	Belt Switch (safety switch)		440973-01	1	1	-					
18	Switch Cover		327037-01	1	1	-					
18a	Thumbscrew		415949G04	1	1	-					
19	Direction Label		442816-01	1	1	-					
20	Chute		216219-01	1	1	1	1				
21	Chute Insulation		216220-01	1	1	1	1				
22	Chute Tie		436531G02	3	3	3	3				
23	Chute Packing		432877-02	1	1	1	1				
24	Ring		327427-01	1	1	1	1				
25	Fan Motor		440917-01	1	1	1	1				
26	Fan Blade		434959-01	1	1	1	1				
27	Chute Baffle A		341012G01			1	1				
27a	Wing Nut		7E12-0400			3	3				
28	Chute Baffle B		341013G01			1	1				
28a	Wing Nut		7E12-0400			3	3				
29	Mechanical Bin Control Bracket		3A1744G01			1	1				
30	Actuator		436848G02			1	1				
31	Shaft		436851-01			1	1				
32	Snap Pin		715S-0005			2	2				
33	Plate		4A2039-01			1	1				
33a	Thumbscrew		415949G10			2	2				
34	Mechanical Bin Control (proximity switch)		4A2033-01		1	1	1				
34a	Thumbscrew		415949G08		2	2	2				
35	Truss Head Screw (ground)		7C32-0408		1	1	1				

Title: A. Main Assembly & Refrigeration Circuit Model: F-1500MWH(-C)											
Index No.	Description	Material or Model Number	Part Number	Required Number							
				P-0 to V-0	V-1	V-2 to A-2	B-1 (C) to D-0				
Refrigeration Circuit											
27	Compressor		4A1539-01	1	1	1	-				
			4A1539-03				1				
28	Condenser		2A2359G04	1	1	1	-				
			3A7236-01				1				
29	Thermostatic Expansion Valve		4A1117-01	1	1	1	1				
30	Thermostatic Expasion Valve Cover		4A1168-01	1	1	1	1				
31	Thermostatic Expasion Valve Bulb Holder		3A01112-01	1	1	1	1				
32	Water Regulating Valve		4A0911-04	1	1	1	1				
33	Male Connector		4A1087-01	1	1	1	1				
34	High-Pressure Switch		433441-05	1	-						
			463180-05		1	1	1				
35	Drier		4A1113-01	1	1	1	1				
36	Heat Exchanger		3A3025G01	1	1	1	1				

A. Main Assembly & Refrigeration Circuit

F-1500MRH(-C)

N-0 to D-0

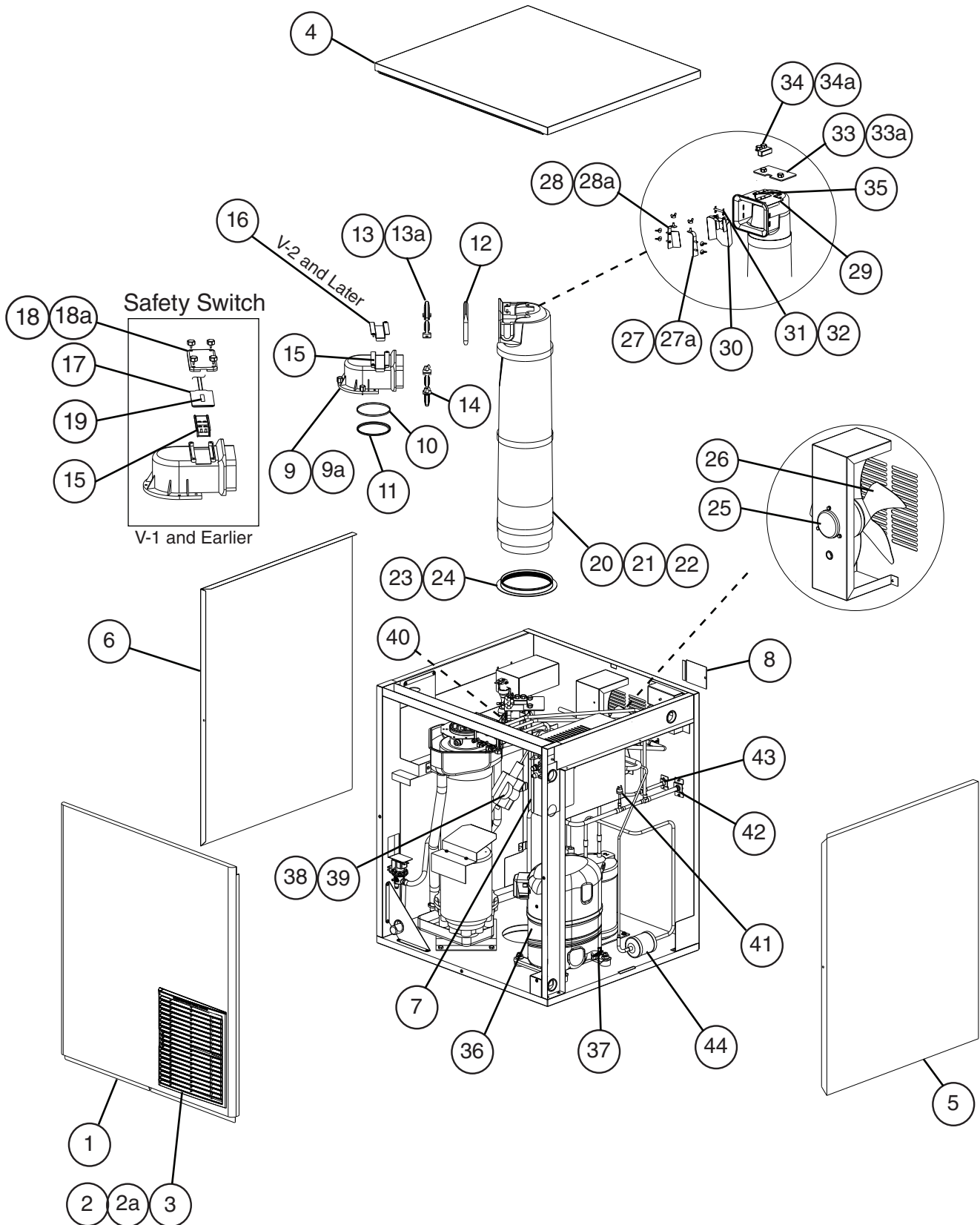

Title: A. Main Assembly & Refrigeration Circuit Model: F-1500MRH(-C)

Index No.	Description	Material or Model Number	Part Number	Required Number							
				N-0 to V-0	V-1	V-2 V-3	A-0 to D-0				
Main Assembly											
1	Front Panel		2A2646-01	1	1	1	1				
2	Louver		1A0547-01	1	1	1	1				
2a	Push Retainer		4A2414-01	3	3	3	3				
3	Air Filter		2A2062G01	1	1	1	1				
4	Top Panel		2A2074-01	1	1	1	1				
5	Right Side Panel		2A2077G01	1	1	1	1				
6	Left Side Panel		2A2076G01	1	1	1	1				
7	Control Box Cover		3A2987-01	1	1	1	1				
8	Junction Box Cover		433410-01	2	2	2	2				
9	Spout		105378G01	1	1	1	1				
9a	Thumbscrew		415949G11	3	3	3	3				
10	O-Ring		4A4755-05	1	1	1	1				
11	Nylon Ring		431736-01	1	1	1	1				
12	Spout-to-Chute Packing		327040-01	1	1	1	1				
13	Upper Spout Strap		327042-04	1	1	1	-				
			3A6912-02				1				
13a	Wing Nut		7E12-0600	2	2	2	2				
14	Lower Spout Strap		327041G02	1	1	1	-				
			3A6913G01				1				
15	Safety Actuator		327038-01	1	1	-					
16	Spout Cover		4A5174-01		1	1	1				
17	Belt Switch (safety switch)		440973-01	1	1	-					
18	Switch Cover		327037-01	1	1	-					
18a	Thumbscrew		415949G04	1	1	-					
19	Direction Label		442816-01	1	1	-					
20	Chute		216219-01	1	1	1	1				
21	Chute Insulation		216220-01	1	1	1	1				
22	Chute Tie		436531G02	3	3	3	3				
23	Chute Packing		432877-02	1	1	1	1				
24	Ring		327427-01	1	1	1	1				
25	Fan Motor		440917-01	1	1	1	1				
26	Fan Blade		434959-01	1	1	1	1				
27	Chute Baffle A		341012G01		1	1	1				
27a	Wing Nut		7E12-0400		3	3	3				
28	Chute Baffle B		341013G01		1	1	1				
28a	Wing Nut		7E12-0400		3	3	3				
29	Mechanical Bin Control Bracket		3A1744G01		1	1	1				
30	Actuator		436848G02		1	1	1				
31	Shaft		436851-01		1	1	1				
32	Snap Pin		715S-0005		2	2	2				
33	Plate		4A2039-01		1	1	1				
33a	Thumbscrew		415949G10		2	2	2				
34	Mechanical Bin Control (proximity switch)		4A2033-01		1	1	1				
34a	Thumbscrew		415949G08		2	2	2				
35	Truss Head Screw (ground)		7C32-0408		1	1	1				

Title: A. Main Assembly & Refrigeration Circuit Model: F-1500MRH(-C)													
Index No.	Description	Material or Model Number	Part Number	Required Number									
				N-0 to V-0	V-1	V-2 V-3	A-0 to D-0						
Refrigeration Circuit													
27	Compressor		4A1539-02	1	1	1	-						
			4A1539-03				1						
28	Crankcase Heater		4A5397-02				1						
29	Thermostatic Expasion Valve		4A1117-01	1	1	1	1						
30	Thermostatic Expansion Valve Cover		4A1168-01	1	1	1	1						
31	Thermostatic Expasion Valve Bulb Holder		3A0112-01	1	1	1	1						
32	High-Pressure Switch		433441-05	1	-								
			463180-05		1	1	1						
33	Discharge Line Coupling		434072-01	1	1	1	1						
34	Liquid Line Coupling		426554-01	1	1	1	1						
35	Drier		4A1338-01	1	1	1	1						

B. Icemaking Unit

F-1500MAH(-C), F-1500MWH(-C), F-1500MRH(-C)

N-0 to D-0

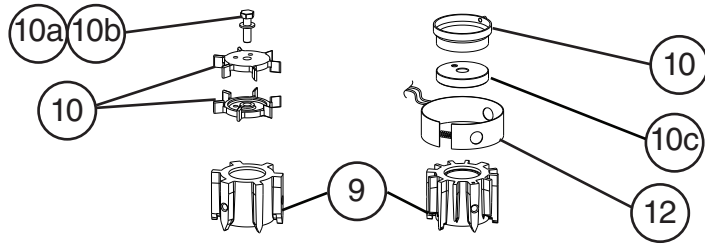

Flaker

Cubelet (-C)

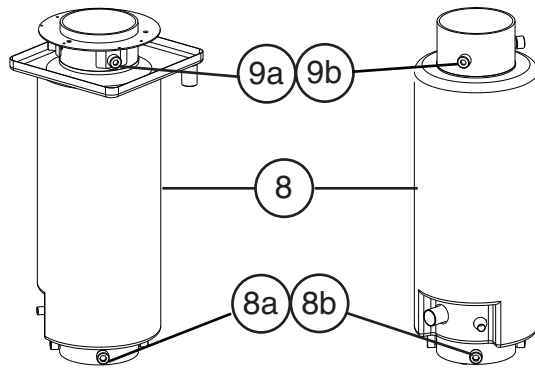
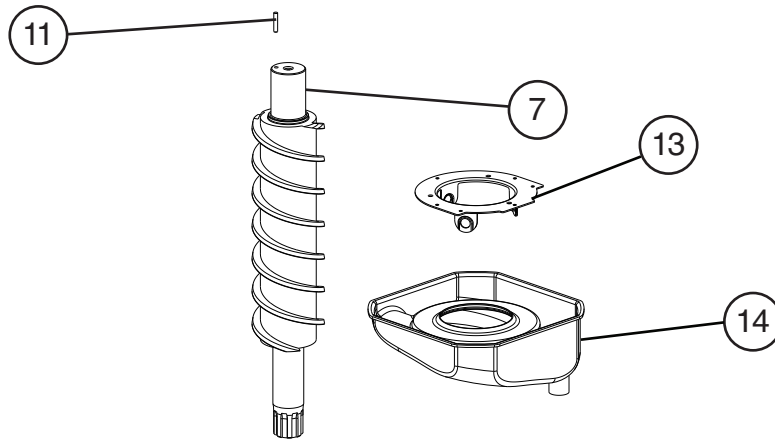

N-0 to U-1 (L)

U-1 (M) and later

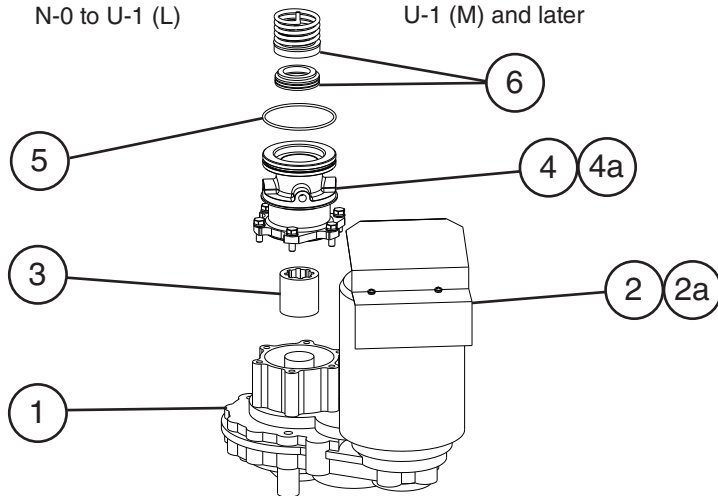

Title: B. Icemaking Unit Model: F-1500MAH(-C), F-1500MWH(-C), F-1500MRH(-C)													
Index No.	Description	Material or Model Number	Part Number	Required Number									
				N-0 to P-2	Q-0 (A-F)	Q-0 (G) to U-1 (L)	U-1 (M) to V-1	V-2 to A-0	A-1 to C-1	C-2 to D-0			
1	Gear Motor		2U0129-01	1	1	1	1	1	1	1	1		
2	Gear Motor Barrier		3A1639-01	1	1	1	1	1	1	1	1		
2a	Truss Head Screw	4x8, SS	7C32-0408	2	2	2	2	2	2	2	2		
3	Spline Coupling		420372-01	1	1	1	1	1	1	1	1		
4	Housing		206509G02	1	1	1	1	1	1	1	1		
4a	Hex Bolt	8x25, SS	7B02-0825	6	6	6	6	6	6	6	6		
5	O-Ring		4A4755-04	1	1	1	1	1	1	1	1		
6	Mechanical Seal		432493-01	1	1	1	1	1	1	1	1		
7	Auger		233811G02	1	-								
			114121G02		1	1	1	-					
			120864G02					1	1	1			
8	Evaporator		2A2200G01	1	1	-							
			2A3316G01			1	-						
			2A3316G02				1	1	1	-			
			2A7005G01								1		
8a	Socket Head Cap Screw	10x20, SS	7S12-1020	4	4	4	4	4	4	4	4		
8b	Split Lock Washer		7L22-1000	4	4	4	4	4	4	4	4		
9	Extruding Head	F-1500MAH F-1500MWH F-1500MRH	216407G01	1	1	1	1	1	1	1	1		
		F-1500MAH-C F-1500MWH-C F-1500MRH-C	2A2202G01	1	1	-							
			2A1594G01			1	1	1	1	1	1		
9a	Seal Bolt		474757G01	3	3	3	3	3	-				
			474757G02							3	3		
9b	Washer		425277-01	3	3	3	3	3	-				
			474757G02							3	3		
10	Cutter	F-1500MAH F-1500MWH F-1500MRH	327026-01	2	2	2	2	2	2	2	2		
		F-1500MAH-C F-1500MWH-C F-1500MRH-C	4A3070G02	1	1	-							
			315736G01			1	1	1	1	1	1		
10a	Hex Head Bolt	F-1500MAH F-1500MWH F-1500MRH 10x35, SS	7B02-1035	1	1	1	1	1	1	1			
		F-1500MAH-C F-1500MWH-C F-1500MRH-C 10x40, SS	7B02-1040	1	1	-							
10b	Split Lock Washer	F-1500MAH F-1500MWH F-1500MRH	7L22-1000	1	1	1	1	1	1	1	1		
		F-1500MAH-C F-1500MWH-C F-1500MRH-C		1	1	-							
10c	Washer	F-1500MAH-C F-1500MWH-C F-1500MRH-C	4A3071-01	1	1	-							

Title: B. Icemaking Unit Model: F-1500MAH(-C), F-1500MWH(-C), F-1500MRH(-C)												
Index No.	Description	Material or Model Number	Part Number	Required Number								
				N-0 to P-2	Q-0 (A-F)	Q-0 (G) to U-1 (L)	U-1 (M) to V-1	V-2 to A-0	A-1 to C-1	C-2 to D-0		
11	Dowel Pin	F-1500MAH F-1500MWH F-1500MRH	713S-0526	1	1	1	1	1	1	1		
		F-1500MAH-C F-1500MWH-C F-1500MRH-C		1	1	-						
12	Heater	F-1500MAH-C F-1500MWH-C F-1500MRH-C	4A4335-01			1	1	1	1	1		
13	Flange	F-1500MAH-C F-1500MWH-C F-1500MRH-C	352714-01				1	1	1	1		
14	Dip Pan		2A6885-01								1	

C. Water Circuit

F-1500MAH(-C), F-1500MWH(-C), F-1500MRH(-C)

N-0 to D-0

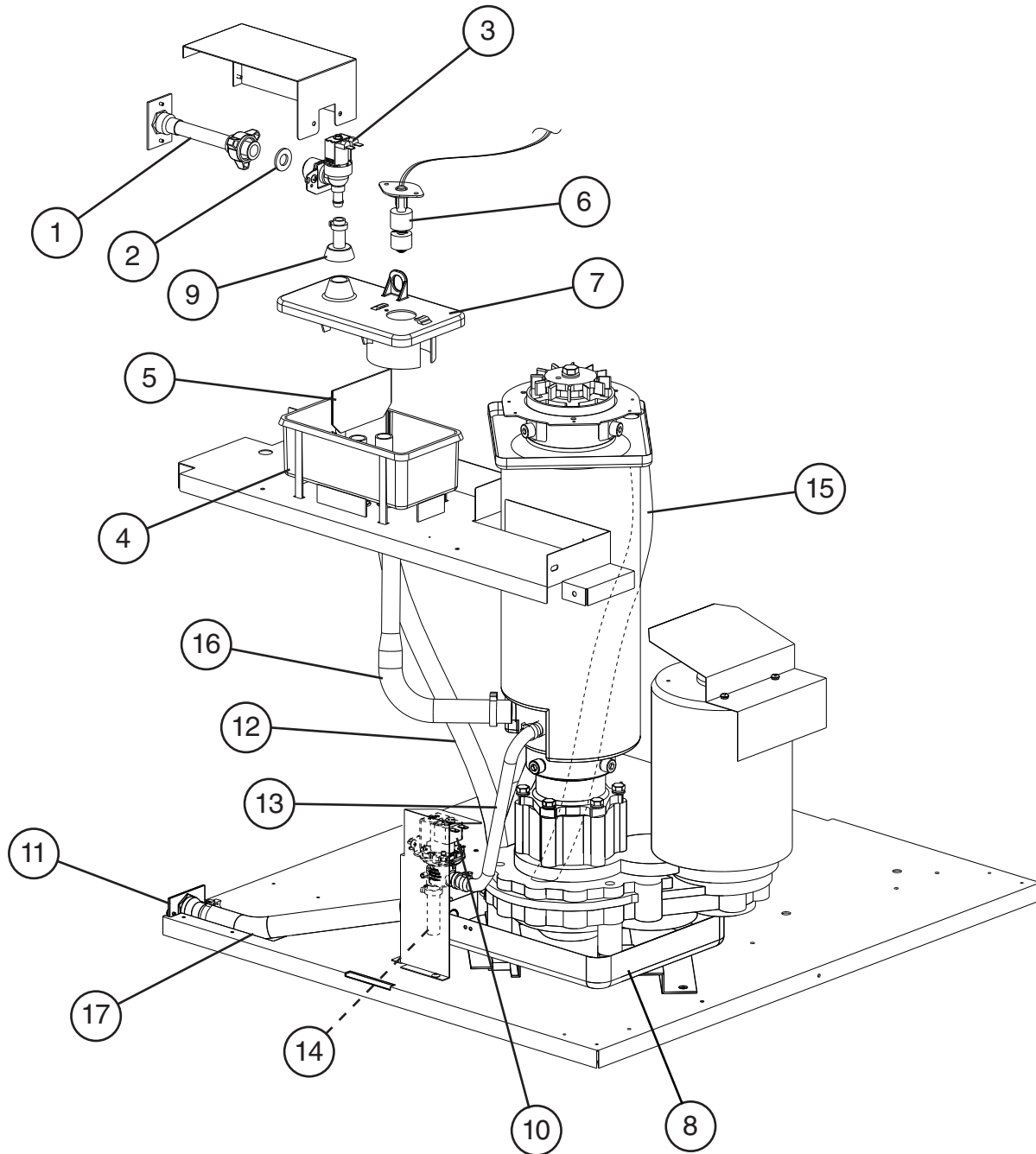

Title: C. Water Circuit Model: F-1500MAH(-C), F-1500MWH(-C), F-1500MRH(-C)												
Index No.	Description	Material or Model Number	Part Number	Required Number								
				N-0 to B-0	B-1 to C-1	C-2 D-0						
1	Water Supply Pipe		4A0891G01	1	-							
			4A0891G02		1	1						
2	Washer		4A0867-01	1	-							
			413854-03		1	1						
3	Inlet Water Valve		4A0865-01	1	-							
			4A5309-01		1	1						
4	Reservoir		2A0753-01	1	1	1						
5	Reservoir Separator		4A1255-01	1	1	1						
6	Float Switch		435490-01	1	1	1						
7	Reservoir Cover		214810-01	1	1	1						
8	Drain Pan		219358G01									
9	Inlet Reservoir		4A0869-01	1	1	1						
10	Drain Valve		4A2772-01	1	1	1						
11	Drain Fitting		4A0776G01	1	1	-						
			4A5528-01			1						
12	Silicone Hose	L=530 mm	7730-1822	1	1	-						
		L=510 mm	7725-1923			1						
13	Silicone Hose	L=320 mm	7730I3896	1	1	-						
14	Vinyl Hose	L=60 mm	7716-1216	1	1	1						
15	Vinyl Hose	L=640 mm	7725-1923	1	1	-						
			4A0658L01			1						
16	Water Supply Hose		428615-04	1	1	1						
17	Drain Pan Hose	L=330-335 mm	7716-2025	1	1	-						
		L=335 mm	3A7490-01			1						
Hose Clamps												
	Hose Clamp	13-15 mm	4A2017-08	3	3	3						
	Hose Clamp	15-17 mm	4A2017-07	1	1	1						
	Hose Clamp	19-22 mm	4A2017-06	1	1	1						
	Hose Clamp	26-30 mm	4A2017-02	2	2	2						
	Hose Clamp	21-26 mm	4A2017-01	3	3	3						

D. Control Box Assembly
F-1500MAH(-C), F-1500MWH(-C), F-1500MRH(-C)
N-0 to C-0

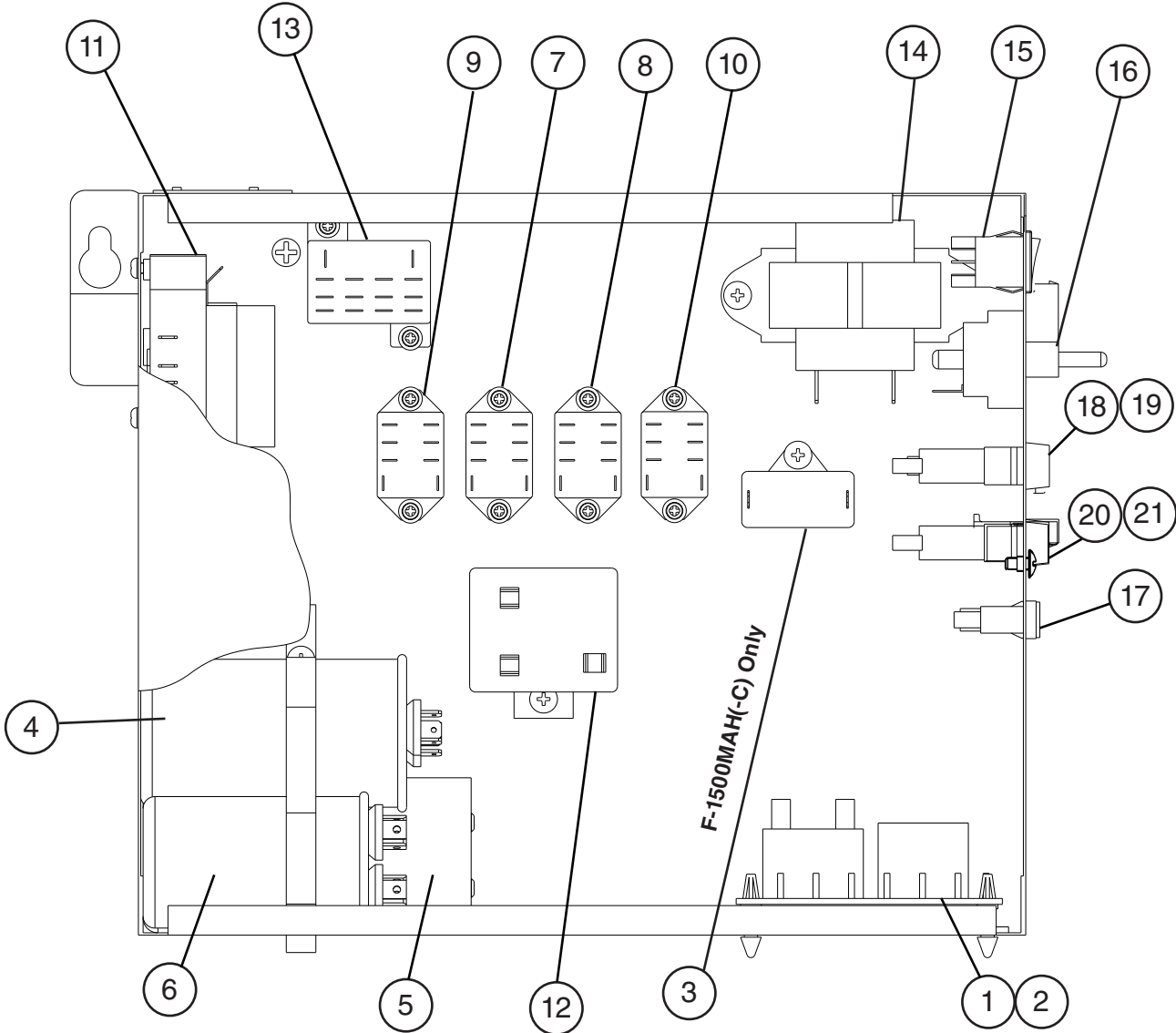

D. Control Box Assembly

F-1500MAH(-C), F-1500MWH(-C), F-1500MRH(-C)

C-1 to D-0

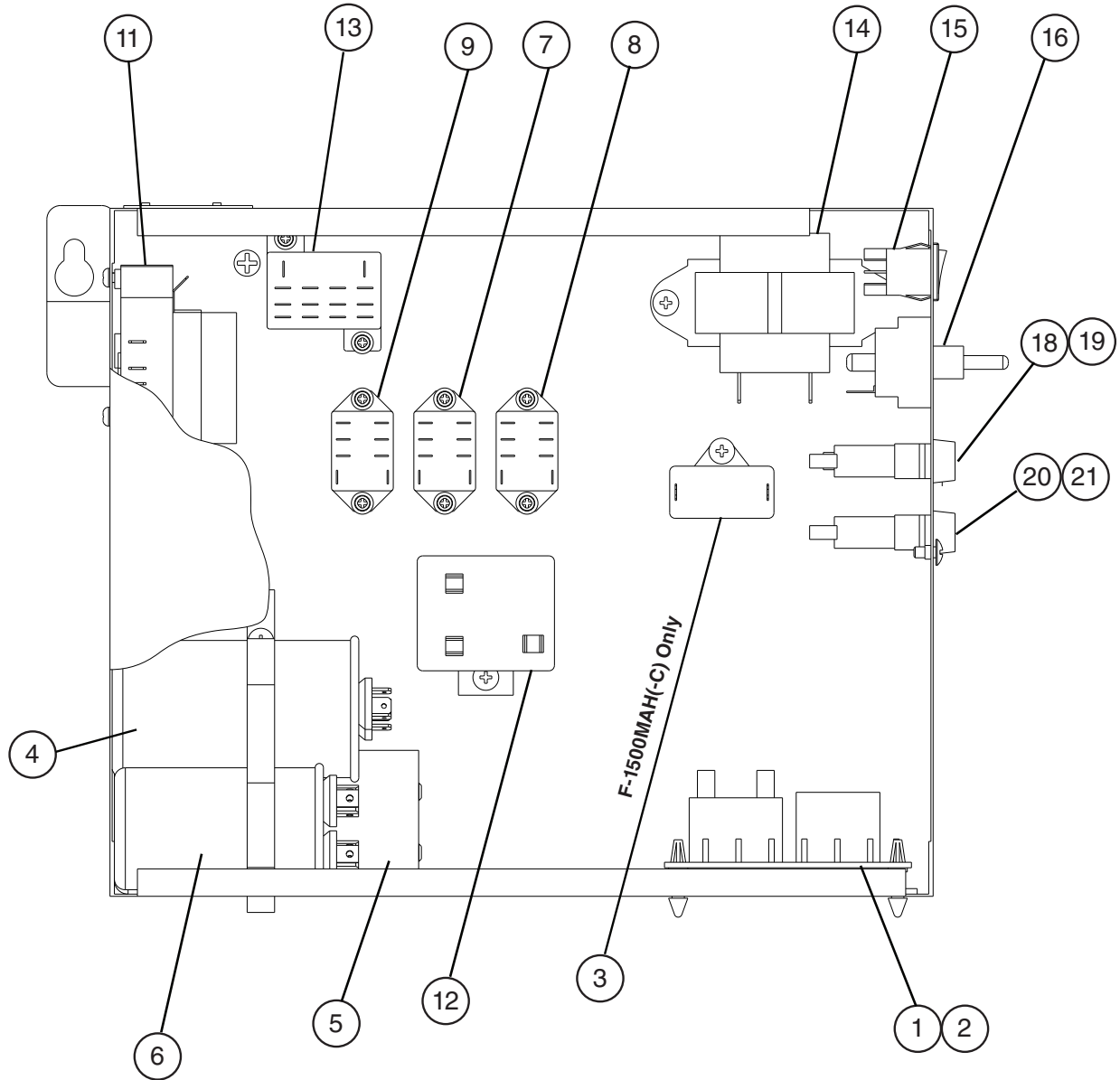

Title: D. Control Box Assembly Model: F-1500MAH(-C), F-1500MWH(-C), F-1500MRH(-C)											
Index No.	Description	Material or Model Number	Part Number	Required Number							
				N-0 to V-0	V-1	V-2 to A-2	B-1 to C-0	C-1 to D-0			
1	"L-A" Control Board		437305-01	1	1	1	1	-			
			4A5591-01					1			
2	Control Board Support		4A0336-03	4	4	4	4	4			
3	Fan Motor Capacitor	F-1500MAH(-C) 5MFD, 250VAC	443192-02	1	1	1	1	1			
4	Gear Motor Capacitor	65MFD, 250VAC	4A5450-01	1	1	1	1	1			
5	Start Capacitor	145-174MFD, 220VAC	3A0076-11	1	1	1	1	1			
6	Run Capacitor	30MFD, 370VAC	3A2005-03	1	1	1	1	1			
7	Water Control Relay		406132-03	1	1	1	1	1			
8	Gear Motor Protect Relay		418271-03	1	1	1	1	1			
9	Circuit Protect Relay		418271-05	1	1	1	1	1			
10	Spout Control Relay	F-1500MAH(-C)	406132-06	1	-						
		F-1500MWH(-C)		1	1	-					
		F-1500MRH(-C)									
11	Cam Timer		4A2157-01	1	1	1	1	1			
12	Start Relay		4A1107-13	1	1	1	1	1			
13	Gear Motor Relay		406133-04	1	1	1	1	1			
14	Control Transformer		4A0557-01	1	1	1	1	1			
15	Control Switch		4A0558-01	1	1	1	1	1			
16	Power Switch		4A2332-01	1	1	1	1	1			
17	Lamp	F-1500MAH(-C)	4A2672-01	1	-						
		F-1500MWH(-C)		1	1	1	-				
		F-1500MRH(-C)									
18	Fuse Holder (control board)		4A3449-01	1	1	1	1	1			
19	Fuse (control board)	AGC-1A, 250VAC	4A0893-01	1	1	1	1	1			
20	Fuse Holder (gear motor)		4A3449-02	1	1	1	1	1			
21	Fuse (gear motor)	GMD-7A, 250VAC Slow Blow	4A3804-01	1	1	1	1	1			

E. Accessories & Labels

F-1500MAH(-C), F-1500MWH(-C), F-1500MRH(-C)

N-0 to D-0

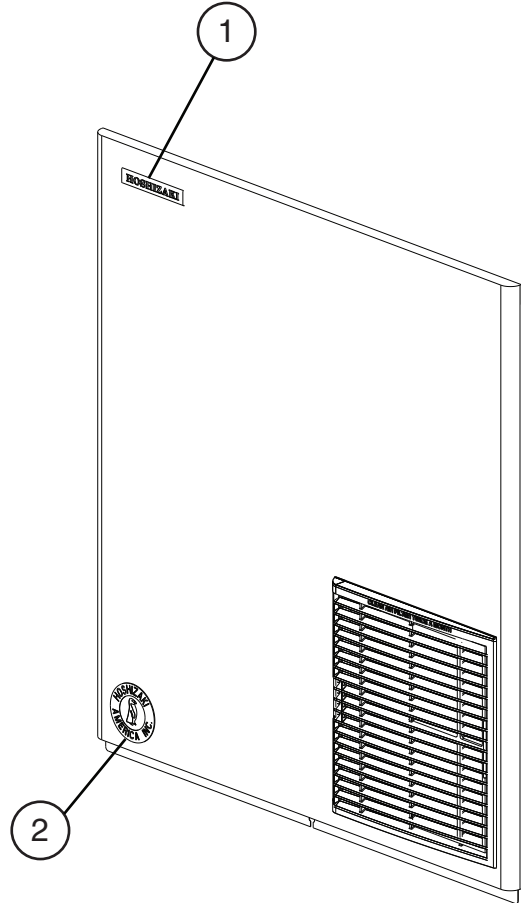

Title: E. Accessories & Labels Model: F-1500MAH(-C), F-1500MWH(-C), F-1500MRH(-C)													
Index No.	Description	Material or Model Number	Part Number	Required Number									
				N-0 to D-0									
1	Hoshizaki Emblem Label		4A0560-01	1									
2	Penguin Label		4A0526-01	1									
3	Universal Brace		4A0363-01	2									
4	Hex Head Bolts	5x12, SS	7B02-0512	2									