



HOSHIZAKI

Parts List

Self-Contained Flaker

Models

F-300BAF



hoshizakiamerica.com

Number: 71126
Issued: 10-20-2016

CONTENTS

Auxiliary Codes.....	3
Note About Ordering Parts	3
A. Main Assembly	4
B. Icemaking Unit	7
C. Water Circuit.....	9
D. Control Box Assembly.....	11
E. Accessories & Labels	13

Auxiliary Codes

F-300BAF

H-0	August 1998	B-0	January 2012
J-0	January 1999	B-1	March 2012
J-1	June 1999	C-0	January 213
K-0	December 1999	C-1	March 2013
K-1	April 2000	C-2	September 2013
K-2	May 2000	D-0	January 2014
L-0	December 2000	E-0	January 2015
L-1	May 2001	F-0	January 2016
M-0	December 2002		
M-1	October 2002		
N-0	December 2002		
P-0	December 2003		
P-1	November 2004		
Q-0	December 2004		
Q-1	October 2005		
R-0	December 2005		
S-0	January 2007		
S-1	June 2007		
T-0	January 2008		
U-0	January 2009		
U-1	February 2009		
V-0	January 2010		
V-1	May 2010		
V-2	June 1010		
A-0	February 2011		
A-1	April 2011		

Auxiliary Code Breakdown

The auxiliary code is the first two characters in the serial number. The first character indicates the year. Years progress or regress in alphabetical order. The series runs from "A" through "V" and the letters "I" and "O" are skipped. The second character indicates significant part changes within a year. Base is "0" and this number advances for each change. In cases where there is a letter in parentheses, this designates the month. This is the last character in the serial number. The series runs from "(A)" through "(M)" and the letter "(I)" is skipped. This designation is only included when identifying a parts change within an auxiliary code.

Note About Ordering Parts

Most assemblies cannot be ordered as complete units; parts in the assemblies generally must be ordered separately.

A. Main Assembly
F-300BAF
 H-0 to F-0

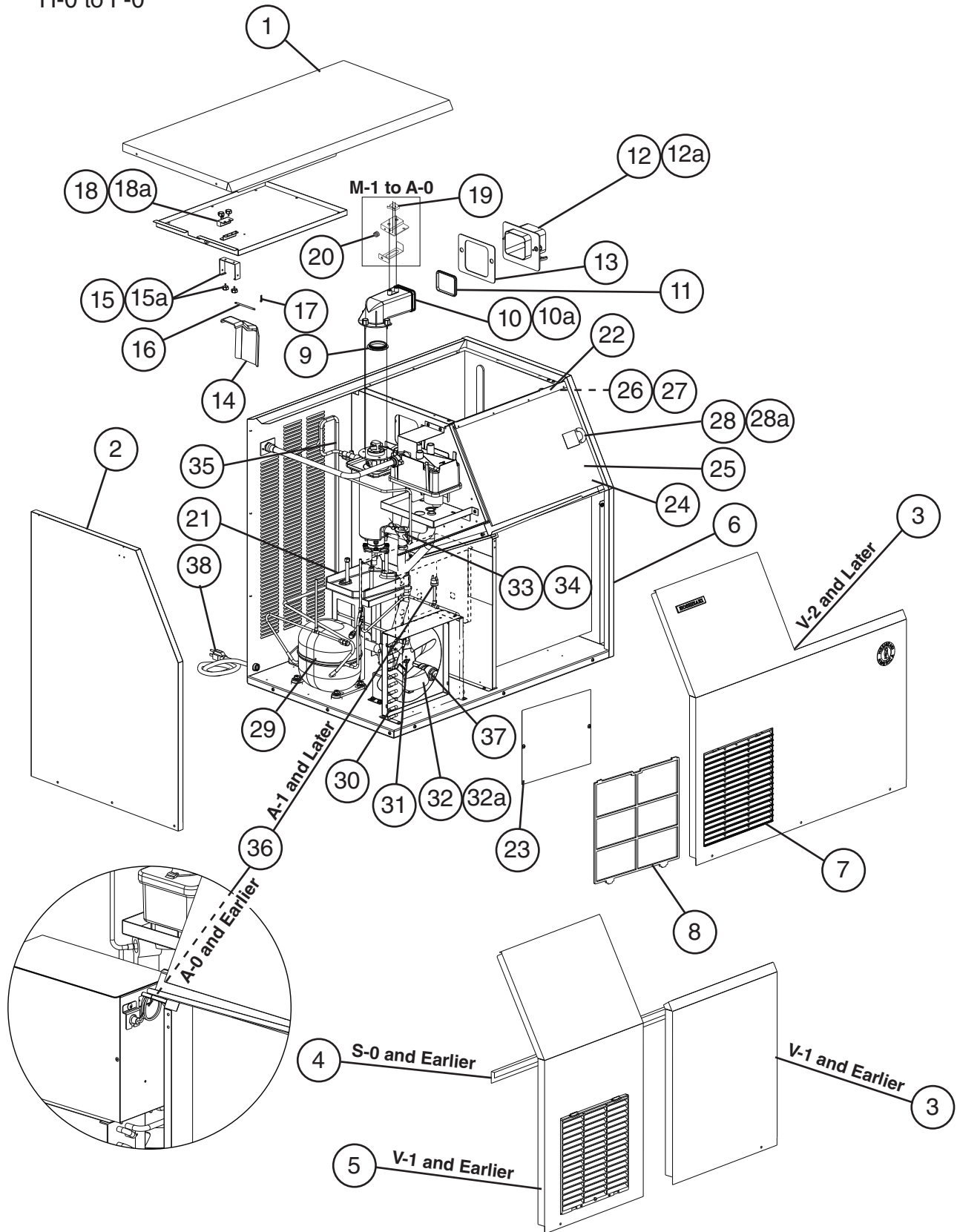

Title: A. Main Assembly Model: F-300BAF

Index No.	Description	Material or Model Number	Part Number	Required Number								
				H-0	J-0 to K-1	K-2 to M-0	M-1 to S-0	S-1 to T-0	T-1 to V-1	V-2 to A-0	A-1 to F-0	
Main Assembly												
1	Top Panel		341383G01	1	1	1	1	-				
			3A4053G01					1	1	1	1	
2	Left Side Panel		341385A01	1	1	-						
			341385A01			1	1	-				
			2A3874-01					1	1	1	1	
3	Right Front Panel		341371G01	1	1	-						
			3A1441A01			1	1	1	1	-		
	Front Panel								1	1		
4	Front Panel Bracket		341372-011	1	1	1	1	-				
5	Left Front Panel		341384G01	1	1	-						
			3a1442G01			1	1	1	1	-		
6	Right Side Panel		341386A02	1	1	1	1	-				
			2A3867-01					1	1	1	1	
7	Louver		103121-03	1	1	1	1	1	1	1	1	
8	Air Filter		208283G03	1	1	1	1	1	1	1	1	
9	Packing		427151-01	1	1	1	1	1	1	1	1	
10	Spout		227129-01	1	1	1	-					
			232636G01				1	1	1	1	1	
10a	Thumbscrew		415949G11	3	3	3	3	3	3	3	3	
11	Spout Packing A		453663-01	1	1	1	1	1	1	1	1	
12	Spout B		227130-01	1	1	1	-					
			232654-01				1	-				
			232654-03					1	1	1	1	
12a	Thumbscrew		415949G11	4	4	4	2	2	2	2	2	
13	Spout Packing B		4A2769-01	1	1	1	1	1	1	1	1	
14	Actuator		208795G01	1	1	1	1	1	1	1	1	
15	Actuator Hinge		317058-01	1	-							
			3A0762-01		1	1	1	1	1	1	1	
15a	Thumbscrew		415949G08	2	2	2	2	2	2	2	2	
16	Shaft		412337-03	1	1	1	1	1	1	1	1	
17	Snap Pin		715S-0004	1	1	1	1	1	1	1	1	
18	Proximity Switch (Bin Control)		4A2033-01	1	1	1	1	1	1	1	1	
18a	Thumbscrew		415949G08	2	2	2	2	2	2	2	2	
19	Microswitch (Safety Switch)		4A2832-01				1	1	1	1	-	
20	Spring		459287-01				1	1	1	1	-	
21	Drain Pan		323765G01	1	1	1	1	1	1	1	1	
22	Edging		425931-04	1	1	1	1	1	1	1	1	
23	Control Box Cover		454838-01	1	1	1	1	1	1	1	1	
24	Sliding Door Assembly (includes items 25 through 28a)		341381A01	1	1	1	1	1	1	1	1	
25	Sliding Door		454860-01	1	1	1	1	1	1	1	1	
26	Sliding Plate		454861-01	1	1	1	1	1	1	1	1	
27	Sliding Collar		454862-01	1	1	1	1	1	1	1	1	
28	Knob		444301-02	1	1	1	1	1	1	1	1	
28a	Hex Head Bolt	4x12, SS	7B02-0412	2	2	2	2	2	2	2	2	

Title: A. Main Assembly Model: F-300BAF												
Index No.	Description	Material or Model Number	Part Number	Required Number								
				H-0	J-0 to K-1	K-2 to M-0	M-1 to S-0	S-1 to T-0	T-1 to V-1	V-2 to A-0	A-1 to F-0	
Refrigeration Circuit												
29	Compressor		4A1177-01	1	-							
			4A2272-01		1	1	-					
			4A4614-01				1	1	1	1	1	
30	Condenser		228236-01	1	1	1	1	1	1	1	1	
31	Fan Motor		4A0815-01	1	1	1	1	1	1	1	1	
32	Fan Blade		3A0608-01	1	1	1	1	1	1	1	1	
32a	Hex Nut		4A1345-01	1	1	1	1	1	1	1	1	
33	Thermostatic Expansion Valve		4A1117-01	1	1	1	1	1	1	1	1	
34	Thermostatic Expansion Valve Cover		4A1168-01	1	1	1	1	1	1	1	1	
35	Heat Exchanger		228835G01	1	-							
			2A1936G01		1	1	-					
			2A4961G01				1	1	1	1	1	
36	High-Pressure Switch		433441-05	1	1	1	1	1	1	1	-	
			463180-05									1
37	Drier		4A1113-01	1	1	1	1	1	1	1	1	
38	Power Supply Cord		4A1773-01	1	1	1	1	1	1	1	1	

B. Icemaking Unit
F-300BAF
H-0 to F-0

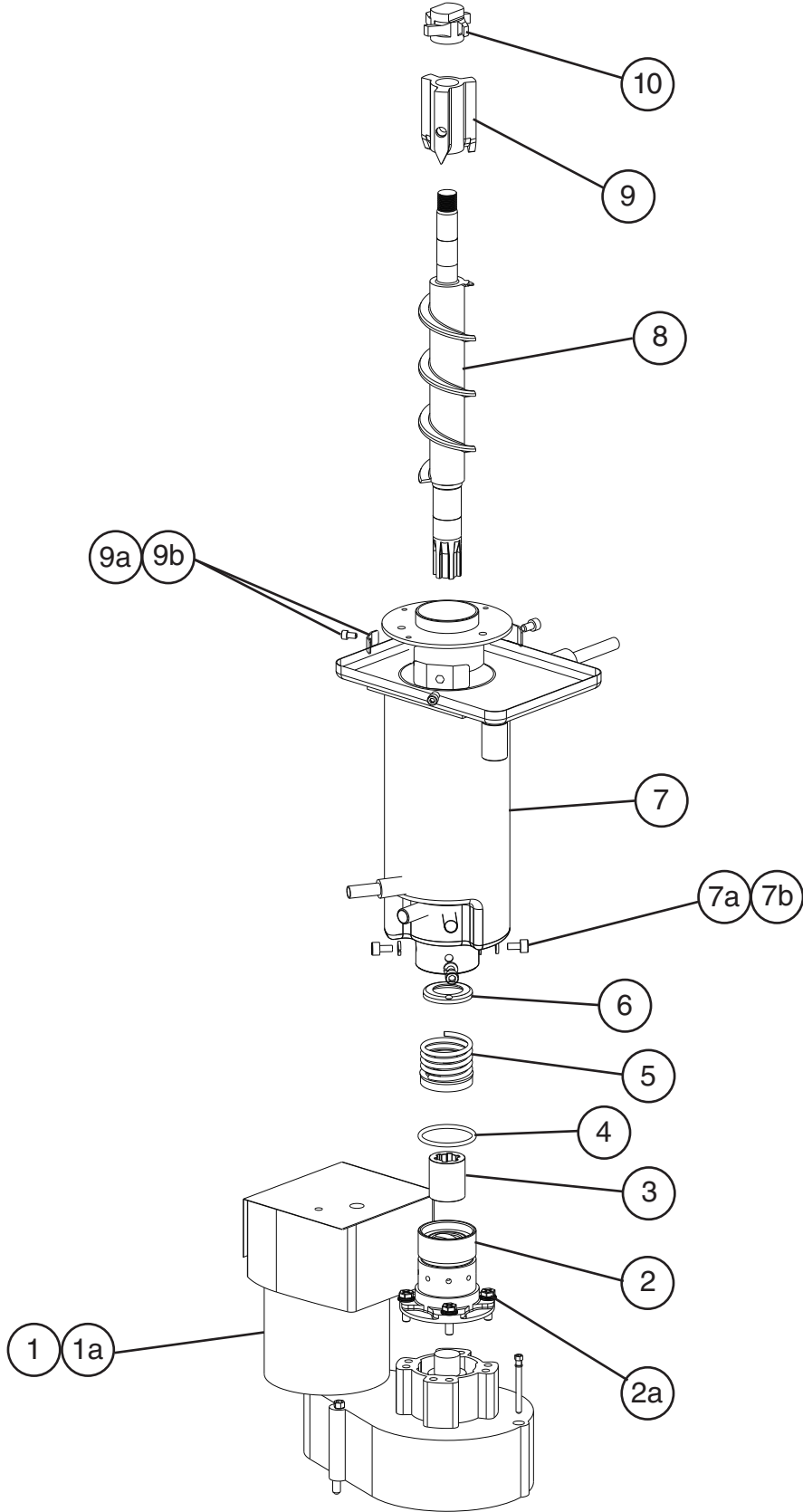

Title: B. Icemaking Unit Model: F-300BAF

Index No.	Description	Material or Model Number	Part Number	Required Number									
				H-0 to K-2	L-0 to P-1	Q-0 to S-0	S-1 to U-0	U-1 (B-H)	U-1 (J) to V-1	V-2 to C-0	C-1 to F-0		
1	Gear Motor		SA0103	1	1	1	-						For auxiliary codes K-1 and earlier, you must also order Fuse Holder 4A0892-02, Fuse 4A0893-04, and Fuse Holder Adapter 4A1880-01. For details, see Hoshizaki Service Bulletin SB08-0006.
			2U0147-01				1	1	1	1	-		
			4A5439-01									1	
1a	Hex Head Bolt	8x30, SS	7B02-0830	3	3	3	3	-					
	Socket Head Cap Screw	8x95, SS	7S12-0895					3	3	3	3		
2	Housing		206013G03	1	1	1	1	1	1	1	1		
2a	Hex Bolt	6x20, SS	7B02-0620	4	-								
			458660-01		4	4	4	-					
			4A1989-01					4	4	4	4		
3	Spline Coupling		418316-01	1	1	1	1	1	1	1	1		
4	O-Ring		7616-G040	1	1	1	1	1	-				
			4A4755-01						1	1	1		
5	Mechanical Seal		432491-01	1	1	1	1	1	1	1	1		
6	Ring		432494-01	1	1	1	1	1	1	1	1		
7	Evaporator		341456G01	1									
			2A1722G01		1	-							
			2A3308G01			1	1	1	1	1	1	1	
7a	Socket Head Cap Screw	6x10, SS	7S12-0610	4	4	4	4	4	4	4	4		
7b	Split Lock Washer	M6, SS	7L22-0600	4	4	4	4	4	4	4	4		
8	Auger		341446G01	1	-								
			361013G01		1	1	1	1	1	1	1	1	
9	Extruding Head		340077G01	1	1	1	1	1	1	1	1		
9a	Seal Bolt		P01768-01	3	3	3	3	3	3	3	3		
9b	Washer		453791-01	3	3	3	3	3	3	3	3		
10	Cutter		453790-01	1	1	1	1	1	1	1	1		

C. Water Circuit
F-300BAF
 H-0 to F-0

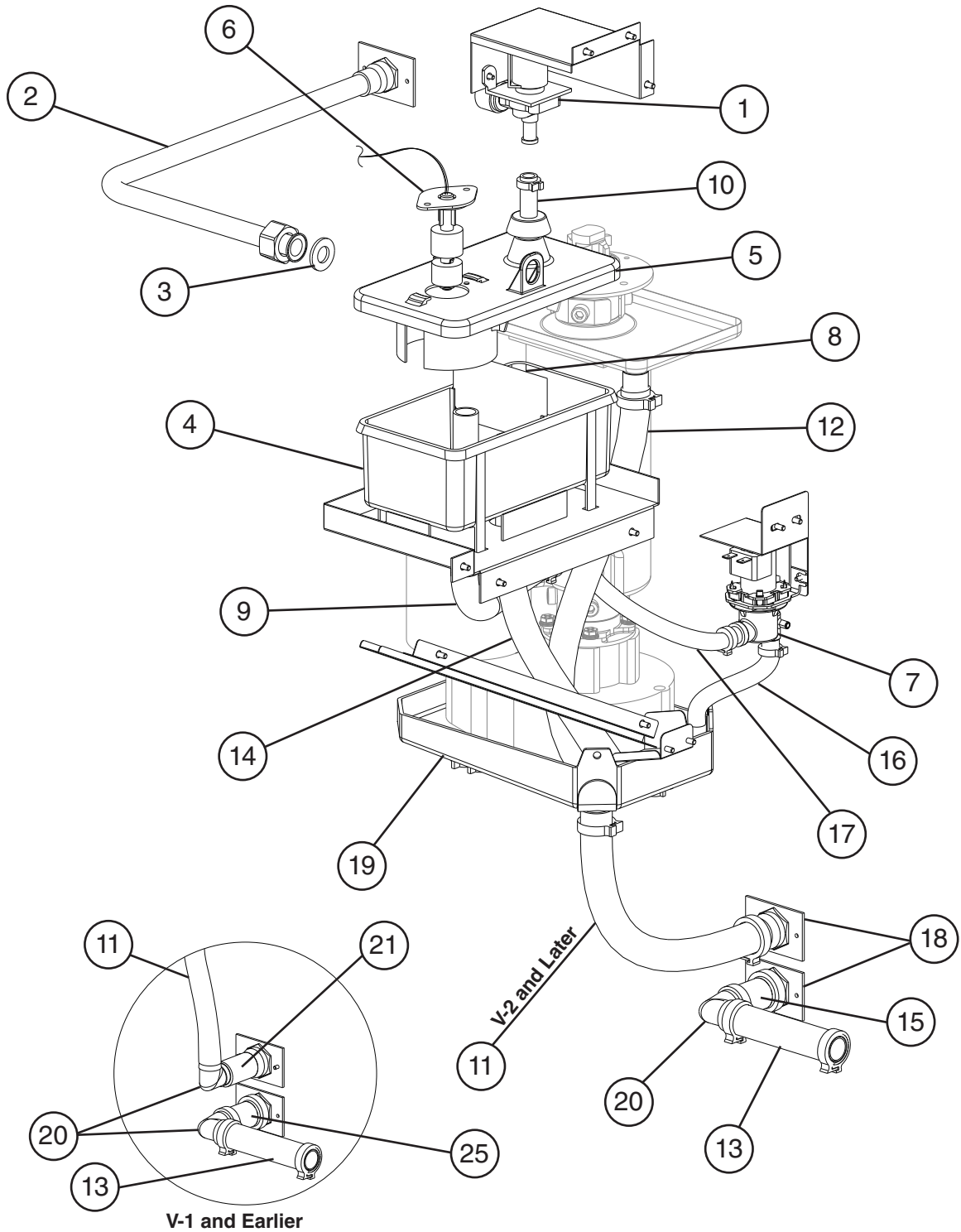

Title: C. Water Circuit Model: F-300BAF

Index No.	Description	Material or Model Number	Part Number	Required Number								
				H-0 J-0	J-1	K-0 to L-1	M-0 to S-0 (H)	S-1 (J) to V-1	V-2 to B-0	B-1 to C-0	C-1 to F-0	
1	Inlet Water Valve		4A0865-01	1	1	1	1	1	1	1	-	
			4A5309-01								1	1
2	Water Supply Pipe		341367G01	1	1	1	1	1	1	1	-	
			341367G02								1	1
3	Washer		4A0867-01	1	1	1	1	1	1	1	1	1
4	Reservoir		2A0753-01	1	1	1	1	1	1	1	1	1
5	Reservoir Cover		214810-01	1	1	1	1	1	1	1	1	1
6	Float Switch		435490-01	1	1	1	1	1	1	1	1	1
7	Drain Valve		4A0866-01	1	1	-						
			4A5309-01			1	-	-				
			4A2772-01				1	1	1	1	1	1
8	Reservoir Separator		4A1255-01	1	1	1	1	1	1	1	1	1
9	Reservoir Hose		4A1165-05	1	1	1	1	-				
			4A1165-09					1	1	1	1	1
10	Reservoir Inlet		4A0869-01	1	1	1	1	1	1	1	1	1
11	Vinyl Hose	L=165 mm	7725-1923	1	1	1	-					
			7716-2025				1	1	-			
		L=385 mm							1	1	1	
12	Vinyl Hose	L=360 mm	7725-1923	1	1	1	1	1	-			
		L=345 mm							1	1	1	
13	Vinyl Hose	L=100 mm	7716-2025				1	1	1	1	1	1
14	Vinyl Hose	L=300 mm	7725-1923	1	1	1	1	1	-			
		L=285 mm							1	1	1	
15	Vinyl Hose	L=45 mm	7725-1923	1	1	1	-					
		L=50 mm	7716-1025				1	1	1	1	1	1
16	Silicone Hose	L=150 mm	773013896	1	1	1	1	1	1	1	1	1
17	Vinyl Hose	L=360 mm	7725-0912	1	1	-						
	Silicone Hose		773013896			1	1	1	-			
		L=300 mm							1	1	1	
18	Drain Fitting		4A0776G01	2	2	2	2	2	2	2	-	
			4A5527-01									
19	Drain Pan		341376G01	1	1	1	1	1	-			
			323765G01							1	1	1
20	Elbow		4A1017-01	2	2	2	2	2	1	1	1	1
21	Vinyl Hose	L=70 mm	7725-1923	1	1	1	1	1	-			
Hose Clamps												
	Hose Clamp	16 mm	435934-06	1	-							
	Clamp	12-13.5 mm	421642-04	2	-							
	Clamp	22-25 mm	421642-09	4	-							
	Hose Clamp	17 mm	435934-05	1	-							
	Hose Clamp	26.2 mm	4A2017-01		6	6	7	7	6	6	6	
	Hose Clamp	30.2 mm	4A2017-02		4	4	3	3	2	2	2	
	Hose Clamp	13.5 mm	4A2017-04		3	-						
	Hose Clamp	15.1 mm	4A2017-08			3	3	3	4	4	4	
	Hose Clamp	20.6 mm	4A2017-05		1	1	1	1	1	1	1	
	Hose Clamp	22.2 mm	4A2017-06		1	1	1	1	1	1	1	

D. Control Box Assembly
F-300BAF
1/2
 H-0 to L-0

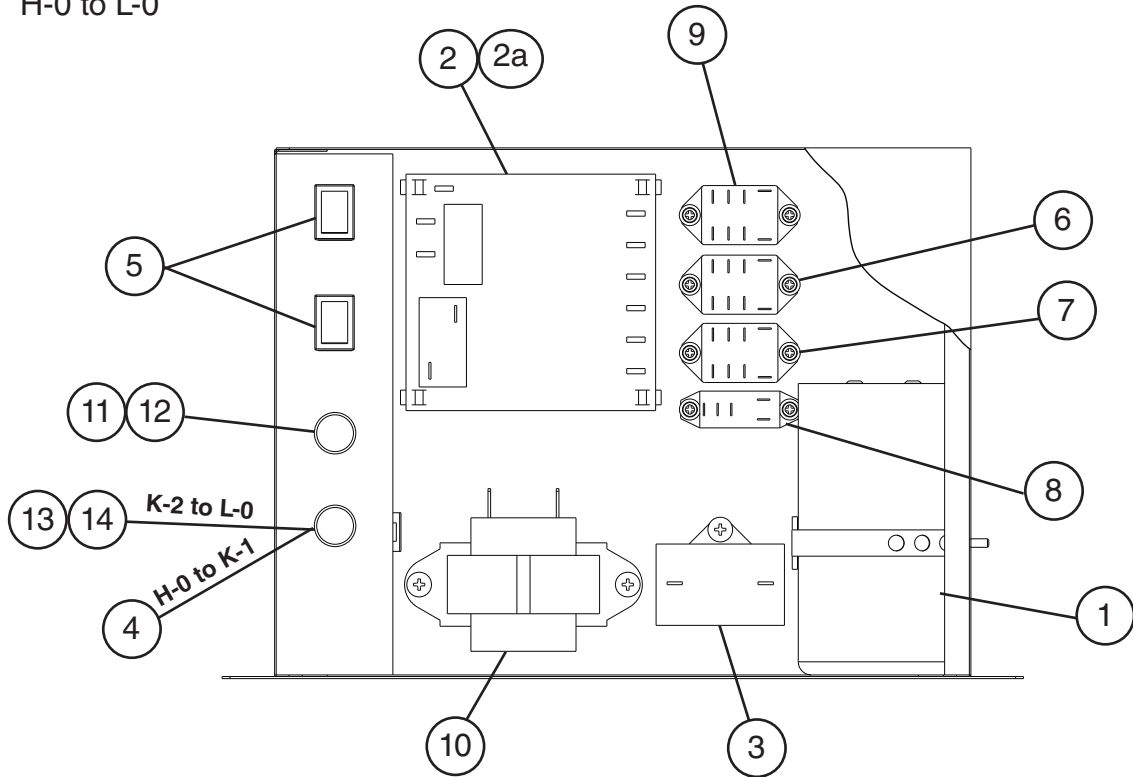

D. Control Box Assembly
F-300BAF
2/2
 L-1 to F-0

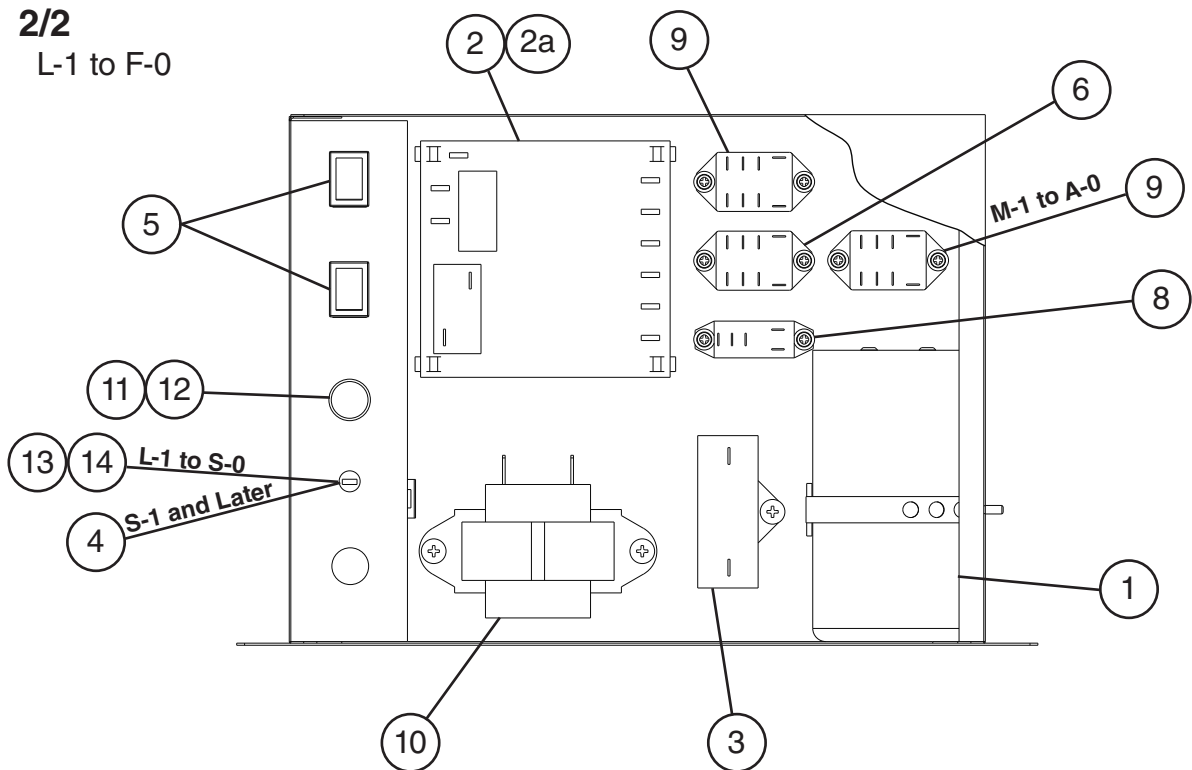

Title: D. Control Box Assembly Model: F-300BAF

Index No.	Description	Material or Model Number	Part Number	Required Number								
				H-0 to K-1	K-2 L-0	L-1 M-0	M-1 to S-0	S-1 to A-0	A-1 to C-0	C-1	C-2 to F-0	
1	Start Capacitor		3A0076-01									
2	Control Board (timer board)		437305-01	1	1	1	1	1	1	1	1	-
			4A5591-01									1
2a	Control Board Support		4A0336-03									
3	Gear Motor Capacitor	12MFD, 330VAC	4A0894-01	1	1	1	1	-				
		10MFD, 280VAC	416921-05					1	1	-		
		10MFD, 250VAC	443192-01								1	1
4	Gear Motor External Protector		440972-02	1	-							
			427253-01					1	1	1	1	
5	Rocker Switch (Control and Power Switch)		4A0558-01	2	2	2	2	2	2	2	2	
6	Gear Motor Protect Relay		406132-07	1	1	1	1	1	1	1	1	
7	Circuit Protect Relay		418271-05	1	1	-						
8	Drain Relay (Flush Relay)		430173-03	1	1	1	1	1	1	1	1	
9	Water Control Relay and Safety Relay		406132-06	1	1	1	2	2	1	1	1	
10	Control Transformer		4A0557-01	1	1	1	1	1	1	1	1	
11	Fuse Holder		4A0892-01	1	1	1	1	1	-			
			4A3449-01						1	-		
			4A5443-01								1	1
12	Control Board Fuse	AGC-1A, 250VAC	4A0893-01	1	1	1	1	1	1	1	1	
13	Fuse Holder		4A0892-02		1	1	1	-				
14	Gear Motor Fuse	GMD1.5A, 250VAC	4A0893-04		1	1	1	-				

E. Accessories & Labels
F-300BAF
H-0 to F-0

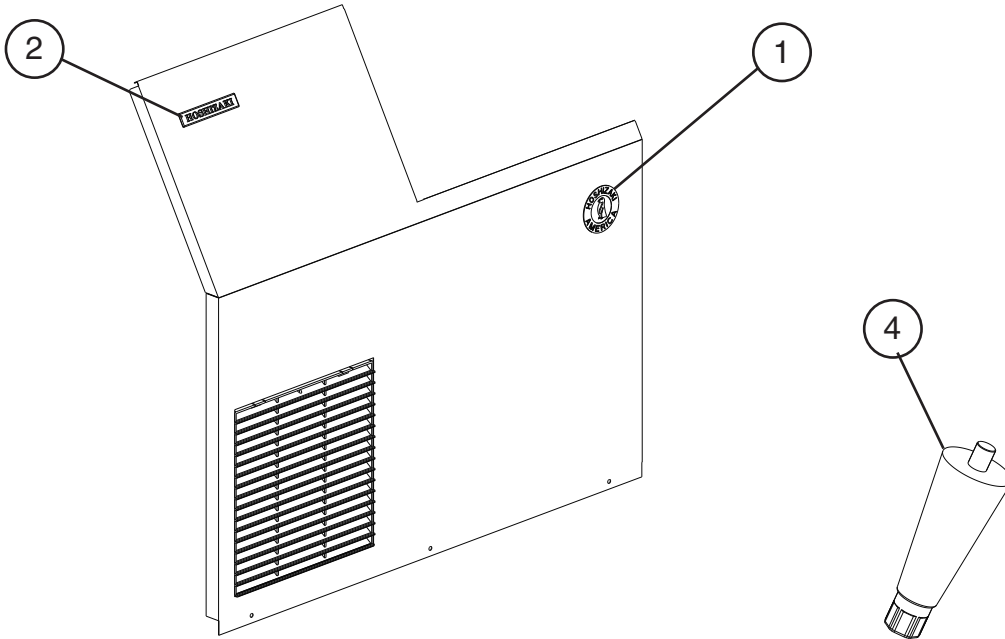

Title: E. Accessories & Labels Model: F-300BAF											
Index No.	Description	Material or Model Number	Part Number	Required Number							
				H-0 to J-1	K-0 to Q-0	Q-1 to F-0					
1	Penguin Label		4A0526-01	1	1	1					
2	Hoshizaki Emblem		4A0560-01	1	1	1					
3	Scoop		437625-01	1	-						
			4A2246-01		1	1					
4	Adjustable Leg		434043-01	4	4	-					
			4A2525-01			4					