



HOSHIZAKI

Parts List

Self-Contained Flaker

Models

F-330BAH(-C)



hoshizakiamerica.com

Number: 71268
Issued: 9-27-2007
Revised: 7-28-2017

CONTENTS

Auxiliary Codes.....	3
Note About Ordering Parts	4
A. Main Assembly	5
B. Refrigeration Circuit.....	7
C. Icemaking Unit	9
D. Water Circuit	11
E. Control Box Assembly.....	14
F. Accessories & Labels.....	17

Auxiliary Codes

F-330BAH

S-0	April 2007
S-1	October 2007
T-0	January 2008
U-0	January 2009
V-0	January 2010
V-1	May 2010
V-2	August 2010
A-0	February 2011
B-0	January 2012
B-1	March 2012
B-2	December 2012
C-0	January 2013
C-1	March 2013
C-2	April 2013
C-3	June 2013
D-0	January 2014
D-1	December 2014
E-0	January 2015
F-0	January 2016

F-330BAH-C

T-0	January 2008
U-0	January 2009
V-0	February 2010
V-1	May 2010
V-2	December 2010
A-0	January 2011
B-0	January 2012
B-1	March 2012
C-0	January 2013
C-1	March 2013
C-2	April 2013
C-3	June 2013
D-0	January 2014
D-1	December 2014
E-0	January 2015
F-0	January 2016

Auxiliary Code Breakdown

The auxiliary code is the first two characters in the serial number. The first character indicates the year. Years progress or regress in alphabetical order. The series runs from "A" through "V" and the letters "I" and "O" are skipped. The second character indicates significant part changes within a year. Base is "0" and this number advances for each change. In cases where there is a letter in parentheses, this designates the month. This is the last character in the serial number. The series runs from "(A)" through "(M)" and the letter "(I)" is skipped. This designation is only included when identifying a parts change within an auxiliary code.

Note About Ordering Parts

Most assemblies cannot be ordered as complete units; parts in the assemblies generally must be ordered separately.

A. Main Assembly
F-330BAH(-C)
S-0 to F-0

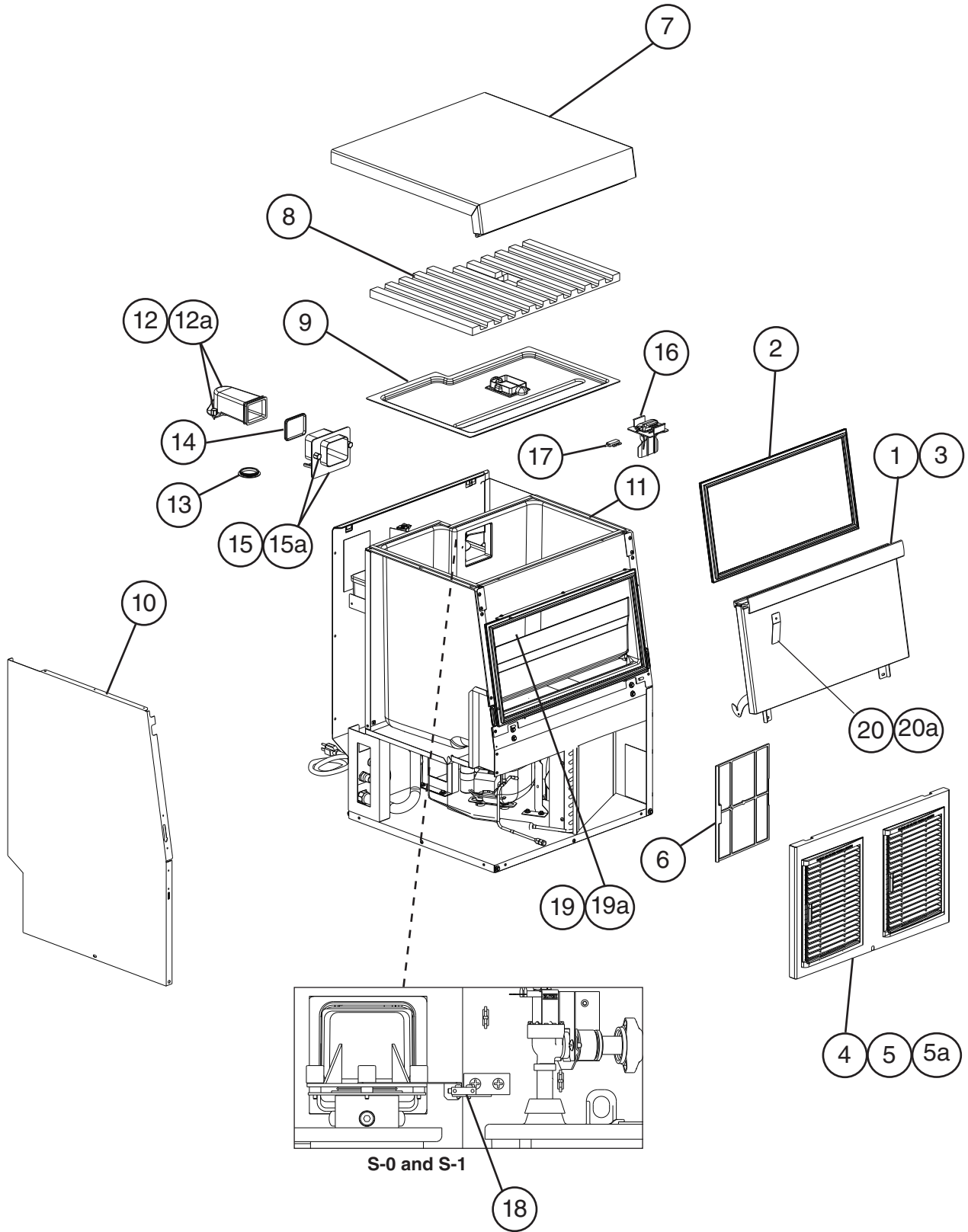

Title: A. Main Assembly Model: F-330BAH(-C)												
Index No.	Description	Material or Model Number	Part Number	Required Number								
				S-0 to S-1	T-0 to C-2	C-3 to D-1	E-0 F-0					
Main Assembly												
1	Door		3A4357A01	1	1	1	-					
			1A3657A01				1					
2	Door Gasket		2A6198-01	1	1	1	1					
3	Door Handle		2A3361-01	1	1	1	1					
4	Front Panel		1A1306-01	1	-							
			3A4295G01		1	1	1					
5	Louwer		1A0548-01	2	2	2	2					
5a	Push Retainer		4A2414-01	6	6	6	6					
6	Air Filter		2A2063G01	1	1	1	1					
7	Top Panel		1A1307-01	1	1	1	1					
8	Top Insulation		1A1304-01	1	1	1	1					
9	Upper Panel		1A1303-01	1	1	1	1					
10	Left Side Panel		2A4079-01	1	1	1	1					
11	Righ Side Panel		2A4080-01	1	1	1	1					
12	Spout (A)		208791-02	1	1	1	1					
12a	Thumbscrew		415949G11	3	3	3	3					
13	Packing		427151-01	1	1	1	1					
14	Spout Packing		453663-01	1	1	1	1					
15	Spout (B)		232654-03	1	1	1	1					
15a	Thumbscrew		415949G11	2	2	2	2					
16	Actuator		350301A02	1	1	1	1					
17	Bin Control (Reed Switch)		453861-02	1	1	1	1					
18	Microswitch (Safety Switch)		4A2832-01	1	-							
19	Slope		2A4259-01	1	1	1	1					
19a	Thumbscrew		415949G10	1	1	1	1					
20	Slope Hook		4A3700-01	1	1	1	-					
			4A5807-01				1					
20a	Thumbscrew		415949G10	1	1	1	1					

B. Refrigeration Circuit
F-330BAH(-C)
S-0 to F-0

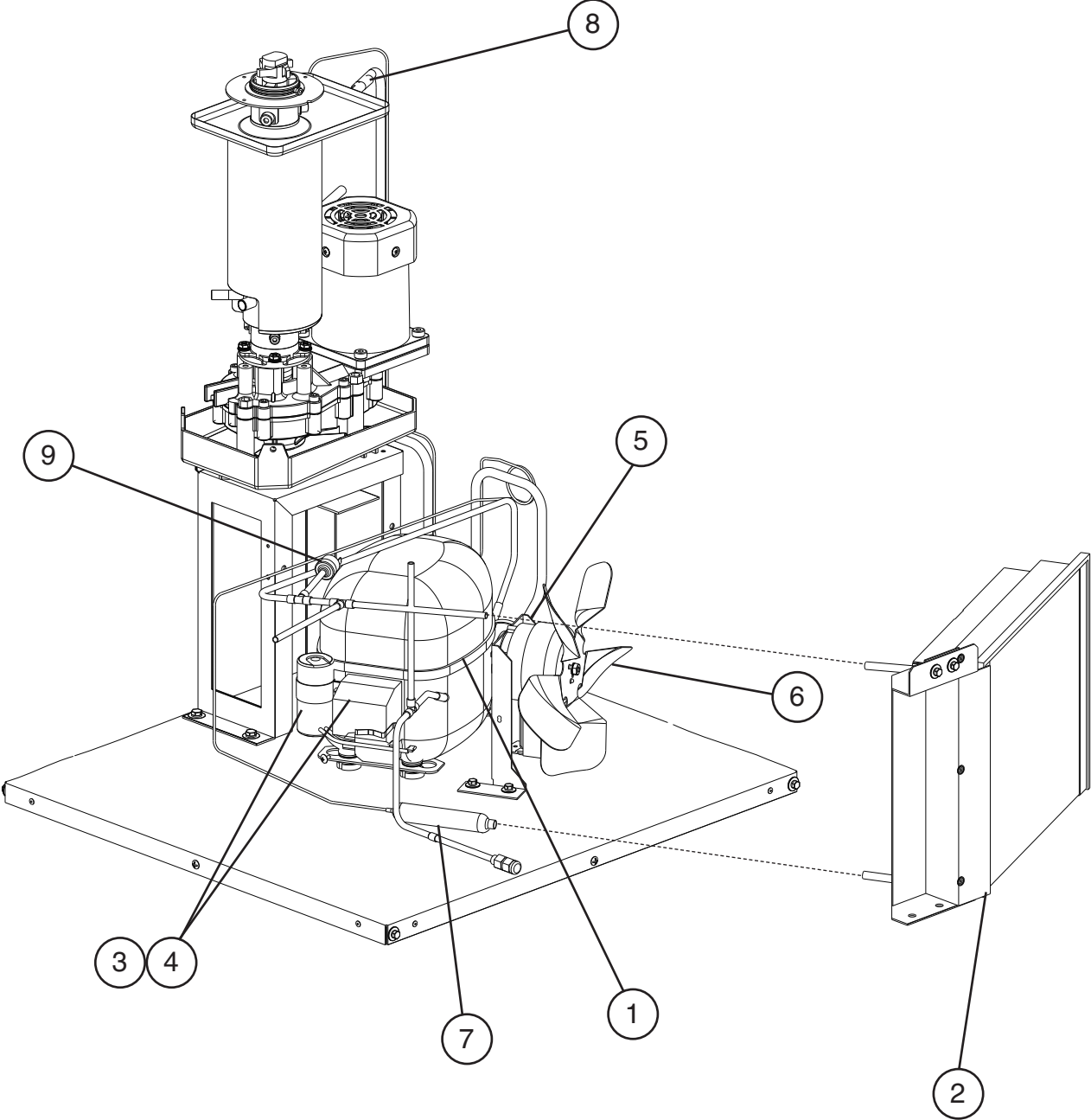

Title: B. Refrigeration Circuit Model: F-330BAH(-C)													
Index No.	Description	Material or Model Number	Part Number	S-0 to F-0	Required Number								
1	Compressor		4A4185-01	1									
2	Condenser		3A4309-01	1									
3	Start Relay		4A4232-01	1									
4	Start Capacitor	320MFD	4A2134-04	1									
5	Fan Motor		4A0408-01	1									
6	Fan Blade		3A0608-01	1									
7	Drier		445655-04	1									
8	Heat Exchanger		2A4069G01	1									
9	High-Pressure Switch		463180-04	1									

C. Icemaking Unit
F-330BAH(-C)
 S-0 to F-0

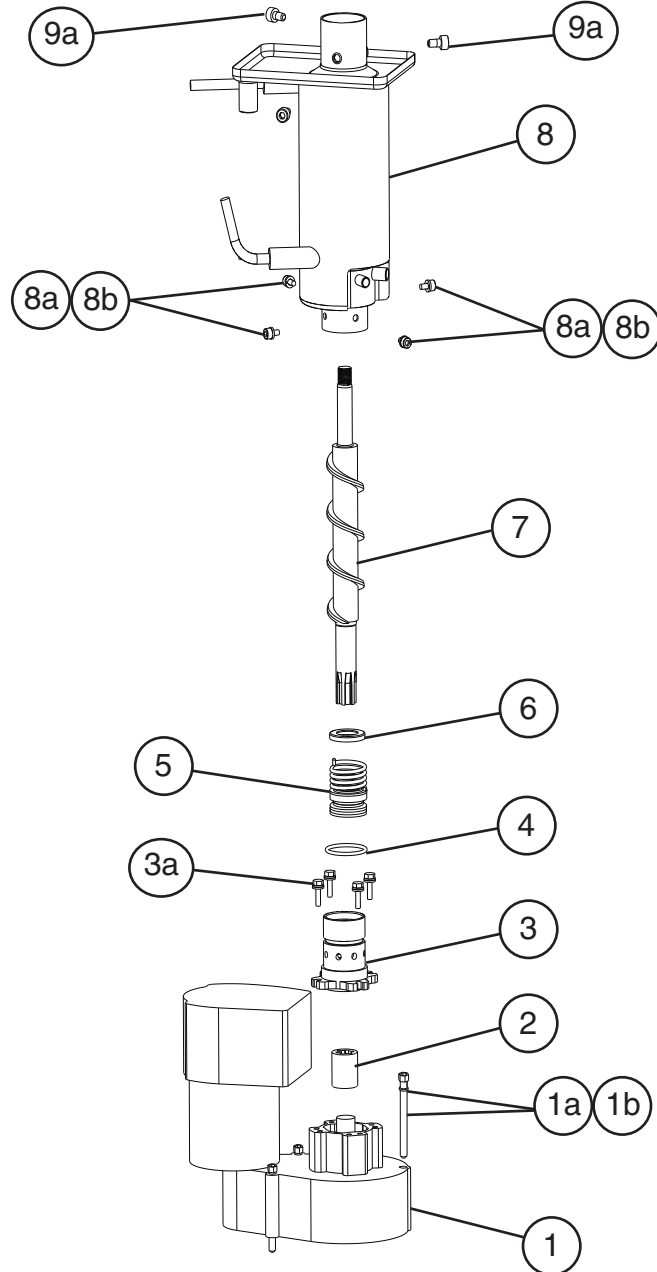
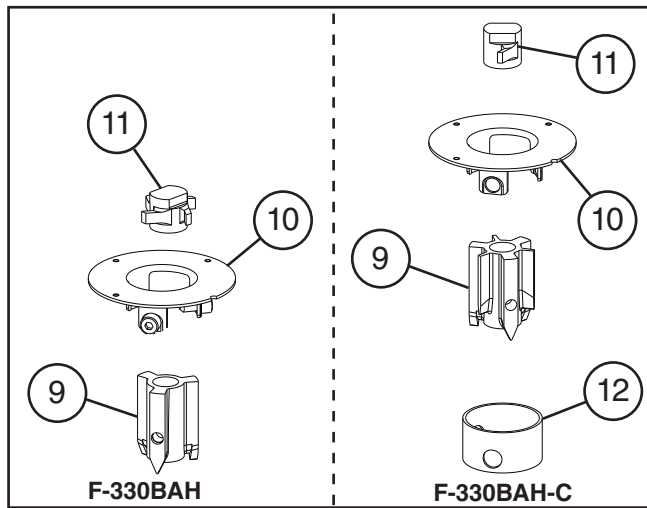

Title: C. Icemaking Unit Model: F-330BAH(-C)											
Index No.	Description	Material or Model Number	Part Number	Required Number							
				S-0 to S-1	T-0 to V-0	V-1 to C-0	C-1 to F-0				
1	Gear Motor		2U0147-01	1	1	1	-				
			4A5439-01				1				
1a	Socket Head Cap Screw		7S12-0811	3	3	3	3				
1b	Split Lock Washer		7L22-0800	3	3	3	3				
2	Spline Coupling		418316-01	1	1	1	1				
3	Housing		206013G03	1	1	1	1				
3a	Bolt		4A1989-01	4	4	4	4				
4	O-Ring		7616-G040	1	1	-					
			4A4755-01			1	1				
5	Mechanical Seal		432491-01	1	1	1	1				
6	Ring (B)		432494-01	1	1	1	1				
7	Auger		361013G01	1	1	1	1				
8	Evaporator		2A4076G01	1	1	1	1				
8a	Split Lock Washer	M6, SS	7L22-0600	4	4	4	4				
8b	Socket Head Cap Screw	6x10, SS	7S12-0610	4	4	4	4				
9	Extruding Head	F-330BAH	340077G01	1	1	1	1				
		F-330BAH-C	327141G01		1	1	1				
9a	Seal Bolt		P01768-01	3	3	3	3				
10	Flange		464843-01	1	1	1	1				
11	Cutter	F-330BAH	453790-01	1	1	1	1				
		F-330BAH-C	440905-01		1	1	1				
12	Evaporator Heater	F-330BAH-C	4A4375-01		1	1	1				

D. Water Circuit
F-330BAH(-C)
1/2
 S-0 to D-0

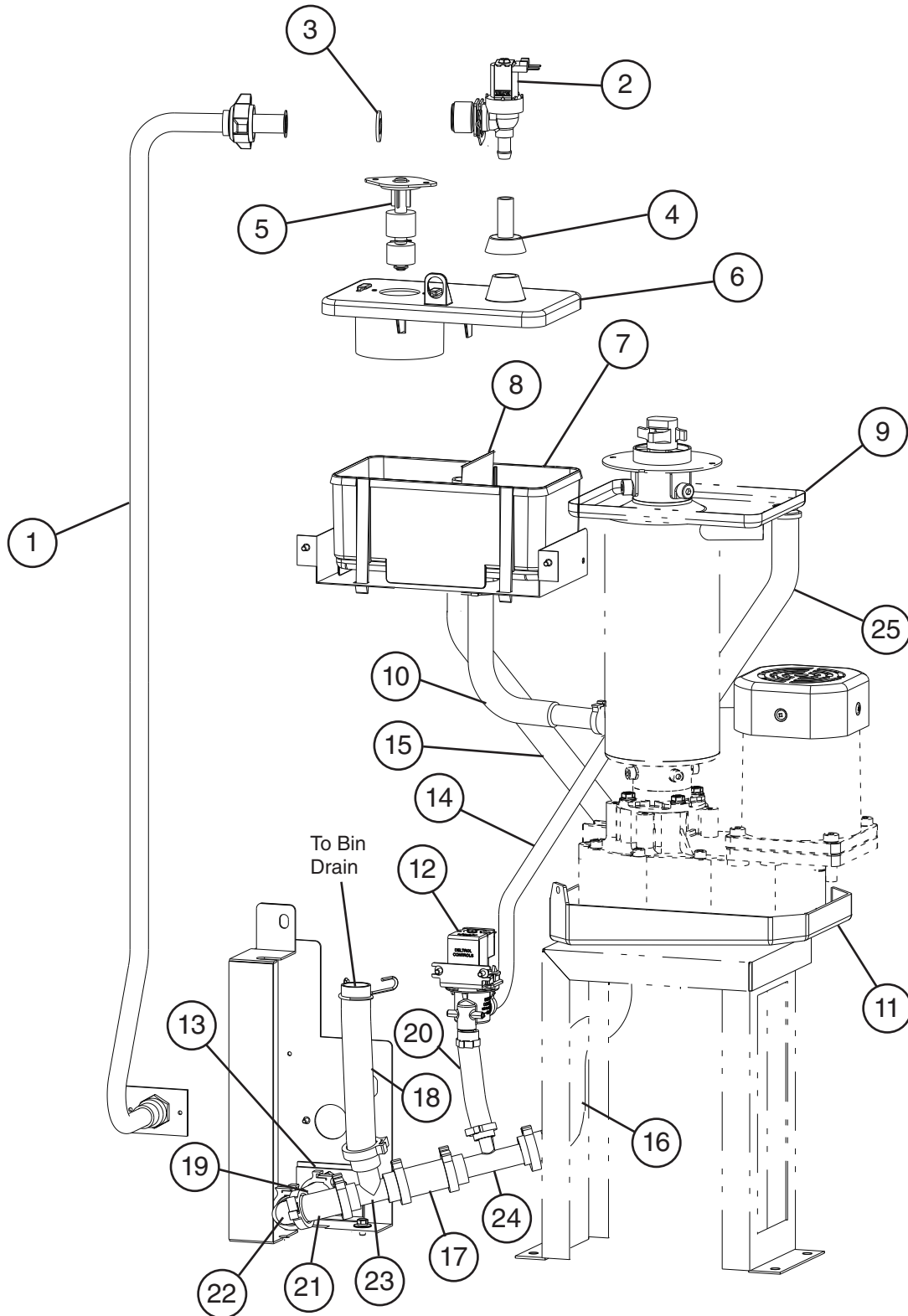

D. Water Circuit
F-330BAH(-C)
2/2
D-1 to F-0

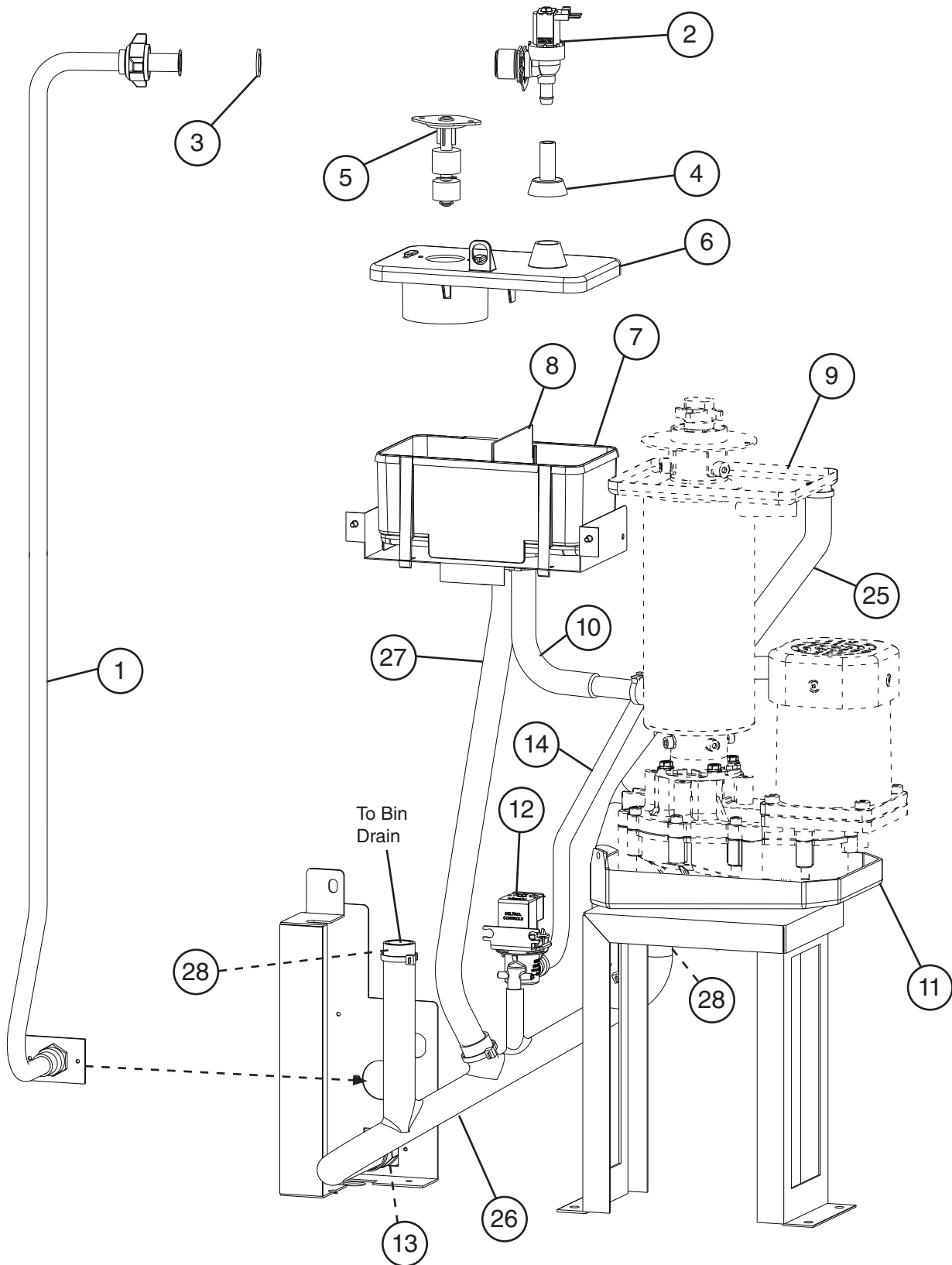

Title: D. Water Circuit Model: F-330BAH(-C)												
Index No.	Description	Material or Model Number	Part Number	Required Number								
				S-0 to B-0	B-1	B-2 to D-0	D-1 to F-0					
1	Water Supply Pipe		3A4298G01	1	-							
			3A4298G02		1	1	1					
2	Inlet Water Valve		4A0865-01	1	-							
			4A5309-01		1	1	1					
3	Rubber Gasket		413854-03	1	1	1	1					
4	Reservoir Inlet		4A0869-01	1	1	1	1					
5	Float Switch		435490-01	1	1	1	1					
6	Reservoir Cover		214810-01	1	1	1	1					
7	Reservoir		2A0753-01	1	1	1	1					
8	Reservoir Separator		4A1255-01	1	1	1	1					
9	Drip Pan		427213G02	1	1	1	1					
10	Reservoir Hose		4A1165-04	1	1	1	1					
11	Drain Pan		323765G01	1	1	1	1					
12	Drain Valve		4A2772-02	1	1	1	1					
13	Drain Fitting		4A0776G02	1	1	-						
			4A5527-01			1	1					
14	Silicone Hose	L=390 mm	773013896	1	1	1	1					
15	Vinyl Hose	L=330 mm	7716-2025	1	1	1	-					
16	Vinyl Hose	L=190 mm	7716-2025	1	1	1	-					
17	Vinyl Hose	L=80 mm	7716-2025	1	1	1	-					
18	Vinyl Hose (bin drain hose)	L=160 mm	7716-2025	1	1	1	-					
19	Vinyl Hose	L=50 mm	7716-2025	1	1	1	-					
20	Vinyl Hose	L=60 mm	7716-1216	1	1	1	-					
21	Vinyl Hose	L=60 mm	7716-2025	1	1	1	-					
22	Elbow		4A1017-01	1	1	1	-					
23	Tee		4A2600-01	1	1	1	-					
24	Tee		4A1331-01	1	1	1	-					
25	Vinyl Hose	L=395 mm	7725-1923	1	1	1	-					
		L=545 mm					1					
26	Drain Hose		3A8113-01				1					
27	Vinyl Hose	L=475 mm	7725-1923				1					
28	Vinyl Hose	L=30 mm	7716-2025				2					
Hose Clamps												
	Hose Clamp		4A2017-08	3	3	1	1					
	Hose Clamp		4A2017-01	1	1	1	1					
	Hose Clamp		4A2017-05	2	2	2	2					
	Hose Clamp		4A2017-02	8	8	8	-					
	Hose Clamp		427443-03	1	1	1	-					
	Hose Clamp		4A2017-07	1	1	1	3					

E. Control Box Assembly F-330BAH(-C)

1/3

S-0

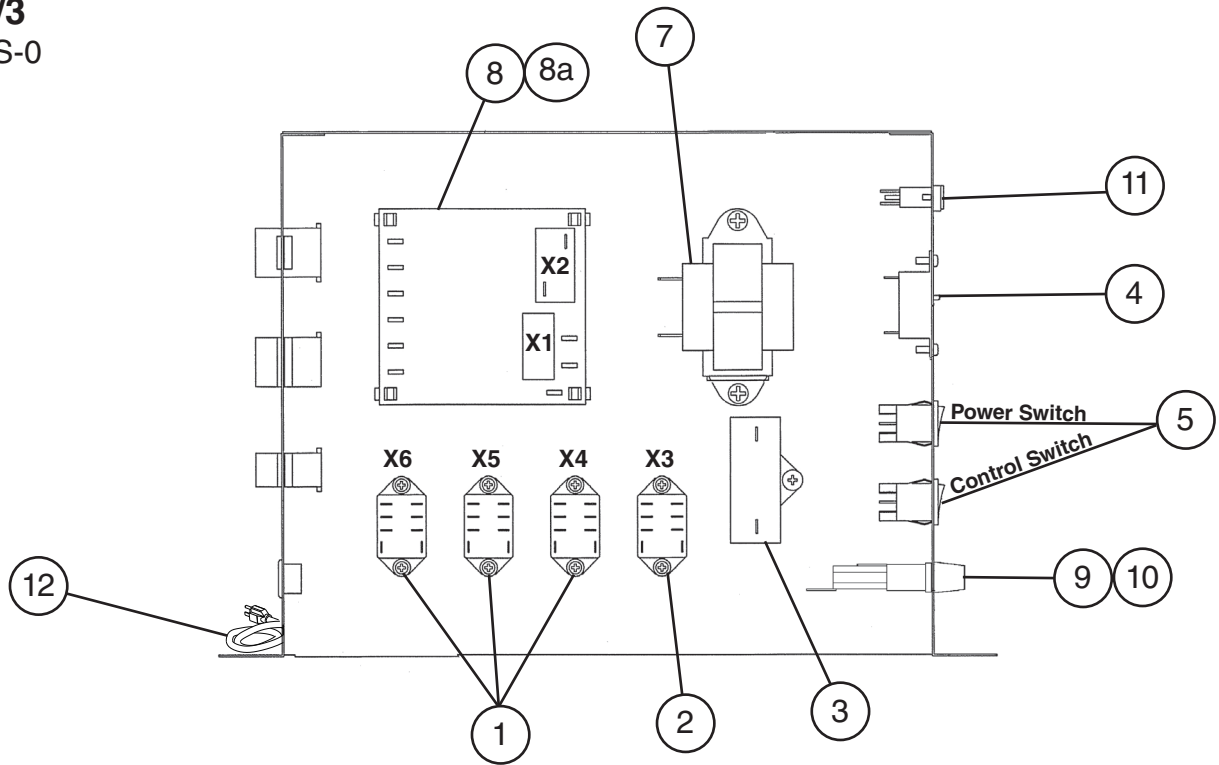

E. Control Box Assembly F-330BAH(-C)

2/3

S-1 to C-1

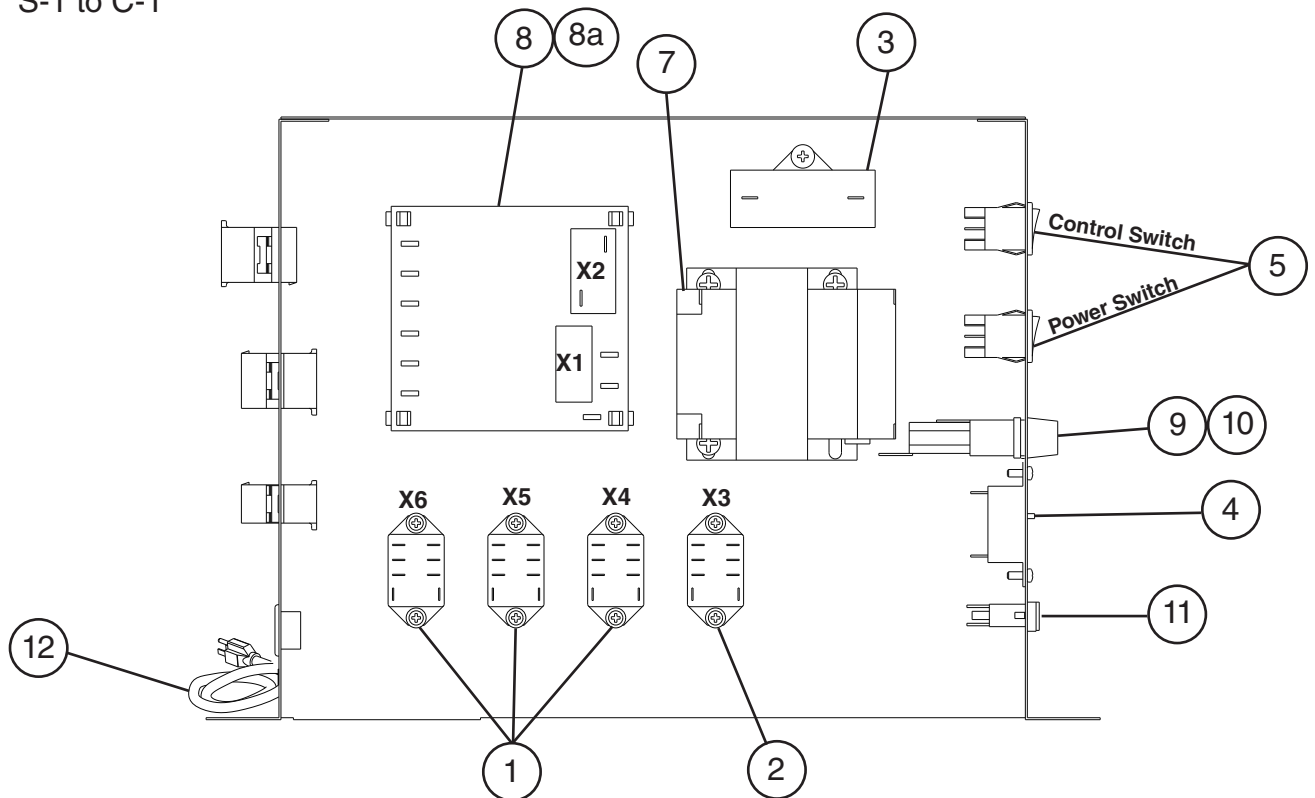

E. Control Box Assembly F-330BAH(-C)

3/3

C-2 to F-0

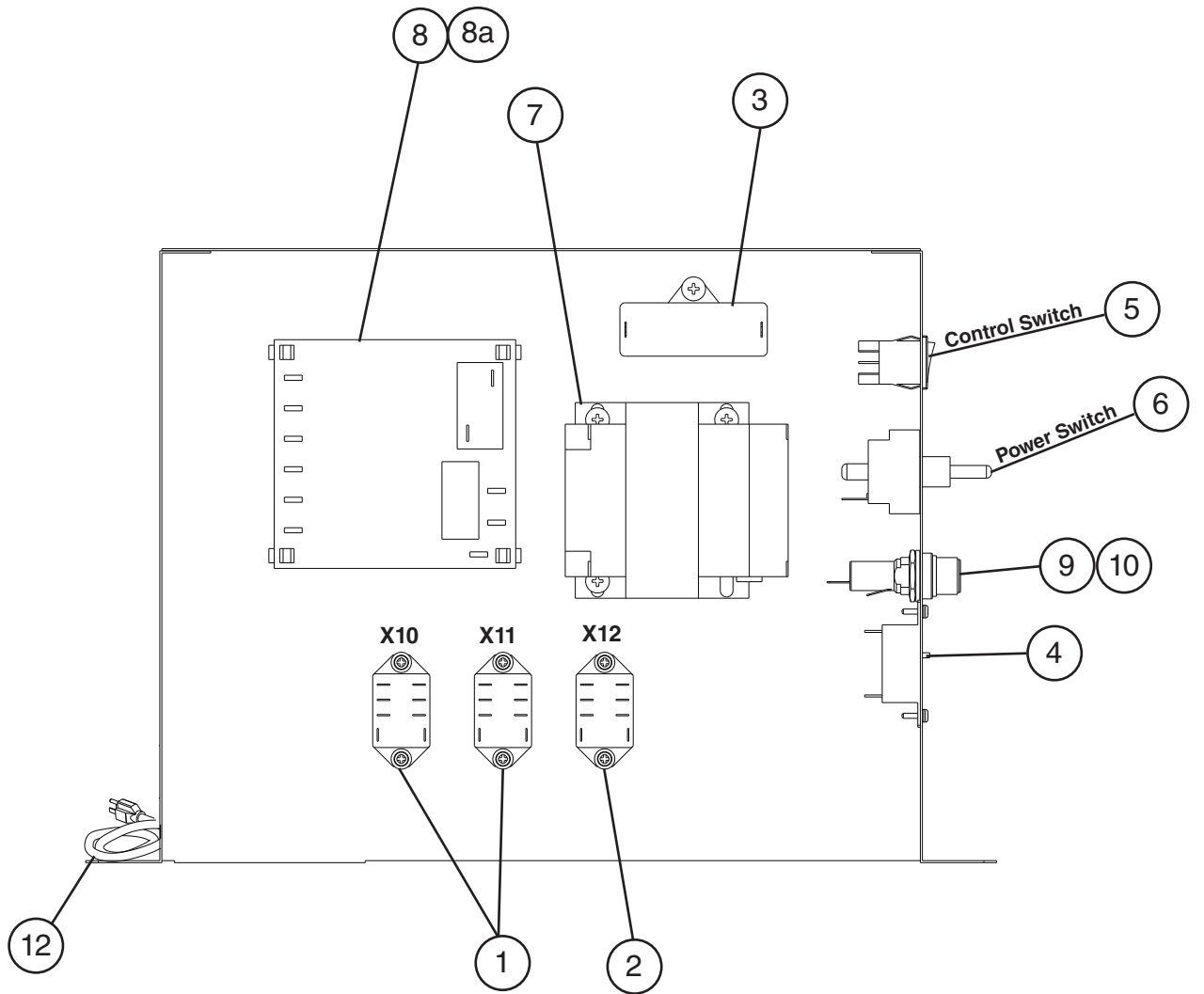

Title: E. Control Box Assembly Model: F-330BAH(-C)

Index No.	Description	Material or Model Number	Part Number	Required Number								
				S-0	S-1 to B-1	C-1	C-2 to F-0					
1	Relay (X4, X5, X6, X10, X11)	24VAC	406132-06	3	3	3	2					
2	Gear Motor Protect Relay (X3, X12)	120VAC	406132-07	1	1	1	1					
3	Gear Motor Capacitor	10MFD, 280VAC	416921-05	1	1	-						
			443192-01			1	1					
4	Protector		427253-01	1	1	1	1					
5	Control and Power Switch (Rocker Switch)		4A0558-01	2	2	2	1					
6	Power Switch (Toggle Switch)		4A2332-01				1					
7	Control Transformer		4A0557-01	1	-							
			4A0507-01		1	1	1					
8	Control Board		4A5591-01	1	1	1	1					
8a	Control Board Support		4A0336-03	4	4	4	4					
9	Fuse Holder		4A5443-01	1	1	1	1					
10	Fuse	AGC-1A, 250VAC	4A0893-01	1	1	1	1					
11	Lamp		4A2672-01	1	1	1	-					
12	Power Supply Cord		4A1773-01	1	1	1	1					

F. Accessories & Labels
F-330BAH(-C)
 S-0 to F-0

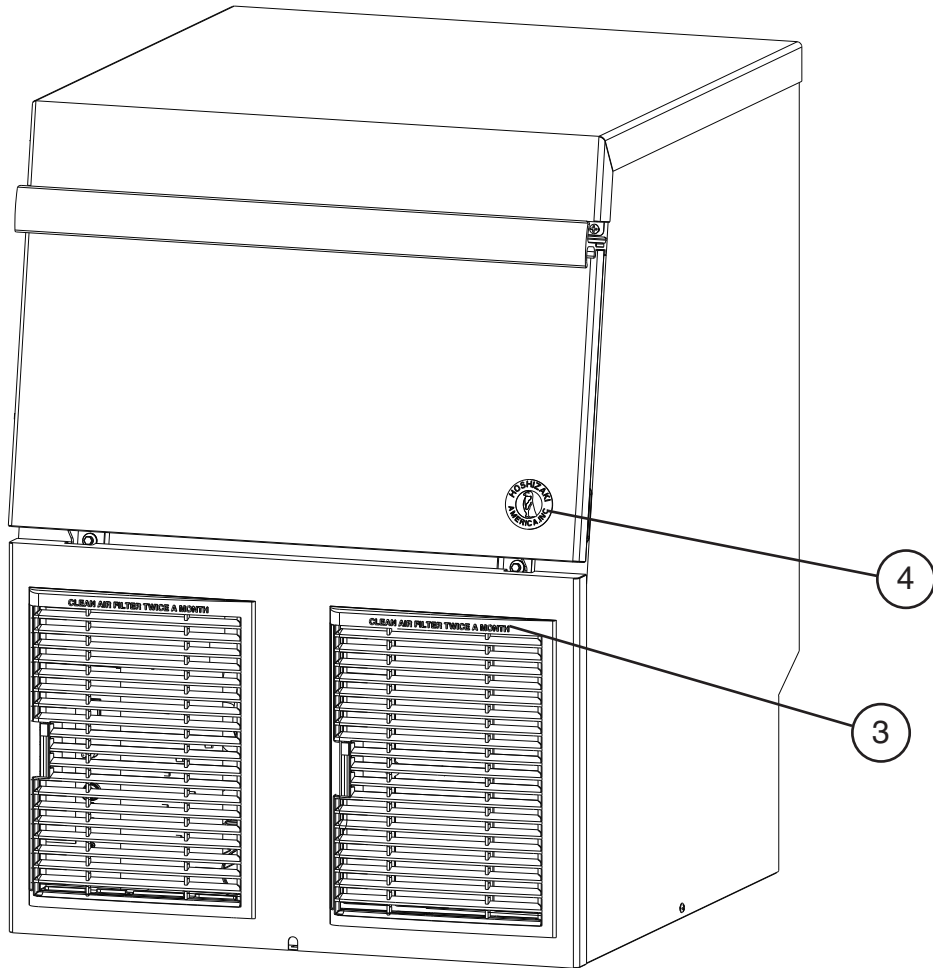

Title: F. Accessories & Labels Model: F-330BAH(-C)											
Index No.	Description	Material or Model Number	Part Number	Required Number							
				S-0 to D-0 (J)	D-0 (K) to F-0						
1	Scoop		443495-01	1	1						
2	Control Label		4A5152-01	1	1						
3	Air Filter Label		426177-01	1	-						
4	Penguin Label		456246-02	1	1						