



HOSHIZAKI

Parts List

Self-Contained Flaker

Model
F-500BAF



hoshizakiamerica.com

Number: 71127
Issued: 3-15-1999
Revised: 4-13-2016

CONTENTS

Auxiliary Codes.....	3
Note About Ordering Parts	3
A. Main Assembly	4
B. Refrigeration Circuit.....	7
C. Icemaking Unit	9
D. Water Circuit	11
E. Control Box Assembly.....	13
F. Accessories & Labels.....	15

Auxiliary Codes

F-500BAF

H-0	Septmeber 1998
J-0	December 1998
J-1	August 1999
K-0	January 2000
K-1	April 2000
L-0	March 2001
M-0	January 2002
M-1	October 2002
N-0	December 2002
P-0	December 2003
P-1	June 2004
Q-0	December 2004
Q-1	October 2005
R-0	December 2005
S-0	January 2007
S-1	November 2007
T-0	January 2008
U-0	January 2009
V-0	January 2010
V-2	May 2010
V-3	August 2010
A-0	January 2011
B-0	February 2012
C-0	February 2013
C-1	June 2013
D-0	April 2014
E-0	January 2015
F-0	January 2016

Auxiliary Code Breakdown

The auxiliary code is the first two characters in the serial number. The first character indicates the year. Years progress or regress in alphabetical order. The series runs from "A" through "V" and the letters "I" and "O" are skipped. The second character indicates significant part changes within a year. Base is "0" and this number advances for each change. In cases where there is a letter in parentheses, this designates the month. This is the last character in the serial number. The series runs from "(A)" through "(M)" and the letter "(I)" is skipped. This designation is only included when identifying a parts change within an auxiliary code.

Note About Ordering Parts

Most assemblies cannot be ordered as complete units; parts in the assemblies generally must be ordered separately.

A. Main Assembly
F-500BAF
 H-0 to F-0

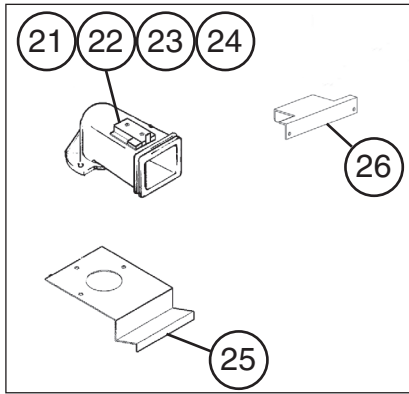

M-1 to A-0 (K)

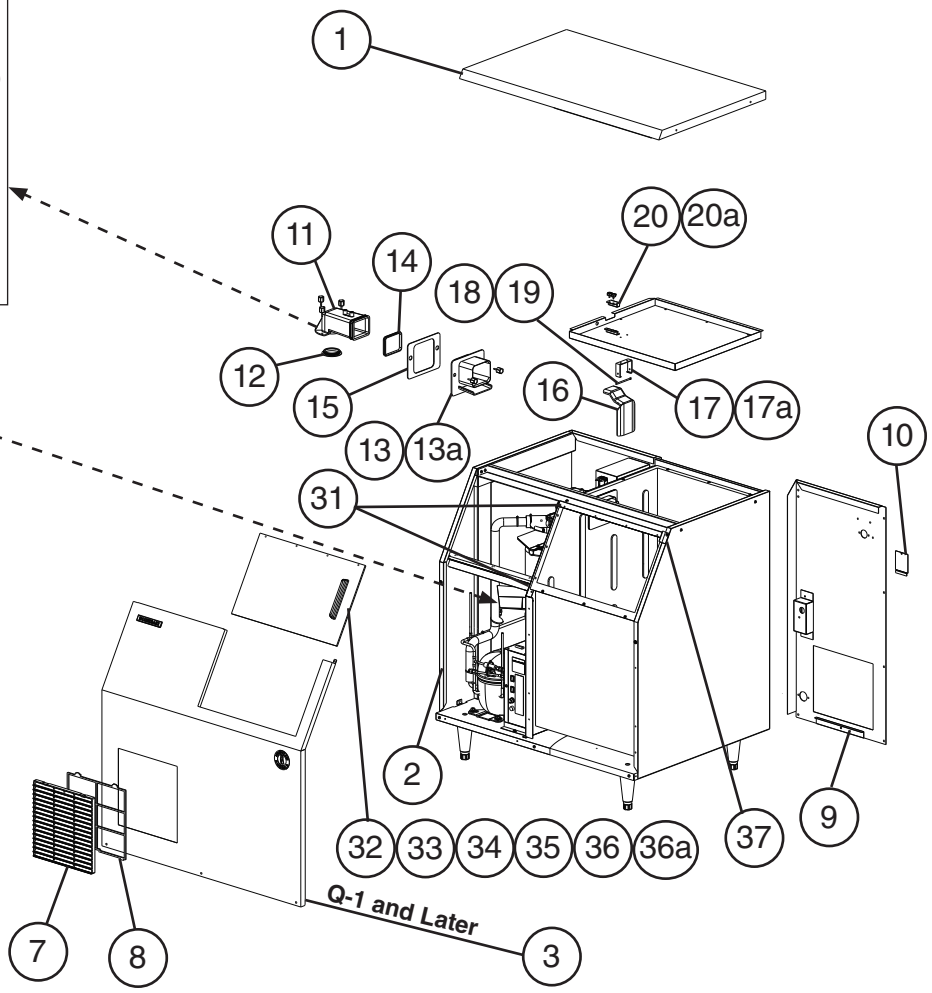
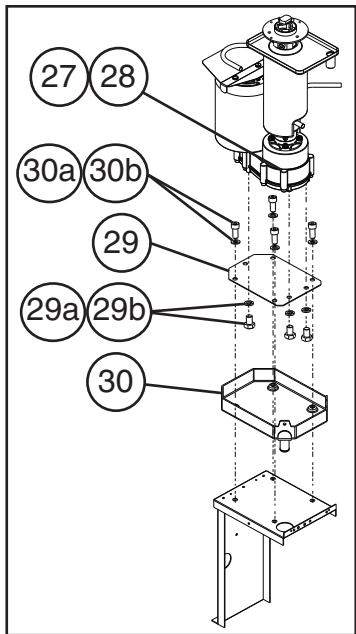

Q-1 and Later

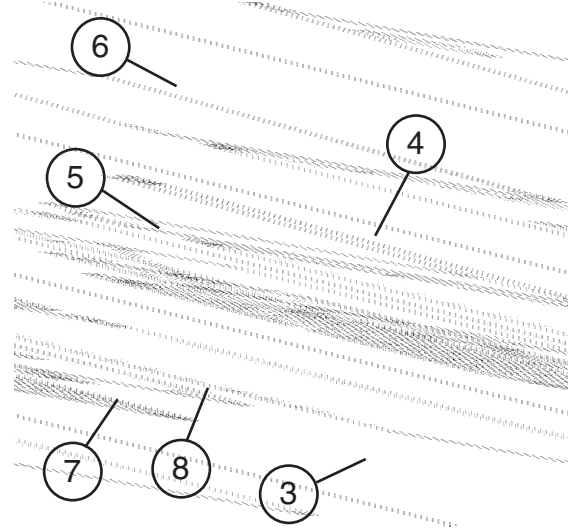

H-0, J-0

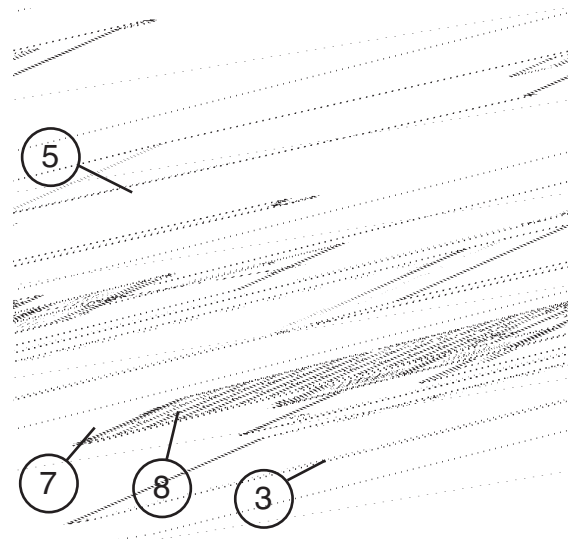

J-1 to Q-0

Title: A. Main Assembly Model: F-500BAF

Index No.	Description	Material or Model Number	Part Number	Required Number								
				H-0 J-0	J-1 M-0	M-1	N-0 Q-0	Q-1 to S-0	S-1 to A-0 (K)	A-0 (L) to C-1 (F)	C-1 (G) to F-0	
1	Top Panel		339872G01	1	1	1	1	-				
			3A3495G01					1	1	1	1	
2	Left Side Panel		227132G01	1	-							
			2A1607G01		1	1	1	1	1	1	1	
3	Right Front Panel-Lower		227133-01	1	-							
	Right Front Panel		2A1620G01		1	1	1	-				
	Front Panel		1A1056-01					1	1	1	1	
4	Right Front Panel-Upper		227134G01	1	-							
5	Left Front Panel-Lower		227135-01	1	-							
	Left Front Panel		1A0472G01		1	1	1	-				
6	Left Front Panel-Upper		339933G01	1	-							
7	Louver		103121-03	1	1	1	1	1	1	1	1	
8	Air Filter		208283G03	1	1	1	1	1	1	1	1	
9	Rear Panel		339857G01	1	1	1	1	1	1	-		
			339857G02								1	-
			3A7428G01									1
10	Junction Box Cover		433410-01	1	1	1	1	1	1	1	1	
11	Spout		227129-01	1	1	-						
			232636G01			1	1	1	1	1	1	1
11a	Thumbscrew		415949G11	3	3	3	3	3	3	3	3	
12	Packing		427151-01	1	1	1	1	1	1	1	1	
13	Spout (B)		227130-01	1	1	-						
			232654-03			1	1	1	1	1	2	2
13a	Thumbscrew		415949G11	4	4	2	2	2	2	2	2	
14	Spout Packing (A)		453663-01	1	1	1	1	1	1	1	1	
15	Spout Packing (B)		453664-01	1	1	-						
			4A2769-01			1	1	1	1	1	1	1
16	Actuator		208795G01	1	1	1	1	1	1	1	1	
17	Hinge		3A0762-01	1	1	1	1	1	1	2	2	
17a	Thumbscrew		415949G08	2	2	2	2	2	2	1	1	
18	Shaft		412337-03	1	1	1	1	1	1	1	1	
19	Snap Pin		715S-0004	1	1	1	1	1	1	1	1	
20	Proximity Switch (Bin Control)		4A2033-01	1	1	1	1	1	1	1	1	
20a	Thumbscrew		415949G08	1	1	1	1	1	1	1	1	
21	Switch Bracket		350284-01			1	1	1	1	-		
22	Lever		3A2365-01			1	1	1	1	-		
23	Microswitch		4A2832-01			1	1	1	1	-		
24	Spring		459287-01			1	1	1	1	-		
25	Evaporator Bracket A		4A2754-01			1	1	1	1	-		
26	Evaporator Bracket B		4A2755-01			1	1	1	1	-		

Title: A. Main Assembly Model: F-500BAF

Index No.	Description	Material or Model Number	Part Number	Required Number								
				H-0 J-0	J-1 M-0	M-1	N-0 Q-0	Q-1 to S-0	S-1 to A-0 (K)	A-0 (L) to C-1 (F)	C-1 (G) to F-0	
27	Socket Hex Head Cap Screw	8x95	7S12-0895	3	3	3	3	3	-			
28	Split Lock Washer		7L22-0800	3	3	3	3	3	-			
29	Gear Motor Bracket		4A4308-01						1	1	1	
29a	Hex Bolt	8x12	7B02-0812						3	3	3	
29b	Split Lock Washer		7L22-0800						3	3	3	
30	Drain Pan		323765G01	1	1	1	1	1	-			
			4A4354G02						1	1	1	
30a	Socket Head Cap Screw		7S12-0820	4	4	4	4	4	4	4	4	
30b	Clinch Nub		4A0633-09	4	4	4	4	4	4	4	4	
31	Edging	L= 900 mm	425931-04	2	2	2	2	2	2	2	2	
32	Sliding Door Assembly (includes items 32 through 35a)		339858A01	1	1	1	1	1	1	1	1	
33	Sliding Door		453697-01	1	1	1	1	1	1	1	1	
34	Sliding Plate		453698-01	1	1	1	1	1	1	1	1	
35	Sliding Collar		453699-01	1	1	1	1	1	1	1	1	
36	Handle		339877G01	1	1	1	1	1	1	1	1	
36a	Hex Head Bolt	4x12, SS	7B02-0412	1	1	1	1	1	1	1	1	
37	Stopper		453670-01	1	1	1	1	1	1	1	1	

B. Refrigeration Circuit

F-500BAF

H-0 to F-0

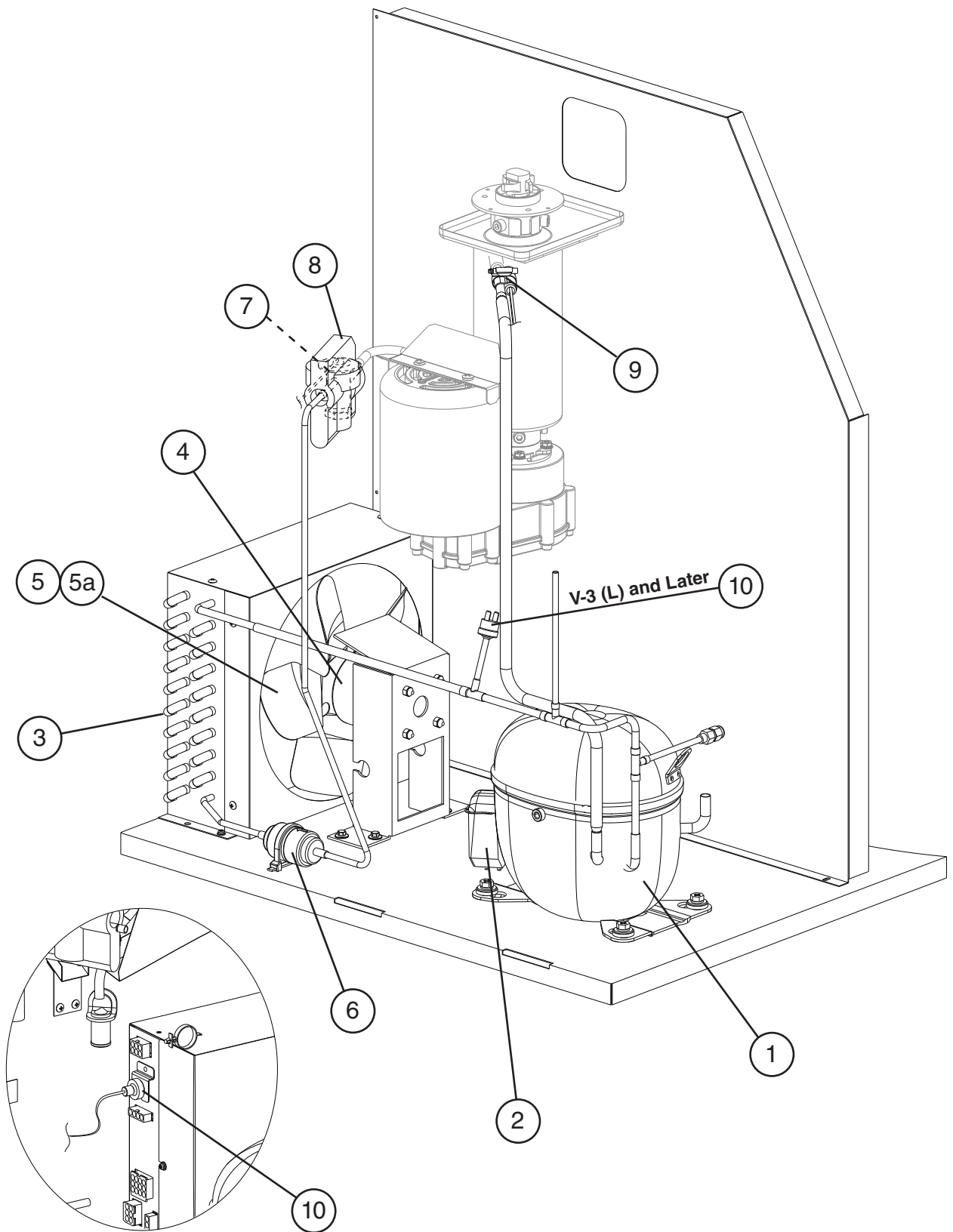

High-Pressure Switch Detail
H-0 to V-3 (K)

Title: B. Refrigeration Circuit Model: F-500BAF

Index No.	Description	Material or Model Number	Part Number	Required Number								
				H-0 to P-0	P-1 to V-0	V-2 to V-3 (K)	V-3 (L) to F-0					
1	Compressor		4A2300-01	1	1	-						
			4A4479-01			1	1					
2	External Protector		4A1805-01	1	1	-						
			4A4481-01			1	1					
3	Condenser		227142-01	1	1	1	1					
4	Fan Motor		440911-01	1	-							
			4A3158-01		1	1	1					
5	Fan Blade		444898-01	1	1	1	1					
5a	Hex Head Bolt w/Washer (LF)	5x12, SS	7B0230512	4	4	4	4					
6	Drier		4A1113-01	1	1	1	1					
7	Thermostatic Expansion Valve		4A1117-01	1	1	1	1					
8	Thermostatic Expansion Valve Cover		4A1168-01	1	1	1	1					
9	Thermostatic Expansion Valve Bulb Holder		3A0107-01	1	1	1	1					
10	High-Pressure Switch		433441-05	1	1	1	-					
			463180-05				1					

C. Icemaking Unit
F-500BAF
H-0 to F-0

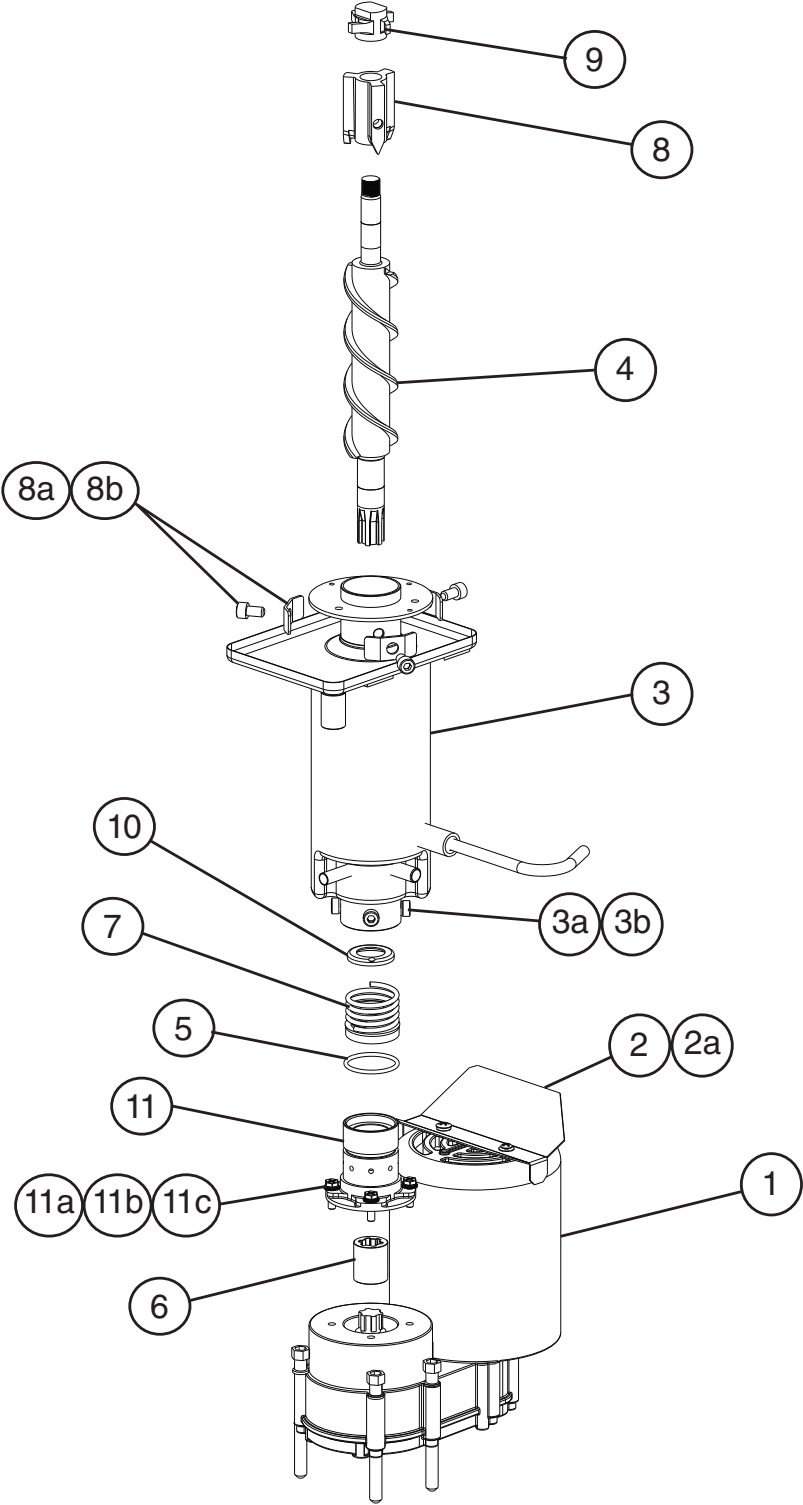

Title: C. Icemaking Unit Model: F-500BAF

Index No.	Description	Material or Model Number	Part Number	Required Number									
				H-0 to K-0	K-1 to S-0	S-1 to T-0	U-0 to F-0						
1	Gear Motor		4A0897-02	1	-								
		HS-2126	4A2193-01		1	-							
			4A4321-01				1	1					
2	Gear Motor Cover		3A4584-01	1	1	1	1						
2a	Truss Head Screw	5x8	7C32-0508	2	2	2	2						
2b	Washer		4A5268-02	2	2	2	2						
3	Evaporator		2A3310G01	1	1	1	1						
3a	Socket Head Cap Screw	6x10, SS	7S12-0610	4	4	4	4						
3b	Split Lock Washer		7L22-0600	4	4	4	4						
4	Auger		341448G01	1	1	1	1						
5	O-Ring		7616-G040	1	1	1	1						
6	Spline Coupling		418316-01	1	1	1	1						
7	Mechanical Seal		432491-01	1	1	1	1						
8	Extruding Head		340077G01	1	1	1	1						
8a	Washer		453791-01	3	3	3	3						
8b	Socket Head Cap Screw	8x14, SS	429121-01	3	3	3	3						
9	Cutter		453790-01	1	1	1	1						
10	Ring		432494-01	1	1	1	1						
11	Housing		206013G03	1	1	1	1						
11a	Bolt/Bolt Assembly	6x20, SS	7B02-0620	4	4	4	-						
		6x20, SS	4A1989-01				4						
11b	Washer		7W22-0600	4	4	4	-						
11c	Spring Washer		7L22-0600	4	4	4	-						

D. Water Circuit
F-500BAF
H-0 to F-0

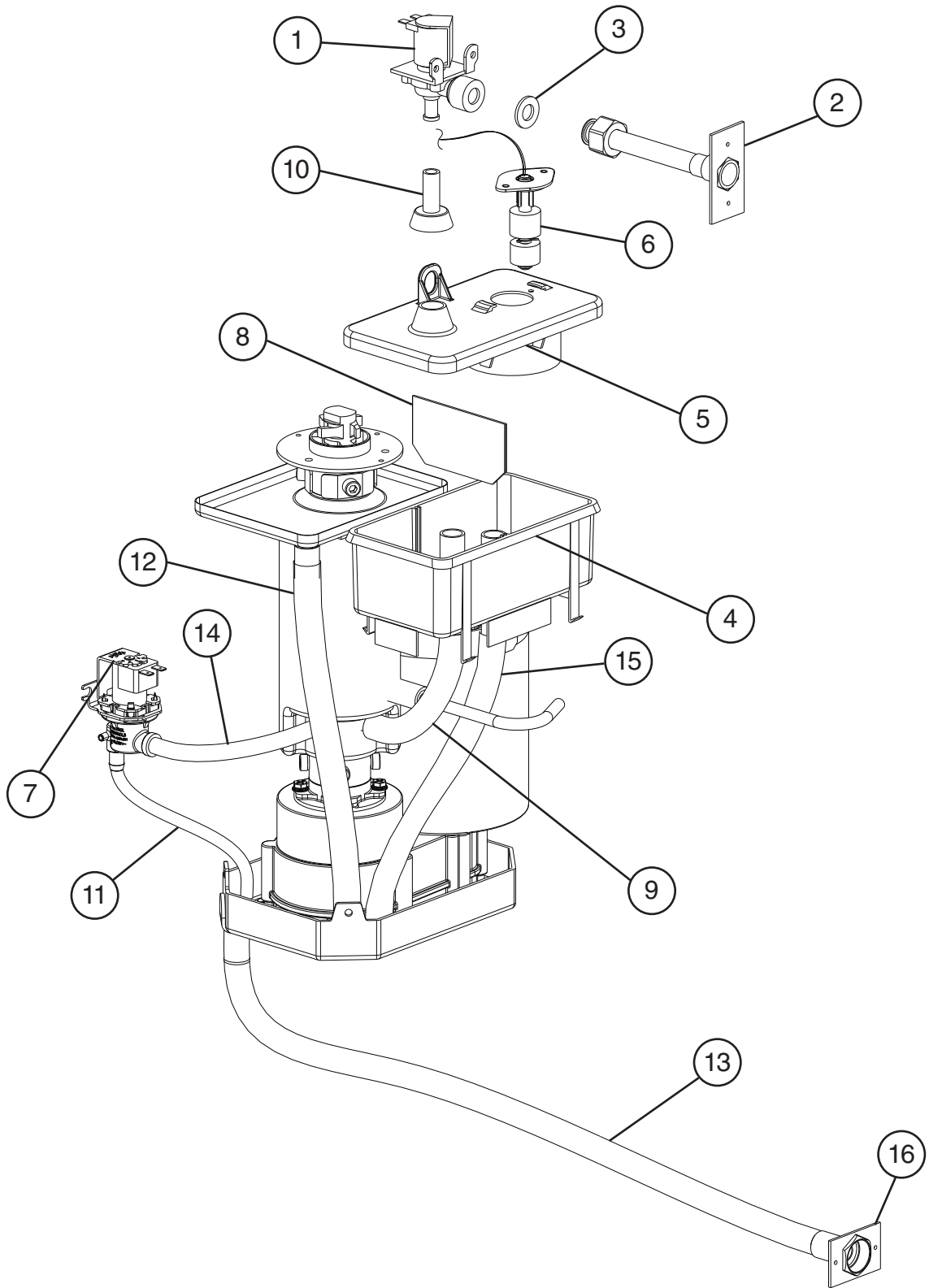

Title: D. Water Circuit Model: F-500BAF

Index No.	Description	Material or Model Number	Part Number	Required Number									
				H-0 J-0	J-1	K-0 to N-0	P-0 to S-0	S-1 to F-0					
1	Inlet Water Valve		4A0865-01	1	1	1	1	-					
			4A5309-01					1					
2	Water Supply Pipe		4A0891G02	1	1	1	1	1					
3	Washer		4A0867-01	1	1	1	1	1					
4	Reservoir		2A0753-01	1	1	1	1	1					
5	Reservoir Cover		214810-01	1	1	1	1	1					
6	Float Switch		435490-01	1	1	1	1	1					
7	Drain Water Valve		4A0866-01	1	1	-							
			4A2077-01			1	-						
			4A2772-01				1	1					
8	Reservoir Separator		4A1255-01	1	1	1	1	1					
9	Reservoir Hose		4A1165-02	1	1	1	1	1					
10	Reservoir Inlet		4A0869-01	1	1	1	1	1					
11	Vinyl Hose	L=200 mm	7730-0912	1	1	-							
		L=190 mm	7716-0913			1	1	1					
12	Vinyl Hose	L=360 mm	7725-1923	1	1	1	1	1					
13	Vinyl Hose	L=715 mm	7725-1923	1	1	1	1	1					
14	Silicone Hose	L=160 mm	7730-0912	1	1	-							
		L=160 mm	7730I3896			1	1	1					
15	Silicone Hose	L=290 mm	7730-1822	1	1	1	1	1					
16	Drain Fitting		4A0776G01	1	1	1	1	1					
Hose Clamp													
	Hose Clamp		4A2017-06	1	1	1	1	1					
	Hose Clamp		421642-04	4	-								
			4A2017-04		4	-							
			4A2017-08			4	4	4					
	Hose Clamp		4A2017-05	1	1	1	1	1					
	Hose Clamp		4A2017-01	3	3	3	6	2					
	Hose Clamp		4A2017-02	1	1	1	1	2					

E. Control Box Assembly
F-500BAF
 H-0 to F-0

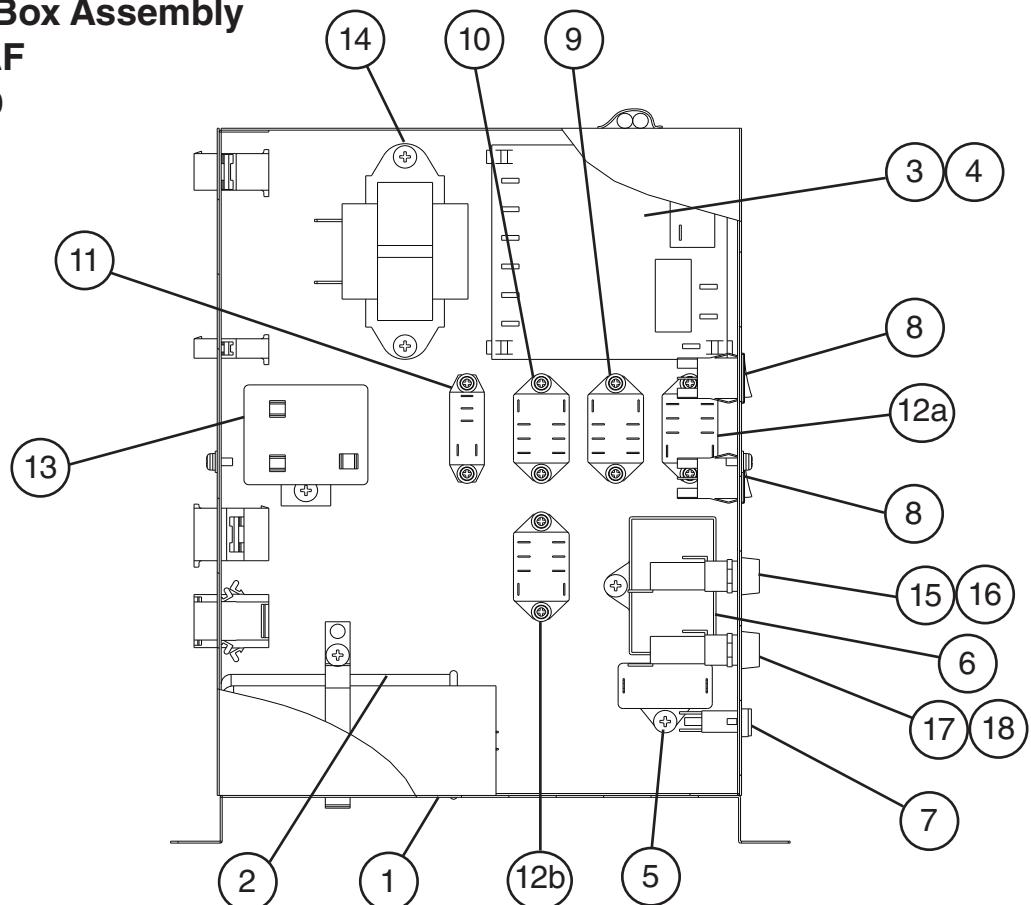

H-0 to A-0 (B)

A-0 (C) to E-0

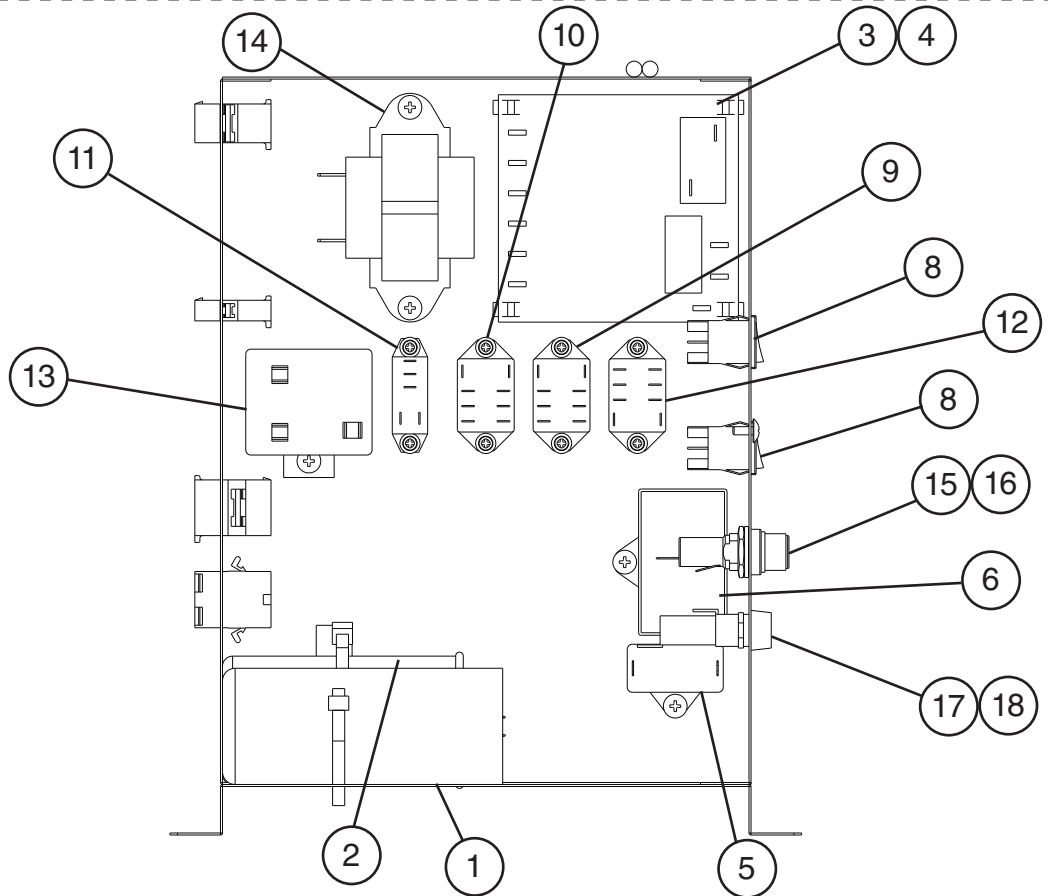

Title: E. Control Box Assembly Model: F-500BAF

Index No.	Description	Material or Model Number	Part Number	Required Number									
				H-0 to K-0	K-1 L-0	M-0 to S-0	S-1 to V-0	V-2 to A-0 (B)	A-0 (C) to B-0	C-1 to F-0			
1	Starting Capacitor	243-292MFD, 115VAC	3A0076-10	1	1	1	1	-					
		243-292MFD, 165VAC	3A0076-20					1	1	1			
2	Run Capacitor	15MFD, 370VAC	439943-04	1	1	-							
			3A2005-08			1	1	-					
		35MFD, 440VAC	3A2005-12					1	1	1			
3	Timer Board		437305-01	1	1	1	1	1	1	-			
	"LA" Control Board		4A5591-01								1		
4	Control Board Support		4A0336-03	4	4	4	4	4	4	4			
5	Fan Motor Capacitor	5MFD, 250VAC	443192-02	1	1	1	1	1	1	1			
6	Gear Motor Capacitor	20MFD, 350VAC	4A0894-01	1	1	1	-						
			4A4319-01				1	1	1	1			
7	Gear Motor Protector		440972-02	1	-								
8	Rocker Switch		4A0558-01	2	2	2	2	2	2	2			
9	Gear Motor Protect Relay	120VAC	406132-07	1	1	1	1	1	1	1			
10	Circuit Protect Relay	240VAC	418271-05	1	1	1	1	1	1	1			
11	Flush/Drain Valve Control Relay	24VAC	430173-03	1	1	1	1	1	1	1			
12	Water Control Relay (12a) Safety (12b)	24VAC	406132-06	1	1	1	2	2	1	1			
13	Start Relay		4A1107-11	1	1	1	1	1	1	1			
14	Control Transformer		4A0557-01	1	1	1	1	1	1	1			
15	Fuse Holder		4A0892-01	1	1	1	1	-					
			4A5443-01					1	1	1			
16	Fuse (Control)	AGC-1A, 250VAC	4A0893-01	1	1	1	1	1	1	1			
17	Fuse Holder		4A3449-02		1	1	1	1	1	1			
18	Fuse (Gear Motor)	GMD-1.5A, 250VAC	4A0893-04		3	3	-						
		GMD-2.0A, 250VAC	4A0893-05				3	3	3	3			

F. Accessories & Labels

F-500BAF

H-0 to F-0

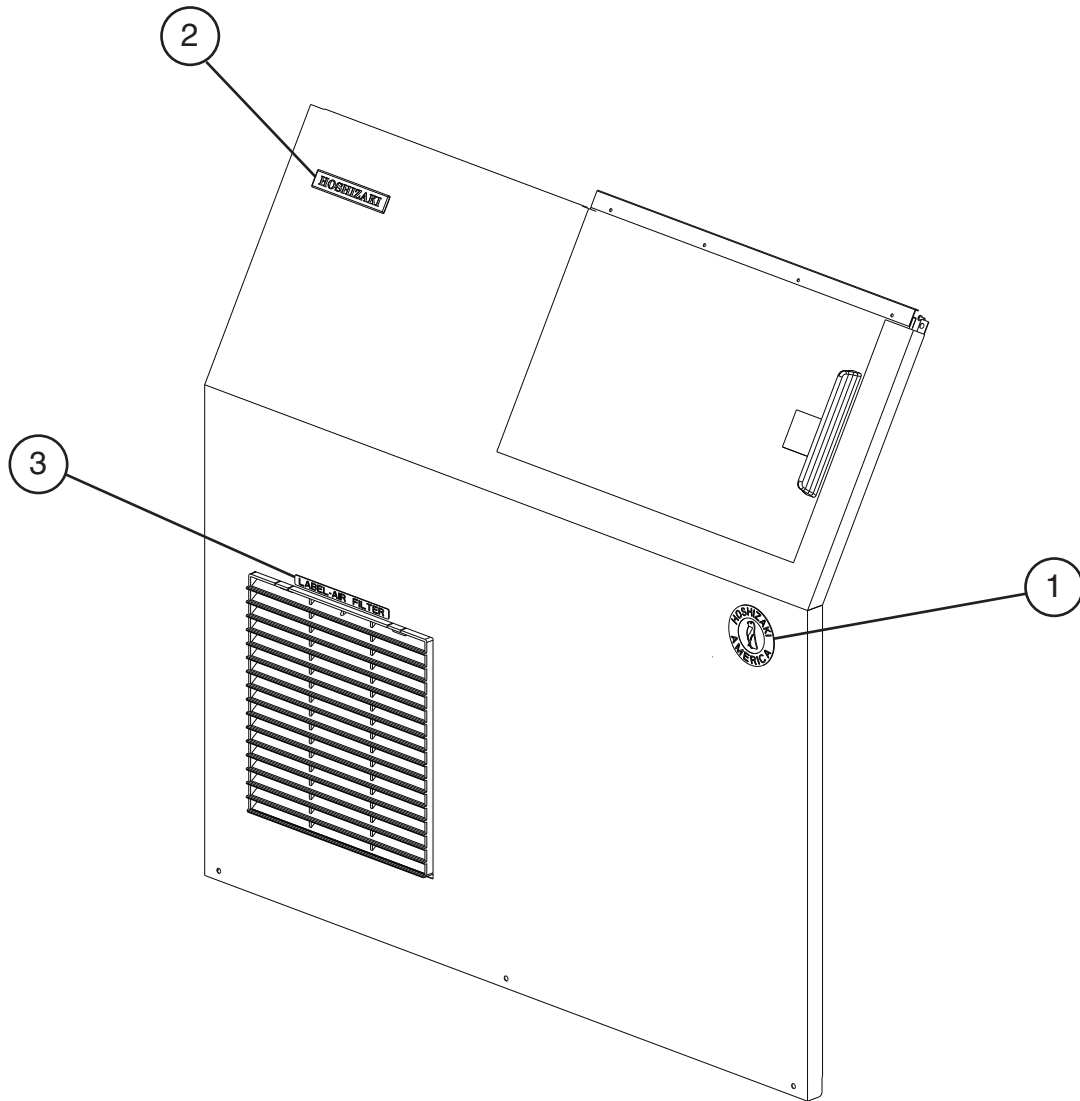

Title: F. Accessories & Labels		Model: F-500BAF		Required Number							
Index No.	Description	Material or Model Number	Part Number	H-0 to Q-0	Q-1 to F-0						
				1	Penguin-HA-L Label		4A0526-02	1	1		
2	Emblem		4A0560-01	1	1						
3	Air Filter Label		426177-01	1	1						
4	Leg - Box of 4, Stainless Steel (Option)		4A2113-01	1	-						
	Leg - Box of 4, Painted (Option)		444138-01	1	-						
	Legs		4A2525-01		4						
5	Scoop		4A2246-01	1	1						