

Hoshizaki America, Inc.

Modular Flaker

Models

F-2000MWH

F-2000MRH(3)(-C)

F-2000MLH



“A Superior Degree
of Reliability”

www.hoshizaki.com

PARTS LIST



Number: 71339
Issued: 2-3-2012

CONTENTS

Auxiliary Codes.....	3
Note About Ordering Parts	4
A. Ice Flaker Assembly	5
B. Ice Making Unit.....	8
C. Refrigeration Circuit.....	10
F-2000MWH	10
F-2000MRH(3)(-C)	12
F-2000MLH	14
D. Water Circuit	16
E. Control Box Assembly.....	18
F. Chute Assembly	21
G. Accessories, Labels, & Packaging	23

Auxiliary Codes

F-2000MWH

L-0 July 2001
M-0 March 2002
M-1 August 2002
N-0 December 2002
P-0 December 2003
P-1 May 2004
Q-0 January 2005
R-0 December 2005
S-0 January 2007
T-0 February 2008
T-1 June 2008
U-0 January 2009
V-0 January 2010
V-1 June 2010
V-2 September 2010
A-0 January 2011
A-1 October 2011
B-0 January 2012
B-1 March 2012

F-2000MRH

L-0 May 2001
M-0 April 2002
N-0 January 2003
P-0 January 2004
P-1 August 2004
Q-0 March 2005
R-0 December 2005
S-0 January 2007
T-0 January 2008
T-1 June 2008
U-0 January 2009
V-0 January 2010
V-2 August 2010
V-3 November 2010
A-0 January 2011
A-1 November 2011
B-0 January 2012
B-1 March 2012

F-2000MRH3

L-0 April 2001
M-0 January 2002
N-0 December 2002
P-0 December 2003
P-1 August 2004
Q-0 May 2005
R-0 January 2006
S-0 January 2007
T-0 January 2008
T-1 June 2008
U-0 January 2009
V-0 January 2010
V-1 May 2010
V-2 August 2010
V-3 November 2010
A-0 January 2011
A-1 October 2011
B-0 January 2012
B-1 March 2012

F-2000MRH-C

T-0 April 2008
T-1 June 2008
U-0 January 2009
V-0 January 2010
V-1 June 2010
V-2 August 2010
V-3 October 2010
A-0 January 2011
A-1 October 2011
B-0 January 2012
B-1 March 2012

F-2000MLH	M-0	February 2002
	M-1	June 2002
	N-0	January 2003
	P-0	December 2003
	P-1	May 2004
	Q-0	December 2004
	R-0	December 2005
	S-0	January 2007
	T-0	January 2008
	U-0	February 2009
	V-0	February 2010
	V-1	May 2010
	V-2	August 2010
	A-0	January 2011
	A-1	November 2011
	B-0	January 2012
B-1	March 2012	

Auxiliary Code Breakdown

The auxiliary code is the first two characters in the serial number. The first character indicates the year. Years progress or regress in alphabetical order. The series runs from "A" through "V" and the letters "I" and "O" are skipped. The second character indicates significant part changes within a year. Base is "0" and this number advances for each change. In cases where there is a letter in parentheses, this designates the month. This is the last character in the serial number. The series runs from "(A)" through "(M)" and the letter "(I)" is skipped. This designation is only included when identifying a parts change within an auxiliary code.

Note About Ordering Parts

Most assemblies cannot be ordered as complete units; parts in the assemblies generally must be ordered separately.

A. Ice Flaker Assembly

F-2000MWH, F-2000MRH(3)(-C), F-2000MLH

L-0 to B-1

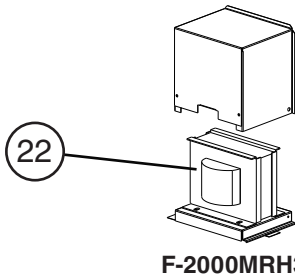
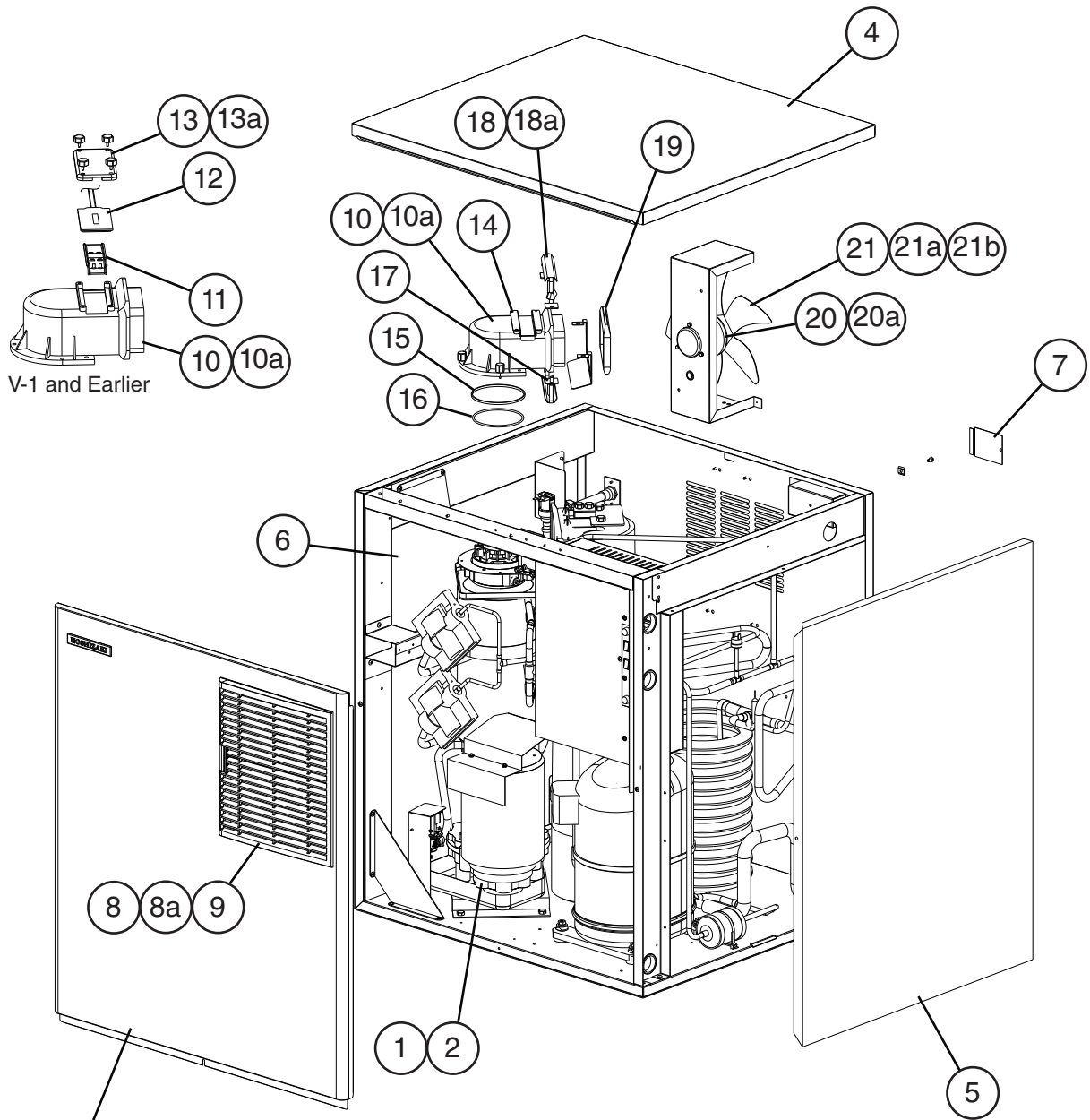

Title: **A. Ice Flaker Assembly** Model: **F-2000MWH, F-2000MRH(3)(-C), F-2000MLH**

Index No.	Description	Material or Model Number	Part Number	Required Number									
				L-0 to T-0	T-1 U-0	V-0	V-1	V-2 to B-0	B-1				
Ice Flaker Assembly Order Assembly Parts Individually	F-2000MWH		1A0557A03	1	-								
			1A1568A01		1	1	-						
			1A1568A02				1	-					
			1A1568A03					1	-				
			1A2225A01							1			
	F-2000MRH		1A0558A01	1	-								
			1A1577A01		1	1	-						
			1A1577A04				1	-					
			1A1577A07					1	-				
			1A2227A01							1			
	F-2000MRH3		1A0559A01	1	-								
			1A1577A03		1	1	-						
			1A1577A06				1	-					
			1A1577A09					1	-				
			1A2227A03							1			
	F-2000MRH-C		1A1577A02	1	1	1	-						
			1A1577A05				1	-					
			1A1577A08					1	-				
			1A2227A02							1			
	F-2000MLH		1A0560A01	1	-								
		1A1574A01		1	1	-							
		1A1574A02				1	-						
		1A1574A03					1	-					
		1A2226A01							1				
1	Socket Head Cap Screw	10x1.5, SS	420600-02	3	3	3	3	3	3				
2	Spring Washer	M10, SS	7L22-1000	3	3	3	3	3	3				
3	Front Panel		2A2075-01	1	1	1	1	1	1				
4	Top Panel		2A2074-01	1	1	1	1	1	1				
5	Right Side Panel		2A2077G01	1	1	1	1	1	1				
6	Left Side Panel		2A2076G01	1	1	1	1	1	1				
7	Junction Box Cover	F-2000MWH F-2000MLH	433410-01	1	1	1	1	1	1	1			
		F-2000MRH F-2000MRH3 F-2000MRH-C	433410-01	2	2	2	2	2	2	2			
8	Louwer		1A0547-01	1	1	1	1	1	1				
8a	Push Retainer		4A2414-01	3	3	3	3	3	3				
9	Air Filter		2A2062G01	1	1	1	1	1	1				
10	Spout		105378G01	1	1	1	1	1	1				
10a	Thumbscrew		415949G11	3	3	3	3	3	3				
11	Actuator		327038-01	1	1	1	1	-					
12	Belt Switch		440973-01	1	1	1	1	-					
13	Switch Cover		327037-01	1	1	1	1	-					
13a	Thumbscrew		415949G04	4	4	4	4	-					
14	Spout Cover		4A5174-01					1	1				
15	Ring		431736-01	1	1	1	1	1	1				
16	"O" Ring		7616-G095	1	1	-							
			4A4755-05			1	1	1	1				

Title: A. Ice Flaker Assembly Model: F-2000MWH, F-2000MRH(3)(-C), F-2000MLH												
Index No.	Description	Material or Model Number	Part Number	Required Number								
				L-0 to T-0	T-1 U-0	V-0	V-1	V-2 to B-0	B-1			
17	Lower Spout Strap		327041G02	1	1	1	1	1	-			
			3A6913G01						1			
18	Upper Spout Strap		327042-04	1	1	1	1	1	-			
			3A6912-02						1			
18a	Wing Nut	M6, SS	7E12-0600	2	2	2	2	2	2			
19	Packing		327040-01	1	1	1	1	1	1			
20	Fan Motor		440917-01	1	1	1	1	1	1			
20a	Screw		436863-01	3	3	3	3	3	3			
21	Fan Blade		434959-01	1	1	1	1	1	1			
21a	Hex Nut		4A1345-01	1	1	1	1	1	1			
21b	Washer		435983-01	1	1	1	1	1	1			
22	Main Transformer	F-2000MRH3	2U0128-01	1	1	1	1	1	1			

B. Ice Making Unit

F-2000MWH, F-2000MRH(3)(-C), F-2000MLH

L-0 to B-1

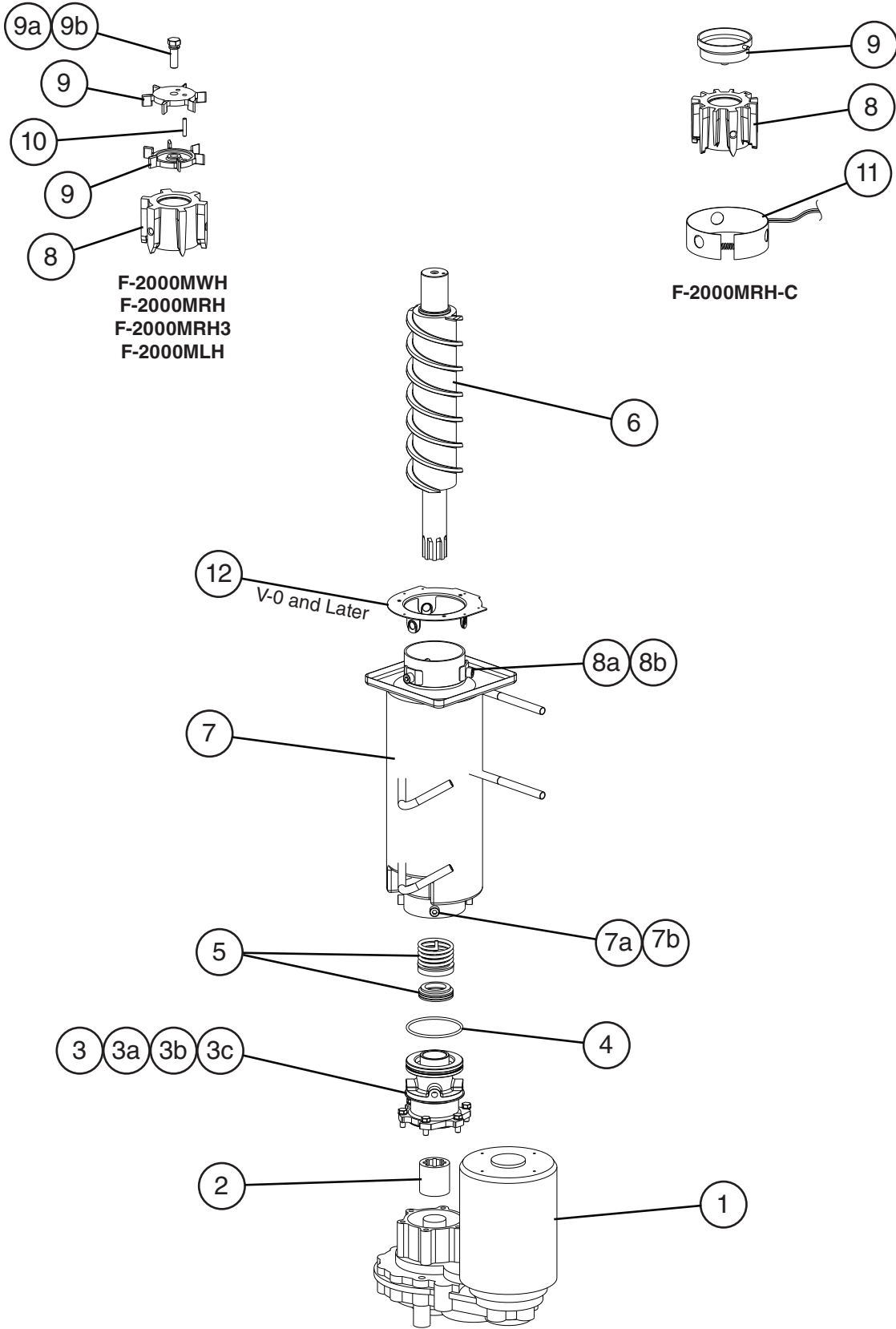

Title: B. Ice Making Unit Model: F-2000MWH, F-2000MRH(3)-C, F-2000MLH											
Index No.	Description	Material or Model Number	Part Number	Required Number							
				L-0 to U-1	V-0 to B-1						
	Ice Making Unit Order Assembly Parts Individually	F-2000MWH F-2000MRH F-2000MRH3 F-2000MLH	3A3061A01	1	1						
		F-2000MRH-C	3A3061A02	1	1						
1	Gear Motor (for mounting hardware see section "A" items 1 and 2)		2U0129-01	1	1						
2	Coupling		420372-01	1	1						
3	Housing		206509G02	1	1						
3a	Hex Head Bolt	8x25, SS	7B02-0825	6	6						
3b	Washer	M8, SS	7W22-0800	6	6						
3c	Split Lock Washer	M8, SS	7L22-0800	6	6						
4	"O" Ring		7616-G090	1	-						
			4A4755-04		1						
5	Mechanical Seal		432493-01	1	1						
6	Auger		120864G02	1	1						
7	Evaporator		228196G01	1	-						
			228196G06		1						
7a	Socket Head Cap Screw	10x20, SS	7S12-1020	4	4						
7b	Split Lock Washer	M10, SS	7L22-1000	4	4						
8	Extruding Head	F-2000MWH F-2000MRH F-2000MRH3 F-2000MLH	216407G01	1	1						
		F-2000MRH-C	2A1594G01	1	1						
8a	Seal Bolt	M10, SS	474757G01	3	3						
8b	Washer		425277-01	3	-						
9	Cutter	F-2000MWH F-2000MRH F-2000MRH3 F-2000MLH	327026-01	2	2						
		F-2000MRH-C	315736G01	1	1						
9a	Hex Head Bolt	F-2000MWH F-2000MRH F-2000MRH3 F-2000MLH 10x35, SS	7B02-1035	1	1						
9b	Split Lock Washer	F-2000MWH F-2000MRH F-2000MRH3 F-2000MLH M10, SS	7L22-1000	1	1						
10	Dowel Pin	F-2000MWH F-2000MRH F-2000MRH3 F-2000MLH	713S-0526	1	1						
11	Heater	F-2000MRH-C	4A4335-01	1	1						
12	Flange		352714-01		1						

C. Refrigeration Circuit

F-2000MWH

L-0 to B-1

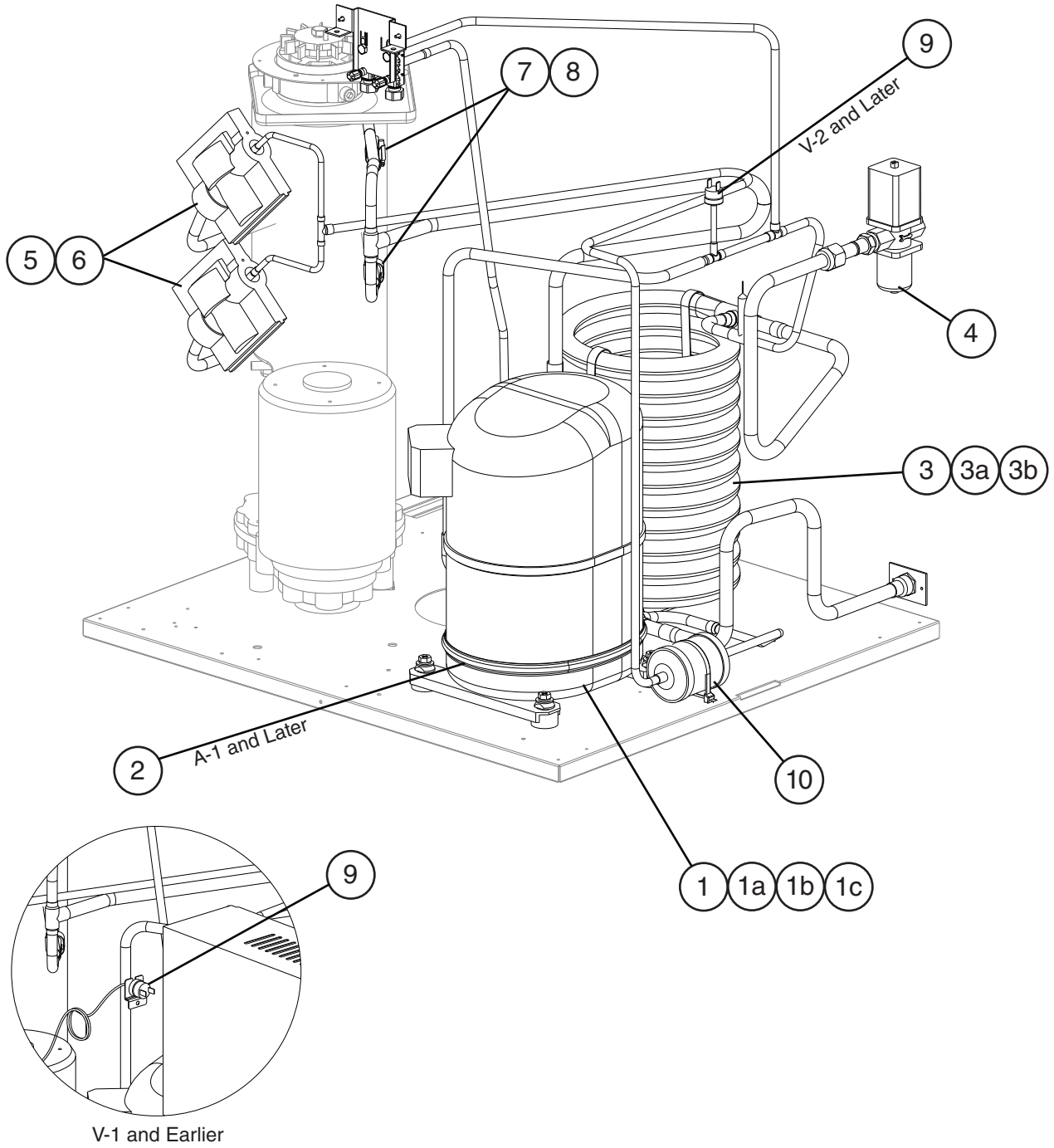

Title: **C. Refrigeration Circuit** Model: **F-2000MWH**

Index No.	Description	Material or Model Number	Part Number	Required Number									
				L-0	M-0 to R-0	S-0 to V-1	V-2 A-0	A-1 to B-1					
Refrigeration Circuit Order Assembly Parts Individually			108794A01	1	-								
			1A0673A01		1	-							
			1A1216A01			1	-						
			1A2093A01				1	1					
1	Compressor (A-1 and later utilize external crankcase heater - item 2)		4A1420-02	1	1	1	1	-					
			4A4890-01					1					
1a	Grommet		434922-01	4	4	4	4	4					
1b	Spacer		434921-01	4	4	4	4	4					
1c	Bolt		437889-01	4	4	4	4	4					
2	Crankcase Heater		434186-01					1					
3	Condenser	HS-0164	2A0931-02	1	-								
			2A2359G05		1	1	1	1					
3a	Hex Head Bolt w/Washer	5x16, SS	7B0230516	3	2	2	2	2					
3b	Washer		7W22-0600	3	2	2	2	2					
4	Water Regulating Valve		4A1417-01	1	1	1	1	1					
5	Thermostatic Expansion Valve		4A1117-01	2	2	2	2	2					
6	Thermostatic Expansion Valve Cover		4A1168-01	2	2	2	2	2					
7	Thermostatic Expansion Valve Bulb Holder		3A0112-01	2	2	2	2	2					
8	Clamp		443461-01	2	2	2	2	2					
9	High-Pressure Switch		433441-05	1	1	1	-						
			463180-05				1	1					
10	Drier		4A1338-01	1	1	1	1	1					

C. Refrigeration Circuit
F-2000MRH(3)(-C)
 L-0 to B-1

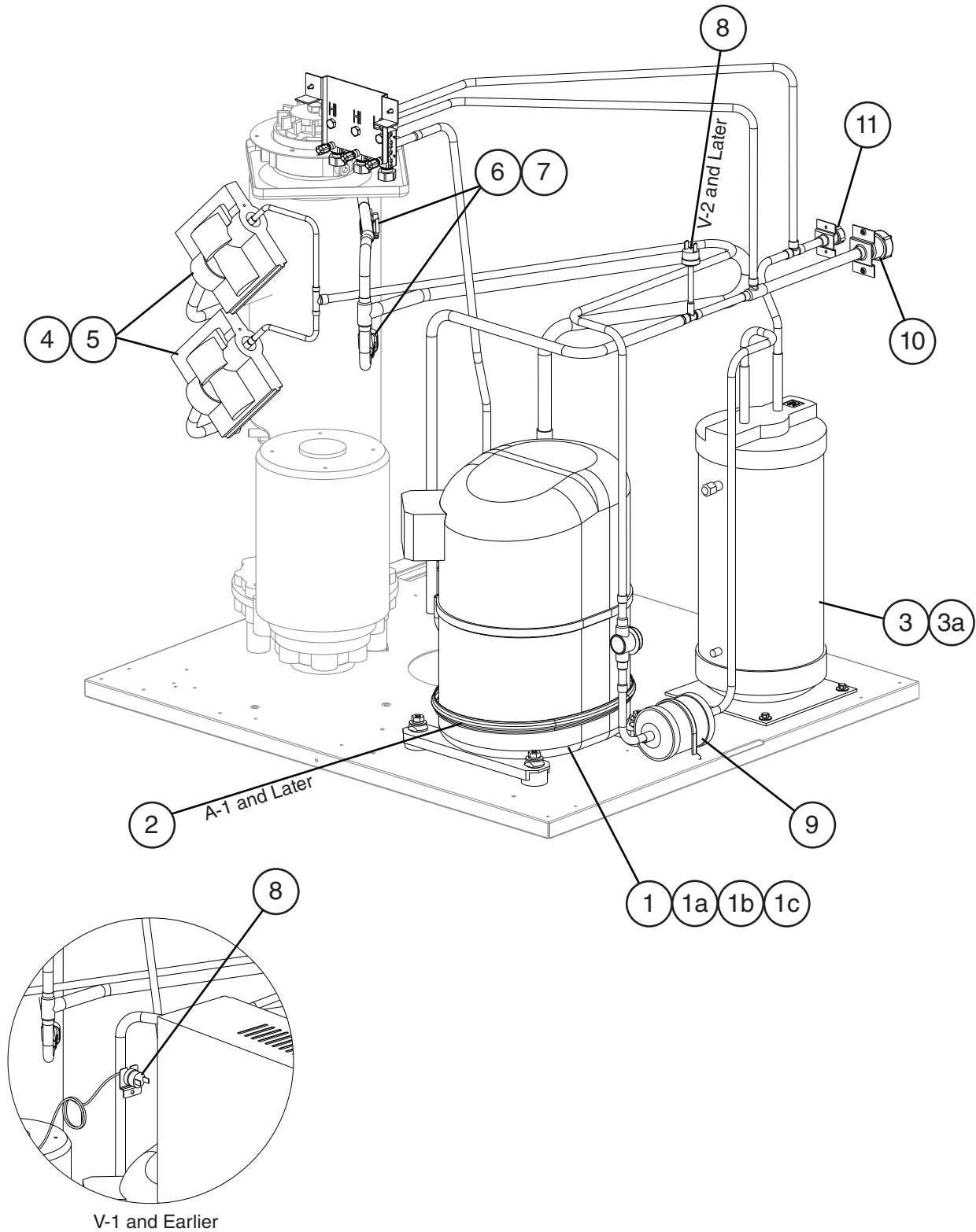

Title: C. Refrigeration Circuit Model: F-2000MRH(3)(-C)												
Index No.	Description	Material or Model Number	Part Number	Required Number								
				L-0 to R-0	S-0 T-0	T-1 to V-1	V-2 to A-0	A-1 to B-1				
Refrigeration Circuit Order Assembly Parts Individually		F-2000MRH F-2000MRH-C	108791A01	1	-							
			1A1217A01		1	-						
			1A1576A01			1	-					
			1A2094A01				1	1				
		F-2000MRH3	108791A02	1	-							
			1A1217A02		1	-						
			1A1576A02			1	-					
			1A2094A02				1	1				
1	Compressor (A-1 and later utilize external crankcase heater - item 2)	F-2000MRH F-2000MRH-C	4A1420-02	1	1	1	1	-				
			4A4890-01					1				
		F-2000MRH3	4A1419-02	1	1	1	1	-				
			4A4891-01					1				
1a	Grommet		434922-01	4	4	4	4	4				
1b	Spacer		434921-01	4	4	4	4	4				
1c	Bolt		437889-01	4	4	4	4	4				
2	Crankcase Heater		434186-01					1				
3	Receiver		438209-01	1	1	1	1	1				
3a	Hex Head Bolt w/Washer	5x10, SS	7B0230510	3	3	3	3	3				
4	Thermostatic Expansion Valve		4A1117-01	2	2	2	2	2				
5	Thermostatic Expansion Valve Cover		4A1168-01	2	2	2	2	2				
6	Thermostatic Expansion Valve Bulb Holder		3A0112-01	2	2	2	2	2				
7	Clamp		443461-01	2	2	2	2	2				
8	High-Pressure Switch		433441-05	1	1	1	-					
			463180-05				1	1				
9	Drier		4A1338-01	1	1	1	1	1				
10	Discharge Line Coupling		434072-01	1	1	1	1	1				
11	Liquid Line Coupling		426554-01	1	1	1	1	1				

C. Refrigeration Circuit
F-2000MLH
M-0 to B-1

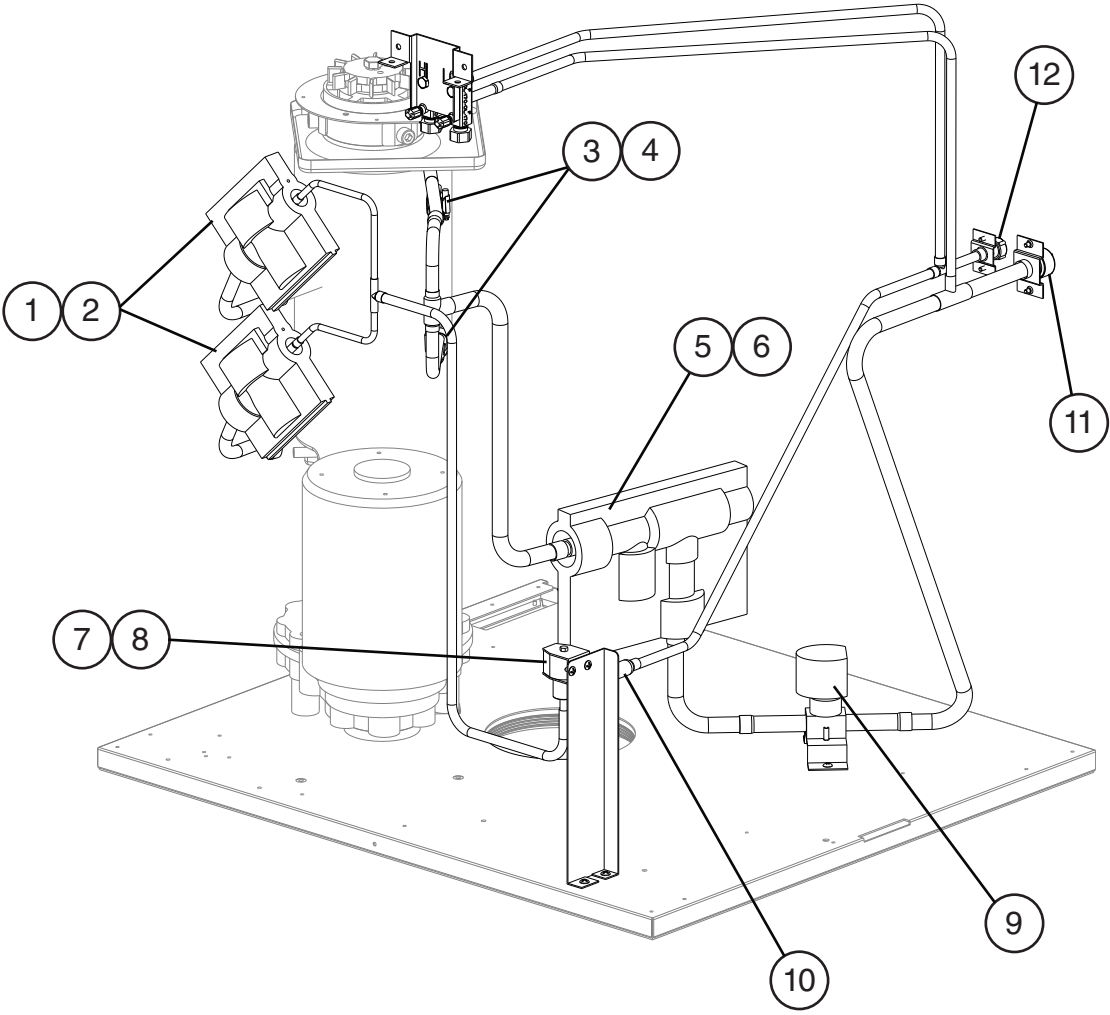

Title: C. Refrigeration Circuit Model: F-2000MLH												
Index No.	Description	Material or Model Number	Part Number	Required Number								
				M-0 to Q-0 (K)	Q-0 (L) to R-0	S-0 to B-1						
Refrigeration Circuit Order Assembly Parts Individually			108798A01	1	1	-						
			1A1219A01			1						
1	Thermostatic Expansion Valve		4A1117-01	2	2	2						
2	Thermostatic Expansion Valve Cover		4A1168-01	2	2	2						
3	Thermostatic Expansion Valve Bulb Holder		3A0112-01	2	2	2						
4	Clamp		443461-01	2	2	2						
5	EPR (Evaporator Pressure Regulator) Valve		446872-02	1	1	1						
6	EPR (Evaporator Pressure Regulator) Valve Cover		340434-01	1	1	1						
7	Liquid Line Valve Body		440352-01	1	-							
			4A3276-01		1	1						
8	Valve Coil		440353-01	1	-							
			4A3277-01		1	1						
9	Suction Line Valve		446873-01	1	1	1						
10	Strainer		4A1385-01	1	1	1						
11	Suction Line Coupling		448569-01	1	1	1						
12	Liquid Line Coupling		426554-01	1	1	1						

D. Water Circuit
F-2000MWH, F-2000MRH(3)(-C), F-2000MLH
L-0 to B-1

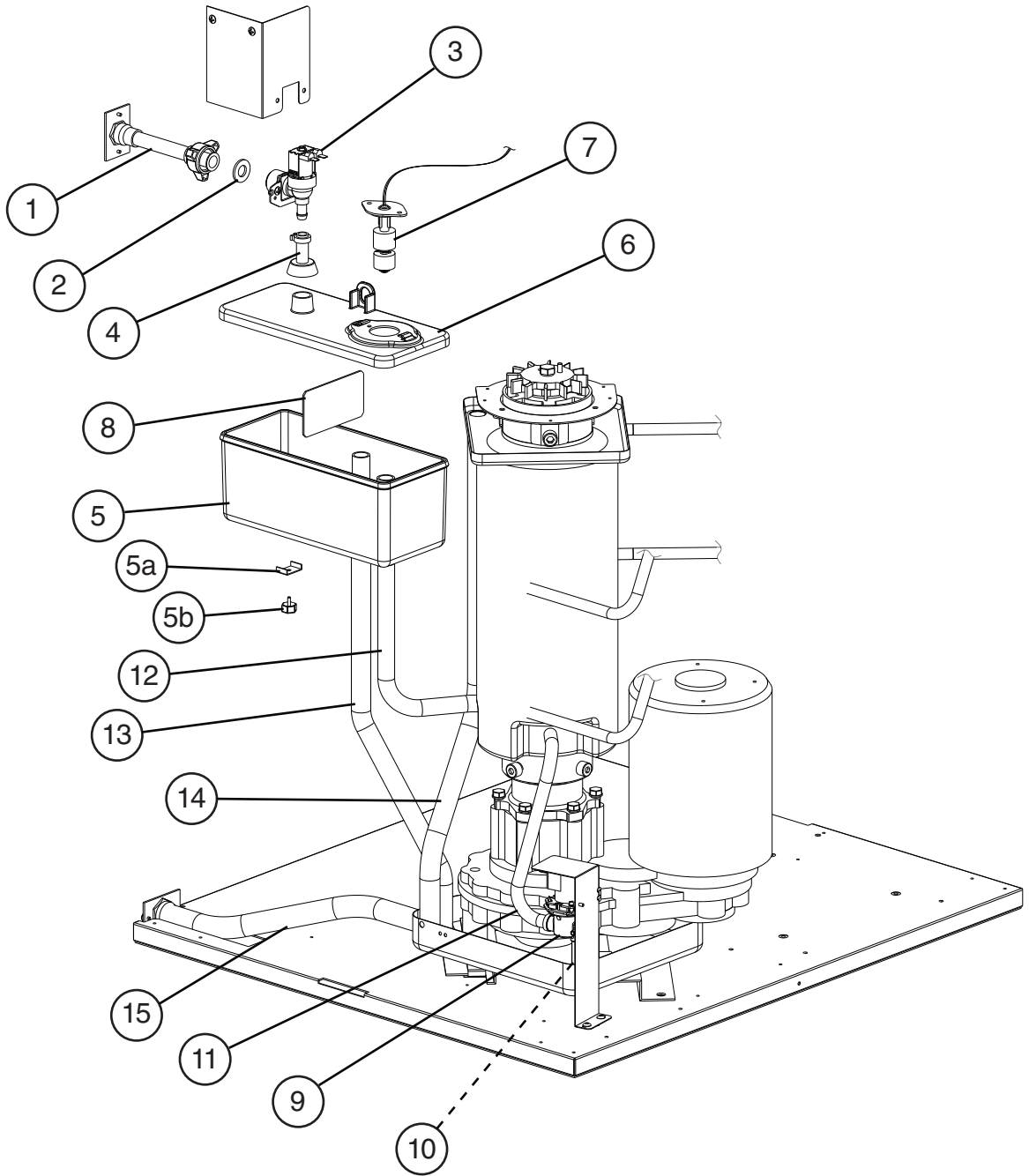

Title: **D. Water Circuit** Model: **F-2000MWH, F-2000MRH(3)(-C), F-2000MLH**

Index No.	Description	Material or Model Number	Part Number	Required Number									
				L-0	M-0 to P-0	P-1 to B-0	B-1						
Water Circuit Order Assembly Parts Individually			HS-0115	108790A01	1	-							
				1A0734A01		1	1	-					
				1A0734A02				1					
1	Water Supply Pipe		4A0891G01	1	1	1	-						
				4A0891G02				1					
2	Washer		4A0867-01	1	1	1	1						
3	Inlet Water Valve		4A0865-01	1	1	1	-						
				4A5309-01				1					
4	Reservoir Inlet		4A0869-01	1	1	1	1						
5	Reservoir		208125-01	1	1	1	1						
5a	Collar		423416-03	1	1	1	1						
5b	Thumbscrew		415949G04	1	1	1	1						
6	Reservoir Cover		208126-01	1	1	1	1						
7	Float Switch		435490-01	1	1	1	1						
8	Reservoir Separator		423538-02	1	1	1	1						
9	Drain Valve		4A2077-01	1	-								
				4A2772-01		1	1	1					
10	Hose	L=45	7716-0913	1	1	1	1						
11	Vinyl Hose	L=370	7725-0912	1	-								
				7730I3896		1	1	1					
12	Silicone Hose	L=260	7730-1519	1	1	1	1						
13	Silicone Hose	L=520	7730-1721	1	1	-							
				7730-1822			1	-					
				7725-1923				1					
14	Vinyl Hose	L=650	7725-1923	1	1	1	1						
15	Vinyl Hose	L=320	7716-2025	1	1	1	1						
Hose Clamps													
	Hose Clamp	13.5-15.1mm	4A2017-08	4	4	4	4						
	Hose Clamp	17.1-20.6mm	4A2017-05	2	2	2	2						
	Hose Clamp	21.2-26.2mm	4A2017-01	2	2	2	-						
	Hose Clamp	26.2-30.2mm	4A2017-02	1	1	1	-						

E. Control Box Assembly
F-2000MWH, F-2000MRH(3)(-C), F-2000MLH
 L-0 to B-1

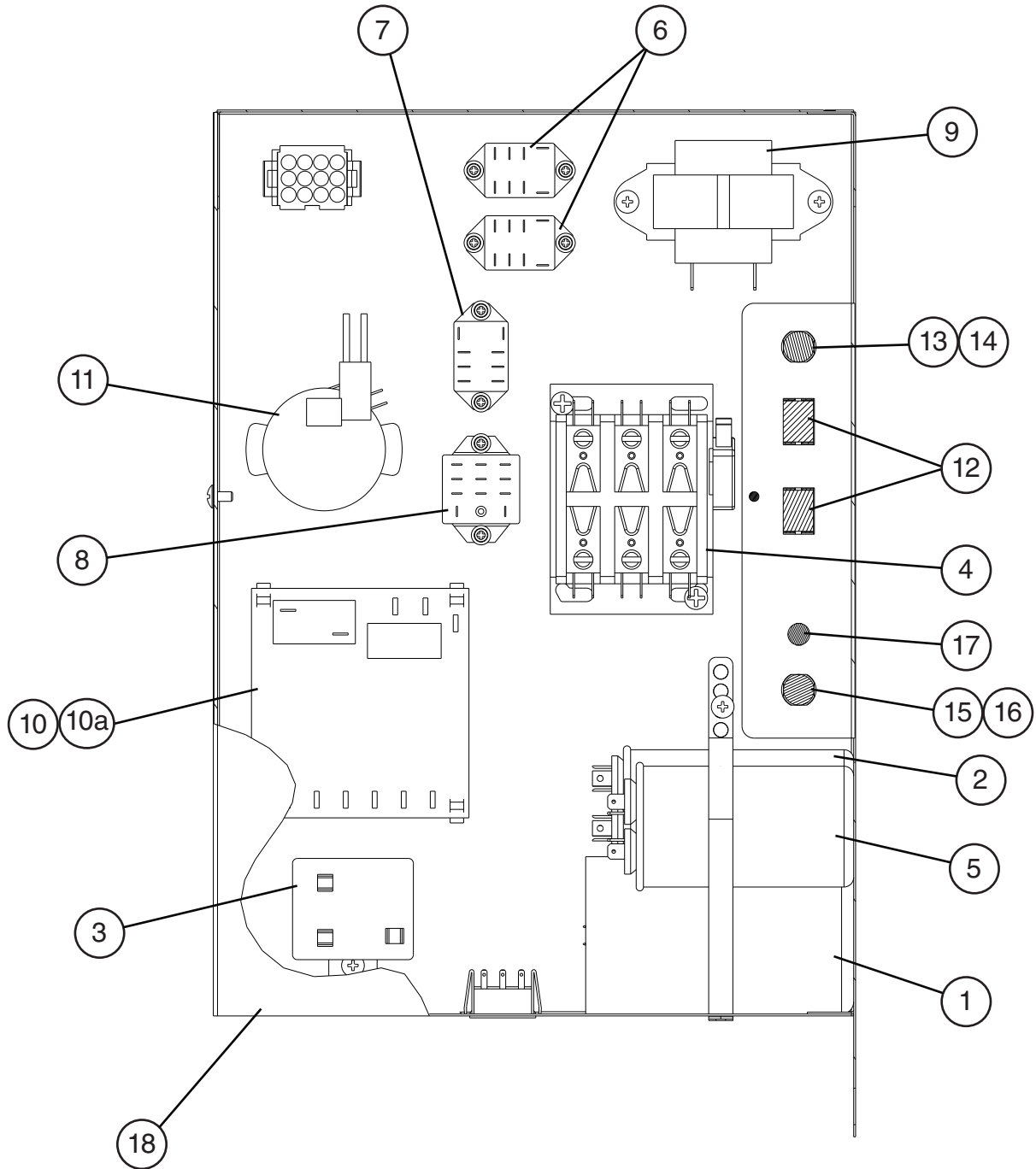

Title: E. Control Box Assembly Model: F-2000MWH, F-2000MRH(3)(-C), F-2000MLH														
Index No.	Description	Material or Model Number	Part Number	Required Number										
				L-0	M-0 to Q-0 (E)	Q-0 (F) to T-0	T-1 to V-1	V-2 to V-3	A-0 to B-1					
Control Box Assembly Order Assembly Parts Individually		F-2000MWH F-2000MRH F-2000MRH-C	227632A03	1	1	-								
			227632A05			1	-							
			2A4672A01				1	-						
			2A4672A03						1	1				
		F-2000MRH3	227634A02	1	1	-								
			227634A03			1	-							
			2A4673A01				1	-						
			2A4673A02						1	1				
		F-2000MLH	227632A04		1	-								
			227632A06			1	-							
			2A4672A02				1	-						
			2A4672A04						1	1				
		1	Start Capacitor	F-2000MWH F-2000MRH F-2000MRH-C 189-227MFD, 330VAC	3A0076-12	1	1	1	1	1	1			
2	Run Capacitor	F-2000MWH F-2000MRH F-2000MRH-C 40MFD, 370VAC	439943-09 3A2005-13	1	-									
					1	1	1	1	1	1				
3	Start Relay (starter)	F-2000MWH F-2000MRH F-2000MRH-C	4A1107-09	1	1	1	1	1	1					
4	Magnetic Contactor	F-2000MWH F-2000MRH F-2000MRH3 F-2000MRH-C	4A0794-01	1	1	1	1	1	1					
5	Gear Motor Capacitor	65MFD, 250VAC	441021-01	1	1	1	1	1	1					
6	Water Control Relay and Spout Control Relay (V-1 and earlier)	24VAC	406132-06	2	2	2	2	1	1					
7	Circuit Protect Relay	F-2000MWH F-2000MRH F-2000MRH-C F-2000MLH 220/240VAC	418271-05	1	1	1	1	1	1					
8	Gear Motor Protect Relay	120VAC	418179-03	1	1	1	1	1	1					
9	Control Transformer		4A0557-01	1	1	1	1	1	1					
10	Control Board		437305-01	1	1	1	1	1	1					
10a	Control Board Support		4A0336-03	4	4	4	4	4	4					
11	Flush (Drain) Timer		4A0889-01	1	1	1	1	1	1					
12	Flush (Drain) Switch and Power Switch		4A0558-01	2	2	2	2	2	2					
13	Fuse Holder		4A5443-01	1	1	1	1	1	1					
14	Fuse	1A, 250VAC	4A0893-01	1	1	1	1	1	1					

Title: E. Control Box Assembly Model: F-2000MWH, F-2000MRH(3)(-C), F-2000MLH												
Index No.	Description	Material or Model Number	Part Number	Required Number								
				L-0	M-0 to Q-0 (E)	Q-0 (F) to T-0	T-1 to V-1	V-2 V-3	A-0 to B-1			
15	Protector		440972-01	1	1	-						
	Fuse Holder		4A0892-02			1	1	1	-			
			4A3449-02						1			
16	Fuse	7A, 125VAC	4A3804-01			1	1	1	1			
17	Lamp		4A1821-01	1	-							
			4A2672-01		1	1	1	-				
18	Control Box Cover		340314-01	1	1	1	1	1	1			

F. Chute Assembly

F-2000MWH, F-2000MRH(3)(-C), F-2000MLH

L-0 to B-1

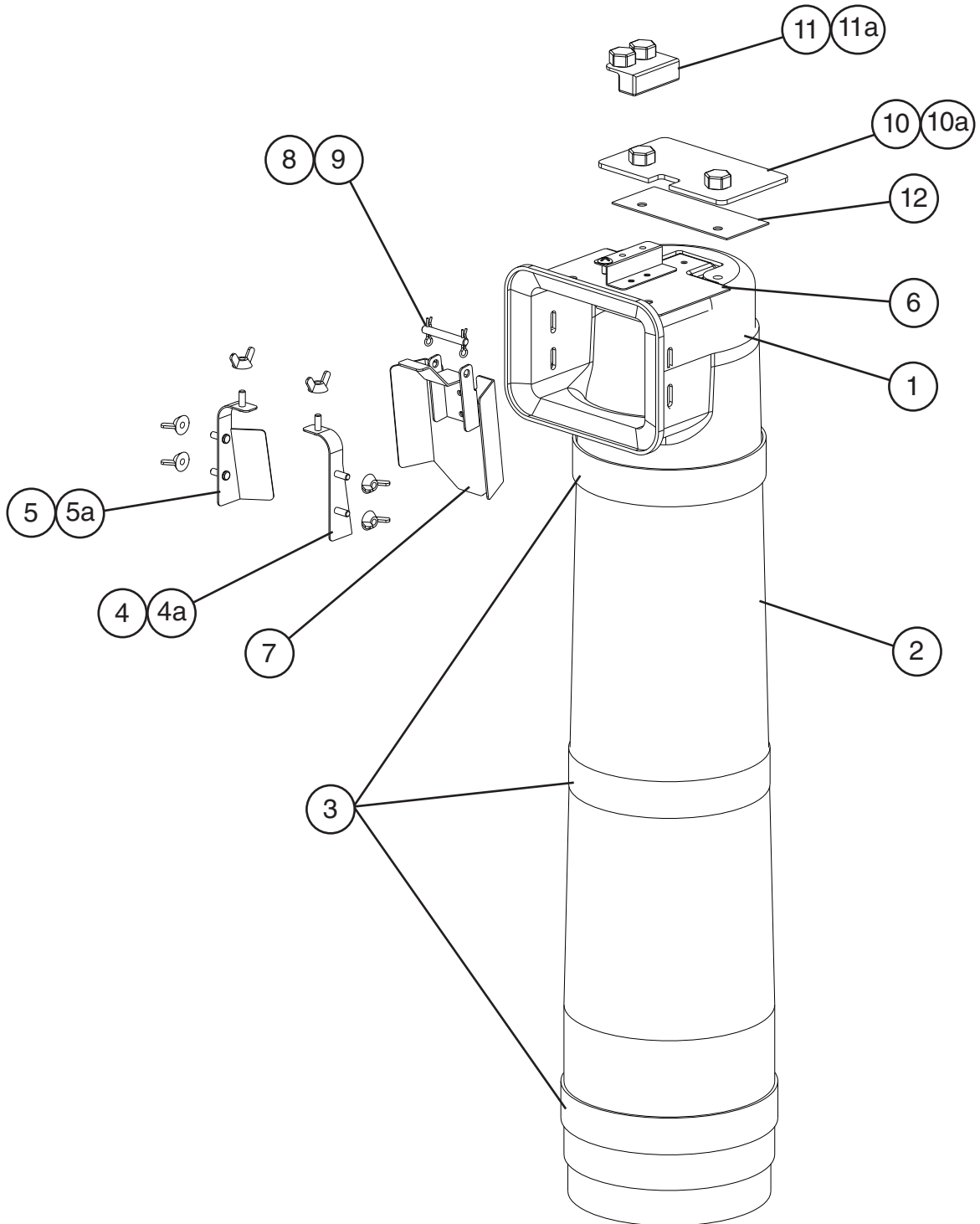

Title: F. Chute Assembly Model: F-2000MWH, F-2000MRH(3)(-C), F-2000MLH												
Index No.	Description	Material or Model Number	Part Number	Required Number								
				L-0 to T-0	T-1 to B-1							
Chute Assembly		HS-0116	2A1705A01	1	1							
Order Assembly Parts Individually												
1	Chute		216219-01	1	1							
2	Chute Insulation		216220-01	1	1							
3	Tie		436531G02	3	3							
4	Chute Baffle A		341012G01	1	1							
4a	Wing Nut		7E12-0400	3	3							
5	Chute Baffle B		341013G01	1	1							
5a	Wing Nut		7E12-0400	3	3							
6	Bin Control		3A1744G01	1	1							
7	Actuator		436848G02	1	1							
8	Shaft		436851-01	1	1							
9	Snap Pin		715S-0005	2	2							
10	Plate		4A2039-01	1	1							
10a	Thumbscrew		415949G10	2	2							
11	Proximity Switch		4A2033-01	1	1							
11a	Thumbscrew		415949G08	2	2							
12	Packing		441217-01	1	-							

G. Accessories, Labels, & Packaging
F-2000MWH, F-2000MRH(3)(-C), F-2000MLH
 L-0 to B-1

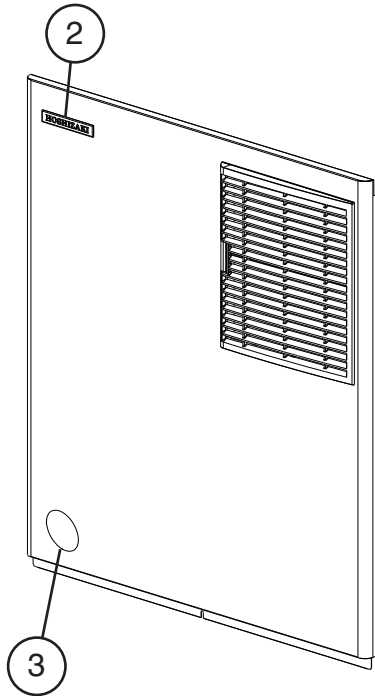

Title: G. Accessories, Labels, & Packaging Model: F-2000MWH, F-2000MRH(3)(-C), F-2000MLH					Required Number								
Index No.	Description	Material or Model Number	Part Number	L-0 to B-1									
1	Universal Brace		4A0363-01	2									
1a	Hex Head Bolt	5x12, SS	7B02-0512	2									
2	Hoshizaki Emblem Label		4A0560-01	1									
3	Penguin Label		4A0526-01	1									
	Packaging		1A0531A10										